

# FCC Test Report

## FCC ID: 2ANID-PFT-WA150

**Product:** N150Mbps Nano wireless adapter  
**Trade Mark:** N/A  
**Model Number:** PFT-WA150  
**Serial Model:** N/A  
**Report No.:** NTEK-2017NT08085541F2

**Prepared for**

Xworld Tech Pte. Ltd

1 Rochor Canal Road, #03-11, Sim Lim Square, Singapore – 188504.

**Prepared by**

Shenzhen NTEK Testing Technology Co., Ltd.  
1/F, Building E, Fenda Science Park, Sanwei Community,  
Xixiang Street Bao'an District, Shenzhen P.R. China  
Tel.: +86-755-6115 9388  
Fax.: +86-755-6115 6599  
Website: <http://www.ntek.org.cn>

### TEST RESULT CERTIFICATION

**Applicant's name** ..... : Xworld Tech Pte. Ltd

Address..... : 1 Rochor Canal Road, #03-11, Sim Lim Square, Singapore – 188504.

**Manufacturer's Name** ..... : Huizhou MTN WEIYE Technology Development Co.,Ltd

Address..... : No.2 Huitai Road, Huinan High-tech Industrial Park, Huihao Avenue, Huizhou City, Guangdong Province, China.

**Product description**

Product name..... : N150Mbps Nano wireless adapter

Model and/or type reference : PFT-WA150

FCC Part15B

**Standards** ..... : ANSI C63.4:2014

This device described above has been tested by NTEK, and the test results show that the equipment under test (EUT) is in compliance with Part 15 of FCC Rules. And it is applicable only to the tested sample identified in the report.

This report shall not be reproduced except in full, without the written approval of NTEK, this document may be altered or revised by NTEK, personnel only, and shall be noted in the revision of the document.

**Date of Test** .....

Date (s) of performance of tests..... : 08 Aug. 2017 ~ 24 Aug. 2017

Date of Issue ..... : 24 Aug. 2017

Test Result..... : **Pass**

Testing Engineer :

*Eileen Liu.*

(Eileen Liu)

Technical Manager :

*Jason chen*

(Jason Chen)

Authorized Signatory :

*Sam. chen*

(Sam Chen)

<b>Table of Contents</b>	<b>Page</b>
1 . TEST SUMMARY	4
1.1 TEST FACILITY	5
1.2 MEASUREMENT UNCERTAINTY	5
2 . GENERAL INFORMATION	6
2.1 GENERAL DESCRIPTION OF EUT	6
2.2 DESCRIPTION TEST PERIPHERAL AND EUT PERIPHERAL	9
2.3 MEASUREMENT INSTRUMENTS LIST	10
3 . EMC EMISSION TEST	11
3.1 CONDUCTED EMISSION MEASUREMENT	11
3.1.1 POWER LINE CONDUCTED EMISSION	11
3.1.2 TEST PROCEDURE	12
3.1.3 TEST SETUP	12
3.1.4 EUT OPERATING CONDITIONS	12
3.1.5 TEST RESULTS	13
3.2 RADIATED EMISSION MEASUREMENT	17
3.2.1 LIMITS OF RADIATED EMISSION MEASUREMENT	17
3.2.2 TEST PROCEDURE	17
3.2.3 TEST SETUP	18
3.2.4 TEST RESULTS	19
3.2.5 TEST RESULTS(1000~6000MHz)	21

## 1. TEST SUMMARY

Test procedures according to the technical standards:

EMC Emission				
Standard	Test Item	Limit	Judgment	Remark
FCC Part15B ANSI C63.4: 2014	Conducted Emission	Class B	PASS	
	Radiated Emission	Class B	PASS	

**NOTE:**

- (1) 'N/A' denotes test is not applicable in this Test Report
- (2) For client's request and manual description, the test will not be executed.

### 1.1 TEST FACILITY

Shenzhen NTEK Testing Technology Co., Ltd

Add. : 1/F, Building E, Fenda Science Park, Sanwei Community, Xixiang Street, Bao'an District, Shenzhen 518126 P.R. China.

FCC Registration Number:463705; IC Registration Number:9270A-1

CNAS Registration Number:L5516

### 1.2 MEASUREMENT UNCERTAINTY

The reported uncertainty of measurement  $y \pm U$ , where expanded uncertainty  $U$  is based on a standard uncertainty multiplied by a coverage factor of  $k=2$ , providing a level of confidence of approximately **95** %.

#### A. Conducted Measurement :

Test Site	Method	Measurement Frequency Range	U, (dB)	NOTE
NTEKC01	ANSI	150 KHz ~ 30MHz	3.2	

#### B. Radiated Measurement :

Test Site	Method	Measurement Frequency Range	U, (dB)	NOTE
NTEKA01	ANSI	30MHz ~ 1000MHz	4.7	
		1GHz ~12.4GHz	5.0	

## 2. GENERAL INFORMATION

### 2.1 GENERAL DESCRIPTION OF EUT

Equipment	N150Mbps Nano wireless adapter	
Trade Mark	N/A	
Model Name	PFT-WA150	
Serial Model	N/A	
Model Difference	N/A	
Product Description	The EUT is a N150Mbps Nano wireless adapter.	
	Connecting I/O port:	USB
	Operation Frequency:	WIFI:802.11b/g/n20:2412~2462MHz 802.11n40MHz: 2422-2452MHz
	Modulation Type:	IEEE 802.11b : DSSS (CCK, DQPSK, DBPSK) IEEE 802.11g/n (HT20/HT40) : OFDM (64QAM, 16QAM, QPSK, BPSK)
Power Source	DC 5V from Notebook	
Adapter	N/A	
Battery	N/A	
HW Version	MT-WN725N-V4.0	
SW Version	V1.0	

### 2.1.1 DESCRIPTION OF TEST MODES

To investigate the maximum EMI emission characteristics generated from EUT, the test system was pre-scanning tested based on the consideration of following EUT operation mode or test configuration mode which possibly have effect on EMI emission level. Each of these EUT operation mode(s) or test configuration mode(s) mentioned above was evaluated respectively.

Pretest Mode	Description
Mode 1	WIFI

For Conducted Test	
Final Test Mode	Description
Mode 1	WIFI

For Radiated Test	
Final Test Mode	Description
Mode 1	WIFI

Note: Final Test Mode: Through Pre-scan, find the mode 1 is the worst case. Only the worst case mode is recorded in the report.

### 2.1.2 DESCRIPTION OF TEST SETUP

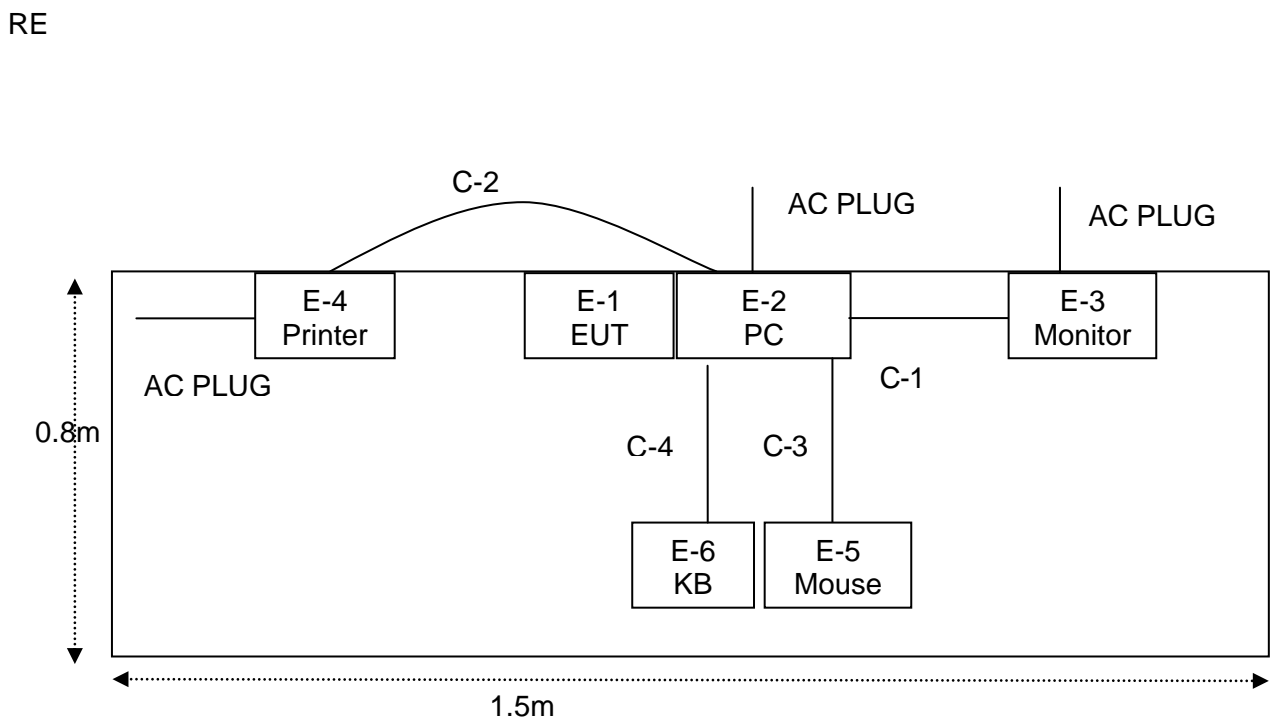
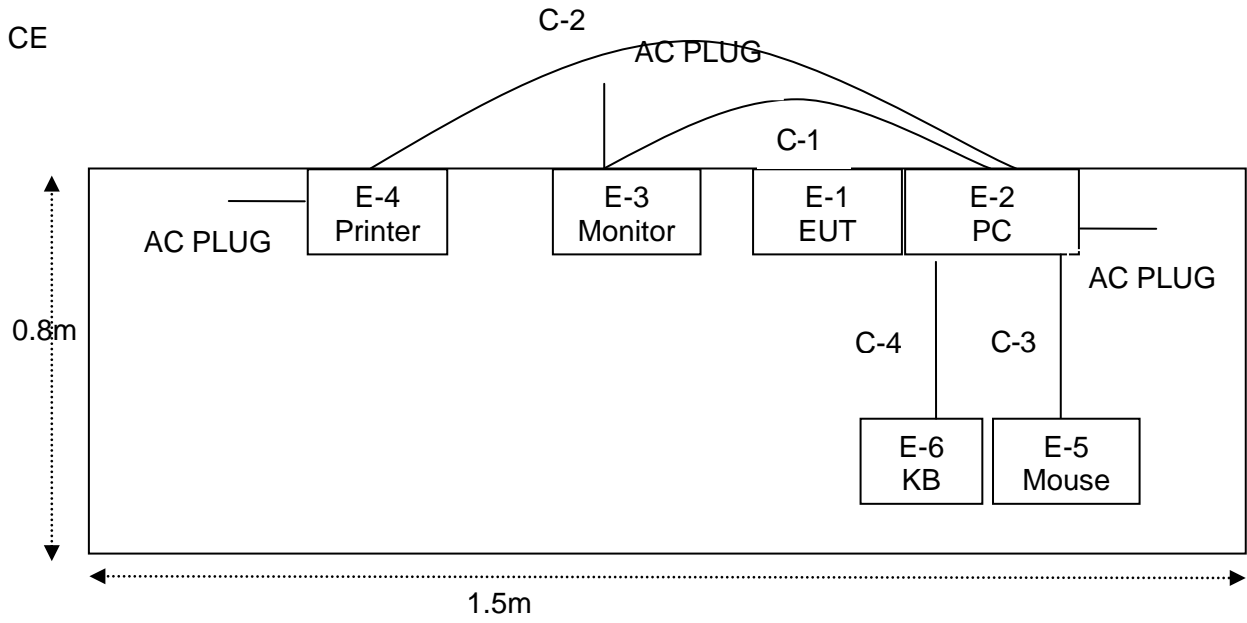



## 2.2 DESCRIPTION TEST PERIPHERAL AND EUT PERIPHERAL

The EUT has been tested as an independent unit together with other necessary accessories or support units. The following support units or accessories were used to form a representative test configuration during the tests.

Item	Equipment	Brand	Model/Type No.	Series No.	Note
E-1	N150Mbps Nano wireless adapter	N/A	PFT-WA150	N/A	EUT
E-2	Personal computer	DELL	FT4Y23X	34413561645	Peripherals
E-3	Monitor	SHARP	LCD-32MS46A	09426089241597	Peripherals
E-4	Printer	Canon	L11121E	LBP2900	Peripherals
E-5	Mouse	DELL	MS111-P	cn-011d3v-71581-11e-1th7	Peripherals
E-6	Keyboard	DELL	SK-8185	OY526KUS	Peripherals

Item	Cable Type	Shielded Type	Ferrite Core	Length	Note
C-1	HDMI Cable	NO	NO	1.0m	
C-2	USB Cable	NO	NO	1.2m	
C-3	Mouse Cable	NO	NO	1.2m	
C-4	Keyboard Cable	NO	NO	1.0m	

**Note:**

- (1) The support equipment was authorized by Declaration of Confirmation.
- (2) For detachable type I/O cable should be specified the length in cm in 『Length』 column.
- (3) “YES” means “shielded” “with core”; “NO” means “unshielded” “without core”.

## 2.3 MEASUREMENT INSTRUMENTS LIST

### Radiation Test equipment

Item	Kind of Equipment	Manufacturer	Type No.	Serial No.	Last calibration	Calibrated until	Calibration period
1	Spectrum Analyzer	Agilent	E4407B	MY45108040	2017.06.06	2018.06.05	1 year
2	Test Receiver	R&S	ESPI	101318	2017.06.06	2018.06.05	1 year
3	Bilog Antenna	TESEQ	CBL6111D	31216	2017.04.09	2018.04.08	1 year
4	50Ω Coaxial Switch	Anritsu	MP59B	6200264416	2017.06.06	2018.06.05	1 year
5	Spectrum Analyzer	ADVANTEST	R3132	150900201	2017.06.06	2018.06.05	1 year
6	Horn Antenna	EM	EM-AH-10180	2011071402	2017.04.09	2018.04.08	1 year
7	Horn Ant	Schwarzbeck	BBHA 9170	9170-181	2017.07.06	2018.07.05	1 year
8	Amplifier	EMC	EMC051835SE	980246	2017.08.09	2018.08.08	1 year
9	Loop Antenna	ARA	PLA-1030/B	1029	2017.06.06	2018.06.05	1 year
10	Power Meter	DARE	RPR3006W	15I00041SNO84	2017.08.09	2018.08.08	1 year
11	Power Sensor	R&S	URV5-Z4	0395.1619.05	2017.07.06	2018.07.05	1 year
12	Test Cable (30MHz-1GHz)	N/A	R-02	N/A	2017.04.21	2020.04.20	3 year
13	High Test Cable(1G-40GHz)	N/A	R-03	N/A	2017.04.21	2020.04.20	3 year
14	High Test Cable(1G-40GHz)	N/A	R-04	N/A	2017.04.21	2020.04.20	3 year

### Conduction Test equipment

Item	Kind of Equipment	Manufacturer	Type No.	Serial No.	Last calibration	Calibrated until	Calibration period
1	Test Receiver	R&S	ESCI	101160	2017.06.06	2018.06.05	1 year
2	LISN	R&S	ENV216	101313	2017.04.19	2018.04.18	1 year
3	LISN	SCHWARZBECK	NNLK 8129	8129245	2017.06.06	2018.06.05	1 year
4	50Ω Coaxial Switch	ANRITSU CORP	MP59B	6200983704	2017.06.06	2018.06.05	1 year
5	Test Cable (9KHz-30MHz)	N/A	C01	N/A	2017.04.21	2020.04.20	3 year
6	Test Cable (9KHz-30MHz)	N/A	C02	N/A	2017.04.21	2020.04.20	3 year
7	Test Cable (9KHz-30MHz)	N/A	C03	N/A	2017.04.21	2020.04.20	3 year

### 3. EMC EMISSION TEST

#### 3.1 CONDUCTED EMISSION MEASUREMENT

##### 3.1.1 POWER LINE CONDUCTED EMISSION (Frequency Range 150KHz-30MHz)

FREQUENCY (MHz)	Class A (dBuV)		Class B (dBuV)	
	Quasi-peak	Average	Quasi-peak	Average
0.15 -0.5	79.00	66.00	66 - 56 *	56 - 46 *
0.50 -5.0	73.00	60.00	56.00	46.00
5.0 -30.0	73.00	60.00	60.00	50.00

Note:

- (1) The tighter limit applies at the band edges.
- (2) The limit of " \* " marked band means the limitation decreases linearly with the logarithm of the frequency in the range.

The following table is the setting of the receiver

Receiver Parameters	Setting
Attenuation	10 dB
Start Frequency	0.15 MHz
Stop Frequency	30 MHz
IF Bandwidth	9 kHz

### 3.1.2 TEST PROCEDURE

- a. The EUT was placed 0.8 meters from the horizontal ground plane with EUT being connected to the power mains through a line impedance stabilization network (LISN). All other support equipments powered from additional LISN(s). The LISN provide 50 Ohm/ 50uH of coupling impedance for the measuring instrument.
- b. Interconnecting cables that hang closer than 40 cm to the ground plane shall be folded back and forth in the center forming a bundle 30 to 40 cm long.
- c. I/O cables that are not connected to a peripheral shall be bundled in the center. The end of the cable may be terminated, if required, using the correct terminating impedance. The overall length shall not exceed 1 m.
- d. LISN at least 80 cm from nearest part of EUT chassis.
- e. For the actual test configuration, please refer to the related Item –EUT Test Photos.

### 3.1.3 TEST SETUP

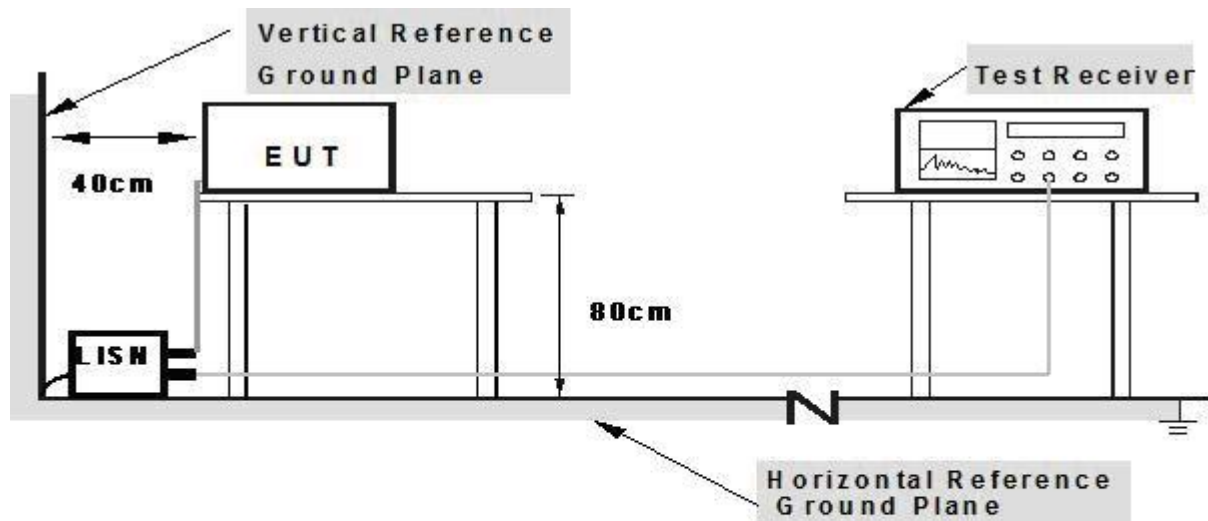

**Note: 1. Support units were connected to second LISN.**

**2. Both of LISNs (AMN) are 80 cm from EUT and at least 80 cm from other units and other metal planes**

### 3.1.4 EUT OPERATING CONDITIONS

The EUT tested system was configured as the statements of 2.3 Unless otherwise a special operating condition is specified in the follows during the testing.

### 3.1.5 TEST RESULTS

EUT:	N150Mbps Nano wireless adapter	Model Name. :	PFT-WA150
Temperature:	26 °C	Relative Humidity:	54%
Pressure:	1010hPa	Test Date:	2017-08-08
Test Mode:	Mode 1	Phase :	L
Test Voltage:	DC 5V from Notebook AC120V/60Hz		

Frequency (MHz)	Reading Level (dBμV)	Correct Factor (dB)	Measure-ment (dBμV)	Limits (dBμV)	Margin (dB)	Remark
0.1740	40.50	9.82	50.32	64.76	-14.44	QP
0.1860	31.39	9.82	41.21	54.21	-13.00	AVG
2.0980	12.49	9.86	22.35	46.00	-23.65	QP
2.4260	26.93	9.93	36.86	56.00	-19.14	AVG
7.9620	23.80	9.97	33.77	50.00	-16.23	QP
8.1059	36.27	9.97	46.24	60.00	-13.76	AVG

Remark:

1. All readings are Quasi-Peak and Average values.
2. Factor = Insertion Loss + Cable Loss.

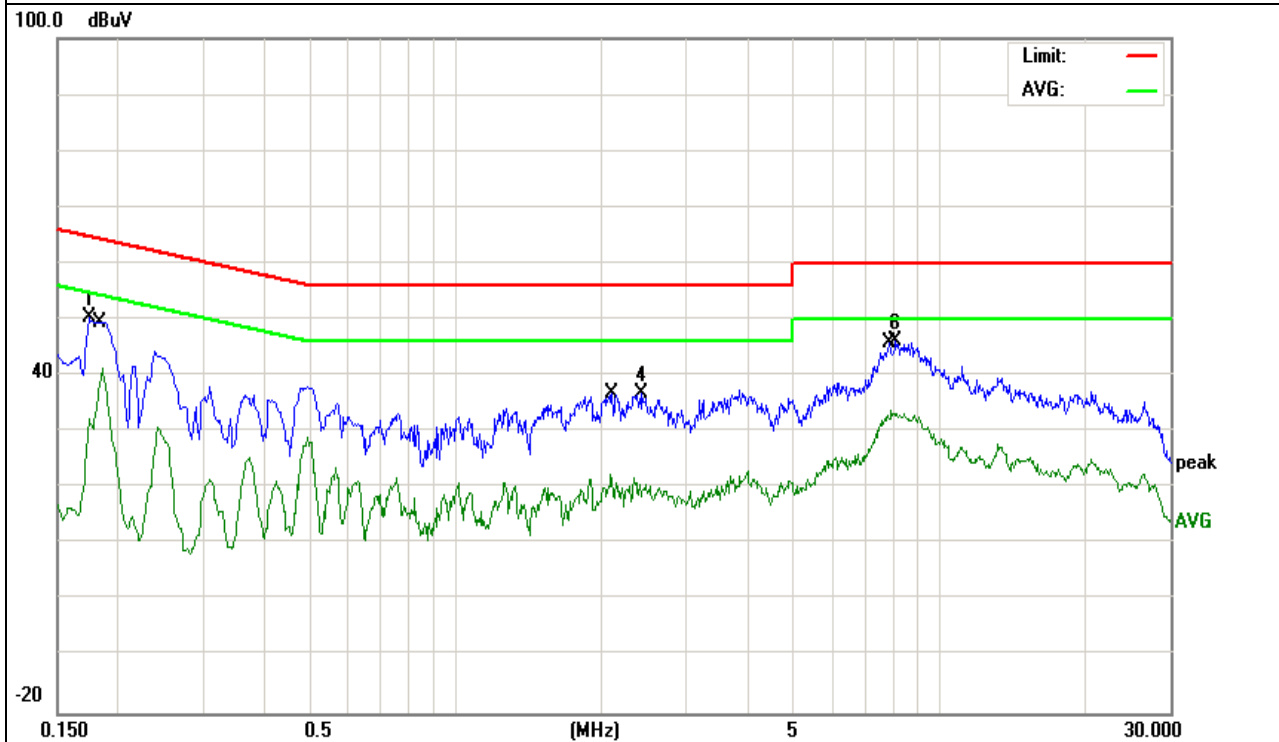

EUT:	N150Mbps Nano wireless adapter	Model Name. :	PFT-WA150
Temperature:	26 °C	Relative Humidity:	54%
Pressure:	1010hPa	Test Date:	2017-08-08
Test Mode:	Mode 1	Phase :	N
Test Voltage:	DC 5V from Notebook AC120V/60Hz		

Frequency (MHz)	Reading Level (dBμV)	Correct Factor (dB)	Measure-ment (dBμV)	Limits (dBμV)	Margin (dB)	Remark
0.1780	39.53	9.92	49.45	64.57	-15.12	QP
0.1860	27.33	9.92	37.25	54.21	-16.96	AVG
7.5340	25.02	10.07	35.09	50.00	-14.91	QP
8.5420	37.52	10.07	47.59	60.00	-12.41	AVG

Remark:

1. All readings are Quasi-Peak and Average values.
2. Factor = Insertion Loss + Cable Loss.

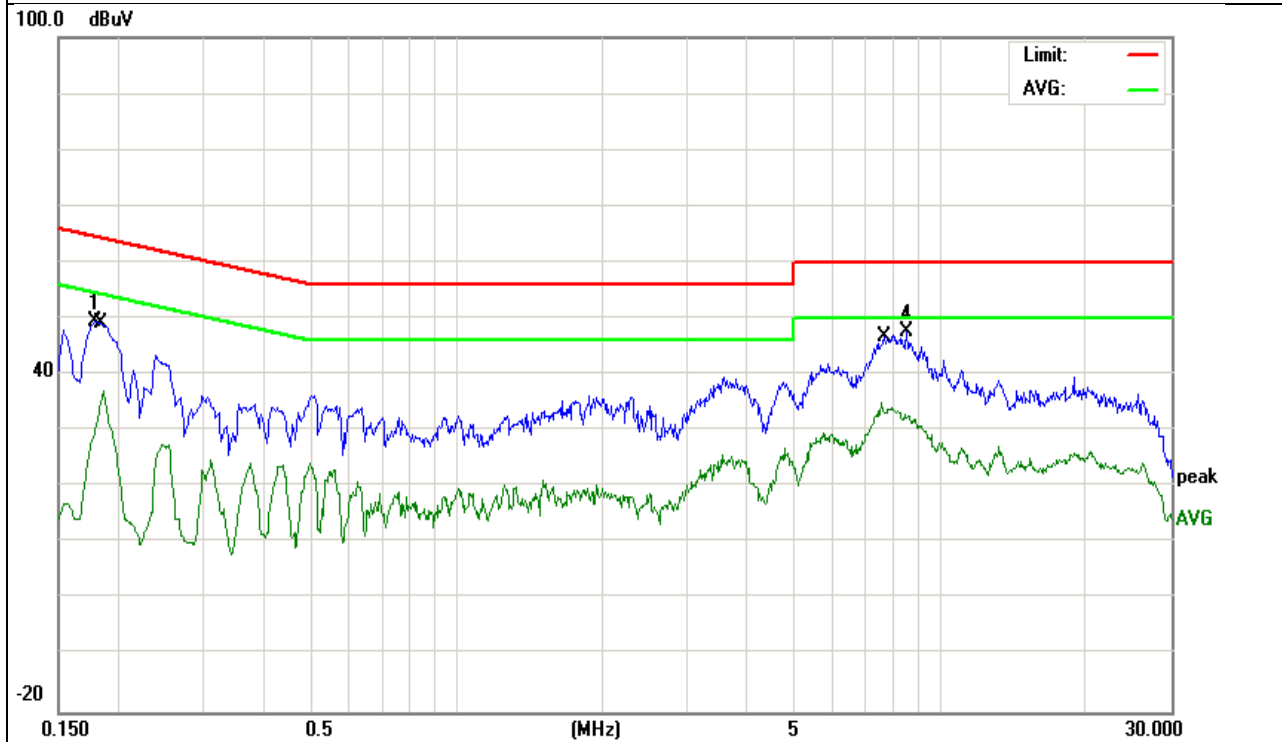

EUT:	N150Mbps Nano wireless adapter	Model Name. :	PFT-WA150
Temperature:	26 °C	Relative Humidity:	54%
Pressure:	1010hPa	Test Date:	2017-08-08
Test Mode:	Mode 1	Phase :	L
Test Voltage:	DC 5V from Notebook AC240V/60Hz		

Frequency (MHz)	Reading Level (dBμV)	Correct Factor (dB)	Measure-ment (dBμV)	Limits (dBμV)	Margin (dB)	Remark
0.1940	39.10	9.82	48.92	63.86	-14.94	QP
0.1940	27.99	9.82	37.81	53.86	-16.05	AVG
8.6340	27.07	9.97	37.04	50.00	-12.96	QP
8.8660	38.03	9.97	48.00	60.00	-12.00	AVG

Remark:

1. All readings are Quasi-Peak and Average values.
2. Factor = Insertion Loss + Cable Loss.

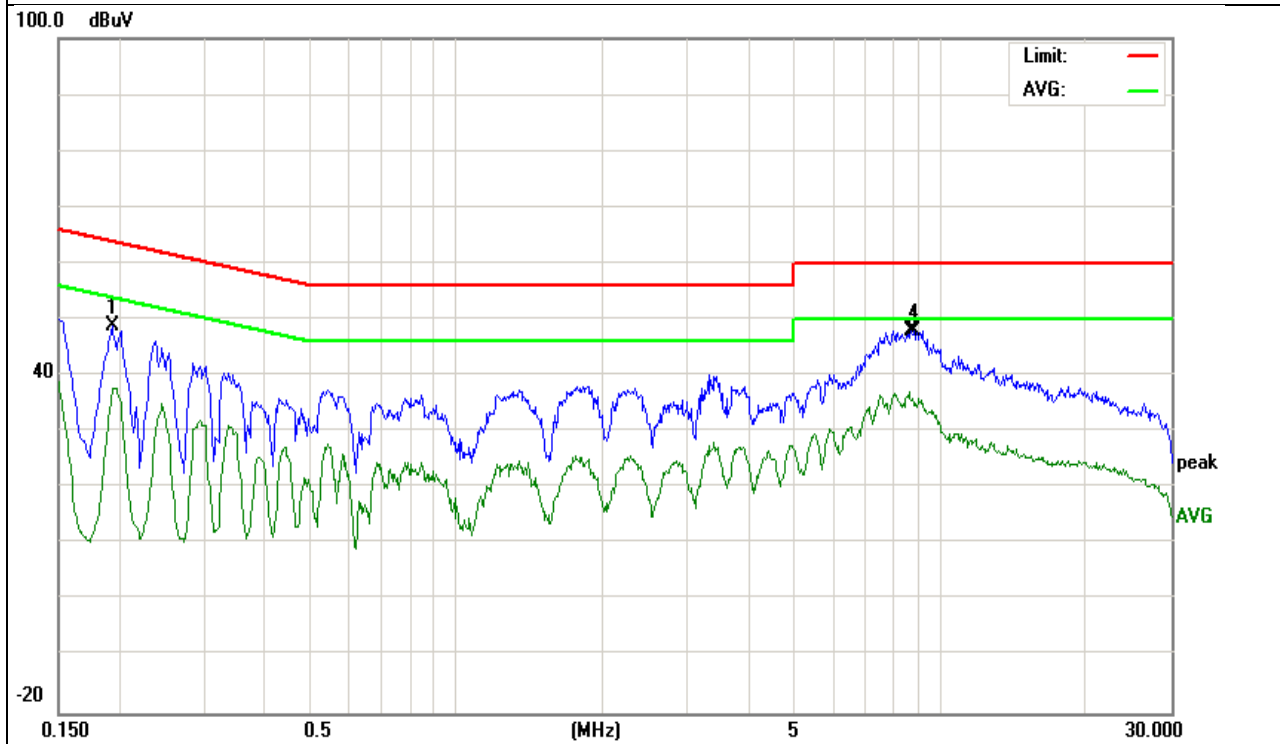

EUT:	N150Mbps Nano wireless adapter	Model Name. :	PFT-WA150
Temperature:	26 °C	Relative Humidity:	54%
Pressure:	1010hPa	Test Date:	2017-08-08
Test Mode:	Mode 1	Phase :	N
Test Voltage:	DC 5V from Notebook AC240V/60Hz		

Frequency (MHz)	Reading Level (dBμV)	Correct Factor (dB)	Measure-ment (dBμV)	Limits (dBμV)	Margin (dB)	Remark
0.1900	38.55	9.92	48.47	64.03	-15.56	QP
0.1980	27.74	9.92	37.66	53.69	-16.03	AVG
7.3820	27.43	10.07	37.50	50.00	-12.50	QP
7.7260	38.61	10.07	48.68	60.00	-11.32	AVG

Remark:

1. All readings are Quasi-Peak and Average values.
2. Factor = Insertion Loss + Cable Loss.

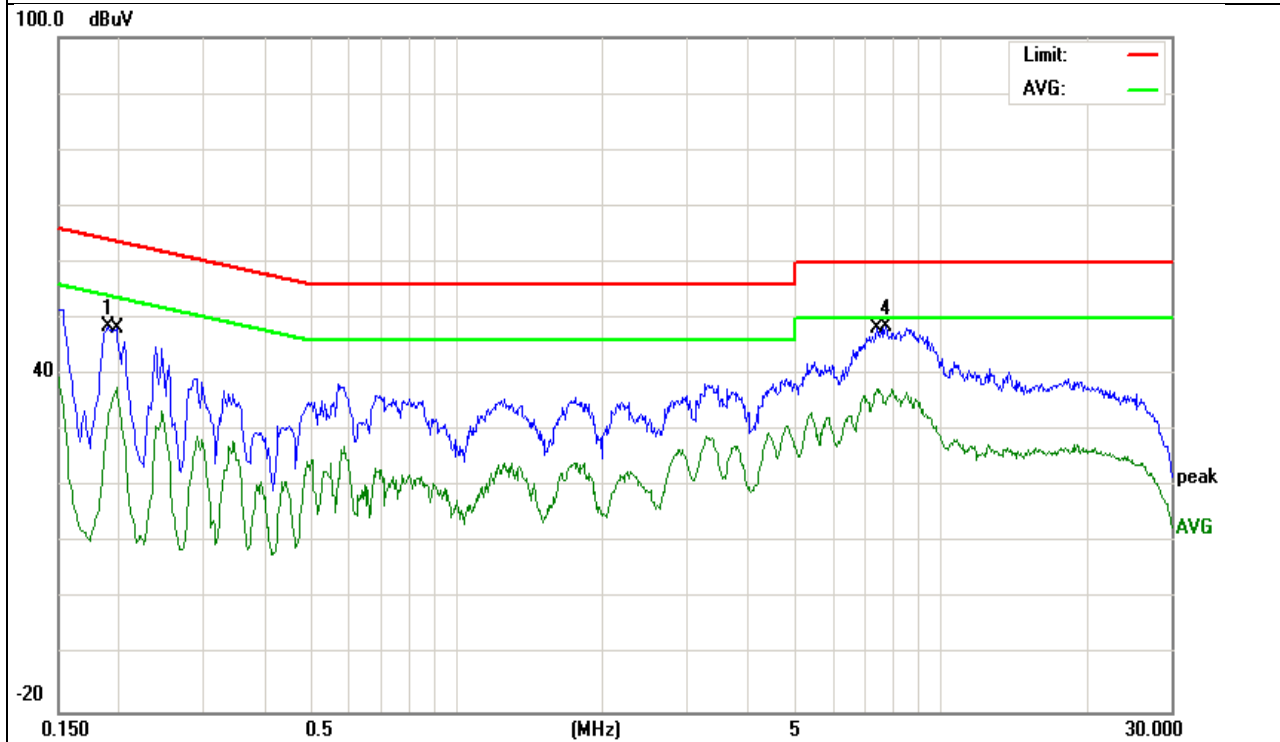



### 3.2 RADIATED EMISSION MEASUREMENT

#### 3.2.1 LIMITS OF RADIATED EMISSION MEASUREMENT

FREQUENCY (MHz)	Class A (at 10m)	Class B (at 3m)
	dBuV/m	dBuV/m
30 ~ 88	39.0	40.0
88 ~ 216	43.5	43.5
216 ~ 960	46.5	46.0
Above 960	49.5	54.0

Notes:

- (1) The limit for radiated test was performed according to as following:  
FCC PART 15B /ICES-003.
- (2) The tighter limit applies at the band edges.
- (3) Emission level (dBuV/m)=20log Emission level (uV/m).

#### 3.2.2 TEST PROCEDURE

##### Test Arrangement for Radiated Emissions up to 1 GHz

- a. The EUT was placed on the top of a rotating table 0.8 meters above the ground at an accredited test facility. The table was rotated 360 degrees to determine the position of the highest radiation.
- b. The EUT was set 3 meters away from the interference-receiving antenna, which was mounted on the top of a variable-height antenna tower.
- c. The antenna is a broadband antenna, and its height is varied from one meter to four meters above the ground to determine the maximum value of the field strength. Both horizontal and vertical polarizations of the antenna are set to make the measurement.
- d. For each suspected emission, the EUT was arranged to its worst case and then the antenna was tuned to heights from 1 meter to 4 meters and the rotatable table was turned from 0 degrees to 360 degrees to find the maximum reading.

Note: The resolution bandwidth and video bandwidth of test receiver/spectrum analyzer is 120kHz for quasi-peak detection (QP) at frequency below 1GHz.

##### Test Arrangement for Radiated Emissions above 1 GHz.

- a. The EUT was placed on the top of a rotating table 0.8 meters above the ground at an accredited chamber room. The table was rotated 360 degrees to determine the position of the highest radiation.
- b. The EUT was set 3 meters away from the interference-receiving antenna, which was mounted on the top of a variable-height antenna tower.
- c. The height of antenna can be varied from one meter to four meters, the height of adjustment depends on the EUT height and the antenna 3dB beamwidth both, to detect the maximum value of the field strength.Both horizontal and vertical polarizations of the antenna are set to make the measurement.
- d. For each suspected emission, the EUT was arranged to its worst case and then the antenna was tuned to heights and the rotatable table was turned from 0 degrees to 360 degrees to find the maximum reading.

Note: For the hand-held device, the EUT should be measured for all 3 axes and only the worst case is recorded in the report  
 During the radiated emission test, the Spectrum Analyzer was set with the following configurations:

Frequency Band (MHz)	Function	Resolution bandwidth	Video Bandwidth
30 to 1000	QP	120 kHz	300 kHz
Above 1000	Peak	1 MHz	1 MHz
	Avg	1 MHz	10 Hz

### 3.2.3 TEST SETUP

For Radiated Emission 30~1000MHz

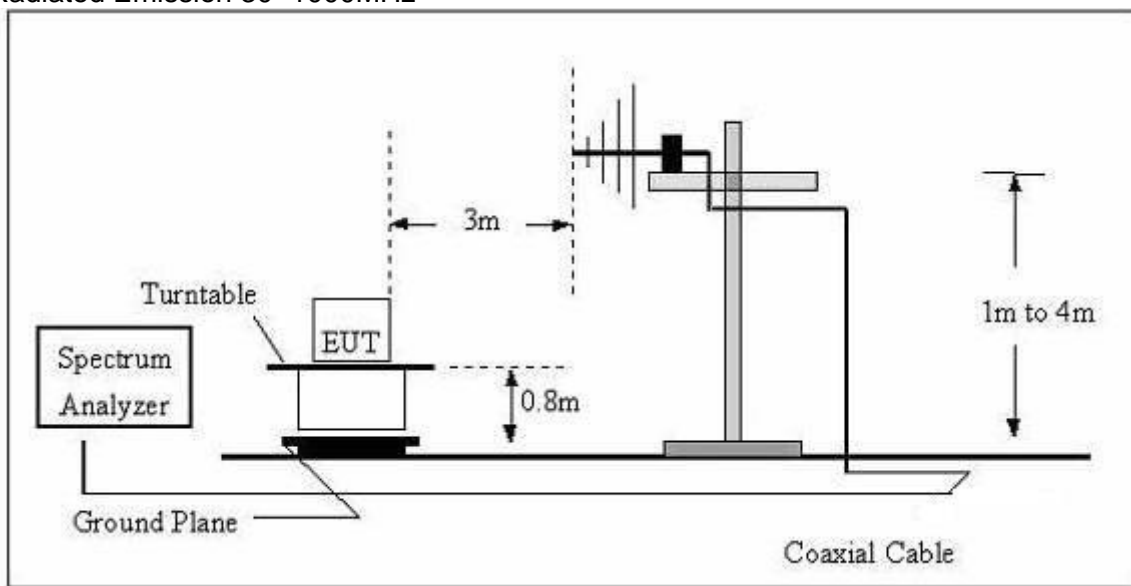

(B) Radiated Emission Test Set-Up Frequency Above 1GHz

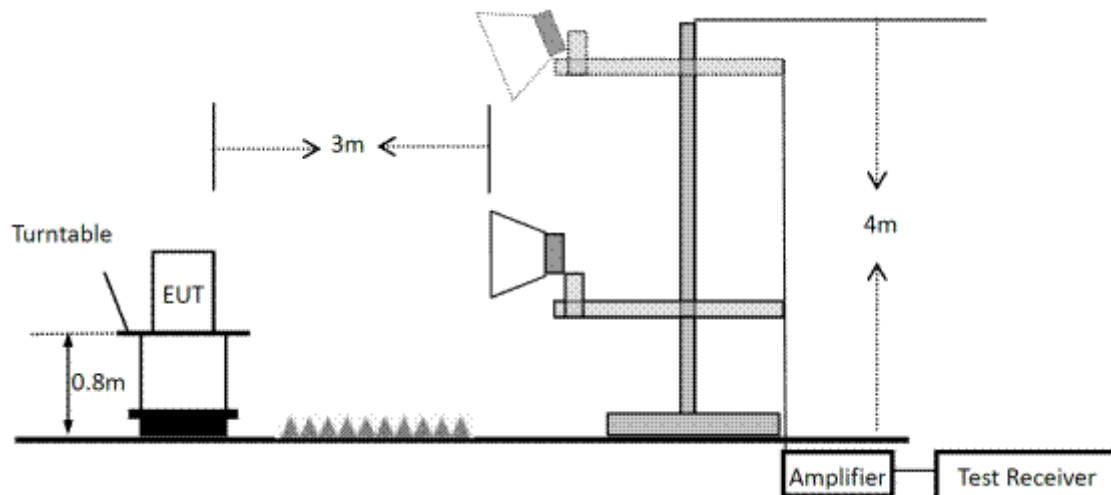

## 3.2.4 TEST RESULTS

## TEST RESULTS (30~1000 MHz)

EUT:	N150Mbps Nano wireless adapter	Model Name:	PFT-WA150
Temperature:	24 °C	Relative Humidity:	54%
Pressure:	1010 hPa	Test Date :	2017-08-08
Test Mode :	Mode 1	Polarization :	Horizontal
Test Power :	DC 5V from Notebook AC120V/60Hz		

Polar (H/V)	Frequency	Meter Reading	Factor	Emission Level	Limits	Margin	Remark
	(MHz)	(dBuV)	(dB)	(dBuV/m)	(dBuV/m)	(dB)	
H	31.1798	6.10	20.70	26.80	40.00	-13.20	QP
H	68.6310	10.84	10.06	20.90	40.00	-19.10	QP
H	192.4184	13.49	13.21	26.70	43.50	-16.80	QP
H	570.6100	11.48	18.67	30.15	46.00	-15.85	QP
H	1000.0000	5.87	28.25	34.12	54.00	-19.88	QP

Remark:

Factor = Antenna Factor + Cable Loss - Amplifier.

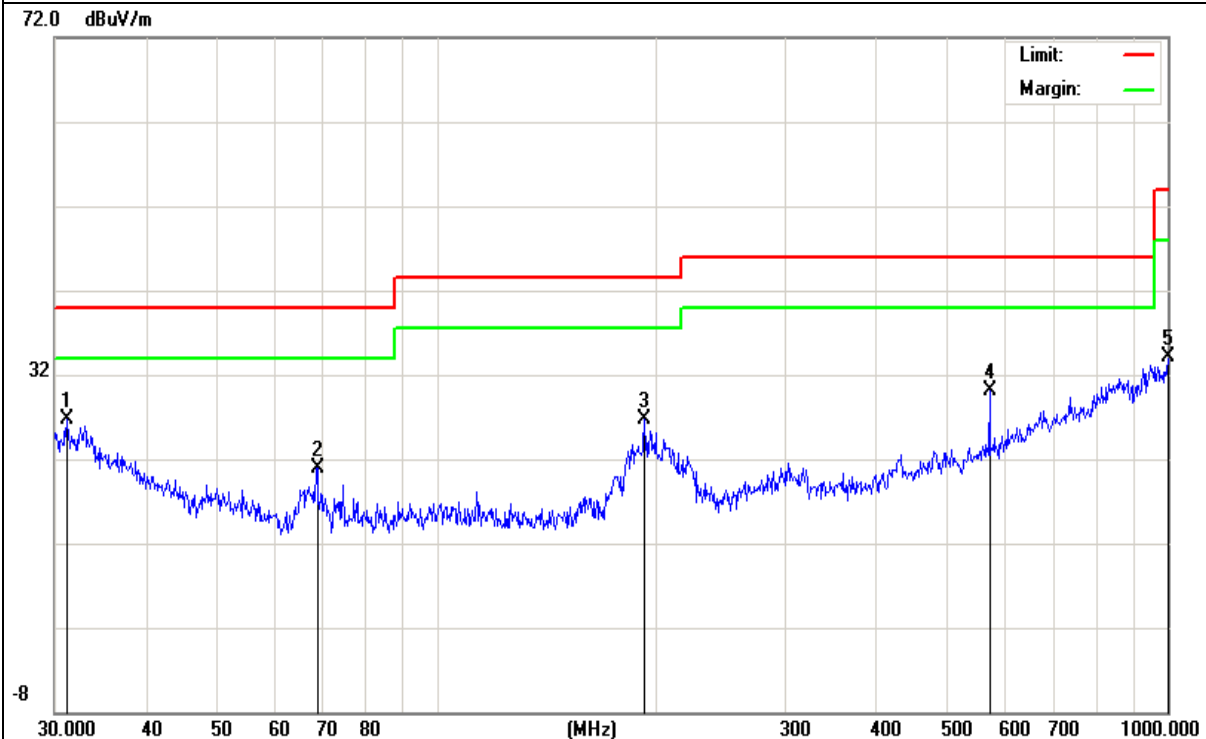

EUT:	N150Mbps Nano wireless adapter	Model Name :	PFT-WA150
Temperature:	24 °C	Relative Humidity:	54%
Pressure:	1010 hPa	Test Date :	2017-08-08
Test Mode :	Mode 1	Polarization :	Vertical
Test Power :	DC 5V from Notebook AC120V/60Hz		

Polar (H/V)	Frequency	Meter Reading	Factor	Emission Level	Limits	Margin	Remark
	(MHz)	(dBuV)	(dB)	(dBuV/m)	(dBuV/m)	(dB)	
V	33.4448	6.96	19.64	26.60	40.00	-13.40	QP
V	137.4201	9.07	11.53	20.60	43.50	-22.90	QP
V	210.0482	14.13	13.27	27.40	43.50	-16.10	QP
V	517.2480	9.95	17.15	27.10	46.00	-18.90	QP
V	568.6127	9.83	18.67	28.50	46.00	-17.50	QP
V	663.4728	11.06	20.94	32.00	46.00	-14.00	QP

Remark:

Factor = Antenna Factor + Cable Loss - Amplifier.

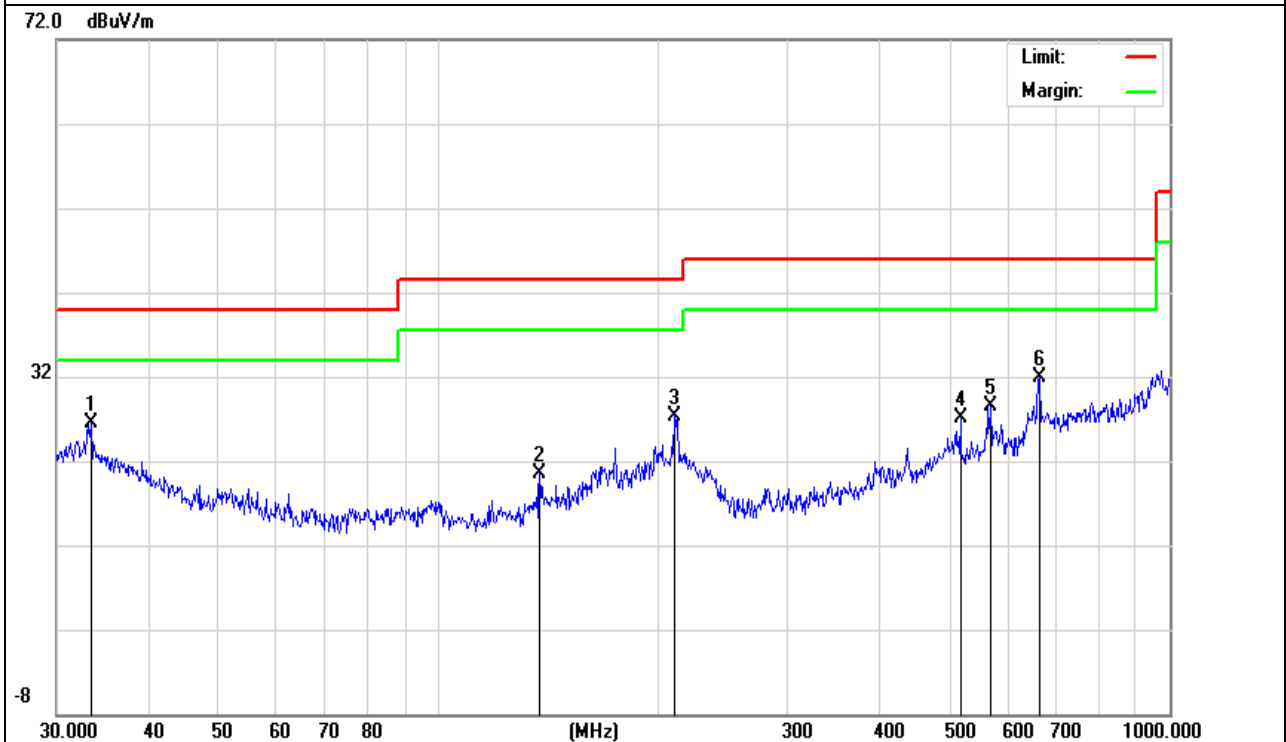

## 3.2.5 TEST RESULTS(1000~6000MHz)

EUT:	N150Mbps Nano wireless adapter	Model Name :	PFT-WA150
Temperature:	24 °C	Relative Humidity:	54%
Pressure:	1010 hPa	Test Date :	2017-08-08
Test Mode :	Mode 1		
Test Power :	DC 5V from Notebook AC120V/60Hz		

All the modulation modes have been tested, and the worst result was report as below:

Polar (H/V)	Frequency	Reading	Correct	Result	Limit	Over Limit	Remark
	(MHz)	(dBuV/m)	dB/m	(dBuV/m)	(dBuV/m)	(dB)	
V	1559.4860	64.13	-8.88	55.25	74.00	-18.75	Pk
V	1559.4860	44.22	-8.88	35.34	54.00	-18.66	AV
V	1875.5610	54.76	-8.02	46.74	74.00	-27.26	Pk
V	1875.5610	36.04	-8.02	28.02	54.00	-25.98	AV
V	3119.7950	49.08	-4.69	44.39	74.00	-29.61	Pk
V	3119.7950	35.01	-4.69	30.32	54.00	-23.68	AV
H	1559.4860	65.72	-8.88	56.84	74.00	-17.16	Pk
H	1559.4860	42.04	-8.88	33.16	54.00	-20.84	AV
H	1872.2030	57.68	-8.04	49.64	74.00	-24.36	Pk
H	1872.2030	38.26	-8.04	30.22	54.00	-23.78	AV
H	3125.3900	51.93	-4.66	47.27	74.00	-26.73	Pk
H	3125.3900	36.26	-4.66	31.60	54.00	-22.40	AV

Remark:

Absolute Level= ReadingLevel+ Factor, Margin= Absolute Level - Limit

Note: Only the worst results data points are reported in the report.

END OF REPORT