

## Portable Electro-Stimulation Therapy Device

## USER MANUAL LGT-233

### MStim Drop

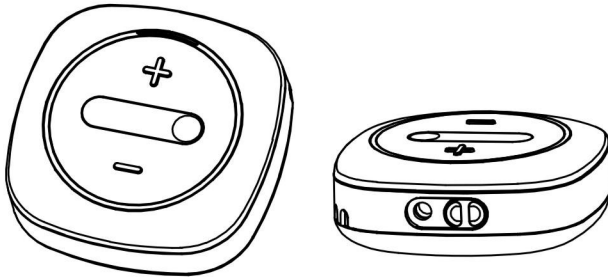

Please read this user manual  
before starting to use the device.

## TABLE OF CONTENTS

---

<i>Foreword</i> .....	2
<i>Safety Instructions</i> .....	4
<i>EMC Guidance</i> .....	15
<i>Clinical Instructions</i> .....	23
<i>Working Principle</i> .....	25
<i>Inspection of the Goods</i> .....	26
<i>Overview of the Unit</i> .....	28
<i>MStim Drop Application</i> .....	33
<i>Operation Guidance</i> .....	55
<i>Care and Maintenance</i> .....	60
<i>Troubleshooting</i> .....	64
<i>Technical Specifications</i> .....	67
<i>Assistance</i> .....	70
<i>Warranty</i> .....	71

---

## **Foreword**

---

*Thank you for purchasing the **MStim Drop LGT-233** from our company.*

*This manual has been written for the owners and operators of the **MStim Drop LGT-233**. It contains general information on the instructions for safety, intended use, working principle, operation, maintenance, troubleshooting, and warranty. In order to maximize the use, efficiency, and working life of your unit, please read this manual thoroughly and become familiar with the controls, as well as the accessories, before operating the unit.*

*Specifications put fifth in this manual were in effect at the time of publication. However, owing to policy of continual improvement by Guangzhou Longest Science & Technology Co., Ltd., any changes to these specifications may be made at any time without obligation on the part of Guangzhou Longest Science & Technology Co., Ltd.*

*Before administering any treatment to a patient, the user of this equipment should read, understand, and follow the information contained in this manual for each mode of treatment available, as well as the indications, contraindications, warnings, and precautions.*

## **Product Description**

---

*The **MStim Drop LGT-233** is a wearable foot drop device, which is mainly consists of stimulator unit, MStim Drop APP, electrode lead hose, electrodes and leg bandage. It can control the timing and duration of the stimulation by tracing the angle during walking, using FES (Functional Electrical Stimulation) to treat and improve the patient's foot drop and help to improve walking ability.*

*It has three modes: Training mode, Walk mode and Evaluation mode. Training mode is suitable for muscle training when the patient is seated or lying down (patient lacking active training), which can promote muscle recover, prevent muscle atrophy, improve joint range of motion, and increase local blood flow. Walk mode is walking with the electrical stimulation. It is suitable for patients to walk to restore the correct gait, while walking stimulation, to provide the correct mode of motion, to rebuild the motor function of the brain to restore limb walking function. Evaluation mode is walking without the electric stimulation. It is suitable for recording the calf, thigh bending angle when patient walks. The data recorded can compare with walking mode.*





# Safety Instructions







---

## Symbols







---

### 1. Symbols on the medical device

<i>Symbols</i>	<i>Explanation</i>
	<i>Manufacturer</i>
	<i>Date of manufacture</i>
	<i>EU Representative</i>
	<i>This product complies with European Directive 93/42 EEC for medical products. (0598 is the notified body number)</i>

	<p><i>Correct Disposal of This Product (Waste Electrical &amp; Electronic Equipment)</i>  <i>Statement: Contact the local authorities to determine the proper method of disposal of potentially bio-hazardous parts and accessories.</i></p>
	<p><i>Type BF applied part (i.e. electrode) complying with IEC60601-1.</i></p>
<p><b>IP22</b></p>	<p><i>Protected against solid foreign objects of 12.5 mm (0.5 in) diameter and greater;          Protected against vertically falling water drops when enclosure tilted up to 15°.</i></p>
	<p><i>This device emits non-ionizing radiation.</i></p>
	<p><i>This symbol indicates that this device is a Class II equipment according to IEC 60601-1 (when charging)</i></p>
	<p><i>Refer to instruction manual/ booklet</i></p>
	<p><i>Caution output. It is placed near all electrode connections.</i></p>

## 2. Symbols on the package

Symbols	Explanation
	<p><i>This side up</i>  <i>The transportation package must be vertical and straight up during transportation.</i></p>
	<p><i>Fragile, handle with care</i>  <i>The product inside the packaging could be easily damaged if dropped or handled without care and attention.</i></p>
	<p><i>Keep away from rain</i>  <i>The product package should keep out of the rain and not to store it in damp conditions.</i></p>
	<p><i>Temperature limitation</i>  <i>The product package should be stored at a temperature between -20 and 55 degrees (centigrade).</i></p>
	<p><i>Upper limit of humidity</i>  <i>The product package should be stored at a humidity less than 93%.</i></p>
	<p><i>Atmospheric pressure limitation</i>  <i>The product package should be stored at an atmospheric pressure between 86kPa and 106kPa.</i></p>

## Precautionary Definitions

---

The precautionary instructions found in this section and throughout this manual are indicated by specific symbols. Understand these symbols and their definitions before operating this equipment. The definition of these symbols is as follows:



Text with a “CAUTION” indicator will explain possible safety infractions that could have the potential to cause minor to moderate injury or damage to equipment.



Text with a “WARNING” indicator will explain possible safety infractions that will potentially cause serious injury and equipment damage.



Text with a “DANGER” indicator will explain possible safety infractions that are imminently hazardous situations that would result in death or serious injury.





**Refer to Instruction Manual/Booklet**

**NOTE:** Throughout this manual, “NOTE” may be found. These Notes are helpful information to aid in the particular area or function being described.



Type BF applied part (i.e. electrode) complying with IEC60601-1.

## Warnings and cautions

---

Please carefully read and understand the following warnings and cautions to ensure the safe and correct use of the **MStim Drop LGT-233** and to prevent injury.



- Read, understand, and practice the precautionary operating instructions. Know the limitations and hazards associated with using the **MStim Drop LGT-233**. Observe the precautionary and operational decals placed on the unit.
- Before using **MStim Drop LGT-233** make sure you have read and understood all information provided in this manual. Familiarity with the information included in this manual is an essential requirement to ensure efficient and optimal use of the system, to avoid dangers to persons and to the equipment, and to obtain good treatment results.
- Improper installation, operation, or maintenance of the **MStim Drop LGT-233** may result in malfunctions of this unit or other devices.
- In case of display failure or other obvious defects, switch the unit off immediately, and notify a certified service technician.
- Adjustments or replacement of components may result in the equipment failing to meet the

*requirements for interference suppression.*

- *This **MStim Drop LGT-233** should be kept out of the reach of children.*
- *Do not use this unit near the heart or chest, above the neck, on the head, around the mouth or on diseased skin.*
- *The placement of the electrodes can be referenced to the reference schematic provided by APP, note that the following parts cannot be placed:*
  - a) *carotid sinus (current may affect blood pressure and cardiac contraction, causing arrhythmia);*
  - b) *infection site (which may aggravate the infection);*
  - c) *pregnant women's abdomen and lumbosacral (may cause uterine contractions);*
  - d) *surgical site (muscle contraction may cause wound dehiscence);*
  - e) *malignant neoplasms;*
  - f) *sensory defects or parts that are allergic to the electrodes;*
  - g) *eye.*
- *Do not use this unit for purposes other than treatment indicated in this manual;*
- *Do not use the **MStim Drop LGT-233** with high frequency surgical equipments on the patient. It will cause unstable output when the unit is close to the high frequency equipments (in the same room and without shield).*
- *Do not use electrodes with an active area of less than 25 cm<sup>2</sup> due to the risk of associated burning.*

*Proceed systematically with caution when the density of the current is over 2 mA /cm<sup>2</sup>.*

- *Do not modify this device without authorization of the manufacturer.*
- *Only use this device with the charger, cables, electrodes and accessories recommended by the manufacturer.*
- *The **MStim Drop LGT-233** contains built-in batteries that cannot be removed by the user. Do not replace it by yourself to avoid damage the batteries or device. If necessary, please contact the company or the company authorized maintenance personnel to replace.*
- *Do not use this device simultaneously with other therapeutic device (such as microwave), to avoid mis-operation.*
- *Please dispose of the equipment and other accessories according to local regulations. Do not treat them as household waste. Do not put the device in fire or water. If the batteries are not properly disposed, it may cause a battery explosion.*
- *Do not use when the unit is charging.*



- *Always check the device and the electrodes for damage before use.*
- *If the unit is not functioning properly or you feel discomfort, immediately stop using the unit. If you feel any trouble with your body or skin, consult the doctor and follow his/her instructions.*

- *The self-adhesive electrode limited to the same person to use, do not use in another patients to prevent infection.*
- *If the electrode loses viscosity, please replace the electrode in order to maintain good electrical properties.*
- *Do not use this unit in places with high humidity such as the bathrooms or while taking a bath or shower.*
- *Do not use this unit while sleeping. The main unit may develop trouble, or the pad may move to an unexpected region and cause ill health.*
- *Clean the device using a dry soft cloth. Do not use cleaning solvents or other chemical substances in order to avoid any damage.*
- *Make sure that you end the treatment by switching off the units or by setting the intensity to 0mA before you remove the units or the electrodes. If you do not end the treatment, you may experience an unpleasant sensation in your fingers. This sensation is not harmful, but can be unpleasant.*
- *Handle the unit with care. Do not drop, knock, or shake the unit. Rough handling can damage internal circuit boards.*
- *Do not apply stimulation while driving, operating machines or while performing any other activity in which electrical stimulation can put you at risk of injury.*

- *Always disconnect the power charger from the mains after use.*

## **FCC**

---

*Changes or modifications not expressly approved by the party responsible for compliance could void the user's authority to operate the equipment.*

*This equipment has been tested and found to comply with the limits for a Class B digital device, pursuant to Part 15 of the FCC Rules. These limits are designed to provide reasonable protection against harmful interference in a residential installation. This equipment generates, uses and can radiate radio frequency energy and, if not installed and used in accordance with the instructions, may cause harmful interference to radio communications. However, there is no guarantee that interference will not occur in a particular installation.*

*If this equipment does cause harmful interference to radio or television reception, which can be determined by turning the equipment off and on, the user is encouraged to try to correct the interference by one or more of the following measures:*

- Reorient or relocate the receiving antenna.*
- Increase the separation between the equipment and receiver.*

- *Connect the equipment into an outlet on a circuit different from that to which the receiver is connected.*
- *Consult the dealer or an experienced radio/TV technician for help.*



- *This device complies with Part 15 of the FCC Rules. Operation is subject to the following two conditions:
  - 1) *this device may not cause harmful interference, and*
  - 2) *this device must accept any interference received, including interference that may cause undesired operation.**



- *This device complies with FCC radiation exposure limits set forth for an uncontrolled environment. This transmitter must not be co-located or operating in conjunction with any other antenna or transmitter.*

**FCC ID: 2ANHPLGT-233**

## EMC Guidance

---

*This product needs special precautions regarding EMC and needs to be installed and put into service according to the EMC information provided, and this unit can be affected by portable and mobile RF communications equipment.*



### **CAUTION**

- *Do not use a mobile phone or other devices that emit electromagnetic fields, near the unit. This may result in incorrect operation of the unit.*
- *This unit has been thoroughly tested and inspected to assure proper performance and operation!*
- *This machine should not be used adjacent to or stacked with other equipment and that if adjacent or stacked use is necessary, this machine should be observed to verify normal operation in the configuration in which it will be used.*



**Accessory Information:**

Item	Cable Length	Manufacturer & Address
Power cord (adapter)	0.1 m	Shenzhen Hongyi Electronic Technology Co., Ltd. A05-1, 2/F, 3 Bldg, EC building, Yu Anju, Baoan District, Shenzhen, China
Electrode lead hose	0.3 m	Guangzhou Longest Science & Technology Co., Ltd. 5&6F, Building B4, No.11, Kaiyuan Avenue, Science City, Guangzhou Hi-tech Industrial Development Zone, 510530 Guangzhou, Guangdong Province, P.R. China

**Bluetooth Specifications:**

Bluetooth Version: 4.0
Frequency Range: 2.4GHz ~ 2.4835GHz
Modulation Type: GFSK
Effective Radiated Power: +4 dBm

## Guidance and manufacture's declaration – electromagnetic emission

The LGT-233 is intended for use in the electromagnetic environment specified below. The customer of the user of the LGT-233 should assure that it is used in such an environment.

Emission test	Compliance	Electromagnetic environment – guidance
RF emissions CISPR 11	Group 1	The LGT-233 use RF energy only for its internal function. Therefore, its RF emissions are very low and are not likely to cause any interference in nearby electronic equipment.
RF emission CISPR 11	Class B	The LGT-233 is suitable for use in all establishments, including domestic establishments and those directly connected to the public low-voltage pump supply network that supplies buildings used for domestic purposes.
Harmonic emissions IEC 61000-3-2	Class A	
Voltage fluctuations/ flicker emissions IEC 61000-3-3	Complies	

### Guidance and manufacture's declaration – electromagnetic immunity

The LGT-233 is intended for use in the electromagnetic environment specified below. The customer or the user of LGT-233 should assure that it is used in such an environment.

Immunity test	IEC 60601 test level	Compliance level	Electromagnetic environment - guidance
Electrostatic discharge (ESD) IEC 61000-4-2	±6 kV contact ±8 kV air	±6 kV contact ±8 kV air	Floors should be wood, concrete or ceramic tile. If floor are covered with synthetic material, the relative humidity should be at least 30%.
Electrical fast transient/ burst IEC 61000-4-4	±2 kV for power supply lines ±1 kV for input/output lines	±2kV for power supply lines	Mains power quality should be that of a typical commercial or hospital environment.
Surge IEC 61000-4-5	± 1 kV line(s) to line(s) ± 2 kV line(s) to earth	±1 kV differential mode	Mains power quality should be that of a typical commercial or hospital environment.
Voltage dips, short interruptions and voltage	<5% $U_T$ (>95% dip in $U_T$ ) for 0.5 cycle 40% $U_T$ (60% dip in $U_T$ ) for 5 cycles	<5% $U_T$ (>95% dip in $U_T$ ) for 0.5 cycle 40% $U_T$ (60% dip in $U_T$ ) for 5 cycles	Mains power quality should be that of a typical commercial or hospital environment. If the user of the LGT-233 requires continued

variations on power supply input lines IEC 61000-4-11	70% $U_T$ (30% dip in $U_T$ ) for 25 cycles <5% $U_T$ (>95% dip in $U_T$ ) for 5 sec	70% $U_T$ (30% dip in $U_T$ ) for 25 cycles <5% $U_T$ (>95% dip in $U_T$ ) for 5 sec	operation during power mains interruptions, it is recommended that the LGT-233 be powered from an uninterruptible power supply or a battery.
Power frequency (50Hz/60Hz) magnetic field IEC 61000-4-8	3 A/m	3 A/m	Power frequency magnetic fields should be at levels characteristic of a typical location in a typical commercial or hospital environment.
NOTE $U_T$ is the a.c. mains voltage prior to application of the test level.			

### Guidance and manufacture's declaration – electromagnetic immunity

The LGT-233 is intended for use in the electromagnetic environment specified below. The customer or the user of the LGT-233 should assure that it is used in such an environment.

Immunity test	IEC 60601 test level	Compliance level	Electromagnetic environment - guidance
Conducted RF IEC 61000-4-6	3 Vrms 150 kHz to 80 MHz	3 Vrms	Portable and mobile RF communications equipment should be used no closer to any part of the LGT-233, including cables, than the recommended separation distance calculated from the equation applicable to the frequency of the transmitter. <b>Recommended separation distance</b> $d = 1.2 \sqrt{P}$
Radiated RF IEC 61000-4-3	3 V/m 80 MHz to 2.5 GHz	3 V/m	$d = 1.2 \sqrt{P}$ 80 MHz to 800 MHz $d = 2.3 \sqrt{P}$ 800 MHz to 2.5 GHz  Where P is the maximum output power rating of the transmitter in watts (W) according to the transmitter

			<p>manufacturer and <math>d</math> is the recommended separation distance in metres (m).</p> <p>Field strengths from fixed RF transmitters, as determined by an electromagnetic site survey,<sup>a</sup> should be less than the compliance level in each frequency range.<sup>b</sup></p> <p>Interference may occur in the vicinity of equipment marked with the following symbol:</p> 
<p>NOTE 1 At 80 MHz and 800 MHz, the higher frequency range applies.</p> <p>NOTE 2 These guidelines may not apply in all situations. Electromagnetic propagation is affected by absorption and reflection from structures, objects and people.</p>			<p>a Field strengths from fixed transmitters, such as base stations for radio (cellular/cordless) telephones and land mobile radios, amateur radio, AM and FM radio broadcast and TV broadcast cannot be predicted theoretically with accuracy. To assess the electromagnetic environment due to fixed RF transmitters, an electromagnetic site survey should be considered. If the measured field strength in the location in which the LGT-233 is used exceeds the applicable RF compliance level above, the LGT-233 should be observed to verify normal operation. If abnormal performance is observed, additional measures may be necessary, such as re-orienting or relocating the LGT-233.</p> <p>b Over the frequency range 150 kHz to 80 MHz, field strengths should be less than 3 V/m.</p>

### Recommended separation distances between portable and mobile RF communications equipment and the LGT-233

The LGT-233 is intended for use in an electromagnetic environment in which radiated RF disturbances are controlled. The customer or the user of the LGT-233 can help prevent electromagnetic interference by maintaining a minimum distance between portable and mobile RF communications equipment (transmitters) and the LGT-233 as recommended below, according to the maximum output power of the communications equipment.

Rated maximum output power of transmitter (W)	Separation distance according to frequency of transmitter (m)		
	150 kHz to 80 MHz $d = 1.2 \sqrt{P}$	80 MHz to 800 MHz $d = 1.2 \sqrt{P}$	800 MHz to 2.5 GHz $d = 2.3 \sqrt{P}$
0.01	0.12	0.12	0.23
0.1	0.38	0.38	0.73
1	1.2	1.2	2.3
10	3.8	3.8	7.3
100	12	12	23

For transmitters rated at a maximum output power not listed above, the recommended separation distance  $d$  in metres (m) can be estimated using the equation applicable to the frequency of the transmitter, where  $P$  is the maximum output power rating of the transmitter in watts (W) according to the transmitter manufacturer.

NOTE 1 At 80MHz and 800MHz, the separation distance for the higher frequency range applies.

NOTE 2 These guidelines may not apply in all situations. Electromagnetic propagation is affected by absorption and reflection from structures, objects and people.

## Clinical Instructions

---

Before a treatment with the **MStim Drop LGT-233**, a correct examination and diagnosis should be performed.

### Indications

---

The **MStim Drop LGT-233** can alleviate acute and chronic pain, also can stimulate nerves and muscles, causing muscle contraction.

### Contraindications

---

Patients with the following disease are forbidden to use the **MStim Drop LGT-233**:

- 1) Patient with severe heart failure or arrhythmia, and patient with pacemaker;
- 2) Patient with venous thrombosis or thrombophlebitis;
- 3) Patient who is in the acute or critical stage of important organ disease;



- 4) *Patient whose treatment area with bleeding tendency, metal matter or tuberculous lesions;*
- 5) *Patients who cannot provide sensory feedback for stimulation (unable to express or have difficulty in communication), such as mental disease.*

## **Adverse Effects**

---

*You should stop using the device and consult your doctor if you experience adverse reactions from the device. Possible adverse reactions may include the following:*

- *skin irritation beneath the electrodes;*
- *burns beneath the electrodes;*
- *headaches or other painful sensations.*

## Working Principle

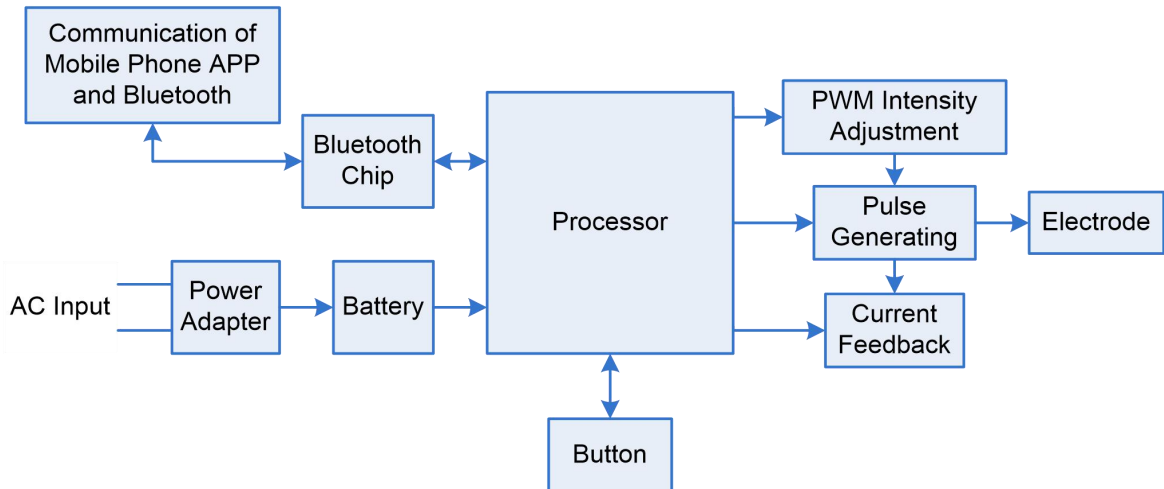

# ***Inspection of the Goods***

---

## ***1. Unpacking the Unit***

---

*The unit is generally delivered with the packaging material supplied by the manufacturer. Proceed as follows:*

- *Position the transport packaging so that the arrows are pointing upward.*
- *Remove the transport packaging upward.*
- *Remove the remaining foam material.*

## ***2. Inspections***

---

*Immediately upon unpacking the unit, perform the following steps:*

- 1) *Verify the delivery documents to make sure that the delivery is complete.*
- 2) *Check the external components and accessories for possible damage due to transport.*
- 3) *Verify that the packaging contains the following:*

No.	Item Name	Amounts	Unit
1	<b>LGT-233</b> main unit	1	piece
2	Power adapter	1	piece
3	Electrode lead hose	2	pieces
4	Self-adhesive electrode with magnetic connection: 50mm×50mm (square)	4	pieces
5	Leg bandage	1	piece
6	Certificate of quality	1	piece
7	Warranty card	1	piece
8	Installation checklist	1	piece
9	User manual	1	piece

*Other parts of **MStim Drop LGT-233** are available as accessory on demand. Visit website [www.longest.cn](http://www.longest.cn) to obtain more information.*

## Overview of the Unit

---

### 1. Nomenclature

---

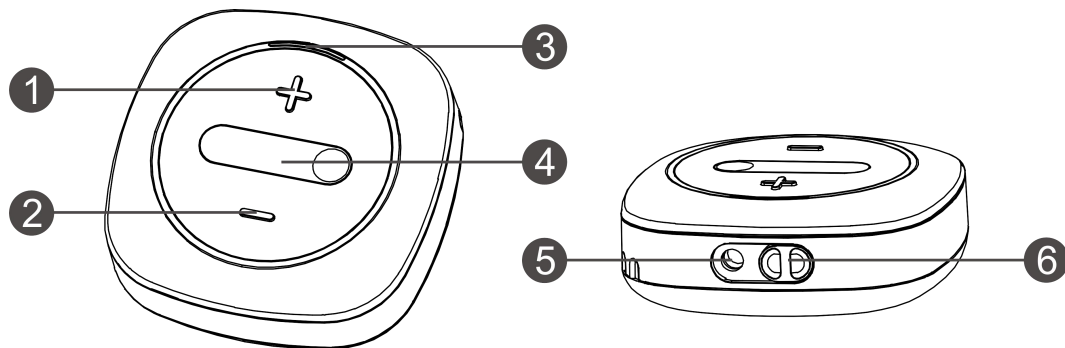

1	Increasing intensity button	4	ON/ OFF button
2	Decreasing intensity button	5	Output socket: connect electrode lead hose
3	Indicator light: see table: meaning of indicator light	6	Micro-USB port: connect power adapter. Slide the slider to output sockets when charging.

**Table: meaning of indicator light**

Status	Indicator color	Way of flashing
Power off	None	None
Bluetooth is connecting	Green	Flash at 3Hz frequency. Flash at 1Hz after successful connection
Ready	Green	Flash at 1Hz frequency
Stimulation on (may be $> 10\text{mA}$ (r.m.s) or $10\text{V}$ (r.m.s))	Yellow <sup>*-1</sup>	Slight light
Low battery cannot be used	White	Flash at 3Hz frequency for 1s, and then turn off the unit.
Charging	Blue	Flash at 1Hz frequency
Fully charged	Blue	Always bright
Electrodes fall off during treatment	White	Flash at 1Hz frequency

**NOTE: The device can deliver an output of more than 10mA (r.m.s) or 10V (r.m.s) and the output intensity is set more than 10 mA.**

## 2. Accessories

---

### 2.1 Electrode lead hose



*The electrode lead hose connects with the main unit and electrodes.*

### 3.2 Self-adhesive electrode with magnetic connection

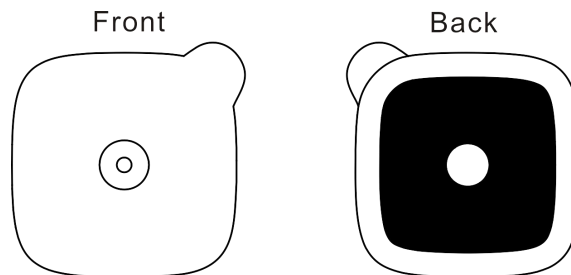

No.	Item name	Remark
1	Self-adhesive electrode with magnetic connection: 50mm×50mm (square)	Standard
2	Self-adhesive electrode with magnetic connection: $\Phi$ 32mm (round)	Optional
3	Self-adhesive electrode with magnetic connection: $\Phi$ 50mm (round)	Optional
4	Self-adhesive electrode with magnetic connection: 40mm×60mm (rectangle)	Optional



5	Self-adhesive electrode with magnetic connection: 50mm×90mm (rectangle)	Optional
6	Self-adhesive electrode with magnetic connection: 80mm×130mm (rectangle)	Optional

## 2.2 Leg Bandage

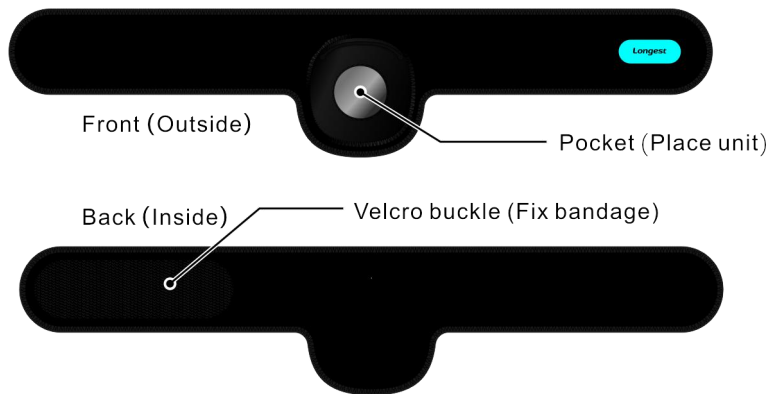

## ***MStim Drop Application***

---

*MStim Drop LGT-233 can only be used with the software provided by our company.*

- ◆ ***Name of the software: MStim Drop***
- ◆ ***Release Version: 1***
- ◆ ***Software operating environment:***

*Android 4.3 or later mobile phone, with 4.0 Bluetooth.*

*iOS 8.0 or later iPhone mobile phone, with 4.0 Bluetooth.*

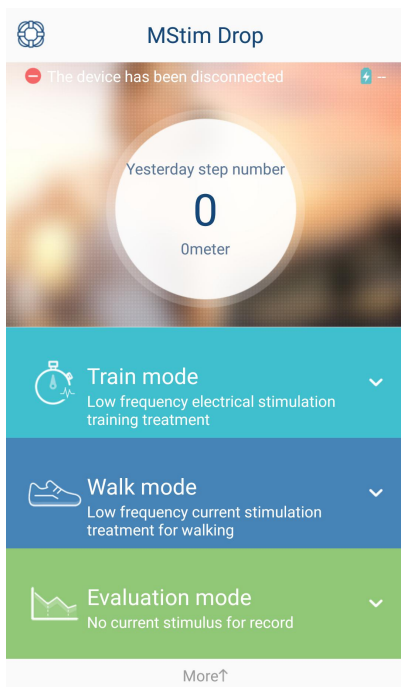

## 1. Install MStim Drop Application

Click the MStim Drop Application installation package (APK file) on your phone, and follow the prompts to install the application.

## 2. Open MStim Drop Application

After the MStim Drop Application is installed properly, it



will appear on your phone desktop. Click the icon and the main interface of the MStim Drop appear, as shown on the left.

### 3. Connect the Device

Click “click here to connect the device” at the main interface to connect MStim Drop Application which on the phone and the device via Bluetooth. The APP will search the devices automatically, as shown on the below. When it has searched, the interface will display the device which has found. Click “Not binding” to connect the device till becomes “Connected” which means the device had connected. The Bluetooth address of the unit is below the product model. You can paste this Bluetooth address on the unit to distinguish other unit. Click  to view the device information, such as battery percentage, hardware and software version of device.

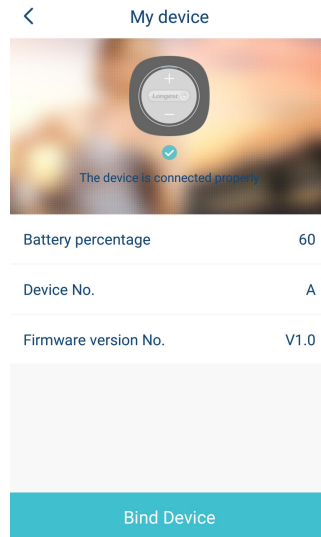
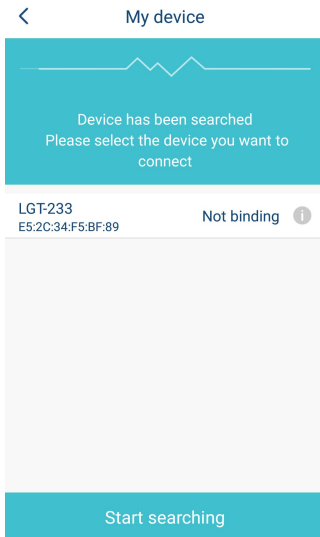
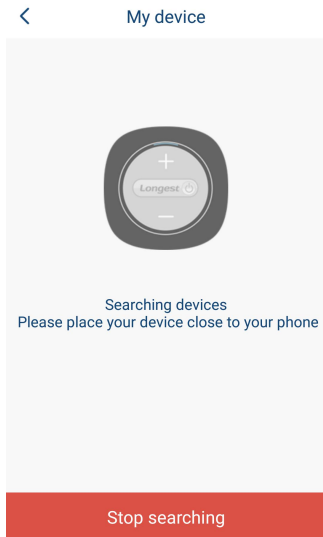

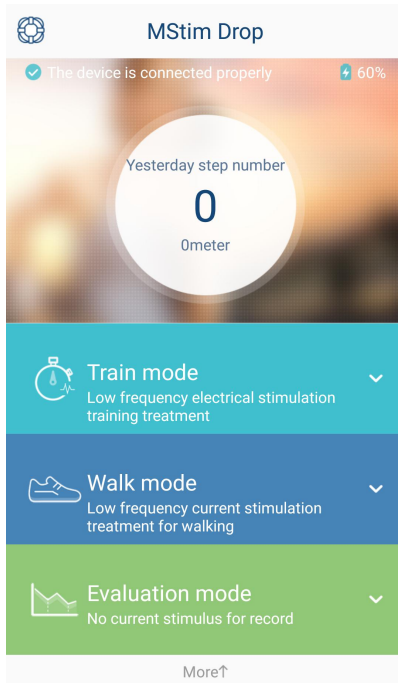

## 4. Main Interface

Open **MStim Drop**, you can see the main interface, as shown on the left.

The software has the power display function; the main interface of the upper right corner shows the power of the main unit.

There are three modes on the MStim Drop: Train Mode, Walk Mode and Evaluation Mode.

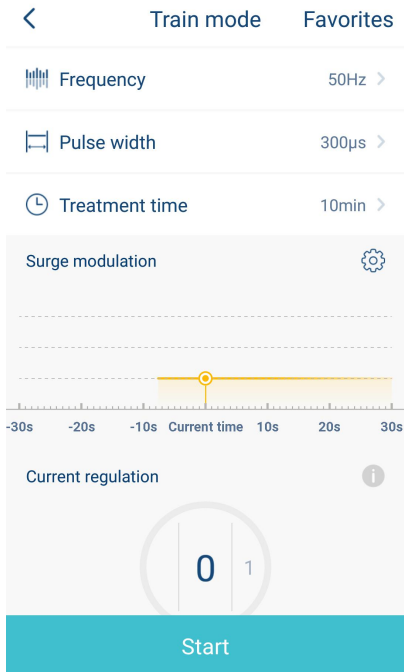

## 4.1 Train Mode Interface

### 1) Enter Train Mode interface

Click *Train Mode* at the main interface to enter the this interface, as shown on the left.

The current regulation module displays the units which had connected. The gray circle indicates that the device did not be connected. Once it connects, it will become cyan.

## Setting surge modulation

Schematic

Interval time Ramp up time Hold time Ramp down time Interval time

- Ramp up time 1.0s >
- Hold time 3.0s >
- Ramp down time 1.0s >
- Interval time 10.0s >

OK

## 2) Set the parameters

**Table: Parameter setting of Train Mode**

Parameter Setting	Range	Default	Stepping
Frequency Hz	1-120	40	1
Pulse Duration $\mu$ s	50-500	300	10
Surge Modulation* <sup>-1</sup>			
Ramp up time s	0.5-5.0	1.0	0.5
Hold time s	1.0-30.0	3.0	1.0
Ramp down time s	0.5-5.0	1.0	0.5
Interval time s	2.0-60.0	10.0	1.0
Treatment time min	1-60	10	1
Output Intensity mA* <sup>-2</sup>	0-100	0	1

\*<sup>1</sup> The Surge Modulation Interface is as shown on the left.

\*<sup>2</sup> The output intensity can only be adjusted after starting.



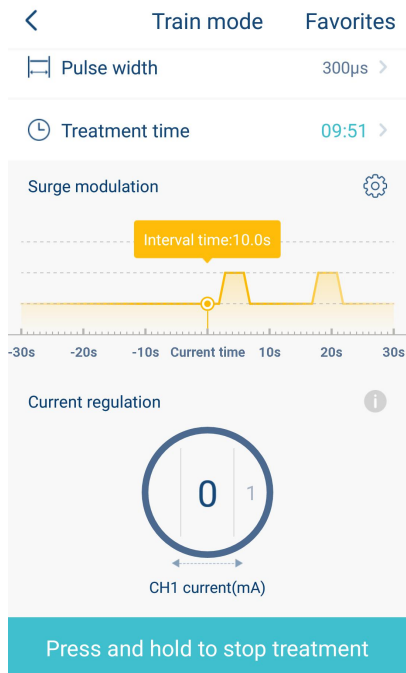





### 3) Start treatment

When the parameters are set, click the start button to start the treatment. Meanwhile the circles turn blue.

### 4) Adjust output intensity

Click the start button, the output intensity can be adjusted. Click  button, interface pop-up tip:

 **Current tips** 

 Frequency 80Hz ?

The current should be increased slowly from a small value to avoid the stimulus increase too strong. Product current regulation are in the safe range, please rest assured that use.

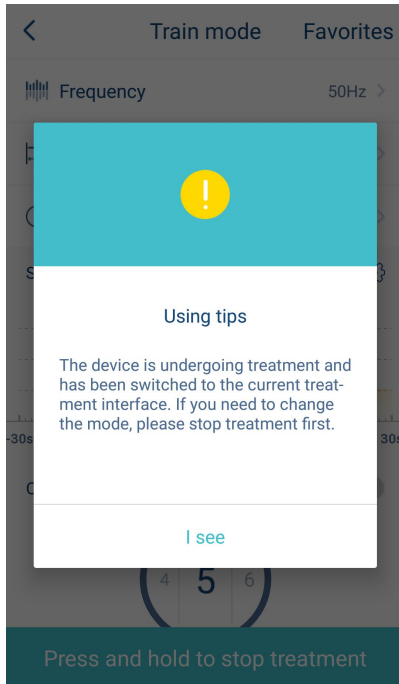

## 5) **Tips of change mode**

*During the treatment, if you click on other mode, the interface will automatically go to the current treatment interface, and appear as shown on the left. At this time, if you want to change the mode, long press the stop button to stop the current treatment.*

## 6) **End of the treatment**

*At the end of the treatment, the unit stops output and returns to the pre start state. The indicator is switched from yellow to green and flashes at 1Hz frequency, while the mobile application interface shows "the treatment is finish."*

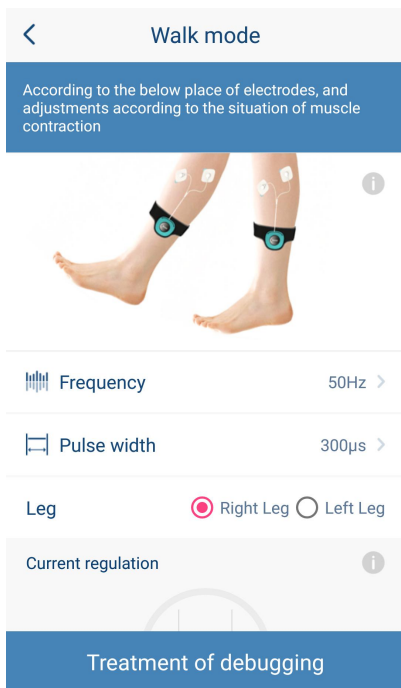

## 4.2 Walk Mode Interface

### 1) Enter Walk Mode interface

Click Walk Mode at the main interface to enter this interface, as shown on the left.

The current regulation module displays the units which had connected. The gray circle indicates that the device did not be connected. Once it connects, it will become green.

### 2) Placement guidance

Click  at this interface, then will pop-up prompt box.

You can place the electrodes according this guidance.

### 3) Select Right or Left Leg

Select the left or right leg according to the actual situation and it will affect the measurement of the angle.

Walk mode



Frequency 50Hz >

Pulse width 300μs >

Leg  Right Leg  Left Leg

Current regulation i

9 10 11

CH1 current(mA)

stop Next step

#### 4) Set the parameters

**Table: the parameter setting of Walk Mode**

Parameter Setting	Range	Default	Stepping
Frequency Hz	1-120	50	1
Pulse duration μs	50-500	300	10
Output intensity μA* <sup>1</sup>	0-1000	0	10

*\*<sup>1</sup> The output intensity can only be adjusted after starting.*

#### 5) Treatment of debugging

*After setting the output frequency and pulse duration, click debugging. Adjust the output current and frequency according to your muscle contraction.*

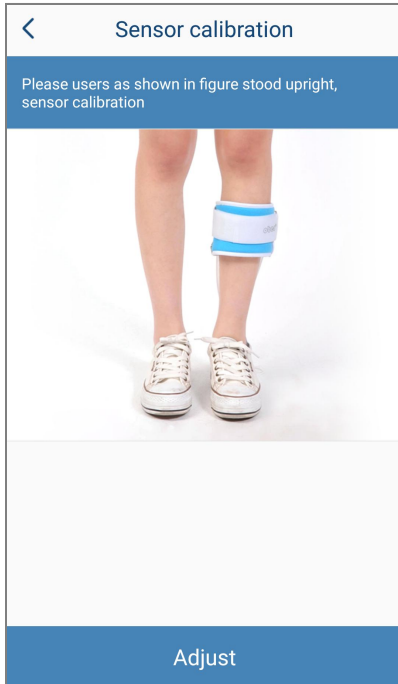

## 6) **Calibrate the sensor**

*After debugging, click Next step to jump to the interface of Sensor calibration.*

*At this stage, there is no electrical stimulation output. Stand upright according to the figure on the APP and click on "Calibrate" to calibrate the sensor.*

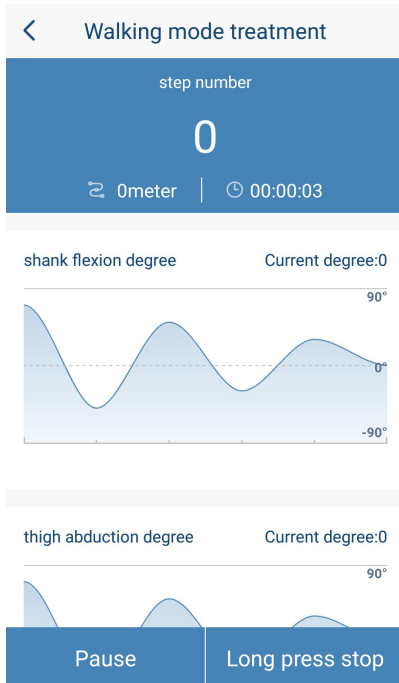

## 7) Enter treatment interface of Walking Mode

After the calibration is completed, it will automatically enter the walking mode treatment interface.

In this page, the leg flexion and extension angle and the thigh abduction angle can be recorded in real time; the number of walking steps, walking distance and walking time can be recorded.

## 8) Start treatment

Click the start button to start the treatment. The output current is the value of the previous debug, also you can adjusted according to the actual situation.

## 9) End of the treatment

At the end of the treatment, the unit stops output and returns to the pre start state. The indicator is switched from yellow to green and flashes at 1Hz frequency, while the mobile application interface shows "the treatment is finish."



## Evaluation mode

According to the below place of electrodes, and adjustments according to the situation of muscle contraction



Evaluation mode: for there is no current stimulation pattern on foot, record your legs, thighs bending Angle when walking. With walking model to evaluate contrast with the current stimulation.

Leg

 Right Leg
  Left Leg

Next step

### 4.3 Evaluation Mode Interface

#### 1) Enter Evaluation Mode interface

Click Evaluation Mode at the main interface to enter this interface, as shown on the left.

You can place the electrodes to the figure on the APP.

Select the left or right leg according to the actual situation and it will affect the measurement of the angle.

Then click "Next step".

#### 2) Calibrate the sensor

Stand upright according to the figure on the APP and click on "Calibrate" to calibrate the sensor.

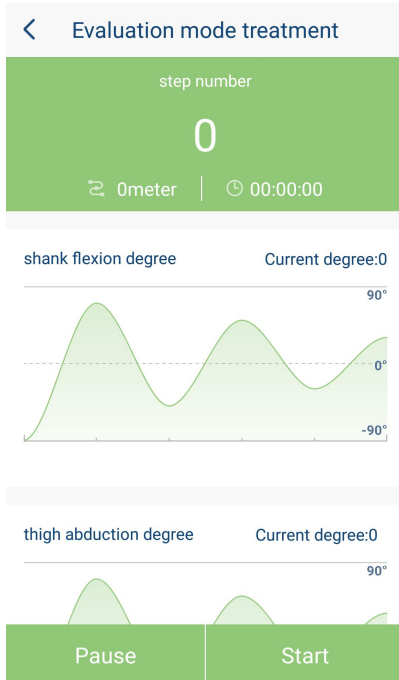

### 3) Enter treatment interface of Evaluation Mode

*After the calibration is completed, it will automatically enter the Evaluation Mode treatment interface. In this page, the leg flexion and extension angle and the thigh abduction angle can be recorded in real time; the number of walking steps, walking distance and walking time can be recorded.*



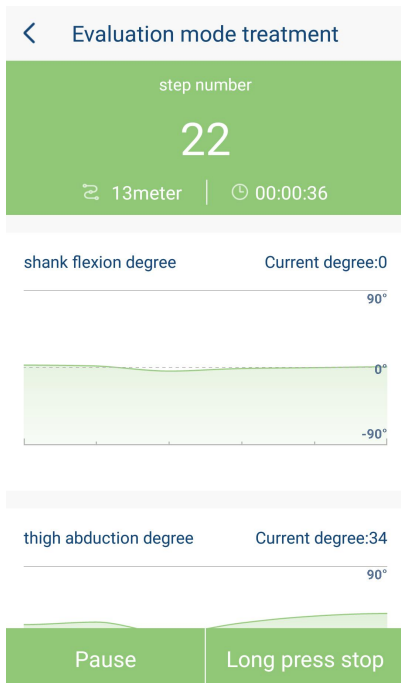

#### 4) **Start treatment**

*Click the start button to start the treatment.*

#### 5) **End of the treatment**

*At the end of the treatment, the unit returns to the pre start state. The indicator is switched from yellow to green and flashes at 1Hz frequency.*

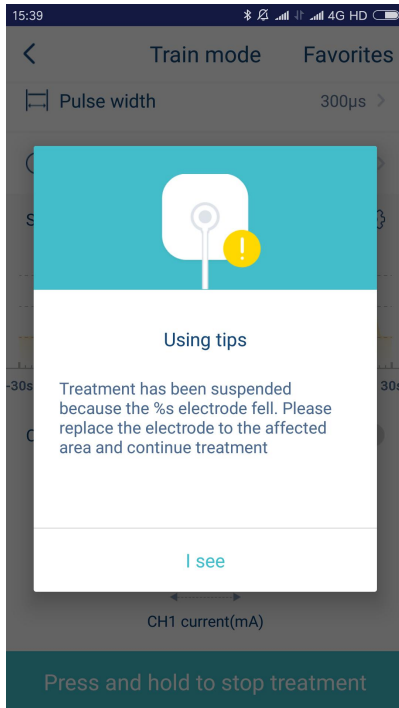

## 5. Open circuit tip

*In the train mode and walking mode, when the output is disconnected, the indicator on the unit is displayed in white and flashing at 1 Hz, the treatment time stops counting down. In this case, check the connection of the electrodes and press the "Start" button to restart the treatment.*

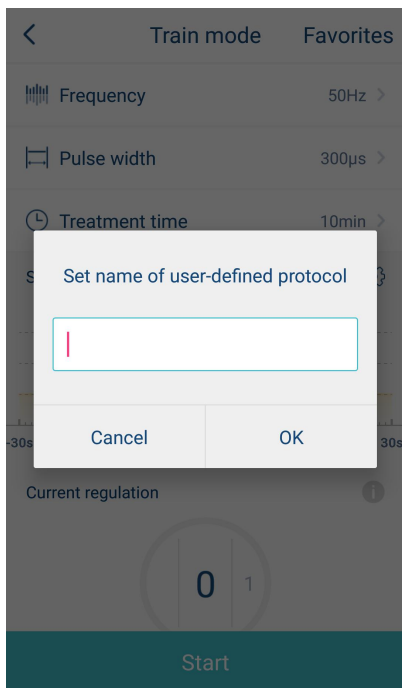

## 6. About My favors

### 1) Add user-defined protocol

*MStim Drop can save user-defined protocols in train mode. Click Train Mode at the main interface to enter the interface, set the frequency, pulse duration, treatment time and surge modulation parameters, click “Favorites” in the upper right corner, then pop up the page as shown on the left, set the name of the user-defined protocol and click OK button, the collection is successful.*

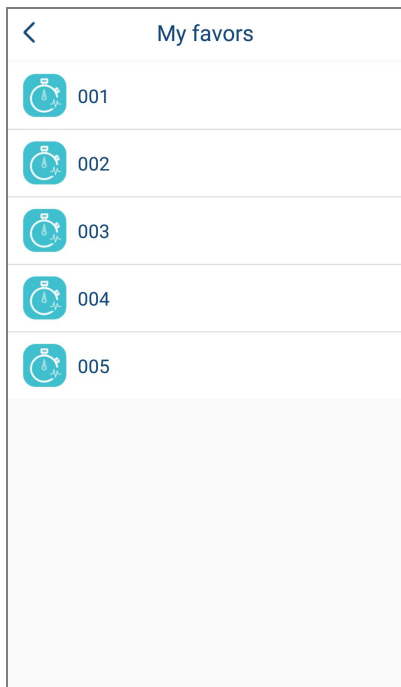

## 2) **Enter treatment from a user-defined protocol**

Click the icon  which in the upper right corner of the main interface, or swipe the interface in the main

interface to view more. Click the icon  to enter the user-defined protocol. Choose one user-defined protocol you want and click to enter the detail page which shows the treatment parameters of the user-defined protocol. Click "Enter Treatment" to enter the treatment. For details, please refer to clause **4.1 Train Mode Interface** of this chapter.

## 3) **Delete user-defined protocol**

In the user-defined protocol interface, swipe the user-defined protocol to the left and click "Delete".



Help center



Hi, what can I do for you?

[✔ Using guidance >](#)[① FAQ >](#)

## 7. Help Center



Click the icon  in the upper right corner of the main interface, or slide the interface in the main interface to

see more, click the icon , enter the help center interface.

< Using guidance



Train mode



Walk mode













Evaluation mode



### 7.1 Using guidance

*There is some introduction of how to operation the **MStim Drop LGT-233** in using guidance, which is convenient for you to understand the use of device.*



- What is the Longest MStim Arth?? 
- What is TENS? 
- How does TENS work? 
- What is MCR? 
- How does MCR work? 
- Is there any risk of long-term use of electrical stimulation? 
- What are the applicable groups of MStim Arth? 
- What are the contraindications of MStim Arth? 
- How to adjust the current intensity? 
- Will it be interrupted by other programs on my phone or tablet, or by an incoming / outgoing call? 

## 7.2 Common problem

*MStim Drop Application includes a variety of common problems, you can learn more about the **MStim Drop LGT-233** and treatment.*

# Operation Guidance

---

## 1. Preparing for use

---

### 1.1 Charging the unit

To be able to use the device, you first have to charge the unit. Put one side of power adapter connects with the unit; another side connects with the power socket. The status indicator on the unit flashes blue during charging. The status indicator stops flashing when the battery is fully charged.

**NOTE:** *If the rechargeable battery of the units is not fully charged when you start a treatment, the batteries may run out during the treatment. We advise you to always fully charge the unit before you start a treatment.*

**NOTE:** *Always disconnect the power charger from the mains after use.*



**Do not use when the unit is charging.**



## **1.2 Turn on the unit**

*Press the ON/OFF button to turn on the unit to standby.*

## **1.3 Open the MStim Drop and Connecting**

*Turn on the MStim Drop Application on your phone and connect the unit to your phone via Bluetooth. Two main units can be connected at the same time, and two units can perform electrical stimulation simultaneously.*

## **2. Starting a Treatment**

---

### **◆ Train Mode**

- 1) Clean the skin and pace the electrodes: Use alcohol or soapy water to clean the skin, remove the grease of skin. After skin drying, place electrodes according the schematic of MStim Drop APP.*
- 2) Connect the unit: Connect one end of electrode lead hose to the electrodes, the other end to the unit.*
- 3) Select Train Mode and set parameters: Click Train Mode at the main interface to enter the Train Mode interface, set parameters such as frequency, pulse duration and treatment time according to the actual situation (see the 4.4.1 clause in fourth chapter MStim Drop*

*Application).*

- 4) Start Treatment: Click the start button and the treatment begins.*
- 5) Adjust output intensity: You can adjust the output intensity in the MStim Drop interface, or through "+/-" button on the unit. The output intensity should be increased slowly from small values to avoid excessive stimulation. Since your body initially adapts to the intensity of the stimulation, you may have to adjust the intensity level after some time to ensure optimal stimulation.*

## ◆ **Walk Mode**

- 1) Clean the skin and pace the electrodes: Use alcohol or soapy water to clean the skin, remove the grease of skin. After skin drying, place electrodes according the schematic of MStim Drop APP.*
- 2) Connect the unit: Connect one end of electrode lead hose to the electrodes, the other end to the unit.*
- 3) Select Walk Mode and debug: Click Walk Mode at the main interface to enter the interface, click treatment of debugging, and adjust output intensity.*
- 4) Fix Leg Bandage: After finish debug, fix the strap on the calf according to the schematic of MStim Drop APP, and place the unit into the pocket of Leg Bandage.*

- 5) *Calibrate the sensor: click “next step” at MStim Drop APP, Stand according to the schematic of APP, click “Adjust”.*
- 6) *Start treatment: After calibration is completed, it is automatically transferred to the treatment interface. Click start button, then you can start your walking training.*
- 7) *Adjust output intensity: You can adjust the output intensity in the MStim Drop interface, or through “+/-” button on the unit. The output intensity should be increased slowly from small values to avoid excessive stimulation. Since your body initially adapts to the intensity of the stimulation, you may have to adjust the intensity level after some time to ensure optimal stimulation.*

◆ **Evaluation Mode**

- 1) *Fix Leg Bandage: After finish debug, fix the strap on the calf according to the schematic of MStim Drop APP, and place the unit into the pocket of Leg Bandage.*
- 2) *Select Evaluation Mode and calibrate: Click Evaluation Mode at the main interface to enter the interface, Stand according to the schematic of APP, then click “next step” to enter the Sensor calibration interface, click “Adjust”.*
- 3) *Start Training: After calibration is completed, it is automatically transferred to the treatment interface. You can press the start button to start evaluation.*

### **3. The End of Treatment**

---

*At the end of the treatment, the unit stops output and returns to the pre start state. The indicator is switched from yellow to green and flashes at 1Hz frequency, while the mobile application interface shows “the treatment is finish.”*

*Remove the leg bandage and electrode lead hose after treatment. The main unit, electrode lead hose and the leg bandage are put into the box, placed in a cool and ventilated place, ready for the next use.*

## Care and Maintenance

---

### 1. Cleaning

---

- 1) Please turn off the device before the cleaning and disinfection operation;
- 2) For the main unit cleaning, what recommended are a clean, soft damp cloth for stains, and a clean, soft dry cloth for dust in the surface of the main unit;
- 3) Clean the Leg Bandage: Wipe the surface with a damp cloth or antiseptic wipe after use. It can be washed if necessary: moderate amount of neutral detergent, soak for a short time, be careful, gently rinse and dry naturally. Not machine washable, rubbed and bleached.



**CAUTION**

***Do not clean the main unit with organic solvent such as gasoline or diluents, otherwise damage will be happened to the main unit such as deformation and falling off of the paint.***

## 2. Routine Maintenance

---

*If it is used in accordance with the instructions of the user manual, the device does not need a particular regular maintenance.*

*Manufacturer will provide circuit diagrams, component part lists, descriptions, calibration instructions to assist to service personnel in parts repair.*

*The unit and accessories must be checked at regular intervals.*

- 1) *Check the power line to ensure if there is no distortion, fracture, etc. These circumstances may cause fire hazard. Please replace a new power line immediately.*
- 2) *Replace the electrodes if:*
  - they are damaged or torn.*
  - they are past the use-by date.*
  - they have lost their adhesive power. Never use plaster or tape to attach them to your skin.*
  - stimulation feels less strong.*
  - when the stimulation is uncomfortable, i.e. when you experience an unpleasant stinging or biting sensation.*

**NOTE: Always replace the electrodes with electrodes recommended for this device by the manufacturer.**

**WARNING**

*Never perform unauthorized service work. All service work must be performed only by service technicians who have been authorized by the manufacturer.*

### **3. Disposal**



*For environmental reasons, do not dispose of the device in the household waste at the end of its useful life. Dispose of the unit at a suitable local collection or recycling point. Dispose of the device in accordance with EC Directive – WEEE (Waste Electrical and Electronic Equipment). If you have any questions, please contact the local authorities responsible for waste disposal.*



*This symbol indicates that batteries contain substances that may be harmful to human health and*

*the environment. Never dispose of batteries with normal household waste. Follow the local rules for separate collection of batteries. Correct disposal of batteries helps prevent potentially negative consequences for the environment and human health. The **MStim Drop LGT-233** contains a built-in rechargeable battery that cannot be removed by the user. Take them to an official collection point or a service centre to have the rechargeable battery removed.*



## Troubleshooting

*This chapter summarizes the most common problems you could encounter with the **MStim Drop** **LGT-233**. If you are unable to solve the problem with the information below, please call the distributors.*

Troubles	Possible causes	Solutions
1. The indicator does not light up at all when press the ON/OFF button	The battery of the unit is empty.	Charge the unit (see chapter Preparing for use').
2. The MStim Drop APP on the mobile phone could not connect with the unit.	1. The unit is not turn on; 2. Mobile phone Bluetooth is not open or mobile phone Bluetooth problems 3. the distance of the mobile phone and the unit is too far; 4. The unit has contacted another mobile. 5. The unit is asleep and Bluetooth is stopped; 6. Other reasons.	1. Turn on the unit; 2. Please turn on the Bluetooth on the mobile phone or change another mobile phone; 3. Please keep the mobile phone near the unit; 4. Disconnect the connected phone or restart the unit; 5. Restart the unit; 6. Turn off the APP background operation, restart the phone Bluetooth.

Troubles	Possible causes	Solutions
3. The status indicator on the unit flashed white and the unit switched off.	The battery of the unit is empty.	Charge the unit (see chapter 'Preparing for use').
4. There is not output.	<ol style="list-style-type: none"> <li>1. Did not press the start button;</li> <li>2. Did not adjust the output intensity;</li> <li>3. The electrode lead hose connected badly;</li> <li>4. The electrode lead hose has been damaged.</li> </ol>	<ol style="list-style-type: none"> <li>1. Press the start button;</li> <li>2. Adjust the output intensity;</li> <li>3. Re-connect the electrode lead hose;</li> <li>4. Replace a new electrode lead hose.</li> </ol>
5. Stimulation is uncomfortable.	<ol style="list-style-type: none"> <li>1. The output intensity is too high;</li> <li>2. Electrodes are too close together;</li> <li>3. Damaged or worn electrodes or electrode lead hoses;</li> <li>4. Electrode active area size is too small.</li> </ol>	<ol style="list-style-type: none"> <li>1. Decrease the output intensity;</li> <li>2. Reposition the electrodes;</li> <li>3. Replace;</li> <li>4. Replace electrodes with ones that have an active area no less than 25.0cm<sup>2</sup>.</li> </ol>

Troubles	Possible causes	Solutions
6. The MStim Drop APP on the mobile phone pop up tips "electrodes fall off", the indicator of the unit flashed white.	1. The electrode lead hose connected badly; 2. The electrodes are poor contact with the skin; 3. Electrodes do not stick well.	1. Re-connect the electrode lead hose; 2. Re-connect the electrodes; 3. Replace electrodes. Apply electrodes to a clean, dry surface.
7. The unit has output, but treatment without sensation.	The output intensity is too low.	Increase the output intensity.

## Technical Specifications

### 1. Stimulator Output Parameters

Channel:	One channel																	
Output Mode:	Synchronize output, Alternate output mode																	
Output Waveform:	Symmetrical biphasic asynchronous																	
Pulse Duration:	Adjustable, 50 $\mu$ s-500 $\mu$ s, stepping 10 $\mu$ s																	
Pulse Frequency:	Adjustable, 1Hz-120Hz, stepping 1Hz																	
Surge Modulation:	<table border="1"> <thead> <tr> <th>Parameter</th> <th>Range</th> <th>Stepping</th> </tr> </thead> <tbody> <tr> <td>Ramp up time (s)</td> <td>0.5–5.0</td> <td>0.5</td> </tr> <tr> <td>Hold time (s)</td> <td>1.0–30.0</td> <td>1.0</td> </tr> <tr> <td>Ramp down time (s)</td> <td>0.5–5.0</td> <td>0.5</td> </tr> <tr> <td>Interval time (s)</td> <td>2.0–60.0</td> <td>1.0</td> </tr> </tbody> </table>			Parameter	Range	Stepping	Ramp up time (s)	0.5–5.0	0.5	Hold time (s)	1.0–30.0	1.0	Ramp down time (s)	0.5–5.0	0.5	Interval time (s)	2.0–60.0	1.0
Parameter	Range	Stepping																
Ramp up time (s)	0.5–5.0	0.5																
Hold time (s)	1.0–30.0	1.0																
Ramp down time (s)	0.5–5.0	0.5																
Interval time (s)	2.0–60.0	1.0																
Output Intensity:	Adjustable, 0mA-100mA(p-p), stepping 1mA (at 500 $\Omega$ load)																	
Maximum Current (r.m.s):	the maximum current will be limited to 50mA r.m.s.at 500 $\Omega$ Load																	

Timer:	<p>a) Treatment time: 1min-60min, stepping 1min;</p> <p>b) Timer tolerance: <math>\pm 2\%</math>;</p> <p>c) When finish, the device can stop output and prompt.</p>
--------	---

## 2. Other specifications

Product Name	Portable electro-stimulation therapy device		
Model	LGT-233		
Software Release	Stimulator (main unit): A MStim Drop application: 1 (Android&iOS)		
Power Supply:	Adapter model:	HYI11-005 (USA)	HYI11-005 (Europe)
	Adapter supply voltage:	AC100-240V, 50/60Hz	
	Adapter output:	DC 5V, 2A.	
	<p>Battery: 3.7V, 1200mAh, lithium battery.</p> <p>Line Current Isolation: Patient disconnected when charging.</p>		
Expected Life	<ul style="list-style-type: none"> <li>● The expected life of the main unit is five years under normal usage. (Except for man-made damage). The Date of product manufacture see label on the device.</li> <li>● The expected life of the electrode lead hose and leg bandage are 12 months under normal usage. (Except for man-made damage).</li> <li>● The electrodes may be used up to 20 times. These numbers vary depending on the skin and /or climate conditions as well as care of usage and storage.</li> </ul>		

Rate Power:	6VA
Dimension:	59mm (W) × 59mm (L) × 22mm (H)
Weight:	60g (only main unit)
Classification:	<ul style="list-style-type: none"> <li>● Classification (IEC 60601-1): Class II, Type BF Applied Part;</li> <li>● Ingress Protection: IP22;</li> <li>● Mode of Operation: Continuous.</li> </ul>
Environmental conditions of operation:	<ul style="list-style-type: none"> <li>● Temperature: 5 to 40°C;</li> <li>● Rel. humidity: ≤80%;</li> <li>● Atmosphere Pressure: 86.0 to 106.0kPa.</li> </ul>
Environmental conditions of transport and storage:	<ul style="list-style-type: none"> <li>● Temperature: -20 to 55°C;</li> <li>● Rel. humidity: ≤93%;</li> <li>● Atmosphere Pressure: 86.0 to 106.0kPa.</li> </ul>
Environmental conditions of transport and storage between uses:	<ul style="list-style-type: none"> <li>● Temperature: -25 to 70°C;</li> <li>● Rel. humidity: ≤90%;</li> <li>● Atmosphere Pressure: 86.0 to 106.0kPa.</li> </ul> <p>NOTE: Except for Self-adhesive electrodes.</p>
Works with:	Requires a smart phone with Bluetooth 4.0, Android 4.3 (or later) or iOS 8.0 or later.

## ***Assistance***

---

*Every intervention on device must be performed by manufacturer. For any assistance intervention and original spare parts please contact the manufacturer at following address:*

### **GUANGZHOU LONGEST SCIENCE & TECHNOLOGY CO., LTD.**

Add: 5&6F, Building B4, No.11, Kaiyuan Avenue, Science City, Guangzhou Hi-tech Industrial Development Zone, 510530 Guangzhou, Guangdong Province, P.R. China

Tel: +86 20 6635 3999

Fax: +86 20 6635 3920

Email: [service@longest.cn](mailto:service@longest.cn)

Website: [www.longest.cn](http://www.longest.cn)

### **EU Representatives Information**

Lotus Global Co., Ltd

Company address: 1 Four Seasons Terrace West Drayton, Middlesex London, UB7 9GG, United Kingdom

Tel: +44 20 75868010, 70961611

Fax: +44 20 79006187

## Warranty

---

*The Manufacturer warrants that the **MStim Drop LGT-233** is free of defects in material and workmanship for the main unit. This warranty shall remain in effect for one year (12 months) from the date of original consumer purchase. If this Product fails to function during the one year warranty period due to a defect in material or workmanship, at the Manufacturer's Option, Manufacturer or the authorized dealer will repair this Product without charge.*

*The users should fill out the Warranty Card as soon as the product is installed and send a copy to **service@longest.cn** to have the warranty be valid. Damages due to non-adherence to the User Manual or wear of parts are excluded from warranty.*

*This Warranty Does Not Cover:*

- *Replacement parts or labor furnished by anyone other than the Manufacturer, the authorized dealer or a certified Company service technician.*
- *Defects or damage caused by labor furnished by someone other than Manufacturer, the authorized dealer or a certified Company service technician.*
- *Any malfunction or failure in the Product caused by product misuse, including, but not limited to, the failure to provide reasonable and necessary maintenance or any use that is inconsistent with the User Manual.*



# **Longest<sup>®</sup>**

**Guangzhou Longest Science & Technology Co., Ltd.**

5&6 F, Building B4, No.11, Kaiyuan Avenue, Science City,

Guangzhou Hi-tech Industrial Development Zone, 510530 Guangzhou, China

TEL: +86 20 6635 3999 FAX: +86 20 6635 3920 E-mail: [service@longest.cn](mailto:service@longest.cn)

WEB: [www.longest.cn](http://www.longest.cn)

FOR-MRRD0001-EN233  
Version Number: UM0.1