



---

## AMAZON ALEXA-ENABLED BLUETOOTH/WI-FI UNDER CABINET SMART MUSIC SYSTEM



### MODEL: JAS-725 USER MANUAL

PLEASE READ THIS USER MANUAL COMPLETELY BEFORE OPERATING THIS UNIT AND  
RETAIN THIS BOOKLET FOR FUTURE REFERENCE.

# IMPORTANT SAFETY INSTRUCTIONS

When used in the directed manner, this unit has been designed and manufactured to ensure your personal safety. However, improper use can result in potential electrical shock or fire hazards. Please read all safety and operating instructions carefully before installation and use, and keep these instructions handy for future reference. Take special note of all warnings listed in these instructions and on the unit.

1. Read these instructions – All the safety and operating instructions should be read before the appliance is operated.
2. Keep these instructions – The safety and operating instructions should be kept for future reference.
3. Heed all warnings – All warnings on the appliance and in the operating instructions should be adhered to.
4. Follow all instructions – All operation and use instructions should be followed.
5. Do not use this apparatus near water – The appliance should not be used near water; for example, near a bath tub, washbowl, kitchen sink, laundry tub, in a wet basement, or near a swimming pool.
6. Clean only with dry cloth – The appliance should be cleaned only as recommended by the manufacturer.
7. Do not block any ventilation openings. Install in accordance with the manufacturer's instructions. The appliance should be situated so that its location or position does not interfere with its proper ventilation. For example, the appliance should not be situated on a bed, sofa, rug, or similar surface that may block the ventilation openings; or placed in a built-in installation, such as a bookcase or cabinet that may impede the flow of air through the ventilation openings.
8. Do not install near any heat sources such as radiators, heat registers, stoves, or other apparatus (including amplifiers) that produce heat.
9. AC adaptor is used as disconnect device and it should remain readily operable during intended use. In order to disconnect the apparatus from the mains completely, the AC adaptor should be disconnected from the mains socket outlet completely.
10. Only use attachments / accessories specified by the manufacturer.
11. Use only with a cart, stand, tripod, bracket, or table specified by the manufacturer, or sold with the apparatus. When a cart is used, use caution when moving the cart/apparatus combination to avoid injury from tip-over.
12. Unplug this apparatus during lightning storms or when unused for long periods of time.
13. Refer all servicing to qualified service personnel. Servicing is required when the apparatus has been damaged in any way, such as power-supply cord or plug is damaged, liquid has been spilled or objects have fallen into the apparatus, the apparatus has been exposed to rain or moisture, does not operate normally, or has been dropped.
14. This appliance shall not be exposed to dripping or splashing water and that no object filled with liquids such as vases shall be placed on the apparatus.
15. Power Sources – The appliance should be connected to a power supply only of the type described in the operating instructions or as marked on the appliance. Do not overload wall outlet.
16. Do not attempt to dismantle, open or repair this product yourself. If a fault occurs, seek advice from your local qualified service technician or contact the distributor via the telephone number at the back of this instruction manual.
17. Nameplate is located on the top of product.



## CAUTION

### Follow the advice below for safe operations.

- To reduce the risk of fire, do not place any heating or cooking appliance beneath this unit.
- Stop operation immediately if any liquid or solid object should fall into the cabinet.
- If the unit is not to be used for a long period of time, make sure that all power sources are disconnected from the unit. Unplug the AC-DC adaptor from the wall outlet. Make it a practice to remove the AC-DC adaptor by grasping the plug and not by pulling the cord.

### ON PLACEMENT

- Do not use the unit in places, which are extremely hot, cold, dusty or humid.
- Install the JAS-725 as far as possible from a source of noise. (for example, refrigerator, microwave oven, fluorescent lamp, etc.)
- Do not restrict the airflow of the unit by placing it in a place with poor ventilation, by covering it with a cloth or by placing it on a carpet.

Should any trouble occur, remove the power source and refer servicing to qualified personnel.

## COMPLIANCE WITH FCC REGULATIONS

FCC ID : 2ANH7-393MET8025

This device complies with Part 15 of the FCC Rules. Operation is subject to the following two conditions:

- (1) this device may not cause harmful interference, and
- (2) this device must accept any interference received, including interference that may cause undesired operation.

NOTE: This equipment has been tested and found to comply with the limits for a Class B digital device, pursuant to Part 15 of the FCC Rules. These limits are designed to provide reasonable protection against harmful interference in a residential installation. This equipment generates, uses and can radiate radio frequency energy and, if not installed and used in accordance with the instructions, may cause harmful interference to radio communications. However, there is no guarantee that interference will not occur in a particular installation. If this equipment does cause harmful interference to radio or television reception, which can be determined by turning the equipment off and on, the user is encouraged to try to correct the interference by one or more of the following measures:

- Reorient or relocate the receiving antenna.
- Increase the separation between the equipment and receiver.
- Connect the equipment into an outlet on a circuit different from that to which the receiver is connected.
- Consult the dealer or an experienced radio/TV technician for help.

**CAUTION: Changes or modifications not expressly approved by the party responsible for compliance could void the user's authority to operate the equipment.**

This equipment complies with FCC radiation exposure limits set forth for an uncontrolled environment. This equipment should be installed and operated with minimum distance 20cm between the radiator & your body

## DEAR JENSEN® CUSTOMER

Selecting fine audio equipment such as the unit you've just purchased is only the start of your musical enjoyment. Now it's time to consider how you can maximize the fun and excitement your equipment offers. This manufacturer and the Electronic Industries Association's Consumer Electronics Group want you to get the most out of your equipment by playing it at a safe level. One that lets the sound come through loud and clear without annoying blaring or distortion and, most importantly, without affecting your sensitive hearing.

Sound can be deceiving. Over time your hearing "comfort level" adapts to higher volumes of sound. So what sounds "normal" can actually be loud and harmful to your hearing. Guard against this by setting your equipment at a safe level BEFORE your hearing adapts.

### **To establish a safe level:**

- Start your volume control at a low setting.
- Slowly increase the sound until you can hear it comfortably and clearly, and without distortion.

### **Once you have established a comfortable sound level:**

- Set the dial and leave it there.

Taking a minute to do this now will help to prevent hearing damage or loss in the future. After all, we want you listening for a lifetime.

### **We Want You Listening For a Lifetime**

Used wisely, your new sound equipment will provide a lifetime of fun and enjoyment. Since hearing damage from loud noise is often undetectable until it is too late, this manufacturer and the Electronic Industries Association's Consumer Electronics Group recommend you avoid prolonged exposure to excessive noise.

### **Customer's Record:**

The serial number of this product is found on its top cover. You should note the serial number of this unit in the space provided as a permanent record of your purchase to aid in identification in the event of theft or loss.

**Model Number: JAS-725**

**Serial Number: \_\_\_\_\_**

## PREPARATION FOR USE

Installing the JAS-725 under a cabinet

1. Make the position of the 3 holes by using the supplied template. Use a drill to make the holes.
2. When the cabinet door overhangs the shelf and obstructs the unit, you can adjust the unit/shelf height.
3. Install the unit with the supplied mounting kit.

Unpack the unit carefully to remove all the accessories from the packing. Verify that the following accessories are present before setting up the unit.

- Main Unit X 1
- AC adaptor X 1
- User Manual X 1
- Mounting kit X 1

## LOCATION OF CONTROLS

### MAIN UNIT

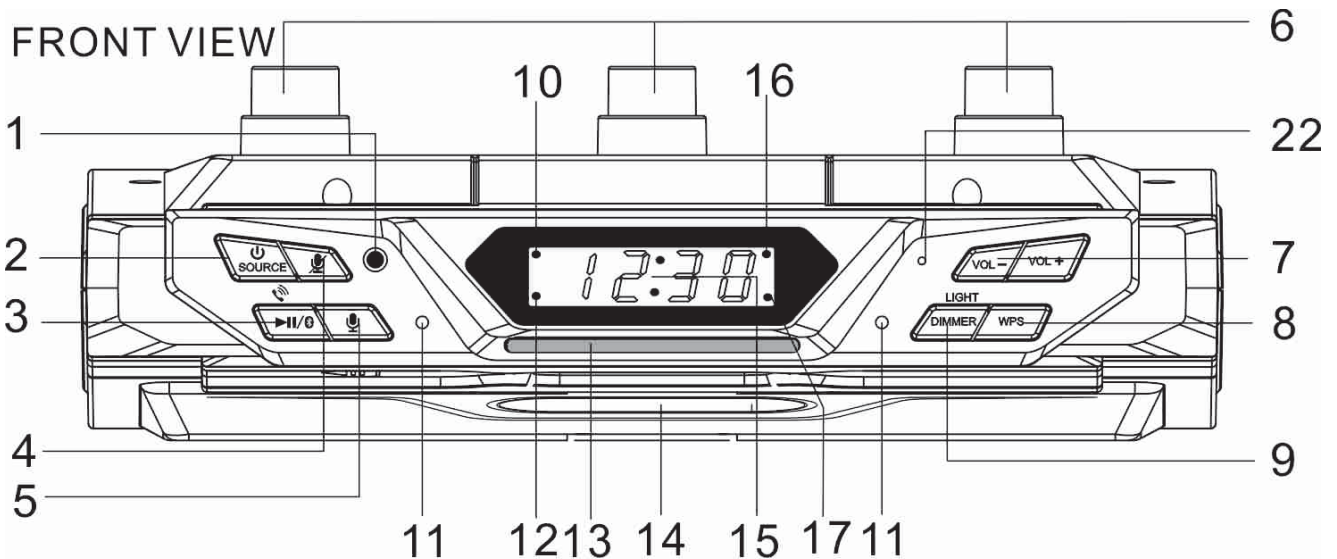

### REAR VIEW

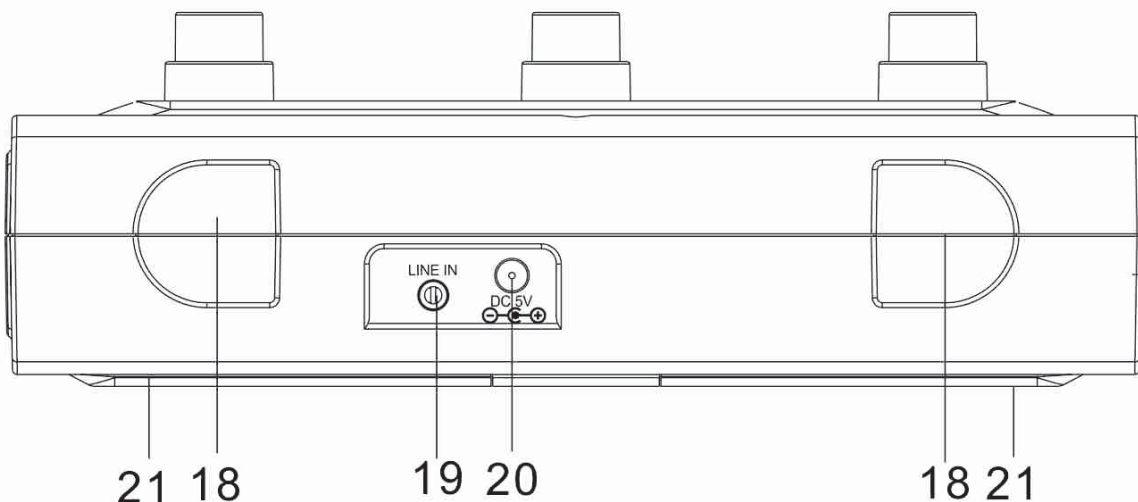



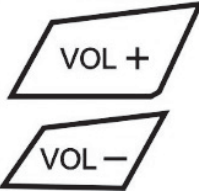

## CONTROLS

1. ALEXA MIC OFF Indicator
2. POWER ON / OFF / SOURCE Button
3. PLAY/PAUSE; BLUETOOTH PAIR; ANSWER CALL / END CALL BUTTON
4. MIC ON/OFF/FACTORY DATA RESET BUTTON
5. TAP TO TALK BUTTON
6. CABINET MOUNTING POINT
7. VOLUME+(UP) and VOLUME- (DOWN) BUTTONS
8. WPS BUTTON (Wi-Fi Protected Setup)
9. LIGHT ON/OFF; DISPLAY DIMMER BUTTON
10. LINE-IN MODE INDICATOR
11. MICROPHONES FOR ALEXA
12. PM TIME INDICATOR
13. ALEXA MODE / CONNECTION INDICATOR
14. LIGHT
15. LED DISPLAY
16. Wi-Fi MODE INDICATOR
17. BLUETOOTH MODE INDICATOR
18. CORD WRAP POINT
19. LINE-IN JACK
20. DC-IN JACK
21. SPEAKER
22. MICROPHONE FOR BLUETOOTH HANDFREE

## BUTTON FUNCTIONS

	<p><b>Power</b> Tap to power ON, press and hold to power OFF.</p> <p><b>Source</b> Tap to change the speaker modes - Wi-Fi / Bluetooth / Line-In</p>
	<p><b>Volume</b> Press to adjust the volume up or down. You can also ask Alexa to set the volume level by saying, "Alexa, set volume to..." and insert the volume level you want the speaker set to. Example: If you say "Alexa, set the volume to 5" Alexa will increase or decrease the volume level to 50% of maximum volume.</p>

	<p><b>Connect the JAS-725 to Wi-Fi Network link up again.</b> In Wi-Fi Mode, press and hold this button once to link up the JAS-725 with your Wi-Fi network. Follow the instructions on the Jensen Wi-Fi Audio App.</p>
	<p><b>Play/Pause</b> Tap to play or pause audio playing from the JENSEN Wi-Fi Audio app or from a Bluetooth connected device.</p> <p><b>Bluetooth Pair</b> Press and hold to connect to a new Bluetooth device.</p> <p><b>Answer / End Call</b> Tap the button to answer an incoming call. Tap the button again to end the call.</p>
	<p><b>Alexa Mic ON/OFF AND TAP TO TALK</b> Tap the Tap to Talk button to activate Amazon Alexa and say a command. You can also just say, "Alexa..", within range of the speaker's microphones. Tap the Mic On/Off button to mute the microphones and disable Amazon Alexa.</p> <p>In Wi-Fi mode, press and hold this button for 10 seconds until display changed to 12:00 then release it, unit will reset Wi-Fi to factory setting then restart for set up.</p>
	<p><b>Light</b> Tap the button to turn on light ON / OFF</p> <p><b>Dimmer</b> Press and hold the button to change display dimmer settings - low and high.</p>

## ALEXA MODE INDICATION

Flashing White	Wi-Fi is disconnected
Light Off	Wi-Fi is Connected
Solid Turquoise	Alexa is listening
Solid Blue	Alexa is thinking
Turquoise and Blue changing	Alexa is talking
Solid Red	The microphones are muted
Flashing Amber	The JAS-725 is not logged into your Alexa account (follow the voice instructions for connecting)

## GETTING STARTED

### CONNECTING THE AC POWER

This unit operates using the included AC adaptor with 5V  $\ominus \text{---} \oplus$  1.5A (center-positive  $\ominus \text{---} \oplus$ ) output, and is compatible with standard 120V~ 60Hz AC household power. Insert the the DC Plug of the AC Adaptor into the DC IN jack on the back of the unit. Plug the AC Adaptor into a standard 120V~ 60Hz AC wall outlet.

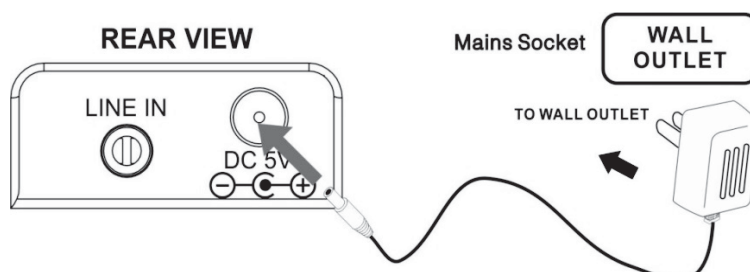

### CONNECTING THE JAS-725 TO A WI-FI NETWORK

#### IMPORTANT:

- The JAS-725 only operates on a single band (2.4 GHz) Wi-Fi network. If you are having problems connecting the JAS-725 to your network, check your router settings and make sure the 2.4 GHz signal is turned and you are accessing the correct band before proceeding.
- Before you begin, make sure you have an Amazon account. You need an Amazon account in order to use the Alexa voice control. Go to “[www.Amazon.com](http://www.Amazon.com)” to register.

#### Downloading the Alexa App

Download the Amazon Alexa app to your device by scanning the appropriate QR code below or by searching for the Amazon Alexa app in the Google Play™ Store, or Apple App Store®.



The Amazon Alexa app connects your speaker to Alexa’s voice services. It’s also where you see an overview of your requests and manage your contacts, lists, news, music and settings. Once downloaded, open the Alexa app and log into your Amazon account. If you do not already have an Amazon account, choose “Create a new Amazon account” and enter the requested info. Once logged in, the app will prompt you for setup. You can add these details now by choosing “Get Started,” or skip these steps and complete the process later. You cannot use Alexa Voice Services if you are not logged into an Amazon account.



## **Downloading the JENSEN Wi-Fi Audio App**

Download the JENSEN Wi-Fi Audio App to your device by scanning the QR codes below or search for the Jensen Wi-Fi app in the Google Play™ Store, or Apple App Store®.

Android



Apple



The JENSEN Wi-Fi Audio app lets you play music and audio from streaming services like Spotify, Pandora or others. It also controls the speaker's other functions, such as Multi-room play, Multi-channel play, etc.

**Note:** You may need to have a valid premium account to use some of the 3<sup>rd</sup> party streaming services available on the App.

## **Connecting to a Wi-Fi Network**

In order to use the Wi-Fi feature of the JAS-725, the unit and your mobile device must both be connected to the same Wi-Fi network. The JENSEN Wi-Fi Audio app will guide you through the process, just follow the on-screen instructions and have your network password ready.

After the initial connection, the speaker will remember the Wi-Fi network and automatically connect to it when it is in Wi-Fi Mode. If the speaker should become disconnected or will not connect normally, repeat the steps below.

## **Initial Wi-Fi Connection**

**Note:** If you have a dual band wireless router, be sure to connect to the 2.4GHz band and not the 5GHz band.

1. When you first power up the JAS-725, the ALEXA MODE / CONNECTION LED may flash multiple colors while powering up, this is normal. Please wait for the MODE / CONNECTION LED to turn white and begin flashing slowly. A short melody will play indicating the JAS-725 is in Wi-Fi Standby Mode.
2. Open the JENSEN Wi-Fi Audio App on your device and press "Search", then "Add Device (Image A, B, below).

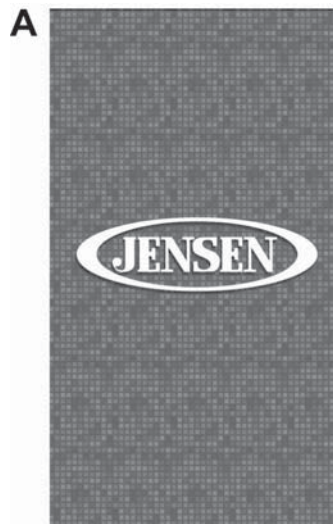

3. From the drop down menu, select the JAS-725 from the list and press “Next” (Image C, below).
4. The app will direct you to your mobile device’s Wi-Fi Settings Menu to connect directly to the JAS-725. Press “Settings” (Image D, below) to go to your mobile device’s Wi-Fi settings menu, then select JAS-725\_XXXX (Where XXXX is the last 4 digits of JAS-725 mac address) and return to the app when you are connected.

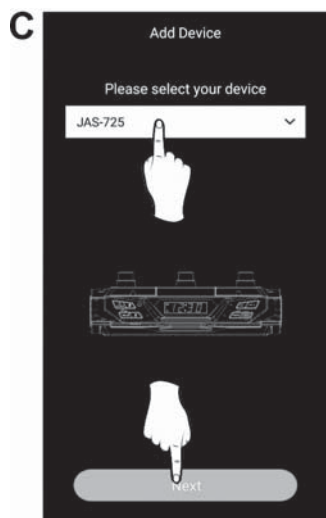

5. Once you have returned to the app, select your Wi-Fi network/router and enter your password, then touch the “Continue” button. This will connect your mobile device and the speaker to your Wi-Fi (Image E, below).
6. The app will display its progress as it configures the unit and your Wi-Fi network. When this is completed, a voice will announce the successful connection and the Mode/Connection LED will turn off. Touch the “Next” button to select the JAS-725 name from the list or you can set a custom name for the unit. (Image F, below).
7. Touch the “Finish” button on your smartphone screen to proceed to your Amazon Alexa account Set-up.

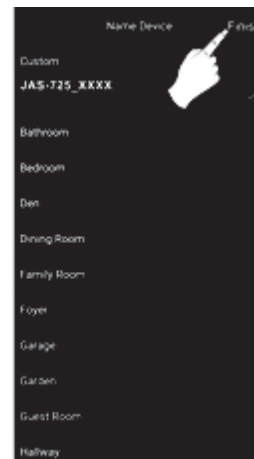
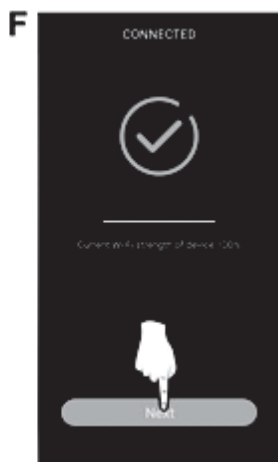

## Connecting to Your Amazon Account

1. When the JAS-725 Wi-Fi connection is completed, the app will prompt you to link the unit with the Amazon Alexa app on your device (Image G, below). If you do not have the Amazon Alexa app on your device, refer to the instructions in the “**Downloading the Alexa App**” section of the manual.

**NOTE:** If you do not want to login to your Amazon account and link Alexa to the unit at this time, press “Cancel”. You can complete it later by following the steps on the following page.

2. Enter your Amazon account information to complete setup and begin using Amazon Alexa with your unit (Image H, below).

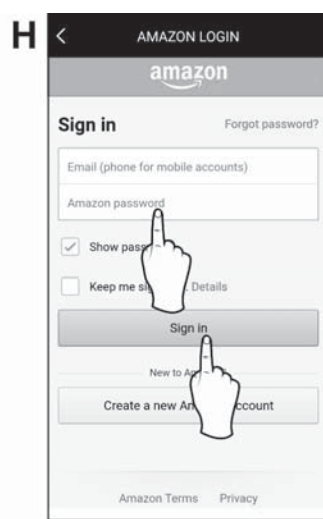
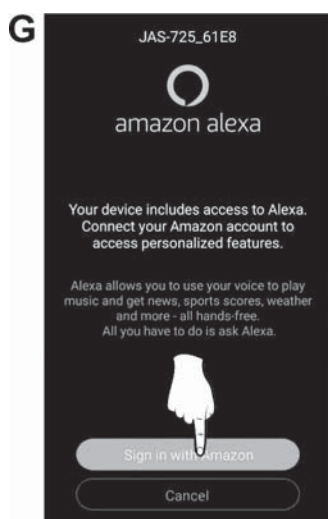

3. Follow the instructions on your smartphone’s screen.
4. After finishing the Amazon account set-up, the app will prompt you to change your smartphone’s Wi-Fi setting to your Wi-Fi network. Touch the “Wi-Fi Setting” button on your smartphone’s screen and select the same Wi-Fi network that your JAS-725 is connected to.

- Return to JENSEN Wi-Fi Audio App, you will see the JAS-725 now appears on the “DEVICE LIST” screen.

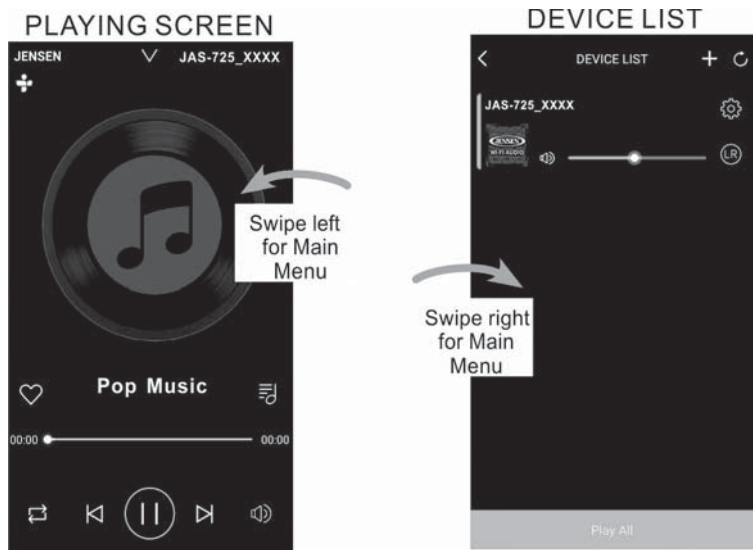

- To add more speakers touch the “+” icon in the top right corner of your smartphone screen and repeat the above steps.

## Amazon Alexa Manual Setup

- From the Music Player Screen (Image I, below), swipe right to access the Main Menu.
- Select Amazon Alexa from the list (Image J, below).
- Sign into your Amazon account when prompted.

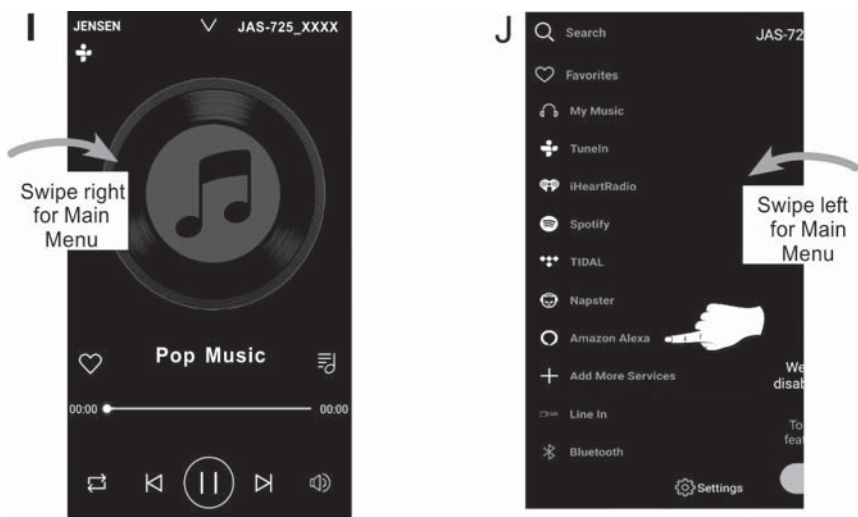

## Clock Display

After setting-up the JAS-725 on your Wi-Fi network, and successfully logging into your Amazon account, the internal clock will automatically synchronize with your local network time and will show on the display.

### Notes:

- In order to have correct clock displaying, make sure the smartphone used when

setting up the JAS-725 is set to automatically update the time and time zone using your local network time.

- 2.) To reset the clock, press and hold the Mic On/Off button for 10 second to completely reset the unit, follow steps mentioned in “**Reset JAS-725 WiFi to Factory Default Settings**” section below to setup the unit again.

### **Reconnecting the JAS-725 to a Wi-Fi network**

1. Turn on the unit and select Wi-Fi mode, press and hold the WPS button on the front panel of JAS-725. You will hear the “Internet setup mode, follow the instructions in the app to finish the setup” voice prompt.
2. Follow the steps in “**Initial Wi-Fi Connection**” section of the manual.

### **Resetting the JAS-725 Wi-Fi to Factory Default Settings**

1. Turn on the unit and select Wi-Fi mode, press and hold the WPS button for 10 seconds and release the button. You will hear the “Restore to factory setting” voice prompt.
2. Wait for the unit to restart or until you the hear voice prompt for ready to set-up.
3. Follow the steps in “**Initial Wi-Fi Connection**” section of the manual.

**Note:** Always setup the Wi-Fi connection when the JAS-725 is ON and in Wi-Fi mode.

Pressing the WPS button in any other operation mode or in Standby mode may cause an error to occur.

## **USING THE AMAZON ALEXA VOICE CONTROL**

When asking Alexa questions always say “Alexa” first or tap the “Tap to talk” button on the front panel, Alexa Mode LED turns Turquoise, this indicate Alexa is listening.

Play music from Amazon Music, TuneIn and many more apps/ services just by using voice commands. Example: Say “*Alexa.... Play music from TuneIn Radio.*”

Answers questions, such as time and date, find out sports scores and schedules, read Audible audio books, listen to news, traffic and weather reports, find info on local businesses, consult Wikipedia Example: Say “*Alexa.... What time is it?*”

Take notes, prepare shopping lists, shop at Amazon.

**Note:** To enable voice control, you will need an account to play music from Amazon Music and some other services.

### **Things to Try with Alexa**

#### **Saying Command When Alexa Start**

Now that you are connected, try interacting with Alexa. Start by saying “Alexa,” or tap the Tap to talk button. When the ALEXA Mode LED turns to solid Turquoise, give Alexa a command or ask a question. Here are some examples:

- » “Alexa, tell me a joke.”
- » “Alexa, what’s in the news?”
- » “Alexa, what can you do?”

You can mute Alexa and disable the microphones by pressing the MIC ON/OFF button. The MIC indicator LED will change to red while the microphones are muted. In this mode, the speaker's audio will still work normally.

## Music Player Screen

This is the default screen when you open the JENSEN app.



1. Music Directory

2. The Speakers Name

3. Add to Favorites

4. Current Playlist

5. Repeat/Shuffle

6. Volume

7. Play/Pause Controls

8. MIC ON/OFF button

Swipe right for Main Menu

Swipe right for Device Menu

Pop Music

00:00 00:00

Play Source

- Music stored in your mobile device.
- Music from Alexa internet

## Main Menu Screen

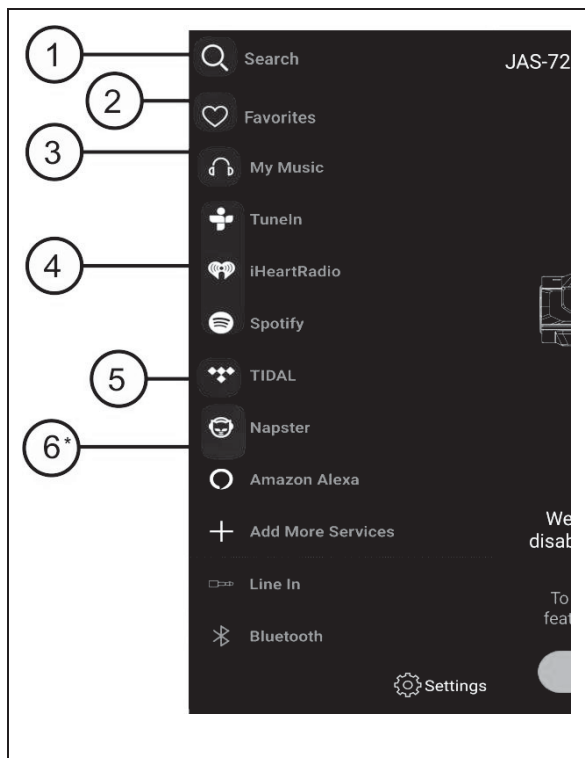

1. Search

2. Favorites

3. My Music

4. Internet Music Services

5. Add more Services

6\* Alternate Play Modes

JAS-72

Search

Favorites

My Music

TuneIn

iHeartRadio

Spotify

TIDAL

Napster

Amazon Alexa

Add More Services

Line In

Bluetooth

Settings

1. **Search**  
Search for songs, albums and artists.

2. **Favorites**  
Open songs, artists, albums, or stations that you have saved.

3. **My Music**  
Open music that is stored on your mobile device.

4. **Internet Music Services**  
Available third-party music apps.

5. **Add more Services**  
Press to add more third-party apps.

6. **Alternate Play Modes**  
Select Bluetooth/LINE-IN Mode.

## Device List Screen

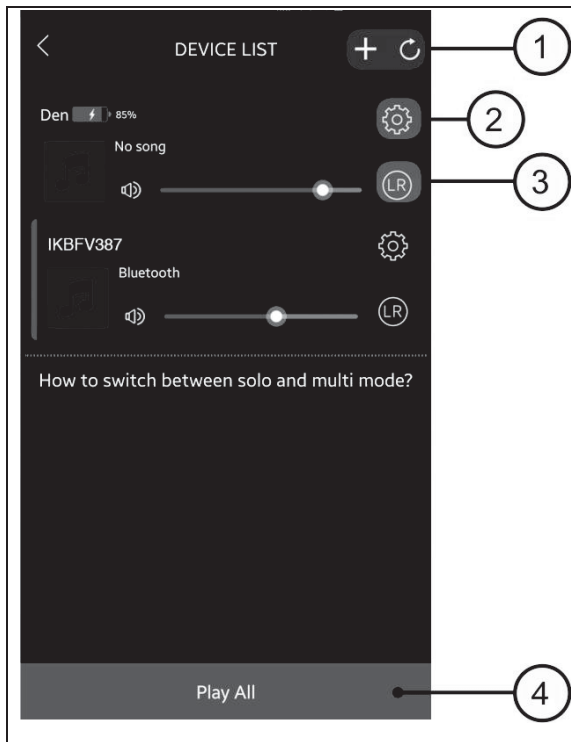

The screenshot shows the 'DEVICE LIST' screen. At the top right, there is a '+' icon and a refresh icon, labeled '1'. Below this is a settings gear icon, labeled '2'. The screen lists two devices: 'Den' (85% battery) and 'IKBFV387 Bluetooth'. Each device has a volume slider and an 'LR' channel selector icon, both labeled '3'. At the bottom, there is a 'Play All' button, labeled '4'. A dotted line separates the device list from a section titled 'How to switch between solo and multi mode?'.

- 1. Add Device/Refresh List**  
Add more speakers or refresh the list of available devices.
- 2. Speaker Settings**  
Rename a speaker, set preset stations, and find additional information on a speaker.
- 3. Audio Channel**  
Press to set audio channels for the speaker: L / R / LR (left/right/stereo).
- 4. Play All**  
Play music on all connected speakers.

## GROUP AND UNGROUP THE SPEAKERS

### Multi-room Play

Place speakers in any room and use the app to play music from the speaker of your choice. You can play different songs from different speakers, set individual volume levels, or you can link all of the speakers to play the same song.

### Multi-mode

In the Device List, press and hold a device icon for two seconds, then drag towards another device to link the speakers together.

#### Note:

- 1.) Synchronized playback only works in Wi-Fi mode.
- 2.) Only the Master speaker in the group will have the Alexa Voice feature.

### Solo-mode

Press and hold the device icon, then drag downwards past the dotted line.

#### Multi-channel Play with Multiple Speakers

You can use two or more speakers in one room for a surround sound effect by setting the Audio Channel selector to "LR" (stereo) for all of the speakers.

You can also use two speakers at once for stereo play by setting the Audio Channel selector to "L" and "R" for the "left" and "right" speaker respectively.

## PLAYBACK MUSIC ON THE SPEAKERS

### Internet Music Services

The JENSEN Wi-Fi Audio App supports and can play songs from Spotify, Pandora, or others. Similar to the setup process for Alexa, some of these third-party services will prompt you to log in and link your account with the JENSEN Wi-Fi Audio App so that it can access media you already have saved with that service.

- Select your local songs through MY MUSIC.
- Access Web Radio through TuneIn.
- Change Input through Bluetooth or Line In.
- Search for online songs through Search.
- Access your Favorite songs through Favorites.
- Access Web services by touching the corresponding icons.

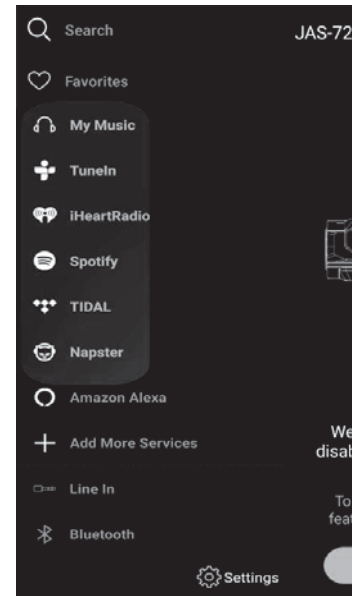



## BLUETOOTH OPERATION



### PAIRING (LINKING) A BLUETOOTH ENABLED CELL PHONE OR OTHER BLUETOOTH ENABLED DEVICE to the JAS-725

1. With the JAS-725 in power ON Mode, tap the SOURCE button to select Bluetooth mode. The Bluetooth Indicator  LED lights and flashing. The JAS-725 is now ready to pair (link) with your Bluetooth device.
2. Turn on the Bluetooth feature of your cell phone. Enable the search or scan feature to find the JAS-725.

**Note:** If you have more than one JAS-725 within range, make sure you are connecting to the appropriate speaker.

3. Select "JAS-725" from the device list when it appears on your device screen. If required, enter the pass code "0000" to pair (link) the JAS-725 with your cell phone.
4. After successfully pairing (linking) your cell phone with the JAS-725, the Bluetooth Mode Indicator  LED stops flashing and remains lit. You can now play music from your cell phone or Bluetooth device wirelessly to the JAS-725.

**Note:** If you want to connect the JAS-725 to another cell phone after pairing successfully, then you need to turn off the Bluetooth on the paired cell phone first if it is in range before going through the above steps. Otherwise, the JAS-725 will automatically reconnect to the previously linked cell phone or device. Then press and hold the Bluetooth  /PLAY/PAUSE  button to put the JAS-725 into Bluetooth pairing mode, the LED Indicator will be flashing Turquoise.

5. Press the VOLUME +/- button to adjust the volume level.
6. Press the PLAY/PAUSE  button to pause or resume playback.
7. To turn off the JAS-725 Bluetooth, press and hold the  button on main unit for 2





seconds to turn the unit to standby mode. Mode Indicator LED turns off. Don't forget to also turn off the Bluetooth feature on your cell phone or Bluetooth device.

**Notes:**

- 1.) Refer to manual of your cell phone or other Bluetooth enabled device for Bluetooth operation, since it may vary from model to model.
- 2.) If your Bluetooth enabled device does not support A2DP, it will not play the music through the speaker, even after it's paired (linked).
- 3.) If you are pairing (linking) your computer to the JAS-725 using Bluetooth, you may need to set the JAS-725 as your computer's default sound device.

**Re-linking to a cell phone or Bluetooth device**

If your cell phone or Bluetooth device is already paired with the JAS-725, but became unlinked at some point, even with both Bluetooth devices turned on. You can re-link them by:

1. Press and hold the  /PLAY/PAUSE button to re-link your cell phone. The  Indicator LED will turn on and flash while linking.
2. Select the JAS-725 from the devices list on your cell phone for linking. The  Indicator LED stops flashing and remains lit if the JAS-725 and your cell phone have been re-linked successfully.
3. You can also re-link the JAS-725 by using Bluetooth operation of your cell phone. Please refer to operation manual of your cell phone for more information.

**ANSWER THE INCOMING CALL**

When your unit playing mobile music by Bluetooth and receiving an incoming call on your mobile phone, the music will be stop and ring sound from your mobile phone. Tap the PLAY/PAUSE  button to answer the call. Tap the button again to end the call, the music will sound again (or press the PLAY button to play again).

**LINE-IN OPERATION**

This unit provides a LINE IN jack for connecting external audio devices like MP3 players, CD players and listen to them through the speakers of this unit.

1. Use an audio cable (included) with one 3.5 mm stereo plug on each end of the cable.
2. To select auxiliary audio input, plug one end into the Aux IN jack on the back of main unit.
3. Plug the other end of the cable into the Line-out Jack or Headphone Jack of your external audio device.
4. Turn on the external audio device and tap the  button to turn on the main unit.
5. Tap the MODE button to select LINE IN mode, LINE IN indicator LED turns on.
6. The volume level can now be controlled through the main unit. Operate all other functions on the auxiliary device as usual.

**NOTE:**

- If you connect this unit to the Line-Out Jack of your external device then you only need to adjust the volume control of this unit. If you connected the Headphone Jack of your external device then you may need to adjust both the volume control of your external device and the volume control of this unit to find the most desirable volume setting.
- Press and hold the POWER  button for 2 seconds to turning off the unit when you finish listening. Don't forget to switch off the power of your external device as well.

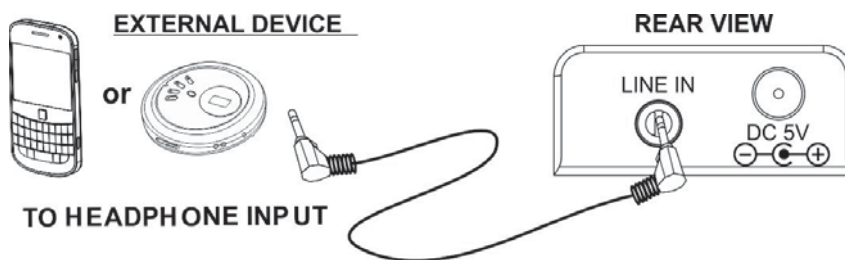

## RESETTING THE JAS-725

In case of malfunction due to electrostatic discharge, the apparatus has to be reset by disconnecting it from mains supply. Unplug the AC adaptor from main power, wait at least for 60 seconds before reconnect the AC adaptor power.

## CARE AND MAINTENANCE

1. Do not subject the unit to excessive force, shock, dust or extreme temperature.
2. Do not tamper the internal components of the unit.
3. Clean your unit with a dry cloth. Solvent or detergent should never be used.
4. Avoid leaving your unit in direct sunlight or in hot, humid or dusty places.
5. Keep your unit away from heating appliances and sources of electrical noise such as fluorescent lamps or motors.

### CLEANING THE UNIT

- To prevent fire or shock hazard, disconnect your unit from the AC power source when cleaning.
- The finish on the unit may be cleaned with a dust cloth and cared for as other furniture, Use caution when cleaning and wiping the plastic parts.
- If the cabinet becomes dusty wipe it with a soft dry dust cloth. Do not use any wax or polish sprays on the cabinet.
- If the front panel becomes dirty or smudged with fingerprints it may be cleaned with a soft cloth slightly dampened with a mild soap and water solution. Never use abrasive cloths or polishes, as these will damage the finish of your unit.

**CAUTION:** Never allow any water or other liquids to get inside the unit while cleaning.

**Note:** This unit is not magnetically shielded and may cause color distortion on the screen of some TVs or video monitors. To avoid this, you may need to move the unit further away from the TV or monitor if unnatural color shifts or image distortion occurs.

## TROUBLESHOOTING GUIDE

Should you experience difficulties in the use of this player please refer to the following chart or call 1-800-777-5331 for Product Service and Support.

Symptom	Possible Problem	Solution
The unit does not respond (no power)	The unit is disconnected from the AC outlet.	Reconnect to the AC outlet.
	The AC outlet has not power.	Try the unit on another outlet.
Unit is ON but there is low or no volume	The volume control has been turned all the way down.	Turn the Volume control to a higher output.
Cannot connect to a Wi-Fi network	Speaker is off or not in Wi-Fi mode.	Turn on the speaker and select Wi-Fi mode.
	The Wi-Fi network password is incorrect or the network is not working.	Select the correct Wi-fi network from your available options, or try your other device to ensure your Wi-Fi network is working properly.
	The JENSEN Wi-Fi Audio App is not installed properly	Uninstall then reinstall the App, turn the speaker power Off, and then On again.
No Sound	The JAS-725 is not on same Wi-Fi network as your smartphone.	Restart the setup using the WPS button. Use the same WiFi network for speaker & your smartphone.
	Speaker is not set-up properly.	Set-up the speaker by following the set-up steps in the manual.
	You have not selected casting to the JAS-725.	Select the JAS-725 from your smartphone screen.
	The JAS-725 is not connected via Bluetooth with your cell phone.	Go through "Bluetooth set-up Operations" process to link to the JAS-725.
	Speaker placement out of Bluetooth range.	Relocate the speaker within Bluetooth operating range (33 ft.)
Alexa voice control not function.	The JAS-725 is not connected to your WiFi network.	Use Jensen app to connect JAS-725 to your Wi-Fi network.
	You have not logged into your Amazon Alexa account.	Create or login to your Amazon Alexa account.
	The JAS-725 microphones are muted	Tap the MIC ON/OFF button to enable the microphones.
Sound is distorted	Volume level is set too high.	Decrease the volume.
	Sound source is distorted.	If the external device original sound source is of poor quality, distortion and noise are easily noticed with high-power speakers. Try a different audio source such as a music CD. If you are using an external sound source like older generation of iPod, try reducing the output volume on the device itself. Also try turning bass boost OFF or change the EQ setting.
Unit gets warm after extended play at high volume	This is normal.	Turn the unit off for a period of time or lower volume.

## SPECIFICATION

### Power requirement:

Main Unit

AC-DC Adaptor DC 5V, 1.2A ⊖ ⊕



At Spectra, environmental and social responsibility is a core value of our business. We are dedicated to continuous implementation of responsible initiatives with an aim to conserve and maintain the environment through responsible recycling.

Please visit us at <http://www.spectraintl.com/green.htm> for more information on Spectra's green initiatives or to find a recycler in your area.

The *Bluetooth*<sup>®</sup> word mark and logos are registered trademarks owned by Bluetooth SIG, Inc. and any use of such marks by Spectra Merchandising Intl, Inc. is under license. Other trademarks and trade names are those of their respective owners.

Amazon, Alexa, and all related logos and motion marks are trademarks of Amazon.com, Inc. or its affiliates.

### Amazon Terms & Policies

The JAS-725 is an Alexa- enabled device. Before using this speaker, please read all rules and policies for Alexa, including the Amazon.com Privacy Notice at [www.amazon.com/privacy](http://www.amazon.com/privacy) and the terms found in the Alexa App in Help > legal & Compliance. These terms, notices, and policies are, collectively, the "Agreements" By using Alexa, you agree to be bound by the Agreements.

## 90 DAY LIMITED WARRANTY AND SERVICE VALID IN THE U.S.A. ONLY

SPECTRA MERCHANDISING INTERNATIONAL, INC. warrants this unit to be free from defective materials or factory workmanship for a period of 90 days from the date of original customer purchase and provided the product is utilized within the U.S.A. This warranty is not assignable or transferable. Our obligation under this warranty is the repair or replacement of the defective unit or any part thereof, except batteries, when it is returned to the SPECTRA Service Department, accompanied by proof of the date of original consumer purchase, such as a duplicate copy of a sales receipt.

You must pay all shipping charges required to ship the product to SPECTRA for warranty service. If the product is repaired or replaced under warranty, the return charges will be at SPECTRA's expense. There are no other express warranties other than those stated herein. This warranty is valid only in accordance with the conditions set forth below:

1. The warranty applies to the SPECTRA product only while:
  - a. It remains in the possession of the original purchaser and proof of purchase is demonstrated.
  - b. It has not been subjected to accident, misuse, abuse, improper service, usage outside the descriptions and warnings covered within the user manual or non-SPECTRA approved modifications.
  - c. Claims are made within the warranty period.

2. This warranty does not cover damage or equipment failure caused by electrical wiring not in compliance with electrical codes or SPECTRA user manual specifications, or failure to provide reasonable care and necessary maintenance as outlined in the user manual.
3. Warranty of all SPECTRA products applies to residential use only and is void when products are used in a nonresidential environment or installed outside the United States.

This warranty gives you specific legal rights, and you may also have other rights which vary from state to state. TO OBTAIN SERVICE please remove all batteries (if any) and pack the unit carefully and send it freight prepaid to SPECTRA at the address shown below. IF THE UNIT IS RETURNED WITHIN THE WARRANTY PERIOD shown above, please include a proof of purchase (dated cash register receipt) so that we may establish your eligibility for warranty service and repair of the unit without cost. Also include a note with a description explaining how the unit is defective. A customer service representative may need to contact you regarding the status of your repair, so please include your name, address, phone number and email address to expedite the process.

IF THE UNIT IS OUTSIDE THE WARRANTY PERIOD, please include a check for **\$50.00** to cover the cost of repair, handling and return postage. All out of warranty returns must be sent prepaid.

It is recommended that you contact SPECTRA first at 1-800-777-5331 or by email at [custserv@spectraintl.com](mailto:custserv@spectraintl.com) for updated information on the unit requiring service. In some cases the model you have may be discontinued, and SPECTRA reserves the right to offer alternative options for repair or replacement.

SPECTRA MERCHANDISING INTERNATIONAL, INC.  
4230 North Normandy Avenue,  
Chicago, IL 60634, USA.  
1-800-777-5331

To register your product, visit the link on the website below to enter your information.  
<http://www.spectraintl.com/wform.htm>

0818

Printed in China