

# DIGITAL PROPORTIONAL SYSTEM

## 2.4GHZ MT 600

### Transmitter MT 600 Operating Instructions

#### System Specifications

Model: **MT 600**

Output Power: <100mW

Operating Voltage: 4.8 or 6V

Power Supply: 4 Cell Alkaline/Ni-Cd/Ni-MH

Frequency/Modulation Type: 2.4GHz FHSS

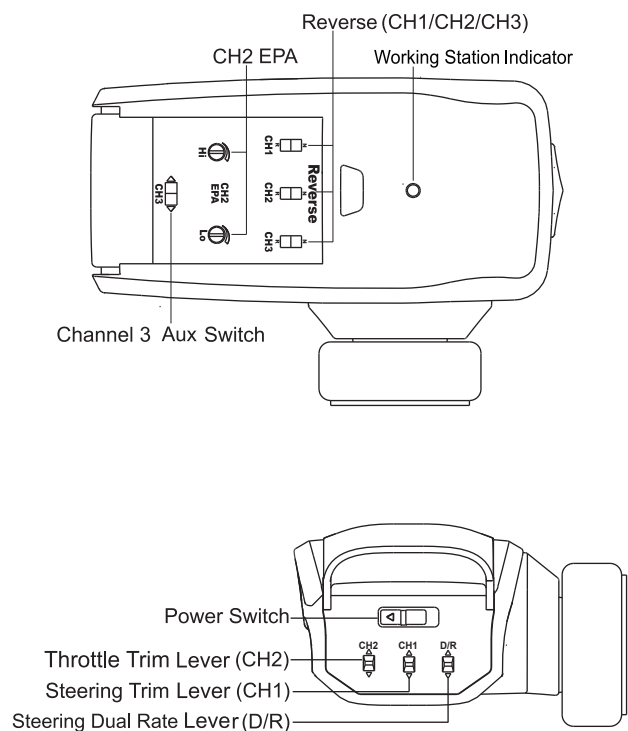
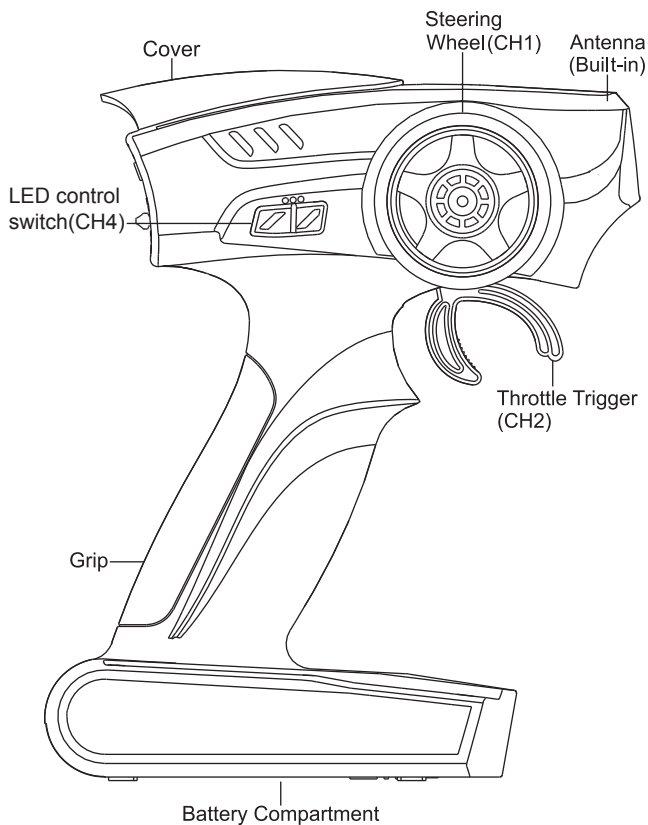

#### Installing the Transmitter Batteries



Open the battery holding tray. Insert 4 AA batteries into the marked spaces. Please note the correct direction of the batteries.

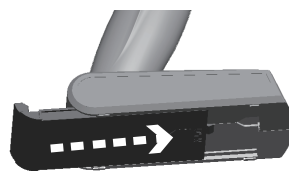

Incorrect battery insertion could damage the transmitter. This 2.4Ghz transmitter has an internal Antenna.

#### Installing the battery pack



You need to insert the battery pack in the open section for the battery. Use the chassis cut-out for corner wiring if needed. Use the straps provided to secure the battery in place.

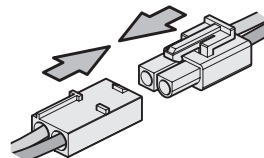

Once fastened and secured please connect the battery plug into the speed controller plug noting correct polarity. Red to red, black to black.

## CH1(Steering) Trim

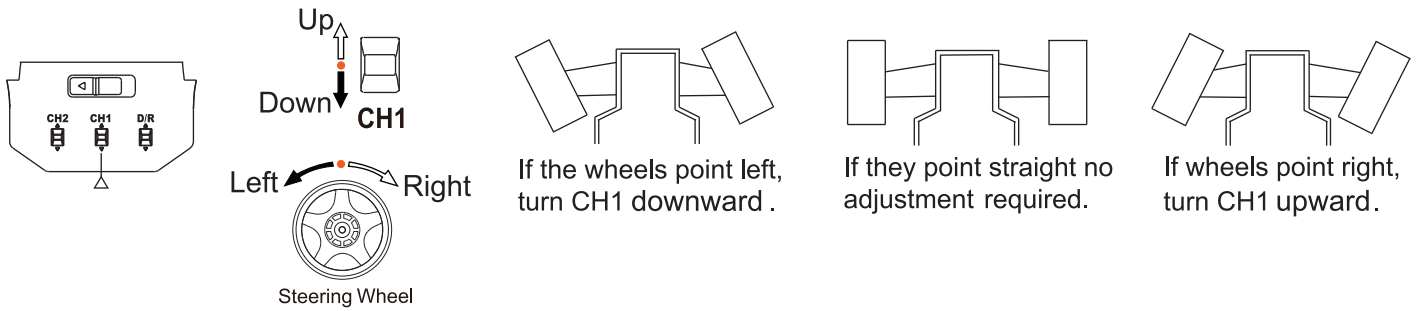

## CH1(Steering Dual-Rate)D/R

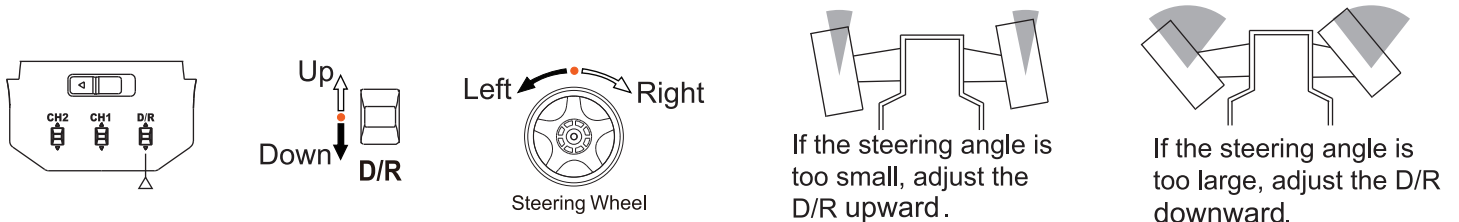

## CH2(Throttle) Trim

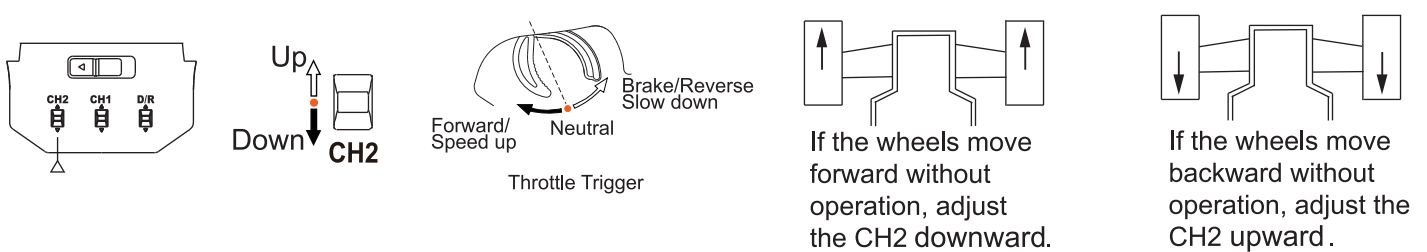

## CH1(Steering Reverse)

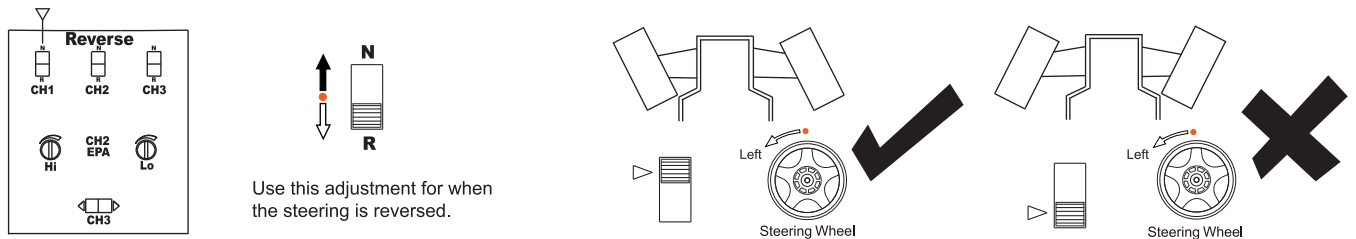

## CH2(Throttle Reverse)

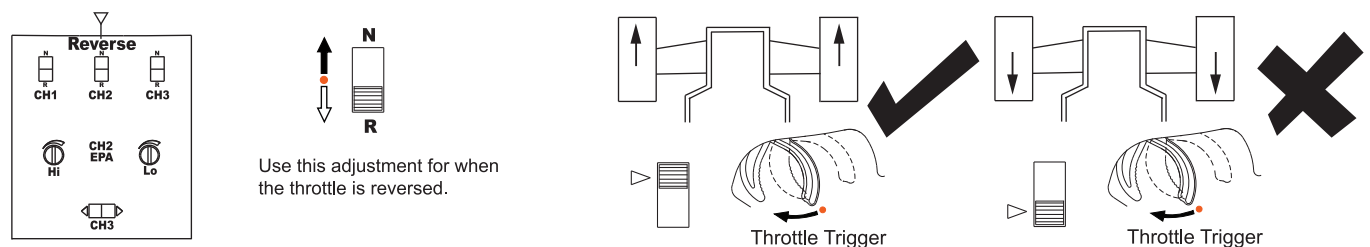

## CH2(Throttle end point)

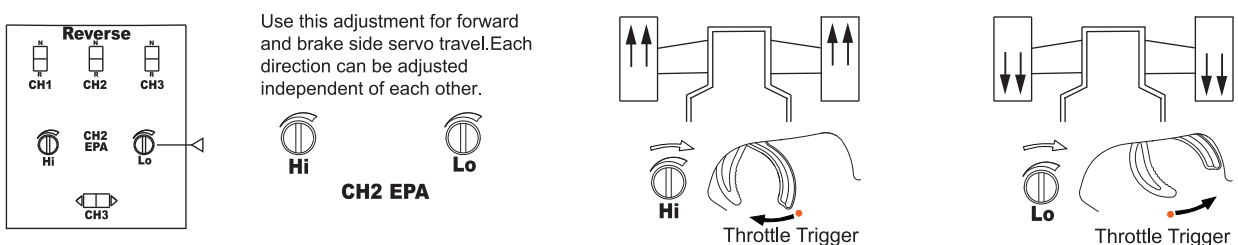

# Receiver MT206RE Operating Instructions

## System Specifications

Model: **MT206RE**

Frequency: 2.4GHz FHSS

Operating Voltage: 6.0~8.4V (Alkaline/Ni-Cd/Ni-MH)  
7.4~11.1V (Li-poly3S)

Fail Safe: Yes (All Channels)

### Mechanical Speed Control Setup

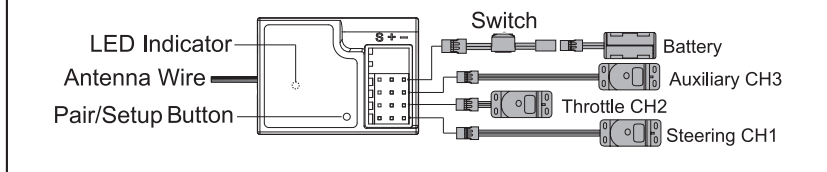

### Electronic Speed Control Setup

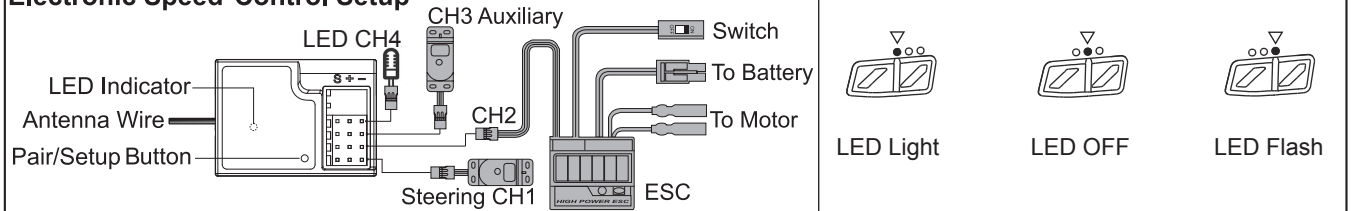

## MT600 & MT206RE Bind

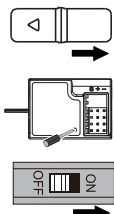

Power off the transmitter. Press and hold the binding button on the receiver, in the meantime, turn the receiver on, the LED flashes quickly. Loosen the button.

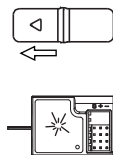

Turn the transmitter on, it will bind with the receiver automatically. If the LED indicator on the receiver becomes and stays continuously lit, the binding is successfully setup.

**!** The receiver can only receive the signals transmitted by the transmitter once they are in successfully binding. Generally the two of them have been paired before leaving the factory, please check before use. If not, users can setup the binding according to the following steps.

**!** If the LED light is flashing or OFF, the setup failed. Please shorten the distance between the transmitter and the receiver, bind again. Long binding distance can cause setup failure, so please do not keep the receiver far away from the transmitter.

## Fail-Safe setup procedure

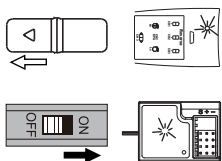

Turn on the power switches of both the transmitter and receiver, the LED indicator lights should both be on.

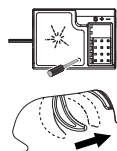

Press and hold the receiver setup button for 2 seconds, the LED rapid flash, in 5 seconds, put CH2 in the brake condition and hold it until the LED continuously lit.

**!** Please note transmitter must be paired with receiver before setting up the S/F mode. The model car has been preset at a F/S mode to be automatically braked after running out of control. Check before use whether the the F/S mode still works. If not, follow these steps to reset.

**!** Any new binding of the transmitter and receiver should clear the preset fail-safe.

# Receiver MT206RE Operating Instructions

## System Specifications

Model: **MT206RE**

Frequency: 2.4GHz FHSS

Operating Voltage: 6.0~8.4V (Alkaline/Ni-Cd/Ni-MH)  
3.7~7.4V (Li-poly2S)

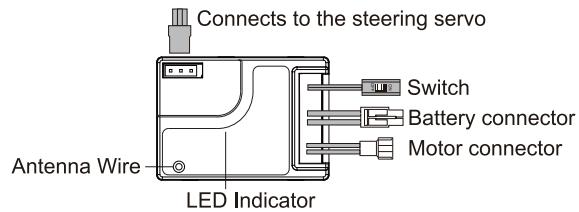

## MT600 & MT206RE Bind

**Step 1: Power off both transmitter and receiver.**

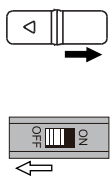

**Step 2: Turn on receiver.**

The LED indicator on the receiver will begin to flash.

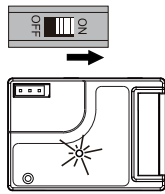

**Step 3: Turn on the transmitter.**

The transmitter and receiver will now bind automatically within the next 2 seconds.

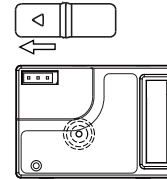

Once the receiver LED stays lit the binding is complete.

## Transmitter & Receiver LED Display

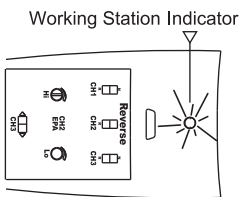

**LED ON:** Connected  
**Rapid Flash:** The signal is interrupted  
**Slow Flash:** Low-voltage warning  
**LED OFF:** Power off

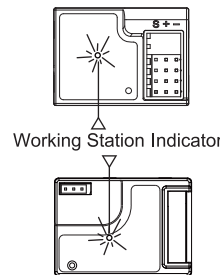

**LED ON:** Connected  
**Rapid Flash:** The signal is interrupted  
**Slow Flash:** Low-voltage warning  
**LED OFF:** Power off

## Receiver's Antenna Installation

The wave length of the 2.4GHz is much shorter than that of the conventional frequencies, it is very susceptible to loss of signal which results in a receiving error.

To obtain the best results, please refer to the following instructions;

1. The antenna must be kept as straight as possible. Otherwise it will reduce the effective range.
2. The antenna should be perpendicular to the model. Larger models can have large metal objects that can attenuate the RF signal. In this case the antennas should be placed at sides of the model. Then the best RF signal condition is obtained at any attitude.
3. The antennas must be kept away from conductive materials, such as metal and carbon by at least a half inch. The coaxial part of the antennas does not need to follow these guidelines, but do not bend it in a small radius.
4. Keep the antennas away from the motor, ESC, and other noise sources as much as possible.

\*The main purpose of the photo demonstrates how the antenna should be placed. For actual installation the receiver must be wrapped with a sponge or placed with floating material to protect it from vibration.

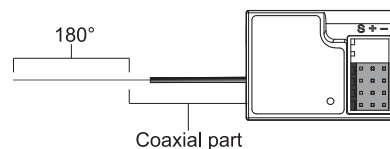

The receiver contains precision electronic parts. It is the most delicate radio component on-board the model and should be protected from vibration, shock and temperature extremes. To protect the receiver, wrap it in R/C foam rubber or other vibration-absorbing material. If appropriate, waterproof the receiver by placing it in a plastic bag and closing the open end with a rubber band before wrapping it in foam. If moisture enters the receiver, intermittent operation or a failure may result. Wrapping the receiver in a plastic bag also protects it from fuel and exhaust residue which, in some models, can work its way into the model.

**FCC Caution:**

This device complies with part 15 of the FCC Rules. Operation is subject to the following two conditions: (1) This device may not cause harmful interference, and (2) this device must accept any interference received, including interference that may cause undesired operation.

Any Changes or modifications not expressly approved by the party responsible for compliance could void the user's authority to operate the equipment.

**Note:** This equipment has been tested and found to comply with the limits for a Class B digital device, pursuant to part 15 of the FCC Rules. These limits are designed to provide reasonable protection against harmful interference in a residential installation. This equipment generates uses and can radiate radio frequency energy and, if not installed and used in accordance with the instructions, may cause harmful interference to radio communications. However, there is no guarantee that interference will not occur in a particular installation. If this equipment does cause harmful interference to radio or television reception, which can be determined by turning the equipment off and on, the user is encouraged to try to correct the interference by one or more of the following measures:

- Reorient or relocate the receiving antenna.
- Increase the separation between the equipment and receiver.
- Connect the equipment into an outlet on a circuit different from that to which the receiver is connected.
- Consult the dealer or an experienced radio/TV technician for help.

The device has been evaluated to meet general RF exposure requirement. The device can be used in portable exposure condition without restriction.