



**CFR 47 FCC PART 15 SUBPART E
CERTIFICATION TEST REPORT**

For

DJI High-Bright Remote Monitor

MODEL NUMBER: RXD2

FCC ID: 2ANDR-RXD2202109

REPORT NUMBER: 4789980498.1-2-7

ISSUE DATE: October 18,2021

Prepared for

**SZ DJI Osmo Technology Co.,Ltd.
4F, Jingkou Community Comprehensive Service Building, No. 83 Bishui Road
North, Guangming Street, Guangming District, Shenzhen**

Prepared by

**UL Verification Services (Guangzhou) Co., Ltd, Song Shan Lake Branch
Building 10, Innovation Technology Park, No. 1, Li Bin Road, Song Shan Lake Hi-
Tech Development Zone Dongguan, 523808, People's Republic of China**

Tel: +86 769 22038881

Fax: +86 769 33244054

Website: www.ul.com



Revision History

<u>Rev.</u>	<u>Issue Date</u>	<u>Revisions</u>	<u>Revised By</u>
V0	07/15/2021	Initial Issue	Mick Zhang
V1	08/20/2021	Update product name to "DJI High-Bright Remote Monitor" Updated modulation to OFDM (QPSK, 16QAM, 64QAM)	Mick Zhang
V2	10/15/2021	Update ISED frequency range for use by deleting 5150-5250MHz	Mick Zhang
V3	10/18/2021	Divide the report into FCC and ISED	Mick Zhang



Summary of Test Results			
Clause	Test Items	FCC Rules	Test Results
1	6dB/26dB Bandwidth	FCC 15.407 (a)&(e)	PASS
2	99% Occupied Bandwidth	RSS-Gen Clause 6.7	PASS
3	Conducted Output Power	FCC 15.407 (a)	PASS
4	Power Spectral Density	FCC 15.407 (a)	PASS
5	Radiated Bandedge and Spurious Emission	FCC 15.407 (b) FCC 15.209 FCC 15.205	PASS
6	Conducted Emission Test for AC Power Port	FCC 15.207	PASS
7	Frequency Stability	FCC 15.407 (g)	PASS
8	Antenna Requirement	FCC 15.203	PASS
Note: 1.This test report is only published to and used by the applicant, and it is not for evidence purpose in China. 2. The measurement result for the sample received is <Pass> according to < CFR 47 FCC PART 15 SUBPART C > when <Accuracy Method> decision rule is applied.			



TABLE OF CONTENTS

1. ATTESTATION OF TEST RESULTS	7
2. TEST METHODOLOGY	8
3. FACILITIES AND ACCREDITATION	8
4. CALIBRATION AND UNCERTAINTY	9
4.1. <i>MEASURING INSTRUMENT CALIBRATION</i>	9
4.2. <i>MEASUREMENT UNCERTAINTY</i>	9
5. EQUIPMENT UNDER TEST	10
5.1. <i>DESCRIPTION OF EUT</i>	10
5.2. <i>MAXIMUM OUTPUT POWER</i>	10
5.3. <i>CHANNEL LIST</i>	11
5.4. <i>DESCRIPTION OF AVAILABLE ANTENNAS</i>	15
5.5. <i>THE WORSE CASE POWER SETTING PARAMETER</i>	16
5.6. <i>THE WORSE CASE CONFIGURATIONS</i>	16
5.7. <i>DESCRIPTION OF TEST SETUP</i>	17
6. MEASURING INSTRUMENT AND SOFTWARE USED	18
7. ANTENNA PORT TEST RESULTS	20
7.1. <i>ON TIME AND DUTY CYCLE</i>	20
7.2. <i>6/26 dB EMISSION BANDWIDTH AND 99 % OCCUPIED BANDWIDTH</i>	21
7.3. <i>CONDUCTED OUTPUT POWER</i>	23
7.4. <i>POWER SPECTRAL DENSITY</i>	26
8. RADIATED TEST RESULTS	28
8.1. <i>RESTRICTED BANDEDGE</i>	34
8.1.1. <i>5G SRD 1.4MHz MODE</i>	34
UNII-3 BAND	34
8.1.2. <i>5G SRD 1.4MHz CA MODE</i>	36
UNII-3 BAND	36
8.1.3. <i>5G SRD 3MHz MODE</i>	38
UNII-3 BAND	38
8.1.4. <i>5G SRD 3MHz CA MODE</i>	40
UNII-3 BAND	40
8.1.5. <i>5G SRD 10MHz MODE</i>	42
UNII-3 BAND	42
8.1.6. <i>5G SRD 20MHz MODE</i>	44
UNII-3 BAND	44
8.1.7. <i>5G SRD 40MHz MODE</i>	46
UNII-3 BAND	46



8.2.	SPURIOUS EMISSIONS (1 GHz ~ 7 GHz)	48
8.2.1.	5G SRD 1.4MHz MODE	48
	UNII-3 BAND	48
8.3.	SPURIOUS EMISSIONS (7 GHz ~ 18 GHz)	54
8.3.1.	5G SRD 1.4MHz MODE	54
	UNII-3 BAND	54
8.3.2.	5G SRD 1.4MHz CA MODE	60
	UNII-3 BAND	60
8.3.3.	5G SRD 3MHz MODE	66
	UNII-3 BAND	66
8.3.4.	5G SRD 3MHz CA MODE	72
	UNII-3 BAND	72
8.3.5.	5G SRD 10MHz MODE	78
	UNII-3 BAND	78
8.3.6.	5G SRD 20MHz MODE	84
	UNII-3 BAND	84
8.3.7.	5G SRD 40MHz MODE	90
	UNII-3 BAND	90
8.4.	SPURIOUS EMISSIONS (18 GHz ~ 26 GHz)	96
8.4.1.	5G SRD 1.4MHz MODE	96
8.5.	SPURIOUS EMISSIONS (26 GHz ~ 40 GHz)	98
8.5.1.	5G SRD 1.4MHz MODE	98
8.6.	SPURIOUS EMISSIONS (30 MHz ~ 1 GHz)	100
8.6.1.	5G SRD 1.4MHz MODE	100
8.7.	SPURIOUS EMISSIONS BELOW 30 MHz	102
8.7.1.	5G SRD 1.4MHz MODE	102
9.	AC POWER LINE CONDUCTED EMISSIONS	105
9.1.	5G SRD 1.4MHz MODE	106
10.	FREQUENCY STABILITY	108
11.	ANTENNA REQUIREMENTS	110
11.1.	Appendix A1: Occupied channel bandwidth	111
11.1.1.	Test Result	111
11.1.2.	Test Graphs	112
11.2.	Appendix A2: Min emission bandwidth	122
11.2.1.	Test Result	122
11.2.2.	Test Graphs	123
11.3.	Appendix B: Maximum conducted output power	133
11.3.1.	Test Result	133
11.4.	Appendix C: Maximum power spectral density	136
11.4.1.	Test Result	136
11.4.2.	Test Graphs	138
11.5.	Appendix D: Duty Cycle	152
11.5.1.	Test Result	152
11.5.2.	Test Graphs	153



11.6.	<i>Appendix E: Frequency Stability</i>	156
11.6.1.	Test Result.....	156



1. ATTESTATION OF TEST RESULTS

Applicant Information

Company Name: SZ DJI Osmo Technology Co.,Ltd.
Address: 4F, Jinkou Community Comprehensive Service Building, No. 83 Bishui Road North, Guangming Street, Guangming District, Shenzhen

Manufacturer Information

Company Name: SZ DJI Osmo Technology Co.,Ltd.
Address: 4F, Jinkou Community Comprehensive Service Building, No. 83 Bishui Road North, Guangming Street, Guangming District, Shenzhen

EUT Information

EUT Name: DJI High-Bright Remote Monitor
Model: RXD2
Brand: DJI
Sample Received Date: June 03, 2021
Sample Status: Normal
Sample ID: 3991066
Date of Tested: June 03, 2021 ~ July 15, 2021

APPLICABLE STANDARDS	
STANDARD	TEST RESULTS
CFR 47 FCC PART 15 SUBPART E	PASS

Prepared By:

Mick Zhang
Project Engineer

Check By:

Shawn Wen
Laboratory Leader

Approved By:

Stephen Guo
Laboratory Manager



2. TEST METHODOLOGY

The tests documented in this report were performed in accordance with ANSI C63.10-2013, CFR 47 FCC Part 2, CFR 47 FCC Part 15, KDB 789033 D02 v02r01, KDB414788 D01 Radiated Test Site v01 and KDB 662911 D01 Multiple Transmitter Output v02r01.

3. FACILITIES AND ACCREDITATION

Accreditation Certificate	<p>A2LA (Certificate No.: 4102.01) UL Verification Services (Guangzhou) Co., Ltd. Song Shan Lake Branch. has been assessed and proved to be in compliance with A2LA.</p> <p>FCC (FCC Designation No.: CN1187) UL Verification Services (Guangzhou) Co., Ltd. Song Shan Lake Branch. Has been recognized to perform compliance testing on equipment subject to the Commission's Declaration of Conformity (DoC) and Certification rules</p> <p>ISED (Company No.: 21320) UL Verification Services (Guangzhou) Co., Ltd. Song Shan Lake Branch. has been registered and fully described in a report filed with ISED. The Company Number is 21320 and the test lab Conformity Assessment Body Identifier (CABID) is CN0046.</p> <p>VCCI (Registration No.: G-20019, R-20004, C-20012 and T-20011) UL Verification Services (Guangzhou) Co., Ltd. Song Shan Lake Branch. has been assessed and proved to be in compliance with VCCI, the Membership No. is 3793. Facility Name: Chamber D, the VCCI registration No. is G-20019 and R-20004 Shielding Room B , the VCCI registration No. is C-20012 and T-20011</p>
---------------------------	---

Note 1: All tests measurement facilities use to collect the measurement data are located at Building 10, Innovation Technology Park, Song Shan Lake Hi tech Development Zone, Dongguan, 523808, China

Note 2: The test anechoic chamber in UL Verification Services (Guangzhou) Co., Ltd. Song Shan Lake Branch had been calibrated and compared to the open field sites and the test anechoic chamber is shown to be equivalent to or worst case from the open field site.

Note 3: For below 30 MHz, lab had performed measurements at test anechoic chamber and comparing to measurements obtained on an open field site. And these measurements below 30 MHz had been correlated to measurements performed on an OFS.



4. CALIBRATION AND UNCERTAINTY

4.1. MEASURING INSTRUMENT CALIBRATION

The measuring equipment utilized to perform the tests documented in this report has been calibrated in accordance with the manufacturer's recommendations and is traceable to recognize national standards.

4.2. MEASUREMENT UNCERTAINTY

Where relevant, the following measurement uncertainty levels have been estimated for tests performed on the apparatus:

Test Item	Uncertainty
Conduction emission	3.62 dB
Radiated Emission (Included Fundamental Emission) (9 kHz ~ 30 MHz)	2.2 dB
Radiated Emission (Included Fundamental Emission) (30 MHz ~ 1 GHz)	4.00 dB
Radiated Emission (Included Fundamental Emission) (1 GHz to 26 GHz)	5.78 dB (1 GHz ~ 18 GHz)
	5.23 dB (18 GHz ~ 26 GHz)
Duty Cycle	±0.028%
Emission Bandwidth and 99% Occupied Bandwidth	±0.0196%
Maximum Conducted Output Power	±0.766 dB
Maximum Power Spectral Density Level	±1.22 dB
Frequency Stability	±2.76%
Conducted Band-edge Compliance	±1.328 dB
Conducted Unwanted Emissions In Non-restricted Frequency Bands	±0.746 dB (9 kHz ~ 1 GHz)
	±1.328dB (1 GHz ~ 26 GHz)
Note: This uncertainty represents an expanded uncertainty expressed at approximately the 95% confidence level using a coverage factor of k=2.	



5. EQUIPMENT UNDER TEST

5.1. DESCRIPTION OF EUT

EUT Name	DJI High-Bright Remote Monitor
Model	RXD2
Radio Technology	SRD 5G
Operation frequency	UNII-1/UNII-2A/UNII-2C/UNII-3
Modulation	OFDM (QPSK,16QAM,64QAM)
Battery	DC 6.8V

Note: For UNII-1/UNII-2A/UNII-2C Bands, the EUT only support RX mode.

5.2. MAXIMUM OUTPUT POWER

UNII-3 BAND

SRD 5G	Frequency (MHz)	Max Power (dBm)
1.4M Mode	5725 ~ 5850	26.85
1.4M-CA Mode		26.87
3M Mode		26.96
3M-CA Mode		27.02
10M Mode		16.58
20M Mode		17.10
40M Mode		16.51

5.3. CHANNEL LIST

UNII-3 SRD 5G 1.4MHz Bandwidth (5726.5MHz-5846.5MHz)							
Channel	Frequency (MHz)	Channel	Frequency (MHz)	Channel	Frequency (MHz)	Channel	Frequency (MHz)
1	5726.5	17	5758.5	33	5790.5	49	5822.5
2	5728.5	18	5760.5	34	5792.5	50	5824.5
3	5730.5	19	5762.5	35	5794.5	51	5826.5
4	5732.5	20	5764.5	36	5796.5	52	5828.5
5	5734.5	21	5766.5	37	5798.5	53	5830.5
6	5736.5	22	5768.5	38	5800.5	54	5832.5
7	5738.5	23	5770.5	39	5802.5	55	5834.5
8	5740.5	24	5772.5	40	5804.5	56	5836.5
9	5742.5	25	5774.5	41	5806.5	57	5838.5
10	5744.5	26	5776.5	42	5808.5	58	5840.5
11	5746.5	27	5778.5	43	5810.5	59	5842.5
12	5748.5	28	5780.5	44	5812.5	60	5844.5
13	5750.5	29	5782.5	45	5814.5	61	5846.5
14	5752.5	30	5784.5	46	5816.5	/	/
15	5754.5	31	5786.5	47	5818.5	/	/
16	5756.5	32	5788.5	48	5820.5	/	/

UNII-3 SRD 5G 1.4MHz Bandwidth-CA Mode(5728.12MHz-5848.12MHz)							
Channel	Frequency (MHz)	Channel	Frequency (MHz)	Channel	Frequency (MHz)	Channel	Frequency (MHz)
1	5728.12	17	5760.12	33	5792.12	49	5824.12
2	5730.12	18	5762.12	34	5794.12	50	5826.12
3	5732.12	19	5764.12	35	5796.12	51	5828.12
4	5734.12	20	5766.12	36	5798.12	52	5830.12
5	5736.12	21	5768.12	37	5800.12	53	5832.12
6	5738.12	22	5770.12	38	5802.12	54	5834.12
7	5740.12	23	5772.12	39	5804.12	55	5836.12
8	5742.12	24	5774.12	40	5806.12	56	5838.12
9	5744.12	25	5776.12	41	5808.12	57	5840.12
10	5746.12	26	5778.12	42	5810.12	58	5842.12
11	5748.12	27	5780.12	43	5812.12	59	5844.12
12	5750.12	28	5782.12	44	5814.12	60	5846.12
13	5752.12	29	5784.12	45	5816.12	61	5848.12



14	5754.12	30	5786.12	46	5818.12	/	/
15	5756.12	31	5788.12	47	5820.12	/	/
16	5758.12	32	5790.12	48	5822.12	/	/
UNII-3 SRD 5G 3MHz Bandwidth Mode(5727.5MHz-5844.5MHz)							
Channel	Frequency (MHz)	Channel	Frequency (MHz)	Channel	Frequency (MHz)	Channel	Frequency (MHz)
1	5727.5	11	5757.5	21	5787.5	31	5817.5
2	5730.5	12	5760.5	22	5790.5	32	5820.5
3	5733.5	13	5763.5	23	5793.5	33	5823.5
4	5736.5	14	5766.5	24	5796.5	34	5826.5
5	5739.5	15	5769.5	25	5799.5	35	5829.5
6	5742.5	16	5772.5	26	5802.5	36	5832.5
7	5745.5	17	5775.5	27	5805.5	37	5835.5
8	5748.5	18	5778.5	28	5808.5	38	5838.5
9	5751.5	19	5781.5	29	5811.5	39	5841.5
10	5754.5	20	5784.5	30	5814.5	40	5844.5
UNII-3 SRD 5G 3MHz Bandwidth-CA Mode(5730.2MHz-5847.2MHz)							
Channel	Frequency (MHz)	Channel	Frequency (MHz)	Channel	Frequency (MHz)	Channel	Frequency (MHz)
1	5730.2	11	5760.2	21	5790.2	31	5820.2
2	5733.2	12	5763.2	22	5793.2	32	5823.2
3	5736.2	13	5766.2	23	5796.2	33	5826.2
4	5739.2	14	5769.2	24	5799.2	34	5829.2
5	5742.2	15	5772.2	25	5802.2	35	5832.2
6	5745.2	16	5775.2	26	5805.2	36	5835.2
7	5748.2	17	5778.2	27	5808.2	37	5838.2
8	5751.2	18	5781.2	28	5811.2	38	5841.2
9	5754.2	19	5784.2	29	5814.2	39	5844.2
10	5757.2	20	5787.2	30	5817.2	40	5847.2
UNII-3 SRD 5G 10MHz Bandwidth (5730.5MHz-5844.5MHz)							
Channel	Frequency (MHz)	Channel	Frequency (MHz)	Channel	Frequency (MHz)	Channel	Frequency (MHz)
1	5730.5	30	5759.5	59	5788.5	88	5817.5
2	5731.5	31	5760.5	60	5789.5	89	5818.5
3	5732.5	32	5761.5	61	5790.5	90	5819.5
4	5733.5	33	5762.5	62	5791.5	91	5820.5
5	5734.5	34	5763.5	63	5792.5	92	5821.5
6	5735.5	35	5764.5	64	5793.5	93	5822.5
7	5736.5	36	5765.5	65	5794.5	94	5823.5
8	5737.5	37	5766.5	66	5795.5	95	5824.5



9	5738.5	38	5767.5	67	5796.5	96	5825.5
10	5739.5	39	5768.5	68	5797.5	97	5826.5
11	5740.5	40	5769.5	69	5798.5	98	5827.5
12	5741.5	41	5770.5	70	5799.5	99	5828.5
13	5742.5	42	5771.5	71	5800.5	100	5829.5
14	5743.5	43	5772.5	72	5801.5	101	5830.5
15	5744.5	44	5773.5	73	5802.5	102	5831.5
16	5745.5	45	5774.5	74	5803.5	103	5832.5
17	5746.5	46	5775.5	75	5804.5	104	5833.5
18	5747.5	47	5776.5	76	5805.5	105	5834.5
19	5748.5	48	5777.5	77	5806.5	106	5835.5
20	5749.5	49	5778.5	78	5807.5	107	5836.5
21	5750.5	50	5779.5	79	5808.5	108	5837.5
22	5751.5	51	5780.5	80	5809.5	109	5838.5
23	5752.5	52	5781.5	81	5810.5	110	5839.5
24	5753.5	53	5782.5	82	5811.5	111	5840.5
25	5754.5	54	5783.5	83	5812.5	112	5841.5
26	5755.5	55	5784.5	84	5813.5	113	5842.5
27	5756.5	56	5785.5	85	5814.5	114	5843.5
28	5757.5	57	5786.5	86	5815.5	115	5844.5
29	5758.5	58	5787.5	87	5816.5	/	/

UNII-3 SRD 5G 20MHz Bandwidth (5735.5MHz-5839.5MHz)

Channel	Frequency (MHz)	Channel	Frequency (MHz)	Channel	Frequency (MHz)	Channel	Frequency (MHz)
1	5735.5	28	5762.5	55	5789.5	82	5816.5
2	5736.5	29	5763.5	56	5790.5	83	5817.5
3	5737.5	30	5764.5	57	5791.5	84	5818.5
4	5738.5	31	5765.5	58	5792.5	85	5819.5
5	5739.5	32	5766.5	59	5793.5	86	5820.5
6	5740.5	33	5767.5	60	5794.5	87	5821.5
7	5741.5	34	5768.5	61	5795.5	88	5822.5
8	5742.5	35	5769.5	62	5796.5	89	5823.5
9	5743.5	36	5770.5	63	5797.5	90	5824.5
10	5744.5	37	5771.5	64	5798.5	91	5825.5
11	5745.5	38	5772.5	65	5799.5	92	5826.5
12	5746.5	39	5773.5	66	5800.5	93	5827.5
13	5747.5	40	5774.5	67	5801.5	94	5828.5
14	5748.5	41	5775.5	68	5802.5	95	5829.5
15	5749.5	42	5776.5	69	5803.5	96	5830.5
16	5750.5	43	5777.5	70	5804.5	97	5831.5



17	5751.5	44	5778.5	71	5805.5	98	5832.5
18	5752.5	45	5779.5	72	5806.5	99	5833.5
19	5753.5	46	5780.5	73	5807.5	100	5834.5
20	5754.5	47	5781.5	74	5808.5	101	5835.5
21	5755.5	48	5782.5	75	5809.5	102	5836.5
22	5756.5	49	5783.5	76	5810.5	103	5837.5
23	5757.5	50	5784.5	77	5811.5	104	5838.5
24	5758.5	51	5785.5	78	5812.5	105	5839.5
25	5759.5	52	5786.5	79	5813.5	/	/
26	5760.5	53	5787.5	80	5814.5	/	/
27	5761.5	54	5788.5	81	5815.5	/	/

UNII-3 SRD 5G 40MHz Bandwidth (5745.5MHz-5829.5MHz)							
Channel	Frequency (MHz)	Channel	Frequency (MHz)	Channel	Frequency (MHz)	Channel	Frequency (MHz)
1	5745.5	23	5767.5	45	5789.5	67	5811.5
2	5746.5	24	5768.5	46	5790.5	68	5812.5
3	5747.5	25	5769.5	47	5791.5	69	5813.5
4	5748.5	26	5770.5	48	5792.5	70	5814.5
5	5749.5	27	5771.5	49	5793.5	71	5815.5
6	5750.5	28	5772.5	50	5794.5	72	5816.5
7	5751.5	29	5773.5	51	5795.5	73	5817.5
8	5752.5	30	5774.5	52	5796.5	74	5818.5
9	5753.5	31	5775.5	53	5797.5	75	5819.5
10	5754.5	32	5776.5	54	5798.5	76	5820.5
11	5755.5	33	5777.5	55	5799.5	77	5821.5
12	5756.5	34	5778.5	56	5800.5	78	5822.5
13	5757.5	35	5779.5	57	5801.5	79	5823.5
14	5758.5	36	5780.5	58	5802.5	80	5824.5
15	5759.5	37	5781.5	59	5803.5	81	5825.5
16	5760.5	38	5782.5	60	5804.5	82	5826.5
17	5761.5	39	5783.5	61	5805.5	83	5827.5
18	5762.5	40	5784.5	62	5806.5	84	5828.5
19	5763.5	41	5785.5	63	5807.5	85	5829.5
20	5764.5	42	5786.5	64	5808.5	/	/
21	5765.5	43	5787.5	65	5809.5	/	/
22	5766.5	44	5788.5	66	5810.5	/	/

5.4. DESCRIPTION OF AVAILABLE ANTENNAS

Antenna No.	Frequency (MHz)	Antenna Type	Max Antenna Gain (dBi)
0	5725~5850	Dipole antenna	3
1	5725~5850	Dipole antenna	3
2	5725~5850	Dipole antenna	3
3	5725~5850	Dipole antenna	3

The EUT support Cyclic Shift Diversity(CDD) mode.

MIMO output power port and MIMO PSD port summing was performed in accordance with KDB 662911 D01. For the CDD results the Directional Gain was calculated in accordance with the following method.

For output power measurements:

Directional gain= $G_{ANT} + \text{Array Gain} = 2.3 \text{ dBi}$

G_{ANT} : equal to the gain of the antenna having the highest gain

Array Gain = 0 dB (i.e., no array gain) for $N_{ANT} \leq 4$

For power spectral density (PSD) measurements:

Directional gain= $G_{ANT} + \text{Array Gain} = 6.01 \text{ dBi}$

Array Gain = $10 \log (N_{ANT}/N_{SS}) \text{ dB}$.

N_{ANT} : number of transmit antennas

N_{SS} : number of spatial streams, the worst case directional gain will occur when $N_{SS} = 1$

Note: The value of the antenna gain was declared by customer. The customer declared that SRD 2.4G and SRD 5G can't transmit simultaneously.

Test Mode	Transmit and Receive Mode	Description
1.4MHz Mode	<input checked="" type="checkbox"/> 2TX, 4RX	ANT 0,1, 2,3 can be used as transmitting and receiving antenna.
1.4MHz-CA Mode	<input checked="" type="checkbox"/> 2TX, 4RX	ANT 0,1, 2,3 can be used as transmitting and receiving antenna.
3MHz Mode	<input checked="" type="checkbox"/> 2TX, 4RX	ANT 0,1, 2,3 can be used as transmitting and receiving antenna.
3MHz-CA Mode	<input checked="" type="checkbox"/> 2TX, 4RX	ANT 0,1, 2,3 can be used as transmitting and receiving antenna.
10MHz Mode	<input checked="" type="checkbox"/> 2TX, 4RX	ANT 0,1, 2,3 can be used as transmitting and receiving antenna.
20MHz Mode	<input checked="" type="checkbox"/> 2TX, 4RX	ANT 0,1, 2,3 can be used as transmitting and receiving antenna.
40MHz Mode	<input checked="" type="checkbox"/> 2TX, 4RX	ANT 0,1, 2,3 can be used as transmitting and receiving antenna.

Note: The EUT only support 2TX4RX mode, and Only 4 TX models as ANT 0&1/ANT 0&3/ANT 2&1/ANT 2&3 were used.

5.5. THE WORSE CASE POWER SETTING PARAMETER

The Worse Case Power Setting Parameter under 5725 ~ 5850MHz Band				
Test Software		DjiSdrConsole		
Modulation Mode	Transmit Antenna Number	Test Software setting value		
		NCB: 1.4MHz/3MHz/10MHz/20MHz/40MHz		
		Low Channel	MID Channel	High Channel
All	All	Default	Default	Default

5.6. THE WORSE CASE CONFIGURATIONS

The EUT was tested in the following configuration(s):

Controlled in test mode using a software application on the EUT supplied by customer. The application was used to enable a continuous transmission and to select the mode, test channels, bandwidth, data rates as required.

Test channels referring to section 5.4.

Maximum power setting referring to section 5.6.

Worst case Data Rates declared by the customer:

- SRD 5G-1.4M Mode/QPSK
- SRD 5G-1.4M-CA Mode/QPSK
- SRD 5G-3M Mode/QPSK
- SRD 5G-3M-CA Mode/QPSK
- SRD 5G-10M Mode/QPSK
- SRD 5G-20M Mode/QPSK
- SRD 5G-40M Mode/QPSK

The EUT has 4 separate antennas which correspond to 4 separate antenna ports. The EUT only support 2TX4RX mode, and Only 4 TX models as ANT 0&1/ANT 0&3/ANT 2&1/ANT 2&3 were used.

The measured additional path loss was included in any path loss calculations for all RF cable used during tested.

Duty cycle and occupied channel bandwidth tests, only one chain were tested since the duty cycle and bandwidth does not change depending on chains used.

The EUT support Cyclic Shift Diversity (CDD), They use the same conducted power per chain in any given mode, so we only chose the worst-case mode CDD 2TX at ANT 0&1 for final testing.

5.7. DESCRIPTION OF TEST SETUP

SUPPORT EQUIPMENT

Item	Equipment	Brand Name	Model Name	Remarks
1	Laptop	Lenovo	ThinkPad E480	/
2	Earphone	apple	/	/
3	Monitor	DELL	P2419H	/
4	DJI Ronin 4D Hand Grips Combo	DJI	EGP	/
5	SD card	/	/	/

I/O CABLES

Cable No	Port	Connector Type	Cable Type	Cable Length(m)	Remarks
1	USB	/	/	1.0	/
2	HDMI Cable	NO	NO	1.5m	/
3	HDMI Cable	NO	NO	1.5m	/

ACCESSORIES

Item	Accessory	Brand Name	Model Name	Description
/	/	/	/	/

TEST SETUP

The EUT can work in engineering mode with a software.

SETUP DIAGRAM FOR TESTS

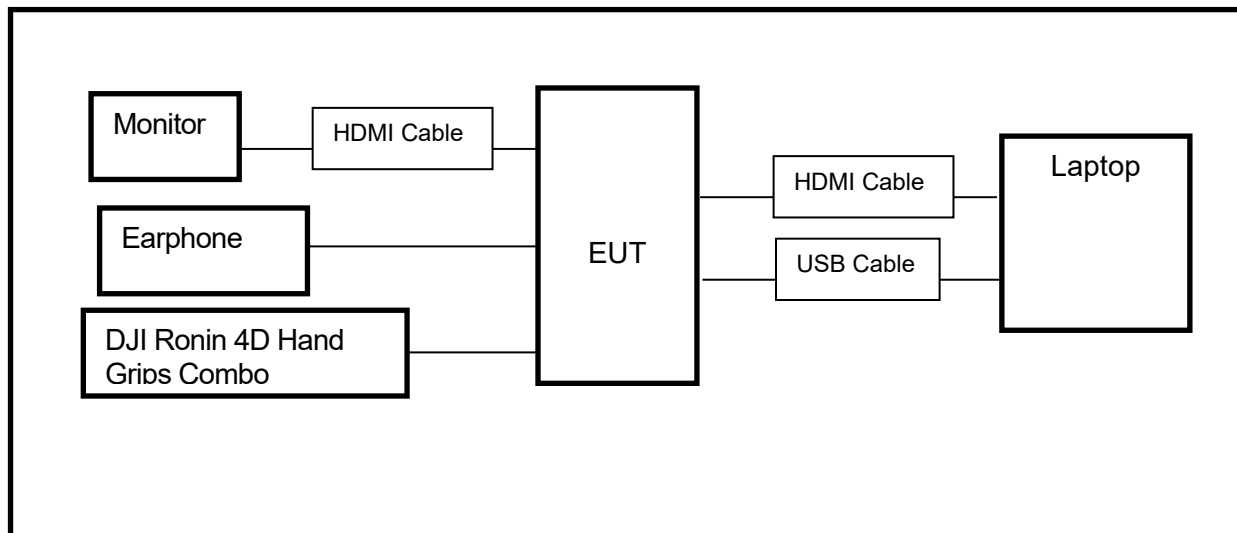

**6. MEASURING INSTRUMENT AND SOFTWARE USED**

Conducted Emissions					
Equipment	Manufacturer	Model No.	Serial No.	Last Cal.	Due Date
EMI Test Receiver	R&S	ESR3	101961	Nov. 12, 2020	Nov. 11, 2021
Two-Line V-Network	R&S	ENV216	101983	Nov. 12, 2020	Nov. 11, 2021
Software					
Description		Manufacturer	Name	Version	
Test Software for Conducted Emissions		Farad	EZ-EMC	Ver. UL-3A1	
Radiated Emissions					
Equipment	Manufacturer	Model No.	Serial No.	Last Cal.	Due Date
MXE EMI Receiver	KESIGHT	N9038A	MY56400036	Nov. 12, 2020	Nov. 11, 2021
Hybrid Log Periodic Antenna	TDK	HLP-3003C	130960	Aug. 11, 2018	Aug. 10, 2021
Preamplifier	HP	8447D	2944A09099	Nov. 12, 2020	Nov. 11, 2021
EMI Measurement Receiver	R&S	ESR26	101377	Nov. 12, 2020	Nov. 11, 2021
Horn Antenna	TDK	HRN-0118	130939	Sept. 17, 2018	Sept. 17, 2021
Preamplifier	TDK	PA-02-0118	TRS-305-00067	Nov. 20, 2020	Nov. 19, 2021
Horn Antenna	Schwarzbeck	BBHA9170	#691	Aug. 11, 2018	Aug. 11, 2021
Preamplifier	TDK	PA-02-2	TRS-307-00003	Nov. 12, 2020	Nov. 11, 2021
Preamplifier	TDK	PA-02-3	TRS-308-00002	Nov. 12, 2020	Nov. 11, 2021
Loop antenna	Schwarzbeck	1519B	00008	Jan.17, 2019	Jan.17,2022
Preamplifier	TDK	PA-02-001-3000	TRS-302-00050	Nov. 12, 2020	Nov. 11, 2021
Preamplifier	Mini-Circuits	ZX60-83LN-S+	SUP01201941	Nov. 20, 2020	Nov. 19, 2021
Band Reject Filter	Wainwright	WRCJV8-2350-2400-2483.5-2533.5-40SS	4	Nov. 12, 2020	Nov. 11, 2021
Highpass Filter	Wainwright	WHKX10-5850-6500-1800-40SS	4	Nov. 12, 2020	Nov. 11, 2021
Band Reject Filter	Wainwright	WRCJV12-5695-5725-5850-5880-40SS	4	Nov. 12, 2020	Nov. 11, 2021



Band Reject Filter	Wainwright	WRCJV20-5120-5150-5350-5380-60SS	2	Nov. 12, 2020	Nov. 11, 2021
Band Reject Filter	Wainwright	WRCJV20-5440-5470-5725-5755-60SS	1	Nov. 12, 2020	Nov. 11, 2021
Software					
Description		Manufacturer	Name	Version	
Test Software for Radiated Emissions		Farad	EZ-EMC	Ver. UL-3A1	

Tonsend RF Test System					
Equipment	Manufacturer	Model No.	Serial No.	Last Cal.	Due. Date
Wideband Radio Communication Tester	R&S	CMW500	155523	Nov.20,2020	Nov.19,2021
PXA Signal Analyzer	Keysight	N9030A	MY55410512	Nov.20,2020	Nov.19,2021
MXG Vector Signal Generator	Keysight	N5182B	MY56200284	Nov.20,2020	Nov.19,2021
MXG Vector Signal Generator	Keysight	N5172B	MY56200301	Nov.20,2020	Nov.19,2021
DC power supply	Keysight	E3642A	MY55159130	Nov.24,2020	Nov.23,2021
Temperature & Humidity Chamber	SANMOOD	SG-80-CC-2	2088	Nov.20,2020	Nov.19,2021
Software					
Description	Manufacturer	Name		Version	
Tonsend SRD Test System	Tonsend	JS1120-3 RF Test System		2.6.77.0518	

Other Instruments					
Equipment	Manufacturer	Model No.	Serial No.	Last Cal.	Next Cal.
Power sensor, Power Meter	R&S	OSP120	100921	Mar.23,2021	Mar.22,2022

7. ANTENNA PORT TEST RESULTS

7.1. ON TIME AND DUTY CYCLE

LIMITS

None; for reporting purposes only.

PROCEDURE

Refer to KDB 789033 D02 General U-NII Test Procedures New Rules v02r01 section II.B.

The zero-span mode on a spectrum analyzer or EMI receiver, if the response time and spacing between bins on the sweep are sufficient to permit accurate measurements of the on and off times of the transmitted signal. Set the center frequency of the instrument to the center frequency of the transmission. Set $RBW \geq EBW$ if possible; otherwise, set RBW to the largest available value. Set $VBW \geq RBW$. Set detector = peak or average. The zero-span measurement method shall not be used unless both RBW and VBW are $> 50/T$, where T is defined in II.B.1.a), and the number of sweep points across duration T exceeds 100. (For example, if VBW and/or RBW are limited to 3 MHz, then the zero-span method of measuring duty cycle shall not be used if $T \leq 16.7$ microseconds.)

TEST SETUP

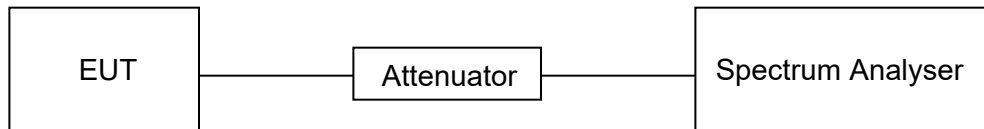

TEST ENVIRONMENT

Temperature	25.5 °C	Relative Humidity	59 %
Atmosphere Pressure	101 kPa	Test Voltage	DC 6.8V

RESULTS

Please refer to appendix D.



7.2. 6/26 dB EMISSION BANDWIDTH AND 99 % OCCUPIED BANDWIDTH

LIMITS

CFR 47 FCC Part15, Subpart E		
Test Item	Limit	Frequency Range (MHz)
26 dB Emission Bandwidth	For reporting purposes only.	5150 ~ 5250
26 dB Emission Bandwidth	For reporting purposes only.	5250 ~ 5350
26 dB Emission Bandwidth	For reporting purposes only.	5470 ~ 5725 (For FCC) 5470 ~ 5600 (For ISED) 5650 ~ 5725 (For ISED)
6 dB Emission Bandwidth	The minimum 6 dB emission bandwidth shall be 500 kHz.	5725 ~ 5850
99 % Occupied Bandwidth	For reporting purposes only.	5150 ~ 5825 (For ISED)

TEST PROCEDURE

ISED RSS-247 6.2.1.2 clause unwanted emission limits

For transmitters with operating frequencies in the band 5150-5250 MHz, all emissions outside the band 5150-5350 MHz shall not exceed -27 dBm/MHz e.i.r.p. Any unwanted emissions that fall into the band 5250-5350 MHz shall be attenuated below the channel power by at least 26 dB, when measured using a resolution bandwidth between 1 and 5% of the occupied bandwidth (i.e. 99% bandwidth), above 5250 MHz.

TEST PROCEDURE

Refer to KDB 789033 D02 General U-NII Test Procedures New Rules v02r01 section II.C1. for 26 dB Emission Bandwidth; section II.C2. for 6 dB Emission Bandwidth; section II.D. for 99 % Occupied Bandwidth.

Connect the EUT to the spectrum analyser and use the following settings:

Center Frequency	The center frequency of the channel under test
Detector	Peak
RBW	For 6 dB Emission Bandwidth: RBW=100 kHz For 26 dB Emission bandwidth: approximately 1 % of the EBW. For 99 % Occupied Bandwidth: approximately 1 % ~ 5 % of the OBW.
VBW	For 6 dB Bandwidth: $\geq 3 \times \text{RBW}$ For 26 dB Bandwidth: $> \text{RBW}$ For 99 % Bandwidth: $> 3 \times \text{RBW}$
Trace	Max hold
Sweep	Auto couple

a) Use the 99 % power bandwidth function of the instrument, allow the trace to stabilize and report the measured bandwidth.

b) Allow the trace to stabilize and measure the maximum width of the emission that is constrained by the frequencies associated with the two outermost amplitude points (upper and lower frequencies) that are attenuated by 6/26 dB relative to the maximum level measured in the fundamental emission.

TEST SETUP

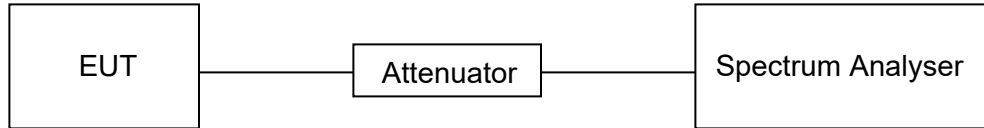

TEST ENVIRONMENT

Temperature	25.5 °C	Relative Humidity	59 %
Atmosphere Pressure	101 kPa	Test Voltage	DC 6.8V

RESULTS

Please refer to Appendix A1&A2.



7.3. CONDUCTED OUTPUT POWER

LIMITS

CFR 47 FCC Part15, Subpart E		
Test Item	Limit	Frequency Range (MHz)
Conducted Output Power	<input type="checkbox"/> Outdoor Access Point: 1 W (30 dBm) <input checked="" type="checkbox"/> Indoor Access Point: 1 W (30 dBm) <input type="checkbox"/> Fixed Point-To-Point Access Points: 1 W (30 dBm) <input type="checkbox"/> Client Devices: 250 mW (24 dBm)	5150 ~ 5250
	Shall not exceed the lesser of 250 mW (24dBm) or 11 dBm + 10 log B, where B is the 26 dB emission bandwidth in megahertz.	5250 ~ 5350 5470 ~ 5725
	Shall not exceed 1 Watt (30 dBm).	5725 ~ 5850

Note:

The above limits are based upon the maximum antenna gain does not exceed 6 dBi. If transmitting antennas of directional gain greater than 6 dBi are used, the maximum conducted output power shall be reduced by the amount in dB that the directional gain of the antenna exceeds 6 dBi.

TEST PROCEDURE

Refer to KDB 789033 D02 General U-NII Test Procedures New Rules v02r01 section II.E.

Method SA-1 (trace averaging with the EUT transmitting at full power throughout each sweep):

- (i) Set span to encompass the entire emission bandwidth (EBW) (or, alternatively, the entire 99% occupied bandwidth) of the signal.
- (ii) Set RBW = 1 MHz.
- (iii) Set VBW \geq 3 MHz.
- (iv) Number of points in sweep $\geq 2 \times$ span / RBW. (This ensures that bin-to-bin spacing is \leq RBW/2, so that narrowband signals are not lost between frequency bins.)
- (v) Sweep time = auto.
- (vi) Detector = power averaging (rms), if available. Otherwise, use sample detector mode.
- (vii) If transmit duty cycle $<$ 98 %, use a video trigger with the trigger level set to enable triggering only on full power pulses. Transmitter must operate at maximum power control level for the entire duration of every sweep. If the EUT transmits continuously (i.e., with no off intervals) or at duty cycle \geq 98 %, and if each transmission is entirely at the maximum power control level, then the trigger shall be set to "free run."
- (viii) Trace average at least 100 traces in power averaging (rms) mode.
- (ix) Compute power by integrating the spectrum across the EBW (or, alternatively, the entire 99% occupied bandwidth) of the signal using the instrument's band power measurement function with band limits set equal to the EBW (or occupied bandwidth) band edges. If the instrument does not have a band power function, sum the spectrum levels (in power units) at 1 MHz intervals extending across the EBW (or, alternatively, the entire 99% occupied bandwidth) of the spectrum.

Method PM (Measurement using an RF average power meter):

- (i) Measurements may be performed using a wideband RF power meter with a thermocouple detector or equivalent if all of the following conditions are satisfied:
 - a. The EUT is configured to transmit continuously or to transmit with a constant duty cycle.
 - b. At all times when the EUT is transmitting, it must be transmitting at its maximum power control level.
 - c. The integration period of the power meter exceeds the repetition period of the transmitted signal by at least a factor of five.
- (ii) If the transmitter does not transmit continuously, measure the duty cycle, x , of the transmitter output signal as described in II.B.
- (iii) Measure the average power of the transmitter. This measurement is an average over both the on and off periods of the transmitter.
- (iv) Adjust the measurement in dBm by adding $10 \log (1/x)$ where x is the duty cycle (e.g., $10 \log (1/0.25)$ if the duty cycle is 25 %).

Method PM-G (Measurement using a gated RF average power meter):

Measurements may be performed using a wideband gated RF power meter provided that the gate parameters are adjusted such that the power is measured only when the EUT is transmitting at its maximum power control level. Since the measurement is made only during the ON time of the transmitter, no duty cycle correction factor is required.

Straddle channel power was measured using spectrum analyzer.



TEST SETUP

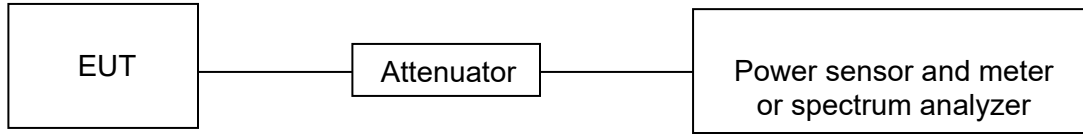

TEST ENVIRONMENT

Temperature	25.5 °C	Relative Humidity	59 %
Atmosphere Pressure	101 kPa	Test Voltage	DC 6.8V

RESULTS

Please refer to Appendix B.



7.4. POWER SPECTRAL DENSITY

LIMITS

CFR 47 FCC Part15, Subpart E		
Test Item	Limit	Frequency Range (MHz)
Power Spectral Density	<input type="checkbox"/> Outdoor Access Point: 17 dBm/MHz <input checked="" type="checkbox"/> Indoor Access Point: 17 dBm/MHz <input type="checkbox"/> Fixed Point-To-Point Access Points: 17 dBm/MHz <input type="checkbox"/> Client Devices: 11 dBm/MHz	5150 ~ 5250
	11 dBm/MHz	5250 ~ 5350 5470 ~ 5725
	30 dBm/500kHz	5725 ~ 5850

Note:

The above limits are based upon the maximum antenna gain does not exceed 6 dBi.
If transmitting antennas of directional gain greater than 6 dBi are used, maximum power spectral density shall be reduced by the amount in dB that the directional gain of the antenna exceeds 6 dBi.

TEST PROCEDURE

Refer to KDB 789033 D02 General U-NII Test Procedures New Rules v02r01 section II.F.

Connect the EUT to the spectrum analyser and use the following settings:

For U-NII-1, U-NII-2A and U-NII-2C band:

Center Frequency	The center frequency of the channel under test
Detector	RMS
RBW	1 MHz
VBW	$\geq 3 \times \text{RBW}$
Span	Encompass the entire emissions bandwidth (EBW) of the signal
Trace	Max hold
Sweep time	Auto

For U-NII-3:

Center Frequency	The center frequency of the channel under test
Detector	RMS
RBW	500 kHz
VBW	$\geq 3 \times \text{RBW}$
Span	Encompass the entire emissions bandwidth (EBW) of the signal
Trace	Max hold
Sweep time	Auto

Allow trace to fully stabilize and Use the peak search function on the instrument to find the peak of the spectrum and record its value.

Add $10 \log(1/x)$, where x is the duty cycle, to the peak of the spectrum, the result is the Maximum PSD over 1 MHz / 500 kHz reference bandwidth.

TEST SETUP

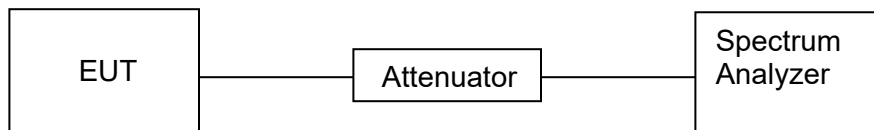

TEST ENVIRONMENT

Temperature	25.5 °C	Relative Humidity	59 %
Atmosphere Pressure	101 kPa	Test Voltage	DC 6.8V

RESULTS

Please refer to Appendix C.



8. RADIATED TEST RESULTS

LIMITS

Refer to CFR 47 FCC §15.205, §15.209 and §15.407 (b).

Radiation Disturbance Test Limit for FCC (Class B) (9 kHz ~ 1 GHz)

Emissions radiated outside of the specified frequency bands above 30 MHz			
Frequency Range (MHz)	Field Strength Limit (uV/m) at 3 m	Field Strength Limit (dBuV/m) at 3 m	
		Quasi-Peak	
30 - 88	100	40	
88 - 216	150	43.5	
216 - 960	200	46	
Above 960	500	54	
Above 1000	500	Peak	Average
		74	54

FCC Emissions radiated outside of the specified frequency bands below 30 MHz		
Frequency (MHz)	Field strength (microvolts/meter)	Measurement distance (meters)
0.009-0.490	2400/F(kHz)	300
0.490-1.705	24000/F(kHz)	30
1.705-30.0	30	30



FCC Restricted bands of operation refer to FCC §15.205 (a):

MHz	MHz	MHz	GHz
0.090-0.110	16.42-16.423	399.9-410	4.5-5.15
¹ 0.495-0.505	16.69475-16.69525	608-614	5.35-5.46
2.1735-2.1905	16.80425-16.80475	960-1240	7.25-7.75
4.125-4.128	25.5-25.67	1300-1427	8.025-8.5
4.17725-4.17775	37.5-38.25	1435-1626.5	9.0-9.2
4.20725-4.20775	73-74.6	1645.5-1646.5	9.3-9.5
6.215-6.218	74.8-75.2	1660-1710	10.6-12.7
6.26775-6.26825	108-121.94	1718.8-1722.2	13.25-13.4
6.31175-6.31225	123-138	2200-2300	14.47-14.5
8.291-8.294	149.9-150.05	2310-2390	15.35-16.2
8.362-8.366	156.52475-156.52525	2483.5-2500	17.7-21.4
8.37625-8.38675	156.7-156.9	2690-2900	22.01-23.12
8.41425-8.41475	162.0125-167.17	3260-3267	23.6-24.0
12.29-12.293	167.72-173.2	3332-3339	31.2-31.8
12.51975-12.52025	240-285	3345.8-3358	36.43-36.5
12.57675-12.57725	322-335.4	3600-4400	(²)
13.36-13.41			

Note: ¹Until February 1, 1999, this restricted band shall be 0.490-0.510 MHz.

²Above 38.6c

Limits of unwanted/undesirable emission out of the restricted bands refer to CFR 47 FCC §15.407 (b).

LIMITS OF RADIATED EMISSION MEASUREMENT (Above 1GHz)		
Frequency Range (MHz)	EIRP Limit	Field Strength Limit (dBuV/m) at 3 m
5150~5250 MHz	PK: -27 (dBm/MHz)	PK:68.2(dBμV/m)
5250~5350 MHz		
5470~5725 MHz		
5725~5850 MHz	PK: -27 (dBm/MHz) *1 PK: 10 (dBm/MHz) *2 PK: 15.6 (dBm/MHz) *3 PK: 27 (dBm/MHz) *4	PK: 68.2(dBμV/m) *1 PK: 105.2 (dBμV/m) *2 PK: 110.8(dBμV/m) *3 PK: 122.2 (dBμV/m) *4
<p>Note:</p> <p>*1 beyond 75 MHz or more above of the band edge.</p> <p>*2 below the band edge increasing linearly to 10 dBm/MHz at 25 MHz above.</p> <p>*3 below the band edge increasing linearly to a level of 15.6 dBm/MHz at 5 MHz above.</p> <p>*4 from 5 MHz above or below the band edge increasing linearly to a level of 27 dBm/MHz at the band edge.</p>		

TEST SETUP AND PROCEDURE

Below 30 MHz

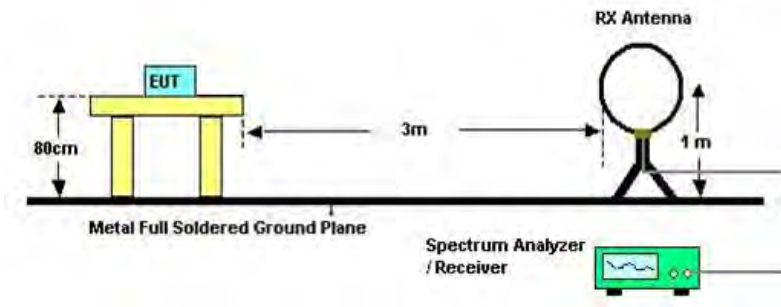

The setting of the spectrum analyser

RBW	200 Hz (From 9 kHz to 0.15 MHz) / 9 kHz (From 0.15 MHz to 30 MHz)
VBW	200 Hz (From 9 kHz to 0.15 MHz) / 9 kHz (From 0.15 MHz to 30 MHz)
Sweep	Auto
Trace	Max hold

1. The testing follows the guidelines in ANSI C63.10-2013 clause 6.4.
2. The EUT was arranged to its worst case and then turntable (from 0 degree to 360 degrees) to find the maximum reading. A pre-amp and a high pass filter are used for the test in order to get better signal level. Both Horizontal, Face-on and Face-off polarizations of the antenna are set to make the measurement.
3. The EUT was placed on a turntable with 80 cm above ground.
4. The EUT was set 3 meters from the interference receiving antenna, which was mounted on the top of a 1 m height antenna tower.
5. The radiated emission limits are based on measurements employing a CISPR quasi-peak detector except for the frequency bands 9-90 kHz, 110-490 kHz and above 1000 MHz. Radiated emission limits in these three bands are based on measurements employing an average detector.
6. For measurement below 1 GHz, the initial step in collecting conducted emission data is a spectrum analyzer peak detector mode pre-scanning the measurement frequency range. Significant peaks are then marked and then Quasi Peak and average detector mode re-measured. If the emission level of the EUT measured by the peak detector is 3 dB lower than the applicable limit, the peak emission level will be reported. Otherwise, the emission measurement will be repeated using the quasi-peak and average detector and reported.
7. Although these tests were performed other than open field site, adequate comparison measurements were confirmed against 30 m open field site. Therefore sufficient tests were made to demonstrate that the alternative site produces results that correlate with the ones of tests made in an open field site based on KDB 414788.

Below 1 GHz and above 30 MHz

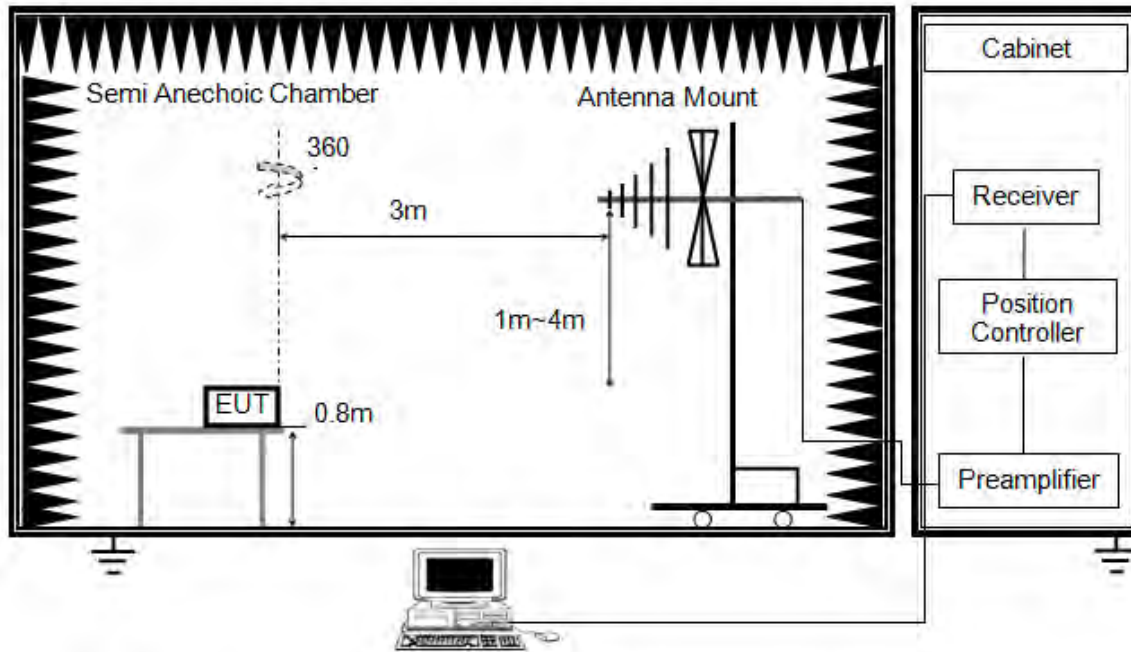

The setting of the spectrum analyser

RBW	120 kHz
VBW	300 kHz
Sweep	Auto
Detector	Peak/QP
Trace	Max hold

1. The testing follows the guidelines in ANSI C63.10-2013 clause 6.5.
2. The EUT was arranged to its worst case and then tune the antenna tower (from 1 m to 4 m) and turntable (from 0 degree to 360 degrees) to find the maximum reading. A pre-amp and a high pass filter are used for the test in order to get better signal level. Both horizontal and vertical polarizations of the antenna are set to make the measurement.
3. The EUT was placed on a turntable with 80 cm above ground.
4. The EUT was set 3 meters from the interference receiving antenna, which was mounted on the top of a variable height antenna tower.
5. For measurement below 1 GHz, the initial step in collecting conducted emission data is a spectrum analyzer peak detector mode pre-scanning the measurement frequency range. Significant peaks are then marked and then Quasi Peak detector mode re-measured. If the emission level of the EUT measured by the peak detector is 3 dB lower than the applicable limit, the peak emission level will be reported. Otherwise, the emission measurement will be repeated using the quasi-peak detector and reported.

Above 1 GHz

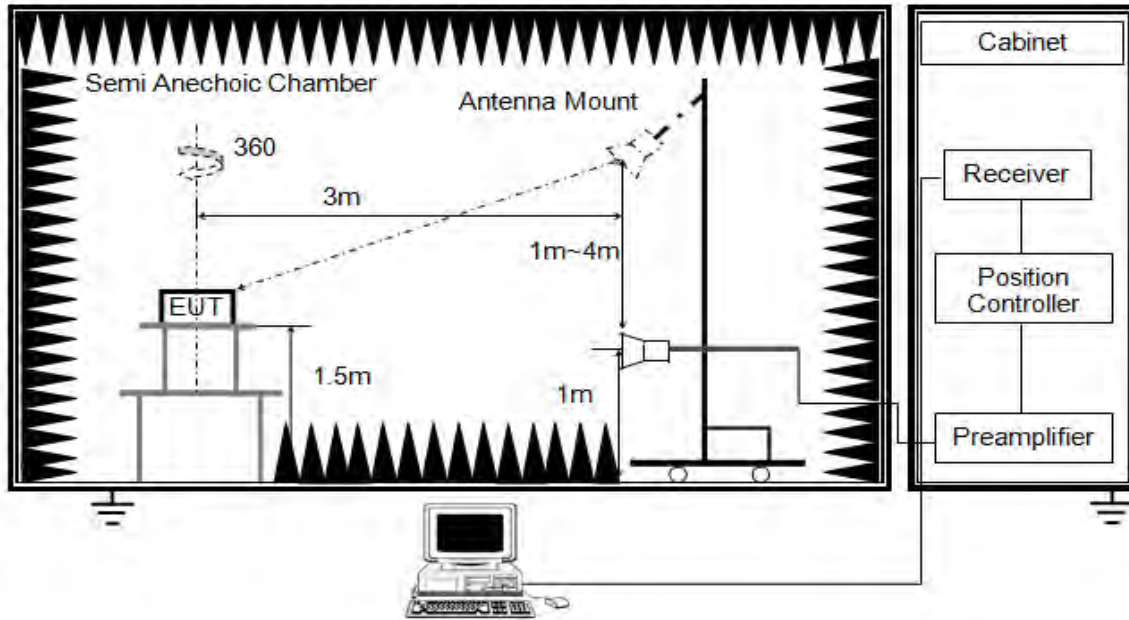

The setting of the spectrum analyser

RBW	1 MHz
VBW	PEAK: 3 MHz AVG: see note 6
Sweep	Auto
Detector	Peak
Trace	Max hold

1. The testing follows the guidelines in KDB 789033 D02 General U-NII Test Procedures New Rules v02r01 section II.G.3 ~ II.G.6.
2. The EUT was arranged to its worst case and then tune the antenna tower (from 1 m to 4 m) and turntable (from 0 degree to 360 degrees) to find the maximum reading. A pre-amp and a high pass filter are used for the test in order to get better signal level. Both horizontal and vertical polarizations of the antenna are set to make the measurement.
3. The EUT was placed on a turntable with 1.5 m above ground.
4. The EUT was set 3 meters from the interference receiving antenna, which was mounted on the top of a variable height antenna tower.
5. For measurement above 1 GHz, the emission measurement will be measured by the peak detector. This peak level, once corrected, must comply with the limit specified in Section 15.209.
6. For measurements above 1 GHz the resolution bandwidth is set to 1 MHz, then the video bandwidth is set to 3 MHz for peak measurements and 1 MHz resolution bandwidth with 1/T video bandwidth with peak detector for average measurements. For the Duty Cycle please refer to clause 7.1.ON TIME AND DUTY CYCLE.

X axis, Y axis, Z axis positions:

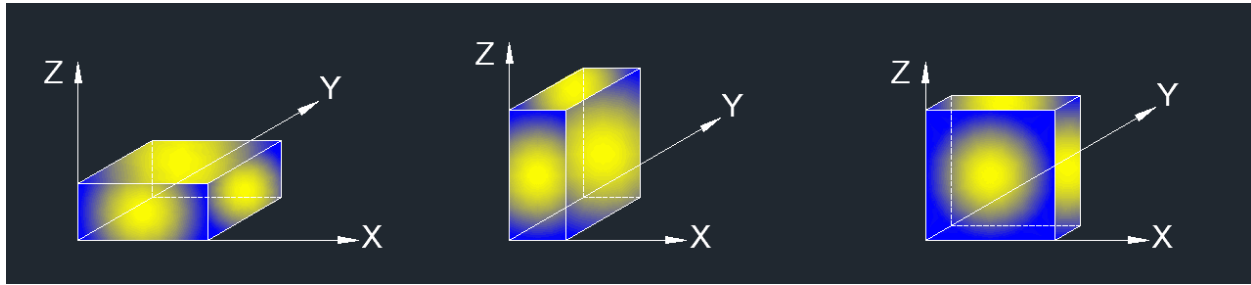

Note 1: For all radiated test, EUT in each of three orthogonal axis emissions had been tested, but only the worst case (X axis) data recorded in the report.

Note 2: The EUT do not support transmit simultaneously for SRD 2.4G and SRD 5G.

Note 3: The EUT was fully exercised with external accessories during the test. In the case of multiple accessory external ports, an external accessory shall be connected to one of each type of port.

TEST ENVIRONMENT

Temperature	23.5 °C	Relative Humidity	62 %
Atmosphere Pressure	101 kPa	Test Voltage	DC 6.8V

RESULTS

8.1. RESTRICTED BANDEDGE

8.1.1. 5G SRD 1.4MHz MODE

UNII-3 BAND

RESTRICTED BANDEDGE (LOW CHANNEL, HORIZONTAL)

PEAK

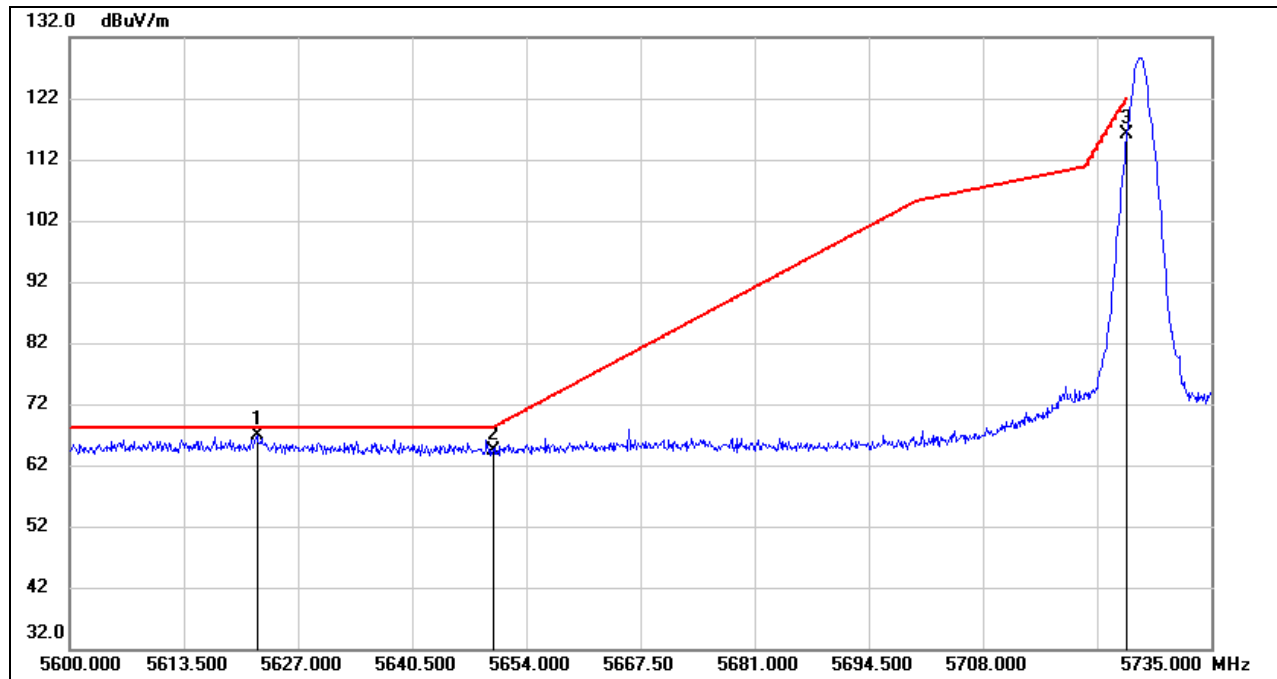

No.	Frequency (MHz)	Reading (dBuV)	Correct (dB/m)	Result (dBuV/m)	Limit (dBuV/m)	Margin (dB)	Remark
1	5622.140	25.23	41.69	66.92	68.20	-1.28	peak
2	5650.000	22.70	41.64	64.34	68.20	-3.86	peak
3	5725.000	74.47	41.67	116.14	122.20	-6.06	peak

- Note: 1. Measurement = Reading Level + Correct Factor.
 2. If Peak Result complies with AV limit, AV Result is deemed to comply with AV limit.
 3. Peak: Peak detector.
 4. Only the worst data was recorded, if it complies with the limit, the other emissions deemed to comply with the limit.

RESTRICTED BANDEDGE (HIGH CHANNEL, HORIZONTAL)

PEAK

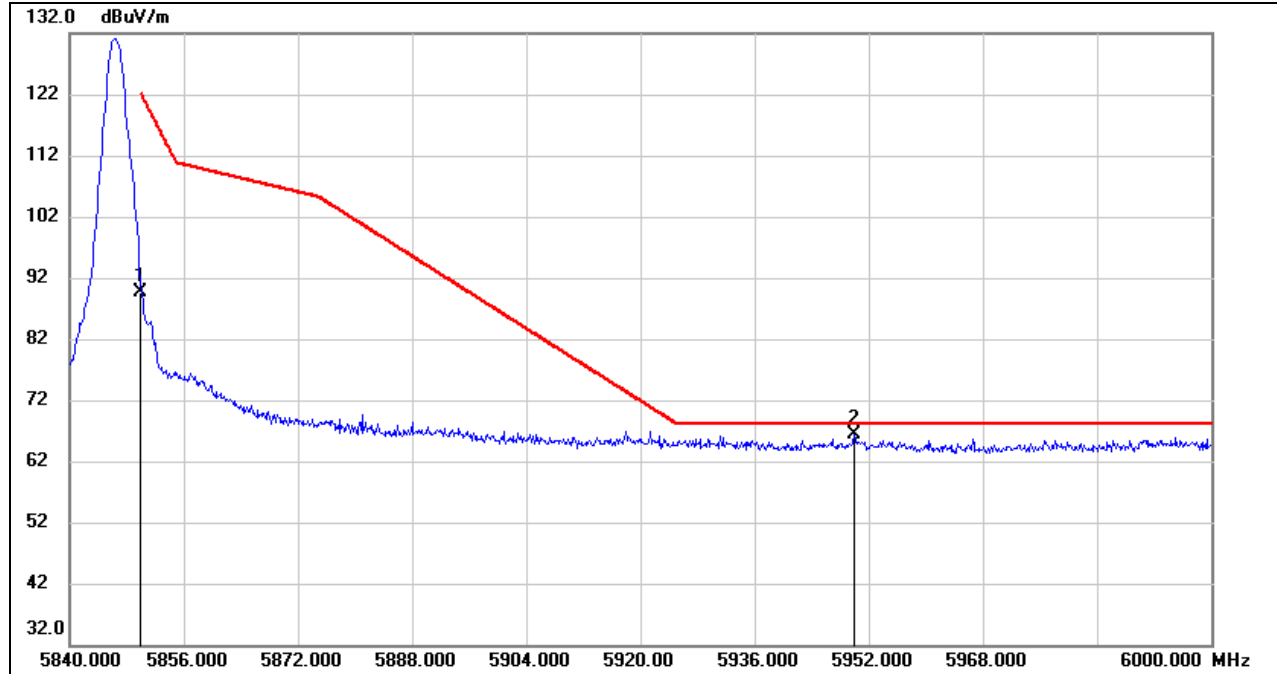

No.	Frequency (MHz)	Reading (dBuV)	Correct (dB/m)	Result (dBuV/m)	Limit (dBuV/m)	Margin (dB)	Remark
1	5850.000	47.13	42.52	89.65	122.20	-32.55	peak
2	5949.920	23.47	42.80	66.27	68.20	-1.93	peak

- Note: 1. Measurement = Reading Level + Correct Factor.
 2. If Peak Result complies with AV limit, AV Result is deemed to comply with AV limit.
 3. Peak: Peak detector.
 4. Only the worst data was recorded, if it complies with the limit, the other emissions deemed to comply with the limit.

Note: All the modes and antennas had been tested, but only the worst data was recorded in the report.

Note: Both horizontal and vertical had been tested, but only the worst data was recorded in the report.

8.1.2. 5G SRD 1.4MHz CA MODE

UNII-3 BAND

RESTRICTED BANDEDGE (LOW CHANNEL, HORIZONTAL)

PEAK

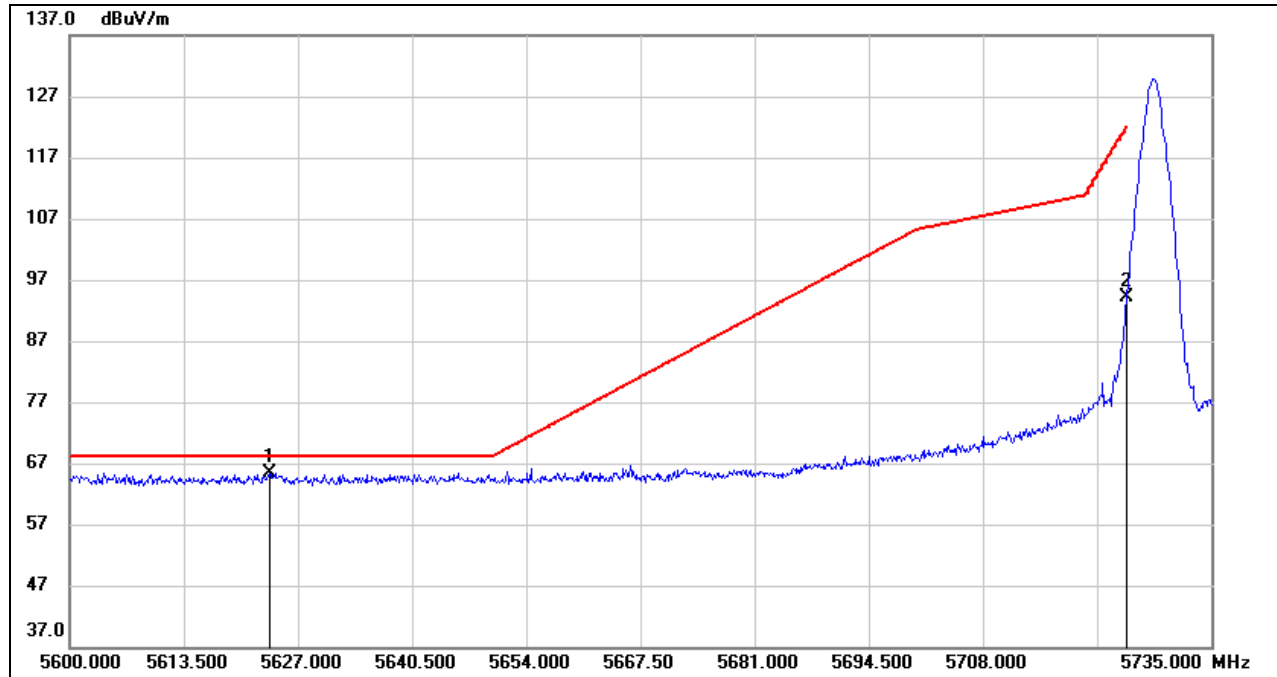

No.	Frequency (MHz)	Reading (dBuV)	Correct (dB/m)	Result (dBuV/m)	Limit (dBuV/m)	Margin (dB)	Remark
1	5623.625	23.77	41.69	65.46	68.20	-2.74	peak
2	5725.000	52.56	41.67	94.23	122.20	-27.97	peak

- Note: 1. Measurement = Reading Level + Correct Factor.
 2. If Peak Result complies with AV limit, AV Result is deemed to comply with AV limit.
 3. Peak: Peak detector.
 4. Only the worst data was recorded, if it complies with the limit, the other emissions deemed to comply with the limit.

RESTRICTED BANDEDGE (HIGH CHANNEL, HORIZONTAL)

PEAK

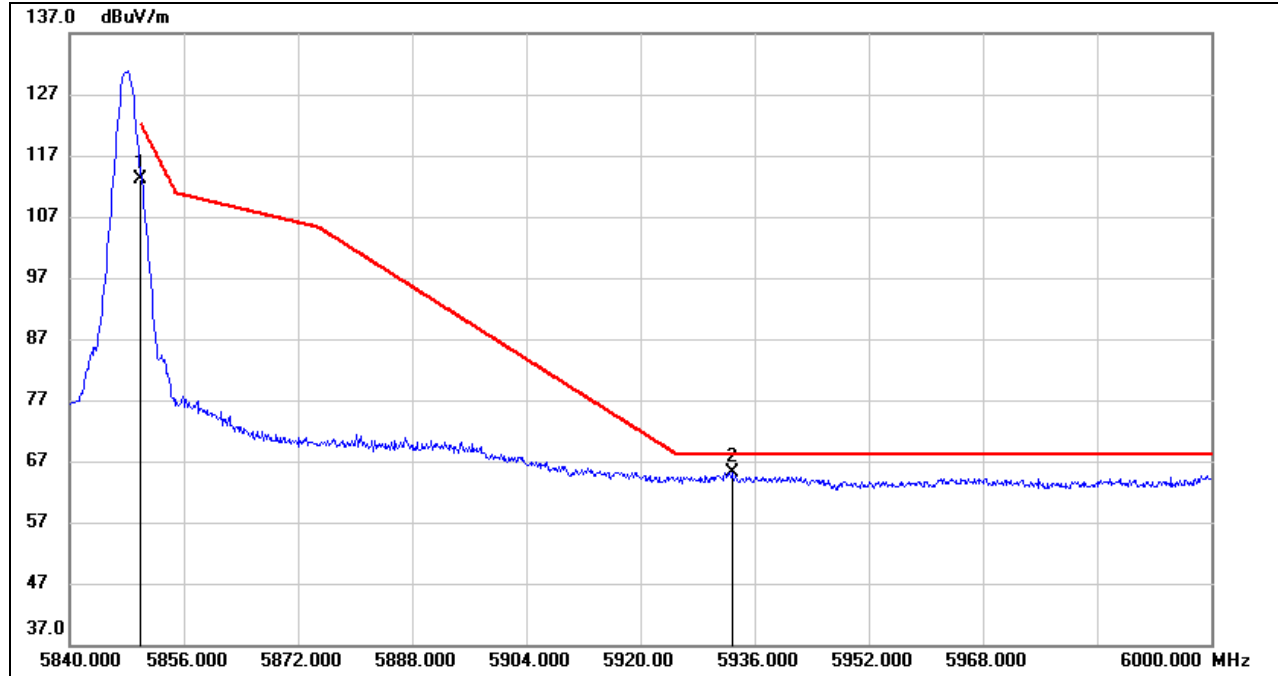

No.	Frequency (MHz)	Reading (dBuV)	Correct (dB/m)	Result (dBuV/m)	Limit (dBuV/m)	Margin (dB)	Remark
1	5850.000	70.51	42.52	113.03	122.20	-9.17	peak
2	5932.800	22.29	42.88	65.17	68.20	-3.03	peak

- Note: 1. Measurement = Reading Level + Correct Factor.
 2. If Peak Result complies with AV limit, AV Result is deemed to comply with AV limit.
 3. Peak: Peak detector.
 4. Only the worst data was recorded, if it complies with the limit, the other emissions deemed to comply with the limit.

Note: All the modes and antennas had been tested, but only the worst data was recorded in the report.

Note: Both horizontal and vertical had been tested, but only the worst data was recorded in the report.

8.1.3. 5G SRD 3MHz MODE

UNII-3 BAND

RESTRICTED BANDEDGE (LOW CHANNEL, HORIZONTAL)

PEAK

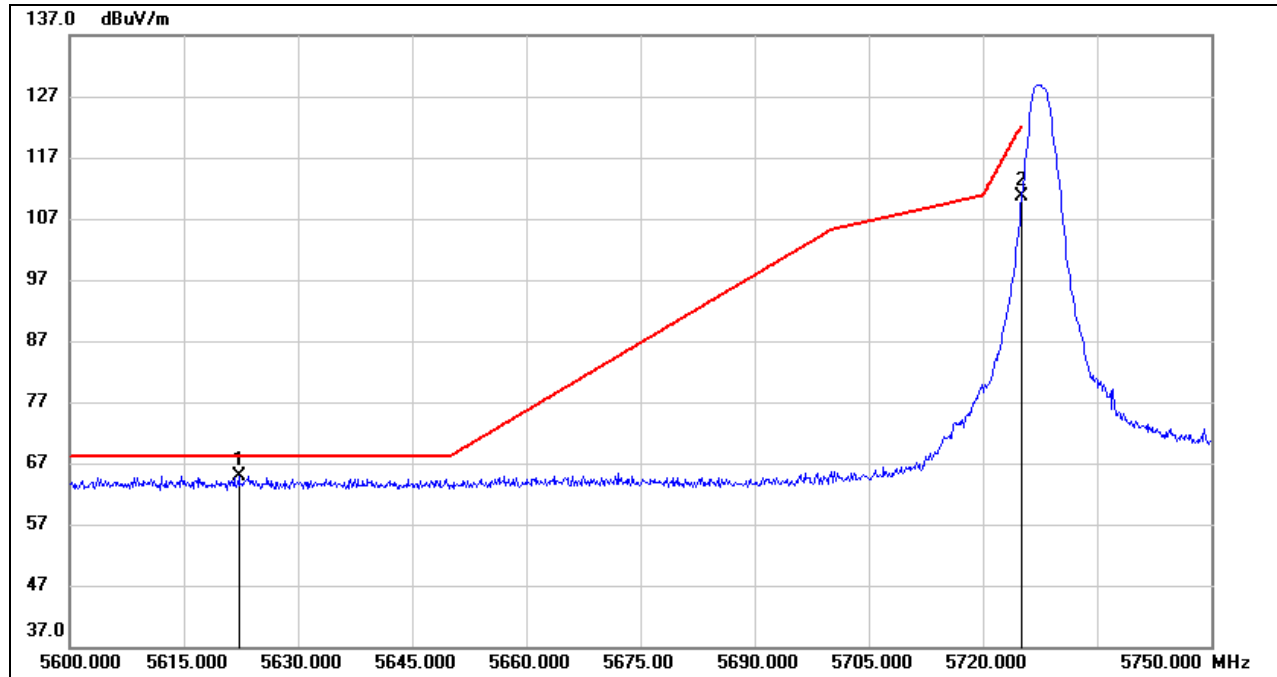

No.	Frequency (MHz)	Reading (dBuV)	Correct (dB/m)	Result (dBuV/m)	Limit (dBuV/m)	Margin (dB)	Remark
1	5622.200	23.24	41.69	64.93	68.20	-3.27	peak
2	5725.000	69.02	41.67	110.69	122.20	-11.51	peak

- Note: 1. Measurement = Reading Level + Correct Factor.
 2. If Peak Result complies with AV limit, AV Result is deemed to comply with AV limit.
 3. Peak: Peak detector.
 4. Only the worst data was recorded, if it complies with the limit, the other emissions deemed to comply with the limit.

RESTRICTED BANDEDGE (HIGH CHANNEL, HORIZONTAL)

PEAK

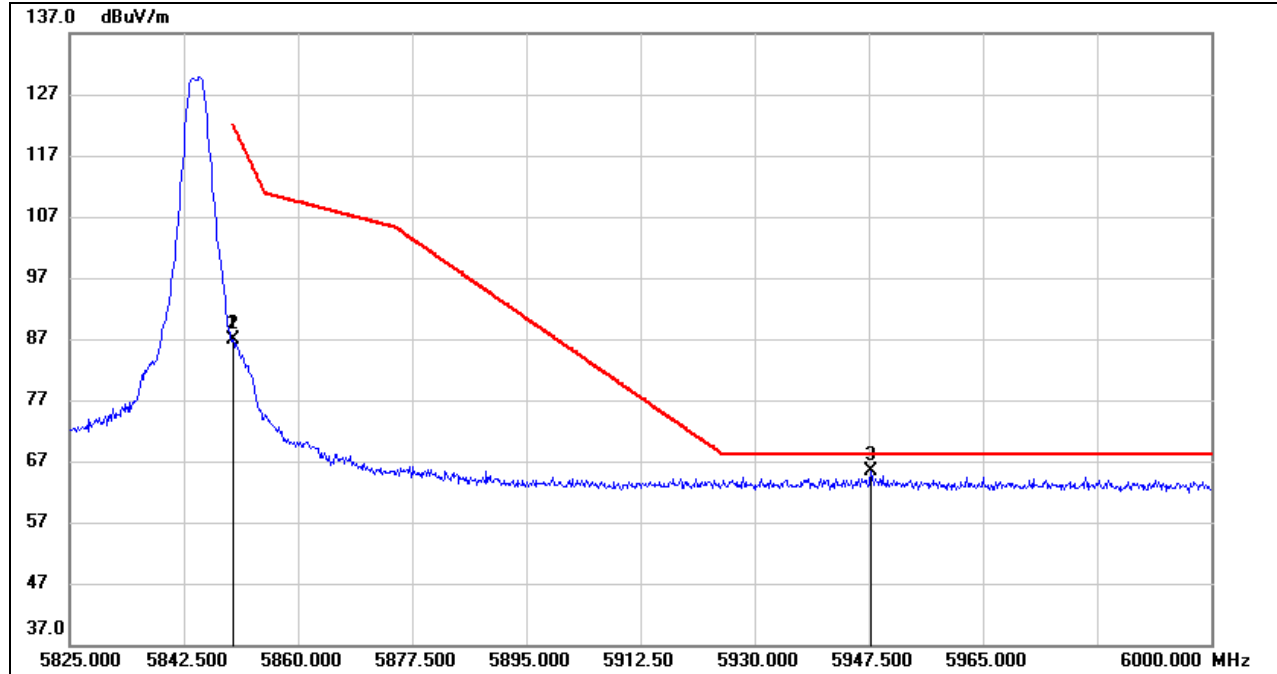

No.	Frequency (MHz)	Reading (dBuV)	Correct (dB/m)	Result (dBuV/m)	Limit (dBuV/m)	Margin (dB)	Remark
1	5850.000	44.29	42.52	86.81	122.20	-35.39	peak
2	5850.025	44.28	42.53	86.81	122.14	-35.33	peak
3	5947.850	22.54	42.81	65.35	68.20	-2.85	peak

- Note: 1. Measurement = Reading Level + Correct Factor.
 2. If Peak Result complies with AV limit, AV Result is deemed to comply with AV limit.
 3. Peak: Peak detector.
 4. Only the worst data was recorded, if it complies with the limit, the other emissions deemed to comply with the limit.

Note: All the modes and antennas had been tested, but only the worst data was recorded in the report.

Note: Both horizontal and vertical had been tested, but only the worst data was recorded in the report.

8.1.4. 5G SRD 3MHz CA MODE

UNII-3 BAND

RESTRICTED BANDEDGE (LOW CHANNEL, HORIZONTAL)

PEAK

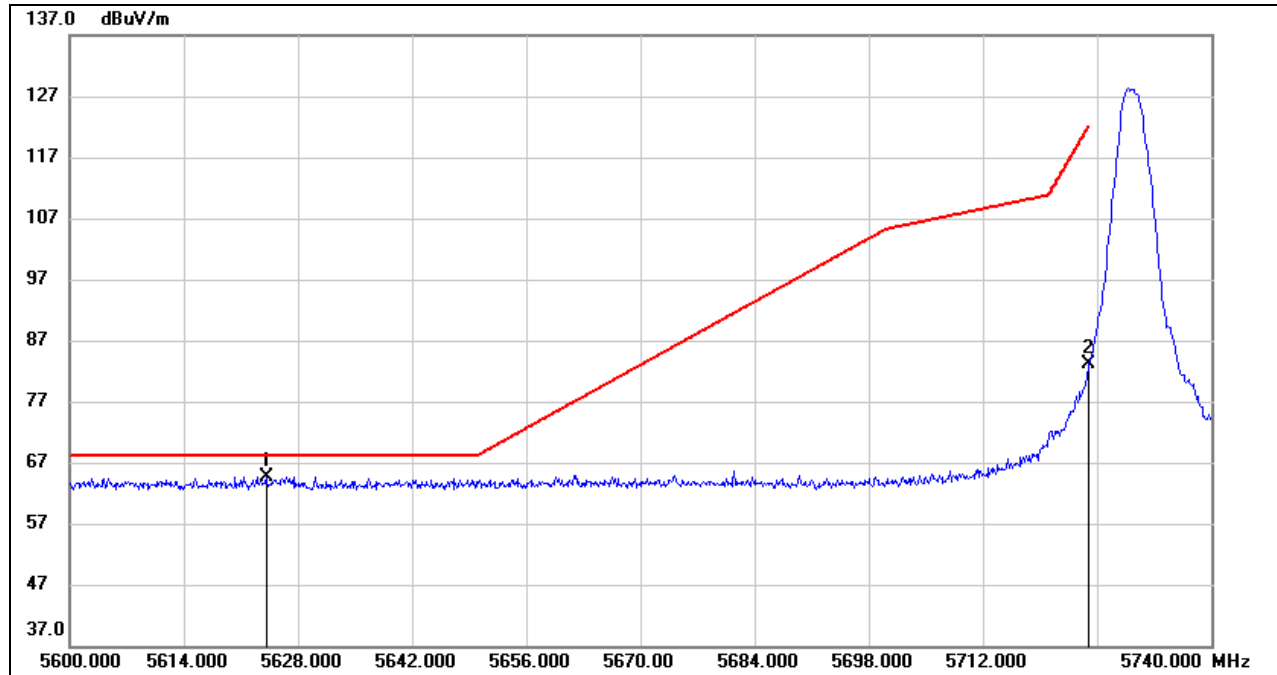

No.	Frequency (MHz)	Reading (dBuV)	Correct (dB/m)	Result (dBuV/m)	Limit (dBuV/m)	Margin (dB)	Remark
1	5624.080	22.98	41.69	64.67	68.20	-3.53	peak
2	5725.000	41.51	41.67	83.18	122.20	-39.02	peak

- Note:
1. Measurement = Reading Level + Correct Factor.
 2. If Peak Result complies with AV limit, AV Result is deemed to comply with AV limit.
 3. Peak: Peak detector.
 4. Only the worst data was recorded, if it complies with the limit, the other emissions deemed to comply with the limit.

RESTRICTED BANDEDGE (HIGH CHANNEL, HORIZONTAL)

PEAK

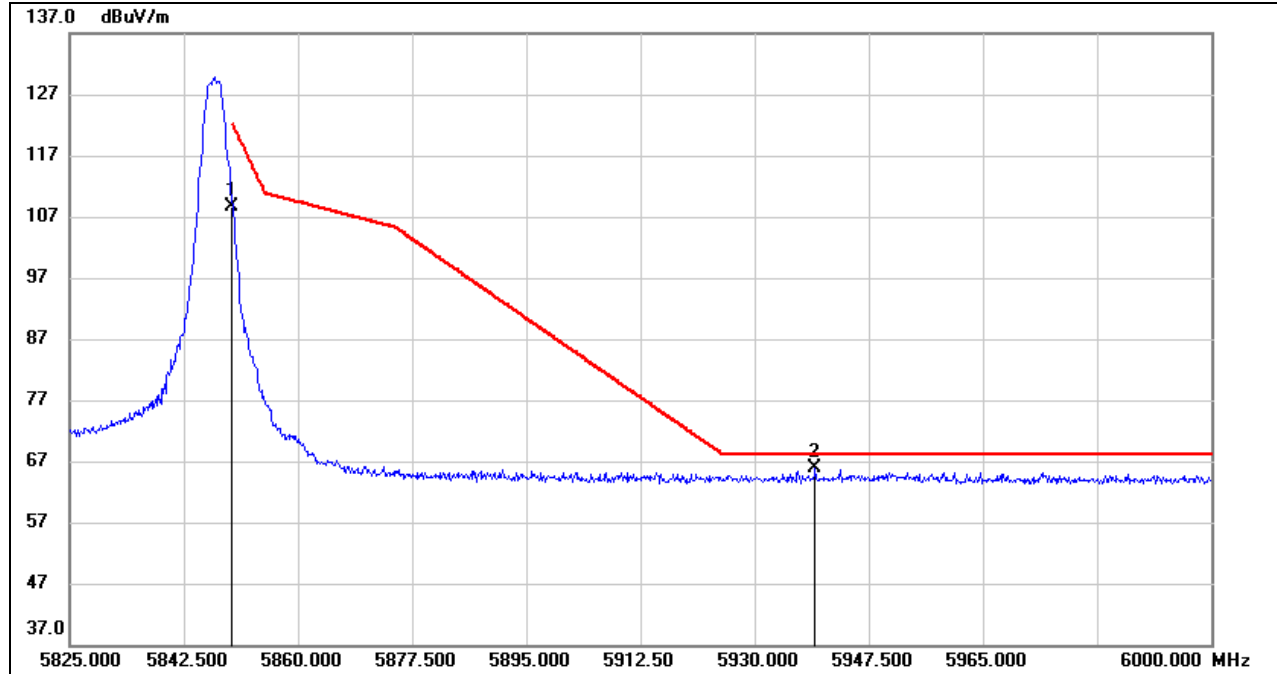

No.	Frequency (MHz)	Reading (dBuV)	Correct (dB/m)	Result (dBuV/m)	Limit (dBuV/m)	Margin (dB)	Remark
1	5850.000	66.21	42.52	108.73	122.20	-13.47	peak
2	5939.275	22.93	42.85	65.78	68.20	-2.42	peak

- Note: 1. Measurement = Reading Level + Correct Factor.
 2. If Peak Result complies with AV limit, AV Result is deemed to comply with AV limit.
 3. Peak: Peak detector.
 4. Only the worst data was recorded, if it complies with the limit, the other emissions deemed to comply with the limit.

Note: All the modes and antennas had been tested, but only the worst data was recorded in the report.

Note: Both horizontal and vertical had been tested, but only the worst data was recorded in the report.

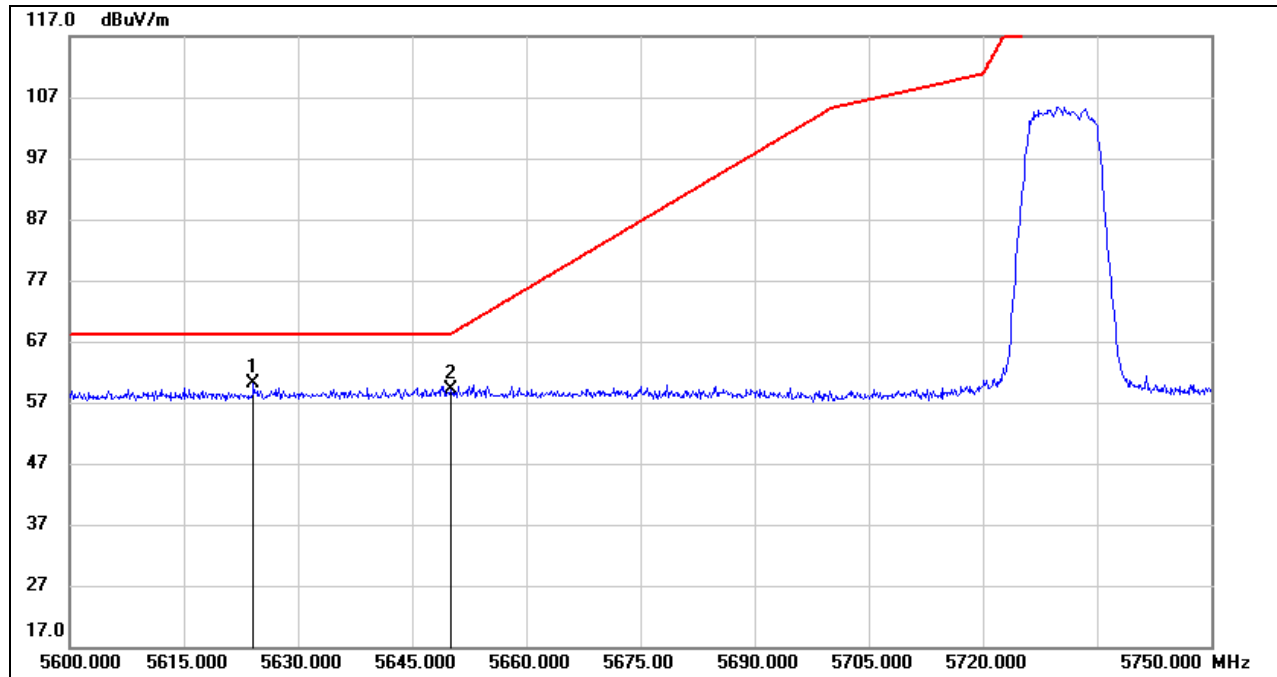
**8.1.5. 5G SRD 10MHz MODE****UNII-3 BAND****RESTRICTED BANDEDGE (LOW CHANNEL, HORIZONTAL)****PEAK**

No.	Frequency (MHz)	Reading (dBuV)	Correct (dB/m)	Result (dBuV/m)	Limit (dBuV/m)	Margin (dB)	Remark
1	5624.150	18.53	41.69	60.22	68.20	-7.98	peak
2	5650.000	17.52	41.64	59.16	68.20	-9.04	peak

Note: 1. Measurement = Reading Level + Correct Factor.

2. If Peak Result complies with AV limit, AV Result is deemed to comply with AV limit.

3. Peak: Peak detector.

4. Only the worst data was recorded, if it complies with the limit, the other emissions deemed to comply with the limit.

RESTRICTED BANDEDGE (HIGH CHANNEL, HORIZONTAL)

PEAK

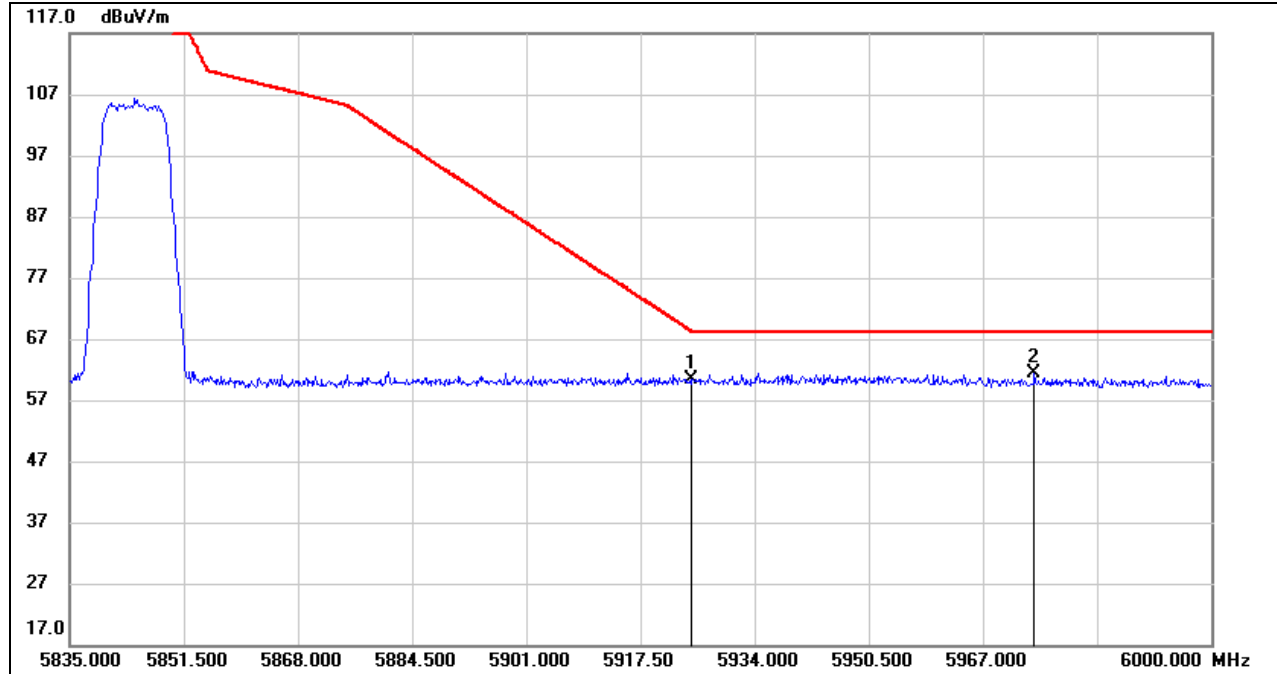

No.	Frequency (MHz)	Reading (dBuV)	Correct (dB/m)	Result (dBuV/m)	Limit (dBuV/m)	Margin (dB)	Remark
1	5925.000	17.50	42.91	60.41	68.20	-7.79	peak
2	5974.425	18.78	42.68	61.46	68.20	-6.74	peak

Note: 1. Measurement = Reading Level + Correct Factor.
 2. If Peak Result complies with AV limit, AV Result is deemed to comply with AV limit.
 3. Peak: Peak detector.
 4. Only the worst data was recorded, if it complies with the limit, the other emissions deemed to comply with the limit.

Note: All the modes and antennas had been tested, but only the worst data was recorded in the report.

Note: Both horizontal and vertical had been tested, but only the worst data was recorded in the report.

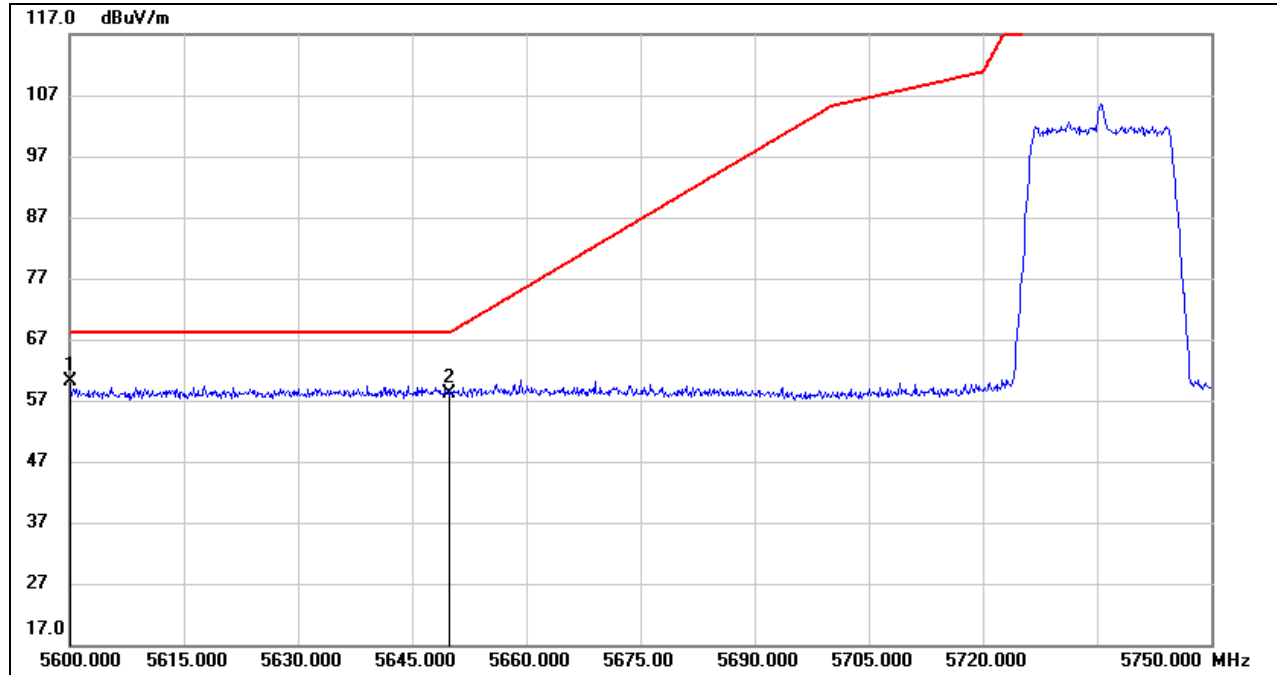
**8.1.6. 5G SRD 20MHz MODE****UNII-3 BAND****RESTRICTED BANDEDGE (LOW CHANNEL, HORIZONTAL)****PEAK**

No.	Frequency (MHz)	Reading (dBuV)	Correct (dB/m)	Result (dBuV/m)	Limit (dBuV/m)	Margin (dB)	Remark
1	5600.000	18.45	41.73	60.18	68.20	-8.02	peak
2	5650.000	16.53	41.64	58.17	68.20	-10.03	peak

Note: 1. Measurement = Reading Level + Correct Factor.
 2. If Peak Result complies with AV limit, AV Result is deemed to comply with AV limit.
 3. Peak: Peak detector.
 4. Only the worst data was recorded, if it complies with the limit, the other emissions deemed to comply with the limit.

RESTRICTED BANDEDGE (HIGH CHANNEL, HORIZONTAL)

PEAK

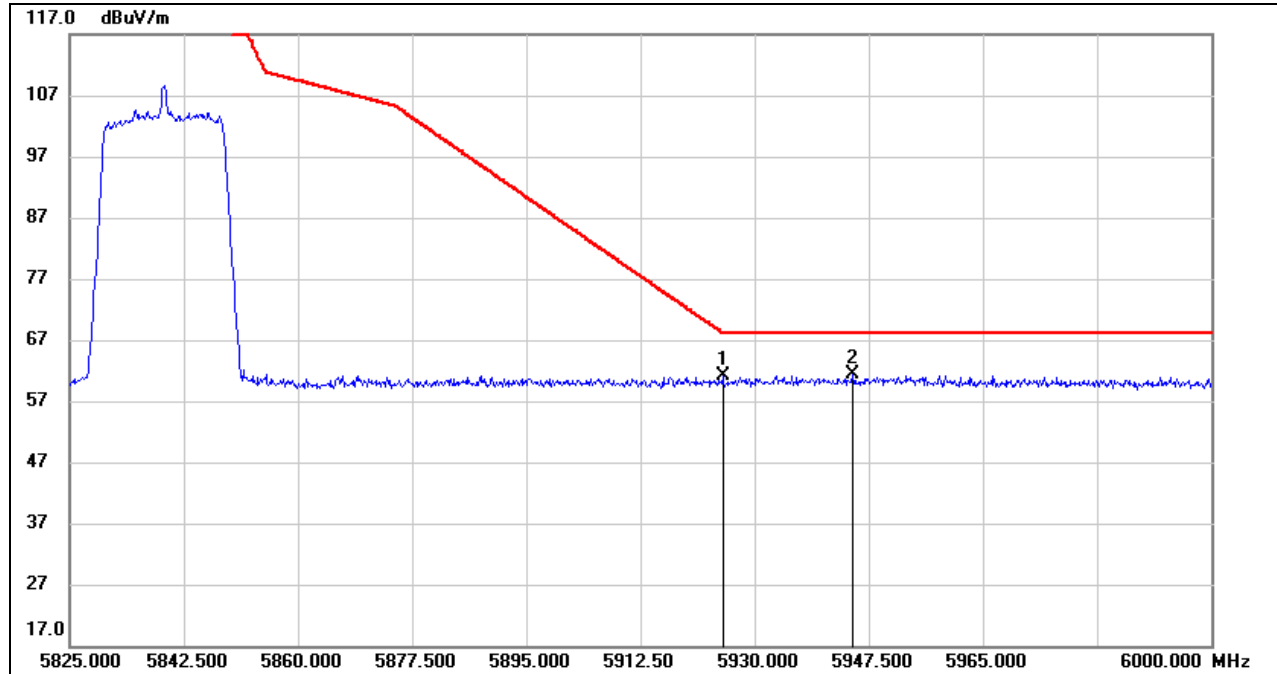

No.	Frequency (MHz)	Reading (dBuV)	Correct (dB/m)	Result (dBuV/m)	Limit (dBuV/m)	Margin (dB)	Remark
1	5925.000	18.25	42.91	61.16	68.20	-7.04	peak
2	5945.050	18.45	42.81	61.26	68.20	-6.94	peak

- Note: 1. Measurement = Reading Level + Correct Factor.
 2. If Peak Result complies with AV limit, AV Result is deemed to comply with AV limit.
 3. Peak: Peak detector.
 4. Only the worst data was recorded, if it complies with the limit, the other emissions deemed to comply with the limit.

Note: All the modes and antennas had been tested, but only the worst data was recorded in the report.

Note: Both horizontal and vertical had been tested, but only the worst data was recorded in the report.



8.1.7. 5G SRD 40MHz MODE

UNII-3 BAND

RESTRICTED BANDEDGE (LOW CHANNEL, HORIZONTAL)

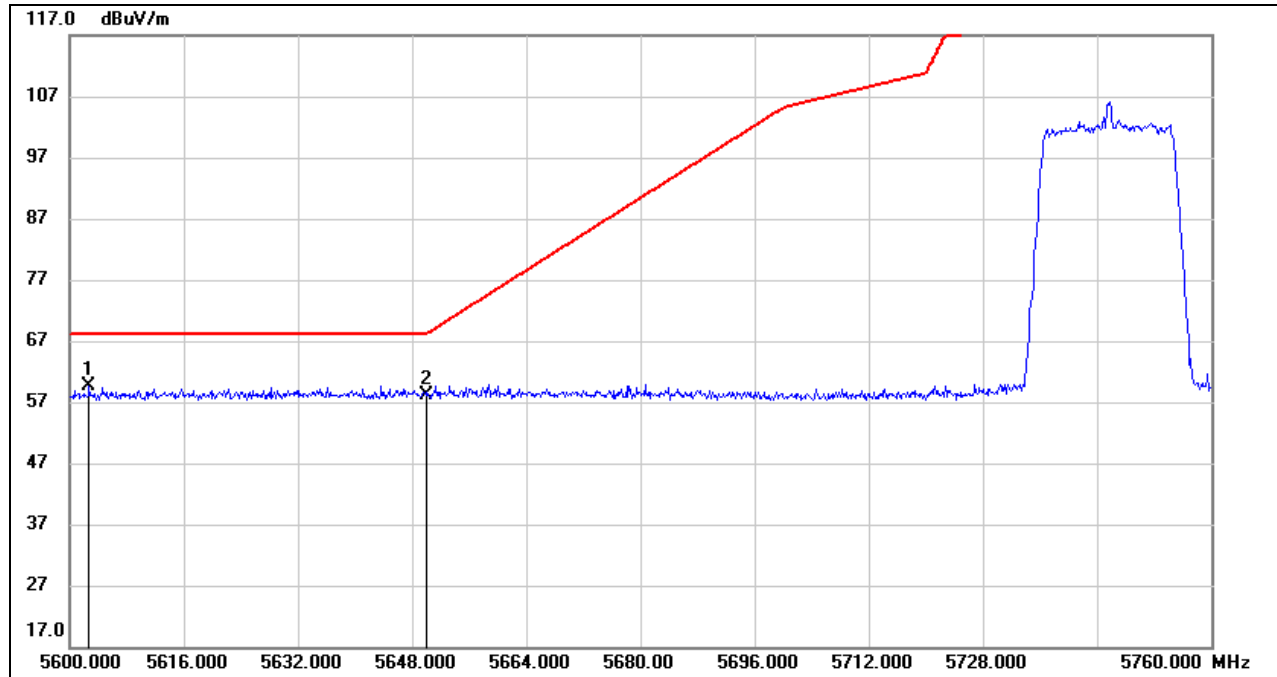

No.	Frequency (MHz)	Reading (dBuV)	Correct (dB/m)	Result (dBuV/m)	Limit (dBuV/m)	Margin (dB)	Remark
1	5602.720	17.88	41.72	59.60	68.20	-8.60	peak
2	5650.000	16.59	41.64	58.23	68.20	-9.97	peak

- Note: 1. Measurement = Reading Level + Correct Factor.
 2. If Peak Result complies with AV limit, AV Result is deemed to comply with AV limit.
 3. Peak: Peak detector.
 4. Only the worst data was recorded, if it complies with the limit, the other emissions deemed to comply with the limit.



RESTRICTED BANDEDGE (HIGH CHANNEL, HORIZONTAL)

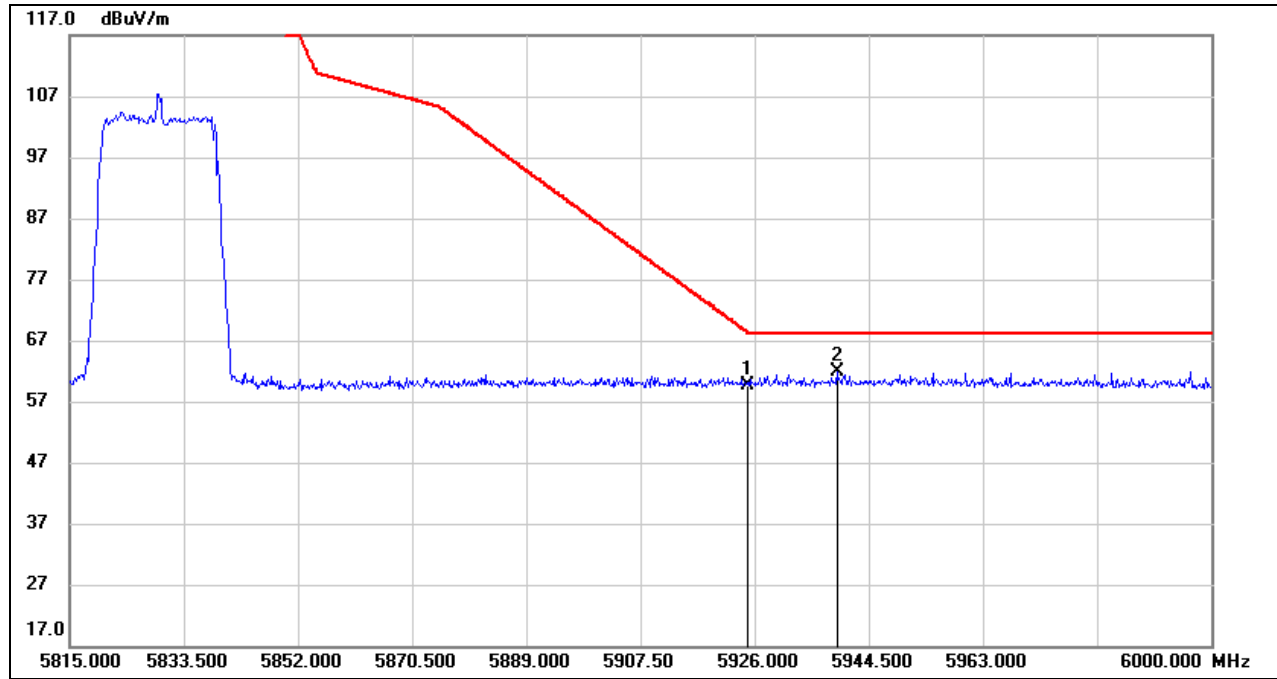

No.	Frequency (MHz)	Reading (dBuV)	Correct (dB/m)	Result (dBuV/m)	Limit (dBuV/m)	Margin (dB)	Remark
1	5925.000	16.77	42.91	59.68	68.20	-8.52	peak
2	5939.320	18.98	42.85	61.83	68.20	-6.37	peak

Note: 1. Measurement = Reading Level + Correct Factor.
 2. If Peak Result complies with AV limit, AV Result is deemed to comply with AV limit.
 3. Peak: Peak detector.
 4. Only the worst data was recorded, if it complies with the limit, the other emissions deemed to comply with the limit.

Note: All the modes and antennas had been tested, but only the worst data was recorded in the report.

Note: Both horizontal and vertical had been tested, but only the worst data was recorded in the report.



8.2. SPURIOUS EMISSIONS (1 GHz ~ 7 GHz)

8.2.1. 5G SRD 1.4MHz MODE

UNII-3 BAND

TEST RESULTS (WORST CASE)

HARMONICS AND SPURIOUS EMISSIONS (LOW CHANNEL, HORIZONTAL)

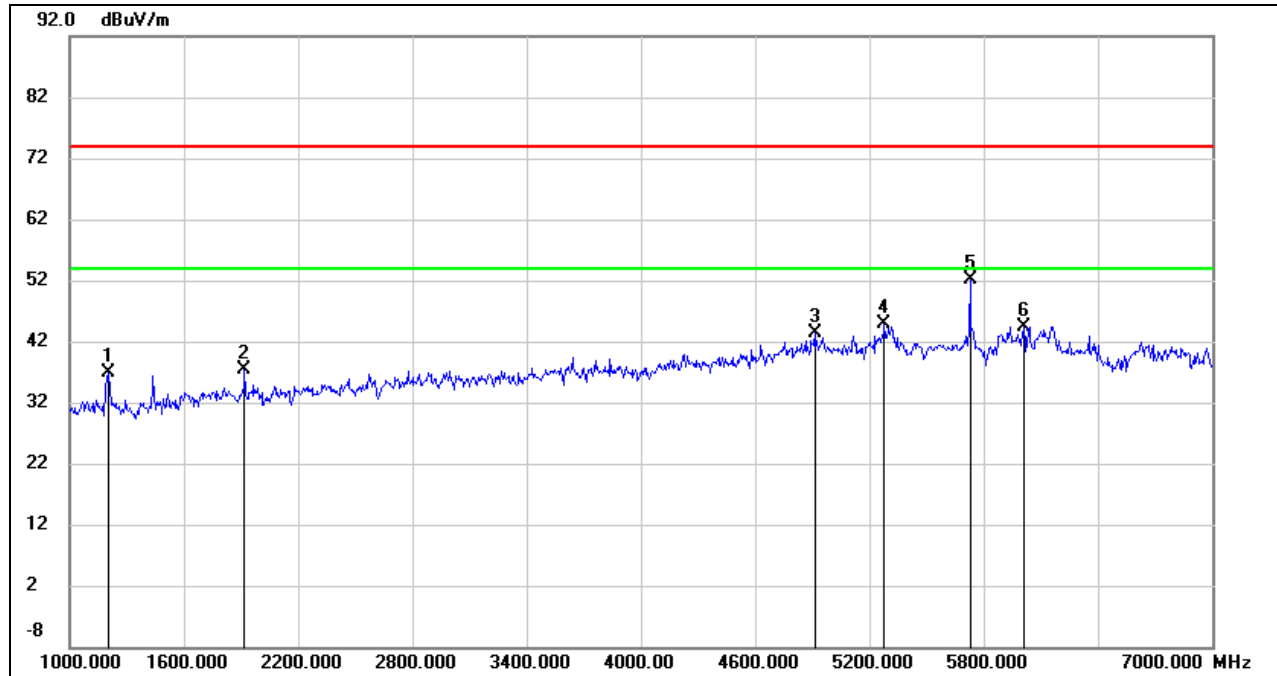

No.	Frequency (MHz)	Reading (dBuV)	Correct (dB/m)	Result (dBuV/m)	Limit (dBuV/m)	Margin (dB)	Remark
1	1204.000	49.76	-12.98	36.78	74.00	-37.22	peak
2	1918.000	47.42	-10.13	37.29	74.00	-36.71	peak
3	4912.000	42.49	0.77	43.26	74.00	-30.74	peak
4	5278.000	42.99	2.01	45.00	74.00	-29.00	peak
5	5728.000	49.66	2.49	52.15	74.00	-21.85	peak
6	6010.000	41.18	3.31	44.49	74.00	-29.51	peak

- Note:
1. Measurement = Reading Level + Correct Factor.
 2. If Peak Result complies with AV limit, AV Result is deemed to comply with AV limit.
 3. Peak: Peak detector.
 4. AVG: $VBW=1/Ton$, where: Ton is the transmitting duration.
 5. For the transmitting duration, please refer to clause 7.1.
 6. Filter losses were only considered in the spurious frequency bands and the authorized band was not corrected for Band reject filter losses.
 7. Proper operation of the transmitter prior to adding the filter to the measurement chain.
 8. Since non-restricted band peak emissions are less than the average limit, they also comply with the -27dBm/MHz (68.2dBuV/m) limit.

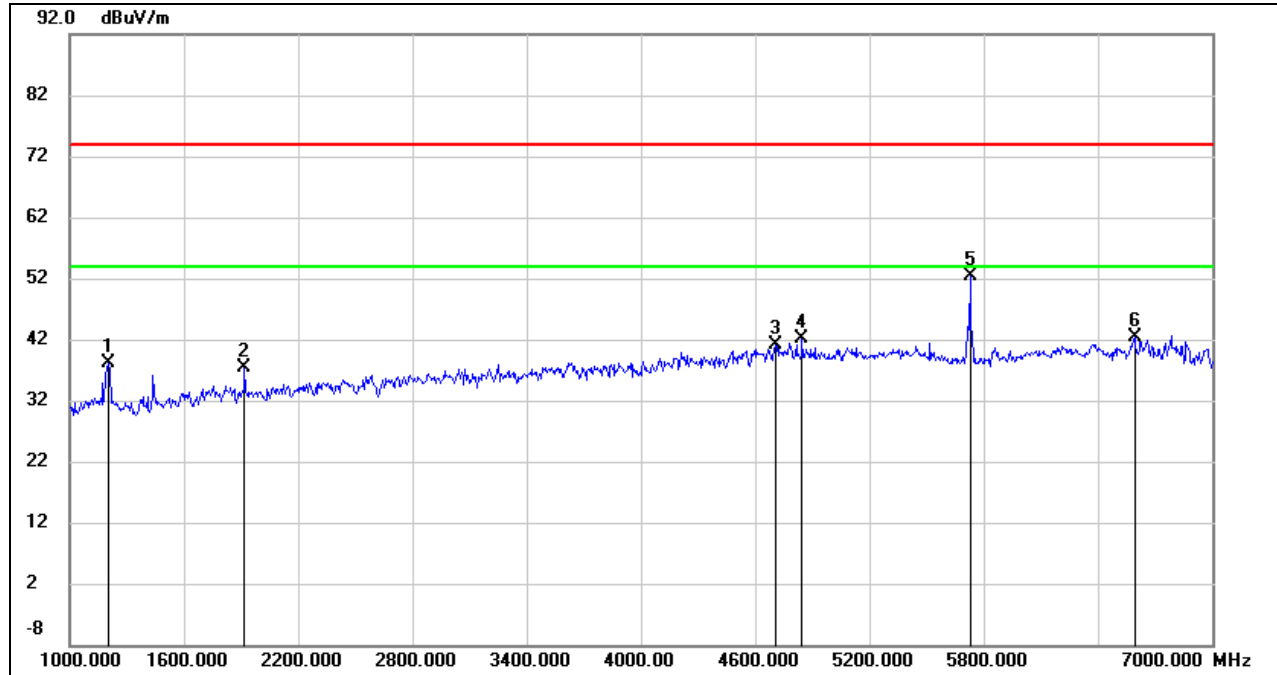
**HARMONICS AND SPURIOUS EMISSIONS (LOW CHANNEL, VERTICAL)**

No.	Frequency (MHz)	Reading (dBuV)	Correct (dB/m)	Result (dBuV/m)	Limit (dBuV/m)	Margin (dB)	Remark
1	1204.000	51.14	-12.98	38.16	74.00	-35.84	peak
2	1918.000	47.43	-10.13	37.30	74.00	-36.70	peak
3	4708.000	41.04	0.06	41.10	74.00	-32.90	peak
4	4846.000	41.42	0.66	42.08	74.00	-31.92	peak
5	5728.000	49.86	2.49	52.35	74.00	-21.65	peak
6	6592.000	36.94	5.45	42.39	74.00	-31.61	peak

- Note:
1. Measurement = Reading Level + Correct Factor.
 2. If Peak Result complies with AV limit, AV Result is deemed to comply with AV limit.
 3. Peak: Peak detector.
 4. AVG: $VBW=1/Ton$, where: Ton is the transmitting duration.
 5. For the transmitting duration, please refer to clause 7.1.
 6. Filter losses were only considered in the spurious frequency bands and the authorized band was not corrected for Band reject filter losses.
 7. Proper operation of the transmitter prior to adding the filter to the measurement chain.
 8. Since non-restricted band peak emissions are less than the average limit, they also comply with the -27dBm/MHz (68.2dBuV/m) limit.

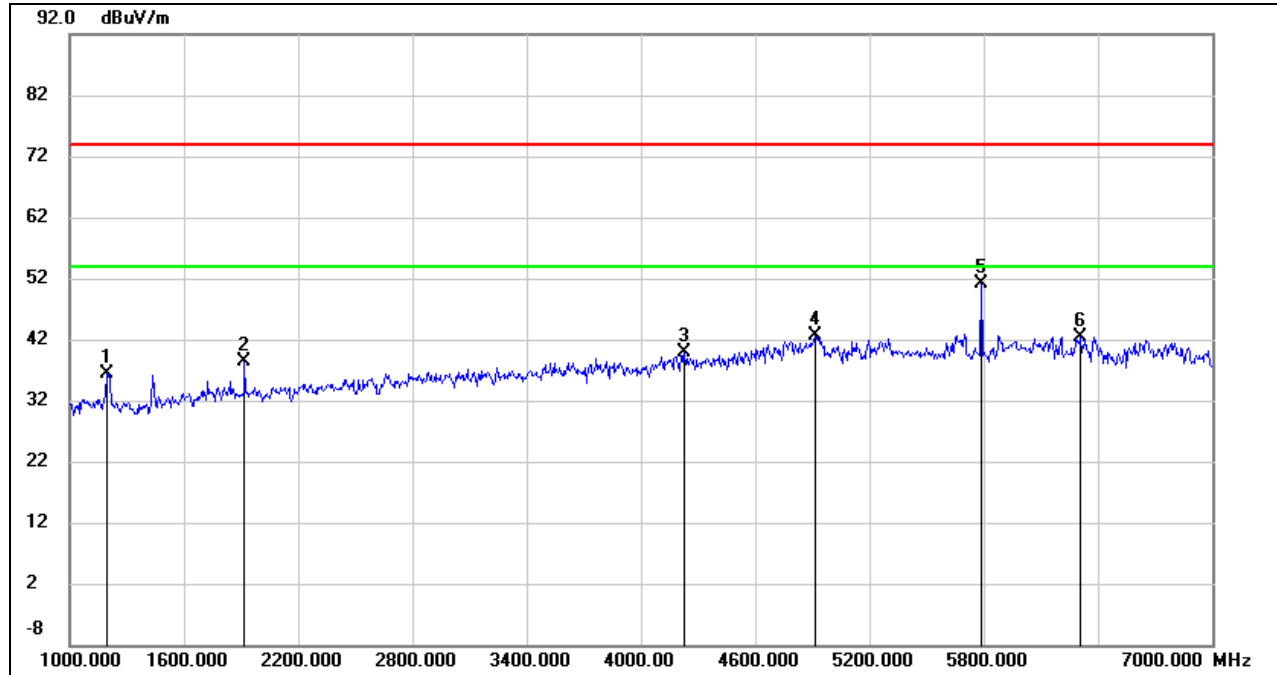
**HARMONICS AND SPURIOUS EMISSIONS (MID CHANNEL, HORIZONTAL)**

No.	Frequency (MHz)	Reading (dBuV)	Correct (dB/m)	Result (dBuV/m)	Limit (dBuV/m)	Margin (dB)	Remark
1	1198.000	49.36	-13.00	36.36	74.00	-37.64	peak
2	1918.000	48.47	-10.13	38.34	74.00	-35.66	peak
3	4228.000	41.69	-1.70	39.99	74.00	-34.01	peak
4	4912.000	41.98	0.77	42.75	74.00	-31.25	peak
5	5788.000	48.53	2.50	51.03	74.00	-22.97	peak
6	6310.000	38.60	3.87	42.47	74.00	-31.53	peak

- Note:
1. Measurement = Reading Level + Correct Factor.
 2. If Peak Result complies with AV limit, AV Result is deemed to comply with AV limit.
 3. Peak: Peak detector.
 4. AVG: $VBW=1/Ton$, where: Ton is the transmitting duration.
 5. For the transmitting duration, please refer to clause 7.1.
 6. Filter losses were only considered in the spurious frequency bands and the authorized band was not corrected for Band reject filter losses.
 7. Proper operation of the transmitter prior to adding the filter to the measurement chain.
 8. Since non-restricted band peak emissions are less than the average limit, they also comply with the -27dBm/MHz (68.2dBuV/m) limit.

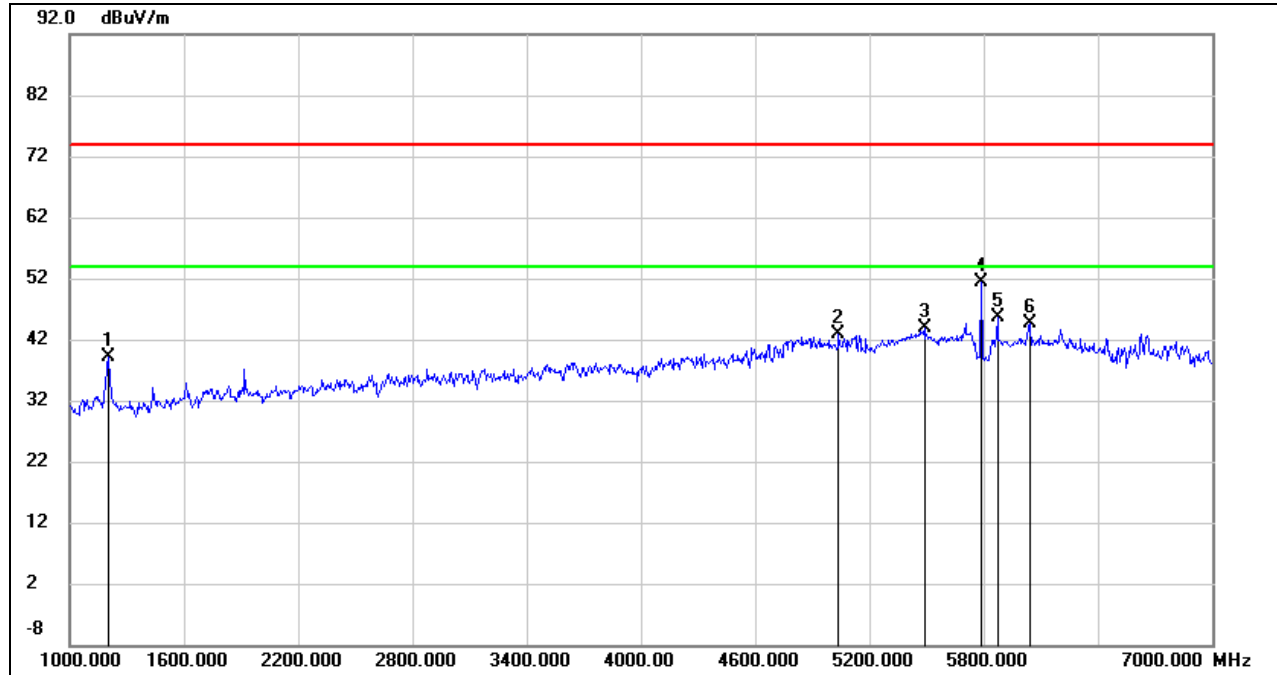
**HARMONICS AND SPURIOUS EMISSIONS (MID CHANNEL, VERTICAL)**

No.	Frequency (MHz)	Reading (dBuV)	Correct (dB/m)	Result (dBuV/m)	Limit (dBuV/m)	Margin (dB)	Remark
1	1204.000	52.00	-12.98	39.02	74.00	-34.98	peak
2	5038.000	41.82	1.13	42.95	74.00	-31.05	peak
3	5488.000	41.72	2.13	43.85	74.00	-30.15	peak
4	5788.000	49.00	2.50	51.50	74.00	-22.50	peak
5	5872.000	42.76	2.80	45.56	74.00	-28.44	peak
6	6040.000	41.26	3.28	44.54	74.00	-29.46	peak

Note: 1. Measurement = Reading Level + Correct Factor.

2. If Peak Result complies with AV limit, AV Result is deemed to comply with AV limit.

3. Peak: Peak detector.

4. AVG: $VBW=1/Ton$, where: Ton is the transmitting duration.

5. For the transmitting duration, please refer to clause 7.1.

6. Filter losses were only considered in the spurious frequency bands and the authorized band was not corrected for Band reject filter losses.

7. Proper operation of the transmitter prior to adding the filter to the measurement chain.

8. Since non-restricted band peak emissions are less than the average limit, they also comply with the -27dBm/MHz (68.2dBuV/m) limit.

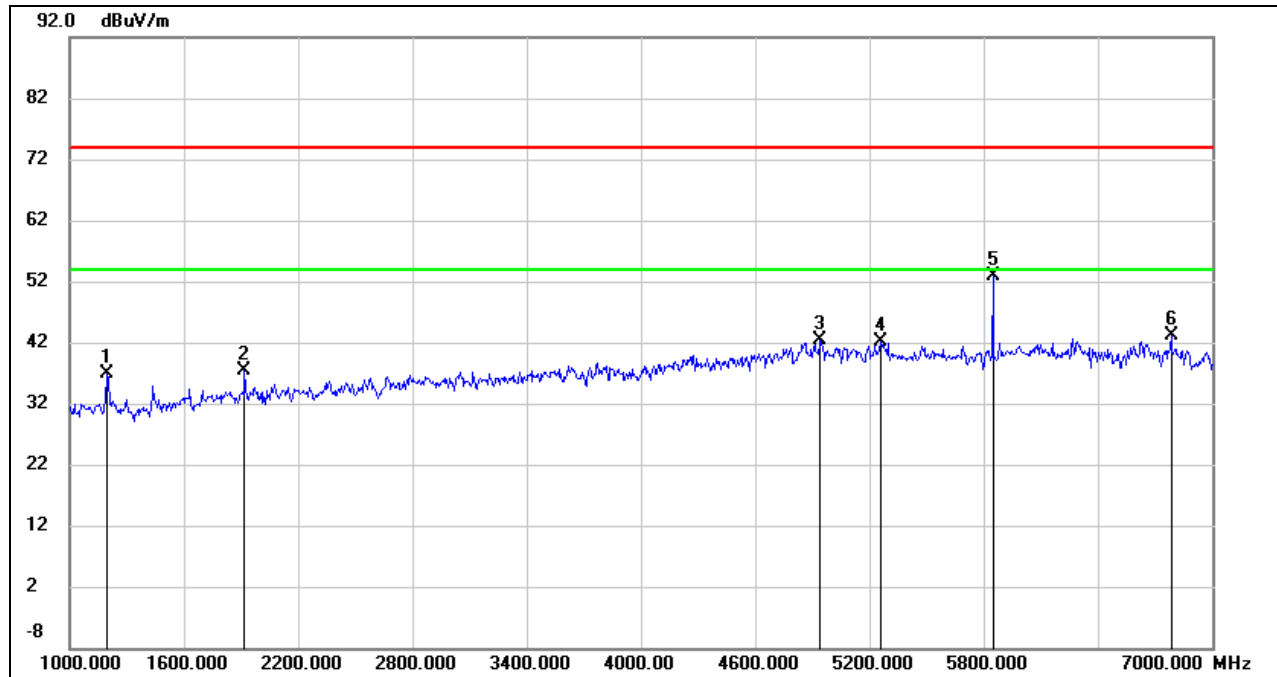
**HARMONICS AND SPURIOUS EMISSIONS (HIGH CHANNEL, HORIZONTAL)**

No.	Frequency (MHz)	Reading (dBuV)	Correct (dB/m)	Result (dBuV/m)	Limit (dBuV/m)	Margin (dB)	Remark
1	1198.000	49.92	-13.00	36.92	74.00	-37.08	peak
2	1918.000	47.49	-10.13	37.36	74.00	-36.64	peak
3	4942.000	41.54	0.81	42.35	74.00	-31.65	peak
4	5260.000	40.13	2.03	42.16	74.00	-31.84	peak
5	5848.000	50.13	2.70	52.83	74.00	-21.17	peak
6	6784.000	37.65	5.56	43.21	74.00	-30.79	peak

Note: 1. Measurement = Reading Level + Correct Factor.

2. If Peak Result complies with AV limit, AV Result is deemed to comply with AV limit.

3. Peak: Peak detector.

4. AVG: $VBW=1/Ton$, where: Ton is the transmitting duration.

5. For the transmitting duration, please refer to clause 7.1.

6. Filter losses were only considered in the spurious frequency bands and the authorized band was not corrected for Band reject filter losses.

7. Proper operation of the transmitter prior to adding the filter to the measurement chain.

8. Since non-restricted band peak emissions are less than the average limit, they also comply with the $-27dBm/MHz$ ($68.2dBuV/m$) limit.

HARMONICS AND SPURIOUS EMISSIONS (HIGH CHANNEL, VERTICAL)

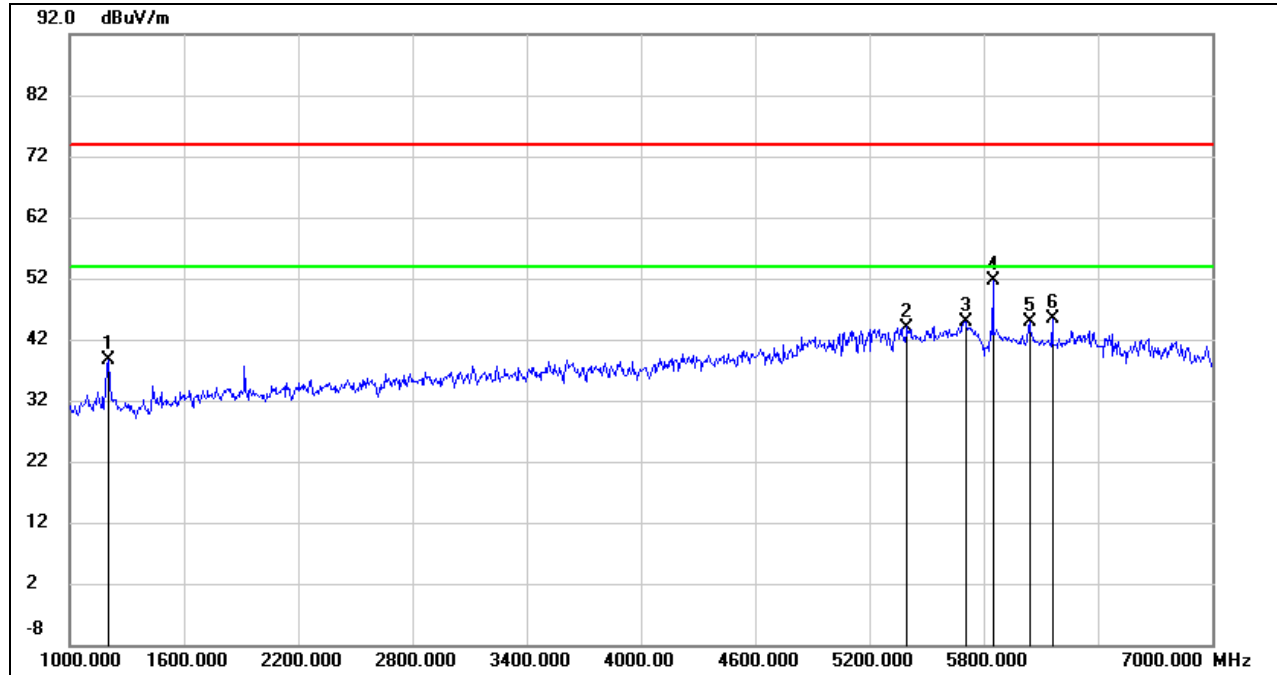

No.	Frequency (MHz)	Reading (dBuV)	Correct (dB/m)	Result (dBuV/m)	Limit (dBuV/m)	Margin (dB)	Remark
1	1204.000	51.59	-12.98	38.61	74.00	-35.39	peak
2	5398.000	42.12	1.88	44.00	74.00	-30.00	peak
3	5704.000	42.48	2.48	44.96	74.00	-29.04	peak
4	5848.000	48.88	2.70	51.58	74.00	-22.42	peak
5	6040.000	41.68	3.28	44.96	74.00	-29.04	peak
6	6160.000	42.20	3.27	45.47	74.00	-28.53	peak

- Note:
1. Measurement = Reading Level + Correct Factor.
 2. If Peak Result complies with AV limit, AV Result is deemed to comply with AV limit.
 3. Peak: Peak detector.
 4. AVG: $VBW=1/Ton$, where: Ton is the transmitting duration.
 5. For the transmitting duration, please refer to clause 7.1.
 6. Filter losses were only considered in the spurious frequency bands and the authorized band was not corrected for Band reject filter losses.
 7. Proper operation of the transmitter prior to adding the filter to the measurement chain.
 8. Since non-restricted band peak emissions are less than the average limit, they also comply with the -27dBm/MHz (68.2dBuV/m) limit.

Note: All the modes and antennas had been tested, but only the worst data was recorded in the report.



8.3. SPURIOUS EMISSIONS (7 GHz ~ 18 GHz)

8.3.1. 5G SRD 1.4MHz MODE

UNII-3 BAND

HARMONICS AND SPURIOUS EMISSIONS (LOW CHANNEL, HORIZONTAL)

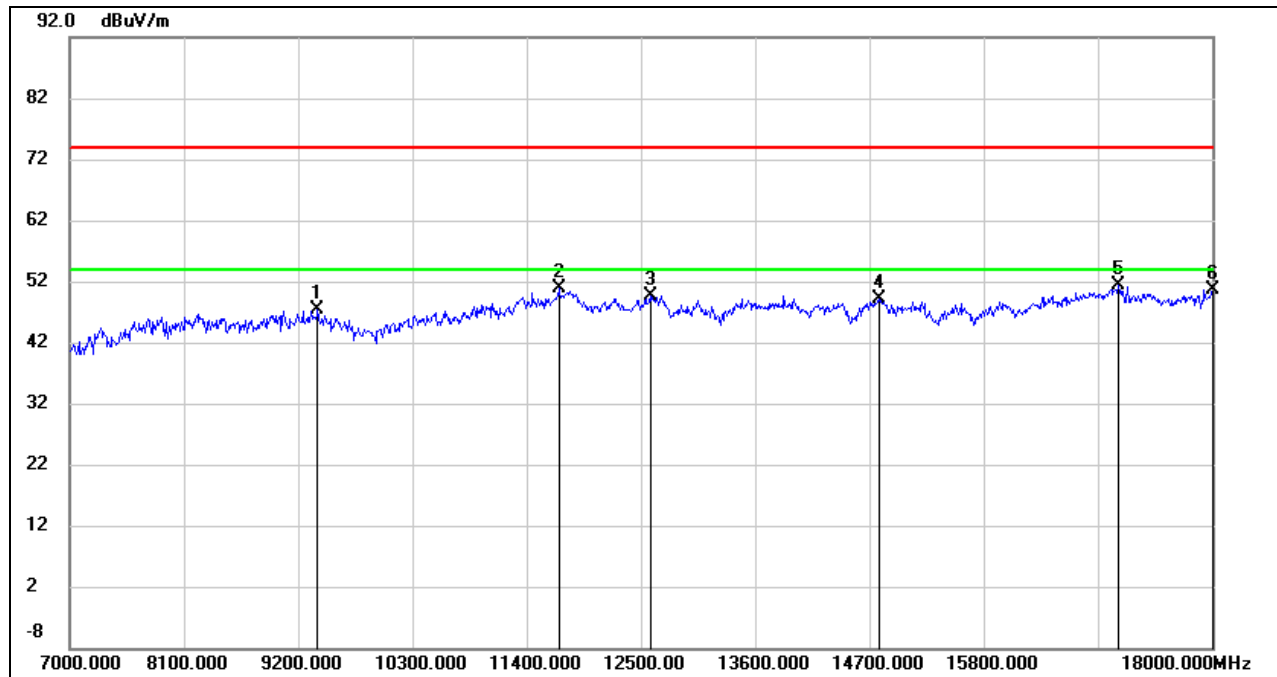

No.	Frequency (MHz)	Reading (dBuV)	Correct (dB/m)	Result (dBuV/m)	Limit (dBuV/m)	Margin (dB)	Remark
1	9387.000	37.14	10.24	47.38	74.00	-26.62	peak
2	11708.000	35.66	15.11	50.77	74.00	-23.23	peak
3	12588.000	34.31	15.29	49.60	74.00	-24.40	peak
4	14788.000	32.37	16.78	49.15	74.00	-24.85	peak
5	17098.000	30.66	20.63	51.29	74.00	-22.71	peak
6	18000.000	27.95	22.67	50.62	74.00	-23.38	peak

Note: 1. Measurement = Reading Level + Correct Factor.

2. If Peak Result complies with AV limit, AV Result is deemed to comply with AV limit.

3. Peak: Peak detector.

4. AVG: $VBW=1/Ton$, where: Ton is the transmitting duration.

5. For the transmitting duration, please refer to clause 7.1.

6. Filter losses were only considered in the spurious frequency bands and the authorized band was not corrected for High Pass Filter losses.

7. Proper operation of the transmitter prior to adding the filter to the measurement chain.

8. Since non-restricted band peak emissions are less than the average limit, they also comply with the -27dBm/MHz (68.2dBuV/m) limit.

HARMONICS AND SPURIOUS EMISSIONS (LOW CHANNEL, VERTICAL)

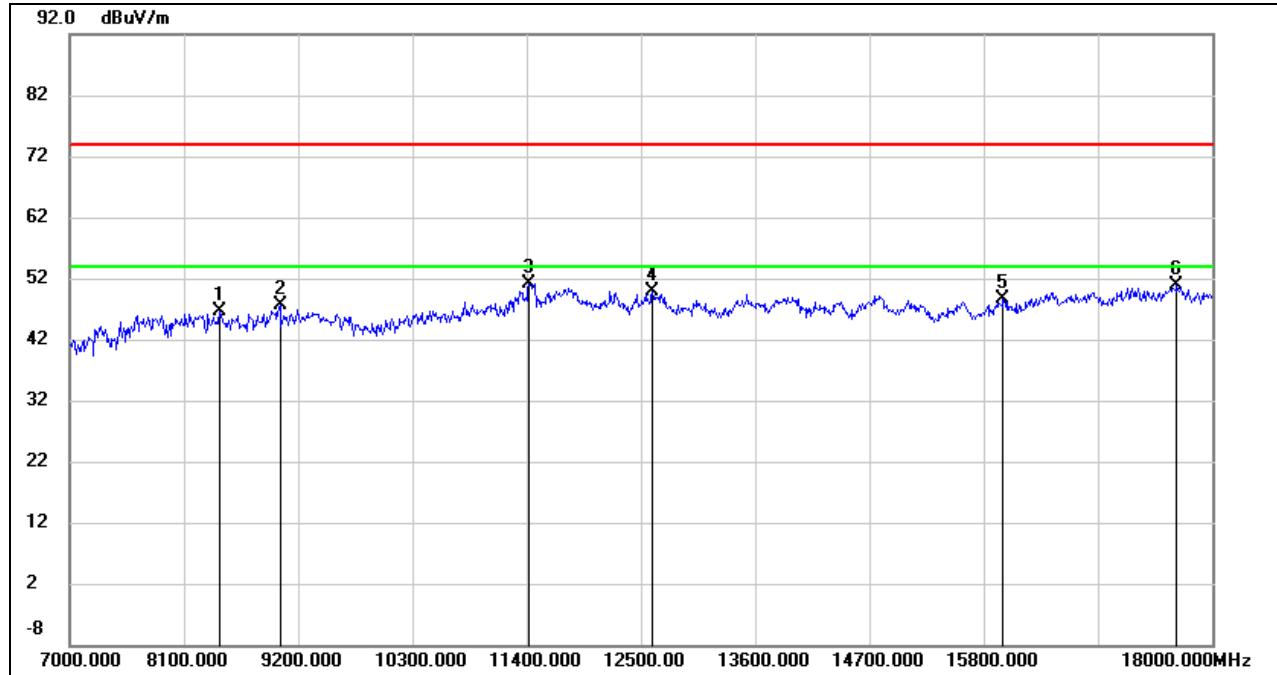

No.	Frequency (MHz)	Reading (dBuV)	Correct (dB/m)	Result (dBuV/m)	Limit (dBuV/m)	Margin (dB)	Remark
1	8441.000	38.18	8.56	46.74	74.00	-27.26	peak
2	9024.000	37.08	10.47	47.55	74.00	-26.45	peak
3	11422.000	36.93	14.25	51.18	74.00	-22.82	peak
4	12610.000	34.60	15.30	49.90	74.00	-24.10	peak
5	15987.000	31.35	17.20	48.55	74.00	-25.45	peak
6	17659.000	29.17	21.63	50.80	74.00	-23.20	peak

- Note:
1. Measurement = Reading Level + Correct Factor.
 2. If Peak Result complies with AV limit, AV Result is deemed to comply with AV limit.
 3. Peak: Peak detector.
 4. AVG: $VBW=1/Ton$, where: Ton is the transmitting duration.
 5. For the transmitting duration, please refer to clause 7.1.
 6. Filter losses were only considered in the spurious frequency bands and the authorized band was not corrected for High Pass Filter losses.
 7. Proper operation of the transmitter prior to adding the filter to the measurement chain.
 8. Since non-restricted band peak emissions are less than the average limit, they also comply with the -27dBm/MHz (68.2dBuV/m) limit.

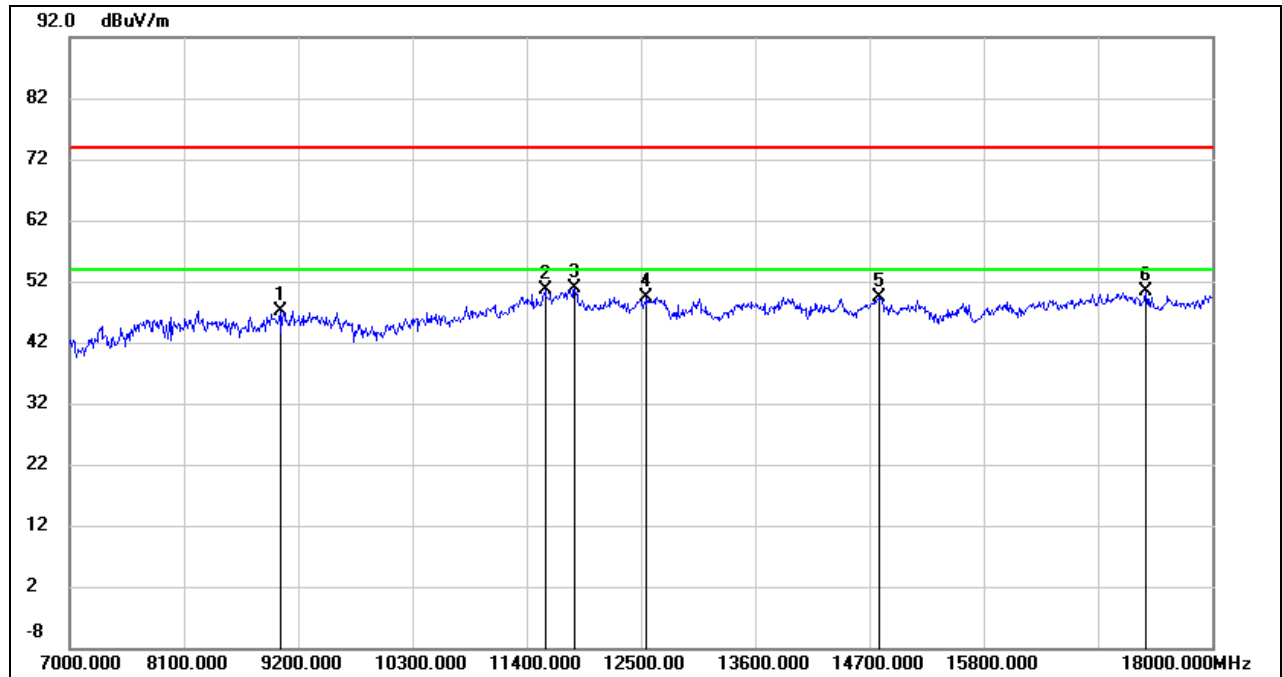
**HARMONICS AND SPURIOUS EMISSIONS (MID CHANNEL, HORIZONTAL)**

No.	Frequency (MHz)	Reading (dBuV)	Correct (dB/m)	Result (dBuV/m)	Limit (dBuV/m)	Margin (dB)	Remark
1	9024.000	36.73	10.47	47.20	74.00	-26.80	peak
2	11576.000	36.05	14.48	50.53	74.00	-23.47	peak
3	11862.000	35.27	15.52	50.79	74.00	-23.21	peak
4	12555.000	33.97	15.32	49.29	74.00	-24.71	peak
5	14788.000	32.57	16.78	49.35	74.00	-24.65	peak
6	17362.000	29.71	20.79	50.50	74.00	-23.50	peak

- Note:
1. Measurement = Reading Level + Correct Factor.
 2. If Peak Result complies with AV limit, AV Result is deemed to comply with AV limit.
 3. Peak: Peak detector.
 4. AVG: $VBW=1/Ton$, where: Ton is the transmitting duration.
 5. For the transmitting duration, please refer to clause 7.1.
 6. Filter losses were only considered in the spurious frequency bands and the authorized band was not corrected for High Pass Filter losses.
 7. Proper operation of the transmitter prior to adding the filter to the measurement chain.
 8. Since non-restricted band peak emissions are less than the average limit, they also comply with the -27dBm/MHz (68.2dBuV/m) limit.

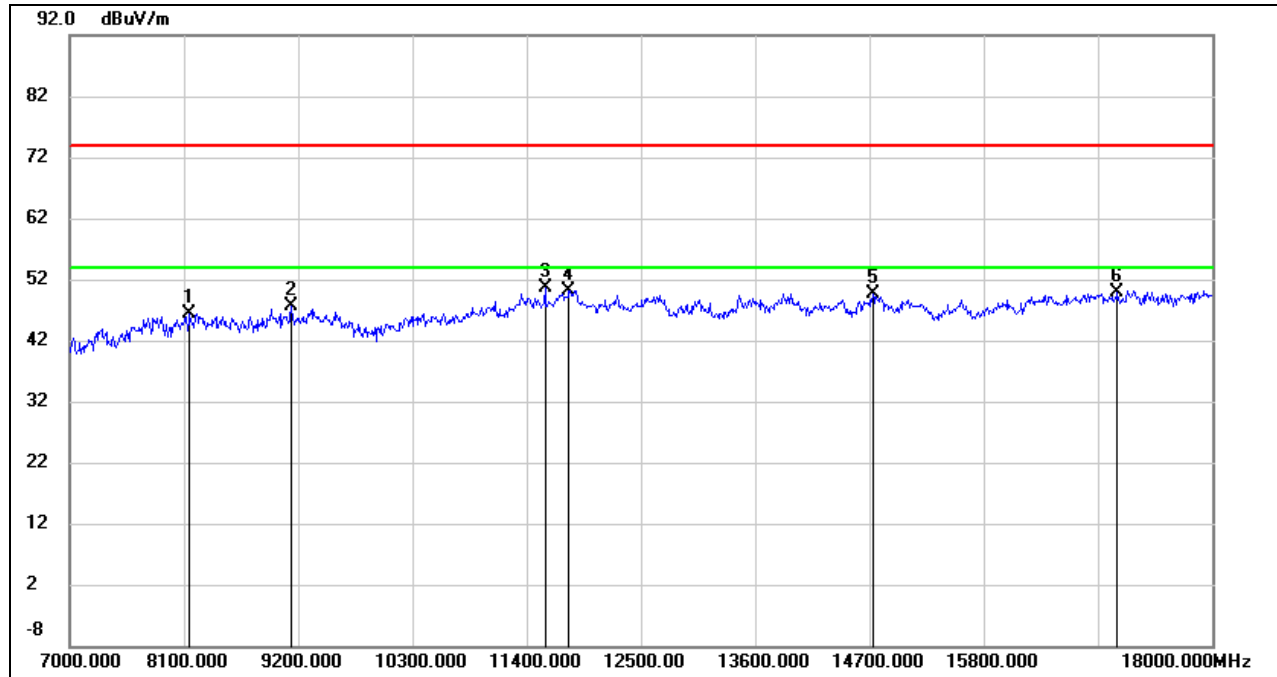
**HARMONICS AND SPURIOUS EMISSIONS (MID CHANNEL, VERTICAL)**

No.	Frequency (MHz)	Reading (dBuV)	Correct (dB/m)	Result (dBuV/m)	Limit (dBuV/m)	Margin (dB)	Remark
1	8155.000	37.47	8.98	46.45	74.00	-27.55	peak
2	9134.000	37.87	9.73	47.60	74.00	-26.40	peak
3	11576.000	36.16	14.48	50.64	74.00	-23.36	peak
4	11807.000	34.59	15.61	50.20	74.00	-23.80	peak
5	14733.000	33.05	16.69	49.74	74.00	-24.26	peak
6	17087.000	29.18	20.58	49.76	74.00	-24.24	peak

Note: 1. Measurement = Reading Level + Correct Factor.

2. If Peak Result complies with AV limit, AV Result is deemed to comply with AV limit.

3. Peak: Peak detector.

4. AVG: $VBW=1/Ton$, where: Ton is the transmitting duration.

5. For the transmitting duration, please refer to clause 7.1.

6. Filter losses were only considered in the spurious frequency bands and the authorized band was not corrected for High Pass Filter losses.

7. Proper operation of the transmitter prior to adding the filter to the measurement chain.

8. Since non-restricted band peak emissions are less than the average limit, they also comply with the -27dBm/MHz (68.2dBuV/m) limit.

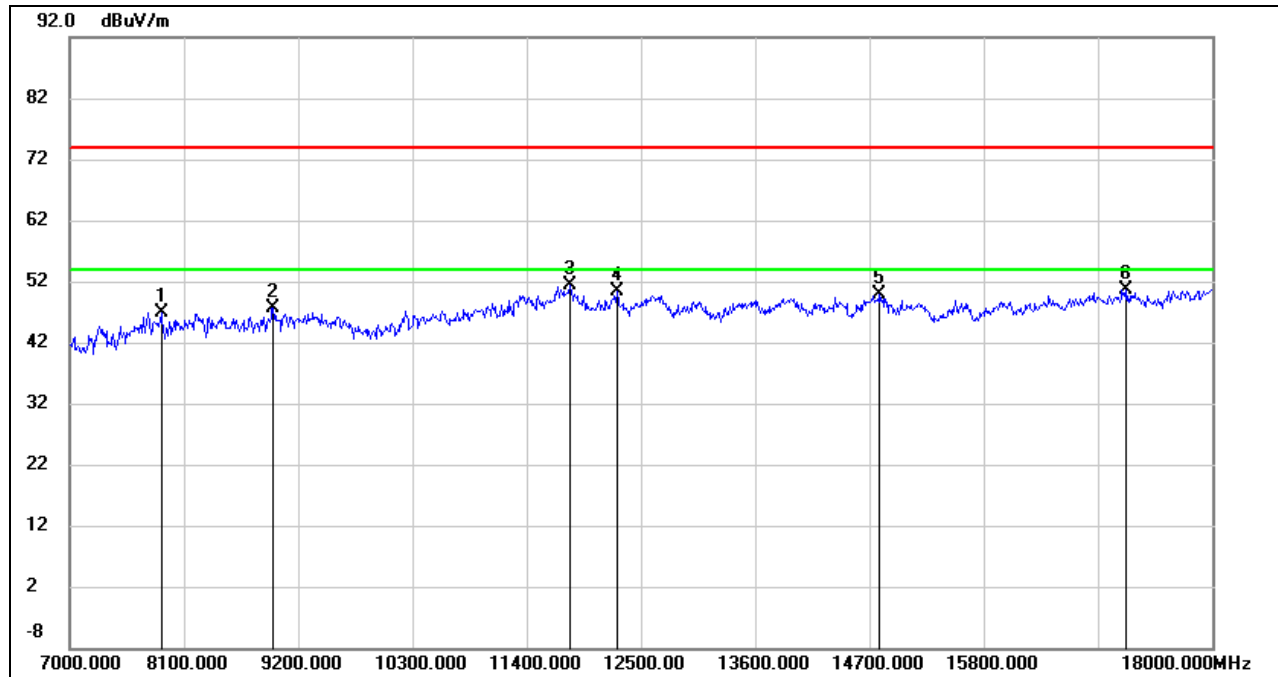
**HARMONICS AND SPURIOUS EMISSIONS (HIGH CHANNEL, HORIZONTAL)**

No.	Frequency (MHz)	Reading (dBuV)	Correct (dB/m)	Result (dBuV/m)	Limit (dBuV/m)	Margin (dB)	Remark
1	7880.000	38.77	8.01	46.78	74.00	-27.22	peak
2	8958.000	37.48	10.19	47.67	74.00	-26.33	peak
3	11818.000	35.70	15.58	51.28	74.00	-22.72	peak
4	12269.000	35.15	15.24	50.39	74.00	-23.61	peak
5	14799.000	33.05	16.80	49.85	74.00	-24.15	peak
6	17175.000	29.77	20.94	50.71	74.00	-23.29	peak

- Note:
1. Measurement = Reading Level + Correct Factor.
 2. If Peak Result complies with AV limit, AV Result is deemed to comply with AV limit.
 3. Peak: Peak detector.
 4. AVG: $VBW=1/Ton$, where: Ton is the transmitting duration.
 5. For the transmitting duration, please refer to clause 7.1.
 6. Filter losses were only considered in the spurious frequency bands and the authorized band was not corrected for High Pass Filter losses.
 7. Proper operation of the transmitter prior to adding the filter to the measurement chain.
 8. Since non-restricted band peak emissions are less than the average limit, they also comply with the -27dBm/MHz (68.2dBuV/m) limit.

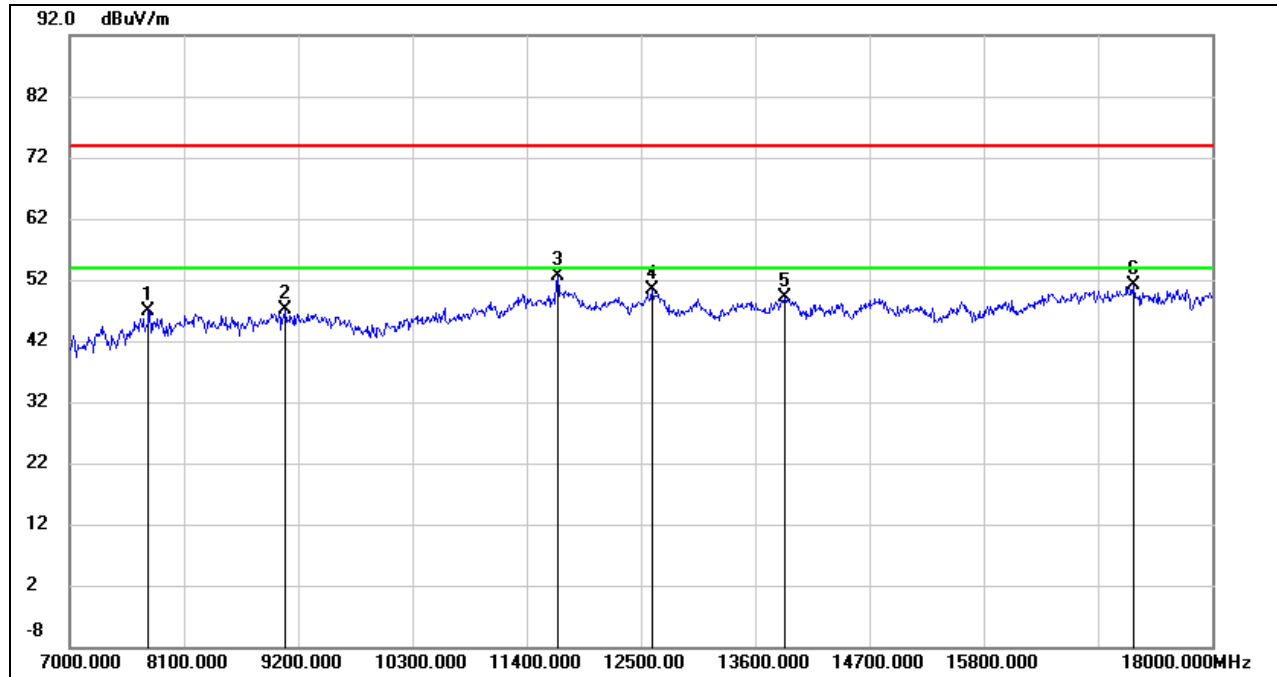
**HARMONICS AND SPURIOUS EMISSIONS (HIGH CHANNEL, VERTICAL)**

No.	Frequency (MHz)	Reading (dBuV)	Correct (dB/m)	Result (dBuV/m)	Limit (dBuV/m)	Margin (dB)	Remark
1	7759.000	38.91	8.09	47.00	74.00	-27.00	peak
2	9079.000	36.98	10.10	47.08	74.00	-26.92	QP
3	11697.000	37.51	15.05	52.56	74.00	-21.44	peak
4	12610.000	35.19	15.30	50.49	74.00	-23.51	peak
5	13886.000	32.22	16.91	49.13	74.00	-24.87	peak
6	17241.000	30.05	20.97	51.02	74.00	-22.98	peak

Note: 1. Measurement = Reading Level + Correct Factor.

2. If Peak Result complies with AV limit, AV Result is deemed to comply with AV limit.

3. Peak: Peak detector.

4. AVG: $VBW=1/Ton$, where: Ton is the transmitting duration.

5. For the transmitting duration, please refer to clause 7.1.

6. Filter losses were only considered in the spurious frequency bands and the authorized band was not corrected for High Pass Filter losses.

7. Proper operation of the transmitter prior to adding the filter to the measurement chain.

8. Since non-restricted band peak emissions are less than the average limit, they also comply with the -27dBm/MHz (68.2dBuV/m) limit.

8.3.2. 5G SRD 1.4MHz CA MODE

UNII-3 BAND

HARMONICS AND SPURIOUS EMISSIONS (LOW CHANNEL, HORIZONTAL)

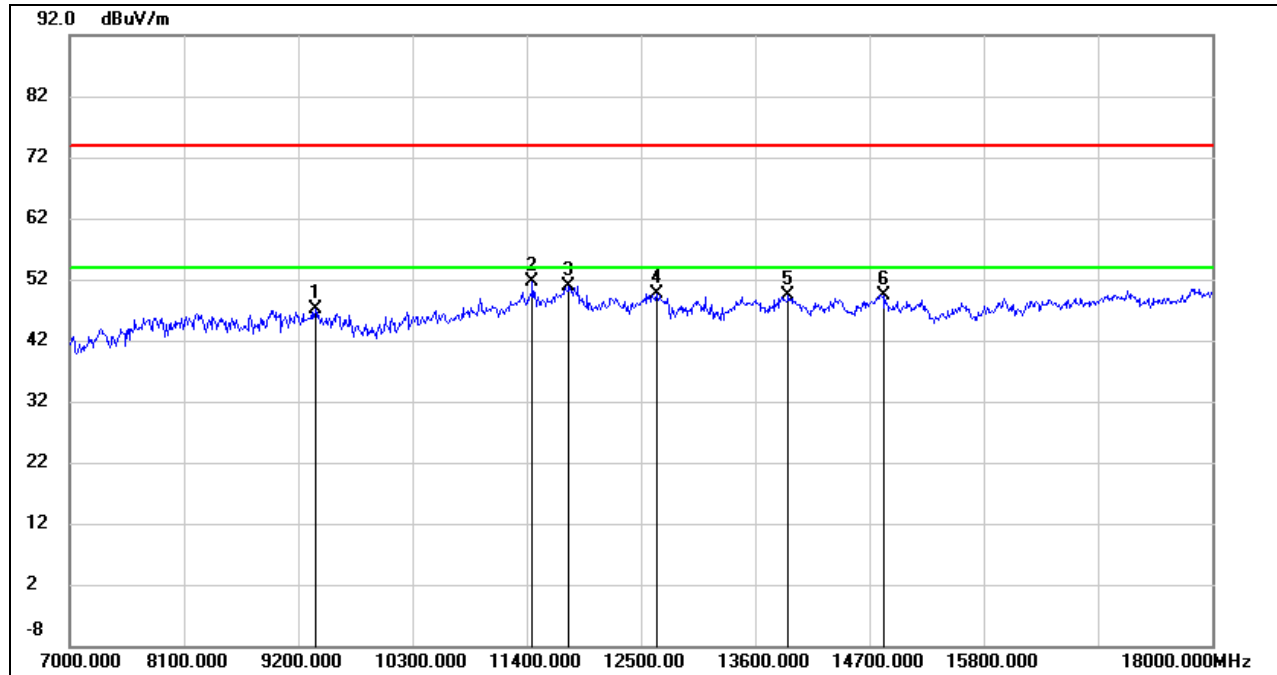

No.	Frequency (MHz)	Reading (dBuV)	Correct (dB/m)	Result (dBuV/m)	Limit (dBuV/m)	Margin (dB)	Remark
1	9365.000	36.93	10.13	47.06	74.00	-26.94	peak
2	11455.000	37.24	14.29	51.53	74.00	-22.47	peak
3	11807.000	35.39	15.61	51.00	74.00	-23.00	peak
4	12654.000	34.17	15.38	49.55	74.00	-24.45	peak
5	13919.000	32.58	16.89	49.47	74.00	-24.53	peak
6	14832.000	32.55	16.82	49.37	74.00	-24.63	peak

- Note: 1. Measurement = Reading Level + Correct Factor.
 2. If Peak Result complies with AV limit, AV Result is deemed to comply with AV limit.
 3. Peak: Peak detector.
 4. AVG: $VBW=1/Ton$, where: Ton is the transmitting duration.
 5. For the transmitting duration, please refer to clause 7.1.
 6. Filter losses were only considered in the spurious frequency bands and the authorized band was not corrected for High Pass Filter losses.
 7. Proper operation of the transmitter prior to adding the filter to the measurement chain.
 8. Since non-restricted band peak emissions are less than the average limit, they also comply with the -27dBm/MHz (68.2dBuV/m) limit.

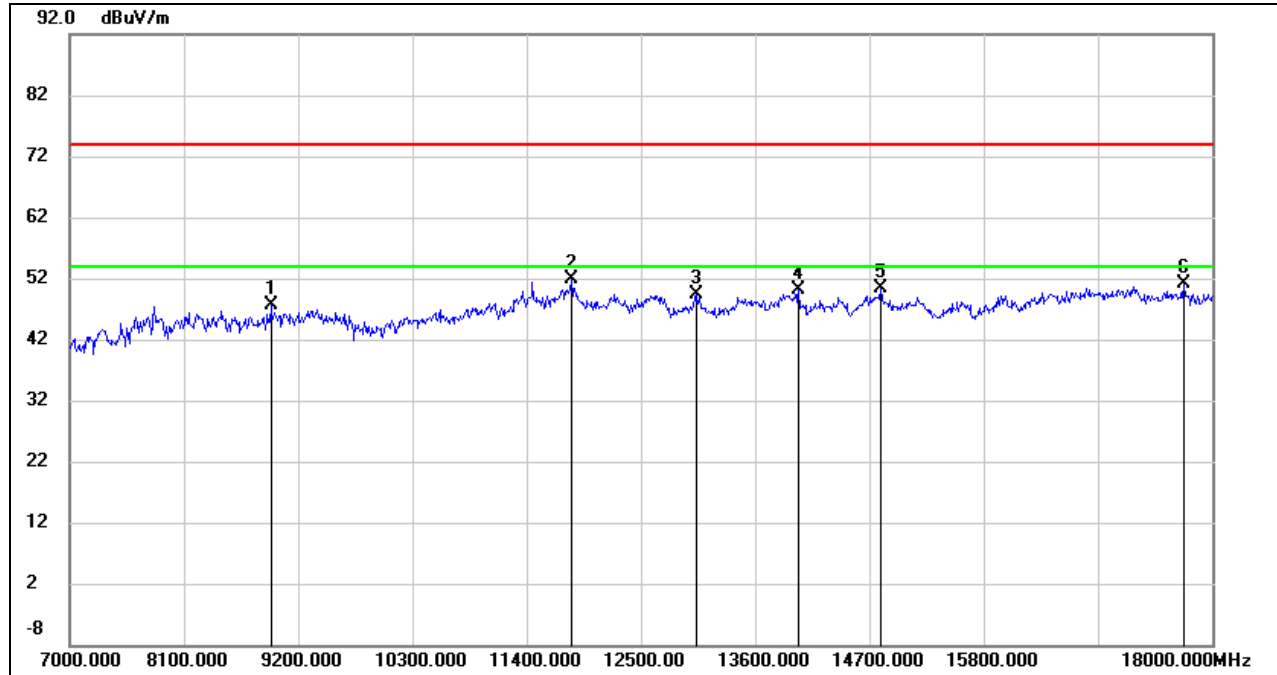
**HARMONICS AND SPURIOUS EMISSIONS (LOW CHANNEL, VERTICAL)**

No.	Frequency (MHz)	Reading (dBuV)	Correct (dB/m)	Result (dBuV/m)	Limit (dBuV/m)	Margin (dB)	Remark
1	8936.000	37.64	9.96	47.60	74.00	-26.40	peak
2	11829.000	36.27	15.57	51.84	74.00	-22.16	peak
3	13039.000	34.03	15.45	49.48	74.00	-24.52	peak
4	14018.000	33.29	16.84	50.13	74.00	-23.87	peak
5	14810.000	33.47	16.80	50.27	74.00	-23.73	peak
6	17725.000	28.96	22.13	51.09	74.00	-22.91	peak

Note: 1. Measurement = Reading Level + Correct Factor.

2. If Peak Result complies with AV limit, AV Result is deemed to comply with AV limit.

3. Peak: Peak detector.

4. AVG: $VBW=1/Ton$, where: Ton is the transmitting duration.

5. For the transmitting duration, please refer to clause 7.1.

6. Filter losses were only considered in the spurious frequency bands and the authorized band was not corrected for High Pass Filter losses.

7. Proper operation of the transmitter prior to adding the filter to the measurement chain.

8. Since non-restricted band peak emissions are less than the average limit, they also comply with the -27dBm/MHz (68.2dBuV/m) limit.

HARMONICS AND SPURIOUS EMISSIONS (MID CHANNEL, HORIZONTAL)

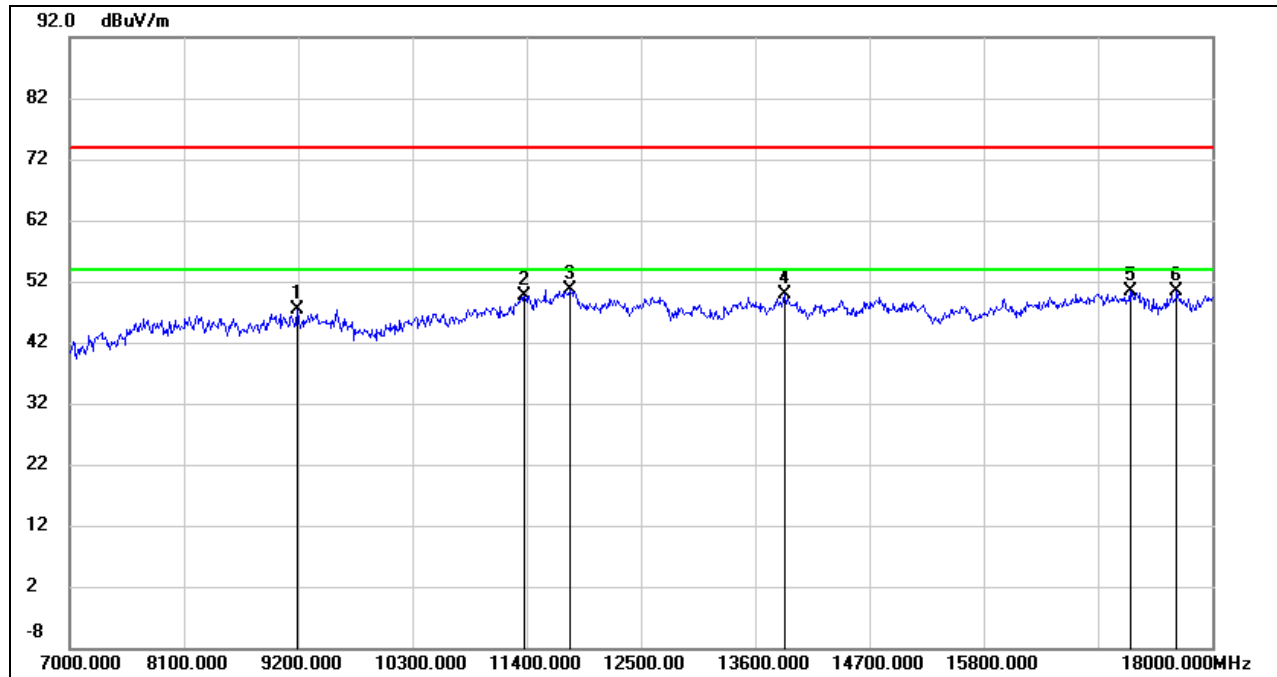

No.	Frequency (MHz)	Reading (dBuV)	Correct (dB/m)	Result (dBuV/m)	Limit (dBuV/m)	Margin (dB)	Remark
1	9189.000	38.05	9.36	47.41	74.00	-26.59	peak
2	11378.000	35.58	14.15	49.73	74.00	-24.27	peak
3	11818.000	34.99	15.58	50.57	74.00	-23.43	peak
4	13886.000	32.88	16.91	49.79	74.00	-24.21	peak
5	17208.000	29.30	21.03	50.33	74.00	-23.67	peak
6	17659.000	28.79	21.63	50.42	74.00	-23.58	peak

- Note:
1. Measurement = Reading Level + Correct Factor.
 2. If Peak Result complies with AV limit, AV Result is deemed to comply with AV limit.
 3. Peak: Peak detector.
 4. AVG: $VBW=1/Ton$, where: Ton is the transmitting duration.
 5. For the transmitting duration, please refer to clause 7.1.
 6. Filter losses were only considered in the spurious frequency bands and the authorized band was not corrected for High Pass Filter losses.
 7. Proper operation of the transmitter prior to adding the filter to the measurement chain.
 8. Since non-restricted band peak emissions are less than the average limit, they also comply with the -27dBm/MHz (68.2dBuV/m) limit.

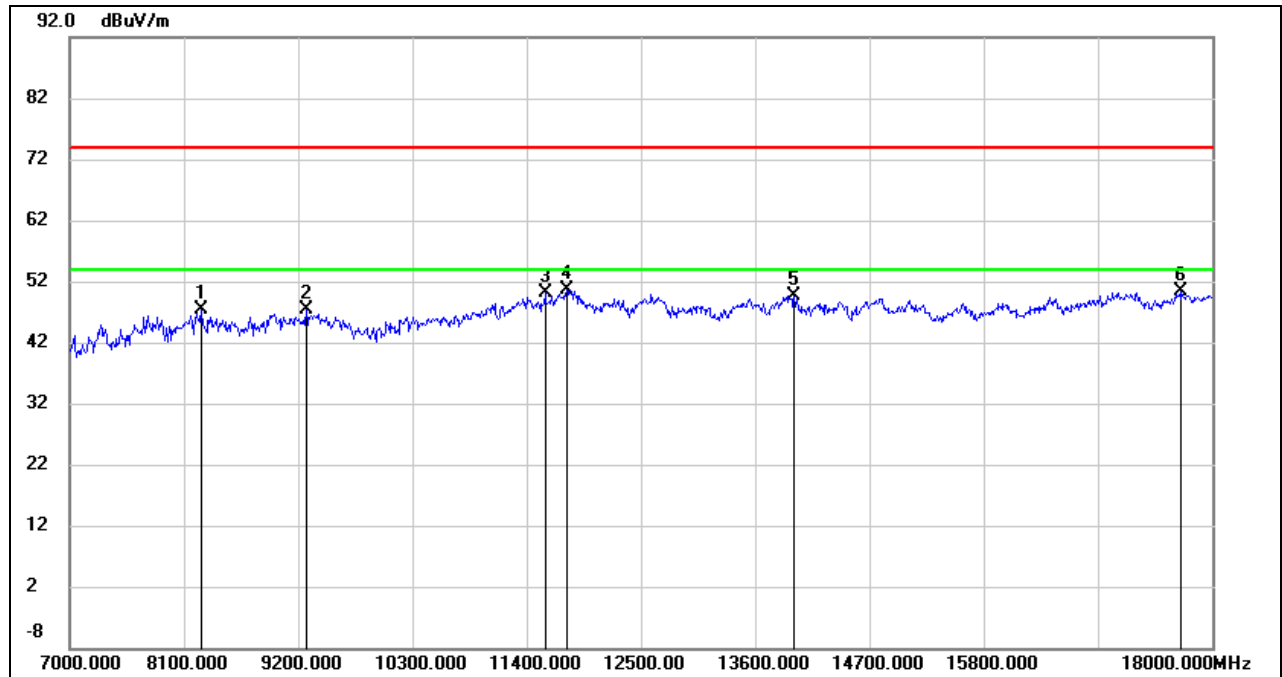
**HARMONICS AND SPURIOUS EMISSIONS (MID CHANNEL, VERTICAL)**

No.	Frequency (MHz)	Reading (dBuV)	Correct (dB/m)	Result (dBuV/m)	Limit (dBuV/m)	Margin (dB)	Remark
1	8265.000	38.17	9.11	47.28	74.00	-26.72	peak
2	9277.000	37.64	9.67	47.31	74.00	-26.69	peak
3	11576.000	35.75	14.48	50.23	74.00	-23.77	peak
4	11785.000	35.23	15.52	50.75	74.00	-23.25	peak
5	13974.000	32.86	16.86	49.72	74.00	-24.28	peak
6	17703.000	28.52	21.96	50.48	74.00	-23.52	peak

Note: 1. Measurement = Reading Level + Correct Factor.

2. If Peak Result complies with AV limit, AV Result is deemed to comply with AV limit.

3. Peak: Peak detector.

4. AVG: $VBW=1/Ton$, where: Ton is the transmitting duration.

5. For the transmitting duration, please refer to clause 7.1.

6. Filter losses were only considered in the spurious frequency bands and the authorized band was not corrected for High Pass Filter losses.

7. Proper operation of the transmitter prior to adding the filter to the measurement chain.

8. Since non-restricted band peak emissions are less than the average limit, they also comply with the -27dBm/MHz (68.2dBuV/m) limit.

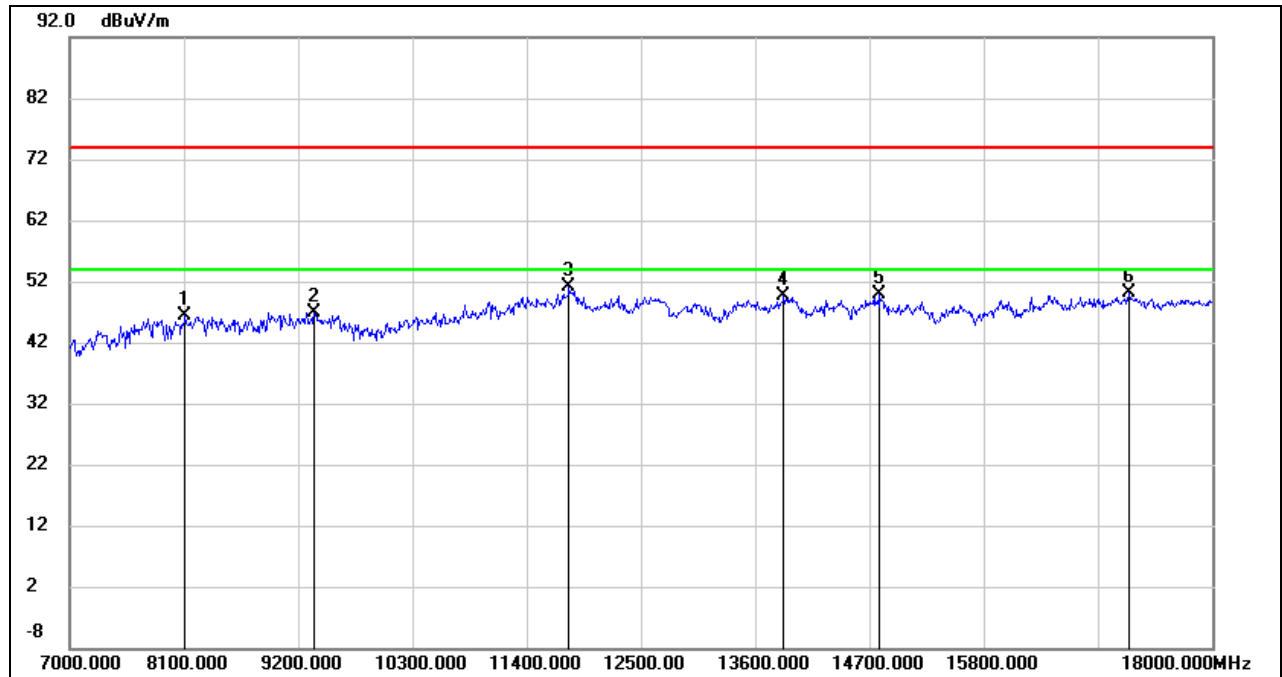
**HARMONICS AND SPURIOUS EMISSIONS (HIGH CHANNEL, HORIZONTAL)**

No.	Frequency (MHz)	Reading (dBuV)	Correct (dB/m)	Result (dBuV/m)	Limit (dBuV/m)	Margin (dB)	Remark
1	8111.000	37.84	8.61	46.45	74.00	-27.55	peak
2	9354.000	36.80	10.07	46.87	74.00	-27.13	peak
3	11807.000	35.48	15.61	51.09	74.00	-22.91	peak
4	13875.000	32.75	16.92	49.67	74.00	-24.33	peak
5	14799.000	33.10	16.80	49.90	74.00	-24.10	peak
6	17197.000	29.19	21.03	50.22	74.00	-23.78	peak

Note: 1. Measurement = Reading Level + Correct Factor.

2. If Peak Result complies with AV limit, AV Result is deemed to comply with AV limit.

3. Peak: Peak detector.

4. AVG: $VBW=1/Ton$, where: Ton is the transmitting duration.

5. For the transmitting duration, please refer to clause 7.1.

6. Filter losses were only considered in the spurious frequency bands and the authorized band was not corrected for High Pass Filter losses.

7. Proper operation of the transmitter prior to adding the filter to the measurement chain.

8. Since non-restricted band peak emissions are less than the average limit, they also comply with the -27dBm/MHz (68.2dBuV/m) limit.

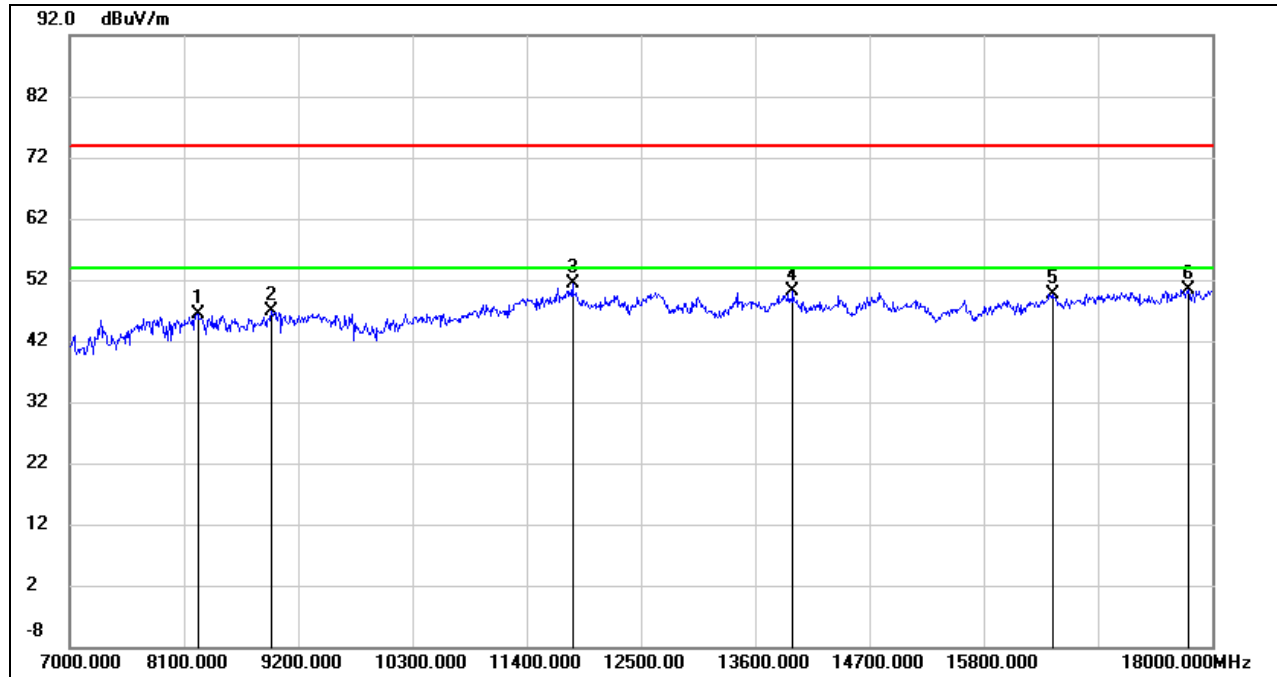
**HARMONICS AND SPURIOUS EMISSIONS (HIGH CHANNEL, VERTICAL)**

No.	Frequency (MHz)	Reading (dBuV)	Correct (dB/m)	Result (dBuV/m)	Limit (dBuV/m)	Margin (dB)	Remark
1	8232.000	37.24	9.23	46.47	74.00	-27.53	peak
2	8936.000	36.80	9.96	46.76	74.00	-27.24	peak
3	11840.000	35.71	15.56	51.27	74.00	-22.73	peak
4	13963.000	33.38	16.87	50.25	74.00	-23.75	peak
5	16460.000	30.68	18.96	49.64	74.00	-24.36	peak
6	17769.000	27.87	22.48	50.35	74.00	-23.65	peak

- Note:
1. Measurement = Reading Level + Correct Factor.
 2. If Peak Result complies with AV limit, AV Result is deemed to comply with AV limit.
 3. Peak: Peak detector.
 4. AVG: $VBW=1/Ton$, where: Ton is the transmitting duration.
 5. For the transmitting duration, please refer to clause 7.1.
 6. Filter losses were only considered in the spurious frequency bands and the authorized band was not corrected for High Pass Filter losses.
 7. Proper operation of the transmitter prior to adding the filter to the measurement chain.
 8. Since non-restricted band peak emissions are less than the average limit, they also comply with the -27dBm/MHz (68.2dBuV/m) limit.

8.3.3. 5G SRD 3MHz MODE

UNII-3 BAND

HARMONICS AND SPURIOUS EMISSIONS (LOW CHANNEL, HORIZONTAL)

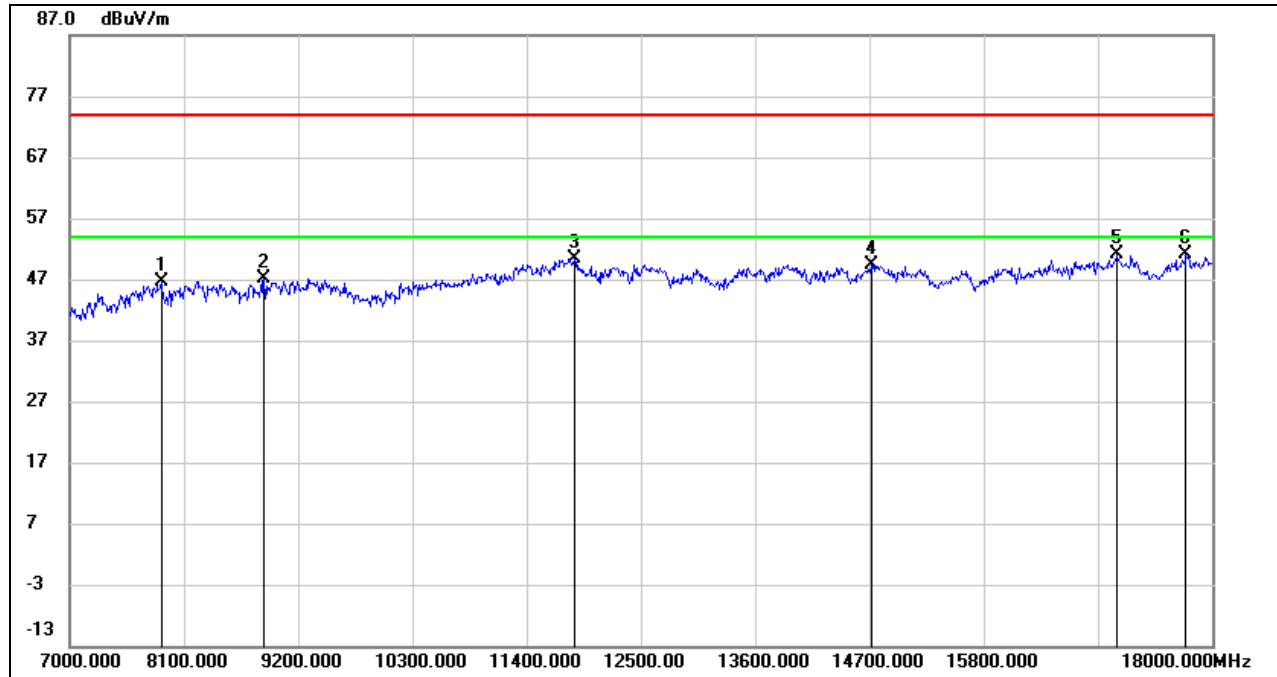

No.	Frequency (MHz)	Reading (dBuV)	Correct (dB/m)	Result (dBuV/m)	Limit (dBuV/m)	Margin (dB)	Remark
1	7880.000	38.69	8.01	46.70	74.00	-27.30	peak
2	8870.000	37.90	9.26	47.16	74.00	-26.84	peak
3	11862.000	34.89	15.52	50.41	74.00	-23.59	peak
4	14722.000	32.80	16.67	49.47	74.00	-24.53	peak
5	17087.000	30.62	20.58	51.20	74.00	-22.80	peak
6	17747.000	28.78	22.31	51.09	74.00	-22.91	peak

- Note: 1. Measurement = Reading Level + Correct Factor.
 2. If Peak Result complies with AV limit, AV Result is deemed to comply with AV limit.
 3. Peak: Peak detector.
 4. AVG: $VBW=1/Ton$, where: Ton is the transmitting duration.
 5. For the transmitting duration, please refer to clause 7.1.
 6. Filter losses were only considered in the spurious frequency bands and the authorized band was not corrected for High Pass Filter losses.
 7. Proper operation of the transmitter prior to adding the filter to the measurement chain.
 8. Since non-restricted band peak emissions are less than the average limit, they also comply with the -27dBm/MHz (68.2dBuV/m) limit.

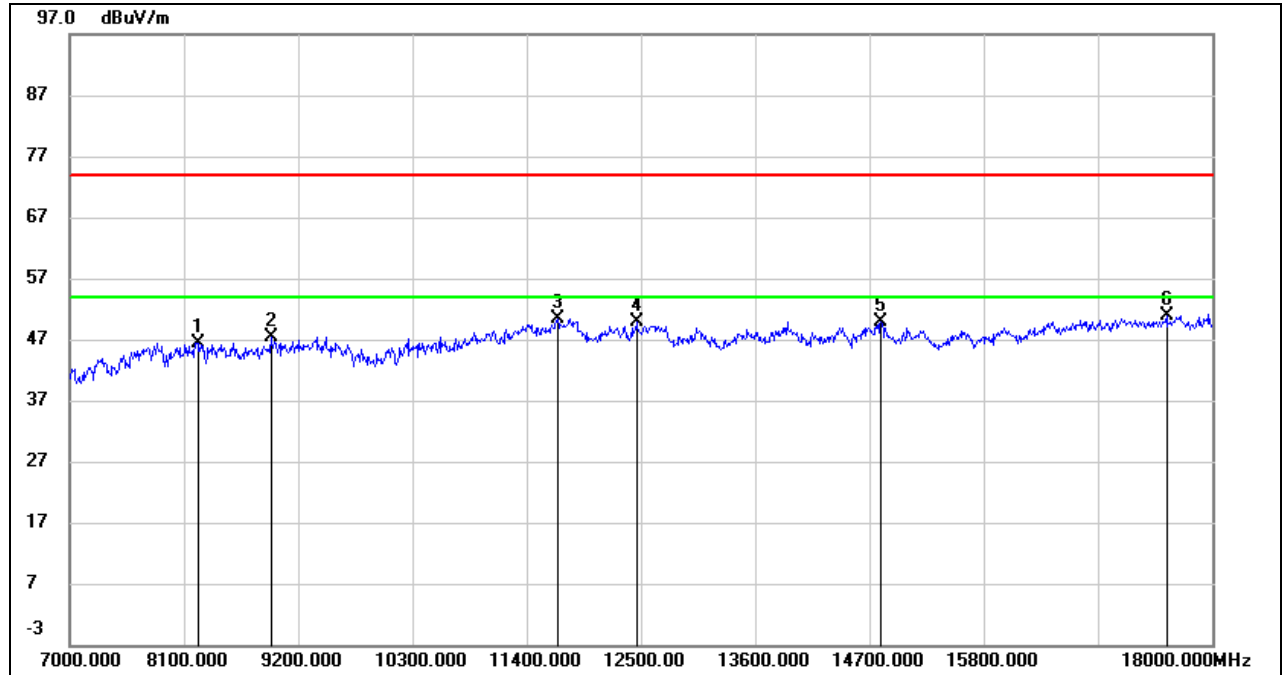
**HARMONICS AND SPURIOUS EMISSIONS (LOW CHANNEL, VERTICAL)**

No.	Frequency (MHz)	Reading (dBuV)	Correct (dB/m)	Result (dBuV/m)	Limit (dBuV/m)	Margin (dB)	Remark
1	8232.000	37.25	9.23	46.48	74.00	-27.52	peak
2	8936.000	37.51	9.96	47.47	74.00	-26.53	peak
3	11697.000	35.38	15.05	50.43	74.00	-23.57	peak
4	12456.000	34.36	15.44	49.80	74.00	-24.20	peak
5	14810.000	33.16	16.80	49.96	74.00	-24.04	peak
6	17560.000	29.77	21.03	50.80	74.00	-23.20	peak

- Note:
1. Measurement = Reading Level + Correct Factor.
 2. If Peak Result complies with AV limit, AV Result is deemed to comply with AV limit.
 3. Peak: Peak detector.
 4. AVG: $VBW=1/Ton$, where: Ton is the transmitting duration.
 5. For the transmitting duration, please refer to clause 7.1.
 6. Filter losses were only considered in the spurious frequency bands and the authorized band was not corrected for High Pass Filter losses.
 7. Proper operation of the transmitter prior to adding the filter to the measurement chain.
 8. Since non-restricted band peak emissions are less than the average limit, they also comply with the -27dBm/MHz (68.2dBuV/m) limit.

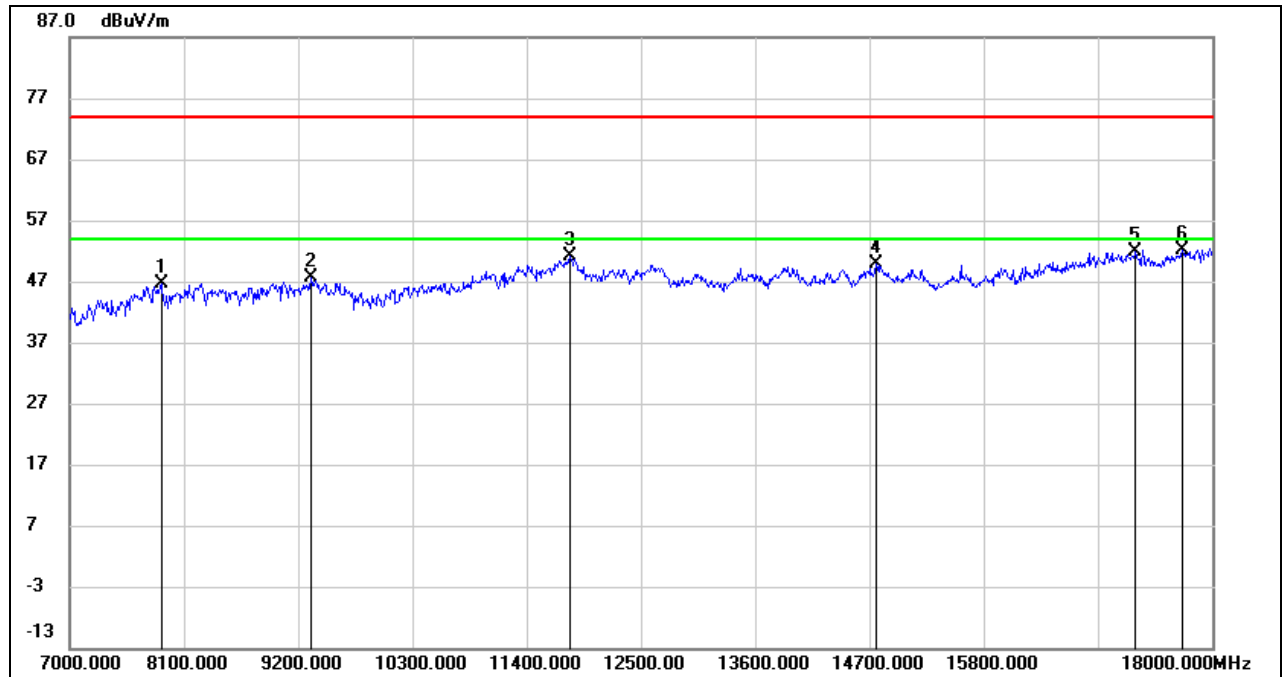
**HARMONICS AND SPURIOUS EMISSIONS (MID CHANNEL, HORIZONTAL)**

No.	Frequency (MHz)	Reading (dBuV)	Correct (dB/m)	Result (dBuV/m)	Limit (dBuV/m)	Margin (dB)	Remark
1	7880.000	38.72	8.01	46.73	74.00	-27.27	peak
2	9321.000	37.79	9.91	47.70	74.00	-26.30	peak
3	11818.000	35.61	15.58	51.19	74.00	-22.81	peak
4	14766.000	33.21	16.74	49.95	74.00	-24.05	peak
5	17263.000	30.91	20.95	51.86	74.00	-22.14	peak
6	17714.000	30.06	22.04	52.10	74.00	-21.90	peak

- Note:
1. Measurement = Reading Level + Correct Factor.
 2. If Peak Result complies with AV limit, AV Result is deemed to comply with AV limit.
 3. Peak: Peak detector.
 4. AVG: $VBW=1/Ton$, where: Ton is the transmitting duration.
 5. For the transmitting duration, please refer to clause 7.1.
 6. Filter losses were only considered in the spurious frequency bands and the authorized band was not corrected for High Pass Filter losses.
 7. Proper operation of the transmitter prior to adding the filter to the measurement chain.
 8. Since non-restricted band peak emissions are less than the average limit, they also comply with the -27dBm/MHz (68.2dBuV/m) limit.

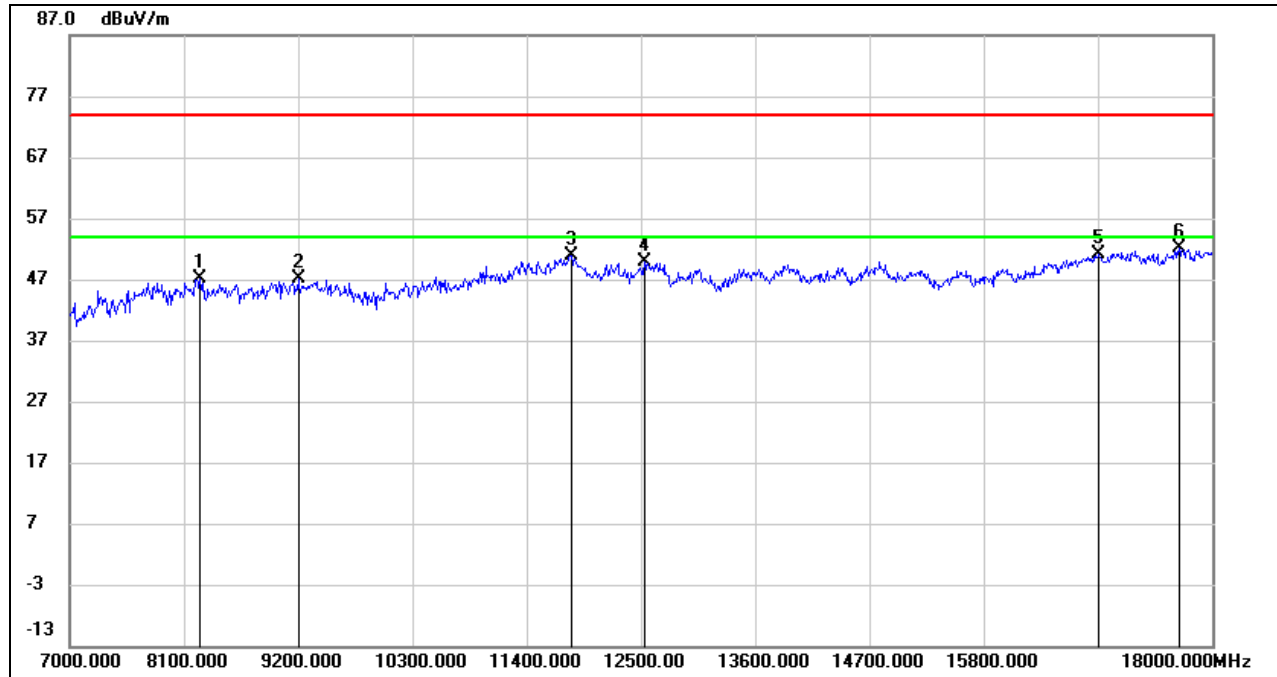
**HARMONICS AND SPURIOUS EMISSIONS (MID CHANNEL, VERTICAL)**

No.	Frequency (MHz)	Reading (dBuV)	Correct (dB/m)	Result (dBuV/m)	Limit (dBuV/m)	Margin (dB)	Remark
1	8254.000	38.04	9.15	47.19	74.00	-26.81	peak
2	9200.000	37.80	9.29	47.09	74.00	-26.91	peak
3	11829.000	35.43	15.57	51.00	74.00	-23.00	peak
4	12533.000	34.57	15.35	49.92	74.00	-24.08	peak
5	16911.000	31.07	20.02	51.09	74.00	-22.91	peak
6	17681.000	30.37	21.79	52.16	74.00	-21.84	peak

Note: 1. Measurement = Reading Level + Correct Factor.

2. If Peak Result complies with AV limit, AV Result is deemed to comply with AV limit.

3. Peak: Peak detector.

4. AVG: $VBW=1/Ton$, where: Ton is the transmitting duration.

5. For the transmitting duration, please refer to clause 7.1.

6. Filter losses were only considered in the spurious frequency bands and the authorized band was not corrected for High Pass Filter losses.

7. Proper operation of the transmitter prior to adding the filter to the measurement chain.

8. Since non-restricted band peak emissions are less than the average limit, they also comply with the -27dBm/MHz (68.2dBuV/m) limit.

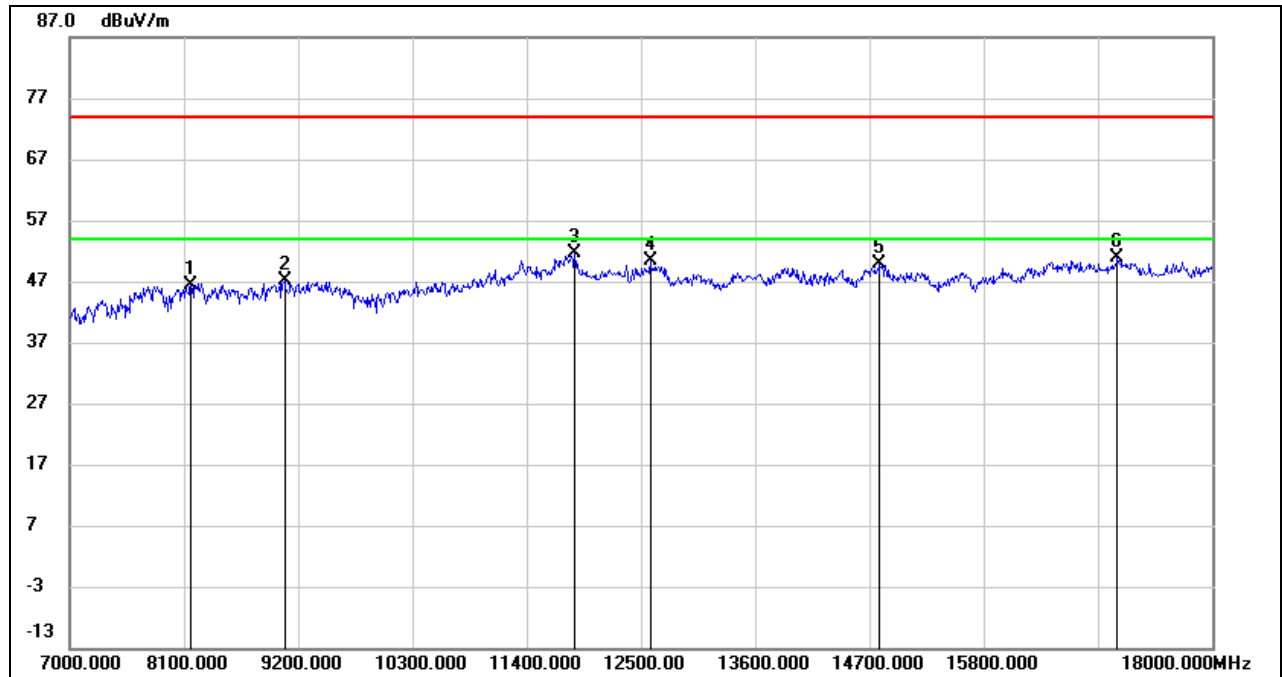
**HARMONICS AND SPURIOUS EMISSIONS (HIGH CHANNEL, HORIZONTAL)**

No.	Frequency (MHz)	Reading (dBuV)	Correct (dB/m)	Result (dBuV/m)	Limit (dBuV/m)	Margin (dB)	Remark
1	8166.000	37.30	9.07	46.37	74.00	-27.63	peak
2	9068.000	37.04	10.17	47.21	74.00	-26.79	peak
3	11862.000	36.04	15.52	51.56	74.00	-22.44	peak
4	12588.000	35.03	15.29	50.32	74.00	-23.68	peak
5	14799.000	33.12	16.80	49.92	74.00	-24.08	peak
6	17087.000	30.32	20.58	50.90	74.00	-23.10	peak

Note: 1. Measurement = Reading Level + Correct Factor.

2. If Peak Result complies with AV limit, AV Result is deemed to comply with AV limit.

3. Peak: Peak detector.

4. AVG: $VBW=1/Ton$, where: Ton is the transmitting duration.

5. For the transmitting duration, please refer to clause 7.1.

6. Filter losses were only considered in the spurious frequency bands and the authorized band was not corrected for High Pass Filter losses.

7. Proper operation of the transmitter prior to adding the filter to the measurement chain.

8. Since non-restricted band peak emissions are less than the average limit, they also comply with the -27dBm/MHz (68.2dBuV/m) limit.

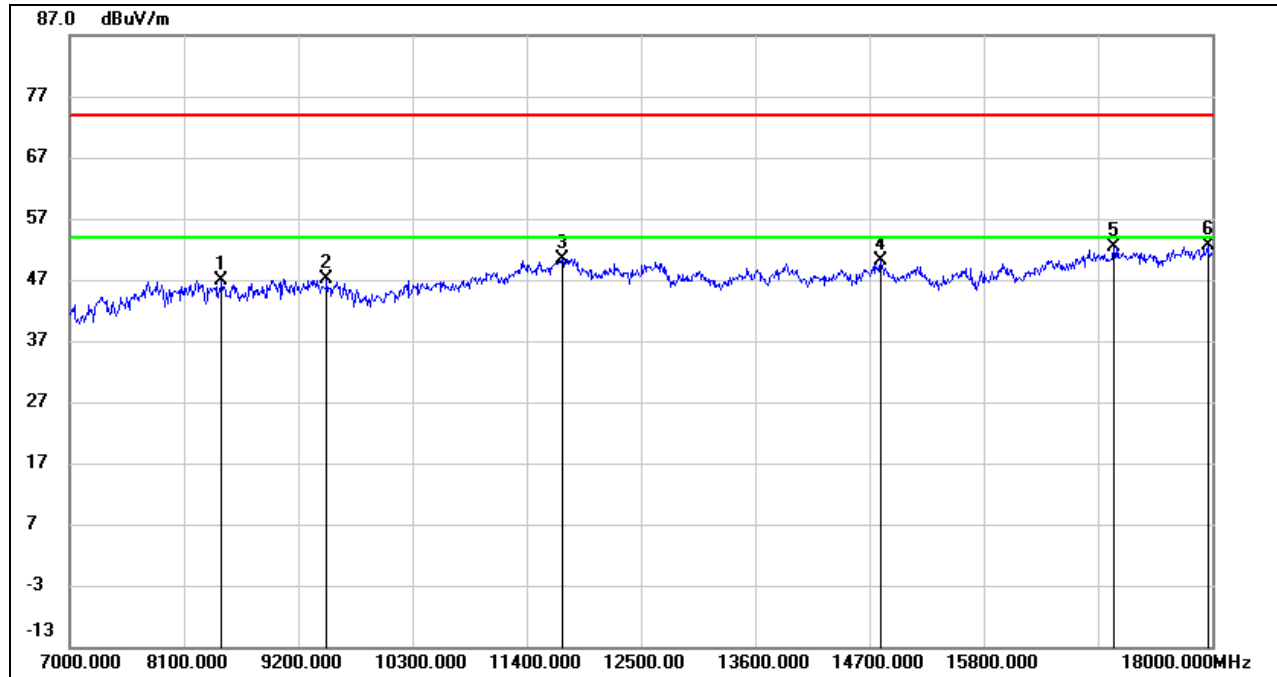
**HARMONICS AND SPURIOUS EMISSIONS (HIGH CHANNEL, VERTICAL)**

No.	Frequency (MHz)	Reading (dBuV)	Correct (dB/m)	Result (dBuV/m)	Limit (dBuV/m)	Margin (dB)	Remark
1	8463.000	38.37	8.55	46.92	74.00	-27.08	peak
2	9475.000	36.67	10.42	47.09	74.00	-26.91	peak
3	11741.000	35.22	15.28	50.50	74.00	-23.50	peak
4	14810.000	33.31	16.80	50.11	74.00	-23.89	peak
5	17054.000	31.91	20.45	52.36	74.00	-21.64	peak
6	17956.000	30.06	22.68	52.74	74.00	-21.26	peak

Note: 1. Measurement = Reading Level + Correct Factor.

2. If Peak Result complies with AV limit, AV Result is deemed to comply with AV limit.

3. Peak: Peak detector.

4. AVG: $VBW=1/Ton$, where: Ton is the transmitting duration.

5. For the transmitting duration, please refer to clause 7.1.

6. Filter losses were only considered in the spurious frequency bands and the authorized band was not corrected for High Pass Filter losses.

7. Proper operation of the transmitter prior to adding the filter to the measurement chain.

8. Since non-restricted band peak emissions are less than the average limit, they also comply with the -27dBm/MHz (68.2dBuV/m) limit.

8.3.4. 5G SRD 3MHz CA MODE

UNII-3 BAND

HARMONICS AND SPURIOUS EMISSIONS (LOW CHANNEL, HORIZONTAL)

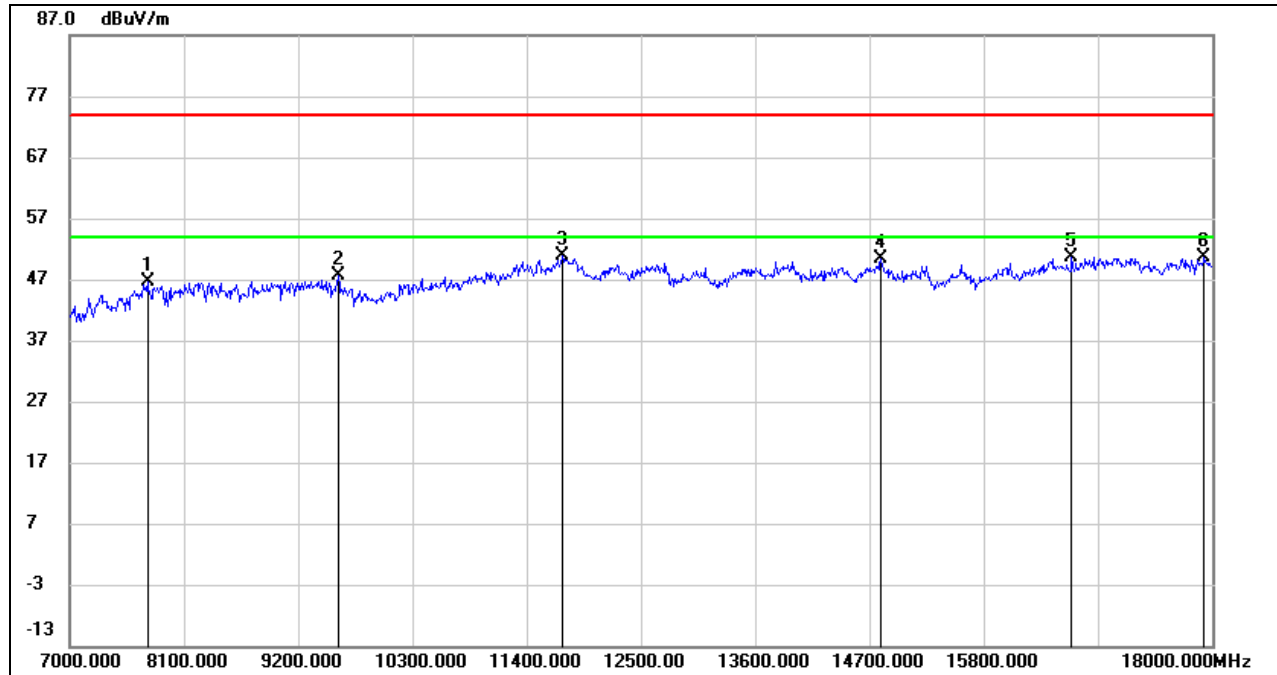

No.	Frequency (MHz)	Reading (dBuV)	Correct (dB/m)	Result (dBuV/m)	Limit (dBuV/m)	Margin (dB)	Remark
1	7748.000	38.70	8.05	46.75	74.00	-27.25	peak
2	9585.000	37.24	10.47	47.71	74.00	-26.29	peak
3	11741.000	35.52	15.28	50.80	74.00	-23.20	peak
4	14810.000	33.54	16.80	50.34	74.00	-23.66	peak
5	16647.000	31.05	19.57	50.62	74.00	-23.38	peak
6	17923.000	27.89	22.69	50.58	74.00	-23.42	peak

- Note: 1. Measurement = Reading Level + Correct Factor.
 2. If Peak Result complies with AV limit, AV Result is deemed to comply with AV limit.
 3. Peak: Peak detector.
 4. AVG: $VBW=1/Ton$, where: Ton is the transmitting duration.
 5. For the transmitting duration, please refer to clause 7.1.
 6. Filter losses were only considered in the spurious frequency bands and the authorized band was not corrected for High Pass Filter losses.
 7. Proper operation of the transmitter prior to adding the filter to the measurement chain.
 8. Since non-restricted band peak emissions are less than the average limit, they also comply with the -27dBm/MHz (68.2dBuV/m) limit.

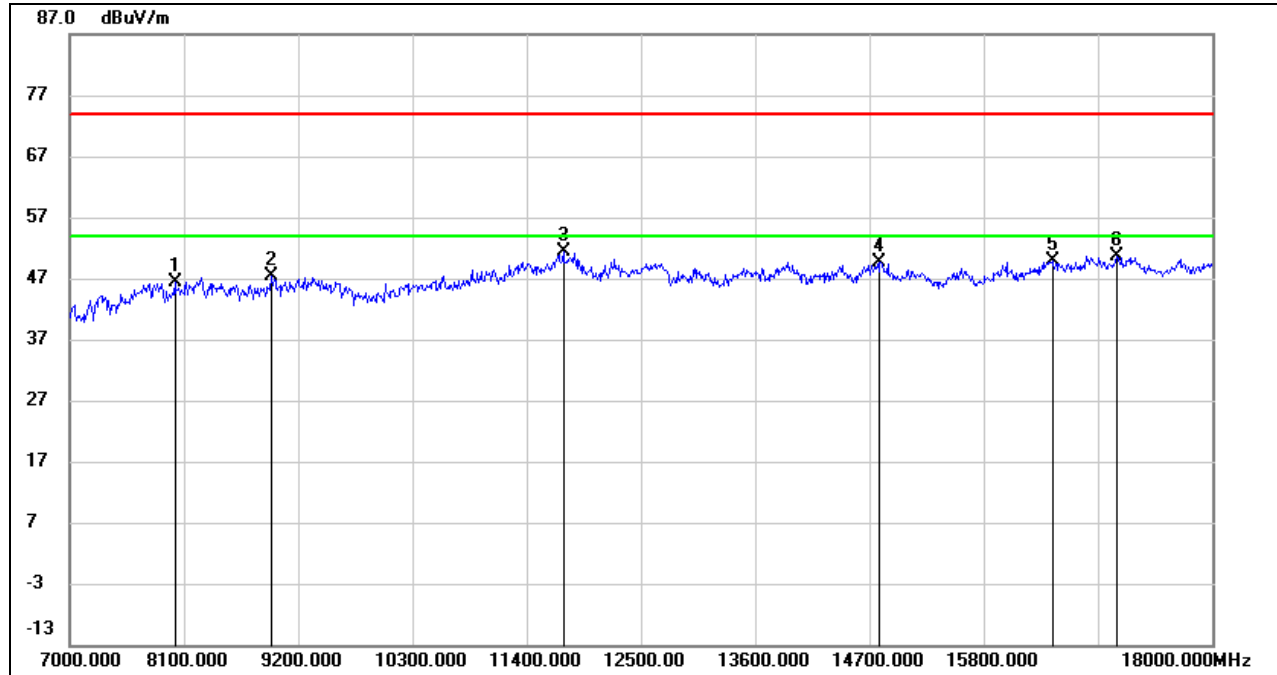
**HARMONICS AND SPURIOUS EMISSIONS (LOW CHANNEL, VERTICAL)**

No.	Frequency (MHz)	Reading (dBuV)	Correct (dB/m)	Result (dBuV/m)	Limit (dBuV/m)	Margin (dB)	Remark
1	8012.000	38.69	7.76	46.45	74.00	-27.55	peak
2	8936.000	37.30	9.96	47.26	74.00	-26.74	peak
3	11752.000	35.97	15.35	51.32	74.00	-22.68	peak
4	14799.000	32.83	16.80	49.63	74.00	-24.37	peak
5	16460.000	31.02	18.96	49.98	74.00	-24.02	peak
6	17076.000	30.18	20.54	50.72	74.00	-23.28	peak

- Note: 1. Measurement = Reading Level + Correct Factor.
 2. If Peak Result complies with AV limit, AV Result is deemed to comply with AV limit.
 3. Peak: Peak detector.
 4. AVG: $VBW=1/Ton$, where: Ton is the transmitting duration.
 5. For the transmitting duration, please refer to clause 7.1.
 6. Filter losses were only considered in the spurious frequency bands and the authorized band was not corrected for High Pass Filter losses.
 7. Proper operation of the transmitter prior to adding the filter to the measurement chain.
 8. Since non-restricted band peak emissions are less than the average limit, they also comply with the -27dBm/MHz (68.2dBuV/m) limit.

HARMONICS AND SPURIOUS EMISSIONS (MID CHANNEL, HORIZONTAL)

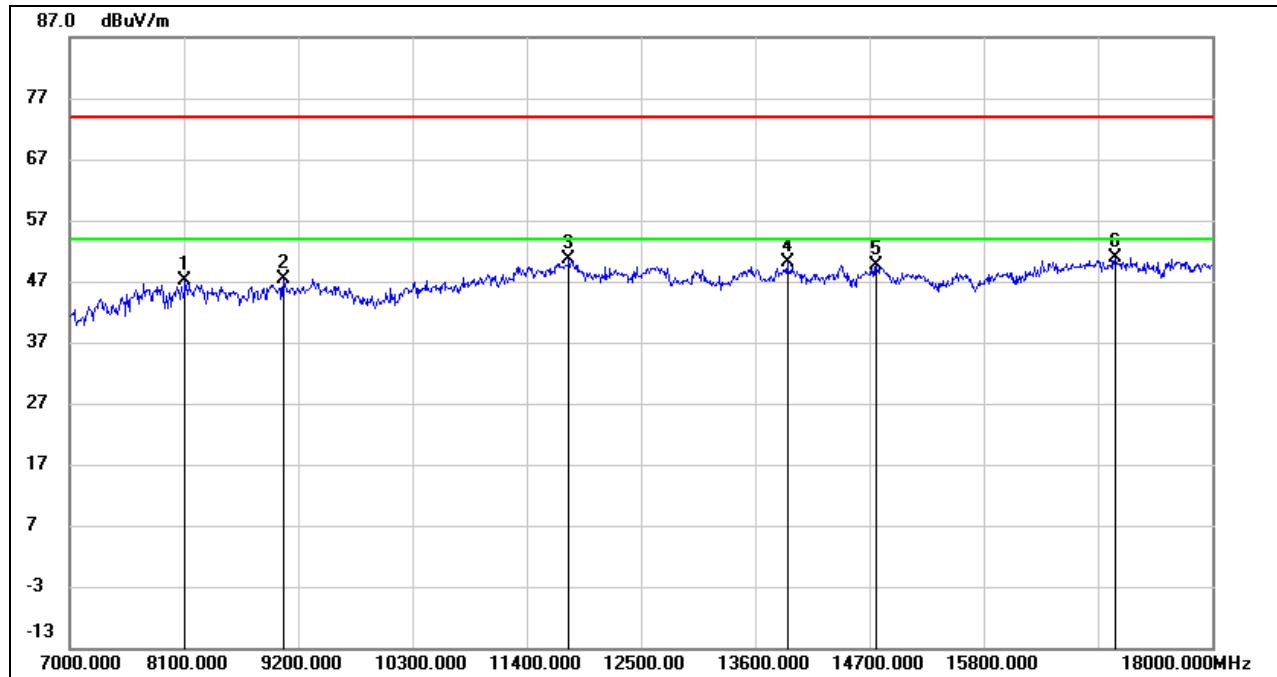

No.	Frequency (MHz)	Reading (dBuV)	Correct (dB/m)	Result (dBuV/m)	Limit (dBuV/m)	Margin (dB)	Remark
1	8111.000	38.60	8.61	47.21	74.00	-26.79	peak
2	9057.000	37.08	10.26	47.34	74.00	-26.66	peak
3	11807.000	35.00	15.61	50.61	74.00	-23.39	peak
4	13908.000	33.11	16.90	50.01	74.00	-23.99	peak
5	14766.000	32.84	16.74	49.58	74.00	-24.42	peak
6	17065.000	30.32	20.49	50.81	74.00	-23.19	peak

- Note:
1. Measurement = Reading Level + Correct Factor.
 2. If Peak Result complies with AV limit, AV Result is deemed to comply with AV limit.
 3. Peak: Peak detector.
 4. AVG: $VBW=1/Ton$, where: Ton is the transmitting duration.
 5. For the transmitting duration, please refer to clause 7.1.
 6. Filter losses were only considered in the spurious frequency bands and the authorized band was not corrected for High Pass Filter losses.
 7. Proper operation of the transmitter prior to adding the filter to the measurement chain.
 8. Since non-restricted band peak emissions are less than the average limit, they also comply with the -27dBm/MHz (68.2dBuV/m) limit.

HARMONICS AND SPURIOUS EMISSIONS (MID CHANNEL, VERTICAL)

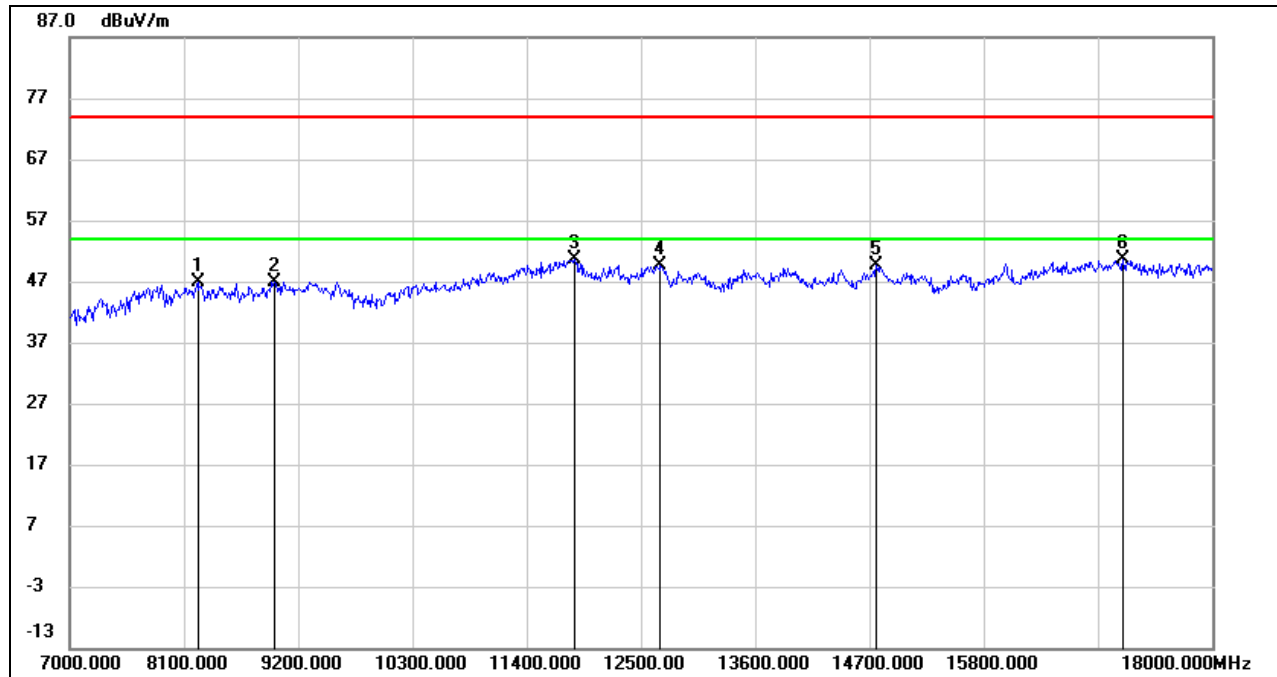

No.	Frequency (MHz)	Reading (dBuV)	Correct (dB/m)	Result (dBuV/m)	Limit (dBuV/m)	Margin (dB)	Remark
1	8232.000	37.61	9.23	46.84	74.00	-27.16	peak
2	8969.000	36.65	10.31	46.96	74.00	-27.04	peak
3	11862.000	35.01	15.52	50.53	74.00	-23.47	peak
4	12687.000	34.22	15.45	49.67	74.00	-24.33	peak
5	14766.000	32.86	16.74	49.60	74.00	-24.40	peak
6	17142.000	29.86	20.80	50.66	74.00	-23.34	peak

Note: 1. Measurement = Reading Level + Correct Factor.

2. If Peak Result complies with AV limit, AV Result is deemed to comply with AV limit.

3. Peak: Peak detector.

4. AVG: $VBW=1/Ton$, where: Ton is the transmitting duration.

5. For the transmitting duration, please refer to clause 7.1.

6. Filter losses were only considered in the spurious frequency bands and the authorized band was not corrected for High Pass Filter losses.

7. Proper operation of the transmitter prior to adding the filter to the measurement chain.

8. Since non-restricted band peak emissions are less than the average limit, they also comply with the -27dBm/MHz (68.2dBuV/m) limit.

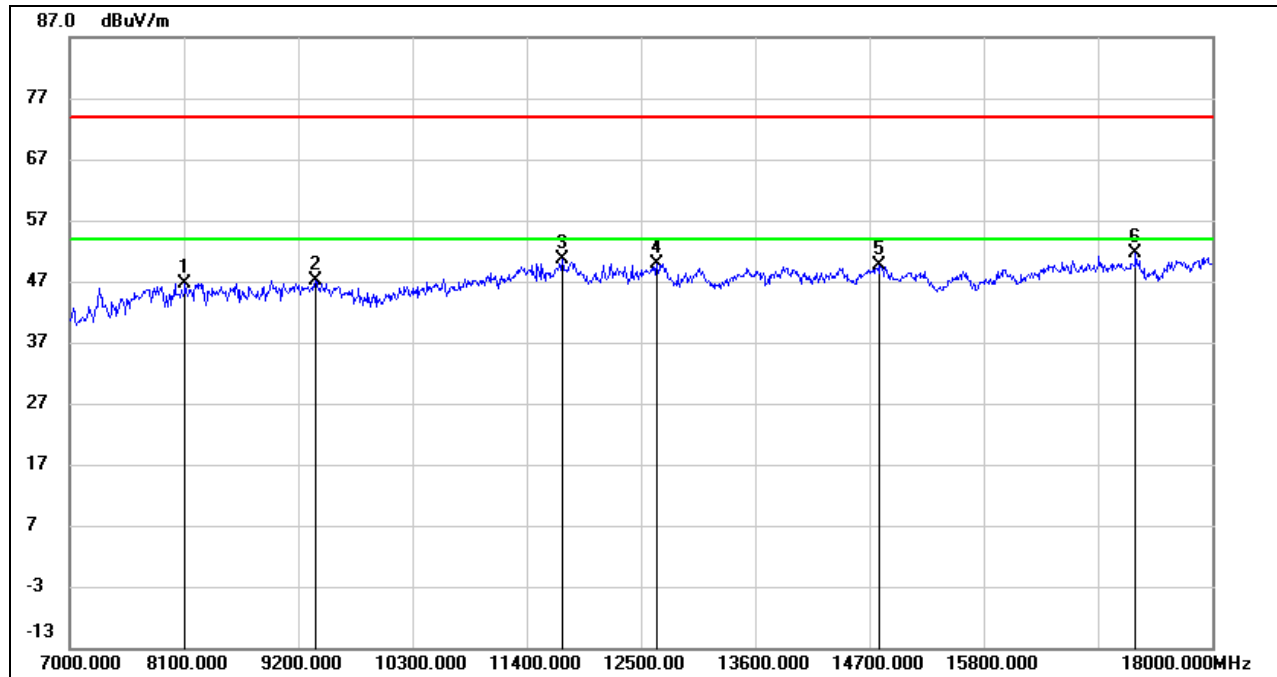
**HARMONICS AND SPURIOUS EMISSIONS (HIGH CHANNEL, HORIZONTAL)**

No.	Frequency (MHz)	Reading (dBuV)	Correct (dB/m)	Result (dBuV/m)	Limit (dBuV/m)	Margin (dB)	Remark
1	8111.000	38.07	8.61	46.68	74.00	-27.32	peak
2	9365.000	37.02	10.13	47.15	74.00	-26.85	peak
3	11741.000	35.41	15.28	50.69	74.00	-23.31	peak
4	12654.000	34.43	15.38	49.81	74.00	-24.19	peak
5	14799.000	32.72	16.80	49.52	74.00	-24.48	peak
6	17263.000	30.65	20.95	51.60	74.00	-22.40	peak

Note: 1. Measurement = Reading Level + Correct Factor.

2. If Peak Result complies with AV limit, AV Result is deemed to comply with AV limit.

3. Peak: Peak detector.

4. AVG: $VBW=1/Ton$, where: Ton is the transmitting duration.

5. For the transmitting duration, please refer to clause 7.1.

6. Filter losses were only considered in the spurious frequency bands and the authorized band was not corrected for High Pass Filter losses.

7. Proper operation of the transmitter prior to adding the filter to the measurement chain.

8. Since non-restricted band peak emissions are less than the average limit, they also comply with the -27dBm/MHz (68.2dBuV/m) limit.

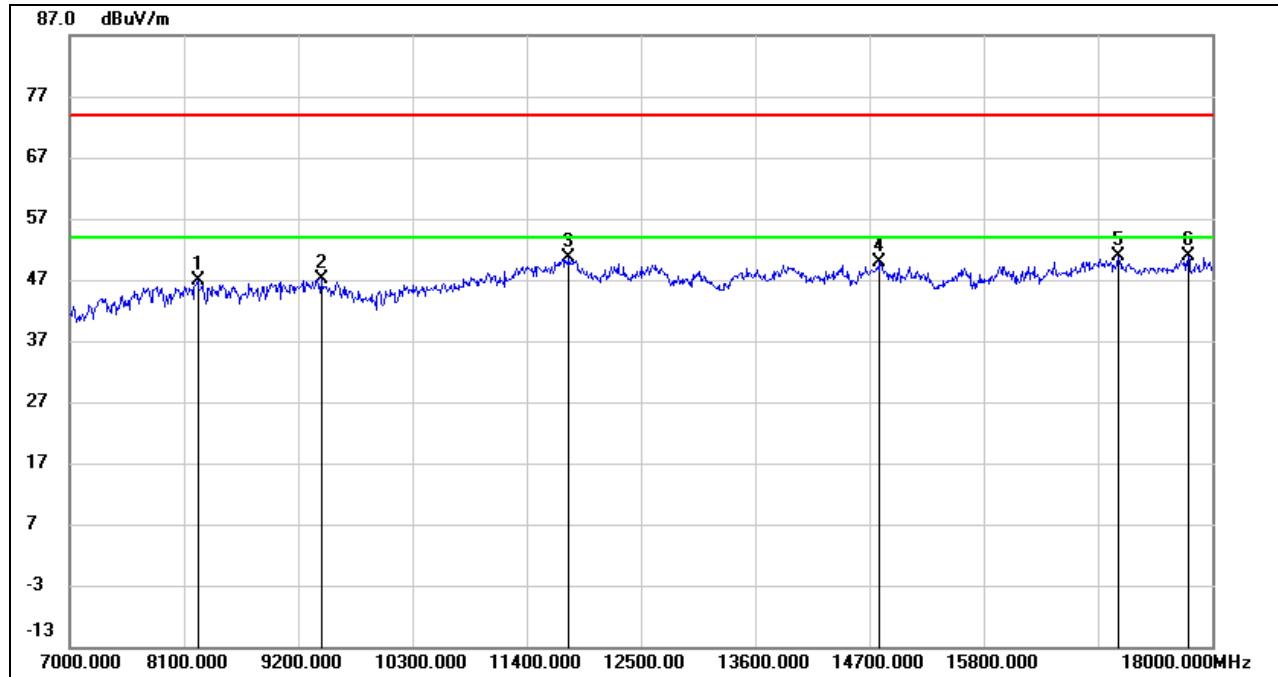
**HARMONICS AND SPURIOUS EMISSIONS (HIGH CHANNEL, VERTICAL)**

No.	Frequency (MHz)	Reading (dBuV)	Correct (dB/m)	Result (dBuV/m)	Limit (dBuV/m)	Margin (dB)	Remark
1	8232.000	37.61	9.23	46.84	74.00	-27.16	peak
2	9420.000	36.89	10.34	47.23	74.00	-26.77	peak
3	11807.000	34.96	15.61	50.57	74.00	-23.43	peak
4	14799.000	33.16	16.80	49.96	74.00	-24.04	peak
5	17098.000	30.27	20.63	50.90	74.00	-23.10	peak
6	17769.000	28.38	22.48	50.86	74.00	-23.14	peak

Note: 1. Measurement = Reading Level + Correct Factor.

2. If Peak Result complies with AV limit, AV Result is deemed to comply with AV limit.

3. Peak: Peak detector.

4. AVG: $VBW=1/Ton$, where: Ton is the transmitting duration.

5. For the transmitting duration, please refer to clause 7.1.

6. Filter losses were only considered in the spurious frequency bands and the authorized band was not corrected for High Pass Filter losses.

7. Proper operation of the transmitter prior to adding the filter to the measurement chain.

8. Since non-restricted band peak emissions are less than the average limit, they also comply with the -27dBm/MHz (68.2dBuV/m) limit.



8.3.5. 5G SRD 10MHz MODE

UNII-3 BAND

HARMONICS AND SPURIOUS EMISSIONS (LOW CHANNEL, HORIZONTAL)

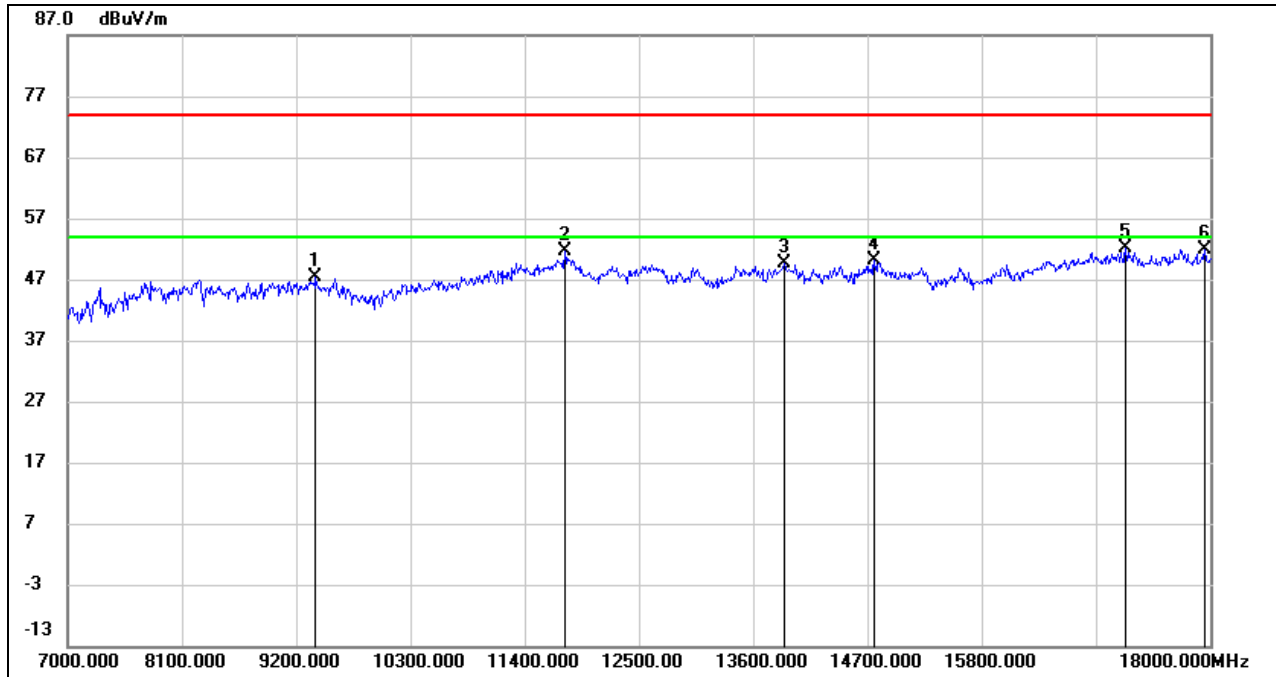

No.	Frequency (MHz)	Reading (dBuV)	Correct (dB/m)	Result (dBuV/m)	Limit (dBuV/m)	Margin (dB)	Remark
1	9387.000	37.04	10.24	47.28	74.00	-26.72	peak
2	11785.000	36.13	15.52	51.65	74.00	-22.35	peak
3	13897.000	32.73	16.90	49.63	74.00	-24.37	peak
4	14766.000	33.27	16.74	50.01	74.00	-23.99	peak
5	17186.000	31.22	20.98	52.20	74.00	-21.80	peak
6	17945.000	29.29	22.68	51.97	74.00	-22.03	peak

- Note: 1. Measurement = Reading Level + Correct Factor.
 2. If Peak Result complies with AV limit, AV Result is deemed to comply with AV limit.
 3. Peak: Peak detector.
 4. AVG: $VBW=1/T_{on}$, where: T_{on} is the transmitting duration.
 5. For the transmitting duration, please refer to clause 7.1.
 6. Filter losses were only considered in the spurious frequency bands and the authorized band was not corrected for High Pass Filter losses.
 7. Proper operation of the transmitter prior to adding the filter to the measurement chain.
 8. Since non-restricted band peak emissions are less than the average limit, they also comply with the -27dBm/MHz (68.2dBuV/m) limit.

HARMONICS AND SPURIOUS EMISSIONS (LOW CHANNEL, VERTICAL)

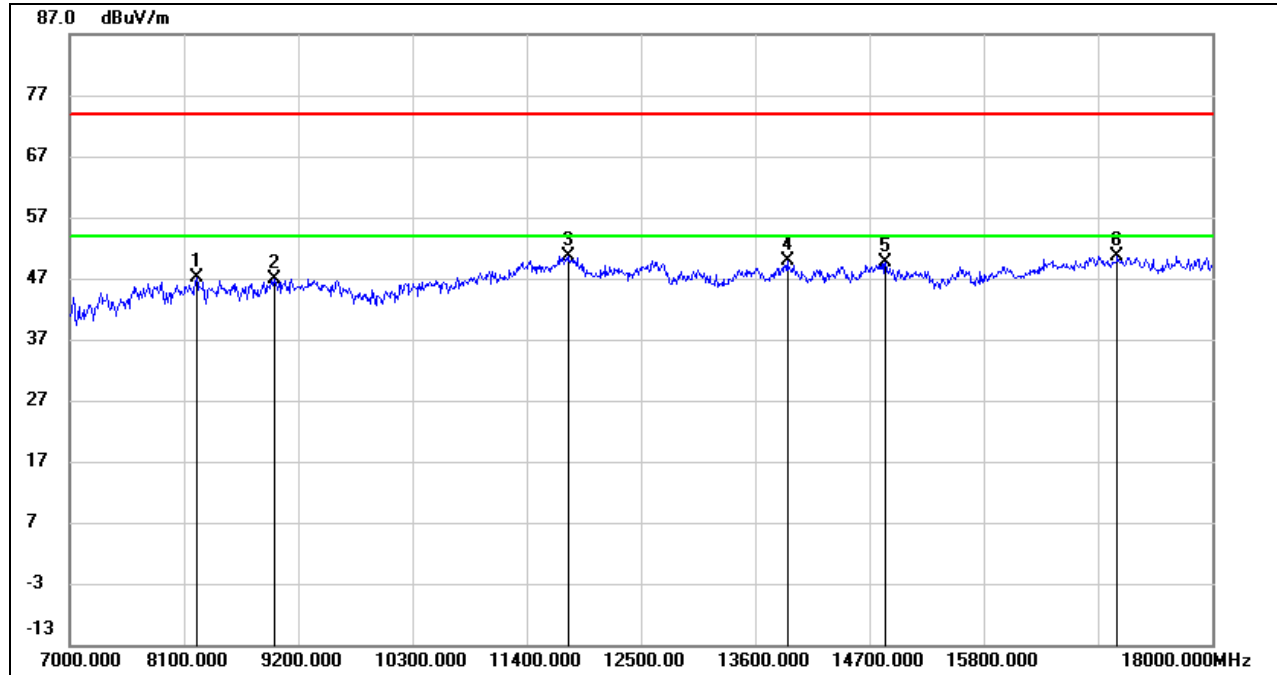

No.	Frequency (MHz)	Reading (dBuV)	Correct (dB/m)	Result (dBuV/m)	Limit (dBuV/m)	Margin (dB)	Remark
1	8221.000	37.77	9.28	47.05	74.00	-26.95	peak
2	8969.000	36.48	10.31	46.79	74.00	-27.21	peak
3	11807.000	35.09	15.61	50.70	74.00	-23.30	peak
4	13908.000	33.09	16.90	49.99	74.00	-24.01	peak
5	14854.000	32.68	16.83	49.51	74.00	-24.49	peak
6	17087.000	30.09	20.58	50.67	74.00	-23.33	peak

- Note:
1. Measurement = Reading Level + Correct Factor.
 2. If Peak Result complies with AV limit, AV Result is deemed to comply with AV limit.
 3. Peak: Peak detector.
 4. AVG: $VBW=1/Ton$, where: Ton is the transmitting duration.
 5. For the transmitting duration, please refer to clause 7.1.
 6. Filter losses were only considered in the spurious frequency bands and the authorized band was not corrected for High Pass Filter losses.
 7. Proper operation of the transmitter prior to adding the filter to the measurement chain.
 8. Since non-restricted band peak emissions are less than the average limit, they also comply with the -27dBm/MHz (68.2dBuV/m) limit.

HARMONICS AND SPURIOUS EMISSIONS (MID CHANNEL, HORIZONTAL)

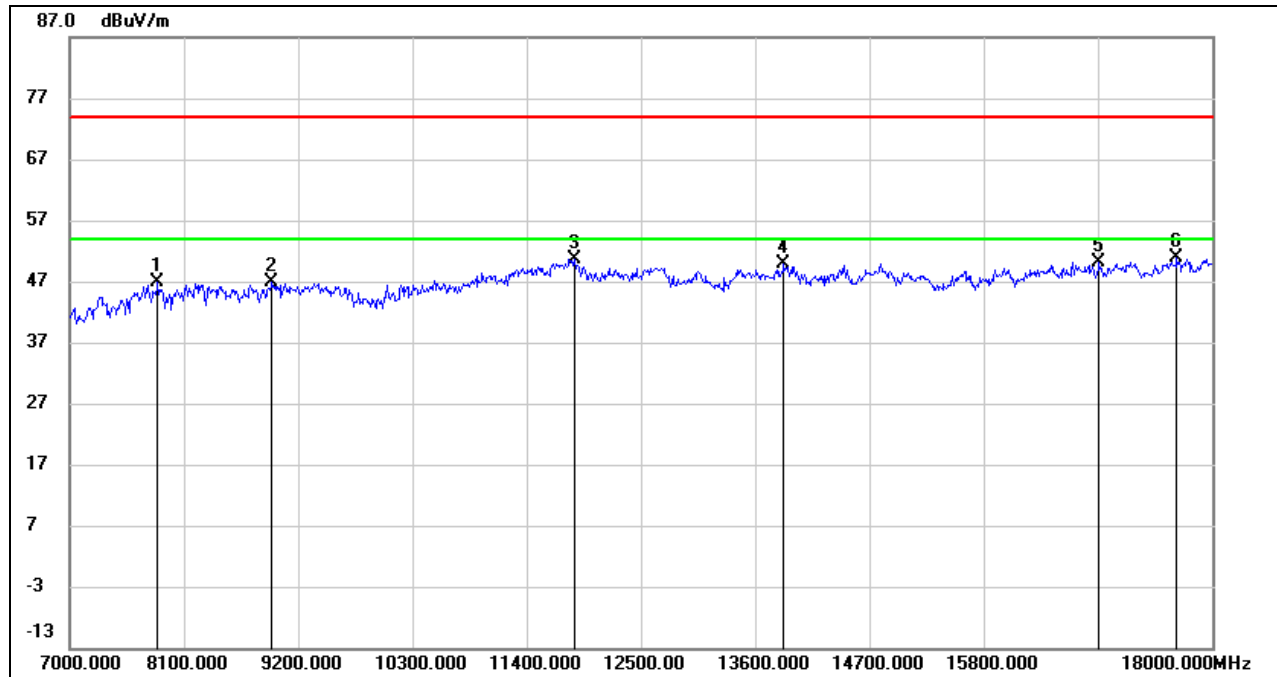

No.	Frequency (MHz)	Reading (dBuV)	Correct (dB/m)	Result (dBuV/m)	Limit (dBuV/m)	Margin (dB)	Remark
1	7847.000	38.71	8.11	46.82	74.00	-27.18	peak
2	8947.000	36.90	10.07	46.97	74.00	-27.03	peak
3	11862.000	35.03	15.52	50.55	74.00	-23.45	peak
4	13875.000	32.86	16.92	49.78	74.00	-24.22	peak
5	16911.000	30.19	20.02	50.21	74.00	-23.79	peak
6	17659.000	29.27	21.63	50.90	74.00	-23.10	peak

- Note:
1. Measurement = Reading Level + Correct Factor.
 2. If Peak Result complies with AV limit, AV Result is deemed to comply with AV limit.
 3. Peak: Peak detector.
 4. AVG: $VBW=1/Ton$, where: Ton is the transmitting duration.
 5. For the transmitting duration, please refer to clause 7.1.
 6. Filter losses were only considered in the spurious frequency bands and the authorized band was not corrected for High Pass Filter losses.
 7. Proper operation of the transmitter prior to adding the filter to the measurement chain.
 8. Since non-restricted band peak emissions are less than the average limit, they also comply with the -27dBm/MHz (68.2dBuV/m) limit.

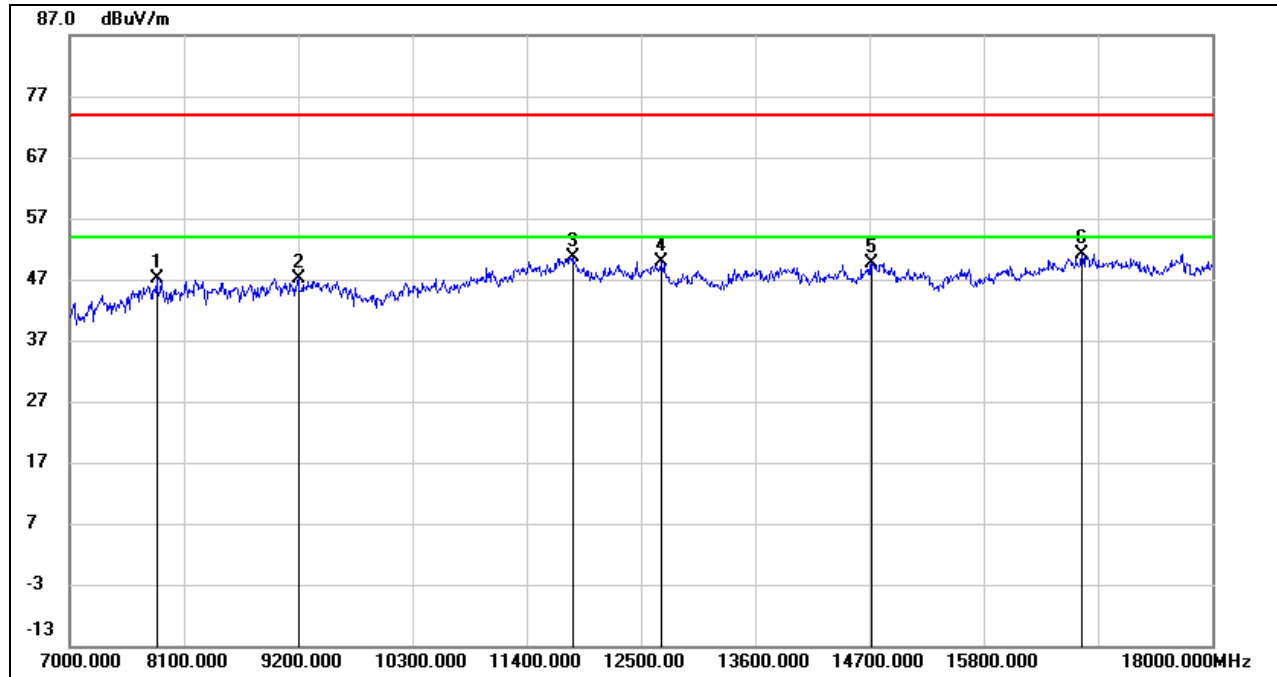
**HARMONICS AND SPURIOUS EMISSIONS (MID CHANNEL, VERTICAL)**

No.	Frequency (MHz)	Reading (dBuV)	Correct (dB/m)	Result (dBuV/m)	Limit (dBuV/m)	Margin (dB)	Remark
1	7836.000	38.92	8.14	47.06	74.00	-26.94	peak
2	9200.000	37.73	9.29	47.02	74.00	-26.98	peak
3	11840.000	35.09	15.56	50.65	74.00	-23.35	peak
4	12698.000	34.48	15.47	49.95	74.00	-24.05	peak
5	14722.000	33.01	16.67	49.68	74.00	-24.32	peak
6	16746.000	31.47	19.68	51.15	74.00	-22.85	peak

Note: 1. Measurement = Reading Level + Correct Factor.

2. If Peak Result complies with AV limit, AV Result is deemed to comply with AV limit.

3. Peak: Peak detector.

4. AVG: $VBW=1/Ton$, where: Ton is the transmitting duration.

5. For the transmitting duration, please refer to clause 7.1.

6. Filter losses were only considered in the spurious frequency bands and the authorized band was not corrected for High Pass Filter losses.

7. Proper operation of the transmitter prior to adding the filter to the measurement chain.

8. Since non-restricted band peak emissions are less than the average limit, they also comply with the -27dBm/MHz (68.2dBuV/m) limit.

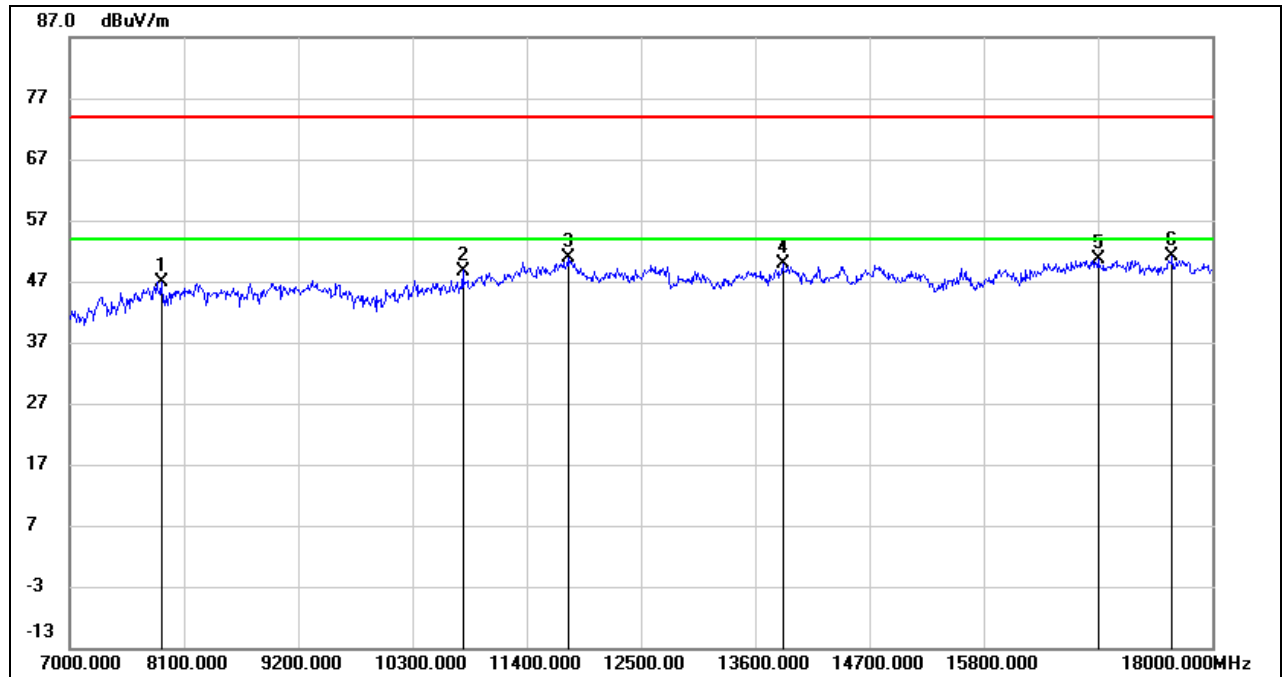
**HARMONICS AND SPURIOUS EMISSIONS (HIGH CHANNEL, HORIZONTAL)**

No.	Frequency (MHz)	Reading (dBuV)	Correct (dB/m)	Result (dBuV/m)	Limit (dBuV/m)	Margin (dB)	Remark
1	7880.000	38.97	8.01	46.98	74.00	-27.02	peak
2	10784.000	36.10	12.65	48.75	74.00	-25.25	peak
3	11796.000	35.25	15.59	50.84	74.00	-23.16	peak
4	13864.000	33.02	16.92	49.94	74.00	-24.06	peak
5	16900.000	30.57	19.98	50.55	74.00	-23.45	peak
6	17615.000	29.88	21.29	51.17	74.00	-22.83	peak

- Note:
1. Measurement = Reading Level + Correct Factor.
 2. If Peak Result complies with AV limit, AV Result is deemed to comply with AV limit.
 3. Peak: Peak detector.
 4. AVG: $VBW=1/Ton$, where: Ton is the transmitting duration.
 5. For the transmitting duration, please refer to clause 7.1.
 6. Filter losses were only considered in the spurious frequency bands and the authorized band was not corrected for High Pass Filter losses.
 7. Proper operation of the transmitter prior to adding the filter to the measurement chain.
 8. Since non-restricted band peak emissions are less than the average limit, they also comply with the -27dBm/MHz (68.2dBuV/m) limit.

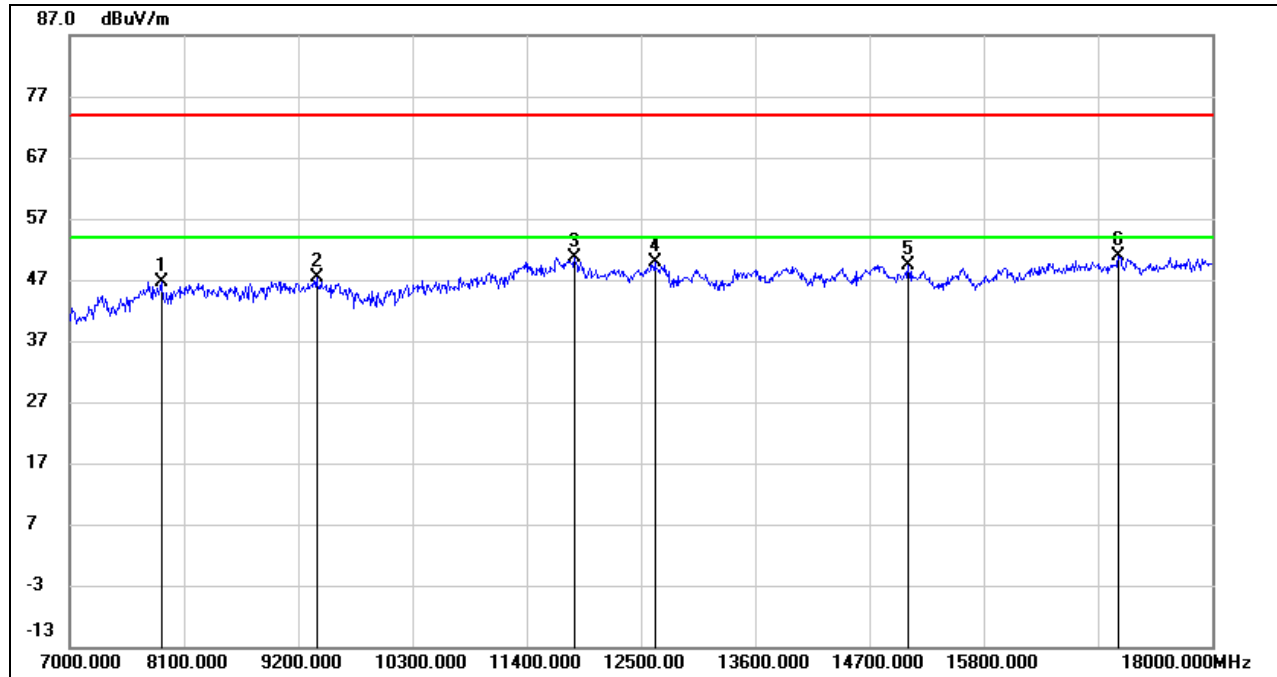
**HARMONICS AND SPURIOUS EMISSIONS (HIGH CHANNEL, VERTICAL)**

No.	Frequency (MHz)	Reading (dBuV)	Correct (dB/m)	Result (dBuV/m)	Limit (dBuV/m)	Margin (dB)	Remark
1	7880.000	38.59	8.01	46.60	74.00	-27.40	peak
2	9376.000	37.23	10.19	47.42	74.00	-26.58	peak
3	11862.000	35.16	15.52	50.68	74.00	-23.32	peak
4	12632.000	34.45	15.35	49.80	74.00	-24.20	peak
5	15074.000	32.81	16.64	49.45	74.00	-24.55	peak
6	17098.000	30.22	20.63	50.85	74.00	-23.15	peak

Note: 1. Measurement = Reading Level + Correct Factor.

2. If Peak Result complies with AV limit, AV Result is deemed to comply with AV limit.

3. Peak: Peak detector.

4. AVG: $VBW=1/Ton$, where: Ton is the transmitting duration.

5. For the transmitting duration, please refer to clause 7.1.

6. Filter losses were only considered in the spurious frequency bands and the authorized band was not corrected for High Pass Filter losses.

7. Proper operation of the transmitter prior to adding the filter to the measurement chain.

8. Since non-restricted band peak emissions are less than the average limit, they also comply with the -27dBm/MHz (68.2dBuV/m) limit.

8.3.6. 5G SRD 20MHz MODE

UNII-3 BAND

HARMONICS AND SPURIOUS EMISSIONS (LOW CHANNEL, HORIZONTAL)

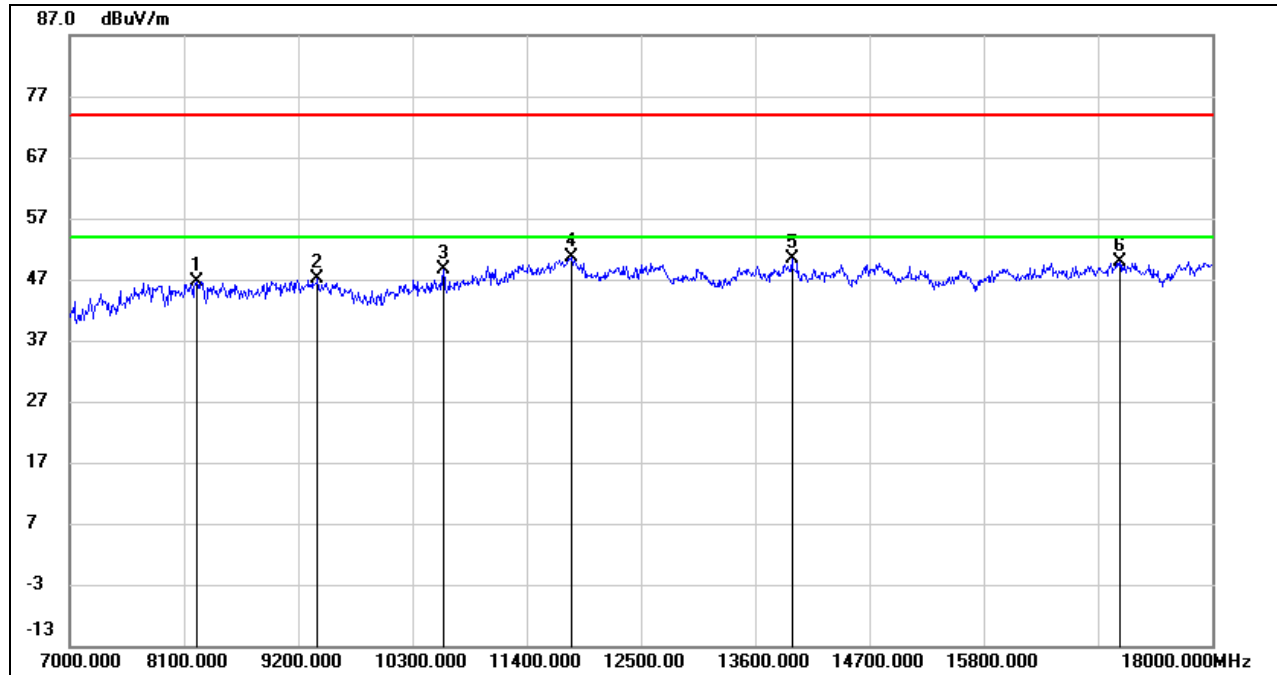

No.	Frequency (MHz)	Reading (dBuV)	Correct (dB/m)	Result (dBuV/m)	Limit (dBuV/m)	Margin (dB)	Remark
1	8221.000	37.46	9.28	46.74	74.00	-27.26	peak
2	9387.000	36.78	10.24	47.02	74.00	-26.98	peak
3	10597.000	36.16	12.35	48.51	74.00	-25.49	peak
4	11829.000	35.06	15.57	50.63	74.00	-23.37	peak
5	13952.000	33.45	16.88	50.33	74.00	-23.67	peak
6	17109.000	29.30	20.67	49.97	74.00	-24.03	peak

- Note:
1. Measurement = Reading Level + Correct Factor.
 2. If Peak Result complies with AV limit, AV Result is deemed to comply with AV limit.
 3. Peak: Peak detector.
 4. AVG: $VBW=1/Ton$, where: Ton is the transmitting duration.
 5. For the transmitting duration, please refer to clause 7.1.
 6. Filter losses were only considered in the spurious frequency bands and the authorized band was not corrected for High Pass Filter losses.
 7. Proper operation of the transmitter prior to adding the filter to the measurement chain.
 8. Since non-restricted band peak emissions are less than the average limit, they also comply with the -27dBm/MHz (68.2dBuV/m) limit.

HARMONICS AND SPURIOUS EMISSIONS (LOW CHANNEL, VERTICAL)

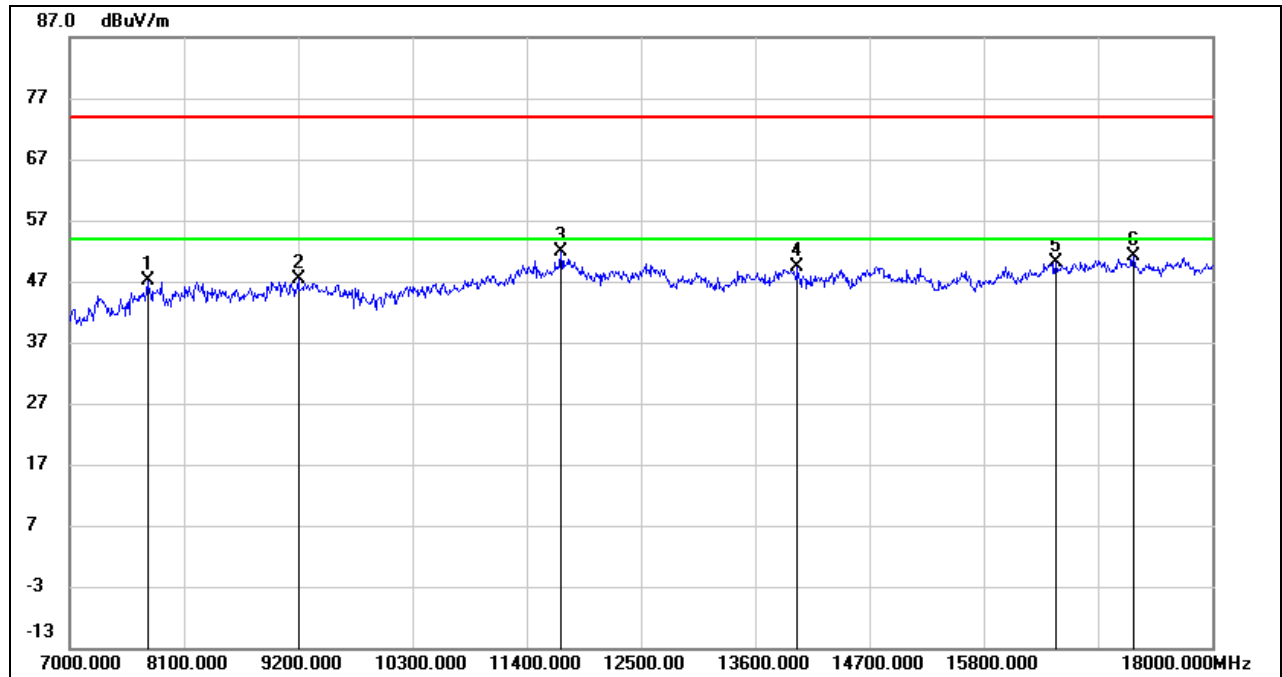

No.	Frequency (MHz)	Reading (dBuV)	Correct (dB/m)	Result (dBuV/m)	Limit (dBuV/m)	Margin (dB)	Remark
1	7748.000	39.16	8.05	47.21	74.00	-26.79	peak
2	9200.000	38.02	9.29	47.31	74.00	-26.69	peak
3	11730.000	36.61	15.23	51.84	74.00	-22.16	peak
4	14007.000	32.51	16.85	49.36	74.00	-24.64	peak
5	16493.000	31.16	19.09	50.25	74.00	-23.75	peak
6	17241.000	30.15	20.97	51.12	74.00	-22.88	peak

Note: 1. Measurement = Reading Level + Correct Factor.

2. If Peak Result complies with AV limit, AV Result is deemed to comply with AV limit.

3. Peak: Peak detector.

4. AVG: $VBW=1/Ton$, where: Ton is the transmitting duration.

5. For the transmitting duration, please refer to clause 7.1.

6. Filter losses were only considered in the spurious frequency bands and the authorized band was not corrected for High Pass Filter losses.

7. Proper operation of the transmitter prior to adding the filter to the measurement chain.

8. Since non-restricted band peak emissions are less than the average limit, they also comply with the -27dBm/MHz (68.2dBuV/m) limit.

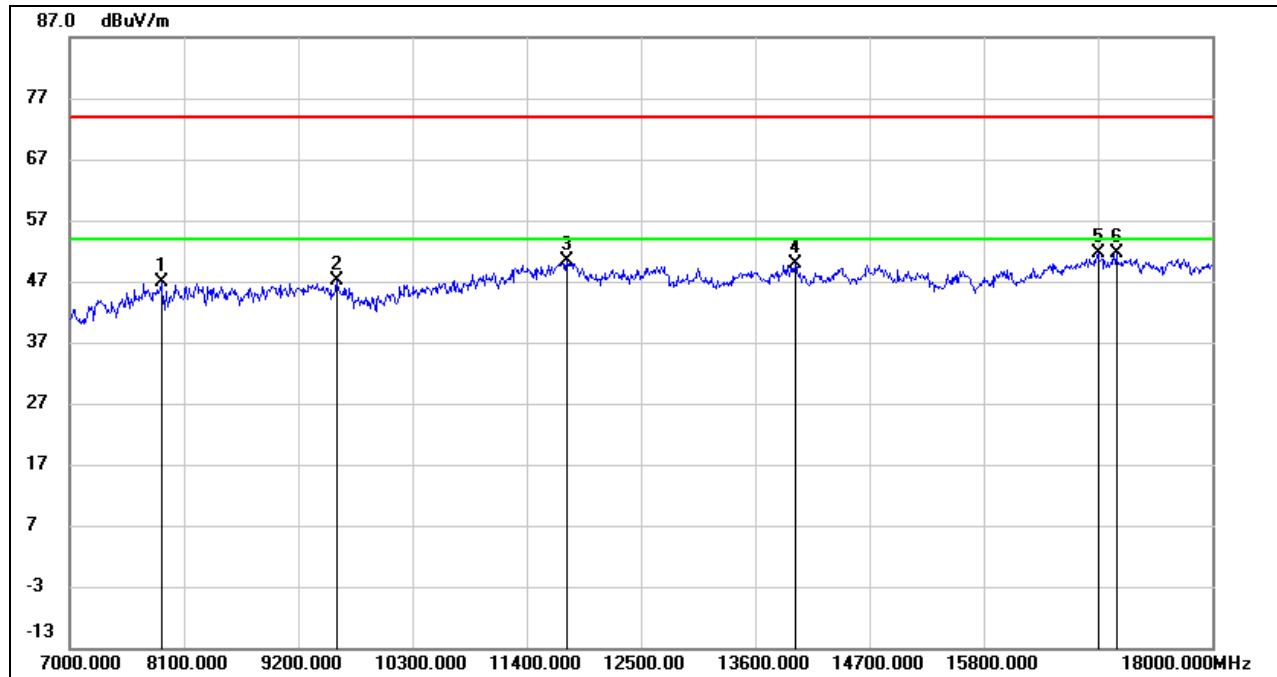
**HARMONICS AND SPURIOUS EMISSIONS (MID CHANNEL, HORIZONTAL)**

No.	Frequency (MHz)	Reading (dBuV)	Correct (dB/m)	Result (dBuV/m)	Limit (dBuV/m)	Margin (dB)	Remark
1	7880.000	38.91	8.01	46.92	74.00	-27.08	peak
2	9574.000	36.55	10.46	47.01	74.00	-26.99	peak
3	11785.000	34.77	15.52	50.29	74.00	-23.71	peak
4	13985.000	32.93	16.86	49.79	74.00	-24.21	peak
5	16900.000	31.56	19.98	51.54	74.00	-22.46	peak
6	17076.000	31.20	20.54	51.74	74.00	-22.26	peak

- Note:
1. Measurement = Reading Level + Correct Factor.
 2. If Peak Result complies with AV limit, AV Result is deemed to comply with AV limit.
 3. Peak: Peak detector.
 4. AVG: $VBW=1/Ton$, where: Ton is the transmitting duration.
 5. For the transmitting duration, please refer to clause 7.1.
 6. Filter losses were only considered in the spurious frequency bands and the authorized band was not corrected for High Pass Filter losses.
 7. Proper operation of the transmitter prior to adding the filter to the measurement chain.
 8. Since non-restricted band peak emissions are less than the average limit, they also comply with the -27dBm/MHz (68.2dBuV/m) limit.

HARMONICS AND SPURIOUS EMISSIONS (MID CHANNEL, VERTICAL)

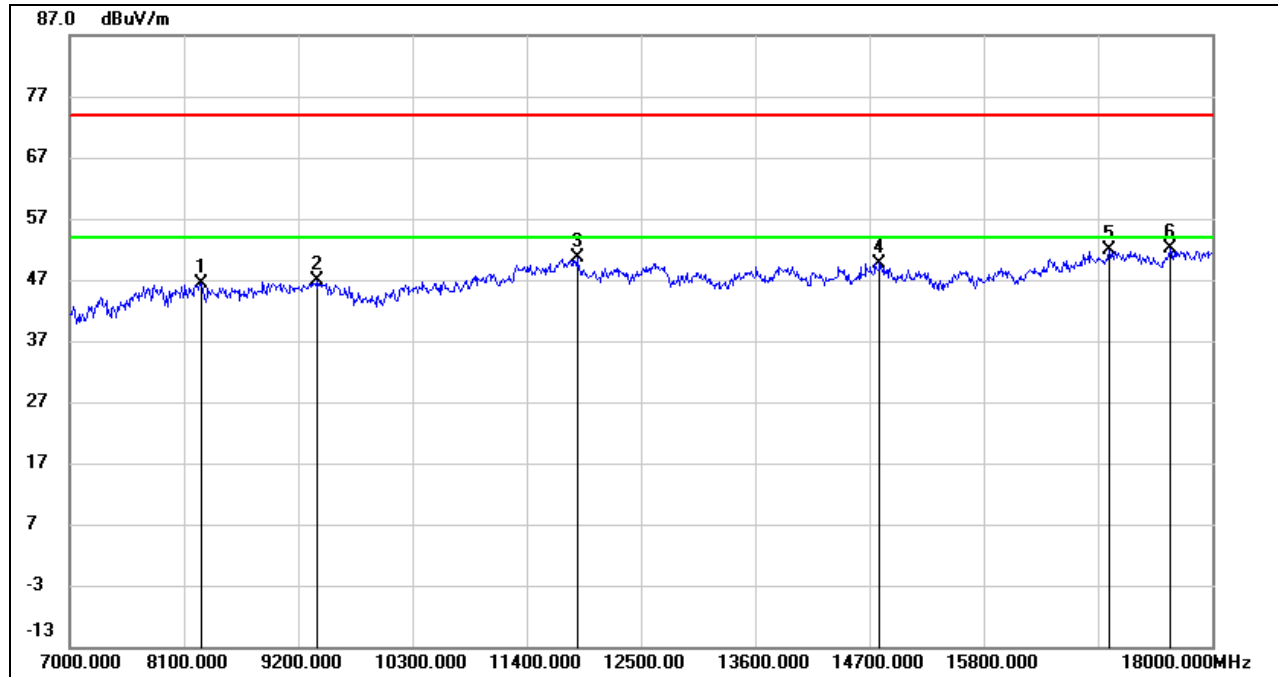

No.	Frequency (MHz)	Reading (dBuV)	Correct (dB/m)	Result (dBuV/m)	Limit (dBuV/m)	Margin (dB)	Remark
1	8265.000	37.34	9.11	46.45	74.00	-27.55	peak
2	9376.000	36.72	10.19	46.91	74.00	-27.09	peak
3	11884.000	35.04	15.49	50.53	74.00	-23.47	peak
4	14799.000	32.95	16.80	49.75	74.00	-24.25	peak
5	17010.000	31.54	20.27	51.81	74.00	-22.19	peak
6	17593.000	30.93	21.15	52.08	74.00	-21.92	peak

Note: 1. Measurement = Reading Level + Correct Factor.
 2. If Peak Result complies with AV limit, AV Result is deemed to comply with AV limit.
 3. Peak: Peak detector.
 4. AVG: $VBW=1/Ton$, where: Ton is the transmitting duration.
 5. For the transmitting duration, please refer to clause 7.1.
 6. Filter losses were only considered in the spurious frequency bands and the authorized band was not corrected for High Pass Filter losses.
 7. Proper operation of the transmitter prior to adding the filter to the measurement chain.
 8. Since non-restricted band peak emissions are less than the average limit, they also comply with the -27dBm/MHz (68.2dBuV/m) limit.

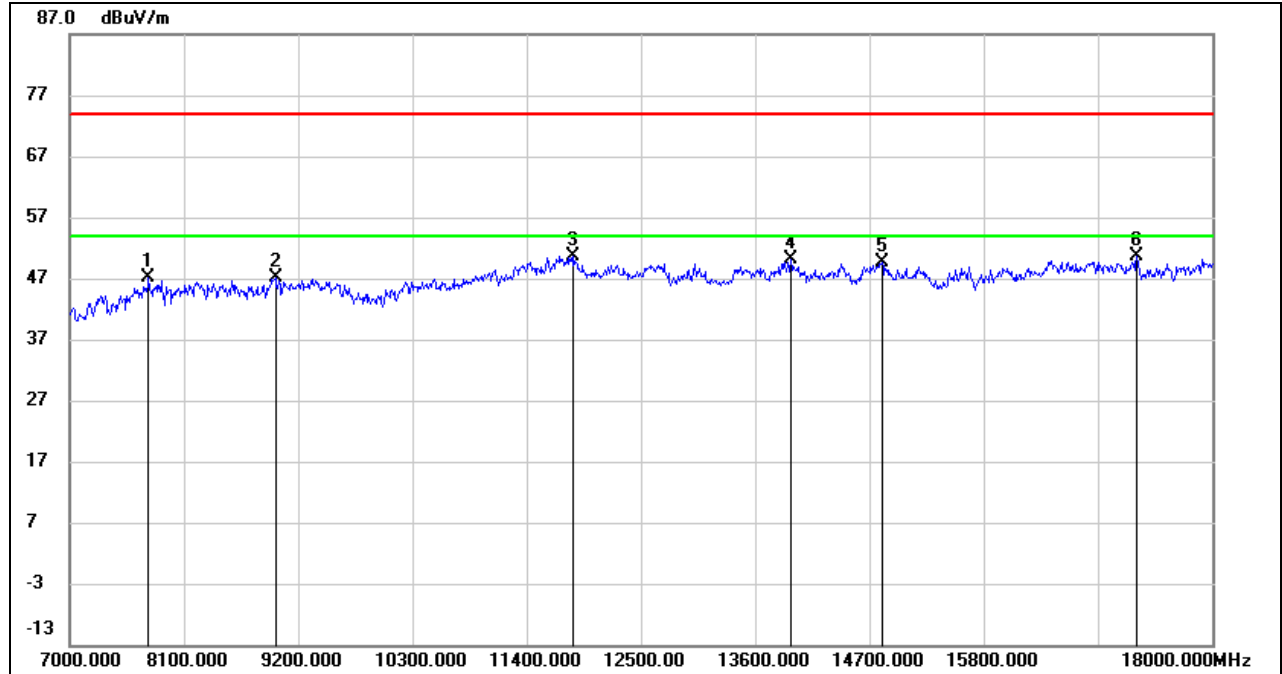
**HARMONICS AND SPURIOUS EMISSIONS (HIGH CHANNEL, HORIZONTAL)**

No.	Frequency (MHz)	Reading (dBuV)	Correct (dB/m)	Result (dBuV/m)	Limit (dBuV/m)	Margin (dB)	Remark
1	7759.000	39.07	8.09	47.16	74.00	-26.84	peak
2	8980.000	36.81	10.41	47.22	74.00	-26.78	peak
3	11851.000	35.13	15.53	50.66	74.00	-23.34	peak
4	13941.000	33.21	16.88	50.09	74.00	-23.91	peak
5	14821.000	32.85	16.81	49.66	74.00	-24.34	peak
6	17274.000	29.73	20.93	50.66	74.00	-23.34	peak

Note: 1. Measurement = Reading Level + Correct Factor.

2. If Peak Result complies with AV limit, AV Result is deemed to comply with AV limit.

3. Peak: Peak detector.

4. AVG: $VBW=1/Ton$, where: Ton is the transmitting duration.

5. For the transmitting duration, please refer to clause 7.1.

6. Filter losses were only considered in the spurious frequency bands and the authorized band was not corrected for High Pass Filter losses.

7. Proper operation of the transmitter prior to adding the filter to the measurement chain.

8. Since non-restricted band peak emissions are less than the average limit, they also comply with the -27dBm/MHz (68.2dBuV/m) limit.

HARMONICS AND SPURIOUS EMISSIONS (HIGH CHANNEL, VERTICAL)

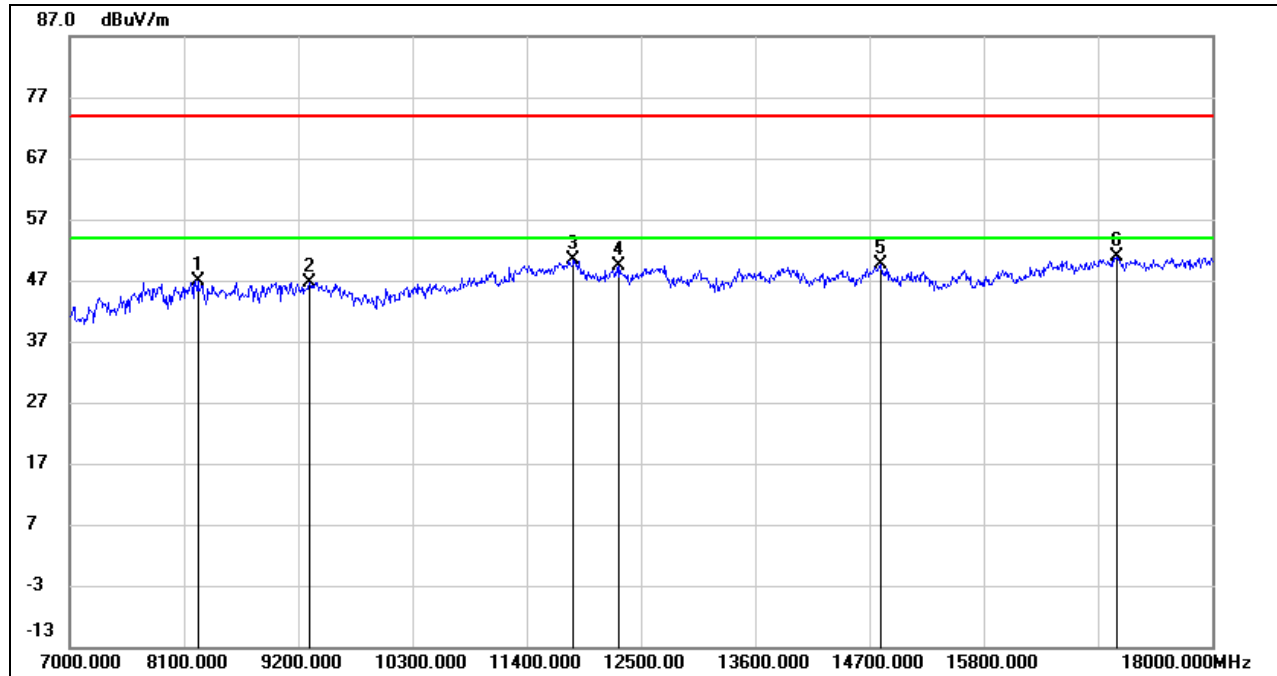

No.	Frequency (MHz)	Reading (dBuV)	Correct (dB/m)	Result (dBuV/m)	Limit (dBuV/m)	Margin (dB)	Remark
1	8232.000	37.75	9.23	46.98	74.00	-27.02	peak
2	9310.000	36.87	9.86	46.73	74.00	-27.27	peak
3	11851.000	34.94	15.53	50.47	74.00	-23.53	peak
4	12291.000	34.21	15.29	49.50	74.00	-24.50	peak
5	14810.000	32.83	16.80	49.63	74.00	-24.37	peak
6	17076.000	30.39	20.54	50.93	74.00	-23.07	peak

- Note:
1. Measurement = Reading Level + Correct Factor.
 2. If Peak Result complies with AV limit, AV Result is deemed to comply with AV limit.
 3. Peak: Peak detector.
 4. AVG: $VBW=1/Ton$, where: Ton is the transmitting duration.
 5. For the transmitting duration, please refer to clause 7.1.
 6. Filter losses were only considered in the spurious frequency bands and the authorized band was not corrected for High Pass Filter losses.
 7. Proper operation of the transmitter prior to adding the filter to the measurement chain.
 8. Since non-restricted band peak emissions are less than the average limit, they also comply with the -27dBm/MHz (68.2dBuV/m) limit.

8.3.7. 5G SRD 40MHz MODE

UNII-3 BAND

HARMONICS AND SPURIOUS EMISSIONS (LOW CHANNEL, HORIZONTAL)

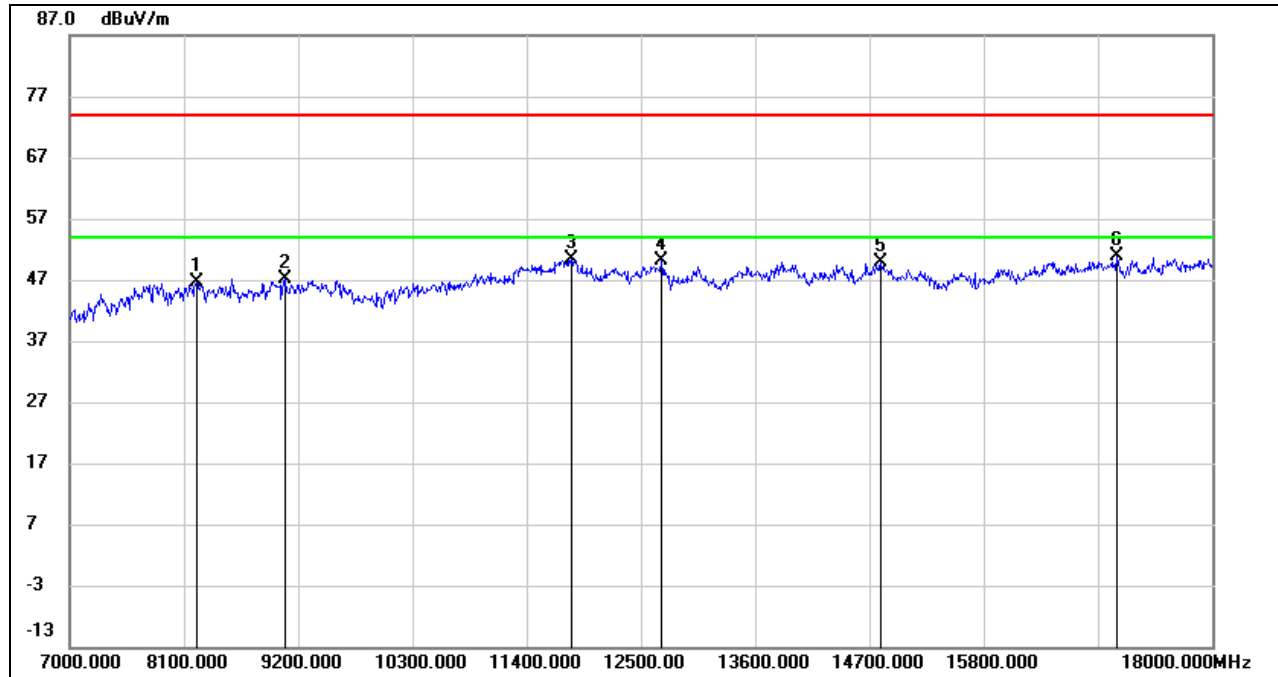

No.	Frequency (MHz)	Reading (dBuV)	Correct (dB/m)	Result (dBuV/m)	Limit (dBuV/m)	Margin (dB)	Remark
1	8221.000	37.45	9.28	46.73	74.00	-27.27	peak
2	9079.000	36.95	10.10	47.05	74.00	-26.95	peak
3	11829.000	34.88	15.57	50.45	74.00	-23.55	peak
4	12698.000	34.55	15.47	50.02	74.00	-23.98	peak
5	14810.000	33.17	16.80	49.97	74.00	-24.03	peak
6	17076.000	30.27	20.54	50.81	74.00	-23.19	peak

- Note:
1. Measurement = Reading Level + Correct Factor.
 2. If Peak Result complies with AV limit, AV Result is deemed to comply with AV limit.
 3. Peak: Peak detector.
 4. AVG: $VBW=1/Ton$, where: Ton is the transmitting duration.
 5. For the transmitting duration, please refer to clause 7.1.
 6. Filter losses were only considered in the spurious frequency bands and the authorized band was not corrected for High Pass Filter losses.
 7. Proper operation of the transmitter prior to adding the filter to the measurement chain.
 8. Since non-restricted band peak emissions are less than the average limit, they also comply with the -27dBm/MHz (68.2dBuV/m) limit.

HARMONICS AND SPURIOUS EMISSIONS (LOW CHANNEL, VERTICAL)

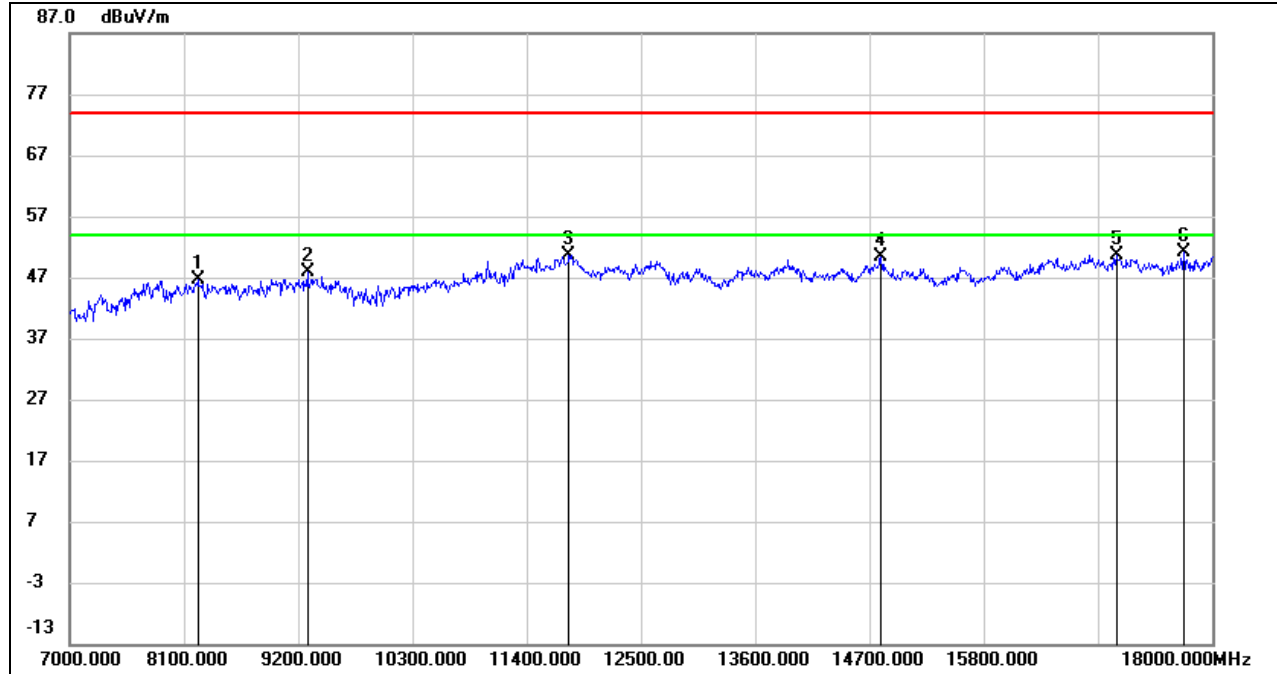

No.	Frequency (MHz)	Reading (dBuV)	Correct (dB/m)	Result (dBuV/m)	Limit (dBuV/m)	Margin (dB)	Remark
1	8232.000	37.29	9.23	46.52	74.00	-27.48	peak
2	9288.000	38.02	9.74	47.76	74.00	-26.24	peak
3	11807.000	35.09	15.61	50.70	74.00	-23.30	peak
4	14810.000	33.66	16.80	50.46	74.00	-23.54	peak
5	17076.000	30.08	20.54	50.62	74.00	-23.38	peak
6	17725.000	29.03	22.13	51.16	74.00	-22.84	peak

- Note: 1. Measurement = Reading Level + Correct Factor.
 2. If Peak Result complies with AV limit, AV Result is deemed to comply with AV limit.
 3. Peak: Peak detector.
 4. AVG: $VBW=1/Ton$, where: Ton is the transmitting duration.
 5. For the transmitting duration, please refer to clause 7.1.
 6. Filter losses were only considered in the spurious frequency bands and the authorized band was not corrected for High Pass Filter losses.
 7. Proper operation of the transmitter prior to adding the filter to the measurement chain.
 8. Since non-restricted band peak emissions are less than the average limit, they also comply with the -27dBm/MHz (68.2dBuV/m) limit.

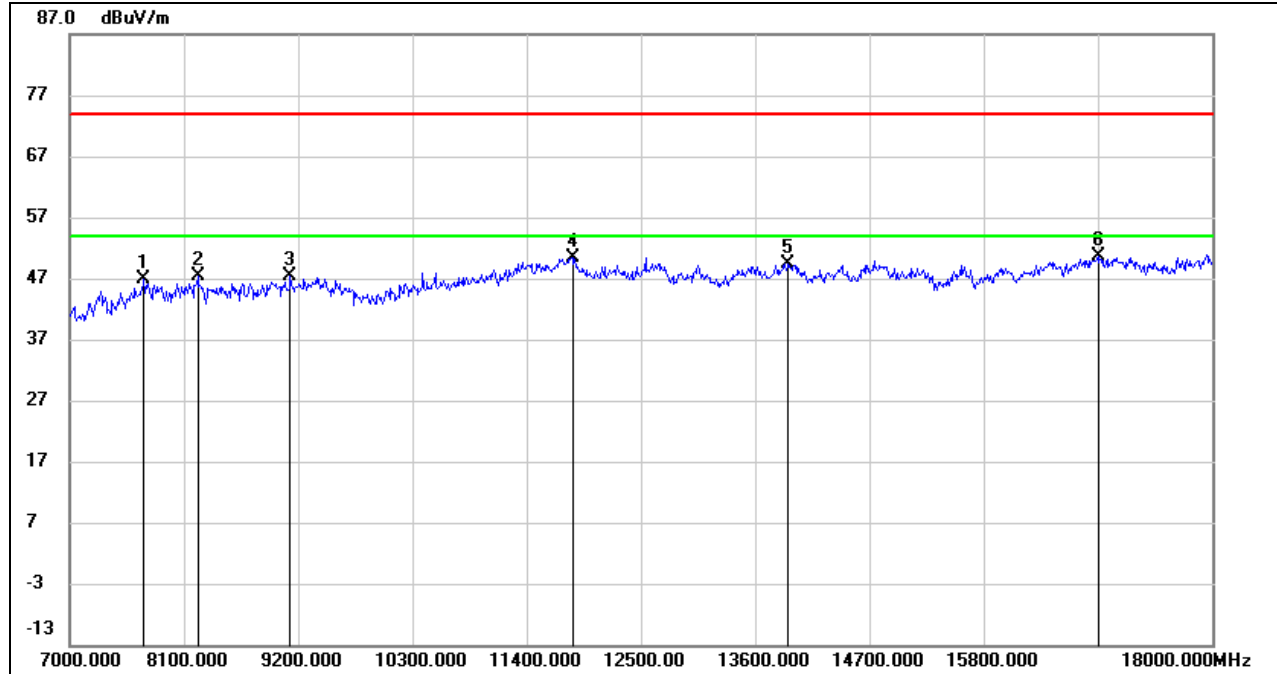
**HARMONICS AND SPURIOUS EMISSIONS (MID CHANNEL, HORIZONTAL)**

No.	Frequency (MHz)	Reading (dBuV)	Correct (dB/m)	Result (dBuV/m)	Limit (dBuV/m)	Margin (dB)	Remark
1	7715.000	38.89	7.92	46.81	74.00	-27.19	peak
2	8232.000	38.27	9.23	47.50	74.00	-26.50	peak
3	9123.000	37.66	9.81	47.47	74.00	-26.53	peak
4	11840.000	34.90	15.56	50.46	74.00	-23.54	peak
5	13919.000	32.42	16.89	49.31	74.00	-24.69	peak
6	16900.000	30.60	19.98	50.58	74.00	-23.42	peak

Note: 1. Measurement = Reading Level + Correct Factor.

2. If Peak Result complies with AV limit, AV Result is deemed to comply with AV limit.

3. Peak: Peak detector.

4. AVG: $VBW=1/Ton$, where: Ton is the transmitting duration.

5. For the transmitting duration, please refer to clause 7.1.

6. Filter losses were only considered in the spurious frequency bands and the authorized band was not corrected for High Pass Filter losses.

7. Proper operation of the transmitter prior to adding the filter to the measurement chain.

8. Since non-restricted band peak emissions are less than the average limit, they also comply with the -27dBm/MHz (68.2dBuV/m) limit.

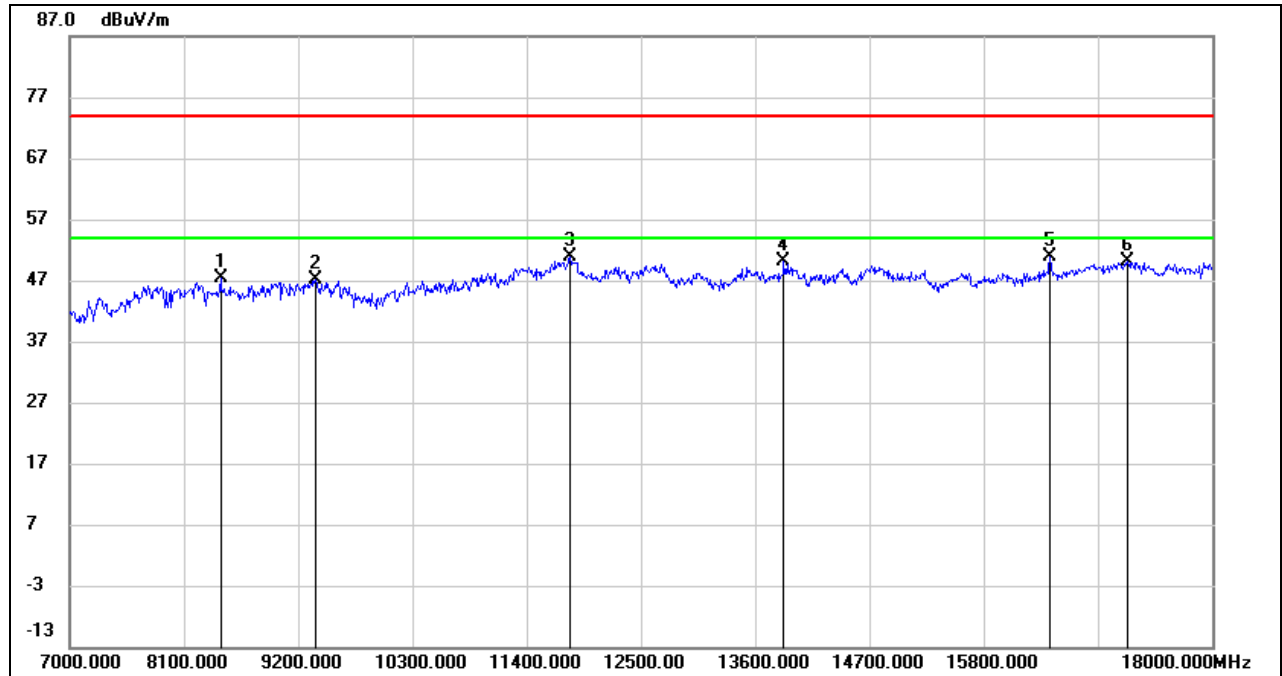
**HARMONICS AND SPURIOUS EMISSIONS (MID CHANNEL, VERTICAL)**

No.	Frequency (MHz)	Reading (dBuV)	Correct (dB/m)	Result (dBuV/m)	Limit (dBuV/m)	Margin (dB)	Remark
1	8452.000	38.74	8.56	47.30	74.00	-26.70	peak
2	9365.000	36.97	10.13	47.10	74.00	-26.90	peak
3	11818.000	35.33	15.58	50.91	74.00	-23.09	peak
4	13875.000	33.29	16.92	50.21	74.00	-23.79	peak
5	16438.000	31.95	18.86	50.81	74.00	-23.19	peak
6	17186.000	29.17	20.98	50.15	74.00	-23.85	peak

- Note: 1. Measurement = Reading Level + Correct Factor.
 2. If Peak Result complies with AV limit, AV Result is deemed to comply with AV limit.
 3. Peak: Peak detector.
 4. AVG: $VBW=1/Ton$, where: Ton is the transmitting duration.
 5. For the transmitting duration, please refer to clause 7.1.
 6. Filter losses were only considered in the spurious frequency bands and the authorized band was not corrected for High Pass Filter losses.
 7. Proper operation of the transmitter prior to adding the filter to the measurement chain.
 8. Since non-restricted band peak emissions are less than the average limit, they also comply with the -27dBm/MHz (68.2dBuV/m) limit.

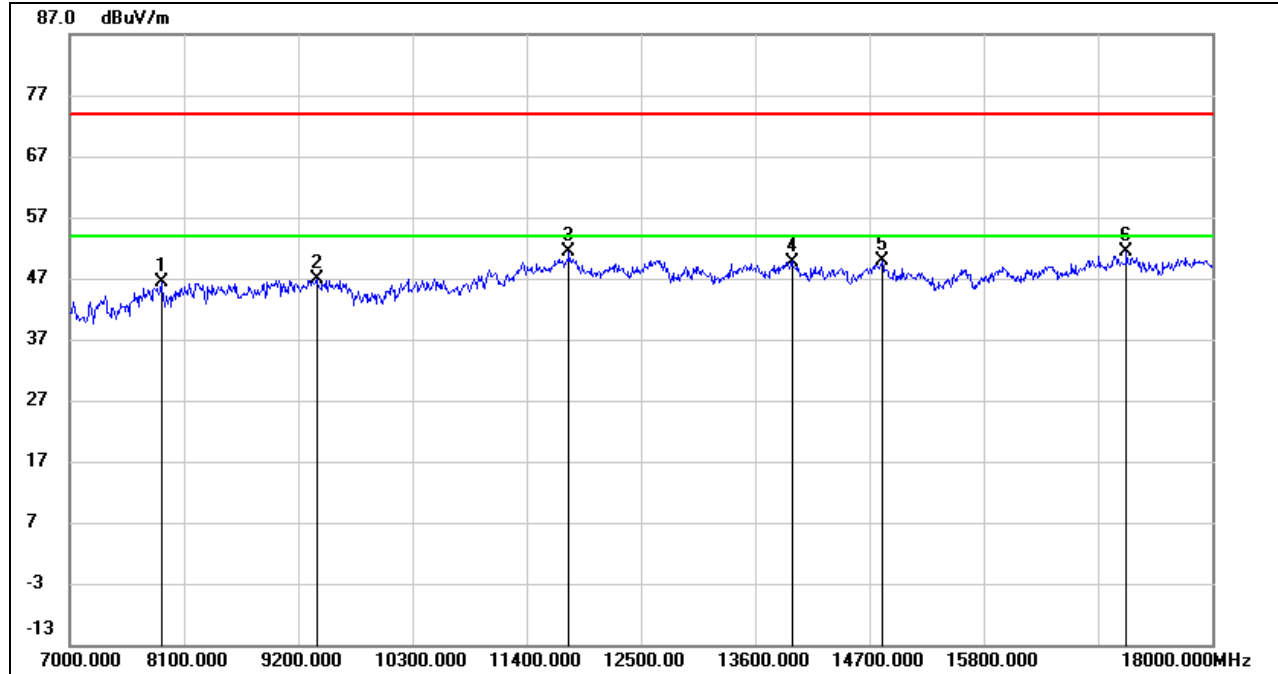
**HARMONICS AND SPURIOUS EMISSIONS (HIGH CHANNEL, HORIZONTAL)**

No.	Frequency (MHz)	Reading (dBuV)	Correct (dB/m)	Result (dBuV/m)	Limit (dBuV/m)	Margin (dB)	Remark
1	7880.000	38.40	8.01	46.41	74.00	-27.59	peak
2	9376.000	36.70	10.19	46.89	74.00	-27.11	peak
3	11807.000	35.69	15.61	51.30	74.00	-22.70	peak
4	13952.000	32.87	16.88	49.75	74.00	-24.25	peak
5	14821.000	33.10	16.81	49.91	74.00	-24.09	peak
6	17175.000	30.50	20.94	51.44	74.00	-22.56	peak

- Note: 1. Measurement = Reading Level + Correct Factor.
 2. If Peak Result complies with AV limit, AV Result is deemed to comply with AV limit.
 3. Peak: Peak detector.
 4. AVG: $VBW=1/Ton$, where: Ton is the transmitting duration.
 5. For the transmitting duration, please refer to clause 7.1.
 6. Filter losses were only considered in the spurious frequency bands and the authorized band was not corrected for High Pass Filter losses.
 7. Proper operation of the transmitter prior to adding the filter to the measurement chain.
 8. Since non-restricted band peak emissions are less than the average limit, they also comply with the -27dBm/MHz (68.2dBuV/m) limit.

HARMONICS AND SPURIOUS EMISSIONS (HIGH CHANNEL, VERTICAL)

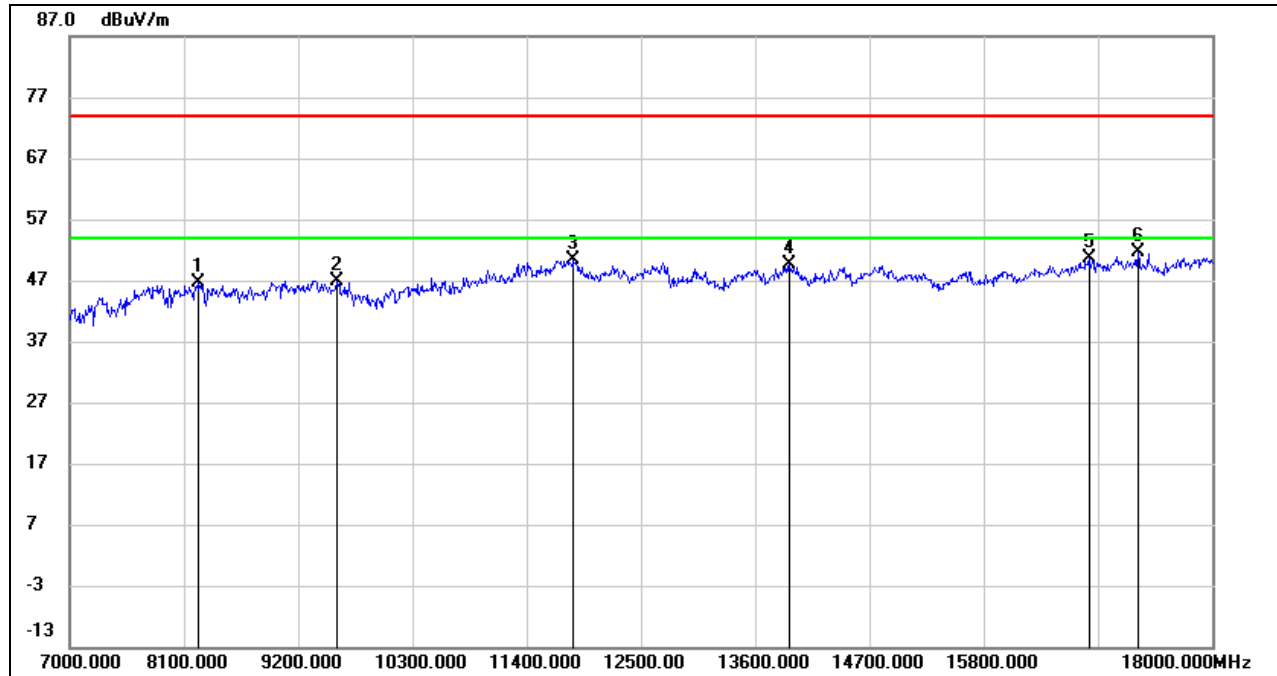

No.	Frequency (MHz)	Reading (dBuV)	Correct (dB/m)	Result (dBuV/m)	Limit (dBuV/m)	Margin (dB)	Remark
1	8232.000	37.35	9.23	46.58	74.00	-27.42	peak
2	9574.000	36.50	10.46	46.96	74.00	-27.04	peak
3	11851.000	34.93	15.53	50.46	74.00	-23.54	peak
4	13930.000	32.69	16.89	49.58	74.00	-24.42	peak
5	16812.000	30.92	19.77	50.69	74.00	-23.31	peak
6	17285.000	30.59	20.92	51.51	74.00	-22.49	peak

- Note: 1. Measurement = Reading Level + Correct Factor.
 2. If Peak Result complies with AV limit, AV Result is deemed to comply with AV limit.
 3. Peak: Peak detector.
 4. AVG: $VBW=1/Ton$, where: Ton is the transmitting duration.
 5. For the transmitting duration, please refer to clause 7.1.
 6. Filter losses were only considered in the spurious frequency bands and the authorized band was not corrected for High Pass Filter losses.
 7. Proper operation of the transmitter prior to adding the filter to the measurement chain.
 8. Since non-restricted band peak emissions are less than the average limit, they also comply with the -27dBm/MHz (68.2dBuV/m) limit.

Note: All the modes and antennas had been tested, but only the worst data was recorded in the report.

8.4. SPURIOUS EMISSIONS (18 GHz ~ 26 GHz)

8.4.1. 5G SRD 1.4MHz MODE

SPURIOUS EMISSIONS (UNII-3 BAND LOW CHANNEL, HORIZONTAL, WORST-CASE CONFIGURATION)

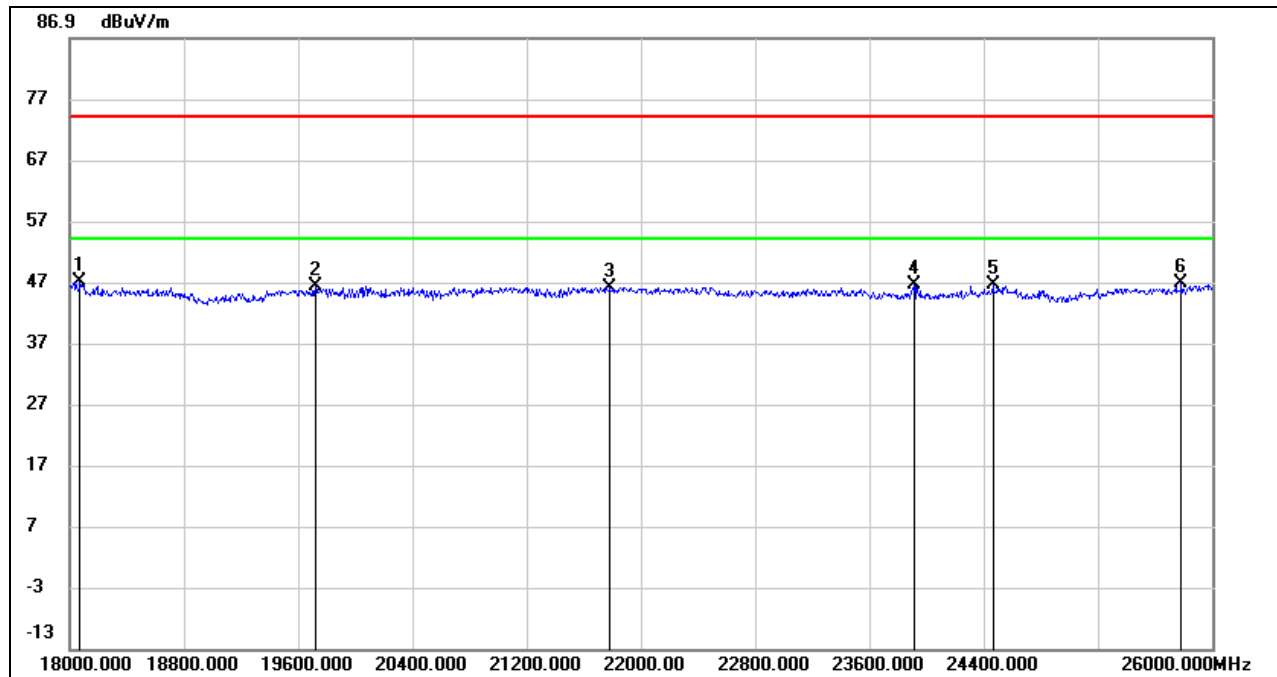

No.	Frequency (MHz)	Reading (dBuV)	Correct (dB/m)	Result (dBuV/m)	Limit (dBuV/m)	Margin (dB)	Remark
1	18072.000	51.05	-4.02	47.03	74.00	-26.97	peak
2	19720.000	50.58	-4.39	46.19	74.00	-27.81	peak
3	21784.000	51.96	-5.82	46.14	74.00	-27.86	peak
4	23912.000	50.82	-4.23	46.59	74.00	-27.41	peak
5	24464.000	49.28	-2.74	46.54	74.00	-27.46	peak
6	25784.000	48.23	-1.49	46.74	74.00	-27.26	peak

Note: 1. Measurement = Reading Level + Correct Factor.
 2. If Peak Result complies with AV limit, AV Result is deemed to comply with AV limit.
 3. Peak: Peak detector.
 4. The preamplifier only effect to the above 18GHz signal and no filter added to the measurement chain.

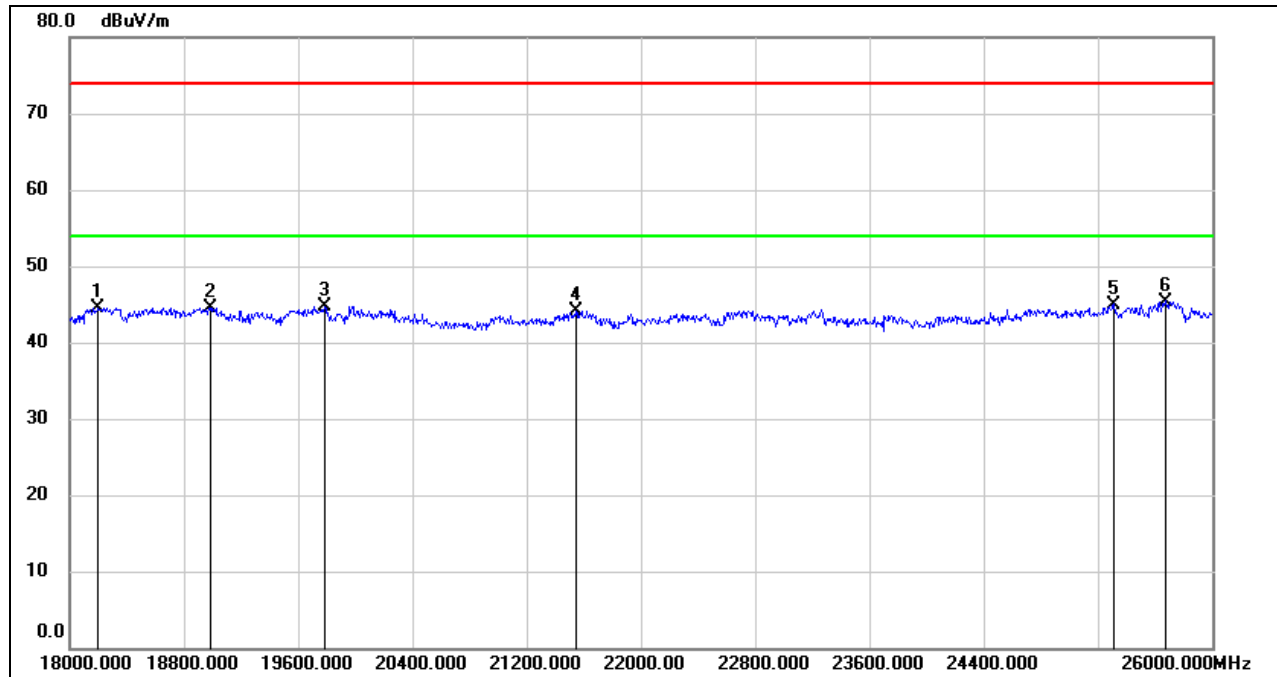
**SPURIOUS EMISSIONS (LOW CHANNEL, VERTICAL, WORST-CASE CONFIGURATION)**

No.	Frequency (MHz)	Reading (dBuV)	Correct (dB/m)	Result (dBuV/m)	Limit (dBuV/m)	Margin (dB)	Remark
1	18200.000	50.08	-5.52	44.56	74.00	-29.44	peak
2	18984.000	49.79	-5.23	44.56	74.00	-29.44	peak
3	19784.000	50.07	-5.28	44.79	74.00	-29.21	peak
4	21544.000	48.76	-4.63	44.13	74.00	-29.87	peak
5	25312.000	46.70	-1.70	45.00	74.00	-29.00	peak
6	25672.000	46.37	-0.97	45.40	74.00	-28.60	peak

Note: 1. Measurement = Reading Level + Correct Factor.

2. If Peak Result complies with AV limit, AV Result is deemed to comply with AV limit.

3. Peak: Peak detector.

4. The preamplifier only effect to the above 18GHz signal and no filter added to the measurement chain.

Note: All the modes and channels had been tested, but only the worst data was recorded in the report.

8.5. SPURIOUS EMISSIONS (26 GHz ~ 40 GHz)

8.5.1. 5G SRD 1.4MHz MODE

SPURIOUS EMISSIONS (UNII-3 BAND LOW CHANNEL, HORIZONTAL, WORST-CASE CONFIGURATION)

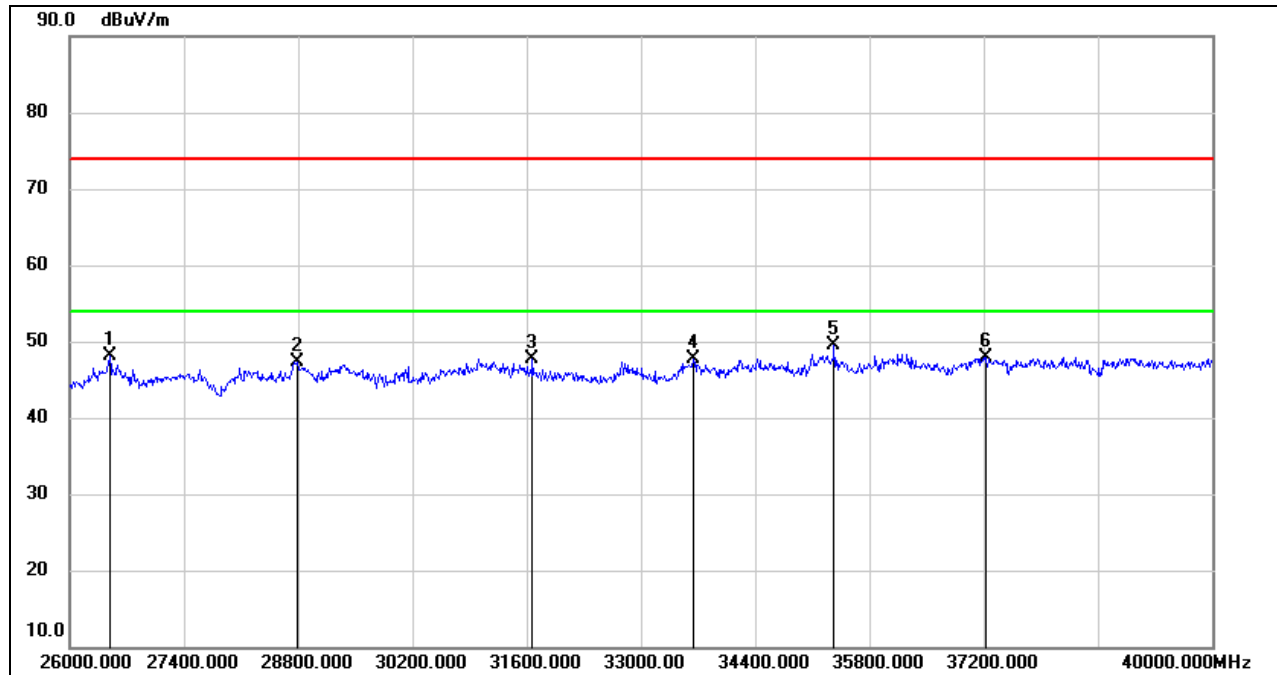

No.	Frequency (MHz)	Reading (dBuV)	Correct (dB/m)	Result (dBuV/m)	Limit (dBuV/m)	Margin (dB)	Remark
1	26490.000	52.79	-4.74	48.05	74.00	-25.95	peak
2	28786.000	47.99	-0.64	47.35	74.00	-26.65	peak
3	31670.000	48.86	-1.21	47.65	74.00	-26.35	peak
4	33644.000	47.31	0.42	47.73	74.00	-26.27	peak
5	35366.000	46.90	2.59	49.49	74.00	-24.51	peak
6	37228.000	44.73	3.14	47.87	74.00	-26.13	peak

Note: 1. Measurement = Reading Level + Correct Factor.

2. If Peak Result complies with AV limit, AV Result is deemed to comply with AV limit.

3. Peak: Peak detector.

4. Proper operation of the transmitter prior to adding the filter to the measurement chain.

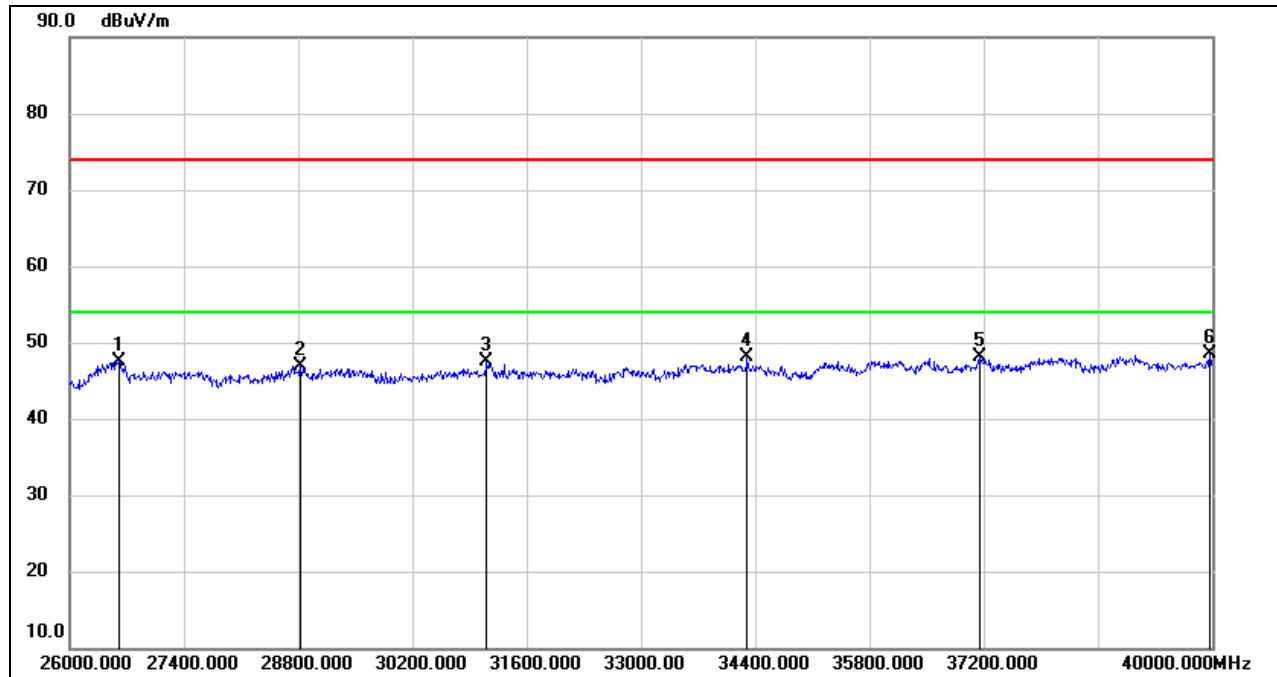
**SPURIOUS EMISSIONS (LOW CHANNEL, VERTICAL, WORST-CASE CONFIGURATION)**

No.	Frequency (MHz)	Reading (dBuV)	Correct (dB/m)	Result (dBuV/m)	Limit (dBuV/m)	Margin (dB)	Remark
1	26602.000	52.28	-4.80	47.48	74.00	-26.52	peak
2	28828.000	47.63	-0.79	46.84	74.00	-27.16	peak
3	31110.000	48.33	-0.75	47.58	74.00	-26.42	peak
4	34302.000	46.95	1.10	48.05	74.00	-25.95	peak
5	37158.000	44.84	3.17	48.01	74.00	-25.99	peak
6	39972.000	43.45	5.13	48.58	74.00	-25.42	peak

- Note: 1. Measurement = Reading Level + Correct Factor.
 2. If Peak Result complies with AV limit, AV Result is deemed to comply with AV limit.
 3. Peak: Peak detector.
 4. Proper operation of the transmitter prior to adding the filter to the measurement chain.

Note: All the modes and channels had been tested, but only the worst data was recorded in the report.



8.6. SPURIOUS EMISSIONS (30 MHz ~ 1 GHz)

8.6.1. 5G SRD 1.4MHz MODE

TEST RESULTS (WORST CASE)

SPURIOUS EMISSIONS (UNII-3 BAND LOW CHANNEL, HORIZONTAL, WORST-CASE CONFIGURATION)

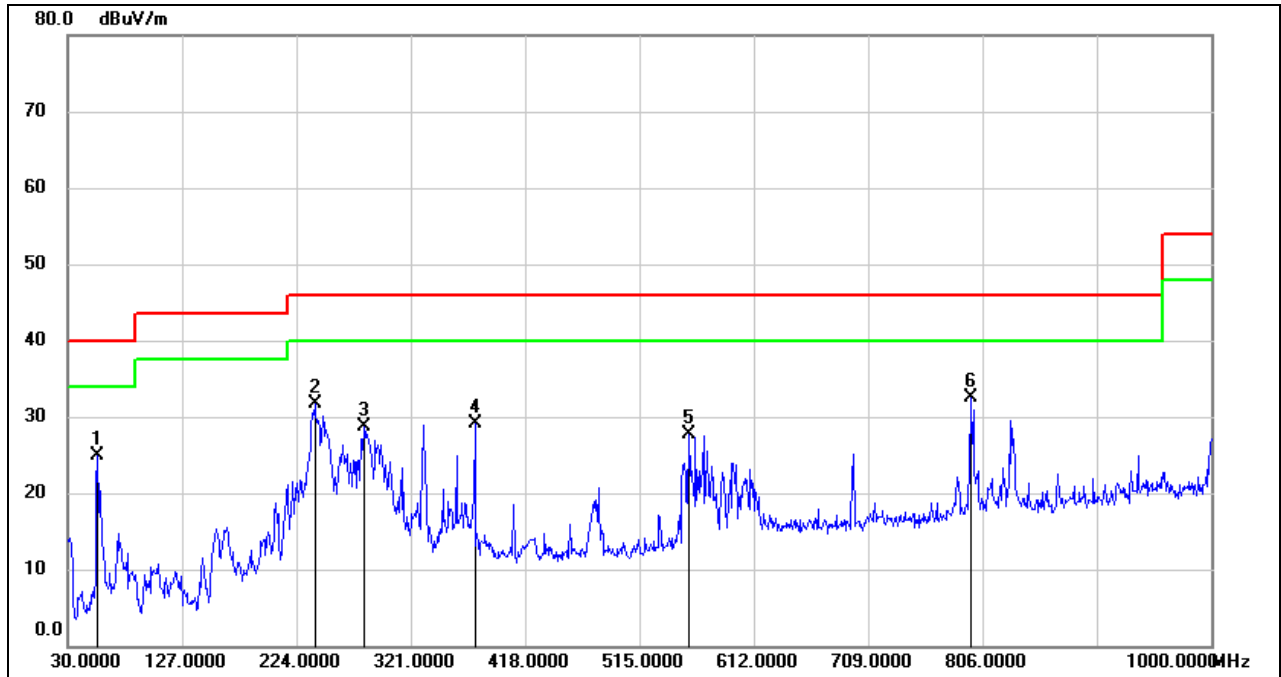

No.	Frequency (MHz)	Reading (dBuV)	Correct (dB/m)	Result (dBuV/m)	Limit (dBuV/m)	Margin (dB)	Remark
1	55.2200	45.55	-20.63	24.92	40.00	-15.08	QP
2	239.5200	50.81	-19.16	31.65	46.00	-14.35	QP
3	281.2300	45.29	-16.59	28.70	46.00	-17.30	QP
4	375.3200	42.85	-13.79	29.06	46.00	-16.94	QP
5	556.7100	38.11	-10.38	27.73	46.00	-18.27	QP
6	796.3000	39.89	-7.35	32.54	46.00	-13.46	QP

- Note: 1. Result Level = Read Level + Correct Factor.
 2. If Peak Result complies with QP limit, QP Result is deemed to comply with QP limit.
 3. Test setup: RBW: 120 kHz, VBW: 300 kHz, Sweep time: auto.



SPURIOUS EMISSIONS (UNII-3 BAND LOW CHANNEL, VERTICAL, WORST-CASE CONFIGURATION)

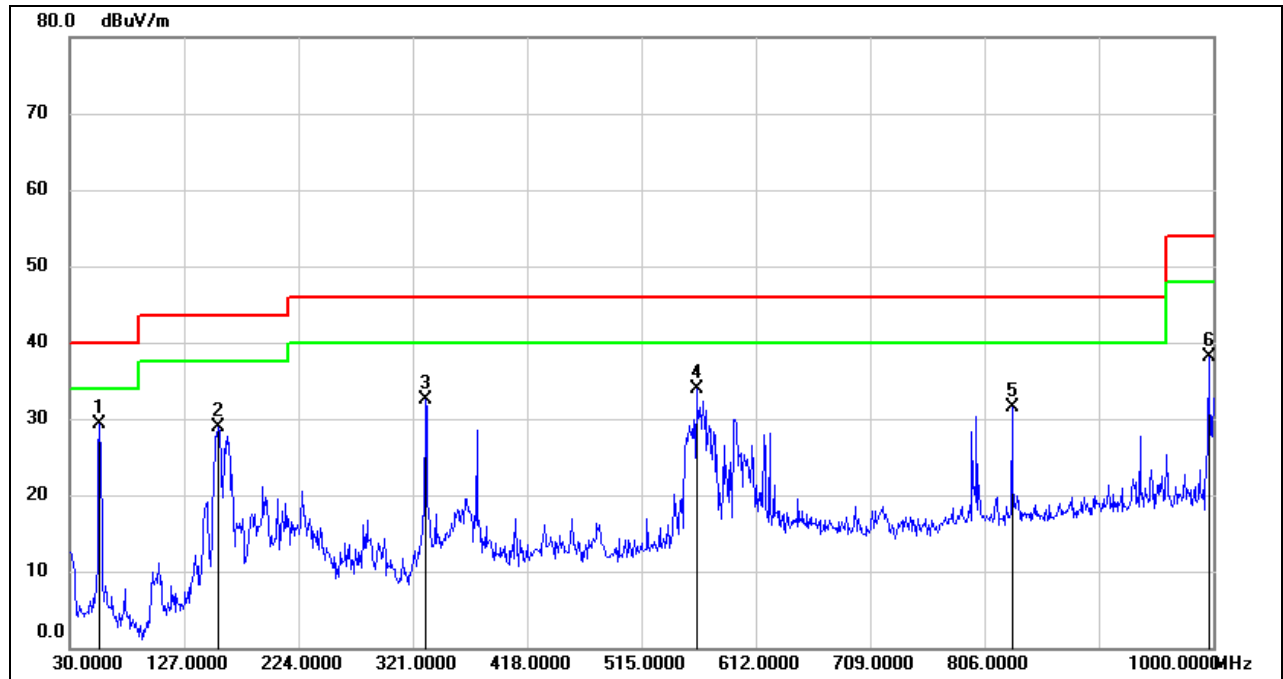

No.	Frequency (MHz)	Reading (dBuV)	Correct (dB/m)	Result (dBuV/m)	Limit (dBuV/m)	Margin (dB)	Remark
1	55.2200	49.96	-20.63	29.33	40.00	-10.67	QP
2	156.1000	46.85	-17.96	28.89	43.50	-14.61	QP
3	331.6700	47.07	-14.64	32.43	46.00	-13.57	QP
4	561.5600	44.18	-10.28	33.90	46.00	-12.10	QP
5	829.2800	38.10	-6.69	31.41	46.00	-14.59	QP
6	996.1200	42.25	-4.20	38.05	54.00	-15.95	QP

- Note: 1. Result Level = Read Level + Correct Factor.
 2. If Peak Result complies with QP limit, QP Result is deemed to comply with QP limit.
 3. Test setup: RBW: 120 kHz, VBW: 300 kHz, Sweep time: auto

Note: All the modes and channels had been tested, but only the worst data was recorded in the report.

8.7. SPURIOUS EMISSIONS BELOW 30 MHz

8.7.1. 5G SRD 1.4MHz MODE

SPURIOUS EMISSIONS (UNII-3 BAND LOW CHANNEL, LOOP ANTENNA FACE ON TO THE EUT, WORST-CASE CONFIGURATION)

9 kHz~ 150 kHz

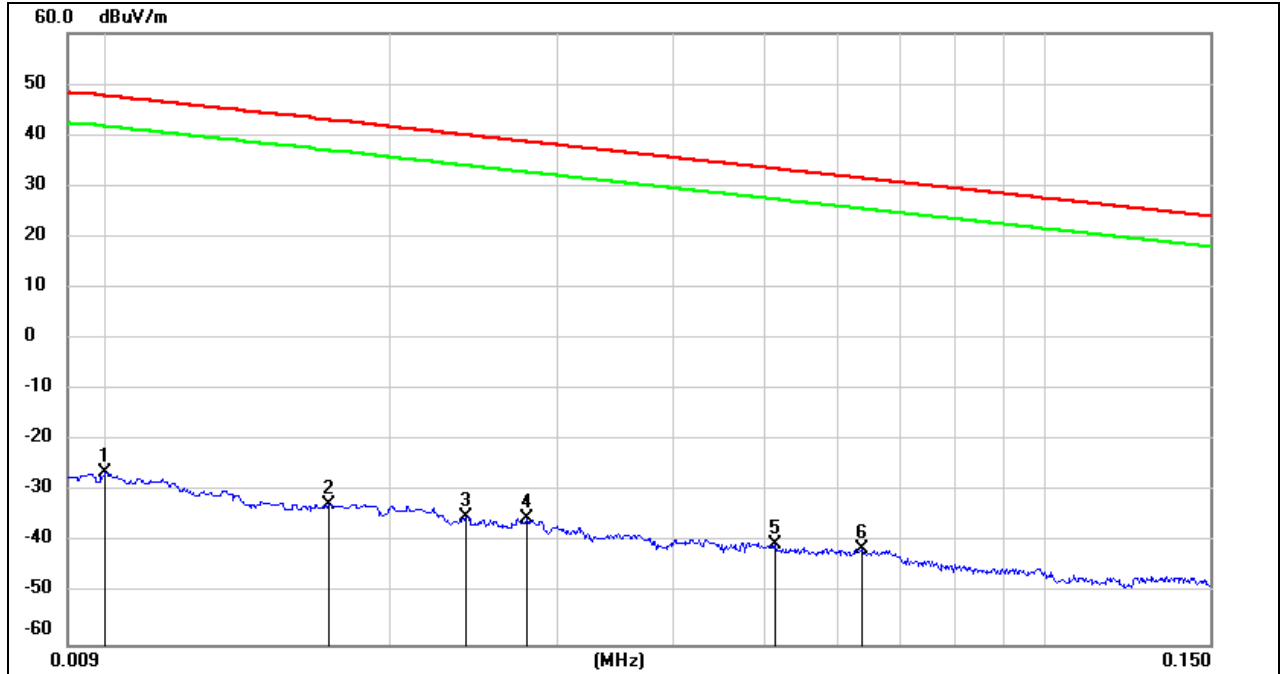

No.	Frequency (MHz)	Reading (dBuV)	Correct (dB/m)	FCC Result (dBuV/m)	FCC Limit (dBuV/m)	Margin (dB)	Remark
1	0.0100	75.22	-101.40	-26.18	47.6	-73.78	peak
2	0.0171	68.88	-101.36	-32.48	42.94	-75.42	peak
3	0.0240	66.32	-101.36	-35.04	40	-75.04	peak
4	0.0279	66.17	-101.38	-35.21	38.69	-73.90	peak
5	0.0514	61.18	-101.48	-40.3	33.38	-73.68	peak
6	0.0636	60.31	-101.54	-41.23	31.53	-72.76	peak

Note: 1. Measurement = Reading Level + Correct Factor.

2. If Peak Result complies with AV and QP limit, AV and QP Result are deemed to comply with AV limit.

3. All 3 polarizations (Horizontal, Face-on and Face-off) of the loop antenna had been tested, but only the worst data recorded in the report.

150 kHz ~ 490 kHz

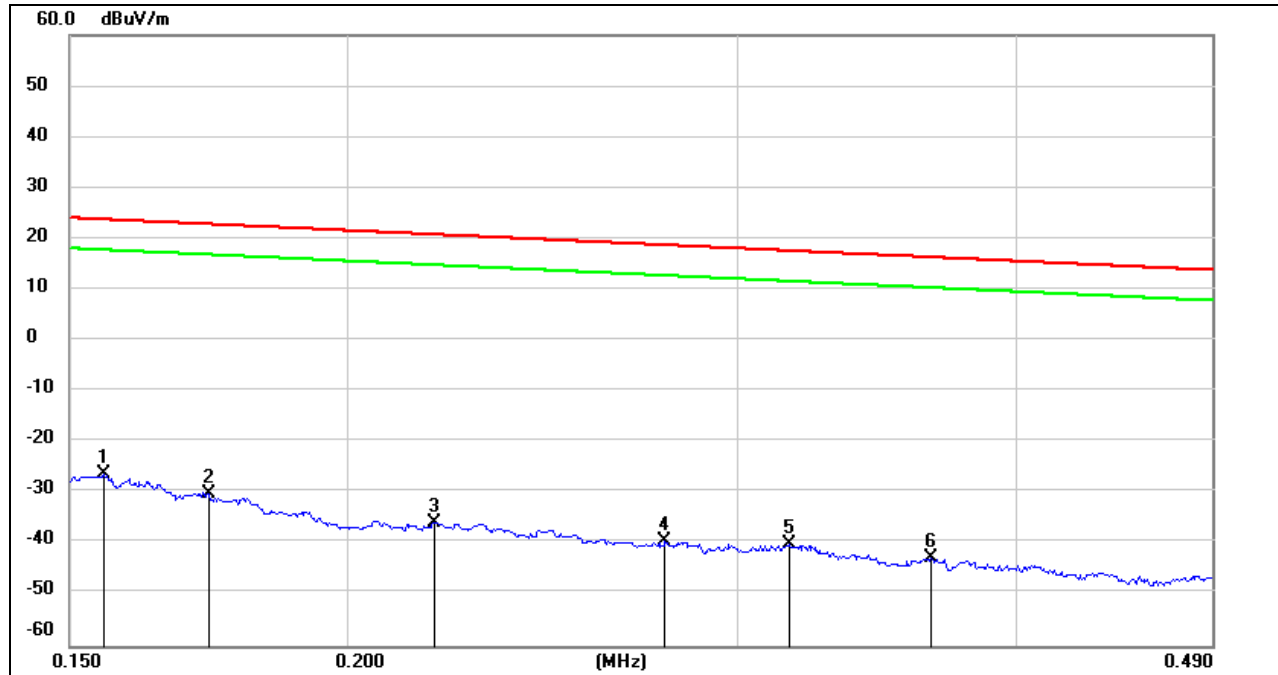

No.	Frequency (MHz)	Reading (dBuV)	Correct (dB/m)	FCC Result (dBuV/m)	FCC Limit (dBuV/m)	Margin (dB)	Remark
1	0.1554	75.27	-101.65	-26.38	23.77	-50.15	peak
2	0.1733	71.42	-101.67	-30.25	22.83	-53.08	peak
3	0.2190	65.77	-101.75	-35.98	20.79	-56.77	peak
4	0.2782	62.29	-101.83	-39.54	18.71	-58.25	peak
5	0.3163	61.70	-101.87	-40.17	17.6	-57.77	peak
6	0.3662	59.08	-101.93	-42.85	16.33	-59.18	peak

Note: 1. Measurement = Reading Level + Correct Factor.

2. If Peak Result complies with AV and QP limit, AV and QP Result are deemed to comply with AV limit.

3. All 3 polarizations (Horizontal, Face-on and Face-off) of the loop antenna had been tested, but only the worst data recorded in the report.

490 kHz ~ 30 MHz

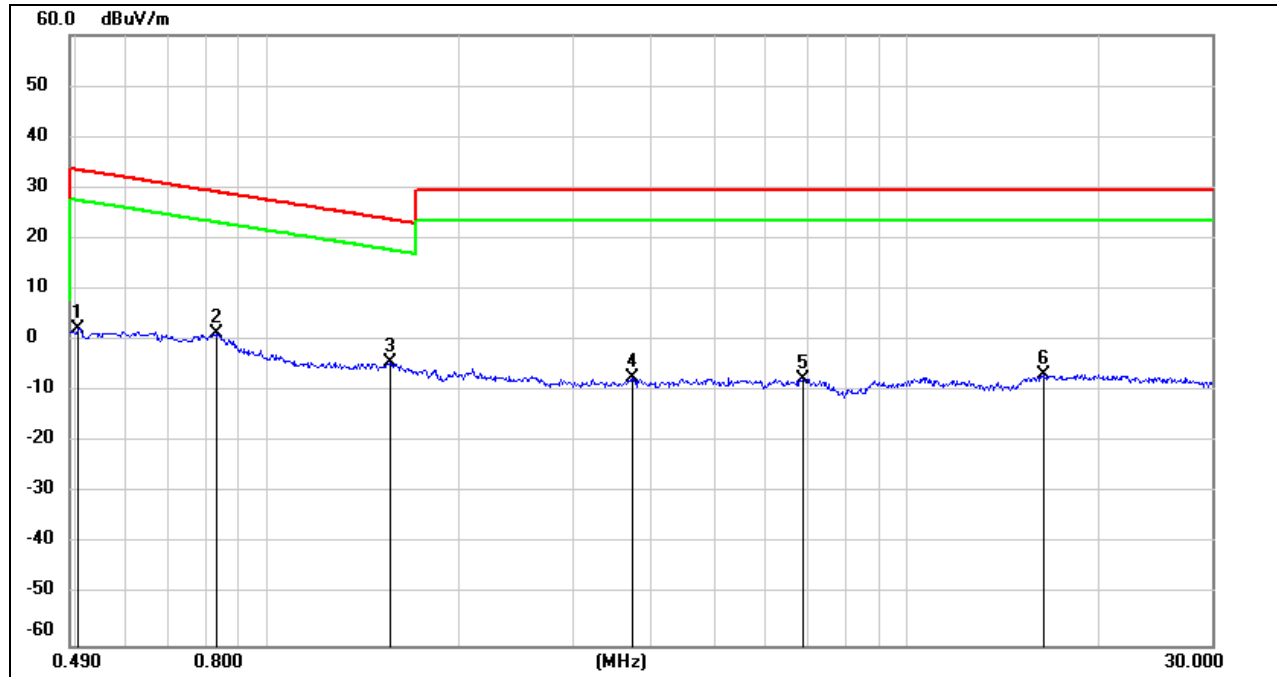

No.	Frequency (MHz)	Reading (dBuV)	Correct (dB/m)	FCC Result (dBuV/m)	FCC Limit (dBuV/m)	Margin (dB)	Remark
1	0.5039	64.44	-62.07	2.37	33.56	-31.19	peak
2	0.8296	63.44	-62.17	1.27	29.23	-27.96	peak
3	1.5564	57.68	-62.02	-4.34	23.76	-28.10	peak
4	3.7100	54.20	-61.41	-7.21	29.54	-36.75	peak
5	6.8936	53.59	-61.22	-7.63	29.54	-37.17	peak
6	16.3959	54.17	-60.96	-6.79	29.54	-36.33	peak

- Note: 1. Measurement = Reading Level + Correct Factor.
 2. If Peak Result complies with AV and QP limit, AV and QP Result are deemed to comply with AV limit.
 3. All 3 polarizations (Horizontal, Face-on and Face-off) of the loop antenna had been tested, but only the worst data recorded in the report.

Note: All the modes and channels had been tested, but only the worst data was recorded in the report.

9. AC POWER LINE CONDUCTED EMISSIONS

LIMITS

Please refer to CFR 47 FCC §15.207 (a)

FREQUENCY (MHz)	Quasi-peak	Average
0.15 -0.5	66 - 56 *	56 - 46 *
0.50 -5.0	56.00	46.00
5.0 -30.0	60.00	50.00

TEST SETUP AND PROCEDURE

Refer to ANSI C63.10-2013 clause 6.2.

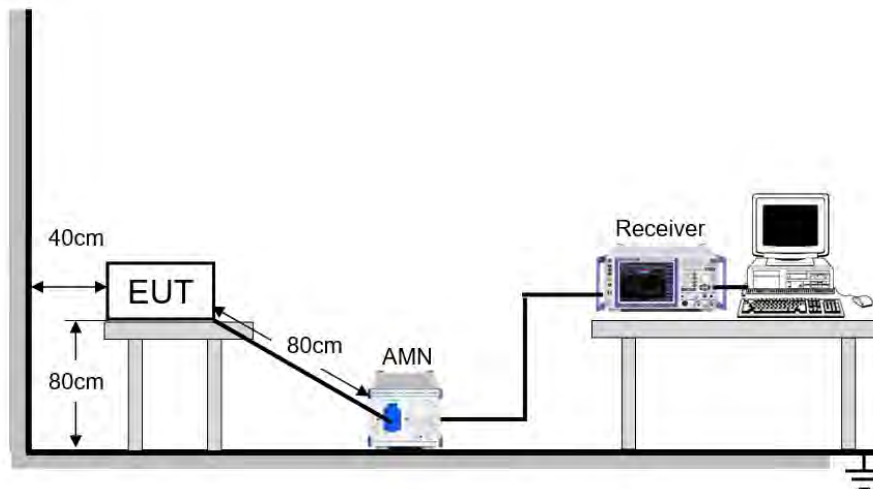

The EUT is put on a table of non-conducting material that is 80 cm high. The vertical conducting wall of shielding is located 40 cm to the rear of the EUT. The power line of the EUT is connected to the AC mains through a Artificial Mains Network (A.M.N.). A EMI Measurement Receiver (R&S Test Receiver ESR3) is used to test the emissions from both sides of AC line. According to the requirements in Section 6.2 of ANSI C63.10-2013. Conducted emissions from the EUT measured in the frequency range between 0.15 MHz and 30 MHz using CISPR Quasi-Peak and average detector mode. The bandwidth of EMI test receiver is set at 9 kHz.

The arrangement of the equipment is installed to meet the standards and operating in a manner, which tends to maximize its emission characteristics in a normal application.

TEST ENVIRONMENT

Temperature	24.3°C	Relative Humidity	64.4 %
Atmosphere Pressure	101 kPa	Test Voltage	AC120 V,60 Hz



RESULTS

9.1. 5G SRD 1.4MHz MODE

LINE N RESULTS (UNII-3 BAND LOW CHANNEL, WORST-CASE CONFIGURATION)

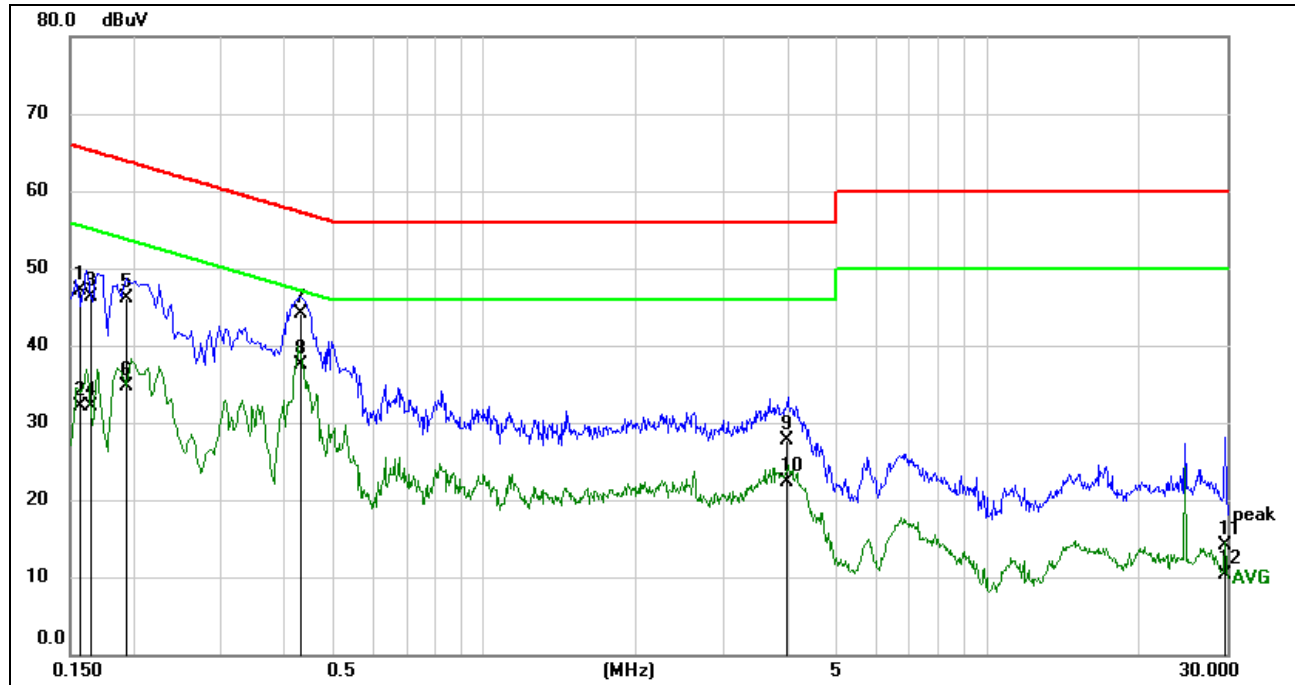

No.	Frequency (MHz)	Reading (dBuV)	Correct (dB)	Result (dBuV)	Limit (dBuV)	Margin (dB)	Remark
1	0.1573	37.58	9.59	47.17	65.61	-18.44	QP
2	0.1573	22.56	9.59	32.15	55.61	-23.46	AVG
3	0.1654	36.73	9.59	46.32	65.19	-18.87	QP
4	0.1654	22.56	9.59	32.15	55.19	-23.04	AVG
5	0.1930	36.52	9.59	46.11	63.91	-17.80	QP
6	0.1930	25.03	9.59	34.62	53.91	-19.29	AVG
7	0.4307	34.60	9.60	44.20	57.24	-13.04	QP
8	0.4307	27.91	9.60	37.51	47.24	-9.73	AVG
9	3.9874	18.17	9.60	27.77	56.00	-28.23	QP
10	3.9874	12.74	9.60	22.34	46.00	-23.66	AVG
11	29.7018	4.40	9.79	14.19	60.00	-45.81	QP
12	29.7018	0.49	9.79	10.28	50.00	-39.72	AVG

Note: 1. Result = Reading + Correct Factor.
 2. If QP Result complies with AV limit, AV Result is deemed to comply with AV limit.
 3. Test setup: RBW: 200 Hz (9 kHz ~ 150 kHz), 9 kHz (150 kHz ~ 30 MHz).
 4. Step size: 80 Hz (0.009 MHz ~ 0.15 MHz), 4 kHz (0.15 MHz ~ 30 MHz), Scan time: auto.

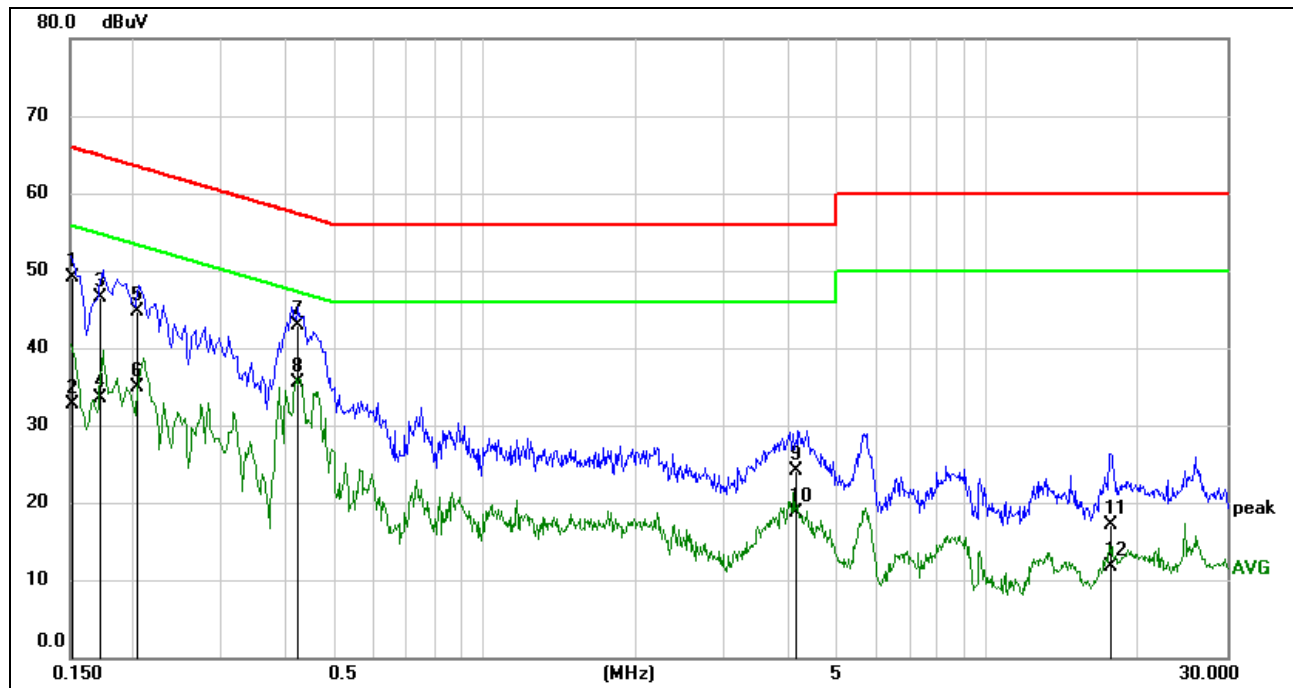
**LINE L RESULTS (UNII-3 BAND LOW CHANNEL, WORST-CASE CONFIGURATION)**

No.	Frequency (MHz)	Reading (dBuV)	Correct (dB)	Result (dBuV)	Limit (dBuV)	Margin (dB)	Remark
1	0.1519	39.43	9.59	49.02	65.90	-16.88	QP
2	0.1519	23.20	9.59	32.79	55.90	-23.11	AVG
3	0.1713	36.93	9.59	46.52	64.90	-18.38	QP
4	0.1713	23.92	9.59	33.51	54.90	-21.39	AVG
5	0.2029	35.13	9.59	44.72	63.49	-18.77	QP
6	0.2029	25.29	9.59	34.88	53.49	-18.61	AVG
7	0.4298	33.32	9.60	42.92	57.26	-14.34	QP
8	0.4298	25.81	9.60	35.41	47.26	-11.85	AVG
9	4.1795	14.41	9.60	24.01	56.00	-31.99	QP
10	4.1795	9.08	9.60	18.68	46.00	-27.32	AVG
11	17.6034	7.34	9.74	17.08	60.00	-42.92	QP
12	17.6034	1.98	9.74	11.72	50.00	-38.28	AVG

Note: 1. Result = Reading + Correct Factor.

2. If QP Result complies with AV limit, AV Result is deemed to comply with AV limit.

3. Test setup: RBW: 200 Hz (9 kHz ~ 150 kHz), 9 kHz (150 kHz ~ 30 MHz).

4. Step size: 80 Hz (0.009 MHz ~ 0.15 MHz), 4 kHz (0.15 MHz ~ 30 MHz), Scan time: auto.

Note: All the modes and channels had been tested, but only the worst data was recorded in the report.

10. FREQUENCY STABILITY

LIMITS

The frequency of the carrier signal shall be maintained within band of operation.

TEST PROCEDURE

1. The EUT was placed inside an environmental chamber as the temperature in the chamber was varied between 0 °C ~ 40 °C (declared by customer).
2. The temperature was incremented by 10 °C intervals and the unit allowed to stabilize at each temperature before each measurement. The center frequency of the transmitting channel was evaluated at each temperature and the frequency deviation from the channel's center frequency was recorded.
3. The primary supply voltage is varied from 85 % to 115 % of the nominal value for non hand-carried battery and AC powered equipment. For hand-carried, battery-powered equipment, primary supply voltage is reduced to the battery operating end point which shall be specified by the manufacturer.

Connect the EUT to the spectrum analyser and use the following settings:

Center Frequency	The center frequency of the channel under test
Detector	Peak
RBW	10 kHz
VBW	$\geq 3 \times \text{RBW}$
Span	Encompass the entire emissions bandwidth (EBW) of the signal
Trace	Max hold
Sweep time	Auto

4. While maintaining a constant temperature inside the environmental chamber, turn the EUT on and record the operating frequency at startup, and at 2 minutes, 5minutes, and 10 minutes after the EUT is energized.
5. Allow the trace to stabilize, find the peak value of the power envelope and record the frequency, then calculated the frequency drift.

TEST SETUP

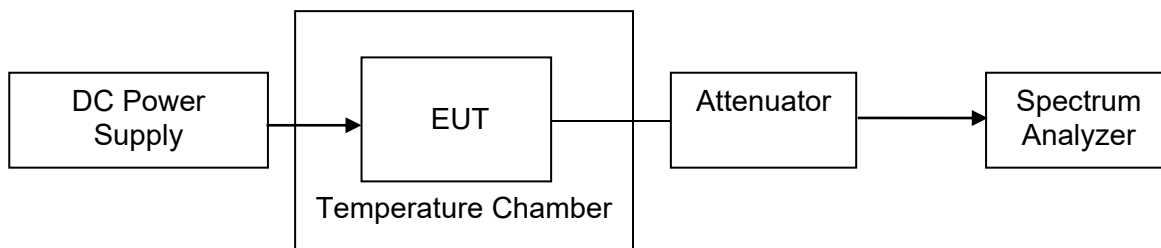



TEST ENVIRONMENT

	Normal Test Conditions	Extreme Test Conditions
Relative Humidity	20 % - 75 %	/
Atmospheric Pressure	100 kPa ~102 kPa	/
Temperature	T _N (Normal Temperature): 22 °C – 28 °C	T _L (Low Temperature): -10 °C
		T _H (High Temperature): 40 °C
Supply Voltage	V _N (Normal Voltage): DC 6.8 V	V _L (Low Voltage): DC 5.78 V
		V _H (High Voltage): DC 7.82 V

RESULTS

Please refer to Appendix E.



11. ANTENNA REQUIREMENTS

APPLICABLE REQUIREMENTS

Please refer to FCC §15.203

An intentional radiator shall be designed to ensure that no antenna other than that furnished by the responsible party shall be used with the device. The use of a permanently attached antenna or of an antenna that uses a unique coupling to the intentional radiator shall be considered sufficient to comply with the provisions of this section. The manufacturer may design the unit so that a broken antenna can be replaced by the user, but the use of a standard antenna jack or electrical connector is prohibited.

Please refer to FCC §15.407(a)(1)(2)(3)

If transmitting antennas of directional gain greater than 6 dBi are used, both the maximum conducted output power and the maximum power spectral density shall be reduced by the amount in dB that the directional gain of the antenna exceeds 6 dBi..

RESULTS

Complies



11.1. Appendix A1: Occupied channel bandwidth

11.1.1. Test Result

Test Mode	Antenna	Channel	OCB [MHz]	FL[MHz]	FH[MHz]	Verdict
20M	Ant0	5735.5	17.845	5726.621	5744.466	PASS
	Ant1	5735.5	17.973	5726.543	5744.516	PASS
	Ant0	5786.5	17.947	5777.579	5795.526	PASS
	Ant1	5786.5	17.821	5777.616	5795.437	PASS
	Ant0	5839.5	17.842	5830.650	5848.492	PASS
	Ant1	5839.5	17.794	5830.638	5848.432	PASS
40M	Ant0	5745.5	35.589	5727.794	5763.383	PASS
	Ant1	5745.5	35.581	5727.773	5763.354	PASS
	Ant0	5786.5	35.723	5768.576	5804.299	PASS
	Ant1	5786.5	35.713	5768.672	5804.385	PASS
	Ant0	5829.5	35.635	5811.659	5847.294	PASS
	Ant1	5829.5	35.630	5811.625	5847.255	PASS
10M	Ant0	5730.5	9.1512	5725.901	5735.052	PASS
	Ant1	5730.5	9.1511	5725.933	5735.084	PASS
	Ant0	5786.5	9.1414	5781.928	5791.069	PASS
	Ant1	5786.5	9.1457	5781.949	5791.095	PASS
	Ant0	5844.5	9.1419	5839.910	5849.051	PASS
	Ant1	5844.5	9.1374	5839.947	5849.085	PASS
1.4M	Ant0	5726.5	1.1251	5725.936	5727.061	PASS
	Ant0	5786.5	1.1244	5785.936	5787.060	PASS
	Ant0	5846.5	1.1239	5845.938	5847.062	PASS
1.4M CA	Ant0	5728.12	1.1223	5727.559	5728.681	PASS
	Ant0	5788.12	1.1211	5787.563	5788.685	PASS
	Ant0	5848.12	1.1213	5847.559	5848.681	PASS
3M	Ant0	5727.5	2.2035	5726.399	5728.603	PASS
	Ant0	5787.5	2.2020	5786.399	5788.601	PASS
	Ant0	5844.5	2.2111	5843.391	5845.603	PASS
3M CA	Ant0	5730.2	2.2081	5729.094	5731.302	PASS
	Ant0	5790.2	2.2008	5789.105	5791.305	PASS
	Ant0	5847.2	2.1979	5846.105	5848.312	PASS



11.1.2. Test Graphs



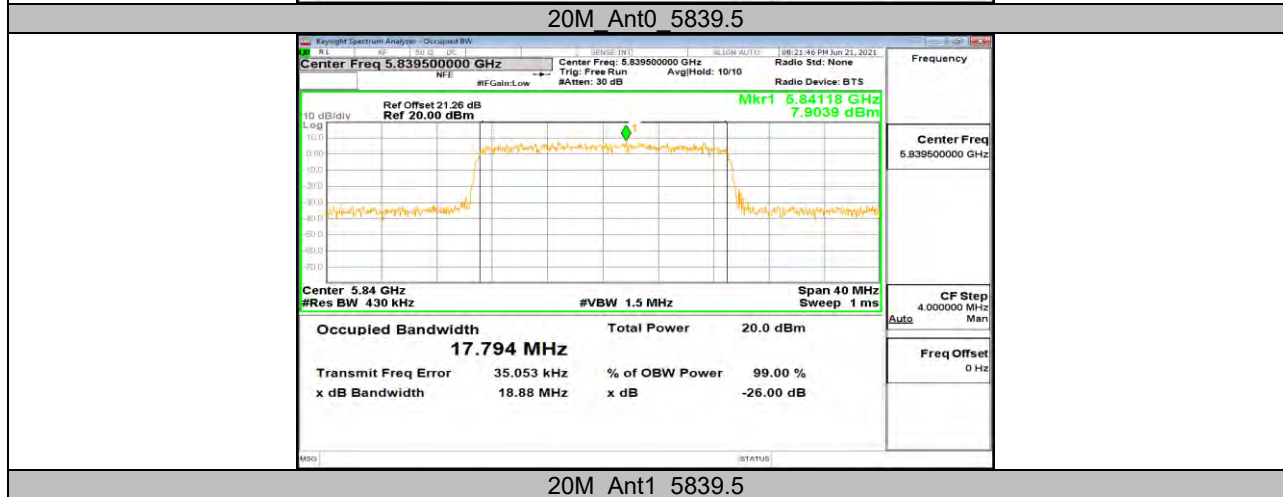
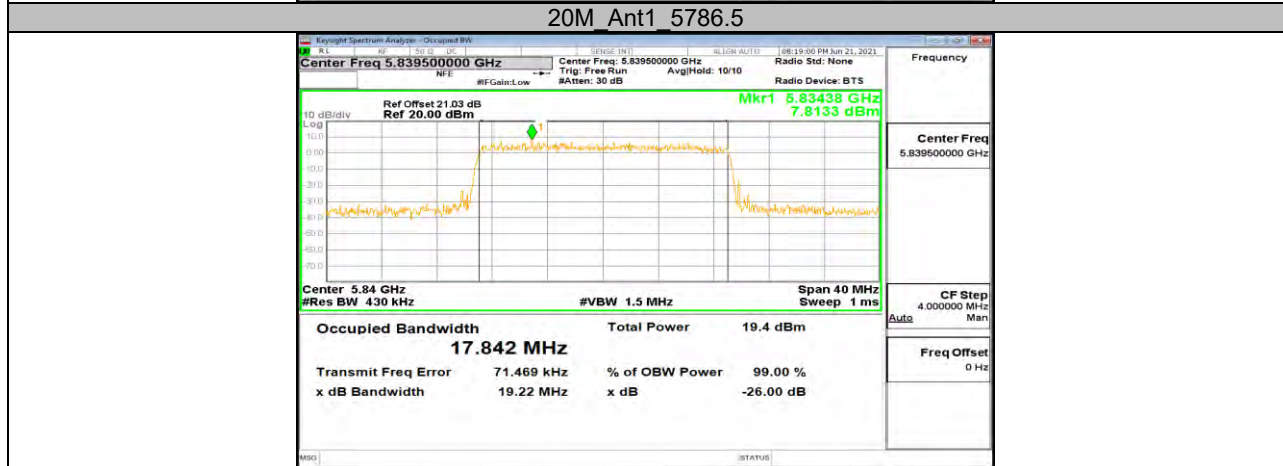
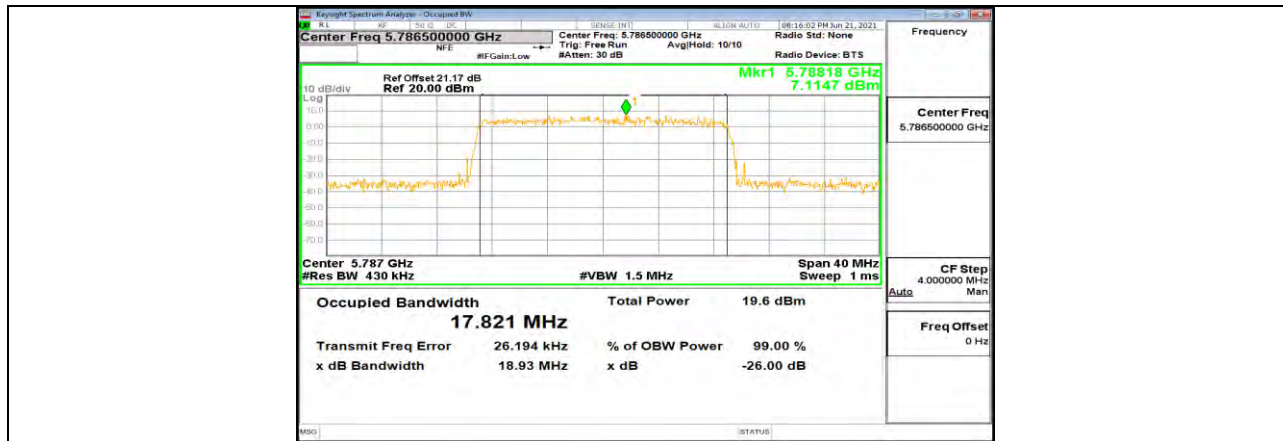

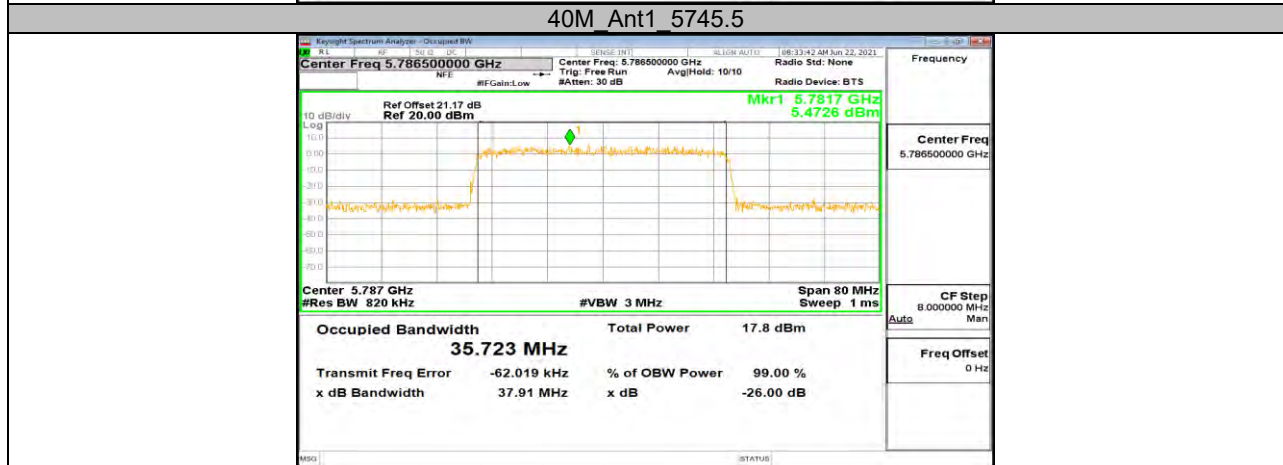
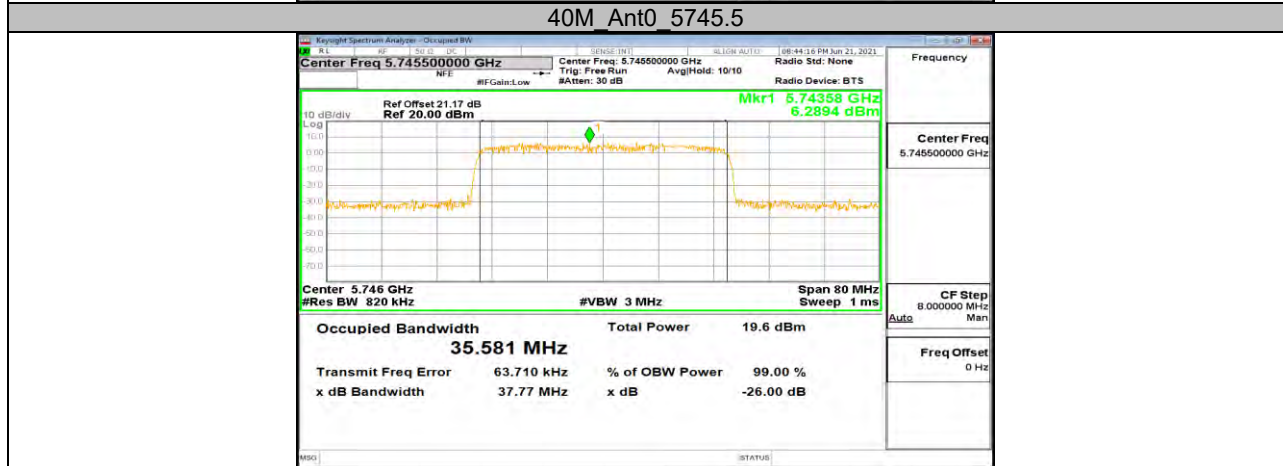
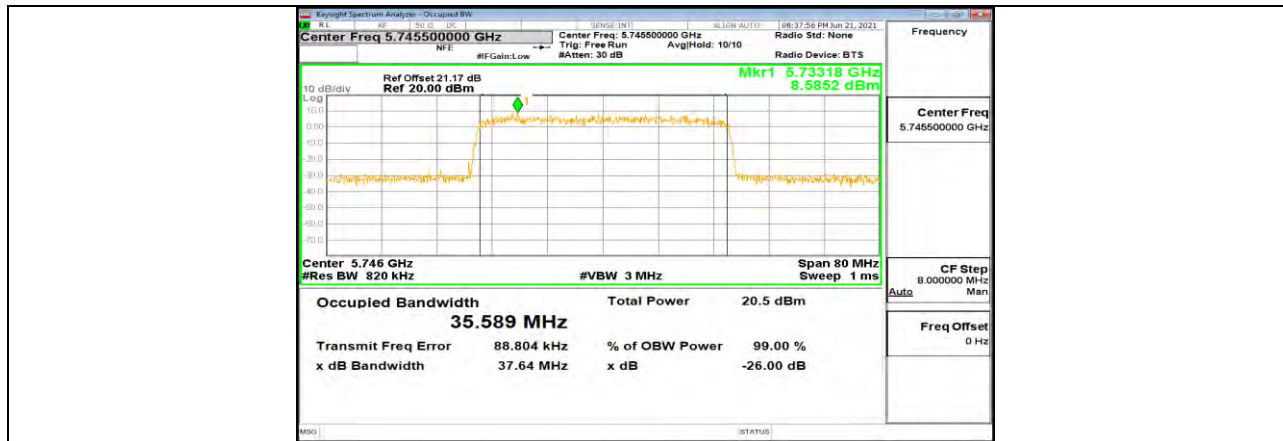

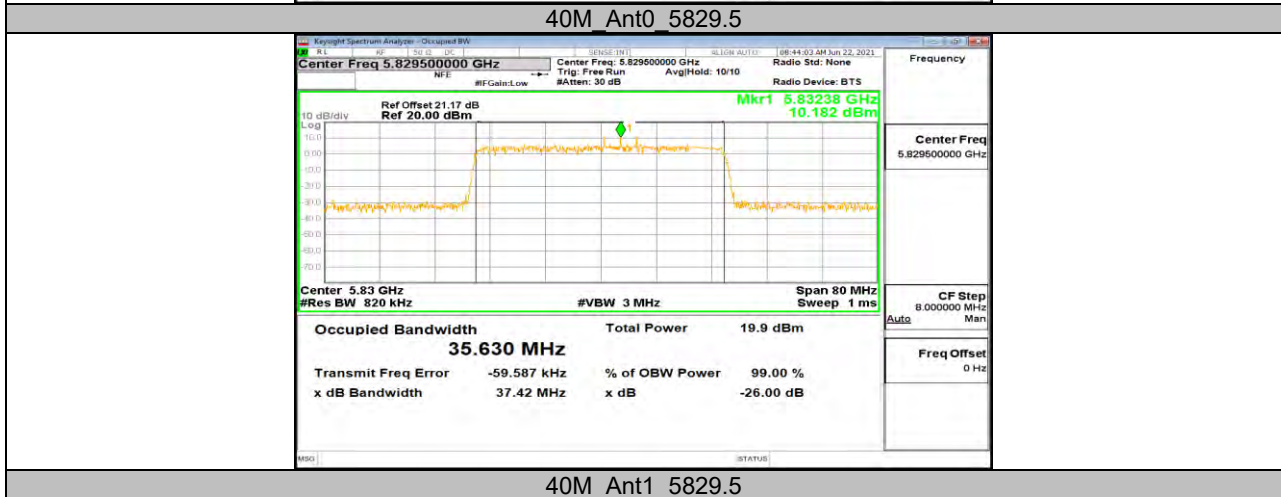
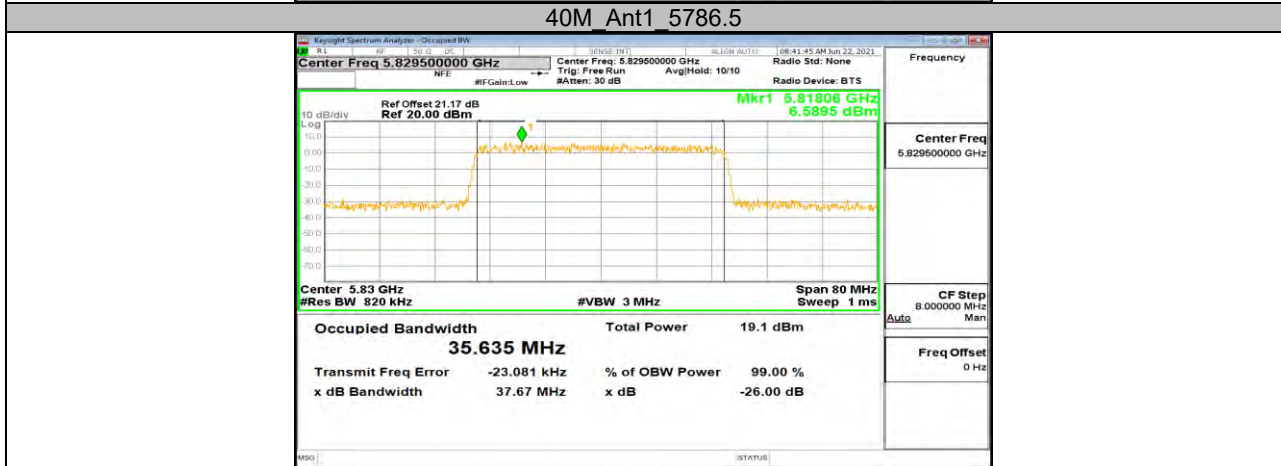
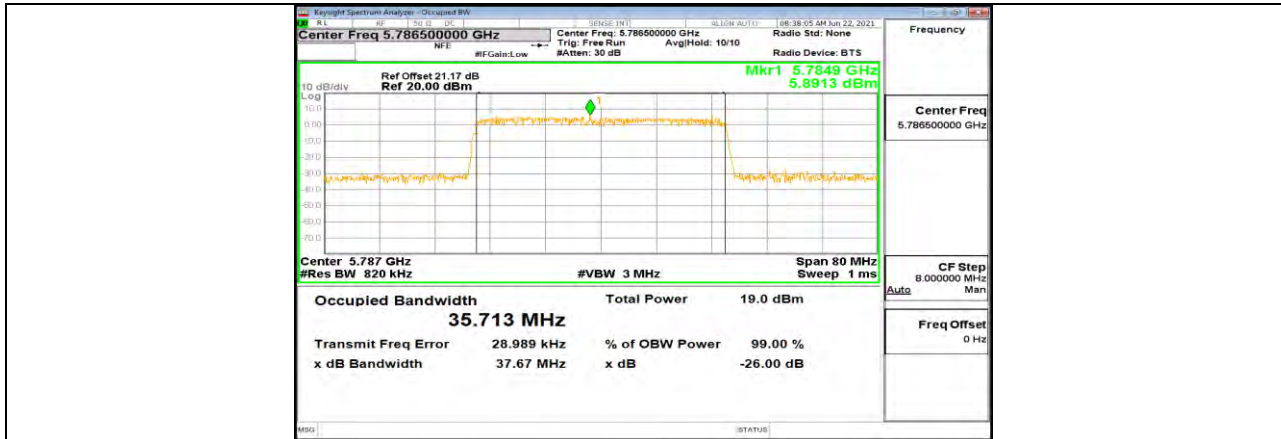

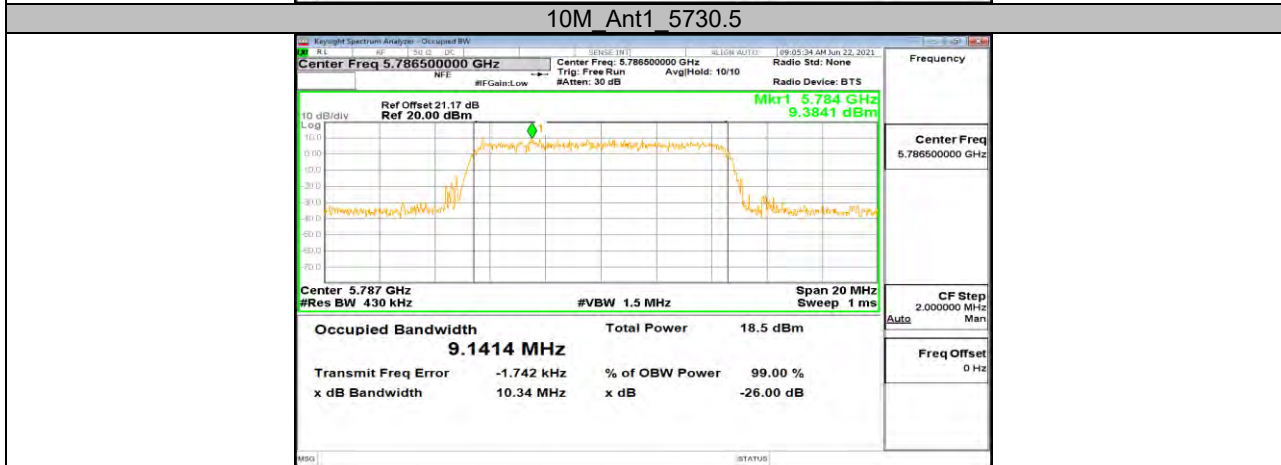
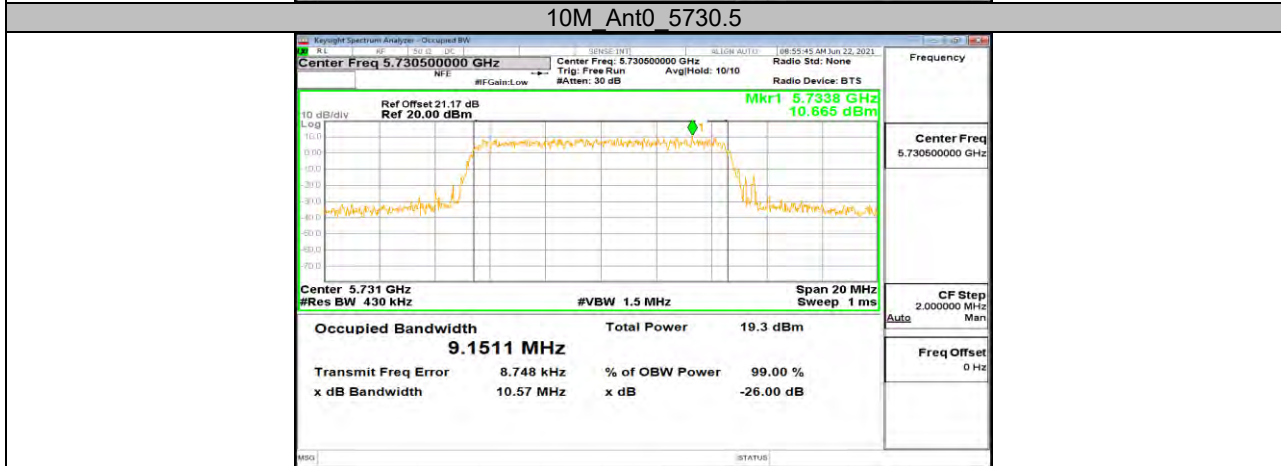
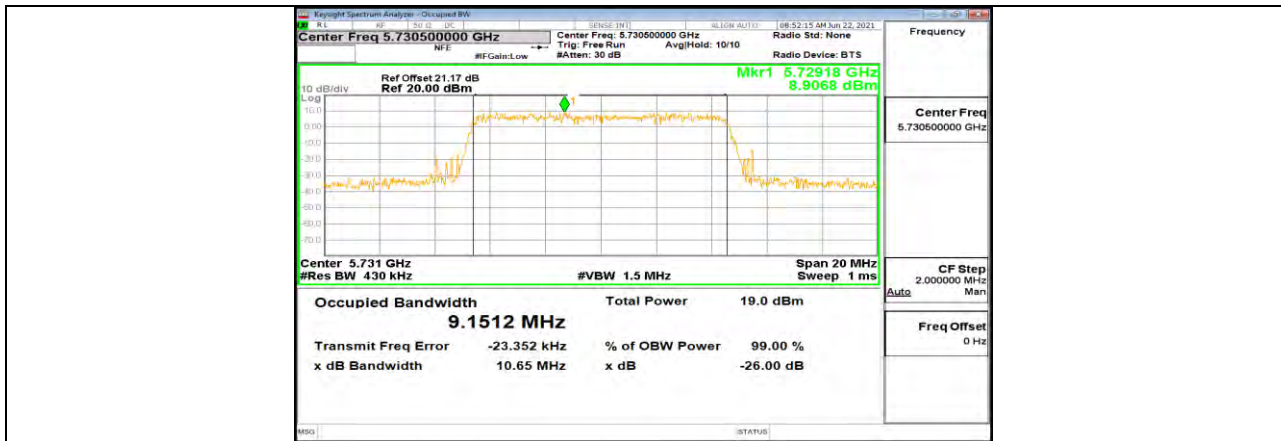

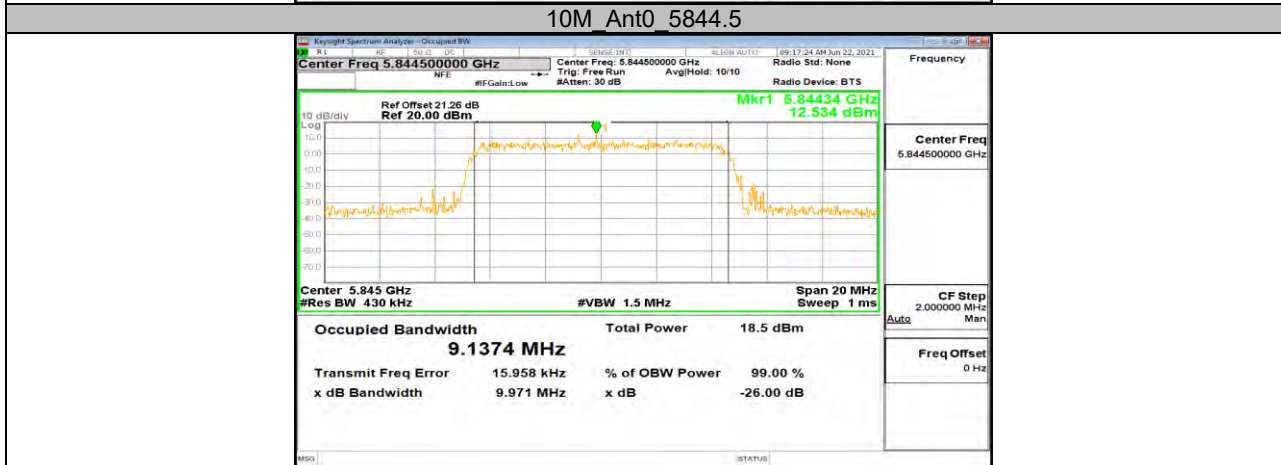
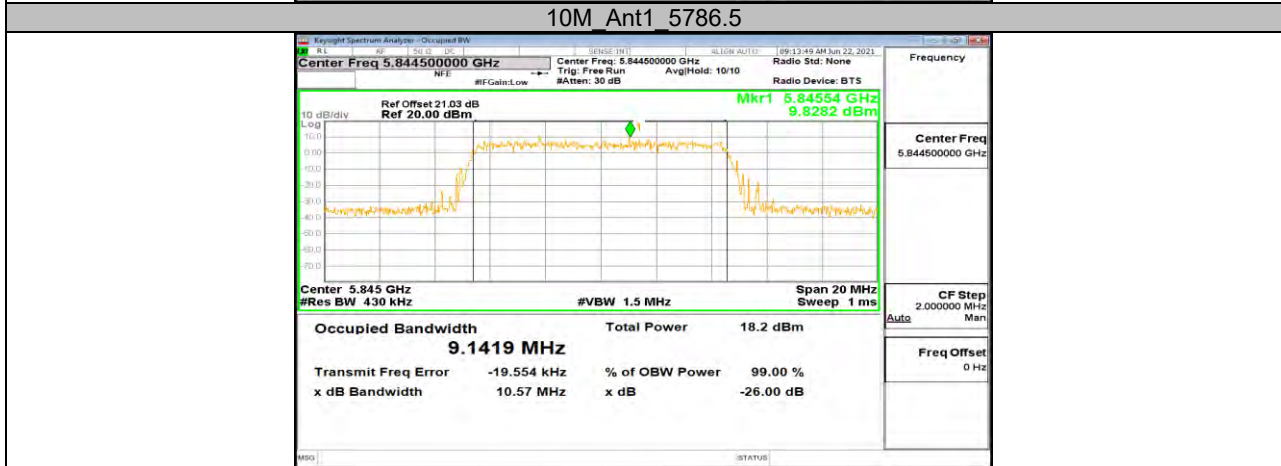
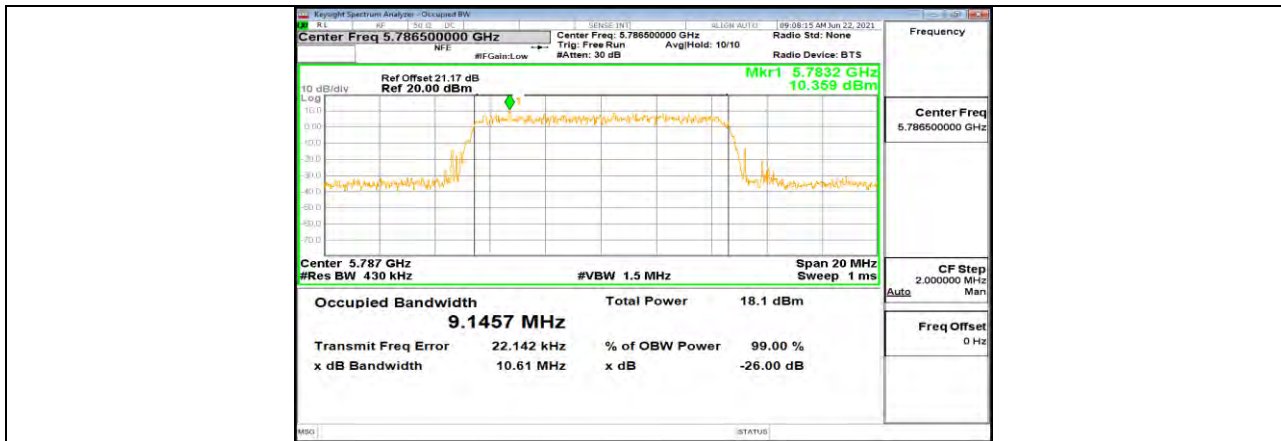









**11.2. Appendix A2: Min emission bandwidth****11.2.1. Test Result**

Test Mode	Antenna	Channel	6db EBW [MHz]	FL[MHz]	FH[MHz]	Limit[MHz]	Verdict
20M	Ant0	5735.5	18.000	5726.540	5744.540	0.5	PASS
	Ant1	5735.5	17.960	5726.540	5744.500	0.5	PASS
	Ant0	5786.5	18.040	5777.500	5795.540	0.5	PASS
	Ant1	5786.5	17.960	5777.540	5795.500	0.5	PASS
	Ant0	5839.5	17.960	5830.500	5848.460	0.5	PASS
	Ant1	5839.5	17.800	5830.660	5848.460	0.5	PASS
40M	Ant0	5745.5	36.080	5727.500	5763.580	0.5	PASS
	Ant1	5745.5	35.280	5727.900	5763.180	0.5	PASS
	Ant0	5786.5	35.920	5768.420	5804.340	0.5	PASS
	Ant1	5786.5	36.000	5768.500	5804.500	0.5	PASS
	Ant0	5829.5	36.080	5811.420	5847.500	0.5	PASS
	Ant1	5829.5	36.080	5811.420	5847.500	0.5	PASS
10M	Ant0	5730.5	9.040	5725.980	5735.020	0.5	PASS
	Ant1	5730.5	9.040	5725.980	5735.020	0.5	PASS
	Ant0	5786.5	9.020	5782.000	5791.020	0.5	PASS
	Ant1	5786.5	9.000	5782.000	5791.000	0.5	PASS
	Ant0	5844.5	8.980	5839.980	5848.960	0.5	PASS
	Ant1	5844.5	8.940	5839.980	5848.920	0.5	PASS
1.4M	Ant0	5726.5	1.079	5725.964	5727.043	0.5	PASS
	Ant0	5786.5	1.076	5785.961	5787.037	0.5	PASS
	Ant0	5846.5	1.092	5845.956	5847.048	0.5	PASS
1.4M CA	Ant0	5728.12	1.095	5727.571	5728.666	0.5	PASS
	Ant0	5788.12	1.078	5787.581	5788.659	0.5	PASS
	Ant0	5848.12	1.080	5847.585	5848.665	0.5	PASS
3M CA	Ant0	5727.5	2.175	5726.413	5728.588	0.5	PASS
	Ant0	5787.5	2.184	5786.409	5788.593	0.5	PASS
	Ant0	5844.5	2.182	5843.409	5845.591	0.5	PASS
1.4M CA	Ant0	5730.2	2.191	5729.102	5731.293	0.5	PASS
	Ant0	5790.2	2.171	5789.117	5791.288	0.5	PASS
	Ant0	5847.2	2.173	5846.116	5848.289	0.5	PASS



11.2.2. Test Graphs





20M Ant1 5786.5



20M Ant0 5839.5



20M Ant1 5839.5



40M Ant0 5745.5



40M Ant1 5745.5

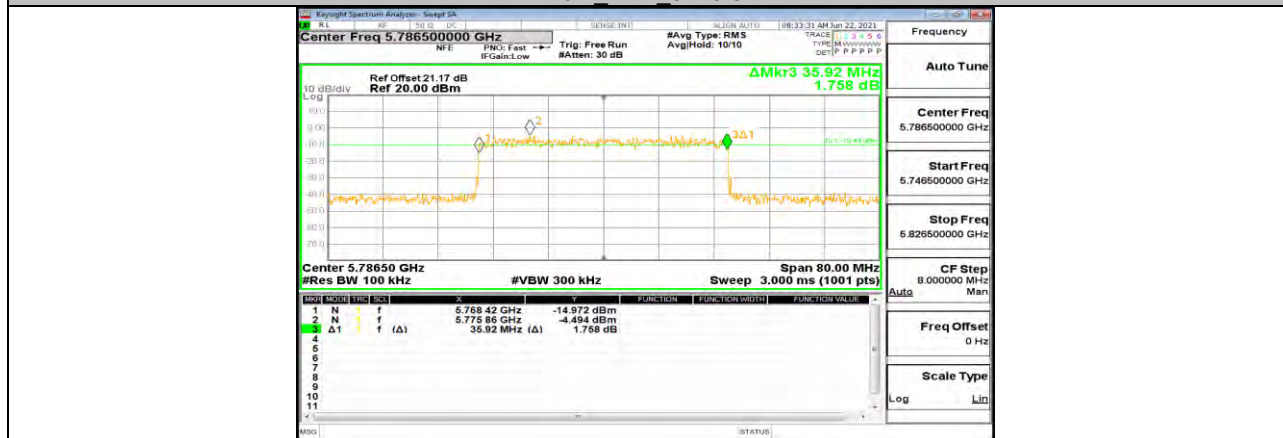

40M Ant0 5786.5

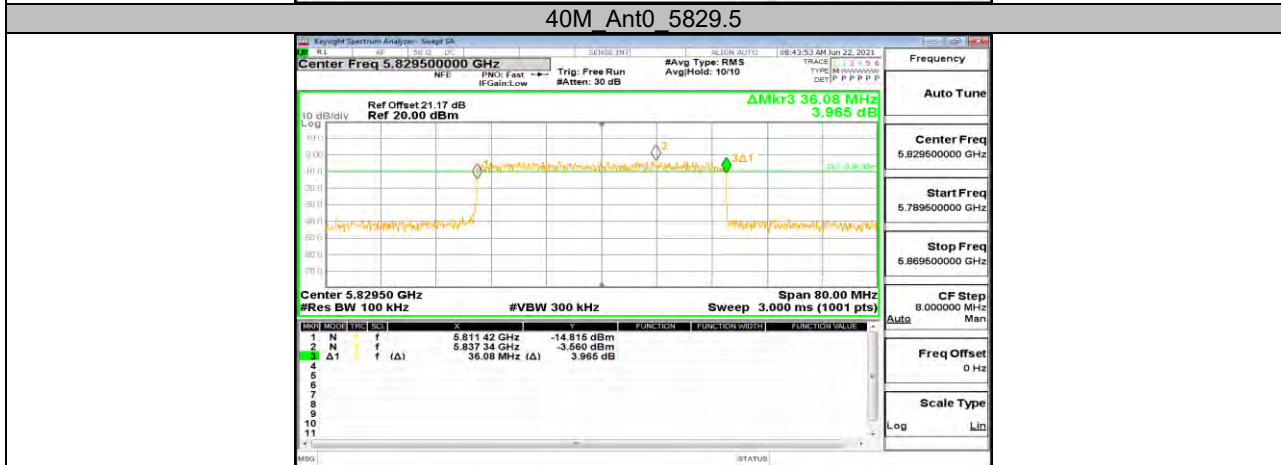



10M Ant0 5730.5



10M Ant1 5730.5



10M Ant0 5786.5



10M Ant1 5786.5



10M Ant0 5844.5

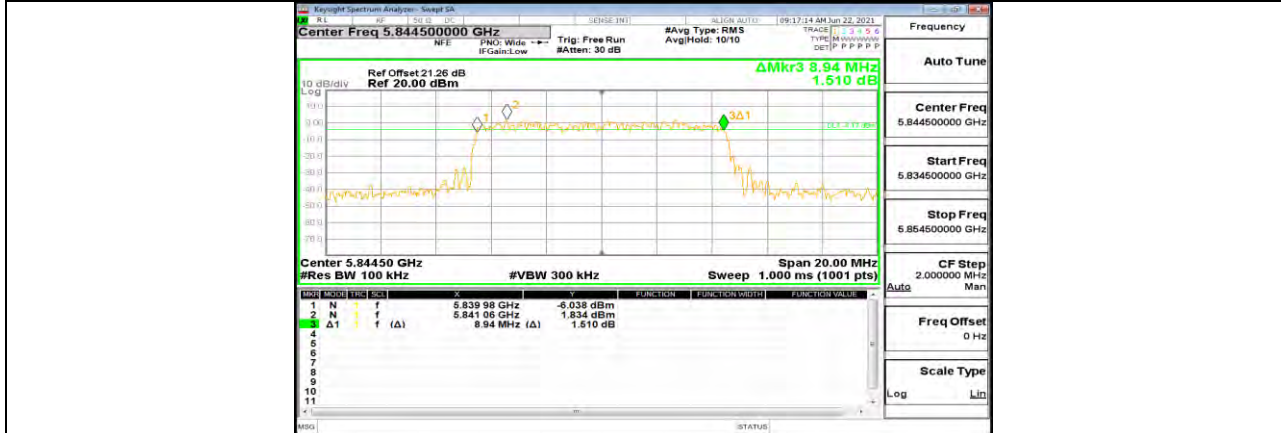

10M Ant1 5844.5

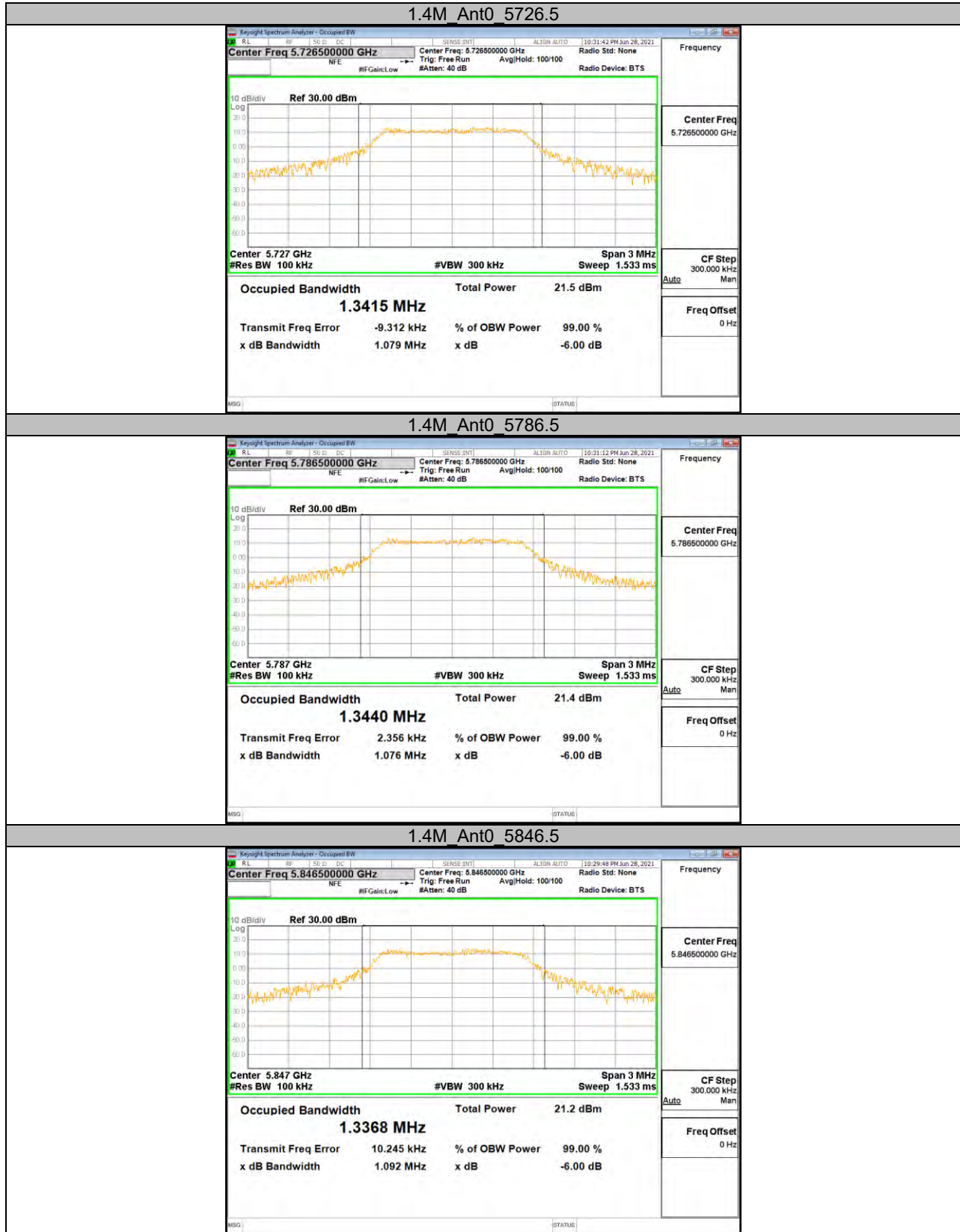

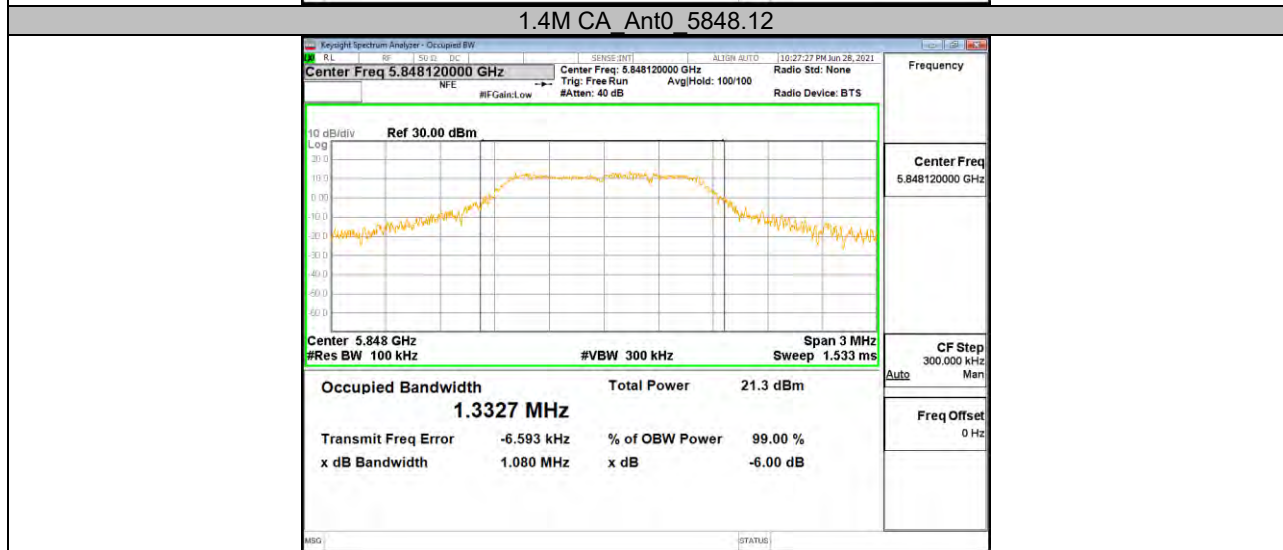
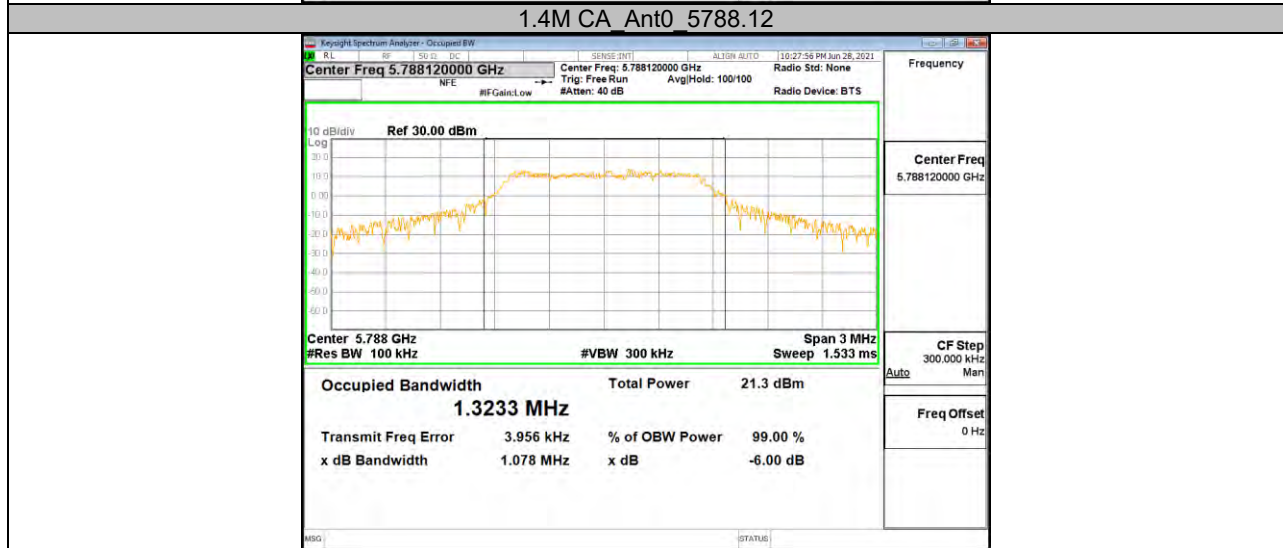
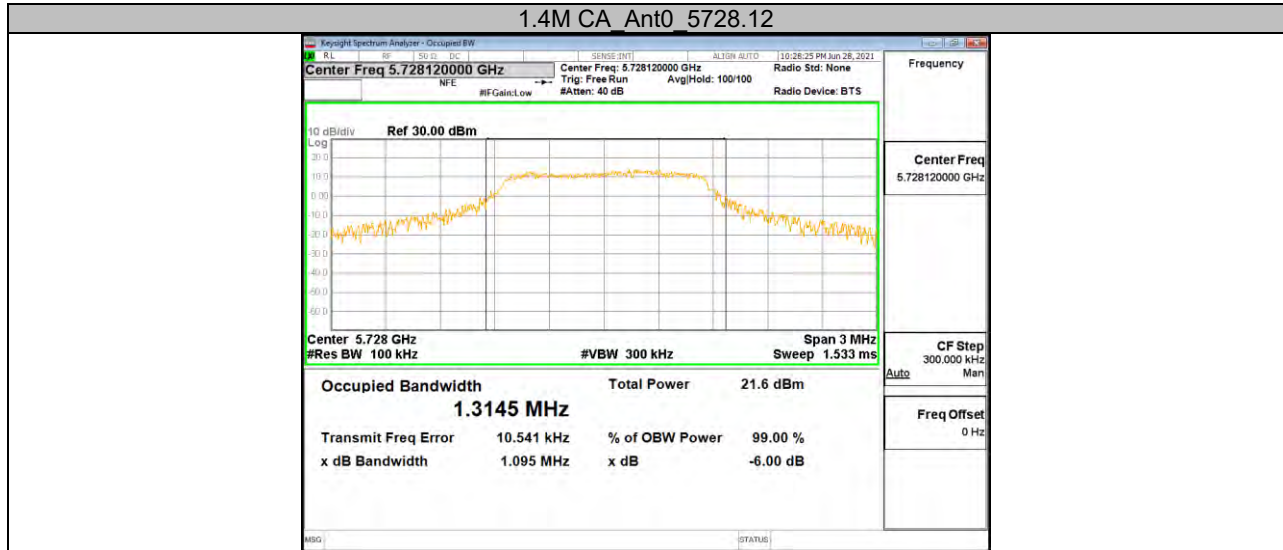



3M Ant0 5727.5

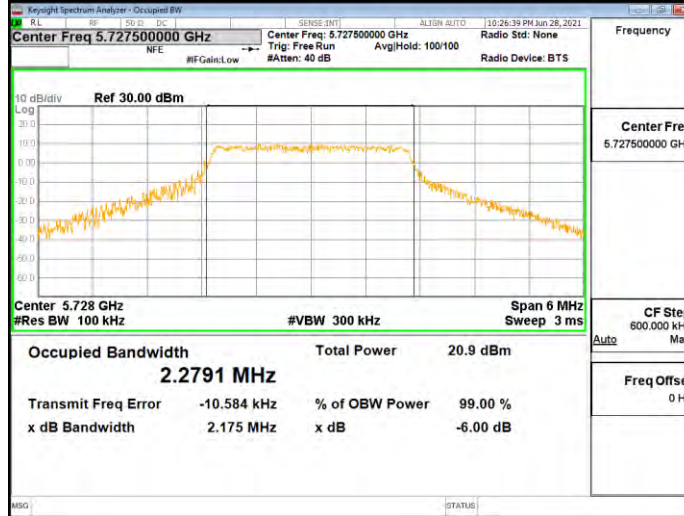

3M Ant0 5787.5

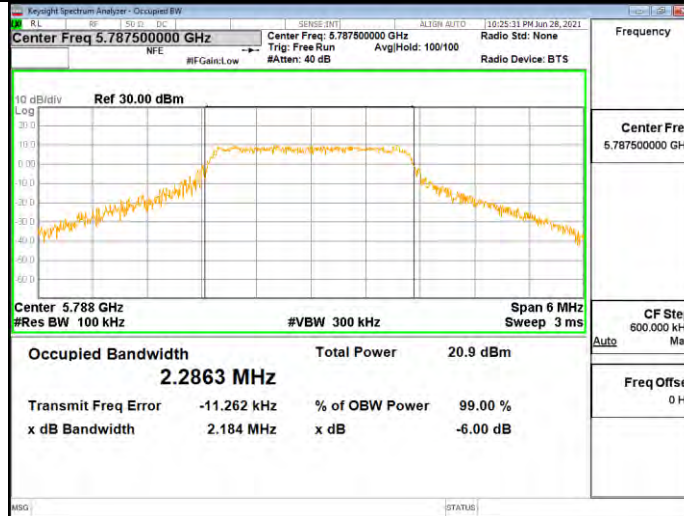

3M Ant0 5844.5

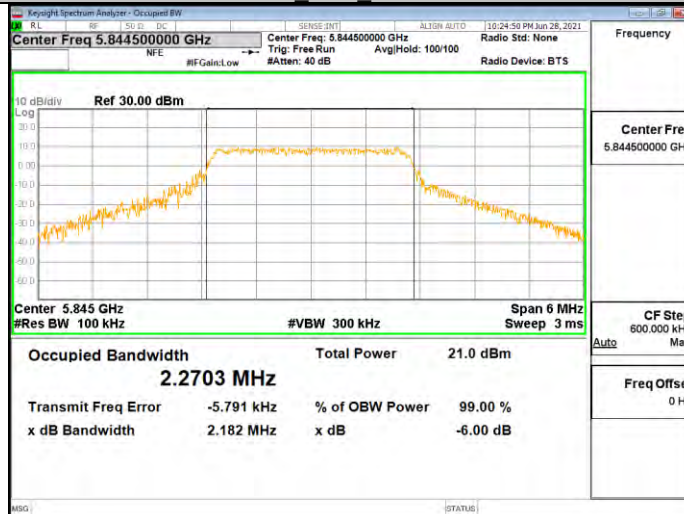



3M CA Ant0 5730.2

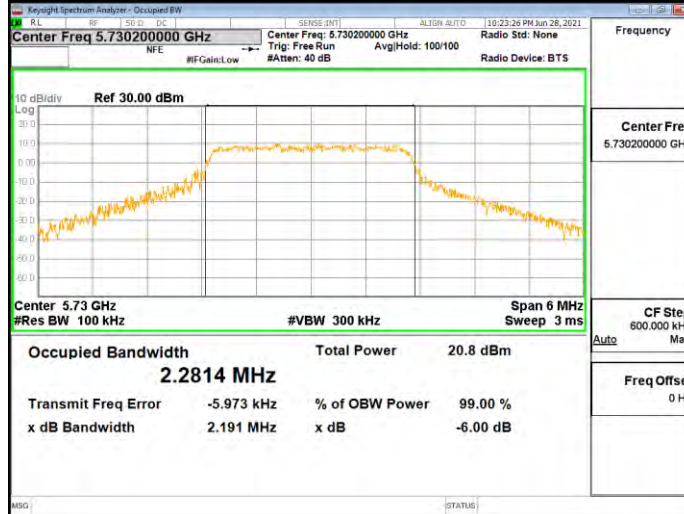

3M CA Ant0 5790.2

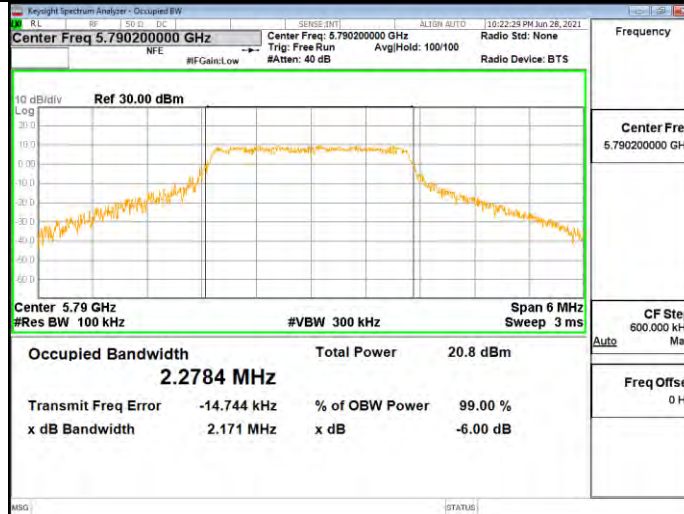

3M CA Ant0 5847.2

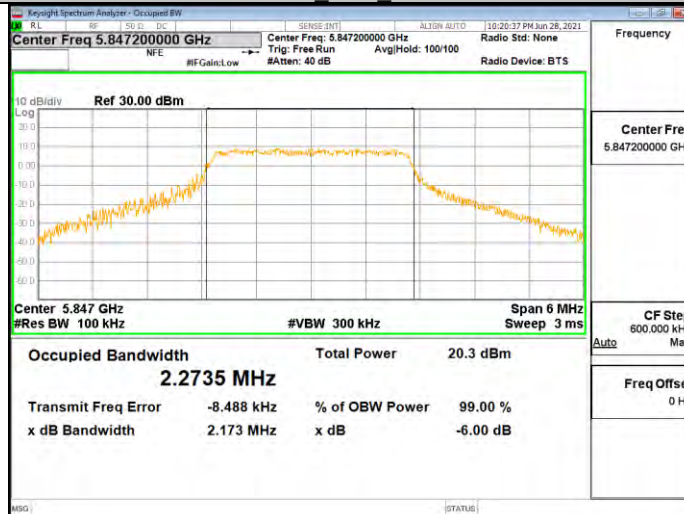

**11.3. Appendix B: Maximum conducted output power****11.3.1. Test Result**

Test Mode	Antenna	Channel	Result[dBm]	Limit[dBm]	Verdict
10M	Ant0	Low	12.44	<=30	PASS
	Ant1	Low	12.82	<=30	PASS
	Ant2	Low	13.56	<=30	PASS
	Ant3	Low	12.88	<=30	PASS
	total Ant0&1	Low	15.64	<=29.99	PASS
	total Ant0&3	Low	15.68	<=29.99	PASS
	total Ant2&1	Low	16.22	<=29.99	PASS
	total Ant2&3	Low	16.24	<=29.99	PASS
	Ant0	MID	12.97	<=30	PASS
	Ant1	MID	12.67	<=30	PASS
	Ant2	MID	13.91	<=30	PASS
	Ant3	MID	13.21	<=30	PASS
	total Ant0&1	MID	15.83	<=29.99	PASS
	total Ant0&3	MID	16.10	<=29.99	PASS
	total Ant2&1	MID	16.34	<=29.99	PASS
	total Ant2&3	MID	16.58	<=29.99	PASS
	Ant0	High	12.61	<=30	PASS
	Ant1	High	12.98	<=30	PASS
	Ant2	High	13.51	<=30	PASS
	Ant3	High	13.17	<=30	PASS
total Ant0&1	High	15.81	<=29.99	PASS	
total Ant0&3	High	15.91	<=29.99	PASS	
total Ant2&1	High	16.26	<=29.99	PASS	
total Ant2&3	High	16.35	<=29.99	PASS	
20M	Ant0	Low	13.85	<=30	PASS
	Ant1	Low	13.37	<=30	PASS
	Ant2	Low	13.33	<=30	PASS
	Ant3	Low	12.64	<=30	PASS
	total Ant0&1	Low	16.63	<=29.99	PASS
	total Ant0&3	Low	16.30	<=29.99	PASS
	total Ant2&1	Low	16.36	<=29.99	PASS
	total Ant2&3	Low	16.01	<=29.99	PASS
	Ant0	MID	14.07	<=30	PASS
	Ant1	MID	13.91	<=30	PASS
	Ant2	MID	13.72	<=30	PASS
	Ant3	MID	12.96	<=30	PASS
	total Ant0&1	MID	17.00	<=29.99	PASS
	total Ant0&3	MID	16.56	<=29.99	PASS
	total Ant2&1	MID	16.83	<=29.99	PASS
	total Ant2&3	MID	16.37	<=29.99	PASS
	Ant0	High	14.00	<=30	PASS
	Ant1	High	14.18	<=30	PASS
	Ant2	High	13.40	<=30	PASS
	Ant3	High	13.01	<=30	PASS
total Ant0&1	High	17.10	<=29.99	PASS	
total Ant0&3	High	16.54	<=29.99	PASS	
total Ant2&1	High	16.82	<=29.99	PASS	
total Ant2&3	High	16.22	<=29.99	PASS	
40M	Ant0	Low	13.78	<=30	PASS
	Ant1	Low	13.20	<=30	PASS
	Ant2	Low	12.99	<=30	PASS
	Ant3	Low	12.75	<=30	PASS
	total Ant0&1	Low	16.51	<=29.99	PASS
total Ant0&3	Low	16.31	<=29.99	PASS	



	total Ant2&1	Low	16.11	<=29.99	PASS	
	total Ant2&3	Low	15.88	<=29.99	PASS	
	Ant0	MID	12.84	<=30	PASS	
	Ant1	MID	12.65	<=30	PASS	
	Ant2	MID	13.50	<=30	PASS	
	Ant3	MID	12.72	<=30	PASS	
	total Ant0&1	MID	15.76	<=29.99	PASS	
	total Ant0&3	MID	15.79	<=29.99	PASS	
	total Ant2&1	MID	16.11	<=29.99	PASS	
	total Ant2&3	MID	16.14	<=29.99	PASS	
	Ant0	High	13.25	<=30	PASS	
	Ant1	High	13.30	<=30	PASS	
	Ant2	High	13.34	<=30	PASS	
	Ant3	High	12.88	<=30	PASS	
	total Ant0&1	High	16.29	<=29.99	PASS	
	total Ant0&3	High	16.08	<=29.99	PASS	
	total Ant2&1	High	16.33	<=29.99	PASS	
	total Ant2&3	High	16.13	<=29.99	PASS	
1.4M	Ant0	Low	23.59	<=30	PASS	
	Ant1	Low	23.67	<=30	PASS	
	Ant2	Low	24.01	<=30	PASS	
	Ant3	Low	23.19	<=30	PASS	
	total Ant0&1	Low	26.64	<=29.99	PASS	
	total Ant0&3	Low	26.40	<=29.99	PASS	
	total Ant2&1	Low	26.85	<=29.99	PASS	
	total Ant2&3	Low	26.63	<=29.99	PASS	
	Ant0	MID	24.08	<=30	PASS	
	Ant1	MID	23.52	<=30	PASS	
	Ant2	MID	24.04	<=30	PASS	
	Ant3	MID	23.08	<=30	PASS	
	total Ant0&1	MID	26.82	<=29.99	PASS	
	total Ant0&3	MID	26.62	<=29.99	PASS	
	total Ant2&1	MID	26.80	<=29.99	PASS	
	total Ant2&3	MID	26.60	<=29.99	PASS	
	Ant0	High	23.63	<=30	PASS	
	Ant1	High	23.30	<=30	PASS	
	Ant2	High	23.98	<=30	PASS	
	Ant3	High	22.88	<=30	PASS	
	total Ant0&1	High	26.48	<=29.99	PASS	
	total Ant0&3	High	26.28	<=29.99	PASS	
	total Ant2&1	High	26.66	<=29.99	PASS	
	total Ant2&3	High	26.48	<=29.99	PASS	
	1.4M-CA	Ant0	Low	23.64	<=30	PASS
		Ant1	Low	23.68	<=30	PASS
		Ant2	Low	24.04	<=30	PASS
		Ant3	Low	22.88	<=30	PASS
total Ant0&1		Low	26.67	<=29.99	PASS	
total Ant0&3		Low	26.29	<=29.99	PASS	
total Ant2&1		Low	26.87	<=29.99	PASS	
total Ant2&3		Low	26.51	<=29.99	PASS	
Ant0		MID	24.12	<=30	PASS	
Ant1		MID	23.53	<=30	PASS	
Ant2		MID	23.98	<=30	PASS	
Ant3		MID	23.08	<=30	PASS	
total Ant0&1		MID	26.85	<=29.99	PASS	
total Ant0&3		MID	26.64	<=29.99	PASS	
total Ant2&1		MID	26.77	<=29.99	PASS	
total Ant2&3		MID	26.56	<=29.99	PASS	
Ant0		High	23.65	<=30	PASS	
Ant1		High	23.32	<=30	PASS	



	Ant2	High	23.96	<=30	PASS
	Ant3	High	22.85	<=30	PASS
	total Ant0&1	High	26.50	<=29.99	PASS
	total Ant0&3	High	26.28	<=29.99	PASS
	total Ant2&1	High	26.66	<=29.99	PASS
	total Ant2&3	High	26.45	<=29.99	PASS
3M	Ant0	Low	23.87	<=30	PASS
	Ant1	Low	23.66	<=30	PASS
	Ant2	Low	24.05	<=30	PASS
	Ant3	Low	23.05	<=30	PASS
	total Ant0&1	Low	26.78	<=29.99	PASS
	total Ant0&3	Low	26.49	<=29.99	PASS
	total Ant2&1	Low	26.87	<=29.99	PASS
	total Ant2&3	Low	26.59	<=29.99	PASS
	Ant0	MID	24.35	<=30	PASS
	Ant1	MID	23.51	<=30	PASS
	Ant2	MID	24.03	<=30	PASS
	Ant3	MID	22.95	<=30	PASS
	total Ant0&1	MID	26.96	<=29.99	PASS
	total Ant0&3	MID	26.72	<=29.99	PASS
	total Ant2&1	MID	26.79	<=29.99	PASS
	total Ant2&3	MID	26.53	<=29.99	PASS
	Ant0	High	23.69	<=30	PASS
	Ant1	High	23.33	<=30	PASS
	Ant2	High	23.65	<=30	PASS
	Ant3	High	22.78	<=30	PASS
	total Ant0&1	High	26.52	<=29.99	PASS
	total Ant0&3	High	26.27	<=29.99	PASS
	total Ant2&1	High	26.50	<=29.99	PASS
	total Ant2&3	High	26.25	<=29.99	PASS
3M-CA	Ant0	Low	23.80	<=30	PASS
	Ant1	Low	23.86	<=30	PASS
	Ant2	Low	24.15	<=30	PASS
	Ant3	Low	23.16	<=30	PASS
	total Ant0&1	Low	26.84	<=29.99	PASS
	total Ant0&3	Low	26.50	<=29.99	PASS
	total Ant2&1	Low	27.02	<=29.99	PASS
	total Ant2&3	Low	26.69	<=29.99	PASS
	Ant0	MID	24.20	<=30	PASS
	Ant1	MID	23.71	<=30	PASS
	Ant2	MID	24.24	<=30	PASS
	Ant3	MID	23.03	<=30	PASS
	total Ant0&1	MID	26.97	<=29.99	PASS
	total Ant0&3	MID	26.66	<=29.99	PASS
	total Ant2&1	MID	26.99	<=29.99	PASS
	total Ant2&3	MID	26.69	<=29.99	PASS
	Ant0	High	24.06	<=30	PASS
	Ant1	High	23.62	<=30	PASS
	Ant2	High	23.75	<=30	PASS
	Ant3	High	23.17	<=30	PASS
	total Ant0&1	High	26.86	<=29.99	PASS
	total Ant0&3	High	26.65	<=29.99	PASS
	total Ant2&1	High	26.70	<=29.99	PASS
	total Ant2&3	High	26.48	<=29.99	PASS

Note: 1. Conducted Power=Meas. Level+ Correction Factor

2. The Duty Cycle Factor (refer to section 7.1) had already compensated to the test data.

**11.4. Appendix C: Maximum power spectral density****11.4.1. Test Result**

Test Mode	Antenna	Channel	Result [dBm/MHz]	Limit[dBm/MHz]	Verdict
20M	Ant0	5735.5	-0.23	<=29.99	PASS
	Ant1	5735.5	-0.71	<=29.99	PASS
	total	5735.5	2.55	<=29.99	PASS
	Ant0	5786.5	-0.08	<=29.99	PASS
	Ant1	5786.5	-0.05	<=29.99	PASS
	total	5786.5	2.95	<=29.99	PASS
	Ant0	5839.5	-0.04	<=29.99	PASS
	Ant1	5839.5	0.17	<=29.99	PASS
	total	5839.5	3.08	<=29.99	PASS
40M	Ant0	5745.5	-3.37	<=29.99	PASS
	Ant1	5745.5	-3.68	<=29.99	PASS
	total	5745.5	-0.51	<=29.99	PASS
	Ant0	5786.5	-4.16	<=29.99	PASS
	Ant1	5786.5	-4.54	<=29.99	PASS
	total	5786.5	-1.34	<=29.99	PASS
	Ant0	5829.5	-1.56	<=29.99	PASS
	Ant1	5829.5	-3.63	<=29.99	PASS
	total	5829.5	0.54	<=29.99	PASS
10M	Ant0	5730.5	1.25	<=29.99	PASS
	Ant1	5730.5	2.03	<=29.99	PASS
	total	5730.5	4.67	<=29.99	PASS
	Ant0	5786.5	1.95	<=29.99	PASS
	Ant1	5786.5	1.78	<=29.99	PASS
	total	5786.5	4.88	<=29.99	PASS
	Ant0	5844.5	1.33	<=29.99	PASS
	Ant1	5844.5	1.91	<=29.99	PASS
	total	5844.5	4.64	<=29.99	PASS
1.4M	Ant0	5726.5	19.16	<=29.99	PASS
	Ant1	5726.5	20.94	<=29.99	PASS
	total	5726.5	23.15	<=29.99	PASS
	Ant0	5786.5	20.76	<=29.99	PASS
	Ant1	5786.5	21.90	<=29.99	PASS
	total	5786.5	24.38	<=29.99	PASS
	Ant0	5846.5	21.82	<=29.99	PASS
	Ant1	5846.5	21.90	<=29.99	PASS
	total	5786.5	24.87	<=29.99	PASS
1.4.M CA	Ant0	5728.12	22.42	<=29.99	PASS
	Ant1	5728.12	22.88	<=29.99	PASS
	total	5728.12	25.67	<=29.99	PASS
	Ant0	5788.12	21.66	<=29.99	PASS
	Ant1	5788.12	22.44	<=29.99	PASS
	total	5788.12	25.08	<=29.99	PASS
	Ant0	5848.12	20.29	<=29.99	PASS
	Ant1	5848.12	20.90	<=29.99	PASS
	total	5848.12	23.62	<=29.99	PASS
3M	Ant0	5727.5	18.40	<=29.99	PASS
	Ant1	5727.5	19.69	<=29.99	PASS
	total	5727.5	22.10	<=29.99	PASS
	Ant0	5787.5	17.80	<=29.99	PASS
	Ant1	5787.5	18.30	<=29.99	PASS
	total	5787.5	21.07	<=29.99	PASS
	Ant0	5844.5	16.89	<=29.99	PASS
	Ant1	5844.5	18.98	<=29.99	PASS
	total	5844.5	21.07	<=29.99	PASS



3M CA	Ant0	5730.2	18.09	<=29.99	PASS
	Ant1	5730.2	18.61	<=29.99	PASS
	total	5730.2	21.37	<=29.99	PASS
	Ant0	5790.2	17.83	<=29.99	PASS
	Ant1	5790.2	18.92	<=29.99	PASS
	total	5790.2	21.42	<=29.99	PASS
	Ant0	5847.2	16.96	<=29.99	PASS
	Ant1	5847.2	17.94	<=29.99	PASS
	total	5847.2	20.49	<=29.99	PASS

Note : The Result and Limit Unit is dBm/500 kHz in the band 5.725–5.85 GHz.

Note: All the modes and antennas had been tested, but only the worst data was recorded in the report.



11.4.2. Test Graphs

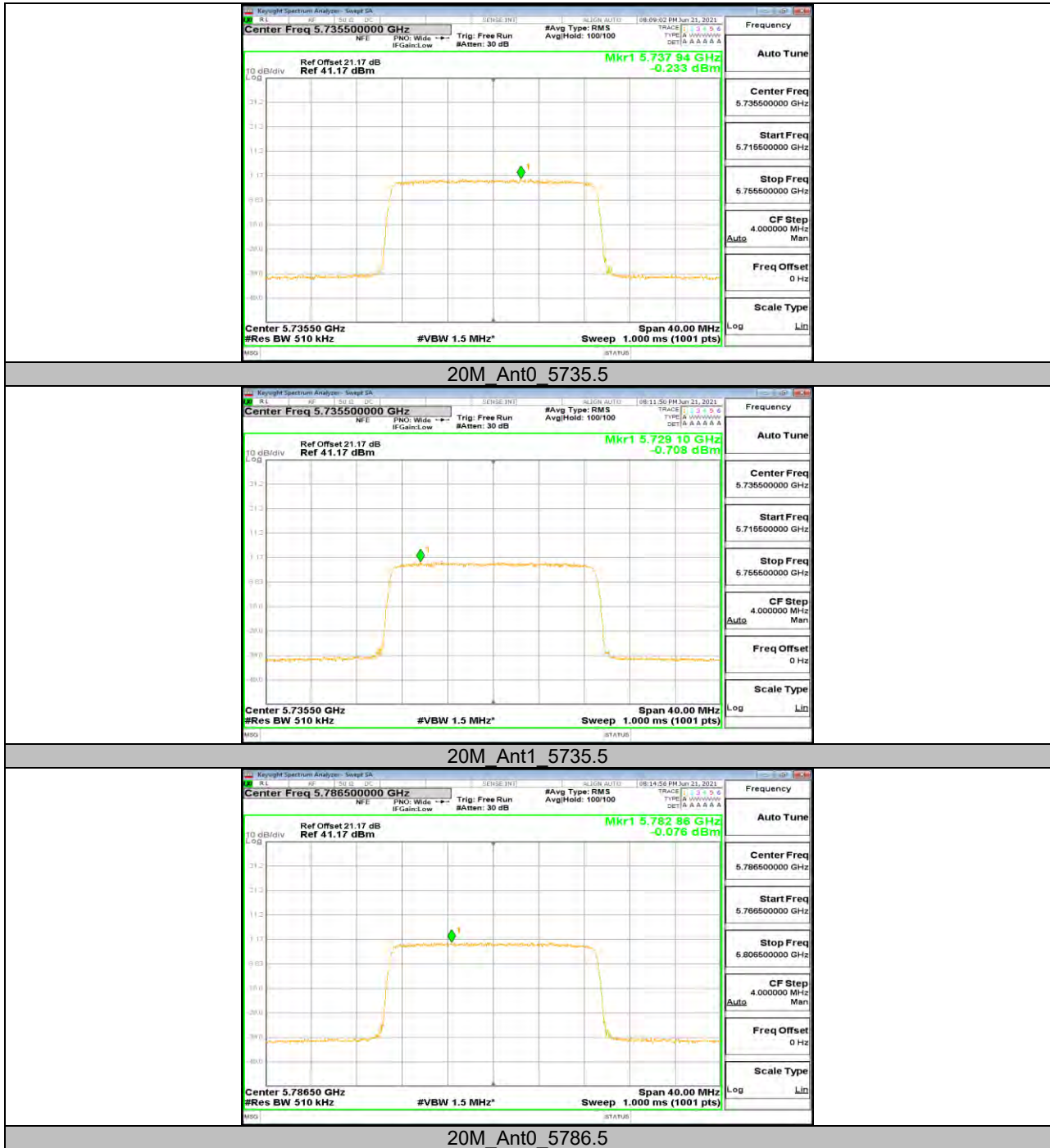

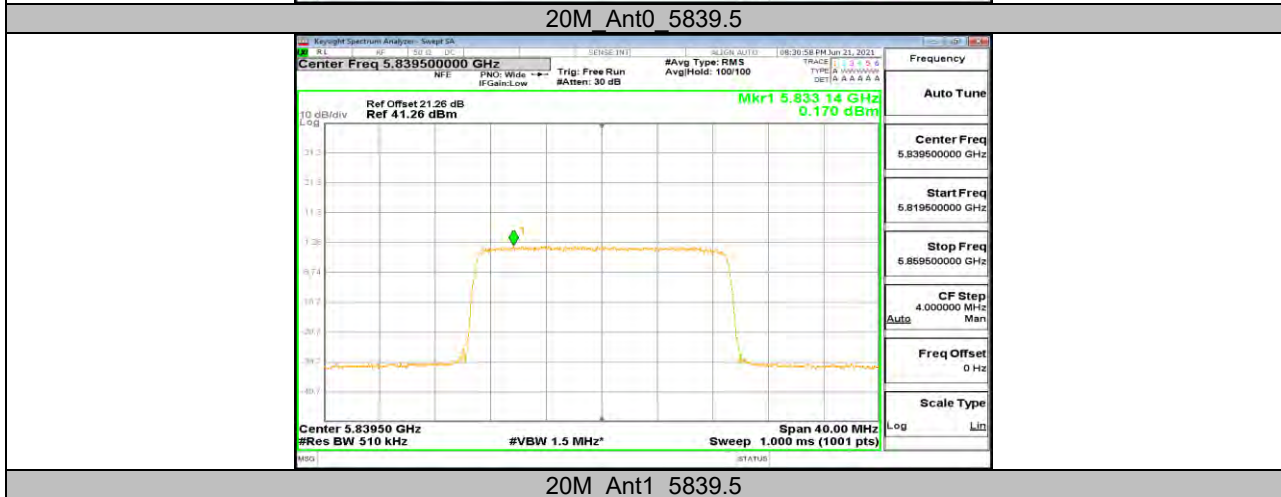
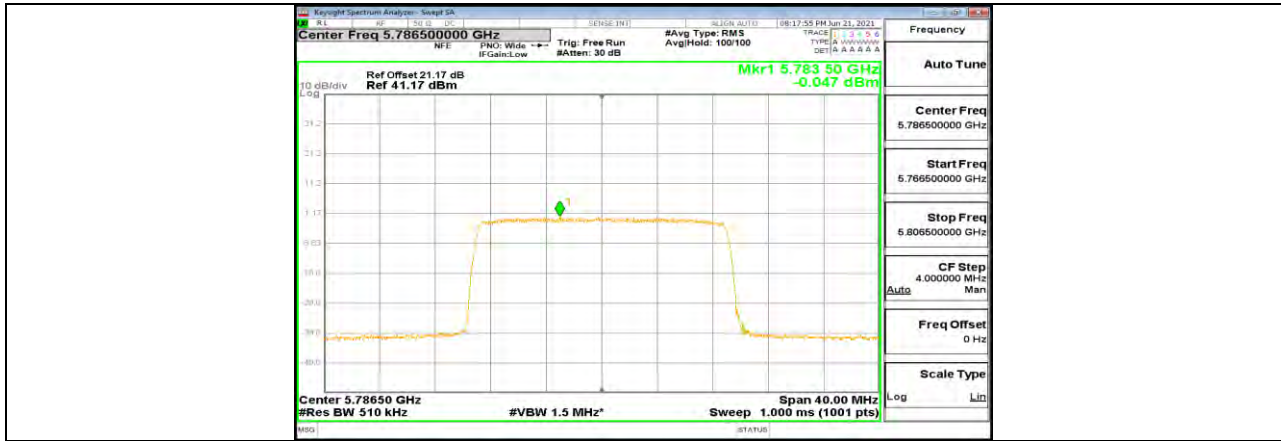

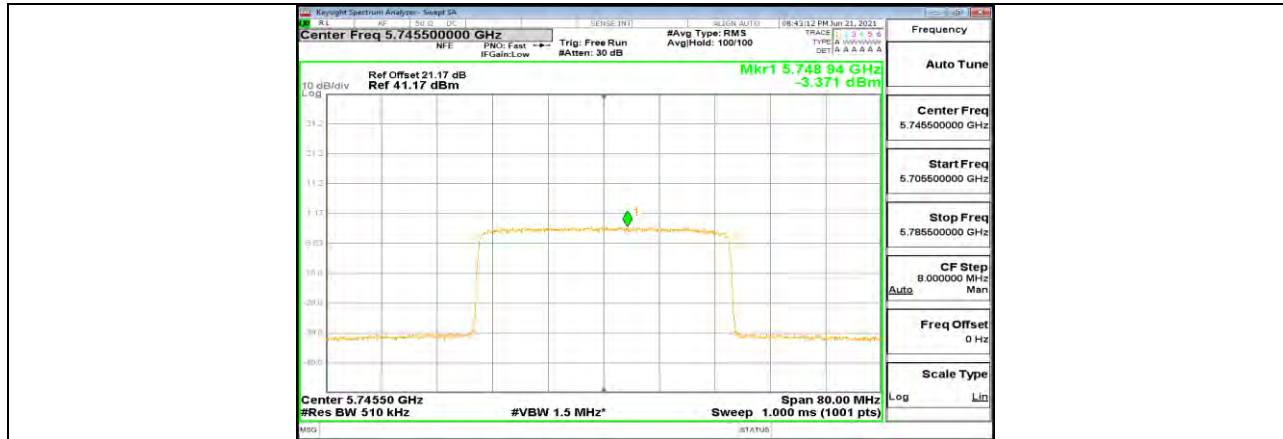

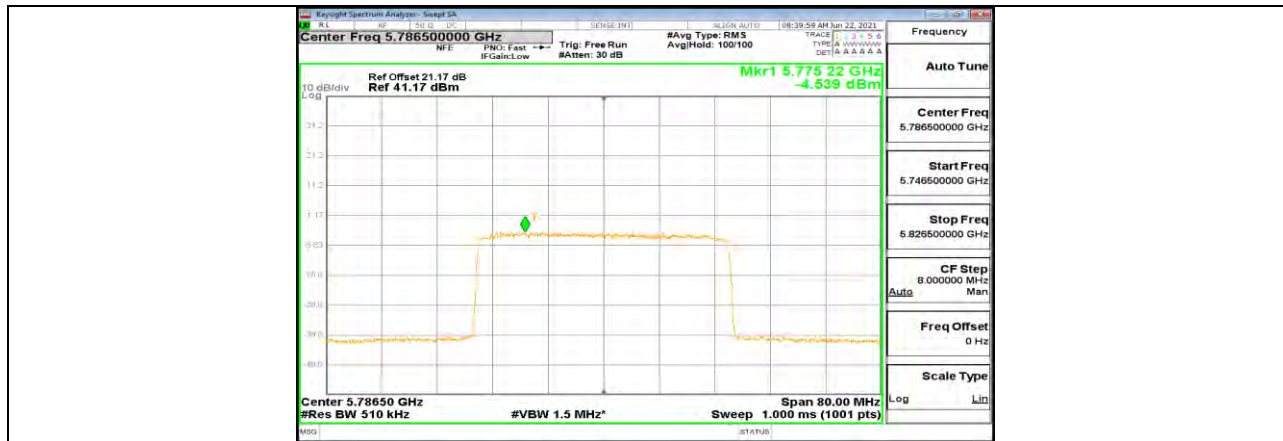

40M Ant1 5786.5



40M Ant0 5829.5

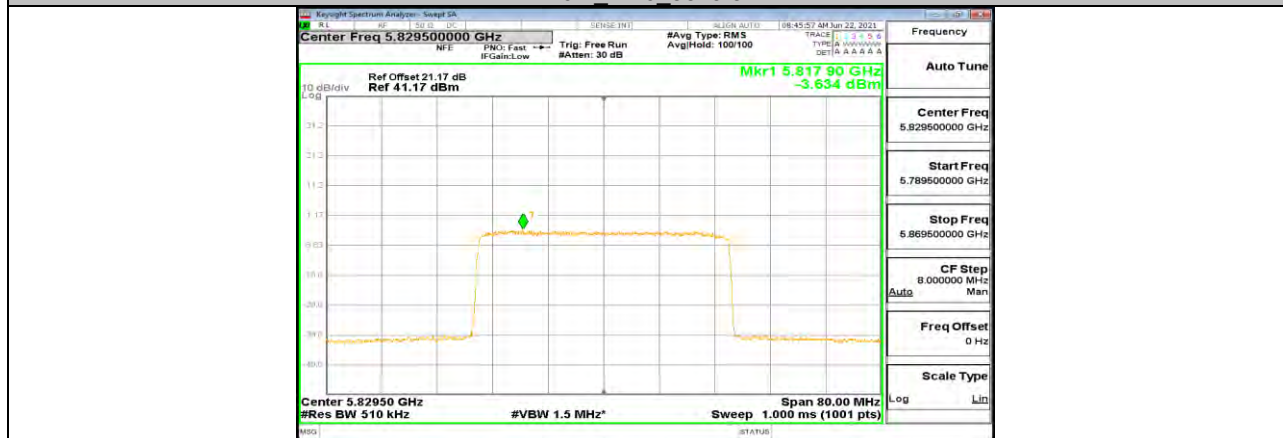

40M Ant1 5829.5

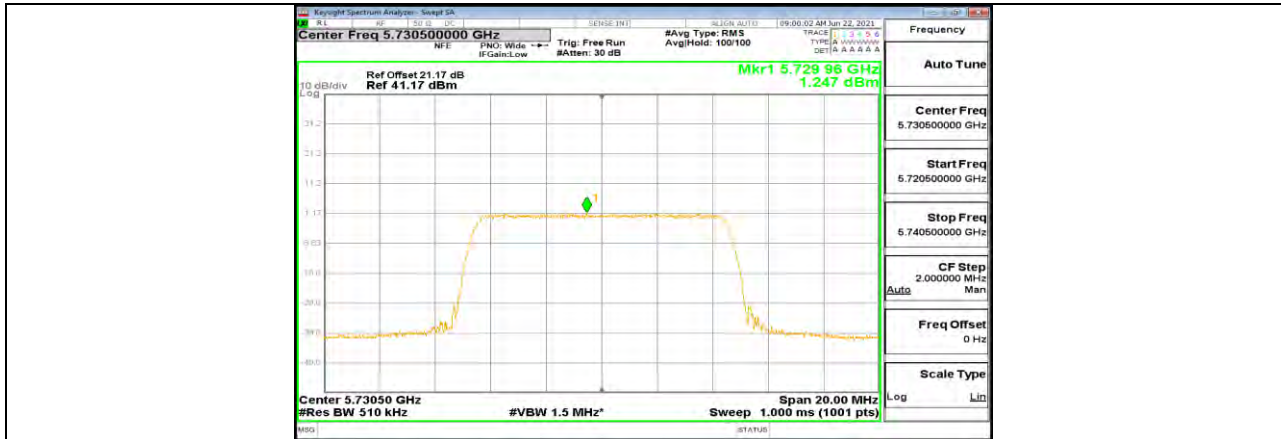

10M Ant0 5730.5

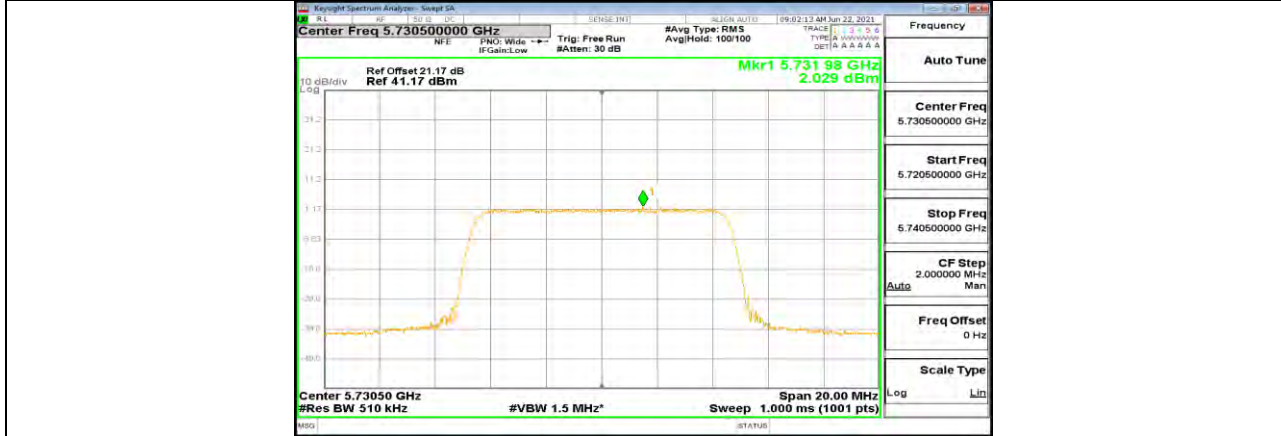

10M Ant1 5730.5



10M Ant0 5786.5

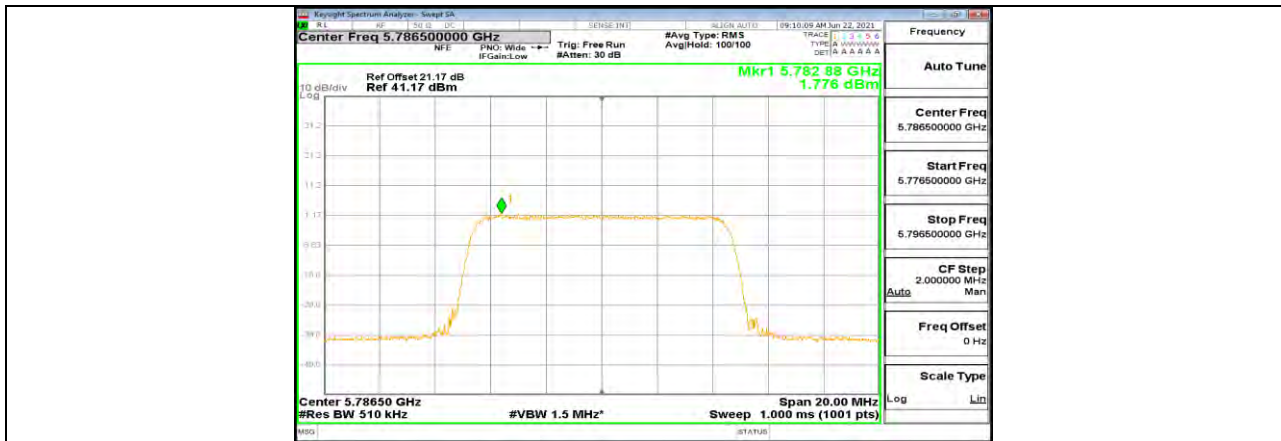

10M Ant1 5786.5

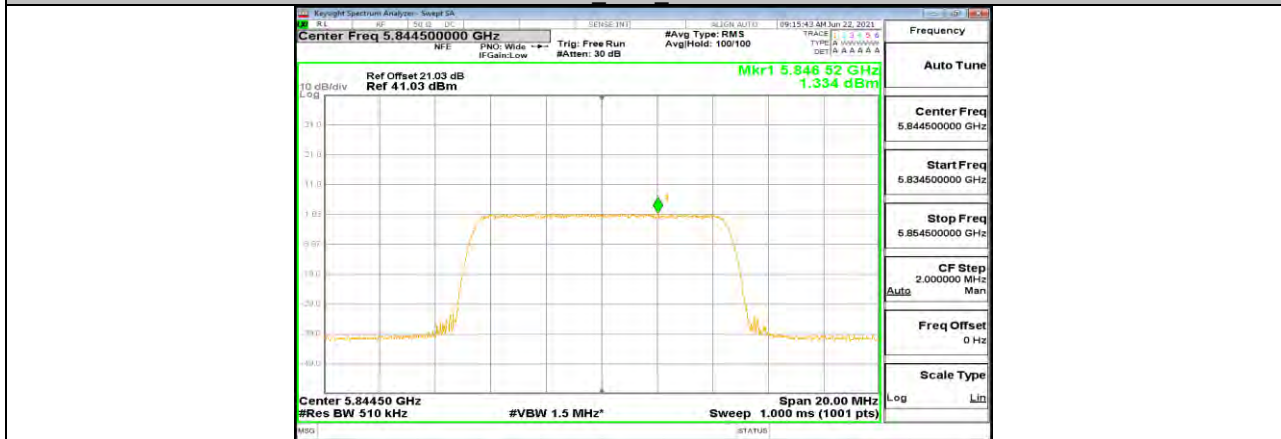

10M Ant0 5844.5

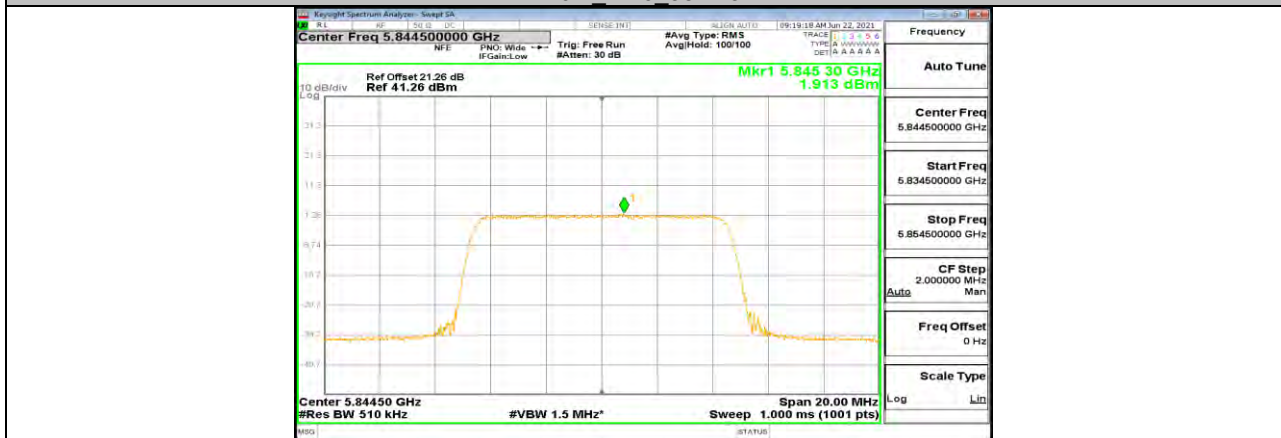

10M Ant1 5844.5









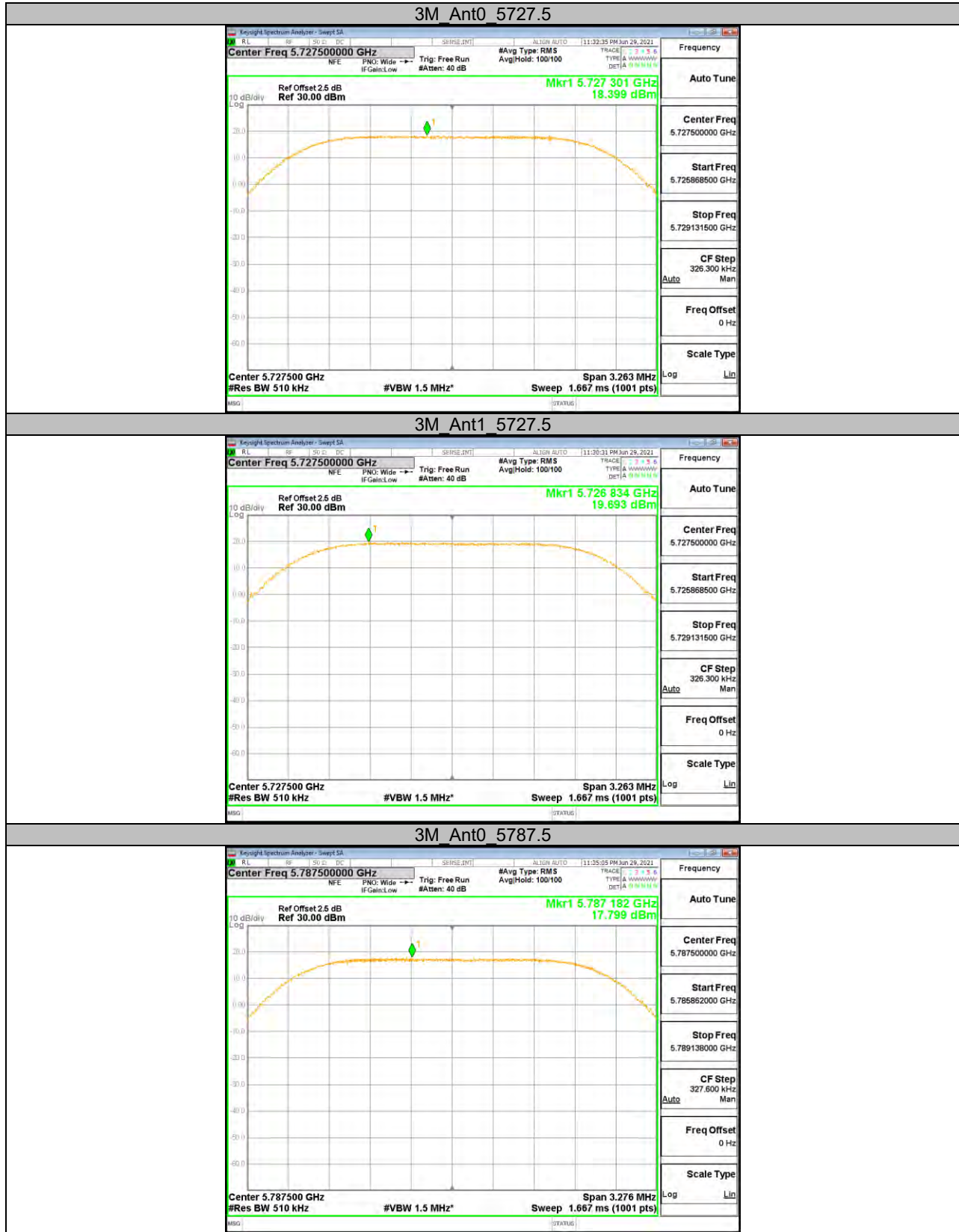

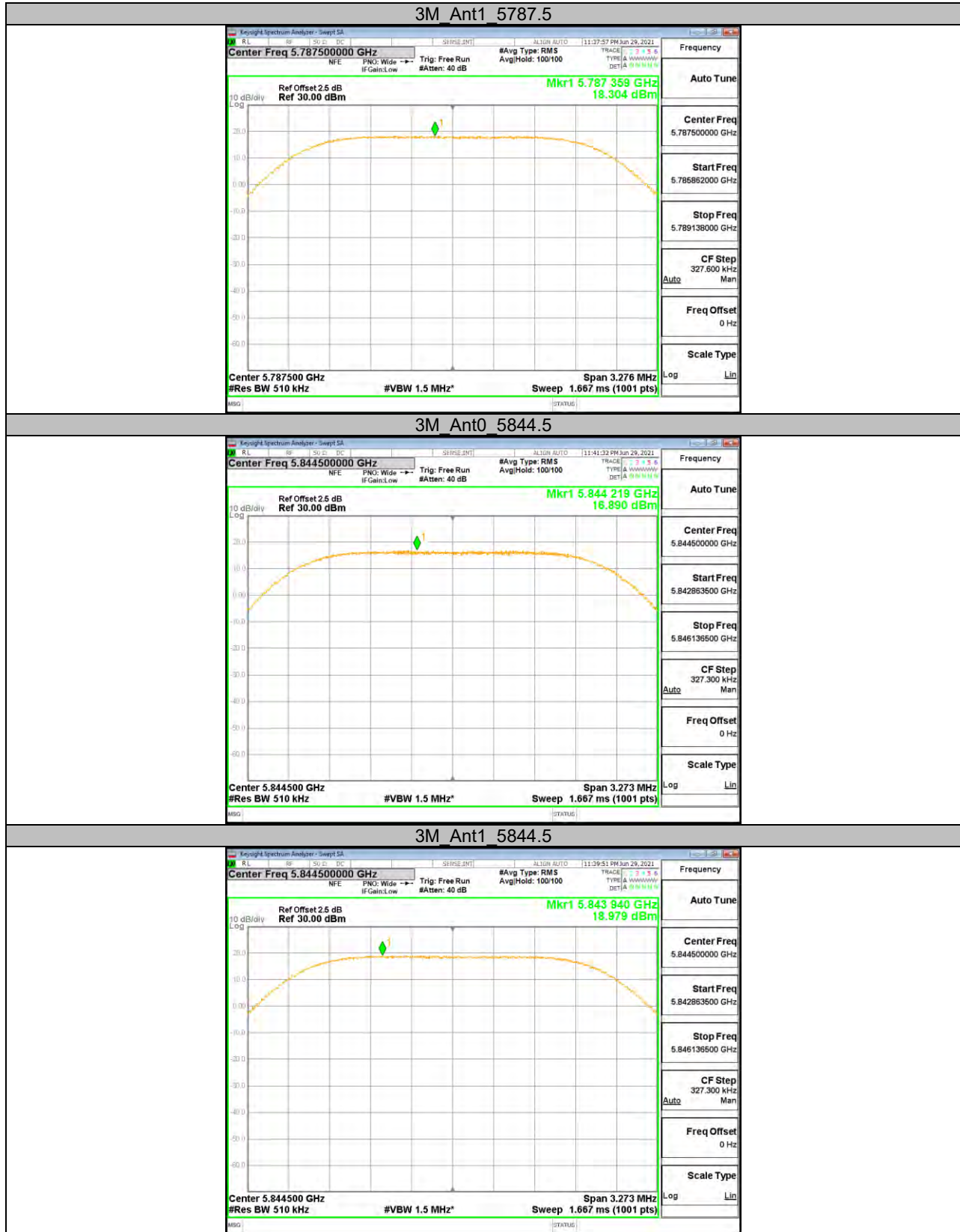



3M CA Ant0 5730.2



3M CA Ant1 5730.2



3M CA Ant0 5790.2



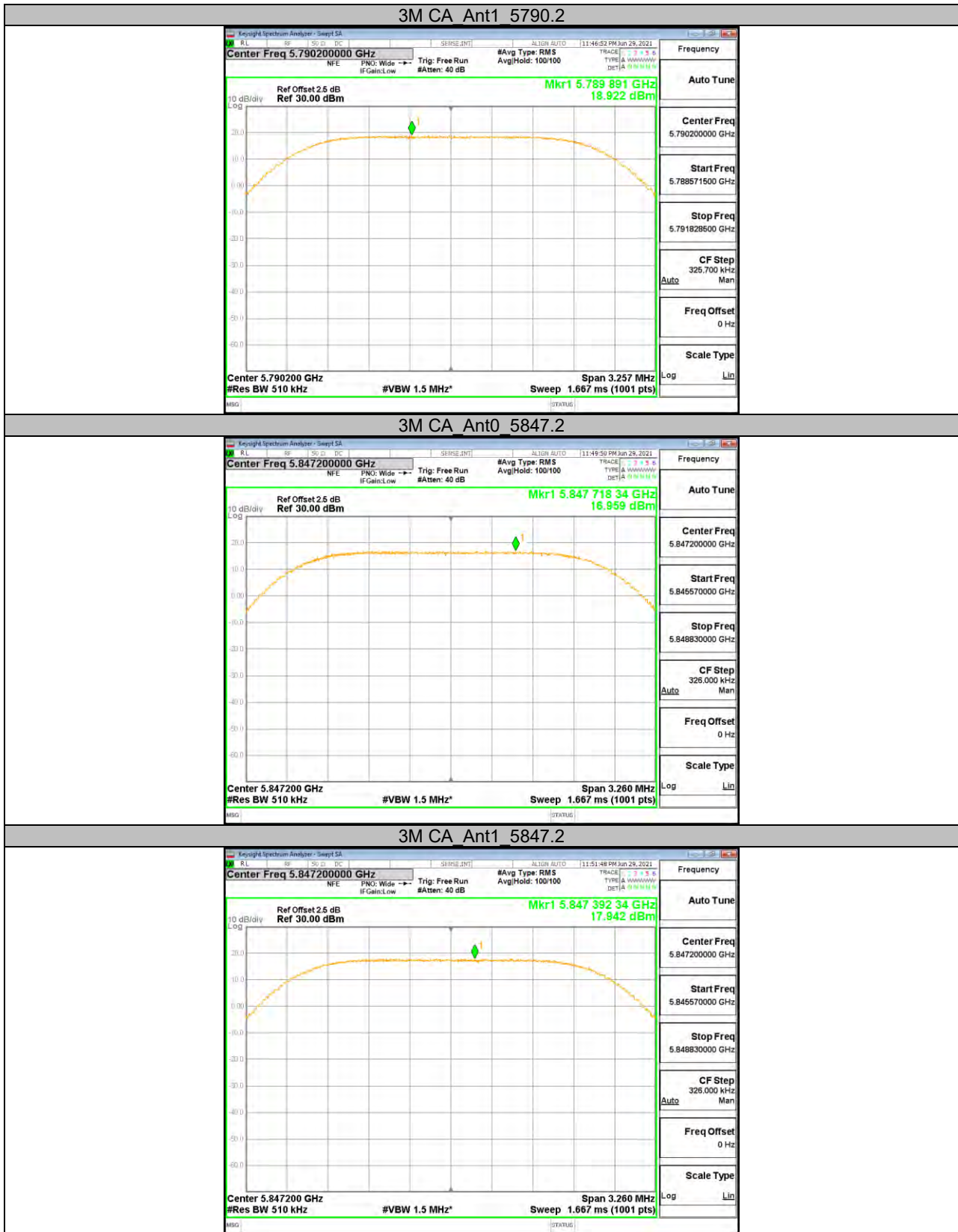



11.5. Appendix D: Duty Cycle

11.5.1. Test Result

Mode	On Time (msec)	Period (msec)	Duty Cycle x (Linear)	Duty Cycle (%)	Duty Cycle Correction Factor (dB)	1/T Minimum VBW (kHz)	Final setting For VBW (kHz)
20M	1	1	1.0000	100.00	0.00	1.00	0.01
40M	1	1	1.0000	100.00	0.00	1.00	0.01
10M	1	1	1.0000	100.00	0.00	1.00	0.01
1.4M	1	1	1.0000	100.00	0.00	1.00	0.01
1.4M CA	1	1	1.0000	100.00	0.00	1.00	0.01
3M	1	1	1.0000	100.00	0.00	1.00	0.01
3M CA	1	1	1.0000	100.00	0.00	1.00	0.01

Note:

Duty Cycle Correction Factor= $10\log(1/x)$.

Where: x is Duty Cycle (Linear)

Where: T is On Time

If that calculated VBW is not available on the analyzer then the next higher value should be used.



11.5.2. Test Graphs



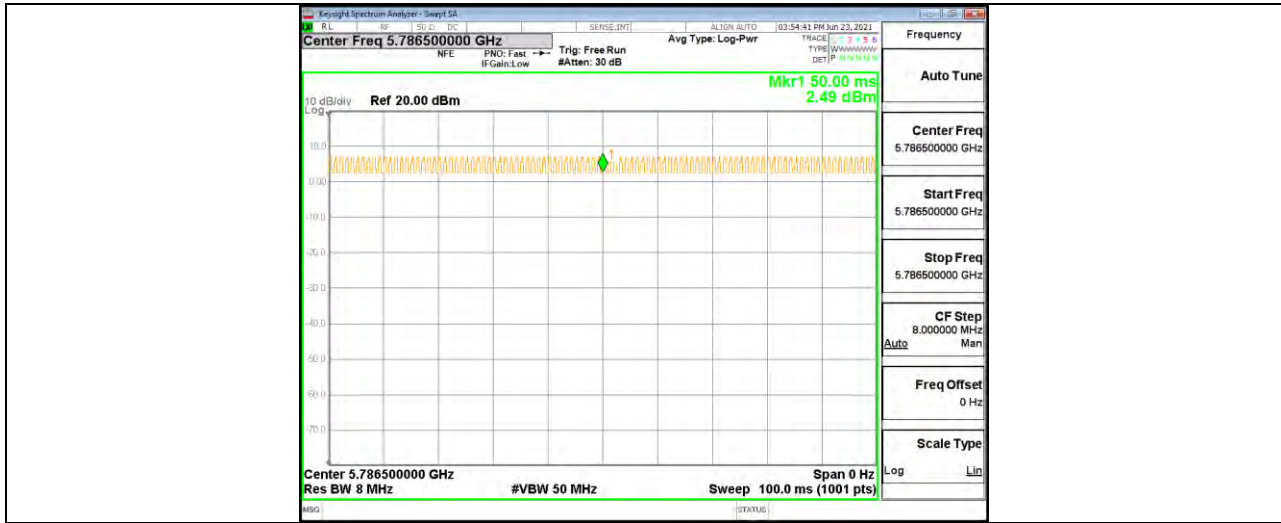

1.4M Ant1 5786.5



1.4M CA Ant1 5788.12



3M Ant1 5785.7

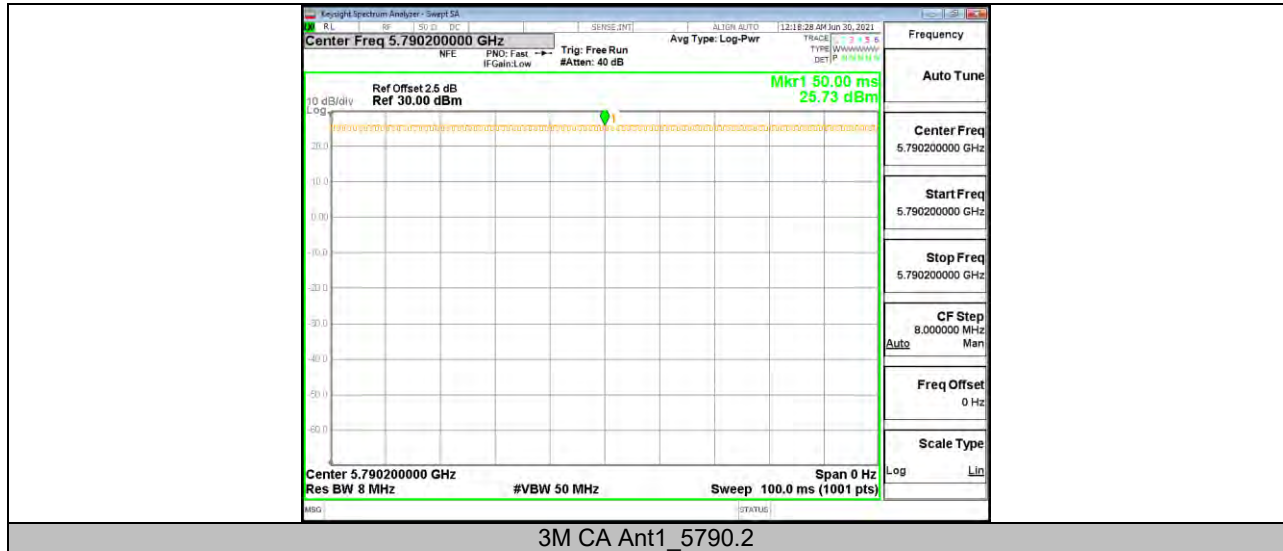

Note: All the modes have been tested, only the worst data was recorded in the report.



11.6. Appendix E: Frequency Stability

11.6.1. Test Result

Frequency Error vs. Voltage									
SRD 20M:5735.5MHz									
Temp.	Volt.	0 Minute		2 Minute		5 Minute		10 Minute	
		Freq.Error (MHz)	Tolerance (ppm)	Freq.Error (MHz)	Tolerance (ppm)	Freq.Error (MHz)	Tolerance (ppm)	Freq.Error (MHz)	Tolerance (ppm)
T _N	V _L	5735.5030	0.52	5735.5015	0.26	5735.4952	-0.83	5735.5116	2.03
T _N	V _N	5735.4769	-4.03	5735.5210	3.67	5735.4763	-4.13	5735.5013	0.22
T _N	V _H	5735.5058	1.01	5735.4893	-1.86	5735.4848	-2.66	5735.5133	2.32
Frequency Error vs. Temperature									
SRD 20M:5735.5MHz									
Temp.	Volt.	0 Minute		2 Minute		5 Minute		10 Minute	
		Freq.Error (MHz)	Tolerance (ppm)	Freq.Error (MHz)	Tolerance (ppm)	Freq.Error (MHz)	Tolerance (ppm)	Freq.Error (MHz)	Tolerance (ppm)
45	V _N	5735.4798	-3.53	5735.4768	-4.04	5735.5110	1.92	5735.5039	0.69
40	V _N	5735.4998	-0.03	5735.5151	2.63	5735.5190	3.31	5735.4914	-1.51
30	V _N	5735.4867	-2.33	5735.4959	-0.72	5735.5211	3.68	5735.4858	-2.47
20	V _N	5735.5215	3.76	5735.4900	-1.74	5735.4935	-1.14	5735.5034	0.59
10	V _N	5735.5228	3.98	5735.4993	-0.12	5735.5169	2.94	5735.4914	-1.50
0	V _N	5735.4975	-0.44	5735.5250	4.36	5735.5097	1.69	5735.4997	-0.05
-10	V _N	5735.5021	0.37	5735.5051	0.88	5735.5195	3.40	5735.4934	-1.15



Frequency Error vs. Voltage									
SRD 20M: 5839.5 MHz									
Temp.	Volt.	0 Minute		2 Minute		5 Minute		10 Minute	
		Freq.Error (MHz)	Tolerance (ppm)	Freq.Error (MHz)	Tolerance (ppm)	Freq.Error (MHz)	Tolerance (ppm)	Freq.Error (MHz)	Tolerance (ppm)
T _N	V _L	5839.4975	-0.42	5839.4801	-3.42	5839.4756	-4.18	5839.5008	0.14
T _N	V _N	5839.5115	1.97	5839.4857	-2.45	5839.4968	-0.55	5839.4763	-4.06
T _N	V _H	5839.5069	1.18	5839.4939	-1.05	5839.5162	2.78	5839.5159	2.72

Frequency Error vs. Temperature									
SRD 20M: 5839.5 MHz									
Temp.	Volt.	0 Minute		2 Minute		5 Minute		10 Minute	
		Freq.Error (MHz)	Tolerance (ppm)	Freq.Error (MHz)	Tolerance (ppm)	Freq.Error (MHz)	Tolerance (ppm)	Freq.Error (MHz)	Tolerance (ppm)
45	V _N	5839.4875	-2.15	5839.5222	3.80	5839.5066	1.13	5839.4827	-2.97
40	V _N	5839.4757	-4.16	5839.5215	3.69	5839.5062	1.06	5839.4980	-0.34
30	V _N	5839.4954	-0.78	5839.4793	-3.55	5839.5099	1.70	5839.5054	0.92
20	V _N	5839.5157	2.68	5839.5087	1.48	5839.5208	3.57	5839.5212	3.63
10	V _N	5839.4821	-3.06	5839.5178	3.05	5839.4807	-3.30	5839.4928	-1.23
0	V _N	5839.5035	0.59	5839.5070	1.20	5839.5033	0.57	5839.4869	-2.25
-10	V _N	5839.5246	4.21	5839.4973	-0.46	5839.4983	-0.30	5839.5229	3.92

Note: All the modes have been tested, only the worst data was recorded in the report.

END OF REPORT