



# ZTU Module Datasheet

Hardware Product Development > Cloud Module

Version: 20201126

## Contents

<b>1</b>	<b>Product overview</b>	<b>2</b>
1.1	Features . . . . .	2
1.2	Applications . . . . .	2
1.3	Change history . . . . .	2
<b>2</b>	<b>Module interfaces</b>	<b>3</b>
2.1	Dimensions and package . . . . .	3
2.2	Pin definition . . . . .	5
<b>3</b>	<b>Electrical parameters</b>	<b>9</b>
3.1	Absolute electrical parameters . . . . .	9
3.2	Normal working conditions . . . . .	9
3.3	TX and RX Power Consumption . . . . .	10
3.4	Working current . . . . .	10
<b>4</b>	<b>RF parameters</b>	<b>11</b>
4.1	Basic RF features . . . . .	11
4.2	TX performance . . . . .	11
4.3	RX performance . . . . .	12
<b>5</b>	<b>Antenna</b>	<b>13</b>
5.1	Antenna type . . . . .	13
5.2	Antenna interference reduction . . . . .	13
<b>6</b>	<b>Packaging information and production instructions</b>	<b>14</b>
6.1	Mechanical dimensions . . . . .	14
6.2	Side view . . . . .	16
6.3	The schematic diagram of a packaging . . . . .	17
6.4	The Diagram of PCB Packaging-pin header . . . . .	17
6.5	Production instructions . . . . .	20
6.6	Recommended oven temperature curve . . . . .	21
6.7	Storage conditions . . . . .	23
<b>7</b>	<b>MOQ and packaging information</b>	<b>24</b>

**8 Appendix: Statement**

**24**



ZTU is a low-power embedded Zigbee module that Tuya has developed. It consists of a highly integrated wireless RF processing chip (TLSR8258F1KAT32), a few peripherals, a built-in 802.15.4 PHYMAC Zigbee network protocol stack, and rich library functions. ZTU is embedded with a low-power 32-bit CPU, 1-MB flash program memory, a 64-KB RAM, and abundant peripheral resources.

## 1 Product overview

ZTU is a FreeRTOS platform that integrates all function libraries of the Zigbee MAC and TCP/IP protocols. You can develop embedded Zigbee products as required.

### 1.1 Features

- Embedded with low-power 32-bit CPU and ARM Cortex-M33 processor
- The clock rate: 48 MHz
- Wide working voltage: 1.8 to 3.6 V
- Peripherals: 9 general-purpose input/output (GPIO), 1 universal asynchronous receiver/transmitter (UART), and 1 analog-to-digital converter (ADC)
- Zigbee connectivity
  - Support 802.15.4 MAC/PHY
  - Working channels 11 to 26 @2.400 to 2.483 GHz, air interface rate: 250 Kbps
  - Up to +10dBm output power and dynamic output power>35 dB
  - 60 uA/MHz power consumption during running, 1.4-uA sleep current
  - The terminal equipment connects to the network actively.
  - Built-in onboard PCB antenna, Ipex connector reserved
  - Onboard PCB antenna with a gain of 1.08 dBi
  - Working temperature: -40°C to 125°C
  - Support hardware encryption and AES 128

### 1.2 Applications

- Intelligent building
- Smart household and home appliances
- Smart socket and light
- Industrial wireless control
- Baby monitor
- Network camera
- Intelligent bus

### 1.3 Change history

Update date	Updated content	Version after update
11/24/2020	This is the first release.	V1.0.0

## 2 Module interfaces

### 2.1 Dimensions and package

ZTU has 3 rows of pins with a  $1.4 \pm 0.1$  mm pin spacing.

The ZTU dimensions are  $20.3 \pm 0.35$  mm (W)  $\times$   $15.8 \pm 0.35$  mm (L)  $\times$   $3 \pm 0.15$  mm (H).

The dimensions of ZTU are as follows:

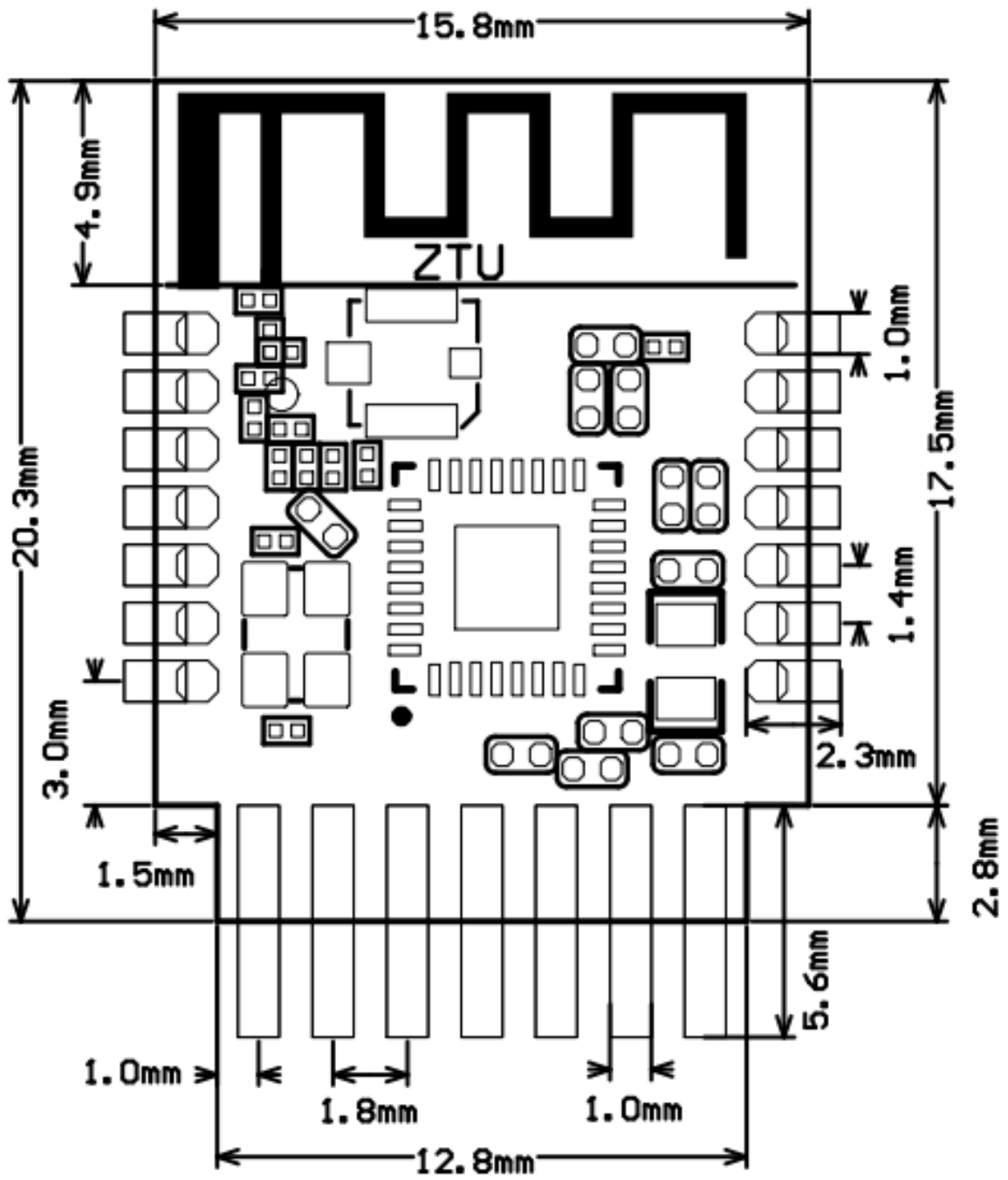

## 2.2 Pin definition

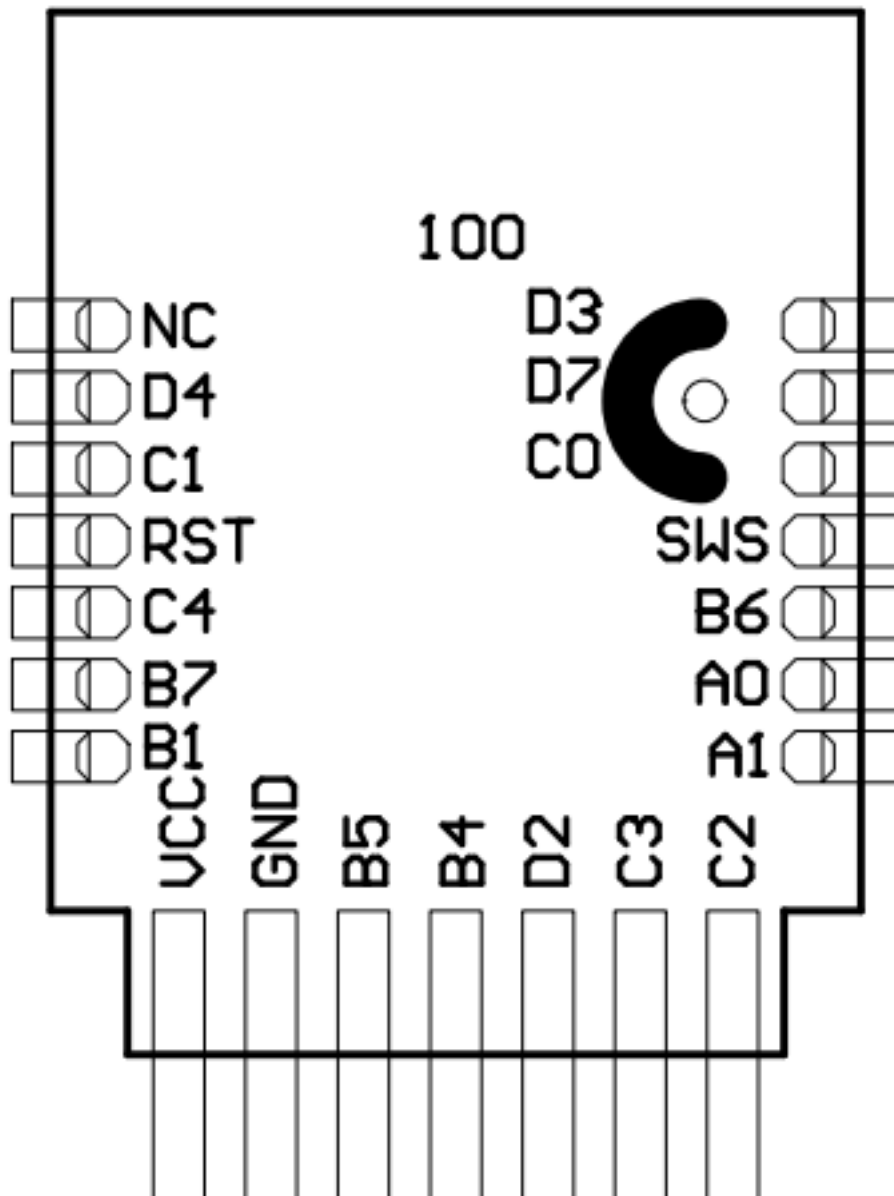

Pin number	Symbol	I/O type	Function
1	D3	I/O	Common I/O pin, which corresponds to D3 (Pin 32) of IC



Pin number	Symbol	I/O type	Function
2	D7	I/O	Common I/O pin, which corresponds to D7 (Pin 2) of IC
3	C0	I/O	Common I/O pin, which corresponds to C0 (Pin 20) of IC
4	SWS	I/O	Burning pin, which corresponds to SWS (Pin 5) of IC
5	B6	I/O	ADC pin, which corresponds to B6 (Pin 16) of IC
6	A0	I/O	Common I/O pin, which corresponds to A0 (Pin 3) of IC
7	A1	I/O	Common I/O pin, which corresponds to A1 (Pin 4) of IC
8	C2	I/O	Support hardware PWM and correspond to C2 (Pin 22) on the internal IC
9	C3	I/O	Support hardware PWM and correspond to C3 (Pin 23) on the internal IC

Pin number	Symbol	I/O type	Function
10	D2	I/O	Support hardware PWM and correspond to D2 (Pin 31) on the internal IC
11	B4	I/O	Support hardware PWM and correspond to B4 (Pin 14) on the internal IC
12	B5	I/O	Support hardware PWM and correspond to B5 (Pin 15) on the internal IC
13	GND	P	Power supply reference ground
14	VCC	P	Power supply pin (3.3V)
15	B1	I/O	Uart_TXD, which corresponds to B1 (Pin 6) of IC
16	B7	I/O	Uart_RXD, which corresponds to B7 (Pin 17) of IC
17	C4	I/O	ADC pin, which corresponds to C4 (Pin 16) of IC
18	RST	I/O	Reset pin, active low

---

Pin number	Symbol	I/O type	Function
19	C1	I/O	Common I/O pin, which corresponds to C1 (Pin 21) of IC
20	D4	I/O	Common I/O pin, which corresponds to D4 (Pin 1) of IC
21	NC	I/O	No connection

---

**Note:** P indicates a power supply pin and I/O indicates an input/output pin.

### 3 Electrical parameters

#### 3.1 Absolute electrical parameters

Parameter	Description	Minimum value	Maximum value	Unit
Ta	Working temperature	-40	125	°C
VBAT	Power supply voltage	1.8	3.6	V
Static electricity discharge voltage (human body model)	TAMB-25°C	-	2	KV
Static electricity discharge voltage (machine model)	TAMB-25°C	-	0.5	KV

#### 3.2 Normal working conditions

Parameter	Description	Minimum value	Typical value	Maximum value	Unit
Ta	Working temperature	-40	-	125	°C
VCC	Working voltage	1.8	3.3	3.6	V

Parameter	Description	Minimum value	Typical value	Maximum value	Unit
VIL	I/O low-level input	-	-	VDD*0.3	V
VIH	I/O high-level input	VDD*0.7	-	-	V
VOL	I/O low-level output	-	-	VDD*0.2	V
VOH	I/O high-level output	VDD*0.8	-	-	V

### 3.3 TX and RX Power Consumption

Working status	Mode	Rate	Transmit power/receive	Average value	Peak value (Typical value)	Unit
Transmit	-	250Kbps	+10 dBm	18	38	mA
Transmit	-	250Kbps	+0 dBm	6	34	mA
Receive	-	250Kbps	Constantly receive	5.3	38	mA

### 3.4 Working current

Working mode	Working status, Ta = 25°C	Average value	Maximum value (Typical value)	Unit
Quick network connection state	The module is in the fast network connection state	3	34	mA
Network connection state	The module is connected to the network	6	38	mA
Deep sleep mode	Deep sleep mode, reserve 32KB SRAM	1.4	-	uA

## 4 RF parameters

### 4.1 Basic RF features

Parameter	Description
Working frequency	2.405 to 2.480 GHz
Zigbee standard	IEEE 802.15.4
Data transmission rate	250 Kbps
Antenna type	PCB antenna with a gain of 1.08 dBi, ipex optional

### 4.2 TX performance

TX performance

Parameter	Minimum value	Typical value	Maximum value	Unit
Maximum output power (250 Kbps)	-	10	-	dBm
Minimum output power (250 Kbps)	-	-25	-	dBm
Output power adjustment stepping	-	0.5	1	dBm
Output spectrum adjacent channel suppression	-	-31	-	dBc
Frequency error	-15	-	15	ppm

### 4.3 RX performance

#### RX sensitivity

Parameter	Minimum value	Typical value	Maximum value	Unit
PER<8%, RX sensitivity (250 Kbps)	-102	-101	-99	dBm

## 5 Antenna

### 5.1 Antenna type

ZTU uses only an onboard PCB antenna.

### 5.2 Antenna interference reduction

To ensure the optimal Wi-Fi performance when the Zigbee module uses an onboard PCB antenna, it is recommended that the antenna be at least 15 mm away from other metal parts. To prevent an adverse impact on the antenna radiation performance, avoid copper or traces along the antenna area on the PCB.

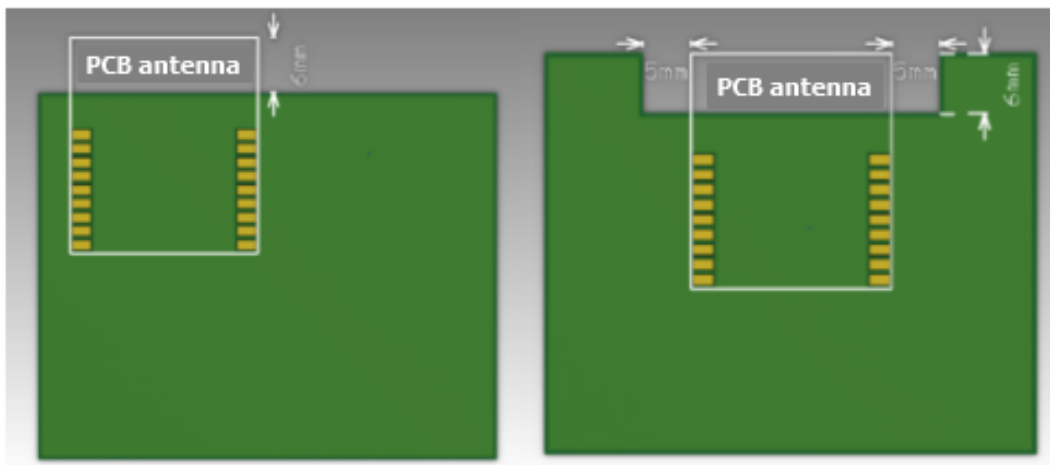





## 6 Packaging information and production instructions

### 6.1 Mechanical dimensions

The PCB dimensions are  $20.3 \pm 0.35$  mm (L)  $\times$   $15.8 \pm 0.35$  mm (W)  $\times$   $3 \pm 0.15$  mm (H).

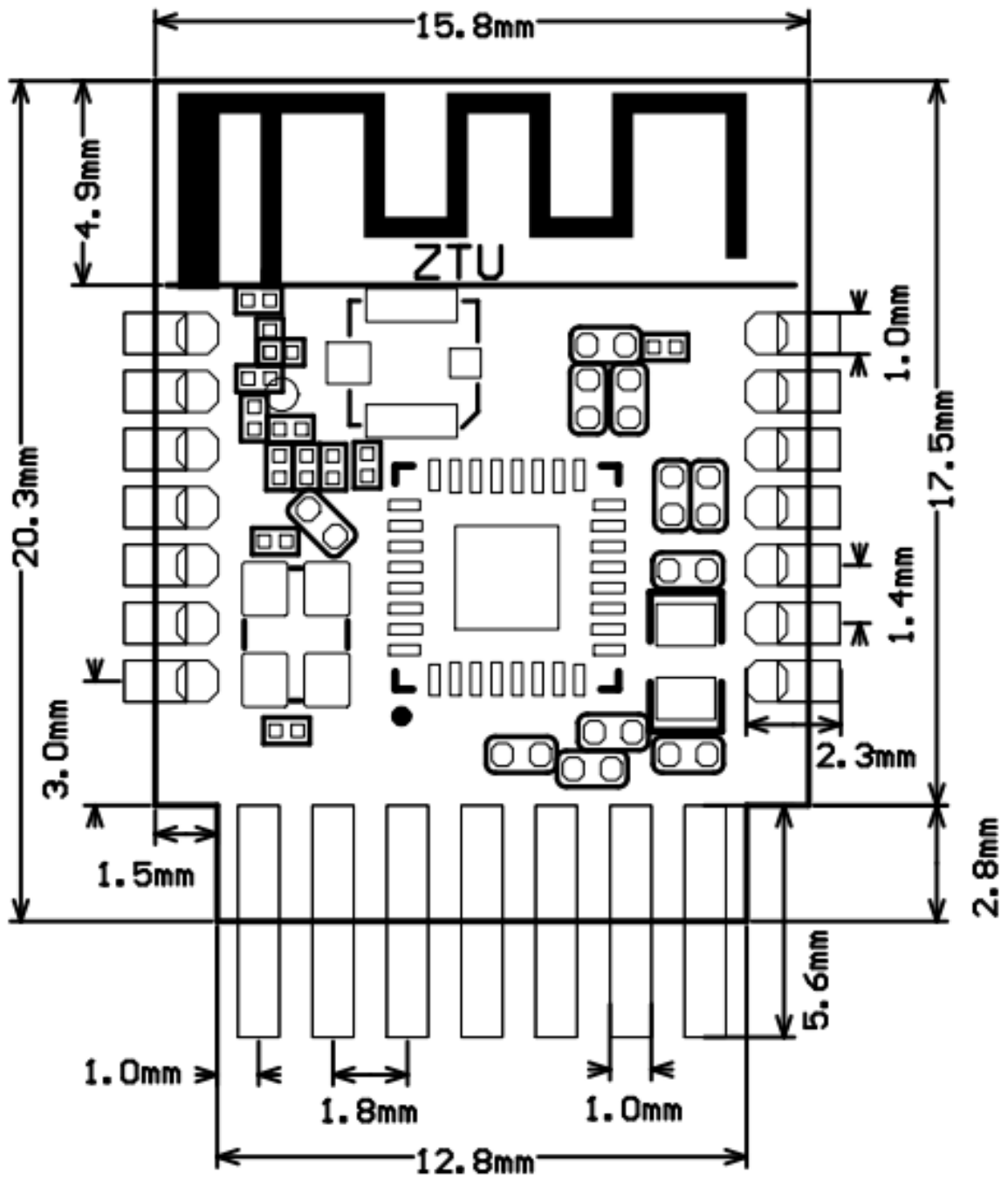

### 6.2 Side view

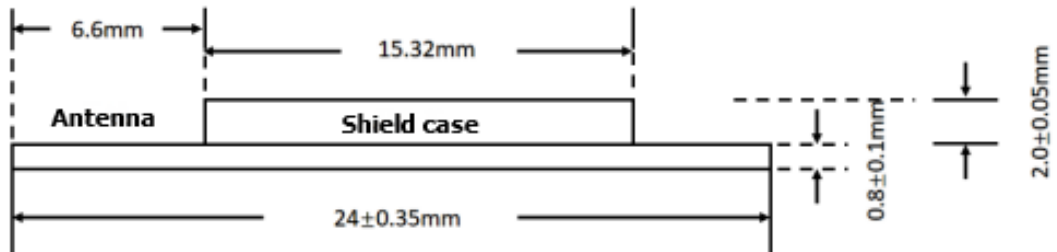

### 6.3 The schematic diagram of a packaging

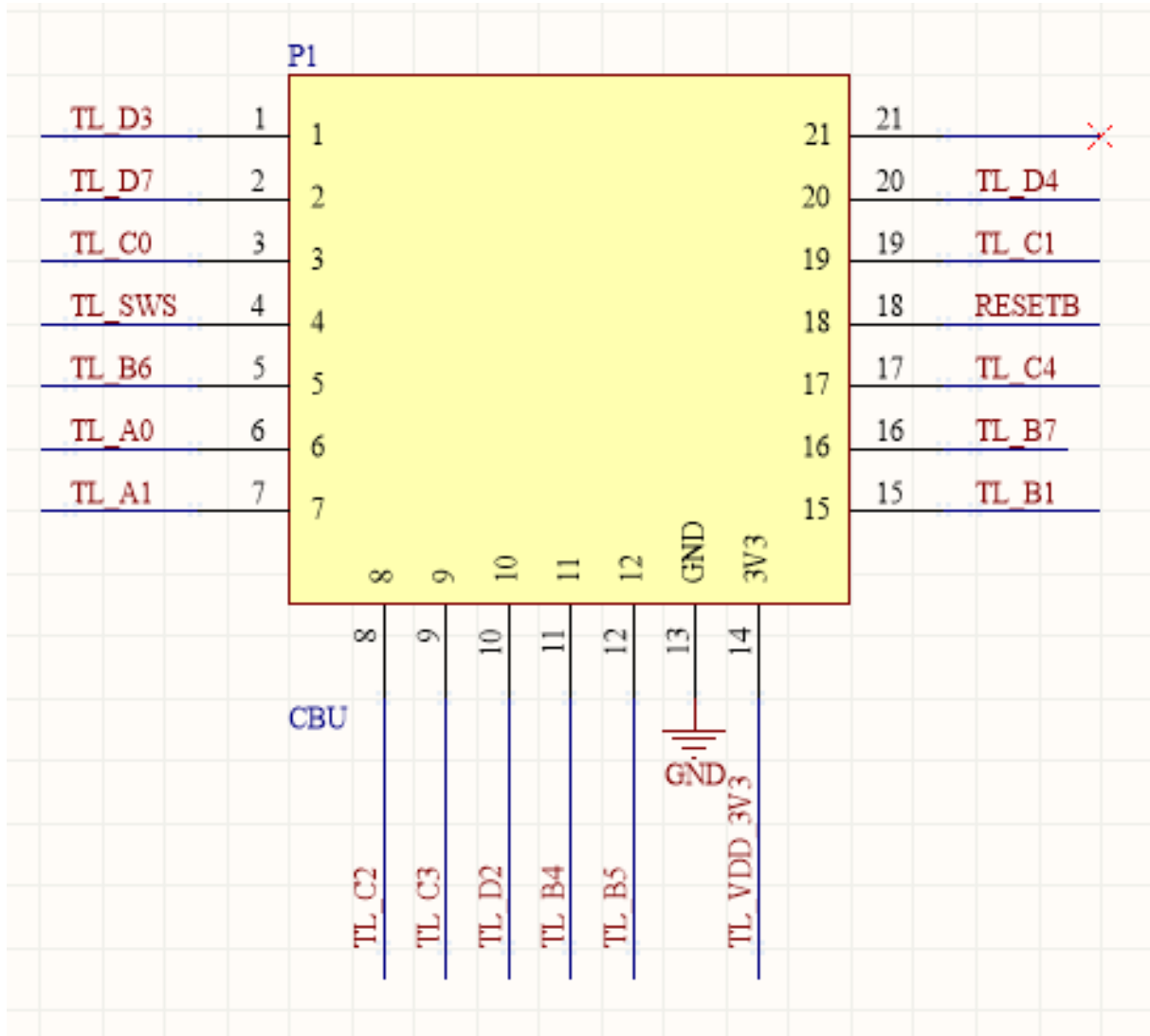

### 6.4 The Diagram of PCB Packaging-pin header

ZTU can choose SMT placement or pin header plug-in. The dimensions of the plug-in are as follows:

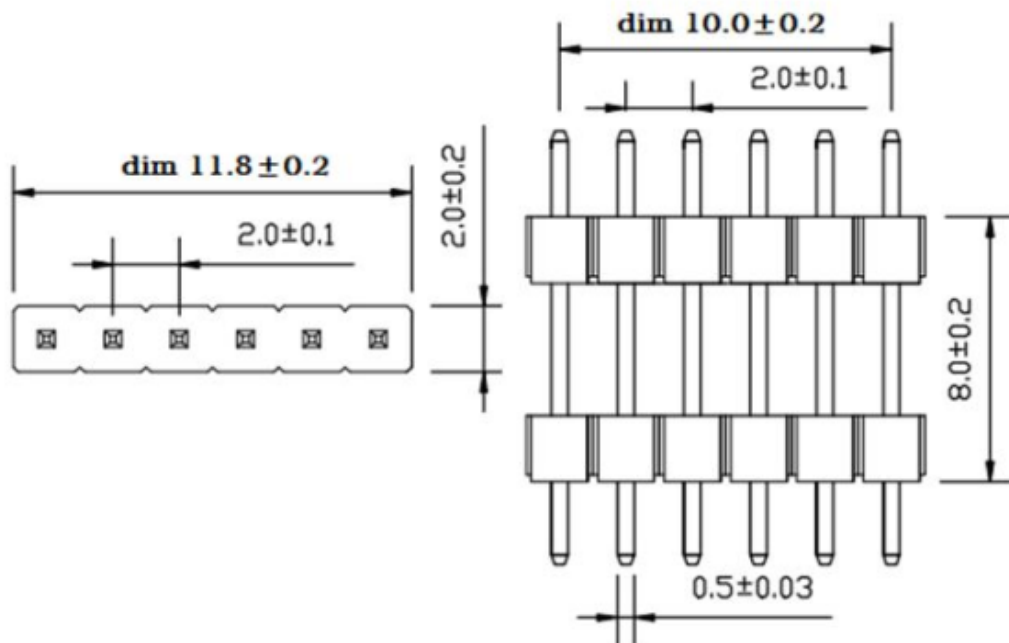

6.4.1 PCB Packaging Diagram-SMT

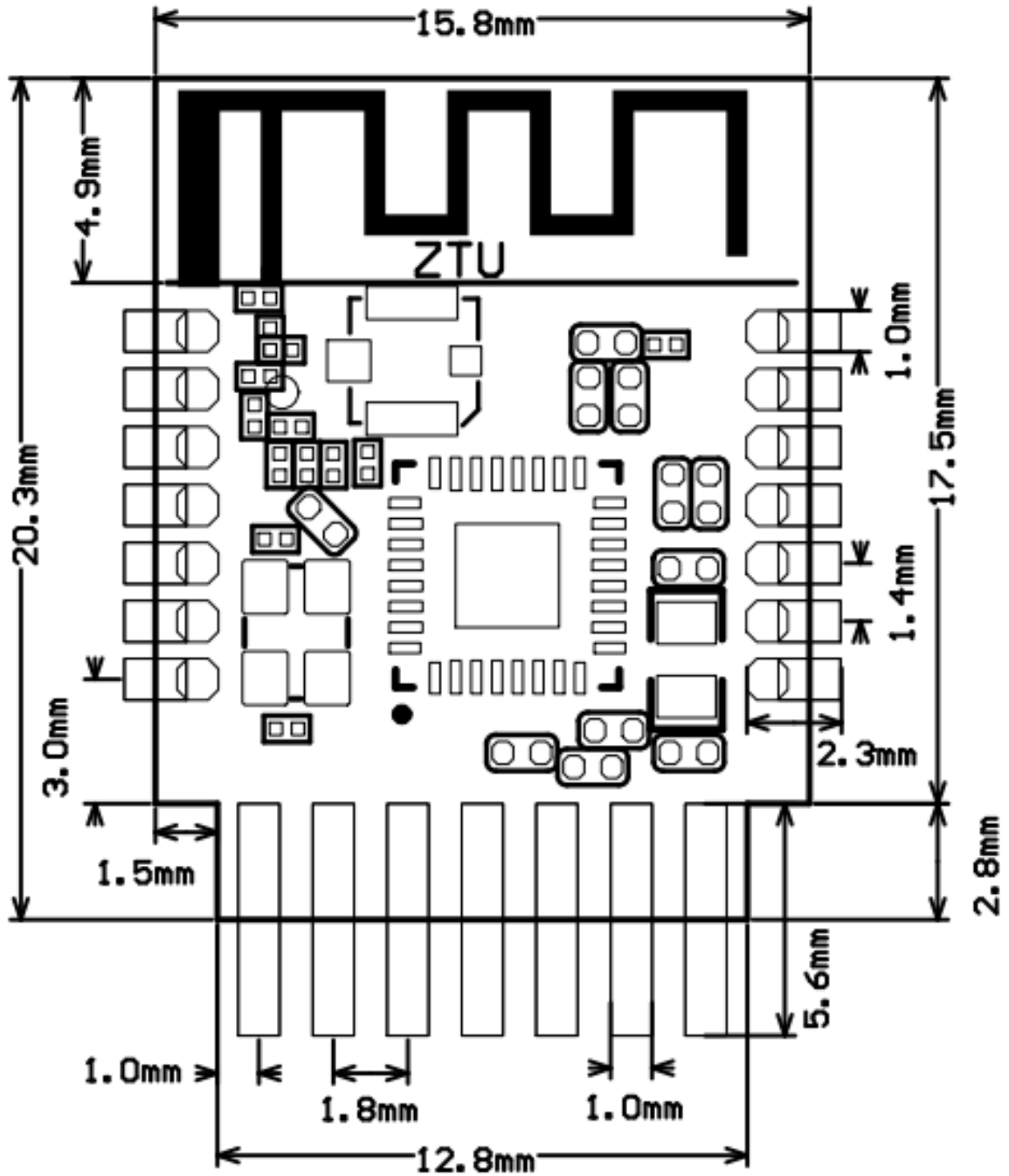

## 6.5 Production instructions

1. Mount Tuya's stamp hole package module with an SMT machine within 24 hours after unpacking and burning the firmware. Otherwise, the module must be packaged again under vacuum. The module must be baked before mounting.

- SMT equipment
  - Reflow soldering machine
  - Automated optical inspection (AOI) equipment
  - Nozzle with a 6 to 8 mm diameter
- Baking equipment:
  - Cabinet oven
  - Anti-static heat-resistant trays
  - Anti-static heat-resistant gloves

2. Storage conditions for a delivered module are as follows:

- The moisture-proof bag must be placed in an environment where the temperature is below 30°C and the relative humidity is lower than 70%.
- The shelf life of a dry-packaged product is 6 months from the date when the product is packaged and sealed.
- The package contains a humidity indicator card (HIC).

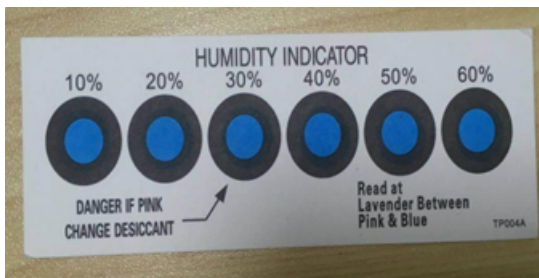

3. Bake a module based on HIC status as follows when you unpack the module package:

- If the 30%, 40%, and 50% circles are blue, bake the module for 2 consecutive hours.
- If the 30% circle is pink, bake the module for 4 consecutive hours.
- If the 30% and 40% circles are pink, bake the module for 6 consecutive hours.
- If the 30%, 40%, and 50% circles are pink, bake the module for 12 consecutive hours.

#### 4. Baking settings:

- Baking temperature:  $125\pm 5^{\circ}\text{C}$
- Alarm temperature:  $130^{\circ}\text{C}$
- SMT ready temperature: naturally cooling temperature:  $< 36^{\circ}\text{C}$
- The number of drying times: 1
- Rebaking condition: The module is not soldered within 12 hours after baking.

5. Do not use SMT to process modules that have been unpacked for more than 3 months, because electroless nickel/immersion gold (ENIG) is used for PCBs and they are seriously oxidized for over 3 months. SMT is very likely to cause pseudo and missing soldering. Tuya is not liable for such problems and consequences.

6. Before using SMT, take electrostatic discharge (ESD) protective measures.

7. To reduce the reflow defect rate, draw 10% of the products for visual inspection and AOI before the first mounting, to determine the rationality of oven temperature control and component attachment and placement manners. Draw 5 to 10 modules from subsequent batches each hour for visual inspection and AOI.

### **6.6 Recommended oven temperature curve**

Perform SMT based on the following reflow oven temperature curve. The highest temperature is  $245^{\circ}\text{C}$ . The reflow temperature curve is as below:



Refer to IPC/JEDEC standard; Peak Temperature: <math><245^{\circ}\text{C}</math>; Number of Times:  $\leq 2$  times;

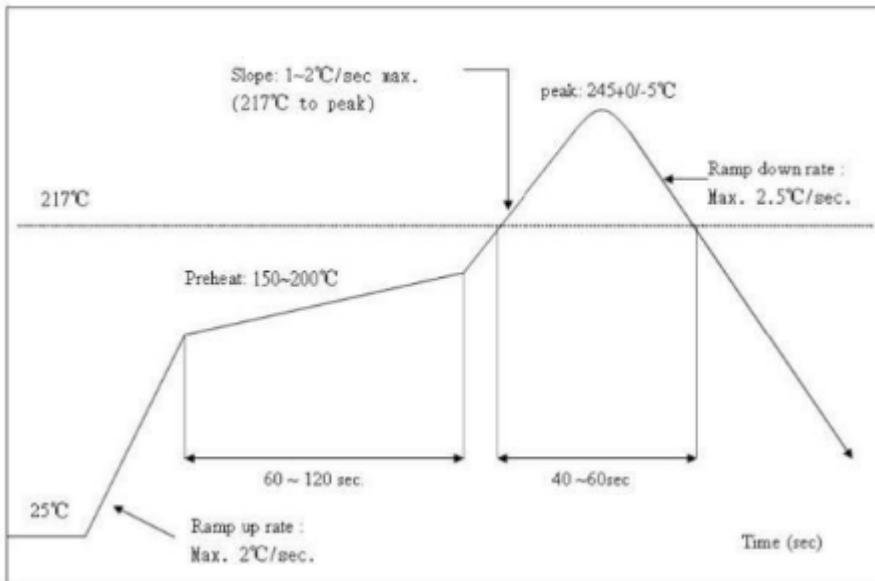

6.7 Storage conditions

	<p><b>CAUTION</b> This bag contains <b>MOISTURE-SENSITIVE DEVICES</b></p>	<p><b>LEVEL</b> <b>3</b></p>
<p>If Blank, see adjacent bar code label</p>		
<p>1. Calculated shelf life in sealed bag: 12 months at &lt; 40°C and &lt; 90% relative humidity (RH)</p>		
<p>2. Peak package body temperature: <u>260</u> °C <small>If Blank, see adjacent bar code label</small></p>		
<p>3. After bag is opened, devices that will be subjected to reflow solder or other high temperature process must</p>		
<p>a) Mounted within: <u>168</u> hrs. of factory conditions <small>If Blank, see adjacent bar code label</small></p>		
<p>≤ 30°C/60%RH, OR</p>		
<p>b) Stored at &lt;10% RH</p>		
<p>4. Devices require bake, before mounting, if:</p>		
<p>a) Humidity Indicator Card is &gt; 10% when read at 23 ± 5°C</p>		
<p>b) 3a or 3b not met.</p>		
<p>5. If baking is required, devices may be baked for 48 hrs. at 125 ± 5°C</p>		
<p>Note: If device containers cannot be subjected to high temperature or shorter bake times are desired, reference IPC/JEDEC J-STD-033 for bake procedure</p>		
<p>Bag Seal Date: _____ <small>If Blank, see adjacent bar code label</small></p>		
<p>Note: Level and body temperature defined by IPC/JEDEC J-STD-020</p>		

## 7 MOQ and packaging information

Product number	MOQ (pcs)	Shipping packaging method	The number of modules per reel	The number of reels per carton
ZTU	4000	Tape reel	1000	4

## 8 Appendix: Statement

**FCC Caution:** Any changes or modifications not expressly approved by the party responsible for compliance could void the user’s authority to operate this device.

This device complies with Part 15 of the FCC Rules. Operation is subject to the following two conditions: (1) This device may not cause harmful interference, and (2) this device must accept any interference received, including interference that may cause undesired operation.

**Note:** This device has been tested and found to comply with the limits for a Class B digital device, according to part 15 of the FCC Rules. These limits are designed to provide reasonable protection against harmful interference in a residential installation. This device generates, uses, and can radiate radio frequency energy and, if not installed and used following the instructions, may cause harmful interference to radio communications. However, there is no guarantee that interference will not occur in a particular installation.

If this device does cause harmful interference to radio or television reception, which can be determined by turning the device off and on, the user is encouraged to try to correct the interference by one or more of the following measures:

- Reorient or relocate the receiving antenna.
- Increase the separation between the device and receiver.
- Connect the device into an outlet on a circuit different from that to which the receiver is connected.
- Consult the dealer or an experienced radio/TV technician for help.

### Radiation Exposure Statement

This device complies with FCC radiation exposure limits set forth for an uncontrolled

rolled environment. This device should be installed and operated with a minimum distance of 20cm between the radiator and your body.

### **Important Note**

This radio module must not be installed to co-locate and operating simultaneously with other radios in the host system except following FCC multi-transmitter product procedures. Additional testing and device authorization may be required to operate simultaneously with other radios.

The availability of some specific channels and/or operational frequency bands are country dependent and are firmware programmed at the factory to match the intended destination. The firmware setting is not accessible by the end-user.

The host product manufacturer is responsible for compliance with any other FCC rules that apply to the host not covered by the modular transmitter grant of certification. The final host product still requires Part 15 Subpart B compliance testing with the modular transmitter installed.

The end-user manual shall include all required regulatory information/warnings as shown in this manual, including “This product must be installed and operated with a minimum distance of 20 cm between the radiator and user body”.

This device has got an FCC ID: 2ANDL-ZTU. The end product must be labeled in a visible area with the following: “Contains Transmitter Module FCC ID: 2ANDL-ZTU”.

This device is intended only for OEM integrators under the following conditions: The antenna must be installed such that 20cm is maintained between the antenna and users, and 2) The transmitter module may not be co-located with any other transmitter or antenna.

As long as the 2 conditions above are met, further transmitter tests will not be required. However, the OEM integrator is still responsible for testing their end-product for any additional compliance requirements required with this module installed.

### **Declaration of Conformity European Notice**



Hereby, Hangzhou Tuya Information Technology Co., Ltd declares that this module product is in compliance with essential requirements and other relevant provisions

of Directive 2014/53/EU,2011/65/EU. A copy of the Declaration of conformity can be found at <https://www.tuya.com>.



This product must not be disposed of as normal household waste, in accordance with the EU directive for waste electrical and electronic equipment (WEEE-2012/19/EU). Instead, it should be disposed of by returning it to the point of sale, or to a municipal recycling collection point.

The device could be used with a separation distance of 20cm to the human body.