



## TuyaSmartWi-Fi Module

### 1. Product Overview

WR3 is a low power consumption module with built-in Wi-Fi connectivity solution designed by Hangzhou Tuya Information Technology Co.,Ltd. The Wi-Fi Module consists of a highly integrated wireless radio chip W302 12E75M2 and some extra flash that has been programmed with Wi-Fi network protocol and plenty of software examples.WR3 includea ARM CM4F, WLAN MAC, 1T1R WLAN, maximum frequency reaches 125MHz, 256K SRAM, 1M byte flash and various peripheral resources.

WR3 is a RTOS platform, embedded with all the Wi-Fi MAC and TCP/IP protocol function examples, users can customize their Wi-Fi product by using these software examples.

Figure 1 shows the block diagramof the WR3.

Figure 1. The block diagram of the WR3

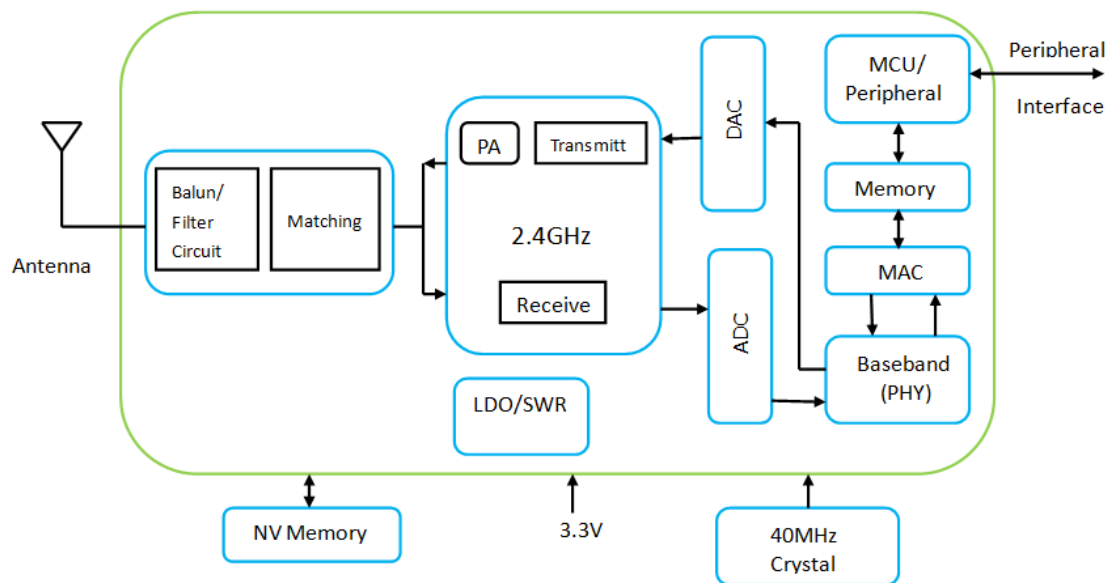

#### 1.1 Features

- ✧ Integrated low power consumption 32-bit CPU, also known as application processor
- ✧ Basic frequency of the CPU can support 125 MHz
- ✧ Supply voltage: DC 3.3V
- ✧ Peripherals: 7 GPIO channels, 2 UART, 1 ADC
- ✧ Wi-Fi connectivity:
  - 802.11 B/G/N20/N40
  - Channel 1 to 11 @ 2.4GHz
  - Support WPA/WPA2
  - +20.09dBm output power in 802.11b mode

- Support SmartConfig function for both Android and IOS devices
- On-board PCB antenna
- Operating temperature range: -20°C to 105°C

## **1.2 Main ApplicationFields**

- ✧ Intelligent Building
- ✧ Intelligent home, Intelligent household applications
- ✧ Healthy devices
- ✧ Industrial wireless control
- ✧ Baby monitor
- ✧ Webcam
- ✧ Intelligent bus

## 2. Dimensions and Footprint

### 2.1 Dimensions

WR3 has 2 columns of Pins (2\*8).The distance between each Pin is 1.5 mm. Size of WR3: 16mm(W)\*24mm(L)\*3.3mm(H)

Figure 2 shows the dimensions of WR3.

Figure 2.1. The dimensions of WR3

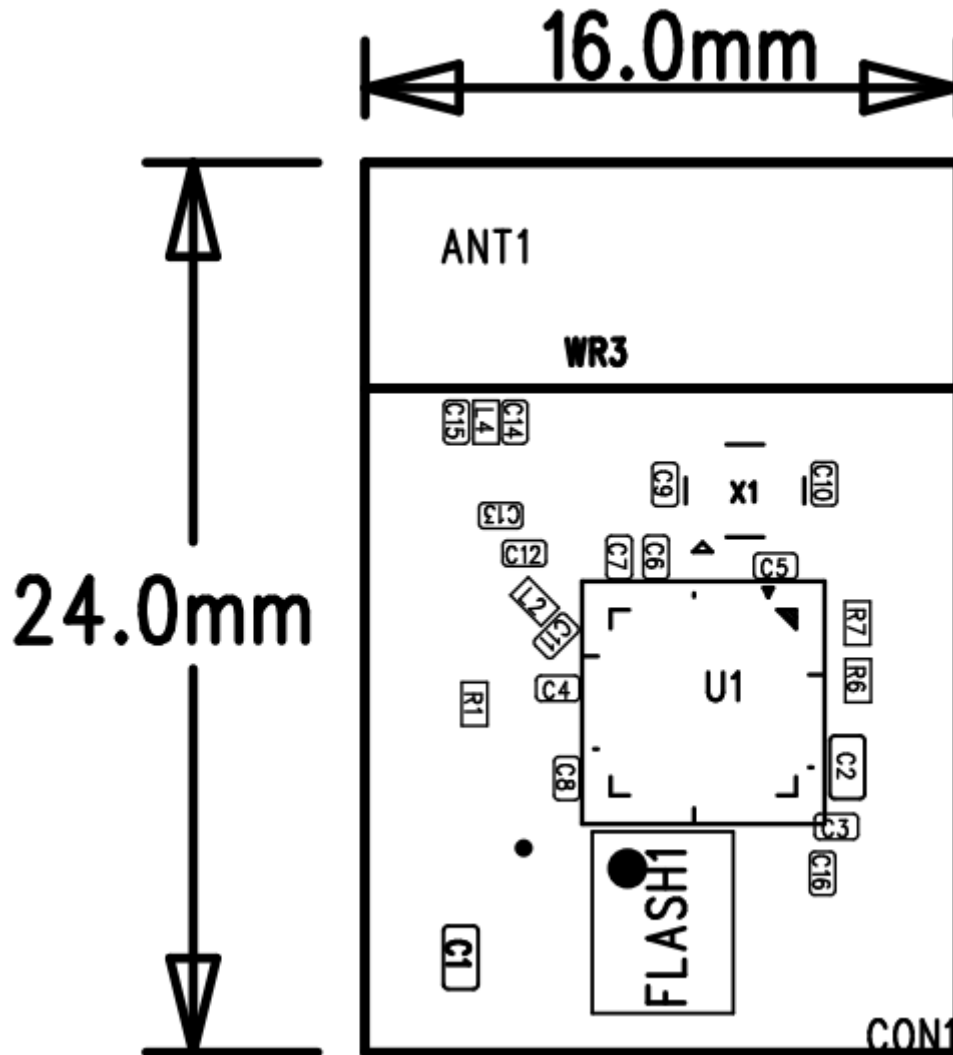

### 2.2 Pin Definition

Table 1 shows the general pin attributes of WR3

Table 1. The typical pin definition of WR3

PIN NO.	NAME	TYPE	DISCREPTION
1	NC	/	NC
2	GPIOA_2	I/O	GPIOA_22

WR3 DATASHEET

3	CHIP_EN	I/O	External reset singal(low level effects)
4	GPIOA_1 9	I/O	GPIOA_19
5	GPIOA_1 4	I/O	GPIOA_14, hardware PWM
6	GPIOA_1 5	I/O	GPIOA_15, hardware PWM
7	GPIOA_0	I/O	GPIOA_0, can not be pull-up while booting, can be used as GPIO while in normal working mode
8	VD33	P	Supply voltage (3.3V)
9	GND	P	Ground
10	ADC	AI	ADC terminal(input 5V maximumly)
11	GPIOA_2 9	I/O	UART_Log_RXD (used to print module's internal information)
12	GPIOA_3 0	I/O	UART_Log_TXD(used to print module's internal information)
13	GPIOA_5	I/O	GPIOA_5, hardware PWM
14	GPIOA_1 2	I/O	GPIOA_12, hardware PWM
15	RXD	I/O	UART0_RXD
16	TXD	I/O	UART0_TXD

Note: S: Power supply pins; I/O: Digital input or output pins; AI: Analog input.

### 3. Electrical Characteristics

#### 3.1 Absolute Maximum Ratings

Table 3.1. Absolute Maximum Ratings

PARAMETERS	DESCRIPTION	MIN	MAX	UNIT
Ts	Storage temperature	-20	105	°C
VCC	Supply voltage	3.0	3.6	V
Static electricity voltage (human model)	TAMB-25°C	-	2	KV
Static electricity voltage (machine model)	TAMB-25°C	-	0.5	KV

#### 3.2 Electrical Conditions

Table 3.2. Electrical Conditions

PARAMETERS	DESCRIPTION	MIN	TYPICAL	MAX	UNIT
Ta	Working temperature	-20	-	105	°C
VCC	Working voltage	3	3.3	3.6	V
VIL	IO low level input	-0.3	-	VCC*0.25	V
VIH	IO high level input	VCC*0.75	-	VCC	V
VOL	IO low level output	-	-	VCC*0.1	V
VoH	IO high level output	VCC*0.8	-	VCC	V
I <sub>max</sub>	IO drive current	-	-	16	mA
C <sub>pad</sub>	Input capacitor	-	2	-	pF

#### 3.3 Wi-Fi Transmitting Current Consumptions

Table 3.3. Wi-Fi TX current consumption

PARAMETERS	MODE	RATE	Transmitting power	TYPICAL	UNIT
IRF	11b	1Mbps	+20.09dBm	287	mA
IRF	11g	6Mbps	+20.06dBm	255	mA
IRF	11n HT20	MCS0	+19.99dBm	244	mA
IRF	11n HT40	MCS0	+19.76dBm	220	mA

### 3.4 Wi-Fi Receiving CurrentConsumptions

Table 3.4. Wi-Fi RX currentconsumption

PARAMETERS	MODE	TYPICAL	UNIT
IRF	CPU sleep	90	mA
IRF	CPU active	120	mA

### 3.5 Working Mode CurrentConsumptions

Table 3.5. The module working currentconsumption

WORK MODE	AT TA=25°C	TYPICAL	MAX*	UNIT
EZ Mode	WR3 is under EZ paring mode, Wi-Fi indicator light flashes quickly	121.8	141	mA
Standby Mode	WR3 is connected, Wi-Fi indicator light is on	52	125	mA
Operation Mode	WR3 is connected, Wi-Fi indicator light is on	180	312	mA
Disconnection Mode	WR3 is disconnected, Wi-Fi indicator light is off	46	120	mA

Note: peak continuous time is about 5us.

The parameter shown above will vary dependinon different firmware functions.

## 4. WLAN Radio Specification

### 4.1 Basic Radio Frequency Characteristics

Table 41.Basic Radio frequency characteristics

PARAMETERS	DESCRIPTION
Frequency band	2.412GHz to 2.462GHz
Wi-Fi standard	IEEE 802.11n20/g/b (Terminal 1-11),802.11n40( Terminal 1-7)
Data transmitting rate	11b:1,2,5.5,11(Mbps)
	11g:6,9,12,18,24,36,48,54(Mbps)
	11n:HT20,MCS0~7
	11n:HT40,MCS0~7
Antenna type	On-board PCB Antenna

### 4.2Wi-Fi TransmittingPower

Table 4.2. Wi-Fi transmitting power

PARAMETERS	MIN	TYPICAL	MAX	UNI T
------------	-----	---------	-----	----------

RF average output power, 802.11b CCK Mode	1M	-	20.09	-	dBm
RF average output power, 802.11g OFDM Mode	6M	-	20.06	-	dBm
RF average output power, 802.11n20 OFDM Mode	MCS0	-	19.99	-	dBm
RF average output power, 802.11n40 OFDM Mode	MCS0	-	19.76	-	dBm
The Frequency error		-10	-	10	ppm

### 4.3 Wi-Fi Receiving Sensitivity

Table 4.3. Wi-Fi Receiving sensitivity

PARAMETERS		MIN	TYPICAL	MAX	UNIT
PER<8%, Receiving sensitivity, 802.11b CCK Mode	1M	-	-91	-	dBm
PER<10%, Receiving sensitivity, 802.11g OFDM Mode	6M	-	-75	-	dBm
PER<10%, Receiving sensitivity, 802.11n OFDM Mode	MCS0	-	-72	-	dBm

## **5. Antenna Information**

### **5.1 Antenna Type**

Antenna connected using On-board PCB antenna.

### **5.2 Reduce Antenna Interference**

While using the On-board PCB antenna, in order to have the best Wi-Fi performance, it's recommended to keep a minimum 15mm distance between the antenna part and the other metal pieces.

User's own PCBA design is recommended NOT to pass any wire, NOT do copper pour under the region of the module's antenna, to avoid interferences.



## 6. Packaging Information And Production Guide

### 6.1 Mechanical Dimensions

Figure 6.1. Top view of the module

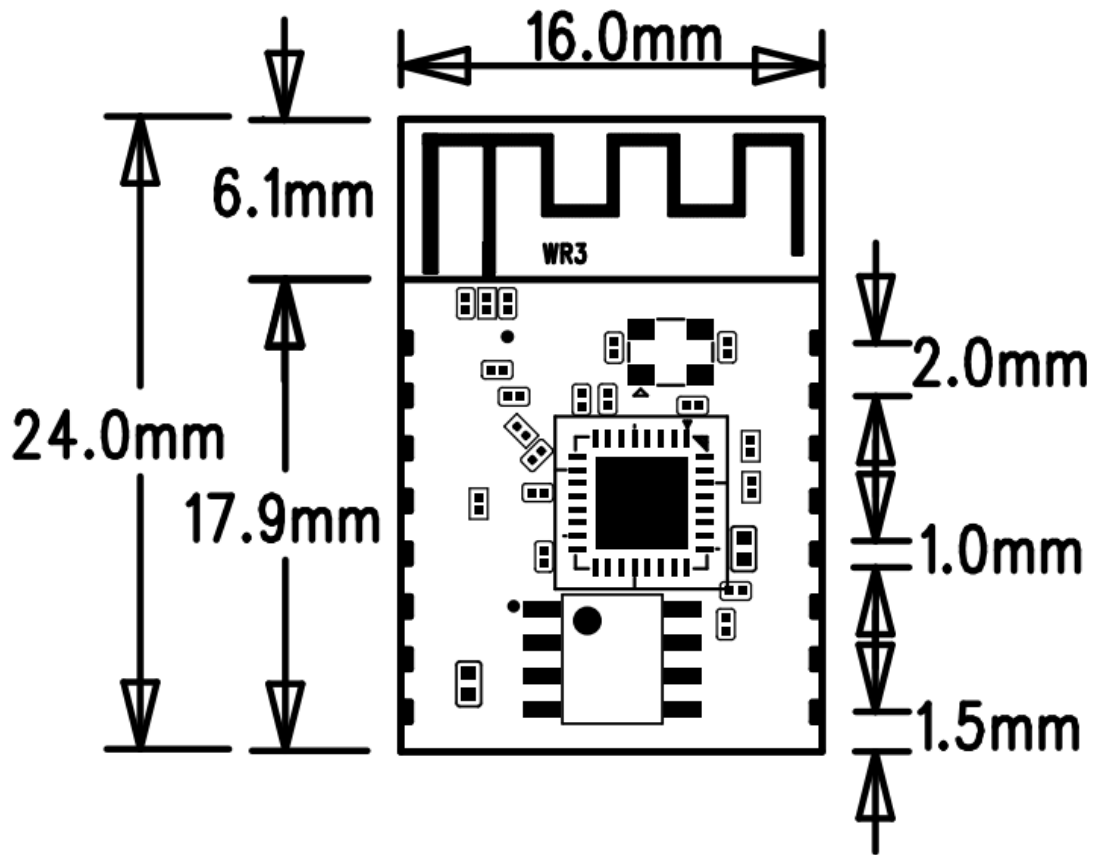
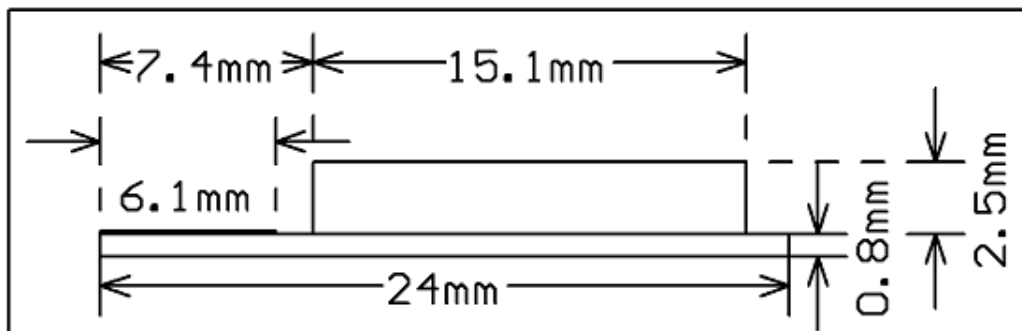

Figure 6.2. The module's mechanical view



### 6.2 PCB Recommended Package

Figure 6.3. PCB schematic Drawing

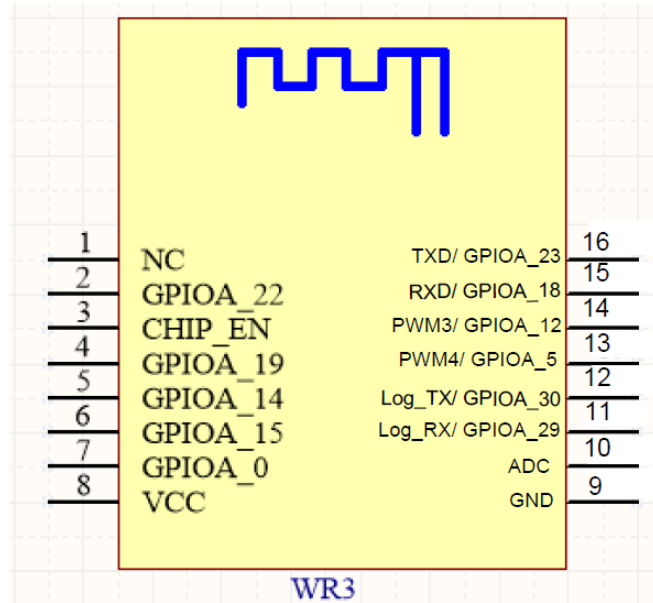
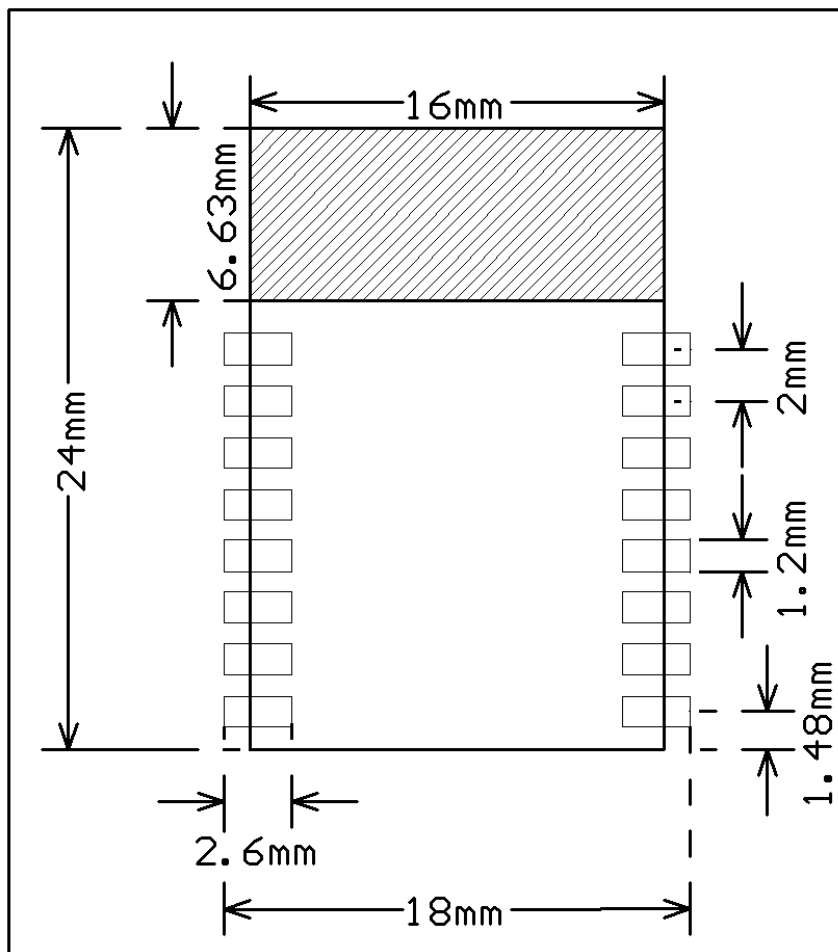

Figure 6.3. PCB footprint



### 6.3 Production Guide

- ✧ The storage for the delivered module should meet the following condition:

1. The anti-moisture bag should be kept in the environment with temperature  $< 30^{\circ}\text{C}$  and humidity  $< 85\% \text{ RH}$ .

2. The expiration date is 6 months since the dry packaging products was sealed.

✧ Cautions:

1. All the operators should wear electrostatic ring in the whole process of production.

2. While operating, water and dirt should not have any contact with the modules.

## 6.4 Recommended furnace temperature curve

Figure 6.4. PCB Package Drawing Recommended furnace temperature curve

Refer to IPC/JEDEC standard ; Peak Temperature :  $< 250^{\circ}\text{C}$  ; Number of Times :  $\leq 2$  times ;

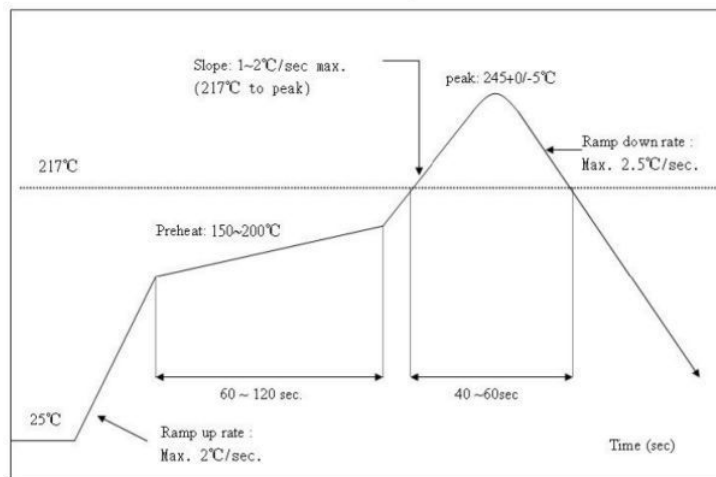

### FCC Statement

Any Changes or modifications not expressly approved by the party responsible for compliance could void the user's authority to operate the equipment.

This device complies with part 15 of the FCC Rules. Operation is subject to the following two conditions:

- (1) This device may not cause harmful interference, and
- (2) This device must accept any interference received, including interference that may cause undesired operation.

### FCC Radiation Exposure Statement:

This equipment complies with FCC radiation exposure limits set forth for an uncontrolled environment. This equipment should be installed and operated with minimum distance 20cm between the radiator & your body.

### FCC Label Instructions:

The outside of final products that contains this module device must display a label referring to the enclosed module. This exterior label can use wording such as: "Contains Transmitter Module FCC ID:2ANDL-WR3", or "Contains FCC ID:2ANDL-WR3", Any similar wording that expresses the same meaning may be used.