

FCC TEST REPORT

Report No.: ARFR-ESH-P2004211473B-3-A1

Product: Smart Zigbee Gateway

Test Model: THP10-Z

Received: Jul.09, 2020

ISSUED: Jul.29, 2020

Applicant: Hangzhou Tuya Information Technology Co., Ltd

Address: Room701, Building3, More Center, No.87 GuDun Road, Hangzhou,
Zhejiang, China

Issued By: BUREAU VERITAS ADT (Shanghai) Corporation

Lab Location: No. 829, Xinzhuan Road, Shanghai, P.R.China (201612)

This test report consists of 24 pages in total. It may be duplicated completely for legal use with the approval of the applicant. It should not be reproduced except in full, without the written approval of our laboratory. The client should not use it to claim product certification, approval, or endorsement by A2LA, CNAS, or any government agency. The test results in the report only apply to the tested item. The test results in this report are traceable to the national or international standards.





**BUREAU
VERITAS**

Contents

1. TEST PROGRAM.....	3
2. Summary of Test Procedure and Test Results	4
3. Test Configuration of Equipment under Test	5
3.1 Manufacturer information.....	5
3.2 Feature of Equipment under Test.....	5
3.3 Description of support units	5
3.4 Measurement Uncertainty	6
4 Test of Conducted Emission	7
4.1 Test Limit	7
4.2 Test Procedures	8
4.3 Typical Test Setup	8
4.4 Measurement Equipment	9
4.5 Test Result and Data	10
4.6 Test Photographs	14
5 Test of Radiated Emission	15
5.1 Test Limit	15
5.2 Test Procedures	16
5.3 Typical Test Setup	16
5.4 Measurement Equipment	17
5.5 Test Result and Data (30MHz ~ 1GHz).....	18
5.6 Test Result and Data (1GHz ~ 18GHz).....	20
5.7 Test Photographs (30MHz ~ 1000MHz).....	22
5.8 Test Photographs (1000MHz ~ 18000MHz).....	23
6 Photographs of EUT	24

1. TEST PROGRAM

PRODUCT: Smart Zigbee Gateway
TEST MODEL: THP10-Z
APPLICANT: Hangzhou Tuya Information Technology Co., Ltd
TESTED: Jul.09 to Jul.29, 2020
STANDARDS: 47 CFR FCC Part15, Subpart B, Class B
ANSI C63.4:2014

We, BUREAU VERITAS ADT (Shanghai) Corporation, declare that the equipment above has been tested and found compliance with the requirement limits of applicable standards. The test record, data evaluation and Equipment Under Test (EUT) configurations represented herein are true and accurate under the standards herein specified.

PREPARED BY : Scott Xu , **DATE:** Jul.29, 2020
Scott Xu
Project Engineer

APPROVED BY : Daniel Sun , **DATE:** Jul.29, 2020
Daniel Sun
EMC Lab Manager





**BUREAU
VERITAS**

2. Summary of Test Procedure and Test Results

EMISSION (47 CFR FCC Part15, Subpart B)		
Test Item	Normative References	Test Result
Conducted Emission	47 CFR FCC Part15, Subpart B 15.107	Meets the Class B requirements
Radiated Emission	47 CFR FCC Part15, Subpart B 15.109	Meets the Class B requirements



**BUREAU
VERITAS**

3. Test Configuration of Equipment under Test

3.1 Manufacturer information

Manufacturer : Hangzhou Tuya Information Technology Co., Ltd

Address : Room701, Building3, More Center, No.87 GuDun Road, Hangzhou, Zhejiang,
China

3.2 Feature of Equipment under Test

Product Name:	Smart Zigbee Gateway
Test Model:	THP10-Z
EUT Power Rating:	5VDC/1A with adaptor 100-240Vac~, 50/60Hz

Note: 1. Please refer to user manual.

Special Comment: This report is updated report based on history report ARFR-ESH-P2004211473B-3 for adding new adaptor KA06E-0501000US. So we choose the new adaptor for full tests.

3.3 Description of support units

NO.	PRODUCT	BRAND	MODEL NO.
1	Adaptor	--	KA06E-0501000US
2	Mobile Phone	Vivo	--
3	Network Cable	--	--

3.4 Measurement Uncertainty

Where relevant, the following measurement uncertainty levels have been estimated for tests performed on the EUT:

This listed uncertainties are the worst case uncertainty for the entire range of measurement. Please note that the uncertainty values are provided for informational purposes only and are not used in determining the PASS/FAIL results.

Measurement		Value
Conducted emissions		2.55 dB
Radiated emissions	30 MHz ~ 1GHz	3.22 dB
	Above 1GHz	2.89 dB

4 Test of Conducted Emission

4.1 Test Limit

TEST STANDARD:

CFR 47 FCC Part 15, Subpart B (Section: 15.107)

FREQUENCY (MHz)	Class A (dB μ V)		Class B (dB μ V)	
	Quasi-peak	Average	Quasi-peak	Average
0.15 - 0.5	79	66	66 - 56	56 - 46
0.50 - 5.0	73	60	56	46
5.0 - 30.0	73	60	60	50

- NOTES:**
1. The lower limit shall apply at the transition frequencies.
 2. The limit decreases in line with the logarithm of the frequency in the range of 0.15 to 0.50MHz.
 3. All emanations from a class A/B digital device or system, including any network of conductors and apparatus connected thereto, shall not exceed the level of field strengths specified above.



**BUREAU
VERITAS**

4.4 Measurement Equipment

DESCRIPTION & MANUFACTURER	MODEL NO.	SERIAL NO.	CALIBRATED UNTIL
Test Receiver ROHDE & SCHWARZ	ESCS30	E1R1001	Mar.11, 2021
LISN ROHDE & SCHWARZ	ENV216	E1L1011	Mar.11, 2021
Software ADT	ADT_Cond_V7.3.0	N/A	N/A



BUREAU
VERITAS

4.5 Test Result and Data

Conducted Emission Test Data

120Vac/60Hz

Phase : LINE

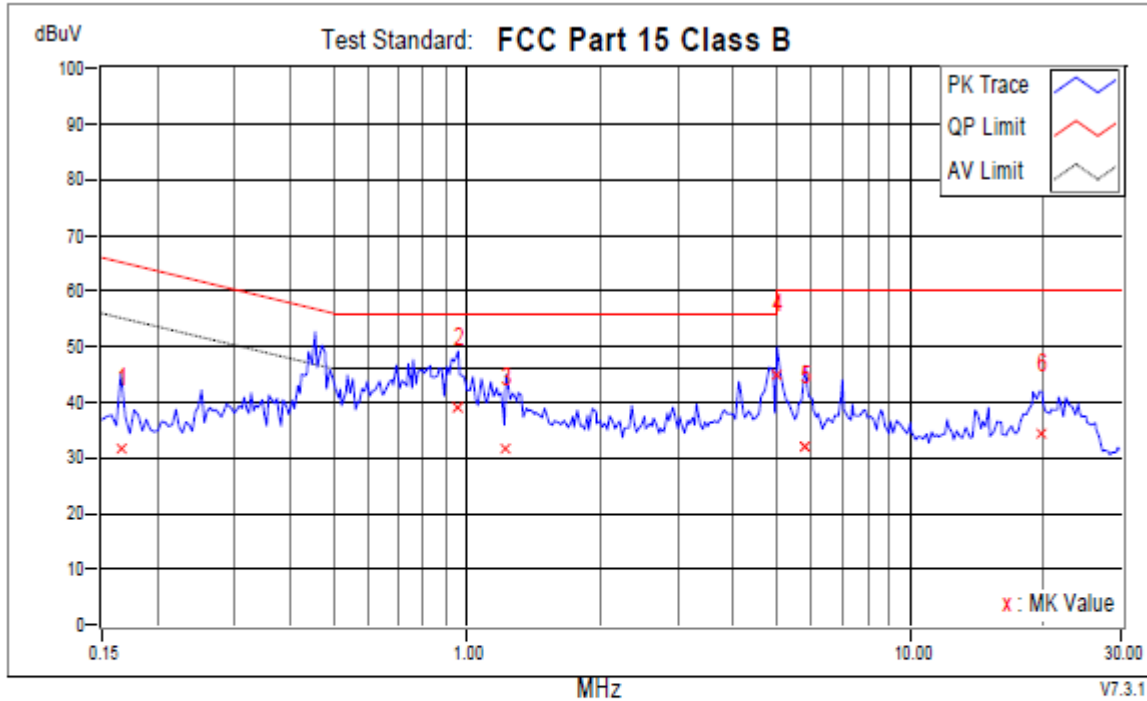

No.	Frequency	Corr. Factor	Reading dBuV		Emission dBuV		Limit dBuV		Margins dB		Notes
	MHz		QP	AV	QP	AV	QP	AV	QP	AV	
1	0.16564	9.85	21.80	11.80	31.65	21.65	65.18	55.18	-33.53	-33.53	
2	0.95546	9.59	29.55	16.49	39.14	26.08	56.00	46.00	-16.86	-19.92	
3	1.22678	9.63	21.84	10.01	31.47	19.64	56.00	46.00	-24.53	-26.36	
+4	5.01166	10.05	34.78	23.53	44.83	33.58	60.00	50.00	-15.17	-16.42	
5	5.79366	10.10	21.98	12.35	32.08	22.45	60.00	50.00	-27.92	-27.55	
6	19.87666	10.26	24.27	14.58	34.53	24.84	60.00	50.00	-25.47	-25.16	

REMARKS:

1. Q.P. and AV. are abbreviations of quasi-peak and average individually.
2. The emission levels of other frequencies were very low against the limit.
3. Margin value = Emission level - Limit value
4. Correction factor = Insertion loss + Cable loss
5. Emission Level = Correction Factor + Reading Value.



BUREAU
VERITAS

Phase : NEUTRAL

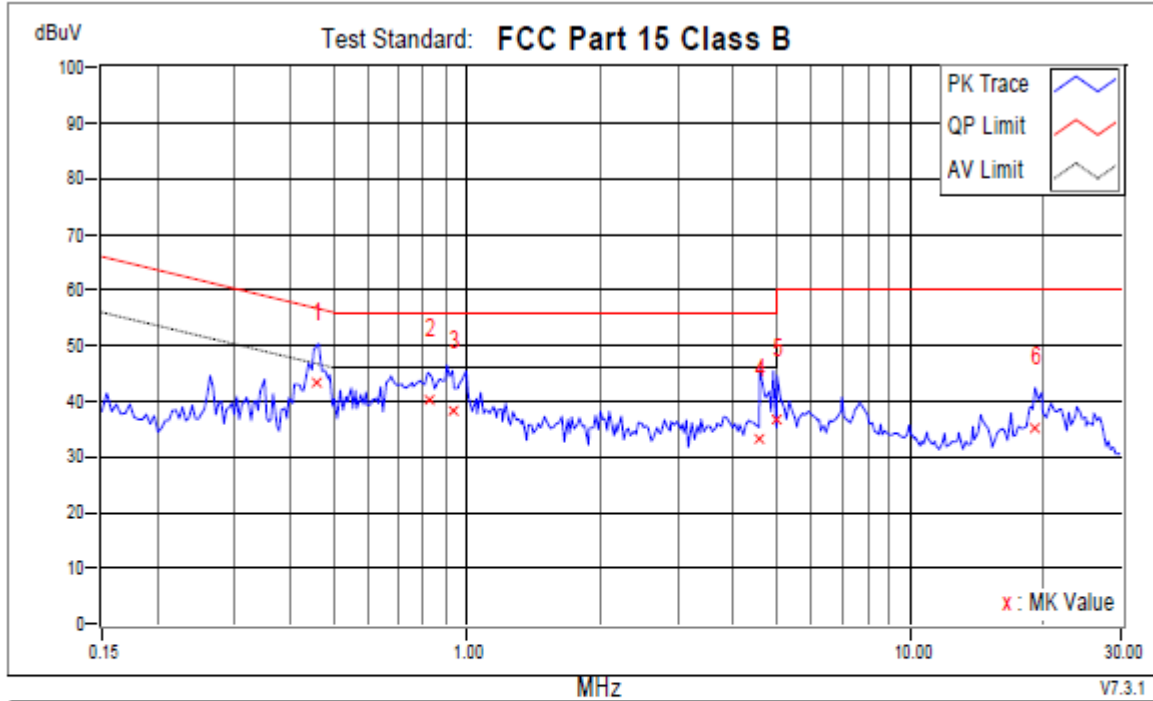

No.	Frequency MHz	Corr. Factor dB	Reading dBuV		Emission dBuV		Limit dBuV		Margins dB		Notes
			QP	AV	QP	AV	QP	AV	QP	AV	
+1	0.45889	9.72	33.77	25.32	43.49	35.04	56.71	46.71	-13.22	-11.67	
2	0.81861	9.59	30.52	23.11	40.11	32.70	56.00	46.00	-15.89	-13.30	
3	0.92809	9.59	28.55	20.30	38.14	29.89	56.00	46.00	-17.86	-16.11	
4	4.57765	10.01	23.19	16.73	33.20	26.74	56.00	46.00	-22.80	-19.26	
5	5.00000	10.05	26.55	19.93	36.60	29.98	56.00	46.00	-19.40	-16.02	
6	19.15722	10.27	25.04	15.04	35.31	25.31	60.00	50.00	-24.69	-24.69	

REMARKS:

1. Q.P. and AV. are abbreviations of quasi-peak and average individually.
2. The emission levels of other frequencies were very low against the limit.
3. Margin value = Emission level - Limit value
4. Correction factor = Insertion loss + Cable loss
5. Emission Level = Correction Factor + Reading Value.



**BUREAU
VERITAS**

240Vac/50Hz

Phase: LINE

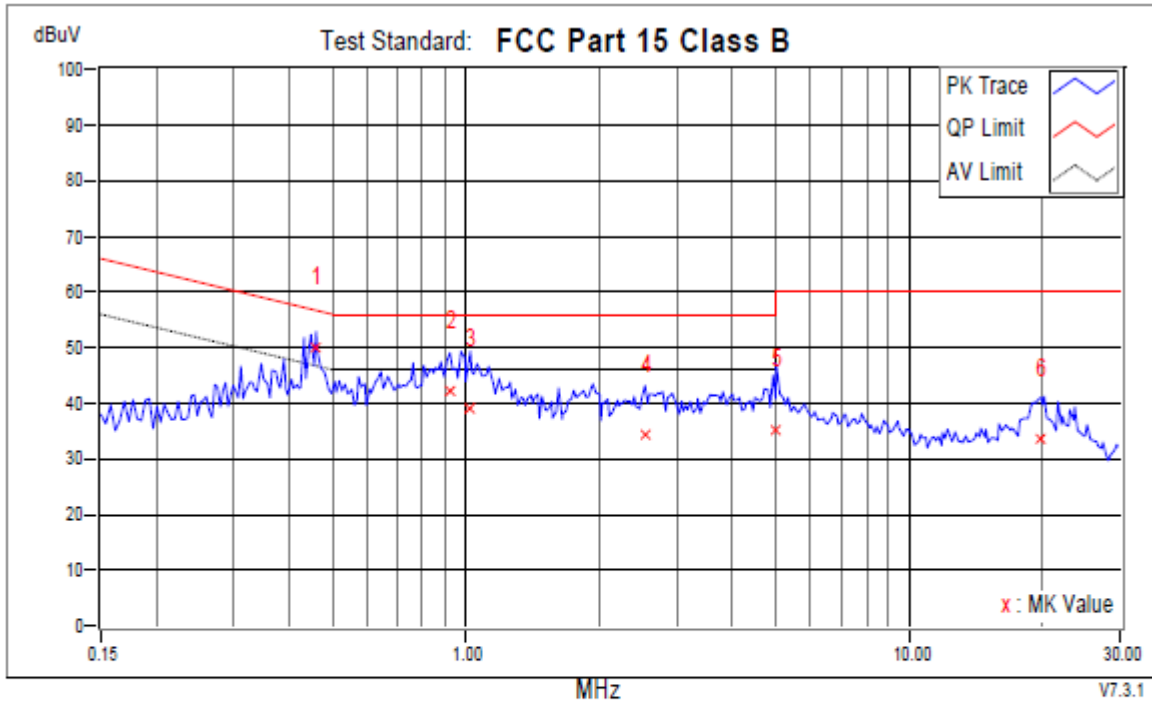

No.	Frequency	Corr. Factor	Reading dBuV		Emission dBuV		Limit dBuV		Margins dB		Notes
	MHz		QP	AV	QP	AV	QP	AV	QP	AV	
+1	0.45889	9.72	40.18	25.31	49.90	35.03	56.71	46.71	-6.81	-11.68	
2	0.92027	9.59	32.62	17.89	42.21	27.48	56.00	46.00	-13.79	-18.52	
3	1.02346	9.59	29.29	15.68	38.88	25.27	56.00	46.00	-17.12	-20.73	
4	2.53663	9.82	24.72	12.46	34.54	22.28	56.00	46.00	-21.46	-23.72	
5	5.00000	10.05	25.00	13.91	35.05	23.96	56.00	46.00	-20.95	-22.04	
6	19.86102	10.26	23.35	13.99	33.61	24.25	60.00	50.00	-26.39	-25.75	

REMARKS:

1. Q.P. and AV. are abbreviations of quasi-peak and average individually.
2. The emission levels of other frequencies were very low against the limit.
3. Margin value = Emission level - Limit value
4. Correction factor = Insertion loss + Cable loss
5. Emission Level = Correction Factor + Reading Value.

Phase: NEUTRAL

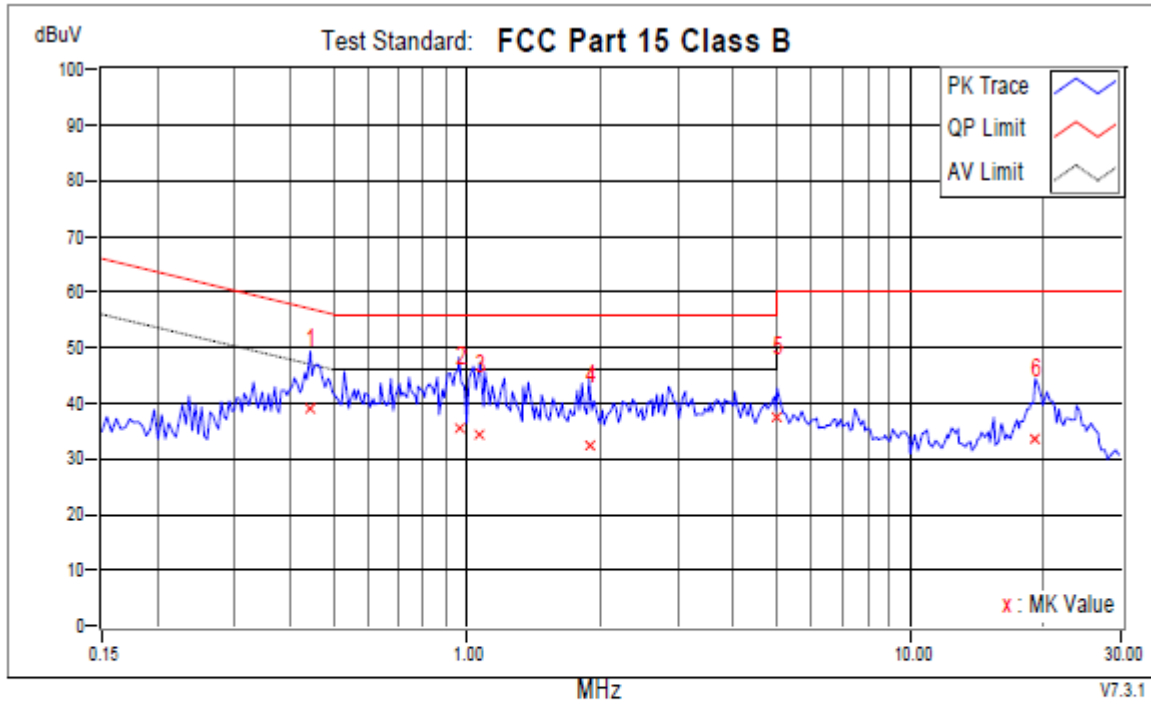

No.	Frequency MHz	Corr. Factor dB	Reading dBuV		Emission dBuV		Limit dBuV		Margins dB		Notes
			QP	AV	QP	AV	QP	AV	QP	AV	
+1	0.44325	9.85	29.27	19.28	39.12	29.13	57.00	47.00	-17.88	-17.87	
2	0.95937	9.89	25.77	13.37	35.66	23.26	56.00	46.00	-20.34	-22.74	
3	1.07038	9.89	24.57	13.06	34.46	22.95	56.00	46.00	-21.54	-23.05	
4	1.88757	9.93	22.39	8.30	32.32	18.23	56.00	46.00	-23.68	-27.77	
5	5.01166	9.71	27.71	18.08	37.42	27.79	60.00	50.00	-22.58	-22.21	
6	19.17286	10.39	23.25	12.37	33.64	22.76	60.00	50.00	-26.36	-27.24	

REMARKS:

1. Q.P. and AV. are abbreviations of quasi-peak and average individually.
2. The emission levels of other frequencies were very low against the limit.
3. Margin value = Emission level - Limit value
4. Correction factor = Insertion loss + Cable loss
5. Emission Level = Correction Factor + Reading Value.



**BUREAU
VERITAS**

4.6 Test Photographs



5 Test of Radiated Emission

5.1 Test Limit

TEST STANDARD:

CFR 47 FCC Part 15, Subpart B (Section: 15.109)

FOR FREQUENCY BELOW 1000 MHz

FREQUENCY (MHz)	Class A (at 10m)		Class B (at 3m)	
	$\mu\text{V/m}$	$\text{dB}\mu\text{V/m}$	$\mu\text{V/m}$	$\text{dB}\mu\text{V/m}$
30 – 88	90	39.1	100	40.0
88 – 216	150	43.5	150	43.5
216 – 960	210	46.4	200	46.0
960 – 1000	300	49.5	500	54.0

LIMIT OF RADIATED EMISSION OF FCC PART 15, SUBPART B FOR FREQUENCY ABOVE 1000 MHz

FREQUENCY (MHz)	Class A ($\text{dB}\mu\text{V/m}$) (at 3m)		Class B ($\text{dB}\mu\text{V/m}$) (at 3m)	
	PEAK	AVERAGE	PEAK	AVERAGE
Above 1000	80.0	60.0	74.0	54.0

- Note:**
1. The lower limit shall apply at the transition frequencies.
 2. Emission level ($\text{dB}\mu\text{V/m}$) = $20 \log$ Emission level ($\mu\text{V/m}$).
 3. All emanation from a class A/B digital device or system, including any network of conductors and apparatus connected thereto, shall not exceed the level of field strengths specified above.

5.2 Test Procedures

1. The EUT was placed on a rotatable table top 0.8 meter above ground.
2. The EUT was set 3/10 meters from the interference receiving antenna which was mounted on the top of a variable height antenna tower.
3. The table was rotated 360 degrees to determine the position of the highest radiation.
4. The antenna is a half wave dipole and its height is varied between one meter and four meters above ground to find the maximum value of the field strength both horizontal polarization and vertical polarization of the antenna are set to make the measurement.
5. For each suspected emission the EUT was arranged to its worst case and then tune the antenna tower (from 1 M to 4 M) and turn table (from 0 degree to 360 degrees) to find the maximum reading.
6. Set the test-receiver system to Peak Detect Function and specified bandwidth with Maximum Hold Mode.
7. If the emission level of the EUT in peak mode was 3 dB lower than the limit specified, then testing will be stopped and peak values of EUT will be reported, otherwise, the emissions which do not have 3 dB margin will be repeated one by one using the quasi-peak method and reported.

5.3 Typical Test Setup

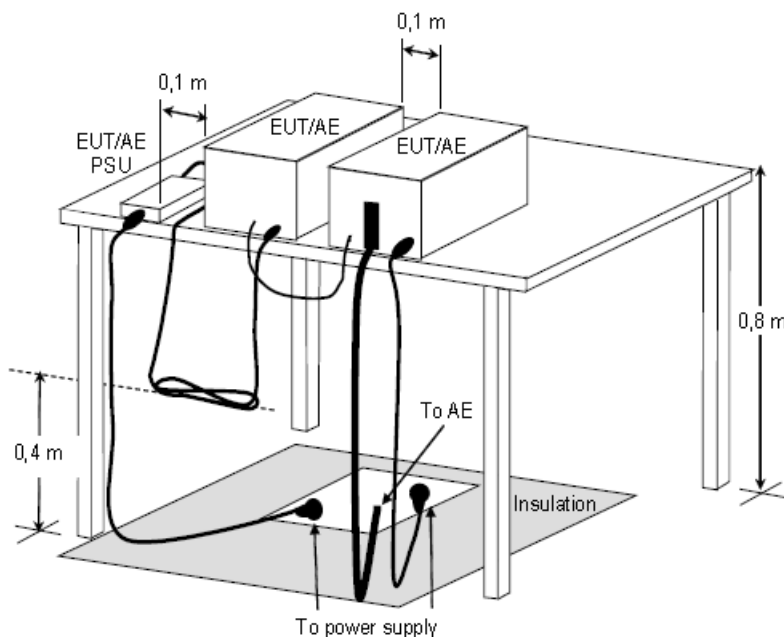

**Figure D.8 – Example measurement arrangement for table-top EUT
(Radiated emission measurement)**



**BUREAU
VERITAS**

5.4 Measurement Equipment

DESCRIPTION & MANUFACTURER	MODEL NO.	SERIAL NO.	CALIBRATED UNTIL
EMI Test Spectrum ROHDE & SCHWARZ	ESR7	E1R1005	May.11, 2021
Spectrum Analyzer Keysight	N9030B	E1S1003	Aug.04, 2020
Broad-Band Antenna Schwarzbeck	VULB9168	E1A1012	Jul.28, 2020
Double Riaged Vroadband Horn Antenna Schwarzbeck	BBHA9120D	E1A1017	Jan.25, 2021
Preamplifier Agilent	8447D	E1A2001	Apr.19, 2021
Preamplifier Agilent	EMC051845SE	E1A2009	Jul.05, 2021



5.5 Test Result and Data (30MHz ~ 1GHz)

Position: Horizontal

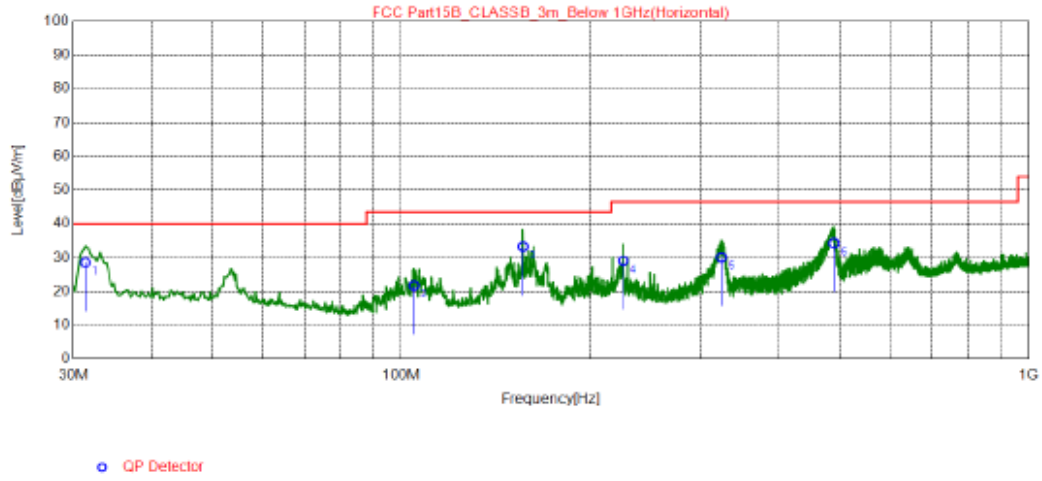

NO.	Freq. [MHz]	QP Reading [dBµV/m]	Factor [dB]	QP Value [dBµV/m]	QP Limit [dBµV/m]	QP Margin [dB]	Height [cm]	Angle [°]	Polarity
1	31.35	39.1	-10.54	28.56	40.00	11.44	200	251	Horizontal
2	104.6	34.53	-12.82	21.71	43.50	21.79	200	279	Horizontal
3	156.2	42.35	-9.07	33.28	43.50	10.22	200	267	Horizontal
4	225.7	40.37	-11.27	29.10	46.50	17.40	200	302	Horizontal
5	323.7	38.78	-8.70	30.08	46.50	16.42	200	120	Horizontal
6	489.1	40	-5.73	34.27	46.50	12.23	200	317	Horizontal

REMARKS:

1. Q.P. is abbreviation of quasi-peak individually.
2. The emission levels of other frequencies were very low against the limit.
3. QP Margin value = QP Limit value – QP value.
4. Factor = Antenna Factor + Amplifier Factor + Cable loss.
5. QP value = Factor + Reading Value.



Position: Vertical

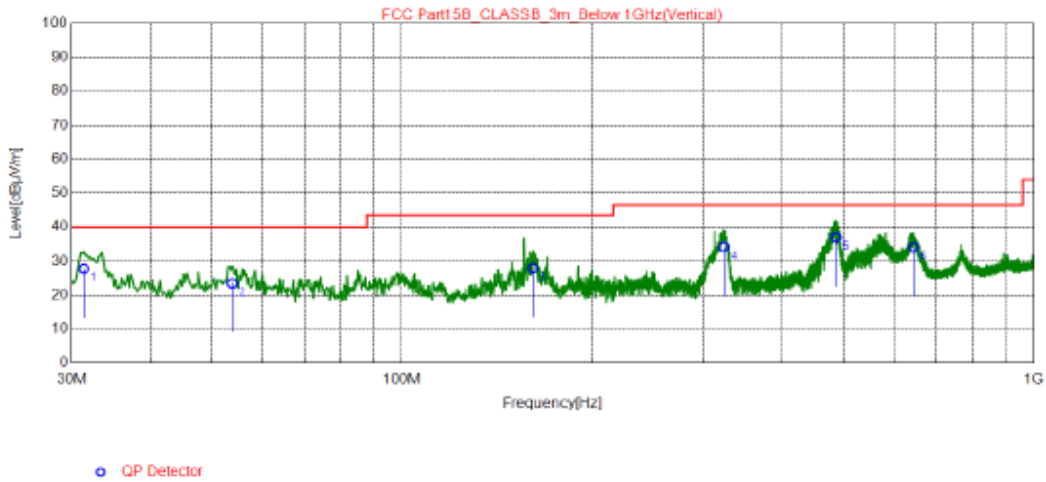

NO.	Freq. [MHz]	QP Reading [dBuV/m]	Factor [dB]	QP Value [dBuV/m]	QP Limit [dBuV/m]	QP Margin [dB]	Height [cm]	Angle [°]	Polarity
1	31.35	38.27	-10.54	27.73	40.00	12.27	100	98	Vertical
2	53.86	33.5	-10.03	23.47	40.00	16.53	100	270	Vertical
3	161.1	36.89	-8.98	27.91	43.50	15.59	100	289	Vertical
4	323.5	42.8	-8.70	34.10	46.50	12.40	100	78	Vertical
5	486.4	42.67	-5.71	36.96	46.50	9.54	100	259	Vertical
6	644.9	37.27	-3.26	34.01	46.50	12.49	100	55	Vertical

REMARKS:

1. Q.P. is abbreviation of quasi-peak individually.
2. The emission levels of other frequencies were very low against the limit.
3. QP Margin value = QP Limit value – QP value
4. Factor = Antenna Factor + Amplifier Factor + Cable loss
5. QP value = Factor + Reading Value.



5.6 Test Result and Data (1GHz ~ 18GHz)

Position: Horizontal

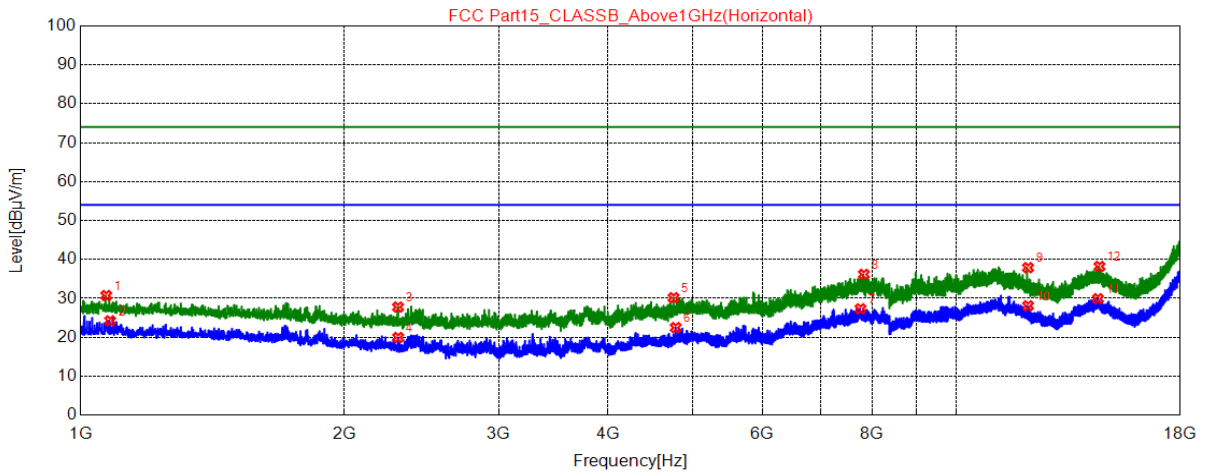

* AV Detector

NO.	Freq. [MHz]	Level [dBµV/m]	Limit [dBµV/m]	Margin [dB]	Height [cm]	Angle [°]	Polarity	Detector
1	1069.7000	30.72	74.00	43.28	155	32	Horizontal	PK
2	1080.7500	24.23	54.00	29.77	155	340	Horizontal	AV
3	2303.0500	27.76	74.00	46.24	155	263	Horizontal	PK
4	2303.9000	19.95	54.00	34.05	155	263	Horizontal	AV
5	4751.9000	30.16	74.00	43.84	155	109	Horizontal	PK
6	4778.2500	22.49	54.00	31.51	155	109	Horizontal	AV
7	7765.1500	27.31	54.00	26.69	155	224	Horizontal	AV
8	7834.8500	36.17	74.00	37.83	155	71	Horizontal	PK
9	12061.0500	37.89	74.00	36.11	155	148	Horizontal	PK
10	12061.9000	28.09	54.00	25.91	155	186	Horizontal	AV
11	14494.6000	29.91	54.00	24.09	155	302	Horizontal	AV
12	14554.1000	38.20	74.00	35.80	155	224	Horizontal	PK

REMARKS:

1. The emission levels of other frequencies were very low against the limit.
2. Margin = Limit –Level



**BUREAU
VERITAS**

Position: Vertical

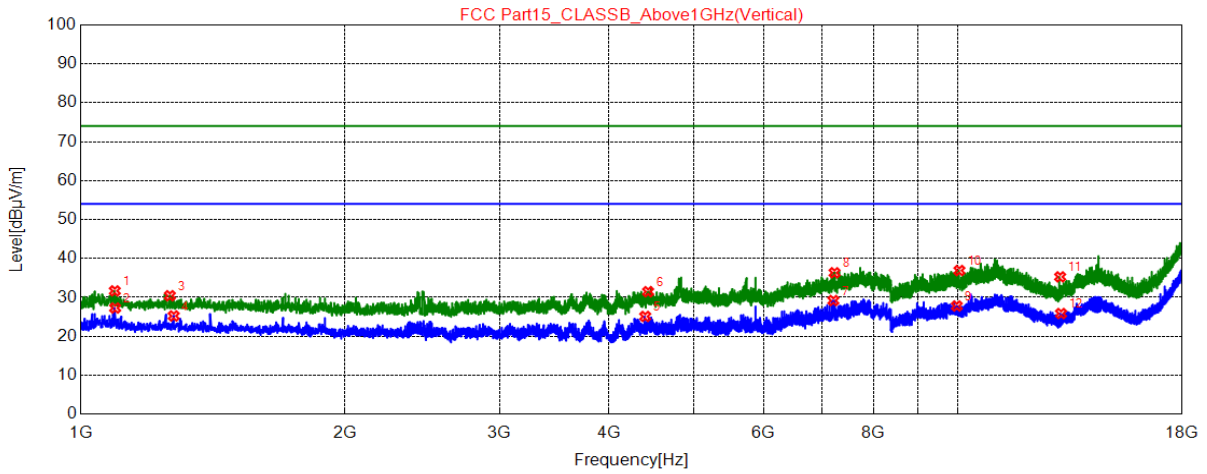

* AV Detector

NO.	Freq. [MHz]	Level [dBµV/m]	Limit [dBµV/m]	Margin [dB]	Height [cm]	Angle [°]	Polarity	Detector
1	1093.5000	31.66	74.00	42.34	155	289	Vertical	PK
2	1094.3500	27.26	54.00	26.74	155	289	Vertical	AV
3	1263.5000	30.42	74.00	43.58	155	212	Vertical	PK
4	1276.2500	25.22	54.00	28.78	155	135	Vertical	AV
5	4398.3000	25.09	54.00	28.91	155	174	Vertical	AV
6	4431.4500	31.46	74.00	42.54	155	327	Vertical	PK
7	7205.8500	29.17	54.00	24.83	155	135	Vertical	AV
8	7227.9500	36.32	74.00	37.68	155	250	Vertical	PK
9	9963.2500	27.78	54.00	26.22	155	212	Vertical	AV
10	10029.5500	36.90	74.00	37.10	155	250	Vertical	PK
11	13065.7500	35.27	74.00	38.73	155	97	Vertical	PK
12	13096.3500	25.84	54.00	28.16	155	20	Vertical	AV

REMARKS:

1. The emission levels of other frequencies were very low against the limit.
2. Margin = Limit –Level



**BUREAU
VERITAS**

5.7 Test Photographs (30MHz ~ 1000MHz)

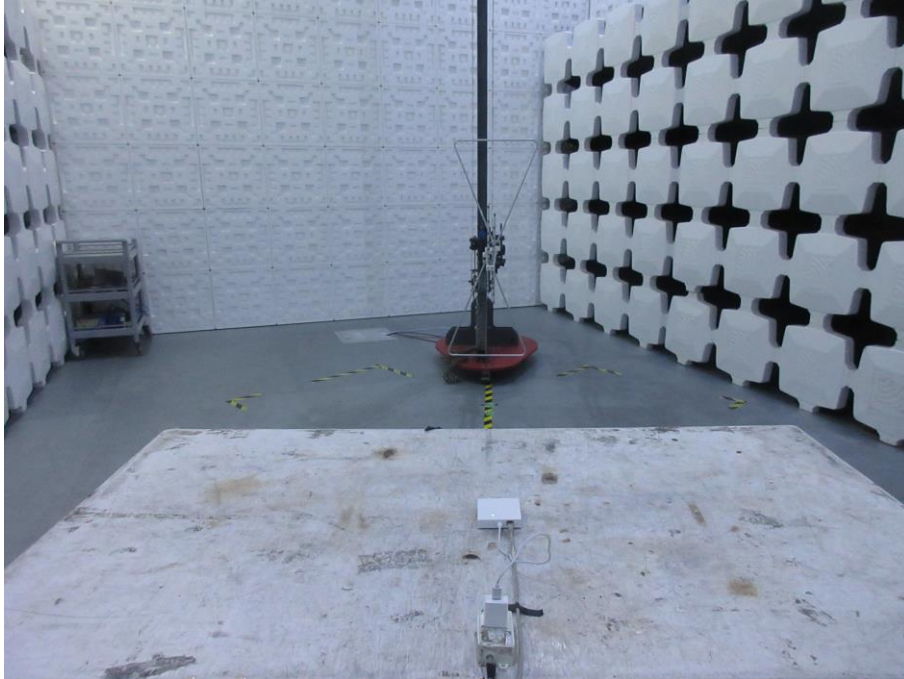



**BUREAU
VERITAS**

5.8 Test Photographs (1000MHz ~ 18000MHz)

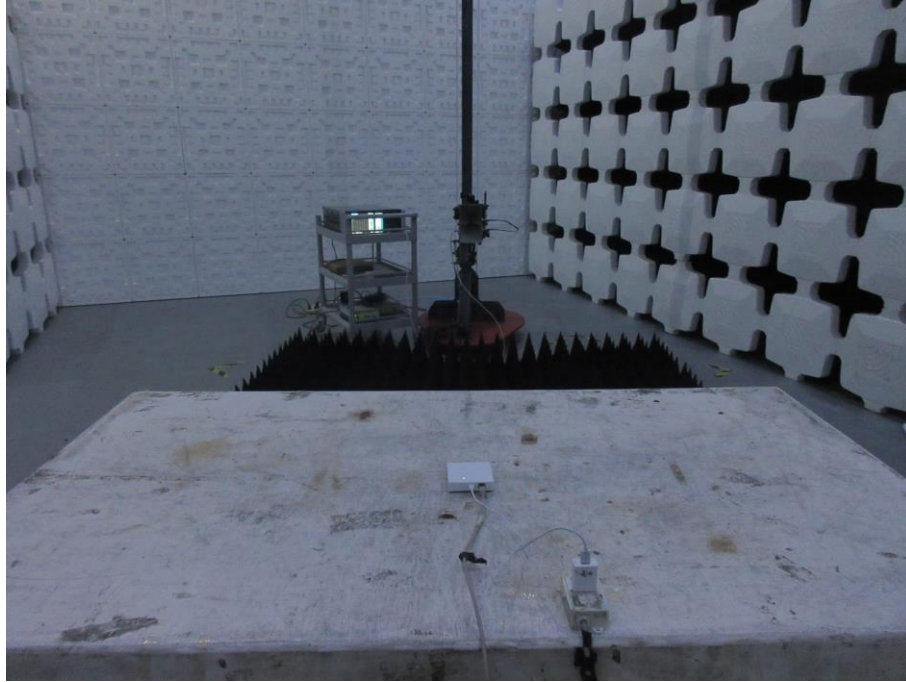

6 Photographs of EUT

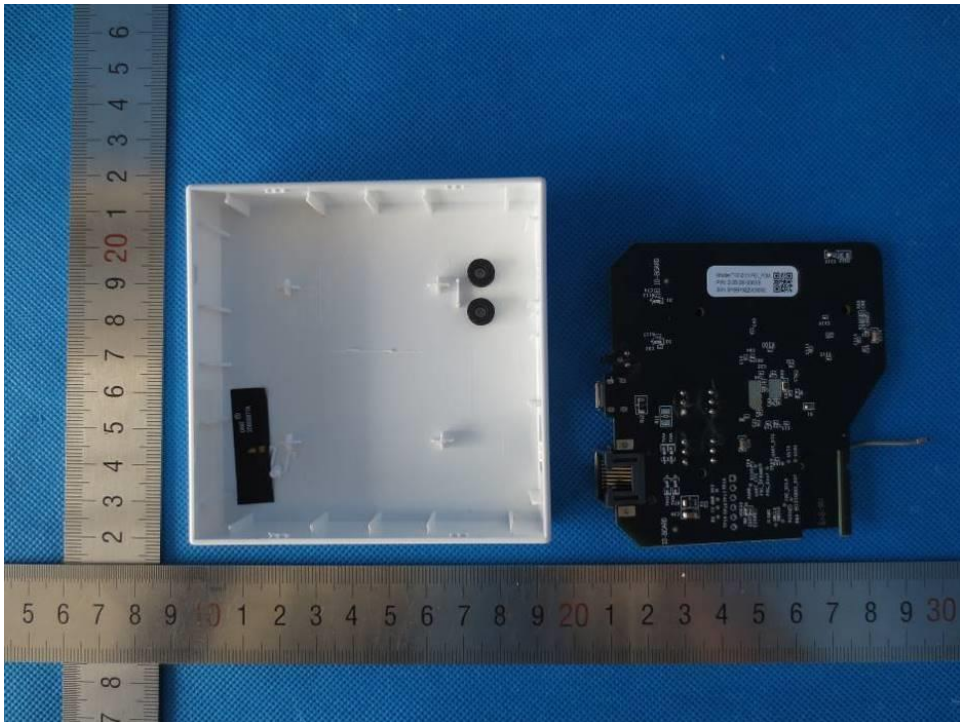
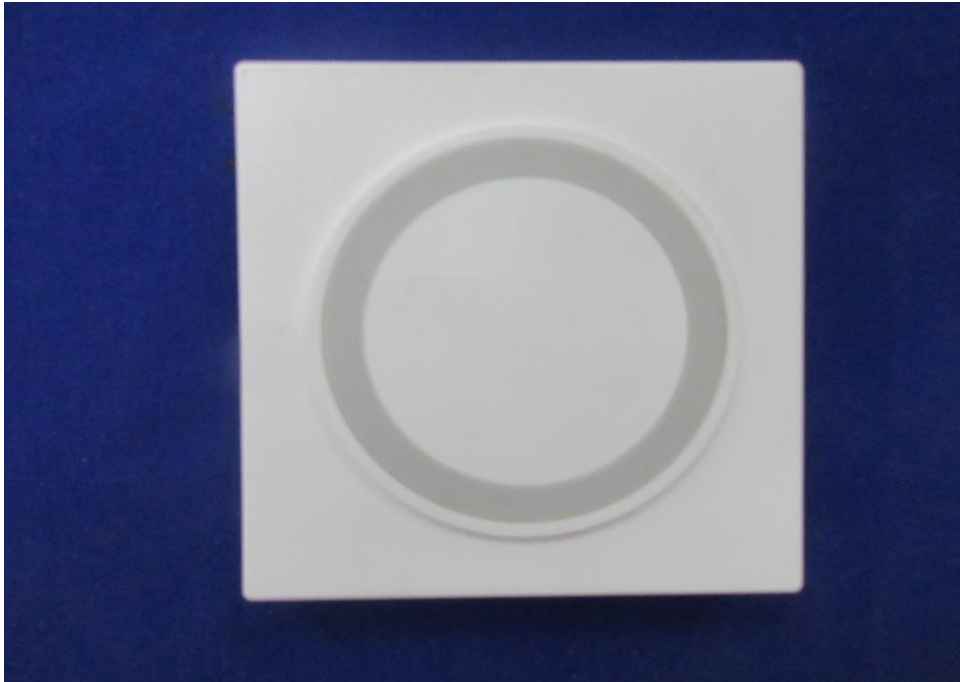

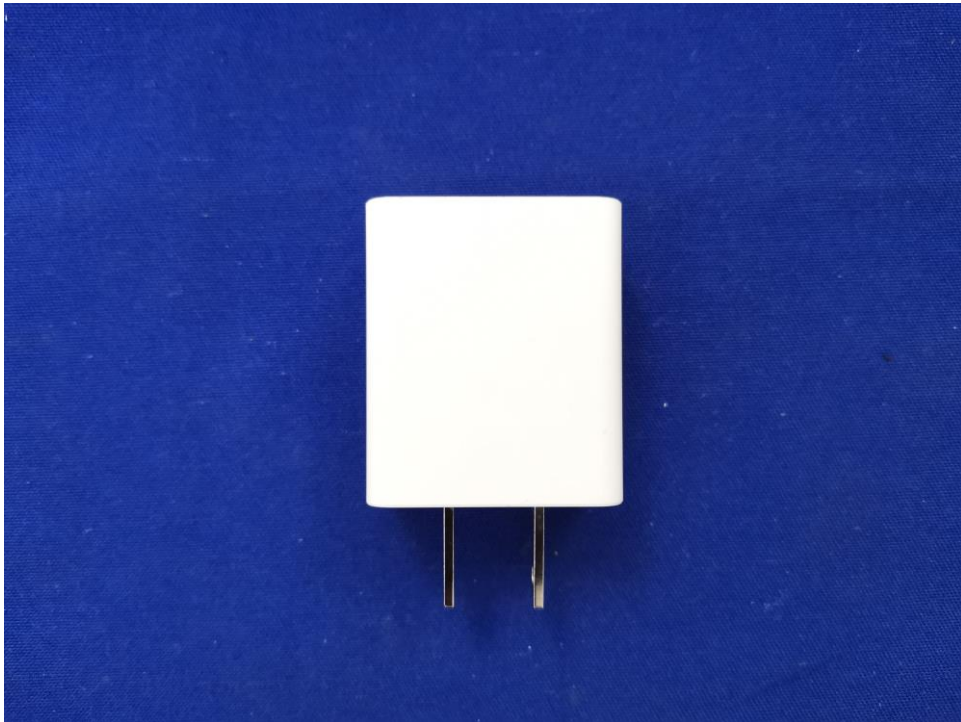
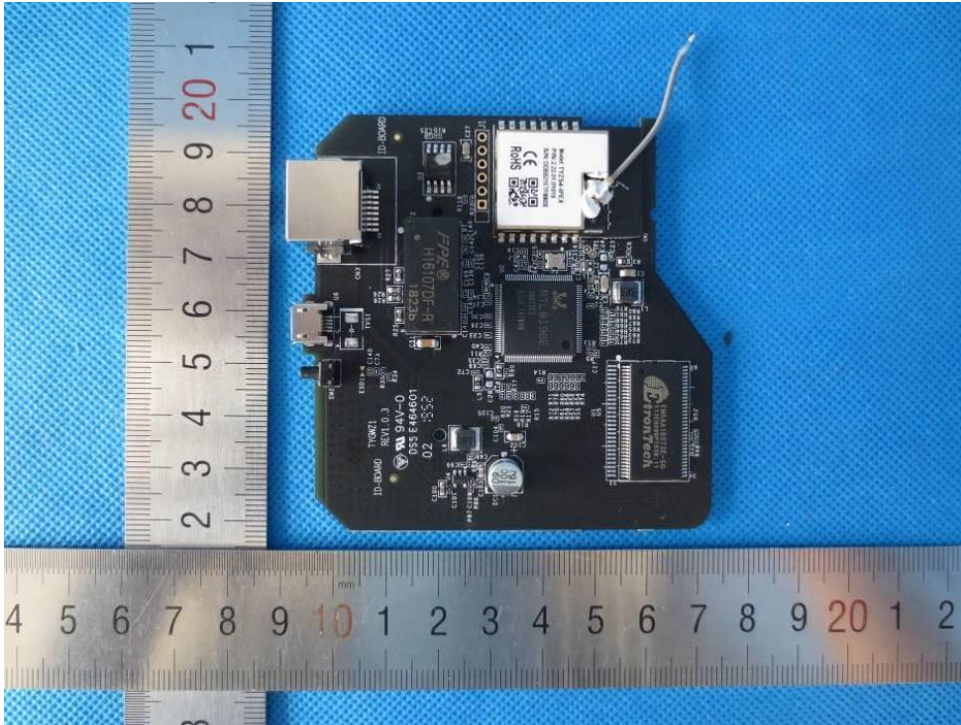



**BUREAU
VERITAS**



--- END ---