

TEST REPORT

of

FCC Part 15 Subpart C

Product: **Function board**
Brand: **CoreStar**
Main Model: **F215U**
Series Model: **N/A**
Model Difference: **N/A**
FCC ID: **2ANCG-F215U**
FCC Rule Part: **§15.247, Cat: DSS**
Reference: **ANSI C63.10: 2013**
KDB 558074 D01 v05r02
Applicant: **CoreStar Co., Ltd.**
Address: **No. 16-3, Shunping 1st St., Xitun Dist., Taichung City, 40754, Taiwan**

Test Performed by:



International Standards Laboratory Corp. LT Lab.

TEL: +886-3-263-8888 FAX: +886-3-263-8899

No. 120, Lane 180, Hsin Ho Rd., Lung-Tan Dist., Tao Yuan City 325, Taiwan

Report No.: **ISL-23LR0029FCDSS**

Issue Date : **March 31, 2023**



FCC Registration Number: 487532

Test results given in this report apply only to the specific sample(s) tested and are traceable to national or international standard through calibration of the equipment and evaluating measurement uncertainty herein. The uncertainty of the measurement does not include in consideration of the test result unless the customer required the determination of uncertainty via the agreement, regulation or standard document specification. This test report shall not be reproduced except in full, without the written approval of International Standards Laboratory Corp.

VERIFICATION OF COMPLIANCE

Applicant: CoreStar Co., Ltd.
Equipment Under Test: Function board
Brand: CoreStar
Main Model: F215U
Series Model: N/A
Model Difference: N/A
FCC ID: 2ANCG-F215U
Date of Test: February 16, 2023 ~ March 31, 2023
Date of EUT Received: February 16, 2023
Test Frim TW0997

APPLICABLE STANDARDS	
STANDARD	TEST RESULT
FCC Part 15.247	Complied

We hereby certify that:
 All the tests in this report have been performed and recorded in accordance with the standards de-scribed above and performed by an independent electromagnetic compatibility consultant, International Standards Laboratory Corp.
 The test results contained in this report accurately represent the measurements of the characteristics and the energy generated by sample equipment under test at the time of the test. The sample equipment tested as described in this report is in compliance with the limits of above standards.

Test By: Barry Lee **Date:** March 31, 2023
 Barry Lee / Senior Engineer

Prepared By: Gigi Yeh **Date:** March 31, 2023
 Gigi Yeh / Senior Engineer

Approved By: Jerry Liu **Date:** March 31, 2023
 Jerry Liu / Assistant Manager

Version

Version No.	Date	Description
00	March 31, 2023	Initial creation of document

TABLE OF CONTENTS

1. General.....	6
1.1 DESCRIPTION OF EUT	6
1.2 SPECIAL ACCESSORIES	8
1.3 EQUIPMENT MODIFICATIONS	8
2. System Test Configuration.....	9
2.1 EUT CONFIGURATION.....	9
2.2 EUT EXERCISE	9
2.3 TEST PROCEDURE.....	9
2.4 CONFIGURATION OF TESTED SYSTEM.....	10
3. Summary of Test Results.....	12
4. Description of Test Modes.....	12
5. AC Line Conduced Emission Test.....	13
5.1 STANDARD APPLICABLE	13
5.2 MEASUREMENT PROCEDURE.....	13
5.3 MEASUREMENT RESULT.....	14
6. Peak Output Power Measurement	18
6.1 STANDARD APPLICABLE	18
6.2 MEASUREMENT PROCEDURE.....	18
6.3 MEASUREMENT RESULT.....	19
7. Radiated Spurious Emission Test.....	20
7.1 STANDARD APPLICABLE	20
7.2 MEASUREMENT PROCEDURE.....	20
7.3 FIELD STRENGTH CALCULATION	21
7.4 MEASUREMENT RESULT.....	22
8. 100kHz Bandwidth of Band Edges Measurement	76
8.1 STANDARD APPLICABLE	76
8.2 MEASUREMENT PROCEDURE.....	76
8.3 FIELD STRENGTH CALCULATION	76
8.4 MEASUREMENT RESULT.....	77
9. 20dB Bandwidth.....	101
9.1 STANDARD APPLICABLE	101
9.2 MEASUREMENT PROCEDURE.....	101
9.3 MEASUREMENT RESULT.....	101
10. Frequency Separation.....	107
10.1 STANDARD APPLICABLE	107
10.2 MEASUREMENT PROCEDURE.....	107
10.3 MEASUREMENT RESULT.....	108
11. Number of Hopping Frequency	110
11.1 STANDARD APPLICABLE	110
11.2 MEASUREMENT PROCEDURE.....	110
11.3 MEASUREMENT RESULT.....	111



- 12. Time of Occupancy (Dwell Time) 112**
 - 12.1 STANDARD APPLICABLE112
 - 12.2 MEASUREMENT PROCEDURE.....112
 - 12.3 MEASUREMENT RESULT.....112
- 13. Appendix 118**
 - 13.1 APPENDIX A: EQUIPMENT LIST118
 - 13.2 APPENDIX B: UNCERTAINTY OF MEASUREMENT.....120
 - 13.3 APPENDIX C: TEST SETUP121
 - 13.4 APPENDIX D: PHOTOGRAPHS OF SETUP124
 - 13.5 APPENDIX E: PHOTOGRAPHS OF EUT130

1. General

1.1 Description of EUT

General Information	
Product Name:	Function board
Brand Name:	CoreStar
Model Name:	F215U
Model Difference:	N/A
Temperature Range	-40°C to 85°C
Power Supply:	12V DC
Bluetooth Information	
BT Modular:	MT6631
Bluetooth Version:	V2.1 + EDR
Frequency Range:	2402 – 2480MHz
Max Output Power:	4.84dBm
Channel number:	79 channels
Modulation type:	FHSS
PMN (Product Marketing Name)	F215U
HVIN (Hardware Version Identification Number)	RC-F215U
FVIN (Firmware Version Identification Number)	4.14.141
Product SW/HW version	SW_V1.0/HW_V1.3
Test SW Version:	F215U Q0 V4.69 PBJ-V38.8839.lcm.10.1_debug
RFpower setting:	802.11b :19.5 802.11g:17.5 802.11 HT20:17.5 802.11 HT40:16.5 802.11a:16 802.11HT20 (5G):16 802.11HT40(5G::16 802.11VHT20:16 802.11VHT40:16 802.11VHT80:16

	Antenna Type	Brand	Model	Peak Gain (dBi)	Frequency Range	Connector Type
1	PIFA	CoreStar	XBY00216	2400~2500MHz :0.69	2.4GHz	i-pex
2	PIFA	CoreStar	XBY00216	5150~5250MHz :1.24	5GHz	i-pex

1.2 Special Accessories

Not available for this EUT intended for grant.

1.3 Equipment Modifications

Not available for this EUT intended for grant.

2. System Test Configuration

2.1 EUT Configuration

The EUT configuration for testing is installed on RF field strength measurement to meet the Commissions requirement and operating in a manner which intends to maximize its emission characteristics in a continuous normal application.

2.2 EUT Exercise

The EUT (Transmitter) was operated in the engineering mode to fix the Tx frequency that was for the purpose of the measurements.

2.3 Test Procedure

2.3.1 AC Line Conducted Emissions

The EUT is placed on a turn table which is 0.8 m above ground plane. According to ANSI C63.10 and RSS-Gen. AC Line Conducted emissions from the EUT measured in the frequency range between 0.15 MHz and 30MHz using CISPR 16-1-1 Quasi-Peak and Average detector mode.

2.3.2 Radiated Emissions

The EUT is placed on a turn table which is 0.8 m/1.5m (Frequency above 1GHz) above ground plane. The turn table shall rotate 360 degrees to determine the position of maximum emission level. EUT is set 3m away from the receiving antenna which varied from 1m to 4m to find out the highest emission. And also, each emission was to be maximized by changing the polarization of receiving antenna both horizontal and vertical. In order to find out the max. emission, the relative positions of this hand-held transmitter (EUT) was rotated through three orthogonal axes according to ANSI C63.10.

2.4 Configuration of Tested System

Configuration of Tested System (Fixed channel)

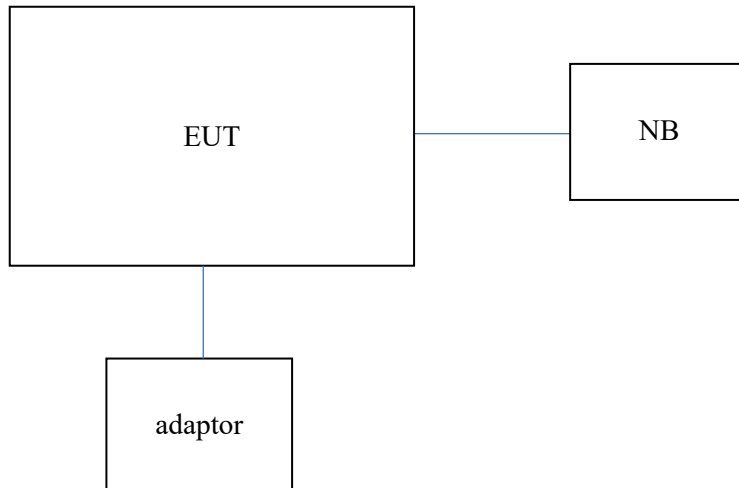

Equipment Used in Tested System

Item	Equipment	Mfr/Brand	Model/ Type No.	Series No.	Data Cable	Power Cord
1	NB	HP	440-G1	NA	NA	180cm
2	adaptor	CoreStar	SW24-120U	NA	NA	150cm

Conducted Test

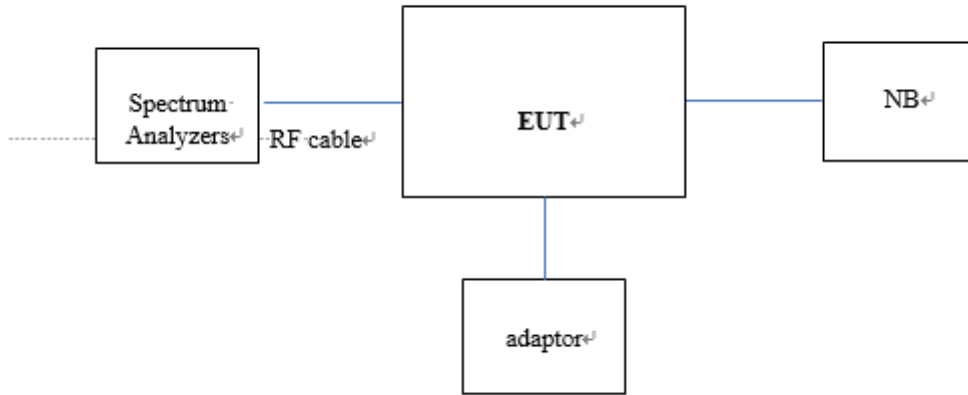

Equipment Used in Tested System

Item	Equipment	Mfr/Brand	Model/Type No.	Series No.	Data Cable	Power Cord
1	NB	HP	440-G1	NA	NA	180cm
2	adaptor	CoreStar	SW24-120U	NA	NA	150cm
3.	Spectrum Analyzers	KEYSIGHT	N9010A	MY5607025 7	NA	NA

1. Equipment cable

Item	Equipment	Mfr/Brand	Model/Type No.	Series No.	Cable loss	Power Cord
1	RF cable	WOEKEN	00100A2H646027	200121OO015	2dB	9cm

Note: All the above equipment/cables were placed in worse case positions to maximize emission signals during emission test.

Grounding: Grounding was in accordance with the manufacturer’s requirements and conditions for the intended use.

3. Summary of Test Results

FCC Rules	Description Of Test	Result
§15.207	AC Power Line Conducted Emission	Compliant
§15.247(b)(1)	Peak Output Power/ EIRP	Compliant
§15.247(a)(1)	20dB Bandwidth	Compliant
§15.247(d)	100 kHz Bandwidth of Frequency Band Edges	Compliant
§15.247(d)	Spurious Emission	Compliant
§15.247(a)(1)	Frequency Separation	Compliant
§15.247(a)(1)(iii)	Number of Hopping Frequency	Compliant
§15.247(a)(1)(ii)	Time of Occupancy	Compliant
§15.203, §15.247(c)	Antenna Requirement	Compliant

4. Description of Test Modes

Test program used to control the EUT for staying in continuous transmitting and receiving mode is programmed.

Channel low (2402MHz), mid (2441MHz), (2480MHz) with each modulation were chosen for full testing.

All mode has been pre-scanned, and only the cast of the worst is presented in the report.

5. AC Line Conduced Emission Test

5.1 Standard Applicable

According to §15.207 , frequency range within 150kHz to 30MHz shall not exceed the Limit table as below.

Frequency range MHz	Limits dB(μV)	
	Quasi-peak	Average
0.15 to 0.50	66 to 56	56 to 46
0.50 to 5	56	46
5 to 30	60	50

Note

- 1.The lower limit shall apply at the transition frequencies
- 2.The limit decreases linearly with the logarithm of the frequency in the range 0.15 MHz to 0.50 MHz.

5.2 Measurement Procedure

1. The EUT was placed on a table which is 0.8m above ground plane.
2. Maximum procedure was performed on the six highest emissions to ensure EUT compliance.
3. Repeat above procedures until all frequency measured were complete.
4. Both 120V & 240V have been verified, and 120V/60Hz was defined as the worst-case and record in the report.

5.3 Measurement Result

- Line

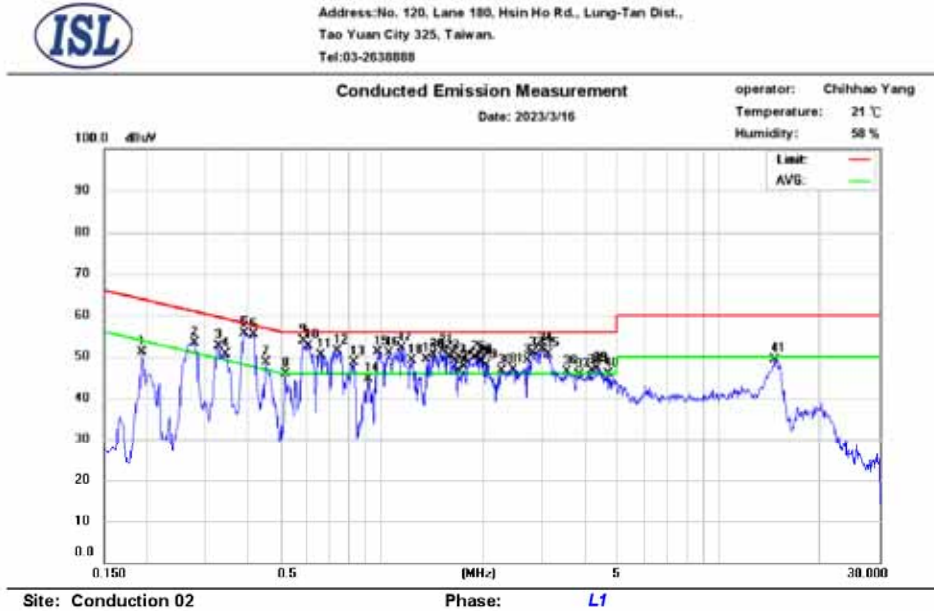

No.	Frequency (MHz)	QP_R (dBuV)	AVG_R (dBuV)	Correct Factor (dB)	QP Emission (dBuV)	QP Limit (dBuV)	QP Margin (dB)	AVG Emission (dBuV)	AVG Limit (dBuV)	AVG Margin (dB)
1	0.194	38.53	26.82	9.64	48.17	63.86	-15.69	36.46	53.86	-17.40
2	0.278	43.22	32.34	9.65	52.87	60.88	-8.01	41.99	50.88	-8.89
3	0.326	41.45	32.60	9.64	51.09	59.55	-8.46	42.24	49.55	-7.31
4	0.345	40.47	31.16	9.64	50.11	59.08	-8.97	40.80	49.08	-8.28
5	0.390	45.48	36.00	9.65	55.13	58.06	-2.93	45.65	48.06	-2.41
6	0.417	44.26	32.61	9.65	53.91	57.51	-3.60	42.26	47.51	-5.25
7	0.450	36.62	24.45	9.65	46.27	56.88	-10.61	34.10	46.88	-12.78
8	0.518	34.67	22.15	9.65	44.32	56.00	-11.68	31.80	46.00	-14.20
9	0.582	43.27	30.14	9.65	52.92	56.00	-3.08	39.79	46.00	-6.21
10	0.606	41.97	29.85	9.65	51.62	56.00	-4.38	39.50	46.00	-6.50
11	0.658	39.62	28.03	9.66	49.28	56.00	-6.72	37.69	46.00	-8.31
12	0.742	41.09	28.27	9.67	50.76	56.00	-5.24	37.94	46.00	-8.06
13	0.830	37.29	23.54	9.67	46.96	56.00	-9.04	33.21	46.00	-12.79
14	0.914	32.72	19.89	9.67	42.39	56.00	-13.61	29.56	46.00	-16.44
15	0.978	40.24	27.44	9.68	49.92	56.00	-6.08	37.12	46.00	-8.88
16	1.054	39.66	26.16	9.68	49.34	56.00	-6.66	35.84	46.00	-10.16
17	1.146	41.42	27.03	9.68	51.10	56.00	-4.90	36.71	46.00	-9.29

Site: Conduction 02 Phase: L1

No.	Frequency (MHz)	QP_R (dBuV)	AVG_R (dBuV)	Correct Factor (dB)	QP Emission (dBuV)	QP Limit (dBuV)	QP Margin (dB)	AVG Emission (dBuV)	AVG Limit (dBuV)	AVG Margin (dB)
18	1.234	37.62	25.21	9.69	47.31	56.00	-8.69	34.90	46.00	-11.10
19	1.358	39.36	27.57	9.69	49.05	56.00	-6.95	37.26	46.00	-8.74
20	1.438	38.69	27.12	9.69	48.38	56.00	-7.62	36.81	46.00	-9.19
21	1.518	40.57	29.52	9.71	50.28	56.00	-5.72	39.23	46.00	-6.77
22	1.590	38.39	27.34	9.71	48.10	56.00	-7.90	37.05	46.00	-8.95
23	1.662	37.94	26.53	9.71	47.65	56.00	-8.35	36.24	46.00	-9.76
24	1.682	34.40	22.33	9.71	44.11	56.00	-11.89	32.04	46.00	-13.96
25	1.758	31.96	21.44	9.71	41.67	56.00	-14.33	31.15	46.00	-14.85
26	1.894	38.32	26.12	9.72	48.04	56.00	-7.96	35.84	46.00	-10.16
27	1.974	36.60	25.76	9.72	46.32	56.00	-9.68	35.48	46.00	-10.52
28	2.002	34.49	25.47	9.72	44.21	56.00	-11.79	35.19	46.00	-10.81
29	2.042	36.10	24.81	9.72	45.82	56.00	-10.18	34.53	46.00	-11.47
30	2.282	34.72	22.46	9.72	44.44	56.00	-11.56	32.18	46.00	-13.82
31	2.458	34.56	23.79	9.73	44.29	56.00	-11.71	33.52	46.00	-12.48
32	2.718	36.81	25.68	9.74	46.55	56.00	-9.45	35.42	46.00	-10.58
33	2.810	37.86	26.70	9.74	47.60	56.00	-8.40	36.44	46.00	-9.56
34	2.978	38.53	29.86	9.74	48.27	56.00	-7.73	39.60	46.00	-6.40
35	3.162	36.39	27.84	9.75	46.14	56.00	-9.86	37.59	46.00	-8.41
36	3.550	33.00	21.57	9.76	42.76	56.00	-13.24	31.33	46.00	-14.67
37	3.846	32.19	23.71	9.77	41.96	56.00	-14.04	33.48	46.00	-12.52
38	4.198	32.78	23.26	9.77	42.55	56.00	-13.45	33.03	46.00	-12.97
39	4.358	32.39	23.87	9.77	42.16	56.00	-13.84	33.64	46.00	-12.36
40	4.698	29.51	21.68	9.78	39.29	56.00	-16.71	31.46	46.00	-14.54
41	14.738	35.56	26.58	9.92	45.48	60.00	-14.52	36.50	50.00	-13.50

Note:

Margin = QP/AVG Emission - Limit

QP/AVG Emission = QP_R/AVG_R + Correct Factor

Correct Factor = LISN Loss + Cable Loss

The frequency spectrum graph is for final peak graph, and the attached table is for QP/AVG test result.

If peak data can pass, it will be shown in "QP/AVG Correct" column, if not, QP/AVG data will instead.

- Neutral

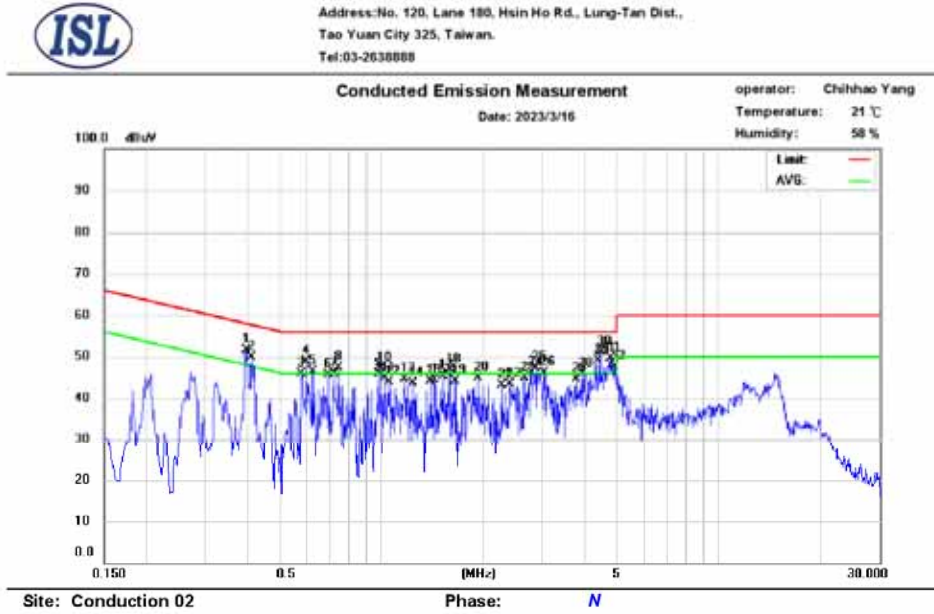

No.	Frequency (MHz)	QP_R (dBuV)	AVG_R (dBuV)	Correct Factor (dB)	QP Emission (dBuV)	QP Limit (dBuV)	QP Margin (dB)	AVG Emission (dBuV)	AVG Limit (dBuV)	AVG Margin (dB)
1	0.394	35.42	26.08	9.65	45.07	57.98	-12.91	35.73	47.98	-12.25
2	0.410	38.68	25.77	9.65	48.33	57.65	-9.32	35.42	47.65	-12.23
3	0.578	27.92	15.01	9.65	37.57	56.00	-18.43	24.66	46.00	-21.34
4	0.598	37.23	20.30	9.65	46.88	56.00	-9.12	29.95	46.00	-16.05
5	0.622	31.71	17.99	9.65	41.36	56.00	-14.64	27.64	46.00	-18.36
6	0.694	32.22	13.56	9.66	41.88	56.00	-14.12	23.22	46.00	-22.78
7	0.722	33.70	18.77	9.67	43.37	56.00	-12.63	28.44	46.00	-17.56
8	0.746	30.86	17.40	9.67	40.53	56.00	-15.47	27.07	46.00	-18.93
9	0.982	33.35	15.64	9.68	43.03	56.00	-12.97	25.32	46.00	-20.68
10	0.998	27.77	14.48	9.68	37.45	56.00	-18.55	24.16	46.00	-21.84
11	1.022	24.96	13.94	9.68	34.64	56.00	-21.36	23.62	46.00	-22.38
12	1.050	29.84	14.62	9.68	39.52	56.00	-16.48	24.30	46.00	-21.70
13	1.166	35.35	18.44	9.68	45.03	56.00	-10.97	28.12	46.00	-17.88
14	1.242	25.89	14.53	9.69	35.58	56.00	-20.42	24.22	46.00	-21.78
15	1.398	30.26	12.70	9.69	39.95	56.00	-16.05	22.39	46.00	-23.61
16	1.434	25.12	14.31	9.69	34.81	56.00	-21.19	24.00	46.00	-22.00
17	1.526	25.76	16.21	9.71	35.47	56.00	-20.53	25.92	46.00	-20.08

Site: Conduction 02 Phase: N

No.	Frequency (MHz)	QP_R (dBuV)	AVG_R (dBuV)	Correct Factor (dB)	QP Emission (dBuV)	QP Limit (dBuV)	QP Margin (dB)	AVG Emission (dBuV)	AVG Limit (dBuV)	AVG Margin (dB)
18	1.594	32.00	16.52	9.71	41.71	56.00	-14.29	26.23	46.00	-19.77
19	1.658	28.06	13.97	9.71	37.77	56.00	-18.23	23.68	46.00	-22.32
20	1.930	31.06	15.82	9.72	40.78	56.00	-15.22	25.54	46.00	-20.46
21	2.266	29.32	12.23	9.72	39.04	56.00	-16.96	21.95	46.00	-24.05
22	2.398	28.51	13.66	9.73	38.24	56.00	-17.76	23.39	46.00	-22.61
23	2.654	29.58	13.01	9.73	39.31	56.00	-16.69	22.74	46.00	-23.26
24	2.782	26.84	15.84	9.73	36.57	56.00	-19.43	25.57	46.00	-20.43
25	2.858	31.62	16.92	9.73	41.35	56.00	-14.65	26.65	46.00	-19.35
26	3.038	27.24	17.35	9.75	36.99	56.00	-19.01	27.10	46.00	-18.90
27	3.766	28.50	12.83	9.76	38.26	56.00	-17.74	22.59	46.00	-23.41
28	3.938	25.32	12.19	9.76	35.08	56.00	-20.92	21.95	46.00	-24.05
29	4.382	32.18	15.21	9.76	41.94	56.00	-14.06	24.97	46.00	-21.03
30	4.454	34.98	16.45	9.77	44.75	56.00	-11.25	26.22	46.00	-19.78
31	4.786	32.10	15.94	9.78	41.88	56.00	-14.12	25.72	46.00	-20.28
32	4.978	30.72	14.81	9.78	40.50	56.00	-15.50	24.59	46.00	-21.41

Note:

Margin = QP/AVG Emission - Limit

QP/AVG Emission = QP_R/AVG_R + Correct Factor

Correct Factor = LISN Loss + Cable Loss

The frequency spectrum graph is for final peak graph, and the attached table is for QP/AVG test result.

If peak data can pass, it will be shown in "QP/AVG Correct" column, if not, QP/AVG data will instead.

6. Peak Output Power Measurement

6.1 Standard Applicable

According to §15.247(b)(1), For frequency hopping systems operating in the 2400-2483.5 MHz band employing at least 75 hopping channels, and all frequency hopping systems in the 5725-5850MHz band: 1Watt. For all other frequency hopping systems in the 2400 – 2483.5MHz band: 0.125 Watts.

6.2 Measurement Procedure

1. Place the EUT on the table and set it in transmitting mode.
2. Remove the antenna from the EUT and then connect a low loss RF cable from the antenna port to the power meter
3. Record the max. reading.
4. Repeat above procedures until all frequency measured were complete.

6.3 Measurement Result

BDR Mode

Frequency (MHz)	Peak Reading Power (dBm)	Output Power (dBm)	Output Power (W)	Limit (dBm)
Low	1.856	1.856	0.00153	30
Mid	4.842	4.842	0.00305	30
High	4.102	4.102	0.00257	30

EDR 2M Mode

Frequency (MHz)	Peak Reading Power (dBm)	Output Power (dBm)	Output Power (W)	Limit (dBm)
Low	1.334	1.334	0.00136	21
Mid	4.347	4.347	0.00272	21
High	3.615	3.615	0.0023	21

EDR 3M Mode

Frequency (MHz)	Peak Reading Power (dBm)	Output Power (dBm)	Output Power (W)	Limit (dBm)
Low	1.337	1.337	0.00136	21
Mid	4.338	4.338	0.00272	21
High	3.601	3.601	0.00229	21

7. Radiated Spurious Emission Test

7.1 Standard Applicable

According to §15.247(d), all other emissions outside these bands shall not exceed the general radiated emission limits specified in §15.209(a). And according to §15.33(a)(1), for an intentional radiator operates below 10GHz, the frequency range of measurements: to the tenth harmonic of the highest fundamental frequency or to 40GHz, whichever is lower.

7.2 Measurement Procedure

1. According 414788 section 2, Either OATS or chamber for radiated emission below 30MHz, the test was done at 966 chamber, the test site was evaluated with OATS and the Chamber has test signals level greater than OATS's.
2. The EUT was placed on a turn table which is 0.8m/1.5m above ground plane in 966 chamber.
3. The turn table shall rotate 360 degrees to determine the position of maximum emission level.
4. EUT is set 3m away from the receiving antenna which varied from 1m to 4m to find out the highest emissions.
5. When measurement procedures for electric field radiated emissions above 1 GHz the EUT measurement is to be made "while keeping the antenna in the 'cone of radiation' from that area and pointed at the area both in azimuth and elevation, with polarization oriented for maximum response." is still within the 3dB illumination BW of the measurement antenna.
6. Maximum procedure was performed on the six highest emissions to ensure EUT compliance.
7. And also, each emission was to be maximized by changing the polarization of receiving antenna both horizontal and vertical.
8. Repeat above procedures until all frequency measured were complete

Test receiver setting	:	Blew 1GHz
Detector	:	Average (9kHz – 90kHz, 110kHz – 90kHz), Quasi-Peak
Bandwidth	:	200Hz, 120kHz
Test spectrum setting	:	Above 1GHz
Peak	:	RBW=1MHz, VBW≥3*RBW, Sweep=auto
Average	:	RBW=1MHz, VBW≥ 1/T _{on} , Sweep=auto

7.3 Field Strength Calculation

The field strength is calculated by adding the Antenna Factor and Cable Factor and subtracting the Amplifier Gain and Duty Cycle Correction Factor (if any) from the measured reading. The basic equation with a sample calculation is as follows:

$$FS = RA + AF + CL - AG$$

Where	FS = Field Strength	CL = Cable Attenuation Factor (Cable Loss)
	RA = Reading Amplitude	AG = Amplifier Gain
	AF = Antenna Factor	

Remark:

<1GHz

1. No further spurious emissions detected from the lowest internal frequency and 30MHz.
2. Measuring frequencies from the lowest internal frequency to the 1GHz.
3. Radiated emissions measured in frequency range from 9kHz to 1000MHz were made with an instrument detector setting 9-90kHz/110-490kHz using PK/AV and other Frequency Band using PK/QP
4. Measurement result within this frequency range shown “ - ” in the table above means the reading of emissions are attenuated more than 20dB below the permissible limits or the field strength is too small to be measured.

>1GHz

- 5 Measuring frequencies from the lowest internal frequency to the 10th of fundamental frequency
- 6 Field strength limits for frequency above 1000MHz are based on average limits. However, Peak mode field strength shall not exceed the average limits specified plus 20dB.
- 7 Measurement of data within this frequency range shown “ - ” in the table above means the reading of emissions are attenuated more than 20dB below the permissible limits or the field strength is too small to be measured.

7.4 Measurement Result

7.4.1 Radiated Spurious Emission Measurement Result (below 30MHz)



International Standard Laboratory Corp.
Company Address: No. 120, Lane 180, Hsin Ho Rd.
Lung-Tan Dist., Tao Yuan City 325, Taiwan

Date: 2023-06-06

Project Number: 23LR0029 Temp.(°C)/RH(%) : 23/51
Test Mode : BT Tx Low ch Tested by : Barry Lee

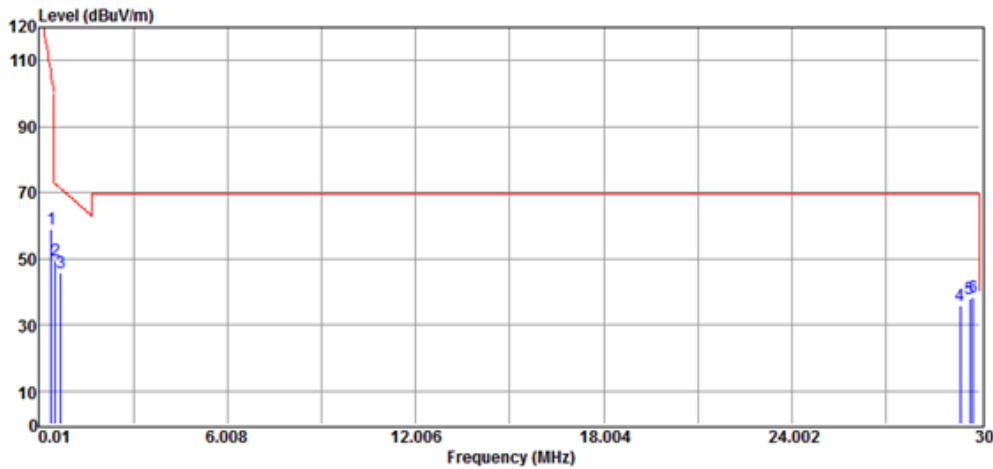

No	Freq MHz	Reading dBuV	Factor dB/m	Level dBuV/m	Limit dBuV/m	Margin dB	Remark	Pol V/H
1	0.40	39.30	19.77	59.07	105.34	-46.27	Peak	VERTICAL
2	0.52	31.88	17.64	49.52	72.75	-23.23	Peak	VERTICAL
3	0.70	29.63	15.98	45.61	71.26	-25.65	Peak	VERTICAL
4	29.37	23.21	12.55	35.76	69.54	-33.78	Peak	VERTICAL
5	29.67	25.13	12.62	37.75	69.54	-31.79	Peak	VERTICAL
6	29.79	25.79	12.64	38.43	69.54	-31.11	Peak	VERTICAL

Factor = AF + CL - AG



International Standard Laboratory Corp.
Company Address: No. 120, Lane 180, Hsin Ho Rd.
Lung-Tan Dist., Tao Yuan City 325, Taiwan

Date: 2023-06-06

Project Number → : 23LR0029 → Temp. (°C)/RH(%) → : 23/51 →
Test Mode → : BT-Tx-Low-ch → Tested by → : Barry-Lee →

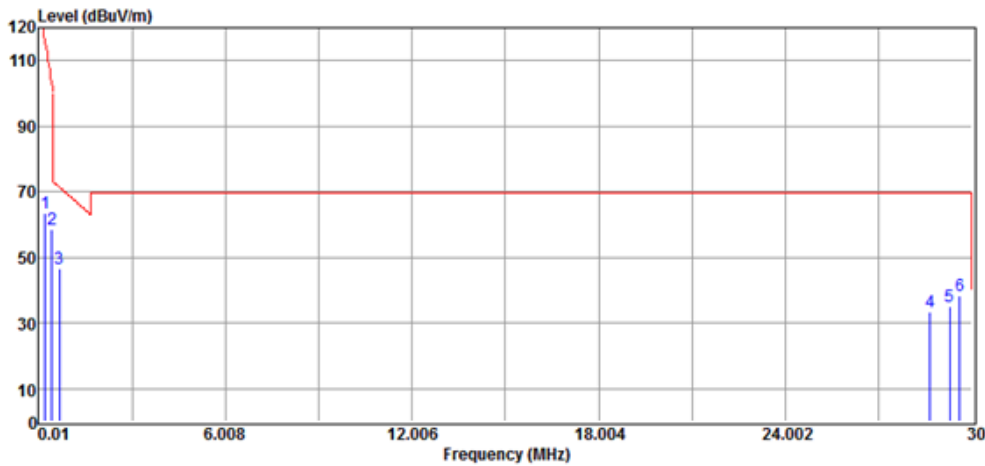

No	Freq MHz	Reading dBuV	Factor dB/m	Level dBuV/m	Limit dBuV/m	Margin dB	Remark	Pol V/H
1	0.22	38.39	24.98	63.37	116.00	-52.63	Peak	HORIZONTAL
2	0.43	39.40	19.15	58.55	103.56	-45.01	Peak	HORIZONTAL
3	0.67	30.30	16.23	46.53	71.51	-24.98	Peak	HORIZONTAL
4	28.65	21.02	12.41	33.43	69.54	-36.11	Peak	HORIZONTAL
5	29.28	22.67	12.53	35.20	69.54	-34.34	Peak	HORIZONTAL
6	29.61	25.77	12.61	38.38	69.54	-31.16	Peak	HORIZONTAL

Factor = AF + CL - AG



International Standard Laboratory Corp.
Company Address: No. 120, Lane 180, Hsin Ho Rd.
Lung-Tan Dist., Tao-Yuan City 325, Taiwan

Date: 2023-06-06

Project Number: 23LR0029 → Temp.(°C)/RH(%) → 23/51 →
Test Mode → BT Tx Mid ch → Tested by → Barry Lee →

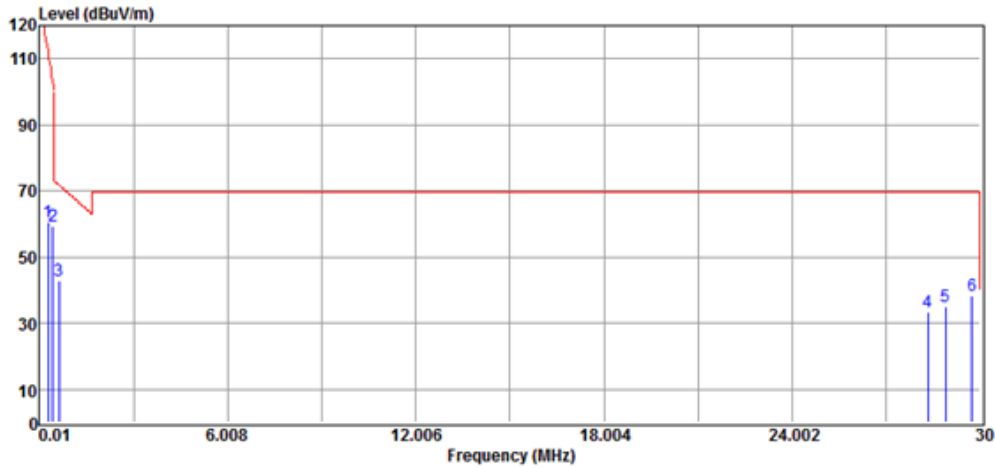

No	Freq MHz	Reading dBuV	Factor dB/m	Level dBuV/m	Limit dBuV/m	Margin dB	Remark	Pol V/H
1	0.28	37.81	22.86	60.67	112.45	-51.78	Peak	VERTICAL
2	0.43	40.09	19.15	59.24	103.56	-44.32	Peak	VERTICAL
3	0.64	26.55	16.48	43.03	71.75	-28.72	Peak	VERTICAL
4	28.32	21.19	12.33	33.52	69.54	-36.02	Peak	VERTICAL
5	28.89	22.65	12.46	35.11	69.54	-34.43	Peak	VERTICAL
6	29.73	25.73	12.63	38.36	69.54	-31.18	Peak	VERTICAL

Factor = AF + CL - AG



International Standard Laboratory Corp.
Company Address: No.120, Lane 180, Hsin Ho Rd.
Lung-Tan Dist., Tao Yuan City 325, Taiwan

Date: 2023-06-06

Project Number: 23LR0029 Temp.(°C)/RH(%) : 23/51
Test Mode : BT Tx Mid ch Tested by : Barry Lee

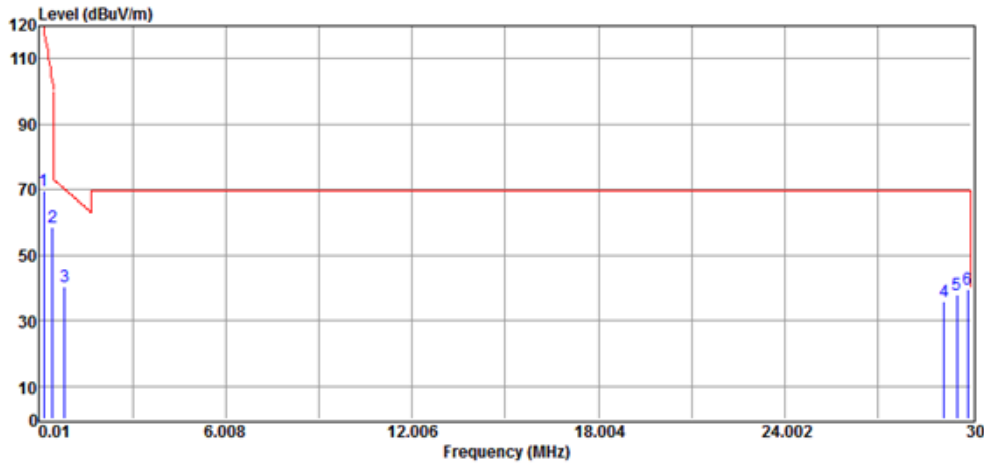

No	Freq MHz	Reading dBuV	Factor dB/m	Level dBuV/m	Limit dBuV/m	Margin dB	Remark	Pol V/H
1	0.16	41.87	27.81	69.68	119.56	-49.88	Peak	HORIZONTAL
2	0.43	39.50	19.15	58.65	103.56	-44.91	Peak	HORIZONTAL
3	0.82	25.38	15.10	40.48	70.26	-29.78	Peak	HORIZONTAL
4	29.13	23.27	12.50	35.77	69.54	-33.77	Peak	HORIZONTAL
5	29.55	25.40	12.59	37.99	69.54	-31.55	Peak	HORIZONTAL
6	29.88	27.12	12.66	39.78	69.54	-29.76	Peak	HORIZONTAL

Factor = AF + CL - AG



International Standard Laboratory Corp.
Company Address: No.120, Lane 180, Hsin Ho Rd.
Lung-Tan Dist., Tao Yuan City 325, Taiwan

Date: 2023-06-06

Project Number: 23LR0029 → Temp.(°C)/RH(%) → 23/51 →
Test Mode → BT Tx High ch → Tested by → Barry Lee →

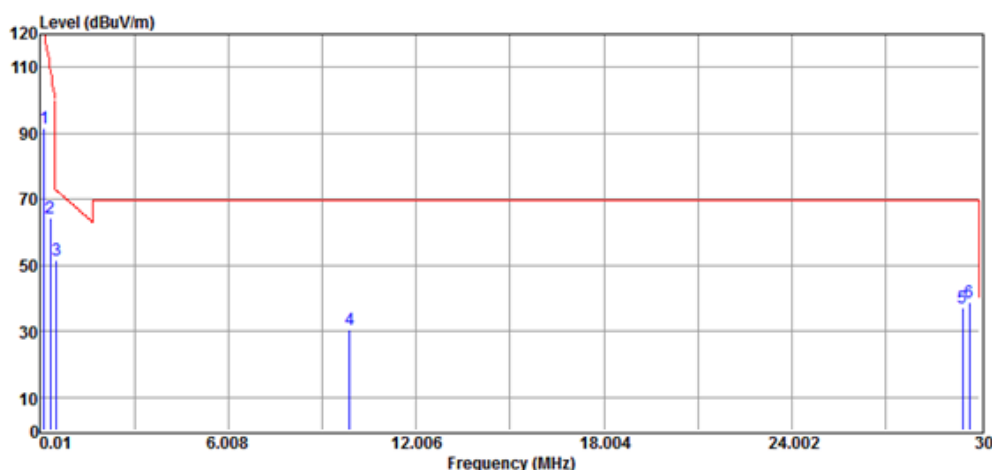

No	Freq MHz	Reading dBuV	Factor dB/m	Level dBuV/m	Limit dBuV/m	Margin dB	Remark	Pol V/H
1	0.13	61.85	29.65	91.50	121.33	-29.83	Peak	VERTICAL
2	0.34	43.17	21.16	64.33	108.89	-44.56	Peak	VERTICAL
3	0.52	34.01	17.64	51.65	72.75	-21.10	Peak	VERTICAL
4	9.88	19.01	11.53	30.54	69.54	-39.00	Peak	VERTICAL
5	29.46	24.33	12.58	36.91	69.54	-32.63	Peak	VERTICAL
6	29.67	26.12	12.62	38.74	69.54	-30.80	Peak	VERTICAL

Factor = AF + CL - AG



International Standard Laboratory Corp.
Company Address: No.120, Lane 180, Hsin Ho Rd.
Lung-Tan Dist., Tao Yuan City 325, Taiwan

Date: 2023-06-06

Project Number. → : 23LR0029 → Temp.(°C)/RH(%) → : 23/51 →
Test Mode → : BT Tx High ch → Tested by → : Barry Lee →

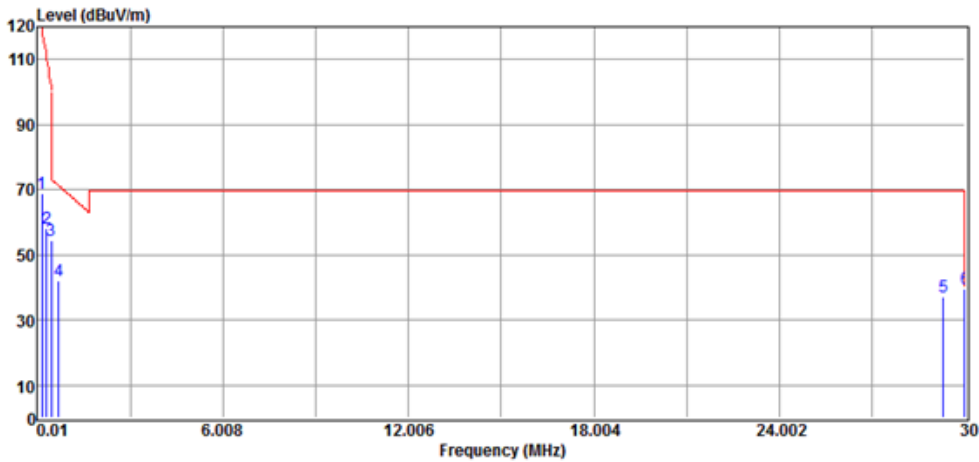

No	Freq MHz	Reading dBuV	Factor dB/m	Level dBuV/m	Limit dBuV/m	Margin dB	Remark	Pol V/H
1	0.16	41.09	27.81	68.90	119.56	-50.66	Peak	HORIZONTAL
2	0.31	35.99	21.96	57.95	110.67	-52.72	Peak	HORIZONTAL
3	0.46	35.83	18.58	54.41	101.79	-47.38	Peak	HORIZONTAL
4	0.70	25.89	15.98	41.87	71.26	-29.39	Peak	HORIZONTAL
5	29.31	24.40	12.54	36.94	69.54	-32.60	Peak	HORIZONTAL
6	30.00	26.79	12.68	39.47	40.00	-0.53	Peak	HORIZONTAL

Factor = AF + CL - AG

7.4.2 Radiated Spurious Emission Measurement Result (below 1GHz)

International Standard Laboratory Corp.
Company Address: No.120, Lane 180, Hsin Ho Rd.
Lung-Tan Dist., Tao Yuan City 325, Taiwan
Date: 2023-03-15

Project Number. : 23LR0029 Temp.()/RH(%) : 23/51
Test Mode : BT 1M Tx Low ch Tested by : Barry Lee

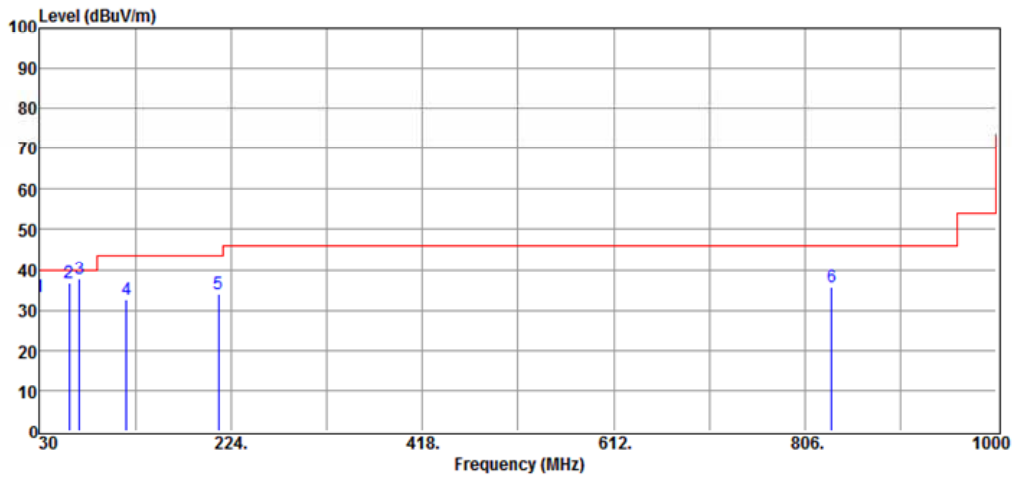

No	Freq MHz	Reading dBuV	Factor dB/m	Level dBuV/m	Limit dBuV/m	Margin dB	Remark	Pol V/H
1	30.00	40.37	-7.02	33.35	40.00	-6.65	Peak	VERTICAL
2	60.07	42.84	-6.08	36.76	40.00	-3.24	Peak	VERTICAL
3	70.74	45.73	-8.06	37.67	40.00	-2.33	Peak	VERTICAL
4	118.27	40.84	-8.14	32.70	43.50	-10.80	Peak	VERTICAL
5	211.39	41.96	-7.85	34.11	43.50	-9.39	Peak	VERTICAL
6	833.16	30.21	5.41	35.62	46.00	-10.38	Peak	VERTICAL

Factor = AF + CL - AG

International Standard Laboratory Corp.
 Company Address: No.120, Lane 180, Hsin Ho Rd.
 Lung-Tan Dist., Tao Yuan City 325, Taiwan
 Date: 2023-03-15

Project Number. : 23LR0029 Temp.()/RH(%) : 23/51
 Test Mode : BT 1M Tx Low ch Tested by : Barry Lee

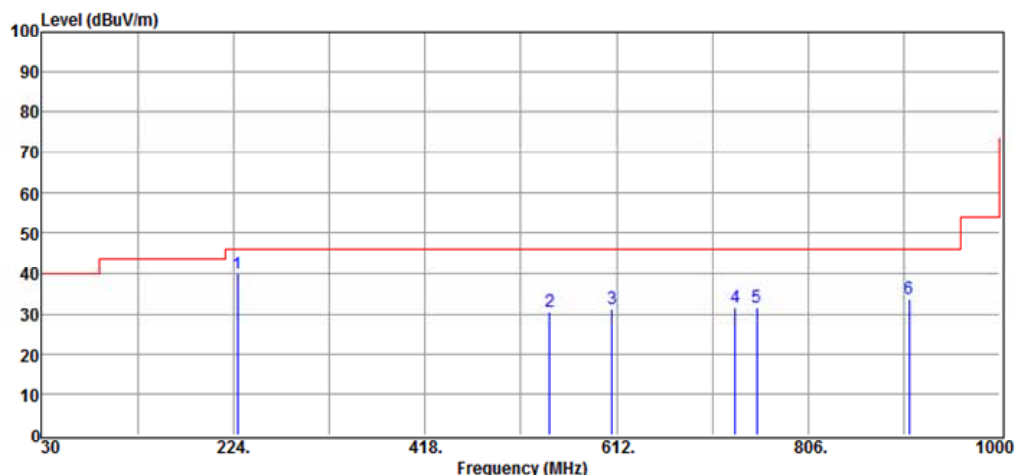

No	Freq MHz	Reading dBuV	Factor dB/m	Level dBuV/m	Limit dBuV/m	Margin dB	Remark	Pol V/H
1	227.88	47.84	-7.91	39.93	46.00	-6.07	Peak	HORIZONTAL
2	544.10	30.35	0.10	30.45	46.00	-15.55	Peak	HORIZONTAL
3	607.15	29.37	1.82	31.19	46.00	-14.81	Peak	HORIZONTAL
4	732.28	27.83	3.68	31.51	46.00	-14.49	Peak	HORIZONTAL
5	753.62	27.23	4.52	31.75	46.00	-14.25	Peak	HORIZONTAL
6	907.85	27.05	6.65	33.70	46.00	-12.30	Peak	HORIZONTAL

Factor = AF + CL - AG

International Standard Laboratory Corp.
Company Address: No.120, Lane 180, Hsin Ho Rd.
Lung-Tan Dist., Tao Yuan City 325, Taiwan

Date: 2023-03-15

Project Number. : 23LR0029 Temp.()/RH(%) : 23/51
Test Mode : BT 1M Tx Mid ch Tested by : Barry Lee

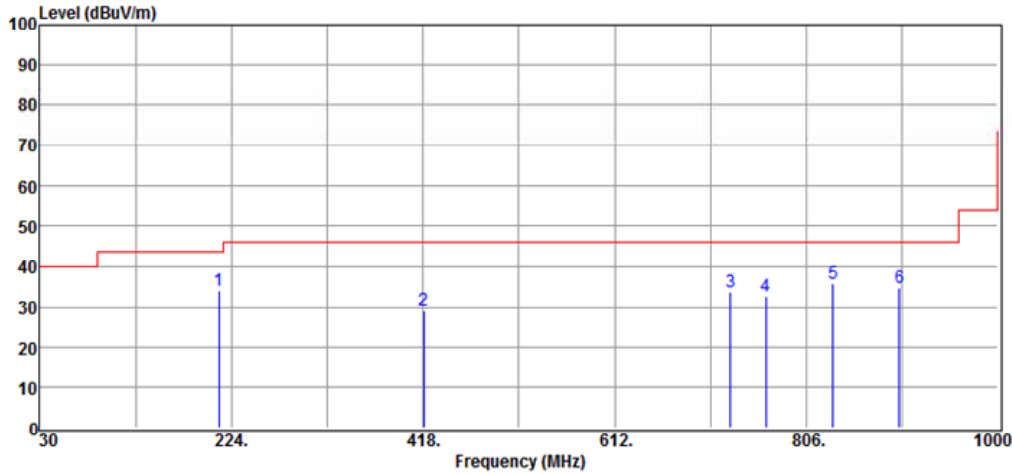

No	Freq MHz	Reading dBuV	Factor dB/m	Level dBuV/m	Limit dBuV/m	Margin dB	Remark	Pol V/H
1	211.39	41.82	-7.85	33.97	43.50	-9.53	Peak	VERTICAL
2	418.97	31.40	-2.12	29.28	46.00	-16.72	Peak	VERTICAL
3	729.37	30.11	3.57	33.68	46.00	-12.32	Peak	VERTICAL
4	765.26	28.00	4.64	32.64	46.00	-13.36	Peak	VERTICAL
5	833.16	30.40	5.41	35.81	46.00	-10.19	Peak	VERTICAL
6	900.09	28.28	6.42	34.70	46.00	-11.30	Peak	VERTICAL

Factor = AF + CL - AG

International Standard Laboratory Corp.
 Company Address: No.120, Lane 180, Hsin Ho Rd.
 Lung-Tan Dist., Tao Yuan City 325, Taiwan
 Date: 2023-03-15

Project Number. : 23LR0029 Temp.()/RH(%) : 23/51
 Test Mode : BT 1M Tx Mid ch Tested by : Barry Lee

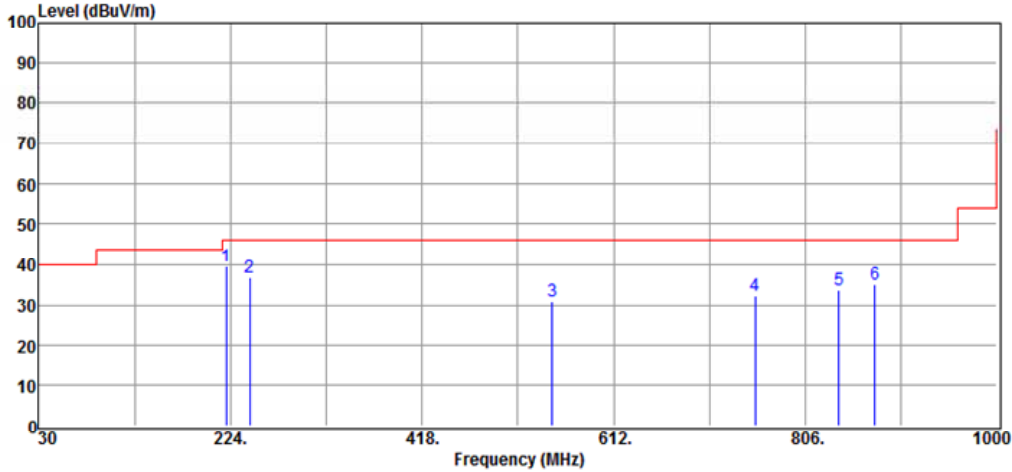

No	Freq MHz	Reading dBuV	Factor dB/m	Level dBuV/m	Limit dBuV/m	Margin dB	Remark	Pol V/H
1	220.12	47.48	-7.83	39.65	46.00	-6.35	Peak	HORIZONTAL
2	243.40	42.81	-6.19	36.62	46.00	-9.38	Peak	HORIZONTAL
3	549.92	30.83	0.13	30.96	46.00	-15.04	Peak	HORIZONTAL
4	755.56	27.94	4.51	32.45	46.00	-13.55	Peak	HORIZONTAL
5	839.95	28.27	5.51	33.78	46.00	-12.22	Peak	HORIZONTAL
6	876.81	29.28	5.81	35.09	46.00	-10.91	Peak	HORIZONTAL

Factor = AF + CL - AG

International Standard Laboratory Corp.
 Company Address: No.120, Lane 180, Hsin Ho Rd.
 Lung-Tan Dist., Tao Yuan City 325, Taiwan
 Date: 2023-03-15

Project Number. : 23LR0029 Temp.()/RH(%) : 23/51
 Test Mode : BT 1M Tx High ch Tested by : Barry Lee

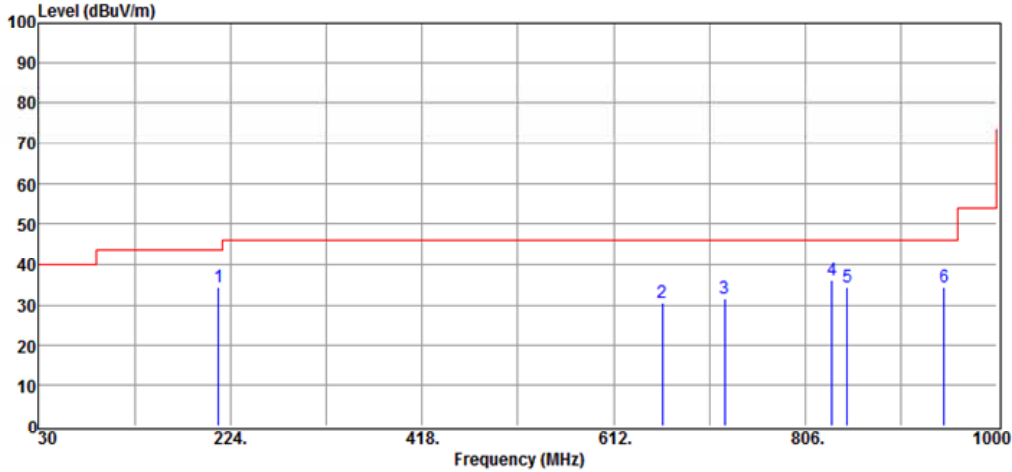

No	Freq MHz	Reading dBuV	Factor dB/m	Level dBuV/m	Limit dBuV/m	Margin dB	Remark	Pol V/H
1	212.36	42.08	-7.83	34.25	43.50	-9.25	Peak	VERTICAL
2	661.47	28.24	2.37	30.61	46.00	-15.39	Peak	VERTICAL
3	724.52	28.15	3.51	31.66	46.00	-14.34	Peak	VERTICAL
4	833.16	30.55	5.41	35.96	46.00	-10.04	Peak	VERTICAL
5	848.68	28.66	5.56	34.22	46.00	-11.78	Peak	VERTICAL
6	946.65	27.27	7.12	34.39	46.00	-11.61	Peak	VERTICAL

Factor = AF + CL - AG

International Standard Laboratory Corp.
 Company Address: No.120, Lane 180, Hsin Ho Rd.
 Lung-Tan Dist., Tao Yuan City 325, Taiwan
 Date: 2023-03-15

Project Number. : 23LR0029 Temp.()/RH(%) : 23/51
 Test Mode : BT 1M Tx High ch Tested by : Barry Lee

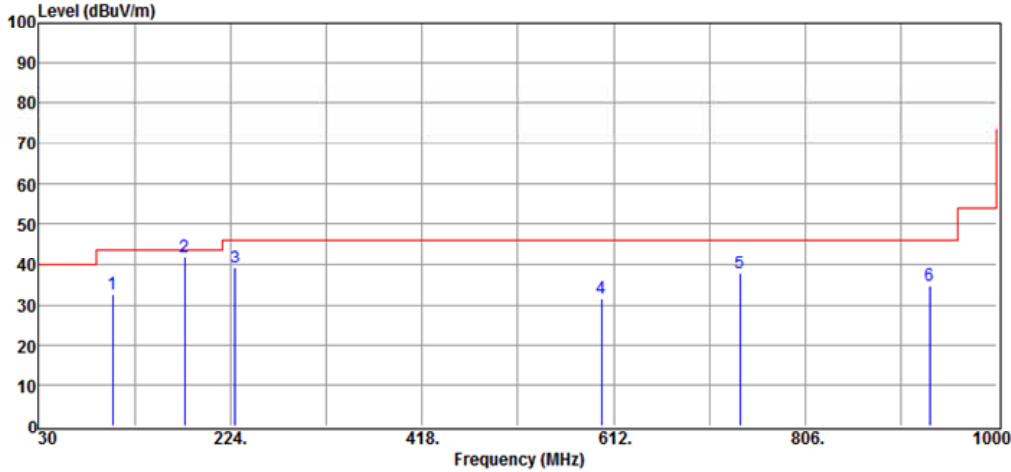

No	Freq MHz	Reading dBuV	Factor dB/m	Level dBuV/m	Limit dBuV/m	Margin dB	Remark	Pol V/H
1	104.69	41.98	-9.39	32.59	43.50	-10.91	Peak	HORIZONTAL
2	177.44	48.02	-6.25	41.77	43.50	-1.73	Peak	HORIZONTAL
3	228.85	47.15	-7.85	39.30	46.00	-6.70	Peak	HORIZONTAL
4	599.39	29.89	1.78	31.67	46.00	-14.33	Peak	HORIZONTAL
5	740.04	33.72	4.03	37.75	46.00	-8.25	Peak	HORIZONTAL
6	932.10	27.51	7.04	34.55	46.00	-11.45	Peak	HORIZONTAL

Factor = AF + CL - AG

International Standard Laboratory Corp.
 Company Address: No.120, Lane 180, Hsin Ho Rd.
 Lung-Tan Dist., Tao Yuan City 325, Taiwan

Date: 2023-03-15

Project Number. : 23LR0029 Temp.()/RH(%) : 23/51
 Test Mode : BT 2M Tx Low ch Tested by : Barry Lee

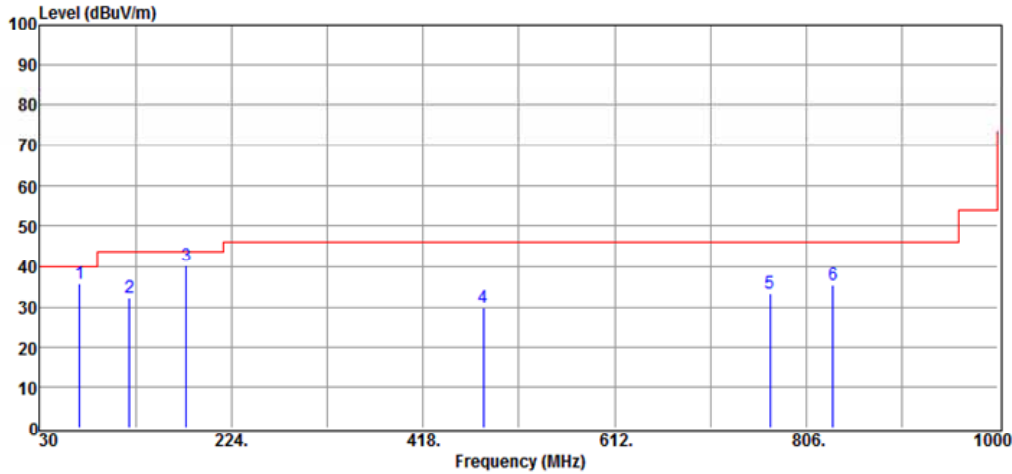

No	Freq MHz	Reading dBuV	Factor dB/m	Level dBuV/m	Limit dBuV/m	Margin dB	Remark	Pol V/H
1	70.74	43.76	-8.06	35.70	40.00	-4.30	Peak	VERTICAL
2	121.18	40.15	-7.89	32.26	43.50	-11.24	Peak	VERTICAL
3	178.41	46.57	-6.31	40.26	43.50	-3.24	Peak	VERTICAL
4	479.11	30.59	-0.70	29.89	46.00	-16.11	Peak	VERTICAL
5	769.14	28.68	4.66	33.34	46.00	-12.66	Peak	VERTICAL
6	833.16	29.84	5.41	35.25	46.00	-10.75	Peak	VERTICAL

Factor = AF + CL - AG

International Standard Laboratory Corp.
Company Address: No.120, Lane 180, Hsin Ho Rd.
Lung-Tan Dist., Tao Yuan City 325, Taiwan
Date: 2023-03-15

Project Number. : 23LR0029 Temp.()/RH(%) : 23/51
Test Mode : BT 2M Tx Low ch Tested by : Barry Lee

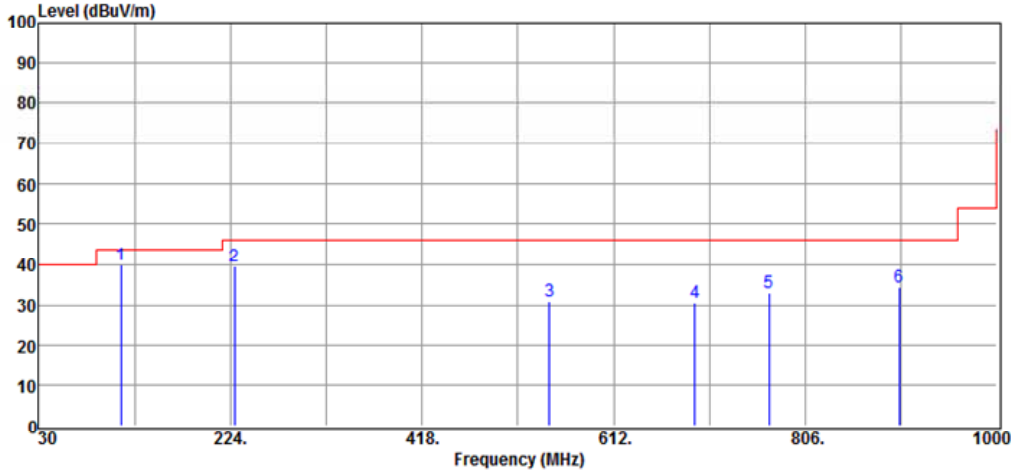

No	Freq MHz	Reading dBuV	Factor dB/m	Level dBuV/m	Limit dBuV/m	Margin dB	Remark	Pol V/H
1	113.42	48.45	-8.57	39.88	43.50	-3.62	Peak	HORIZONTAL
2	227.88	47.56	-7.91	39.65	46.00	-6.35	Peak	HORIZONTAL
3	547.01	30.72	0.12	30.84	46.00	-15.16	Peak	HORIZONTAL
4	694.45	27.36	3.11	30.47	46.00	-15.53	Peak	HORIZONTAL
5	769.14	28.38	4.66	33.04	46.00	-12.96	Peak	HORIZONTAL
6	901.06	28.05	6.44	34.49	46.00	-11.51	Peak	HORIZONTAL

Factor = AF + CL - AG

International Standard Laboratory Corp.
Company Address: No.120, Lane 180, Hsin Ho Rd.
Lung-Tan Dist., Tao Yuan City 325, Taiwan
Date: 2023-03-15

Project Number. : 23LR0029 Temp.()/RH(%) : 23/51
Test Mode : BT 2M Tx Mid ch Tested by : Barry Lee

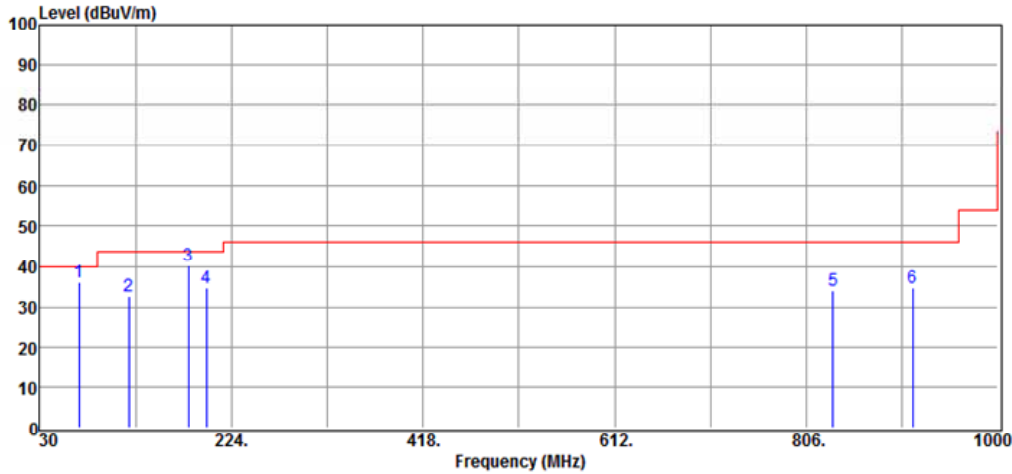

No	Freq MHz	Reading dBuV	Factor dB/m	Level dBuV/m	Limit dBuV/m	Margin dB	Remark	Pol V/H
1	69.77	44.16	-8.07	36.09	40.00	-3.91	Peak	VERTICAL
2	120.21	40.45	-7.95	32.50	43.50	-11.00	Peak	VERTICAL
3	180.35	46.65	-6.50	40.15	43.50	-3.35	Peak	VERTICAL
4	198.78	42.66	-7.95	34.71	43.50	-8.79	Peak	VERTICAL
5	833.16	28.76	5.41	34.17	46.00	-11.83	Peak	VERTICAL
6	913.67	27.88	6.70	34.58	46.00	-11.42	Peak	VERTICAL

Factor = AF + CL - AG

International Standard Laboratory Corp.
 Company Address: No.120, Lane 180, Hsin Ho Rd.
 Lung-Tan Dist., Tao Yuan City 325, Taiwan
 Date: 2023-03-15

Project Number. : 23LR0029 Temp.()/RH(%) : 23/51
 Test Mode : BT 2M Tx Mid ch Tested by : Barry Lee

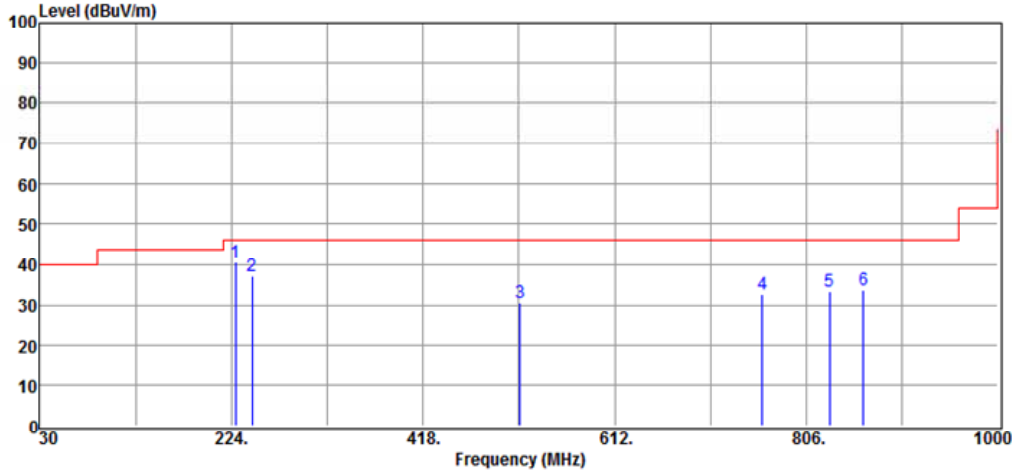

No	Freq MHz	Reading dBuV	Factor dB/m	Level dBuV/m	Limit dBuV/m	Margin dB	Remark	Pol V/H
1	227.88	48.30	-7.91	40.39	46.00	-5.61	Peak	HORIZONTAL
2	245.34	43.06	-6.07	36.99	46.00	-9.01	Peak	HORIZONTAL
3	515.97	30.92	-0.20	30.72	46.00	-15.28	Peak	HORIZONTAL
4	761.38	28.00	4.62	32.62	46.00	-13.38	Peak	HORIZONTAL
5	829.28	28.11	5.26	33.37	46.00	-12.63	Peak	HORIZONTAL
6	864.20	27.73	5.82	33.55	46.00	-12.45	Peak	HORIZONTAL

Factor = AF + CL - AG

International Standard Laboratory Corp.
Company Address: No.120, Lane 180, Hsin Ho Rd.
Lung-Tan Dist., Tao Yuan City 325, Taiwan
Date: 2023-03-15

Project Number. : 23LR0029 Temp.()/RH(%) : 23/51
Test Mode : BT 2M Tx High ch Tested by : Barry Lee

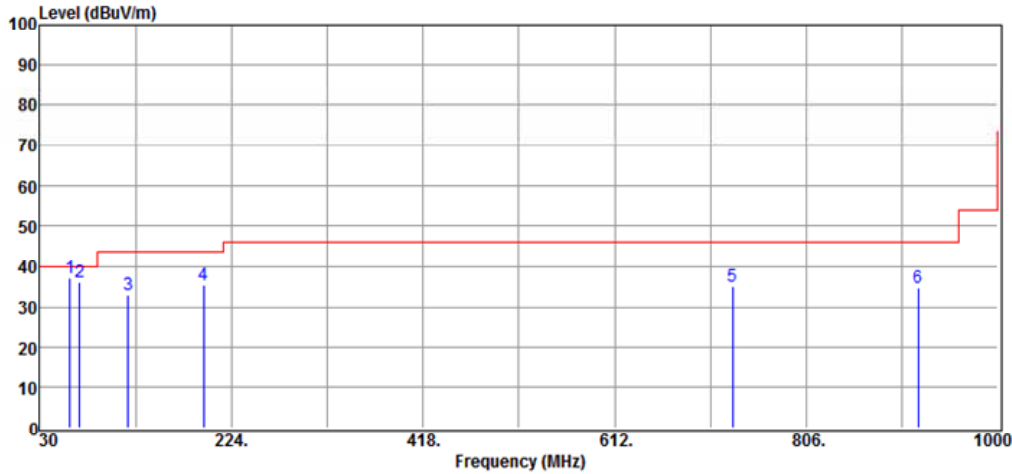

No	Freq MHz	Reading dBuV	Factor dB/m	Level dBuV/m	Limit dBuV/m	Margin dB	Remark	Pol V/H
1	61.04	43.41	-6.44	36.97	40.00	-3.03	Peak	VERTICAL
2	70.74	43.98	-8.06	35.92	40.00	-4.08	Peak	VERTICAL
3	119.24	40.95	-8.03	32.92	43.50	-10.58	Peak	VERTICAL
4	195.87	43.27	-7.87	35.40	43.50	-8.10	Peak	VERTICAL
5	731.31	31.47	3.64	35.11	46.00	-10.89	Peak	VERTICAL
6	919.49	27.90	6.69	34.59	46.00	-11.41	Peak	VERTICAL

Factor = AF + CL - AG

International Standard Laboratory Corp.
 Company Address: No.120, Lane 180, Hsin Ho Rd.
 Lung-Tan Dist., Tao Yuan City 325, Taiwan
 Date: 2023-03-15

Project Number. : 23LR0029 Temp.()/RH(%) : 23/51
 Test Mode : BT 2M Tx High ch Tested by : Barry Lee

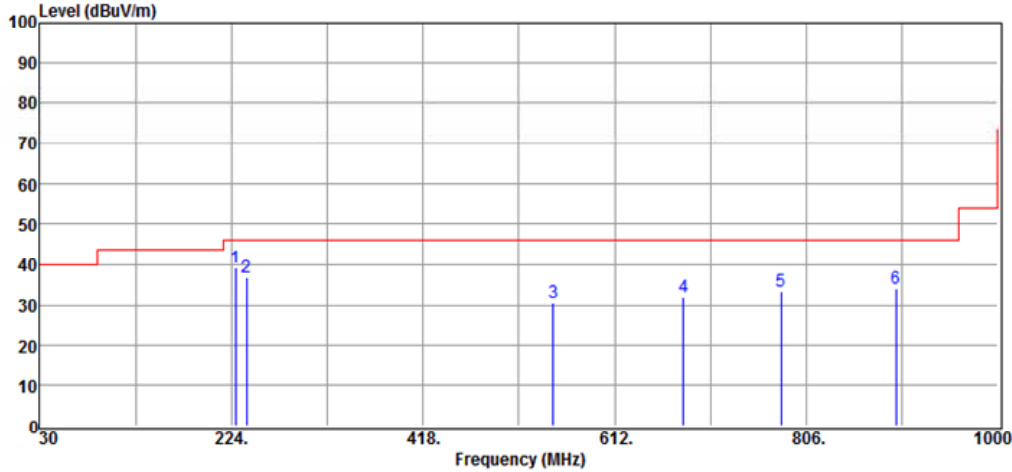

No	Freq MHz	Reading dBuV	Factor dB/m	Level dBuV/m	Limit dBuV/m	Margin dB	Remark	Pol V/H
1	227.88	47.07	-7.91	39.16	46.00	-6.84	Peak	HORIZONTAL
2	239.52	43.23	-6.46	36.77	46.00	-9.23	Peak	HORIZONTAL
3	549.92	30.56	0.13	30.69	46.00	-15.31	Peak	HORIZONTAL
4	681.84	28.96	2.94	31.90	46.00	-14.10	Peak	HORIZONTAL
5	780.78	28.72	4.70	33.42	46.00	-12.58	Peak	HORIZONTAL
6	897.18	27.56	6.29	33.85	46.00	-12.15	Peak	HORIZONTAL

Factor = AF + CL - AG

International Standard Laboratory Corp.
Company Address: No.120, Lane 180, Hsin Ho Rd.
Lung-Tan Dist., Tao Yuan City 325, Taiwan
Date: 2023-03-15

Project Number. : 23LR0029 Temp.()/RH(%) : 23/51
Test Mode : BT 3M Tx Low ch Tested by : Barry Lee

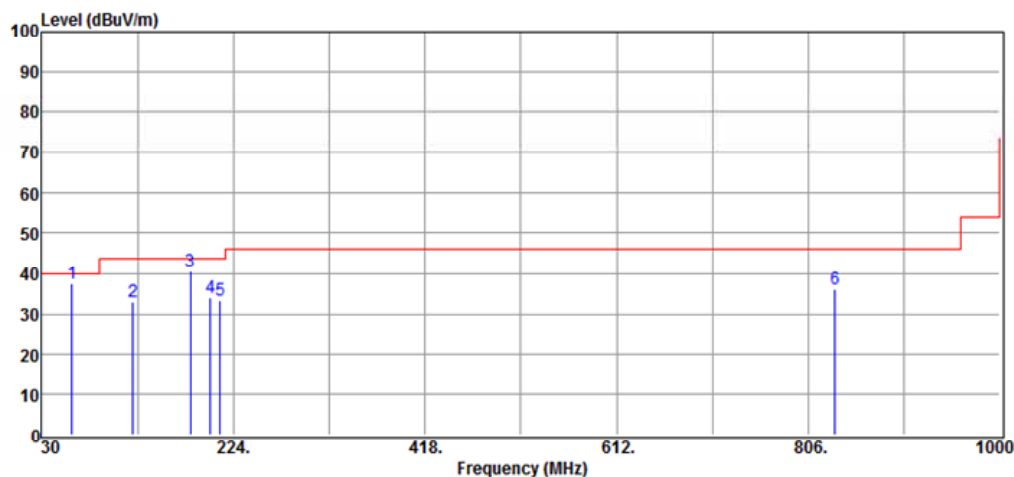

No	Freq MHz	Reading dBuV	Factor dB/m	Level dBuV/m	Limit dBuV/m	Margin dB	Remark	Pol V/H
1	61.04	43.82	-6.44	37.38	40.00	-2.62	Peak	VERTICAL
2	122.15	40.58	-7.69	32.89	43.50	-10.61	Peak	VERTICAL
3	180.35	47.04	-6.50	40.54	43.50	-2.96	Peak	VERTICAL
4	200.72	42.02	-7.96	34.06	43.50	-9.44	Peak	VERTICAL
5	210.42	41.21	-7.87	33.34	43.50	-10.16	Peak	VERTICAL
6	833.16	30.52	5.41	35.93	46.00	-10.07	Peak	VERTICAL

Factor = AF + CL - AG

International Standard Laboratory Corp.
 Company Address: No.120, Lane 180, Hsin Ho Rd.
 Lung-Tan Dist., Tao Yuan City 325, Taiwan
 Date: 2023-03-15

Project Number. : 23LR0029 Temp.()/RH(%) : 23/51
 Test Mode : BT 3M Tx Low ch Tested by : Barry Lee

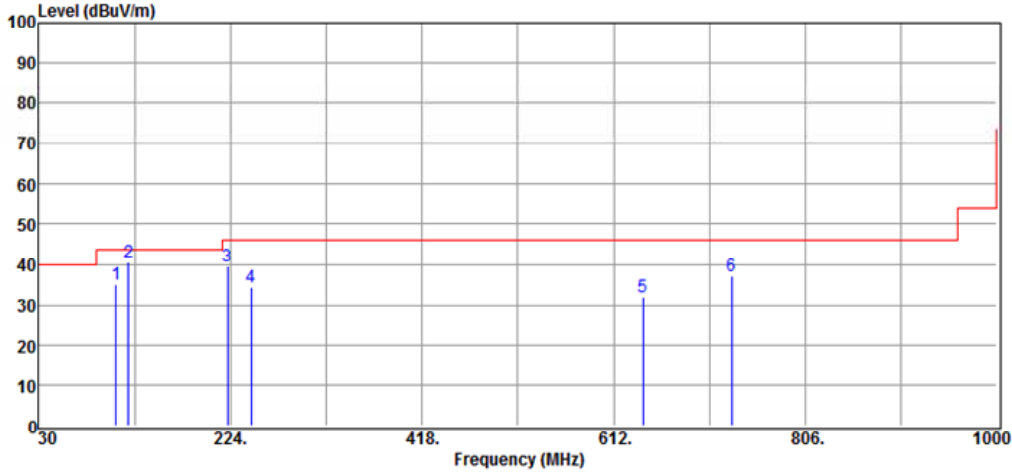

No	Freq MHz	Reading dBuV	Factor dB/m	Level dBuV/m	Limit dBuV/m	Margin dB	Remark	Pol V/H
1	108.57	44.10	-8.96	35.14	43.50	-8.36	Peak	HORIZONTAL
2	121.18	48.38	-7.89	40.49	43.50	-3.01	Peak	HORIZONTAL
3	221.09	47.39	-7.89	39.50	46.00	-6.50	Peak	HORIZONTAL
4	245.34	40.55	-6.07	34.48	46.00	-11.52	Peak	HORIZONTAL
5	642.07	29.45	2.38	31.83	46.00	-14.17	Peak	HORIZONTAL
6	731.31	33.50	3.64	37.14	46.00	-8.86	Peak	HORIZONTAL

Factor = AF + CL - AG

International Standard Laboratory Corp.
Company Address: No.120, Lane 180, Hsin Ho Rd.
Lung-Tan Dist., Tao Yuan City 325, Taiwan
Date: 2023-03-15

Project Number. : 23LR0029 Temp.()/RH(%) : 23/51
Test Mode : BT 3M Tx Mid ch Tested by : Barry Lee

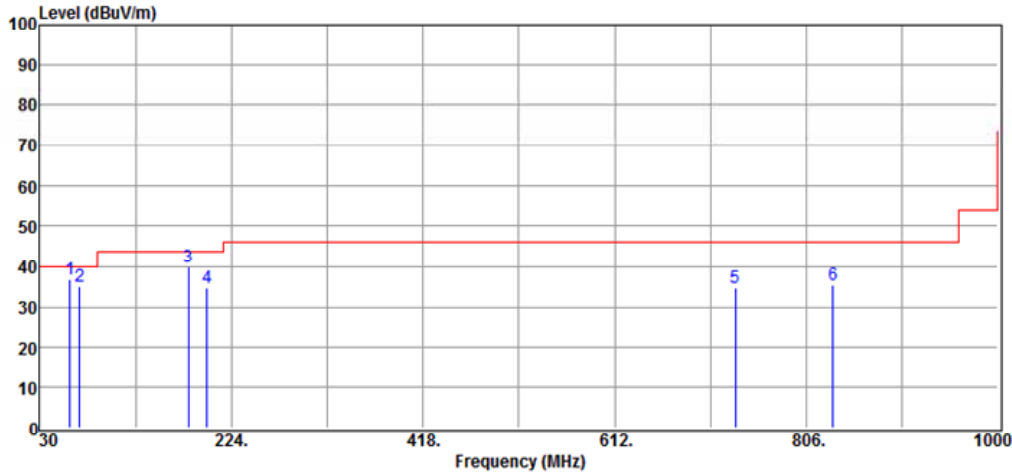

No	Freq MHz	Reading dBuV	Factor dB/m	Level dBuV/m	Limit dBuV/m	Margin dB	Remark	Pol V/H
1	61.04	43.36	-6.44	36.92	40.00	-3.08	Peak	VERTICAL
2	70.74	43.26	-8.06	35.20	40.00	-4.80	Peak	VERTICAL
3	180.35	46.53	-6.50	40.03	43.50	-3.47	Peak	VERTICAL
4	199.75	42.72	-7.95	34.77	43.50	-8.73	Peak	VERTICAL
5	734.22	30.84	3.77	34.61	46.00	-11.39	Peak	VERTICAL
6	833.16	29.91	5.41	35.32	46.00	-10.68	Peak	VERTICAL

Factor = AF + CL - AG

International Standard Laboratory Corp.
 Company Address: No.120, Lane 180, Hsin Ho Rd.
 Lung-Tan Dist., Tao Yuan City 325, Taiwan
 Date: 2023-03-15

Project Number. : 23LR0029 Temp.()/RH(%) : 23/51
 Test Mode : BT 3M Tx Mid ch Tested by : Barry Lee

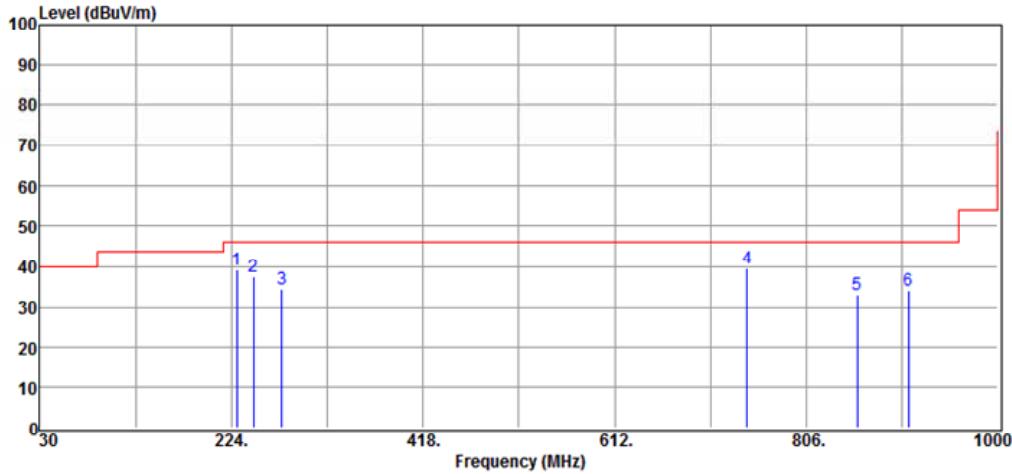

No	Freq MHz	Reading dBuV	Factor dB/m	Level dBuV/m	Limit dBuV/m	Margin dB	Remark	Pol V/H
1	229.82	46.89	-7.78	39.11	46.00	-6.89	Peak	HORIZONTAL
2	246.31	43.59	-6.05	37.54	46.00	-8.46	Peak	HORIZONTAL
3	275.41	39.18	-4.71	34.47	46.00	-11.53	Peak	HORIZONTAL
4	745.86	35.02	4.38	39.40	46.00	-6.60	Peak	HORIZONTAL
5	857.41	27.18	5.66	32.84	46.00	-13.16	Peak	HORIZONTAL
6	909.79	27.41	6.75	34.16	46.00	-11.84	Peak	HORIZONTAL

Factor = AF + CL - AG

International Standard Laboratory Corp.
Company Address: No.120, Lane 180, Hsin Ho Rd.
Lung-Tan Dist., Tao Yuan City 325, Taiwan
Date: 2023-03-15

Project Number. : 23LR0029 Temp.()/RH(%) : 23/51
Test Mode : BT 3M Tx High ch Tested by : Barry Lee

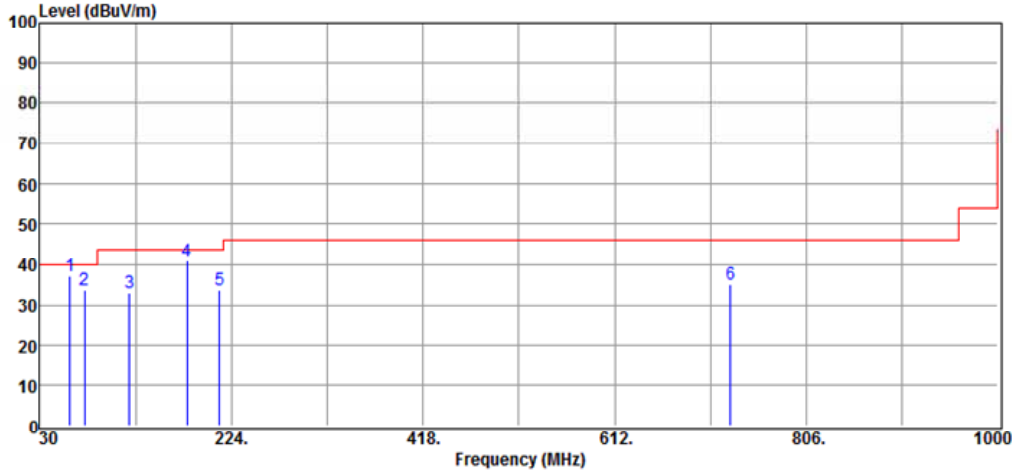

No	Freq MHz	Reading dBuV	Factor dB/m	Level dBuV/m	Limit dBuV/m	Margin dB	Remark	Pol V/H
1	61.04	43.66	-6.44	37.22	40.00	-2.78	Peak	VERTICAL
2	75.59	42.70	-8.90	33.80	40.00	-6.20	Peak	VERTICAL
3	121.18	40.91	-7.89	33.02	43.50	-10.48	Peak	VERTICAL
4	179.38	47.16	-6.33	40.83	43.50	-2.67	Peak	VERTICAL
5	212.36	41.49	-7.83	33.66	43.50	-9.84	Peak	VERTICAL
6	729.37	31.44	3.57	35.01	46.00	-10.99	Peak	VERTICAL

Factor = AF + CL - AG

International Standard Laboratory Corp.
 Company Address: No.120, Lane 180, Hsin Ho Rd.
 Lung-Tan Dist., Tao Yuan City 325, Taiwan
 Date: 2023-03-15

Project Number. : 23LR0029 Temp.()/RH(%) : 23/51
 Test Mode : BT 3M Tx High ch Tested by : Barry Lee

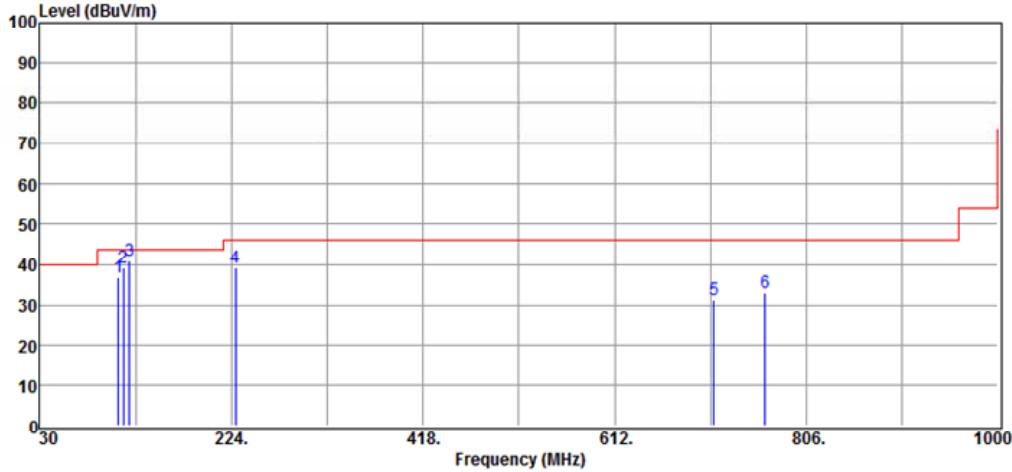

No	Freq MHz	Reading dBuV	Factor dB/m	Level dBuV/m	Limit dBuV/m	Margin dB	Remark	Pol V/H
1	109.54	45.74	-8.82	36.92	43.50	-6.58	Peak	HORIZONTAL
2	114.39	47.47	-8.47	39.00	43.50	-4.50	Peak	HORIZONTAL
3	121.18	48.78	-7.89	40.89	43.50	-2.61	Peak	HORIZONTAL
4	227.88	47.12	-7.91	39.21	46.00	-6.79	Peak	HORIZONTAL
5	712.88	28.01	3.39	31.40	46.00	-14.60	Peak	HORIZONTAL
6	764.29	28.23	4.64	32.87	46.00	-13.13	Peak	HORIZONTAL

Factor = AF + CL - AG

International Standard Laboratory Corp.
 Company Address: No.120, Lane 180, Hsin Ho Rd.
 Lung-Tan Dist., Tao Yuan City 325, Taiwan
 Date: 2023-03-15

Project Number. : 23LR0029 Temp.()/RH(%) : 23/51
 Test Mode : BT 1M Tx Hopping Tested by : Barry Lee

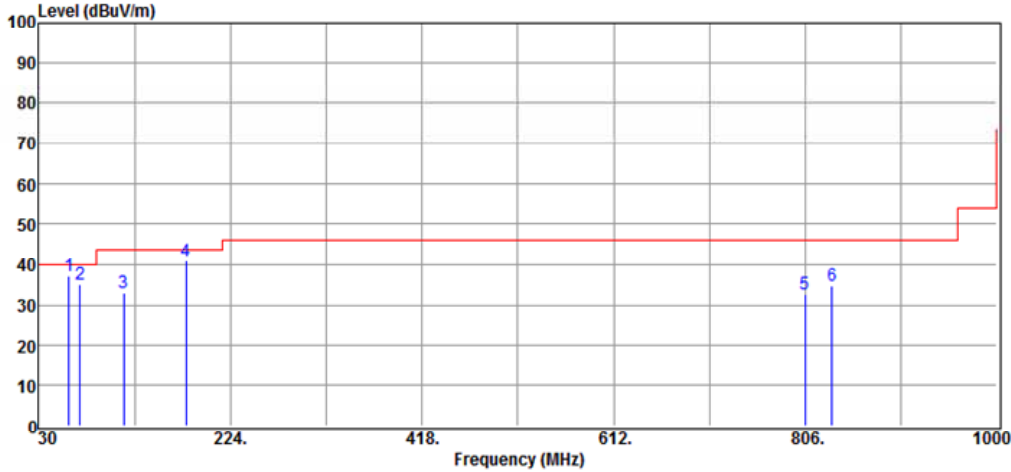

No	Freq MHz	Reading dBuV	Factor dB/m	Level dBuV/m	Limit dBuV/m	Margin dB	Remark	Pol V/H
1	61.04	43.57	-6.44	37.13	40.00	-2.87	Peak	VERTICAL
2	71.71	43.27	-8.16	35.11	40.00	-4.89	Peak	VERTICAL
3	116.33	41.54	-8.39	33.15	43.50	-10.35	Peak	VERTICAL
4	179.38	47.08	-6.33	40.75	43.50	-2.75	Peak	VERTICAL
5	806.00	27.70	5.03	32.73	46.00	-13.27	Peak	VERTICAL
6	833.16	29.37	5.41	34.78	46.00	-11.22	Peak	VERTICAL

Factor = AF + CL - AG

International Standard Laboratory Corp.
 Company Address: No.120, Lane 180, Hsin Ho Rd.
 Lung-Tan Dist., Tao Yuan City 325, Taiwan
 Date: 2023-03-15

Project Number. : 23LR0029 Temp.()/RH(%) : 23/51
 Test Mode : BT 1M Tx Hopping Tested by : Barry Lee

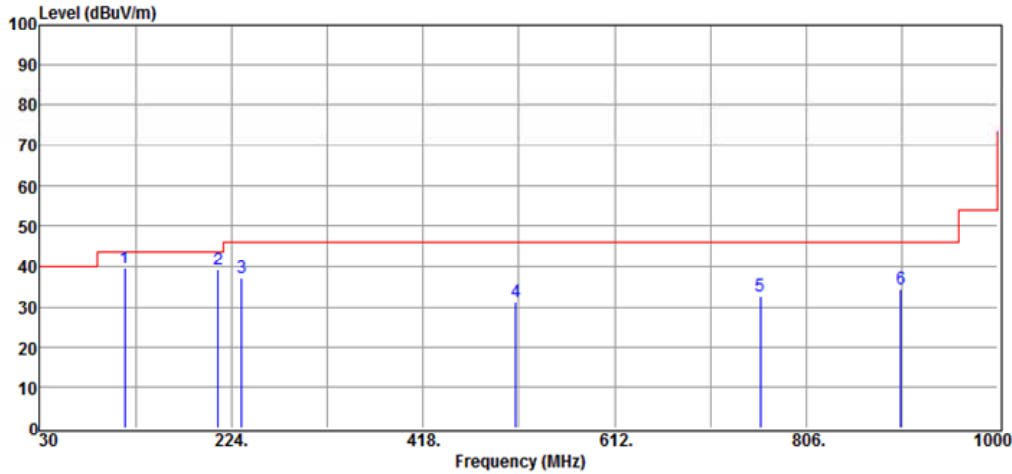

No	Freq MHz	Reading dBuV	Factor dB/m	Level dBuV/m	Limit dBuV/m	Margin dB	Remark	Pol V/H
1	116.33	48.05	-8.39	39.66	43.50	-3.84	Peak	HORIZONTAL
2	210.42	47.20	-7.87	39.33	43.50	-4.17	Peak	HORIZONTAL
3	234.67	44.17	-6.90	37.27	46.00	-8.73	Peak	HORIZONTAL
4	512.09	31.43	-0.29	31.14	46.00	-14.86	Peak	HORIZONTAL
5	759.44	27.88	4.61	32.49	46.00	-13.51	Peak	HORIZONTAL
6	902.03	27.82	6.47	34.29	46.00	-11.71	Peak	HORIZONTAL

Factor = AF + CL - AG

International Standard Laboratory Corp.
Company Address: No.120, Lane 180, Hsin Ho Rd.
Lung-Tan Dist., Tao Yuan City 325, Taiwan
Date: 2023-03-15

Project Number. : 23LR0029 Temp.()/RH(%) : 23/51
Test Mode : BT 2M Tx Hopping Tested by : Barry Lee

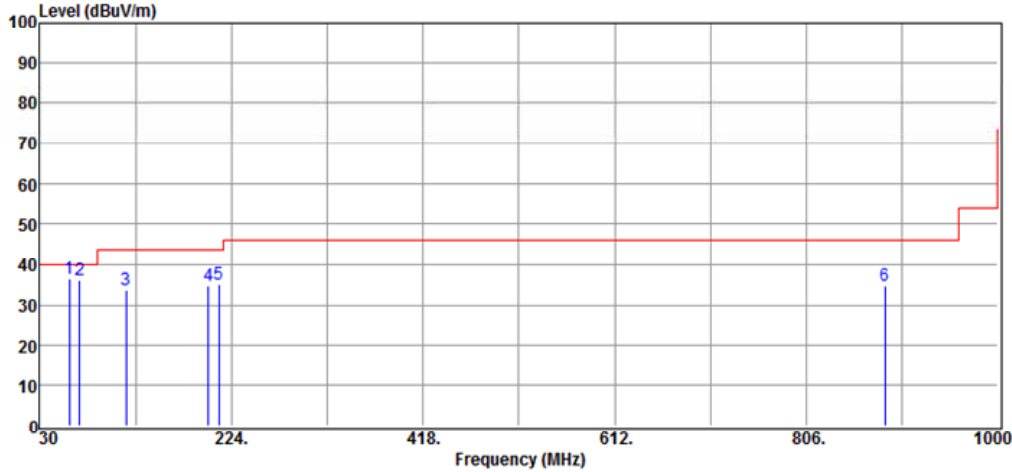

No	Freq MHz	Reading dBuV	Factor dB/m	Level dBuV/m	Limit dBuV/m	Margin dB	Remark	Pol V/H
1	60.07	42.65	-6.08	36.57	40.00	-3.43	Peak	VERTICAL
2	70.74	44.29	-8.06	36.23	40.00	-3.77	Peak	VERTICAL
3	117.30	41.89	-8.17	33.72	43.50	-9.78	Peak	VERTICAL
4	200.72	42.79	-7.96	34.83	43.50	-8.67	Peak	VERTICAL
5	211.39	42.97	-7.85	35.12	43.50	-8.38	Peak	VERTICAL
6	885.54	28.90	5.95	34.85	46.00	-11.15	Peak	VERTICAL

Factor = AF + CL - AG

International Standard Laboratory Corp.
 Company Address: No.120, Lane 180, Hsin Ho Rd.
 Lung-Tan Dist., Tao Yuan City 325, Taiwan
 Date: 2023-03-15

Project Number. : 23LR0029 Temp.()/RH(%) : 23/51
 Test Mode : BT 2M Tx Hopping Tested by : Barry Lee

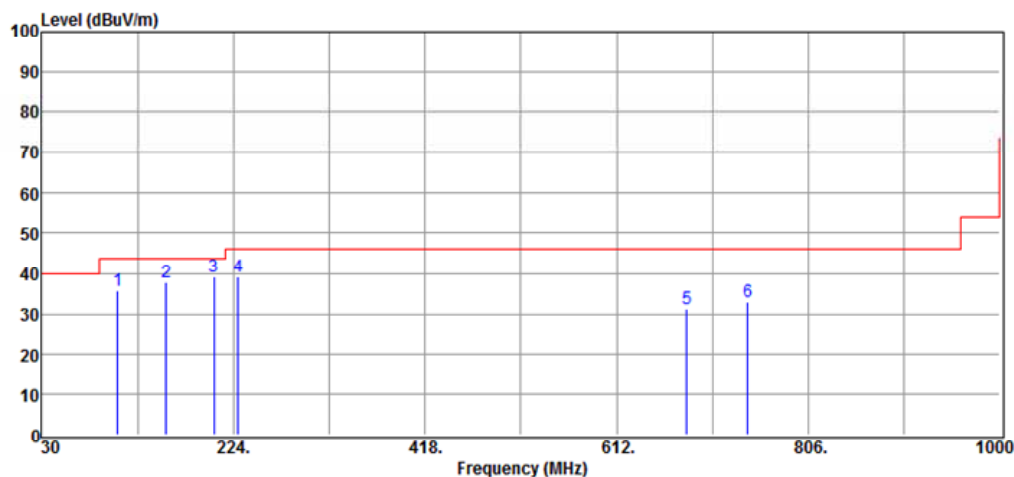

No	Freq MHz	Reading dBuV	Factor dB/m	Level dBuV/m	Limit dBuV/m	Margin dB	Remark	Pol V/H
1	106.63	45.00	-9.18	35.82	43.50	-7.68	Peak	HORIZONTAL
2	156.10	42.83	-5.00	37.83	43.50	-5.67	Peak	HORIZONTAL
3	204.60	47.31	-8.01	39.30	43.50	-4.20	Peak	HORIZONTAL
4	228.85	47.14	-7.85	39.29	46.00	-6.71	Peak	HORIZONTAL
5	682.81	28.33	2.98	31.31	46.00	-14.69	Peak	HORIZONTAL
6	744.89	28.48	4.34	32.82	46.00	-13.18	Peak	HORIZONTAL

Factor = AF + CL - AG

International Standard Laboratory Corp.
Company Address: No.120, Lane 180, Hsin Ho Rd.
Lung-Tan Dist., Tao Yuan City 325, Taiwan
Date: 2023-03-15

Project Number. : 23LR0029 Temp.()/RH(%) : 23/51
Test Mode : BT 3M Tx Hopping Tested by : Barry Lee

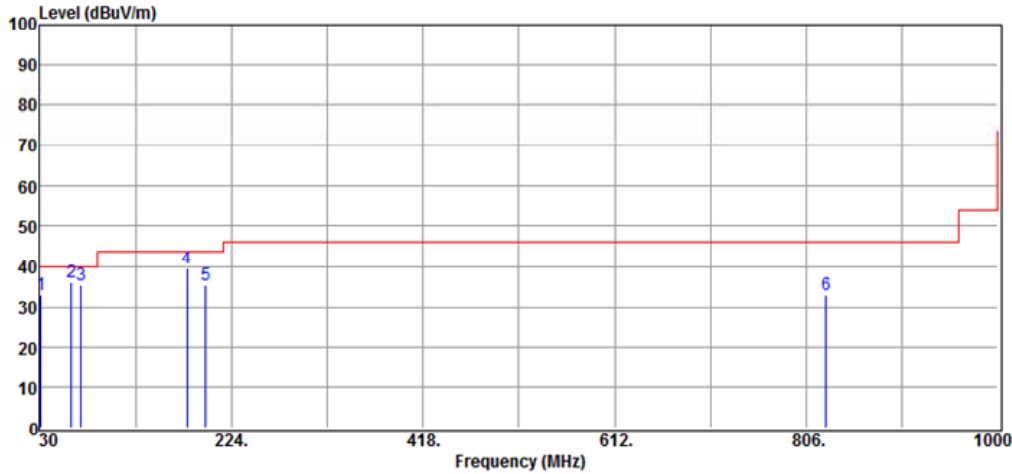

No	Freq MHz	Reading dBuV	Factor dB/m	Level dBuV/m	Limit dBuV/m	Margin dB	Remark	Pol V/H
1	30.97	40.28	-7.20	33.08	40.00	-6.92	Peak	VERTICAL
2	62.01	42.66	-6.62	36.04	40.00	-3.96	Peak	VERTICAL
3	71.71	43.58	-8.16	35.42	40.00	-4.58	Peak	VERTICAL
4	179.38	45.85	-6.33	39.52	43.50	-3.98	Peak	VERTICAL
5	197.81	43.22	-7.97	35.25	43.50	-8.25	Peak	VERTICAL
6	826.37	27.87	5.25	33.12	46.00	-12.88	Peak	VERTICAL

Factor = AF + CL - AG

International Standard Laboratory Corp.
 Company Address: No.120, Lane 180, Hsin Ho Rd.
 Lung-Tan Dist., Tao Yuan City 325, Taiwan
 Date: 2023-03-15

Project Number. : 23LR0029 Temp.()/RH(%) : 23/51
 Test Mode : BT 3M Tx Hopping Tested by : Barry Lee

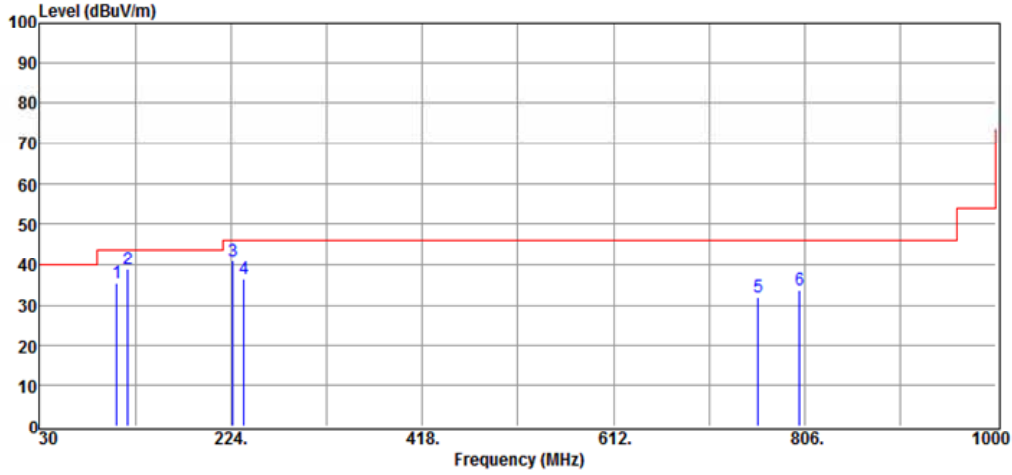

No	Freq MHz	Reading dBuV	Factor dB/m	Level dBuV/m	Limit dBuV/m	Margin dB	Remark	Pol V/H
1	108.57	44.50	-8.96	35.54	43.50	-7.96	Peak	HORIZONTAL
2	119.24	46.84	-8.03	38.81	43.50	-4.69	Peak	HORIZONTAL
3	225.94	48.88	-8.03	40.85	46.00	-5.15	Peak	HORIZONTAL
4	237.58	43.19	-6.61	36.58	46.00	-9.42	Peak	HORIZONTAL
5	758.47	27.43	4.58	32.01	46.00	-13.99	Peak	HORIZONTAL
6	801.15	28.45	5.08	33.53	46.00	-12.47	Peak	HORIZONTAL

Factor = AF + CL - AG

7.4.3 Radiated Spurious Emission Measurement Result (above 1GHz)



International Standard Laboratory Corp.
 Company Address: No. 120, Lane 180, Hsin-Ho Rd.
 Lung-Tan Dist., Tao-Yuan City 325, Taiwan
 Date: 2023-03-15

Project Number.: 23LR0029 → Temp.(°C)/RH(%) →: 23/51 →
 Test Mode → : 1M-Tx-Low ch → Tested by → : Barry-Lee →

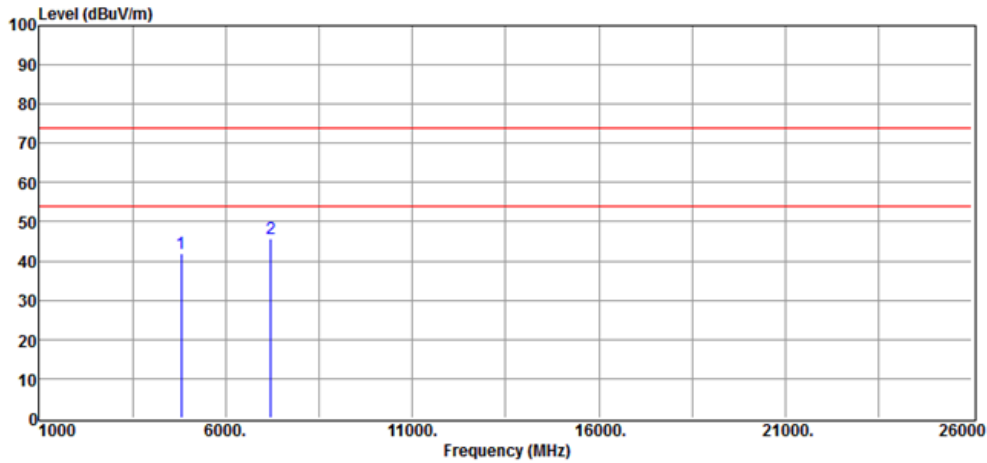

No.	Freq. MHz	Reading dBuV	Factor dB/m	Level dBuV/m	Limit dBuV/m	Margin dB	Remark	Pol. V/H
1	4804.00	34.40	7.38	41.78	74.00	-32.22	Peak	VERTICAL
2	4804.00	34.40	7.38	41.78	54.00(AV)	-12.22	Peak	VERTICAL
3	7206.00	35.28	10.27	45.55	74.00	-28.45	Peak	VERTICAL
4	7206.00	35.28	10.27	45.55	54.00(AV)	-8.45	Peak	VERTICAL

Factor = AF + CL - AG



International Standard Laboratory Corp.
Company Address: No. 120, Lane 180, Hsin Ho Rd.
Lung-Tan Dist., Tao Yuan City 325, Taiwan

Date: 2023-03-15

Project Number.: 23LR0029 → Temp.(°C)/RH(%)→: 23/51 →
Test Mode → : 1M Tx Low ch → Tested by → : Barry Lee →

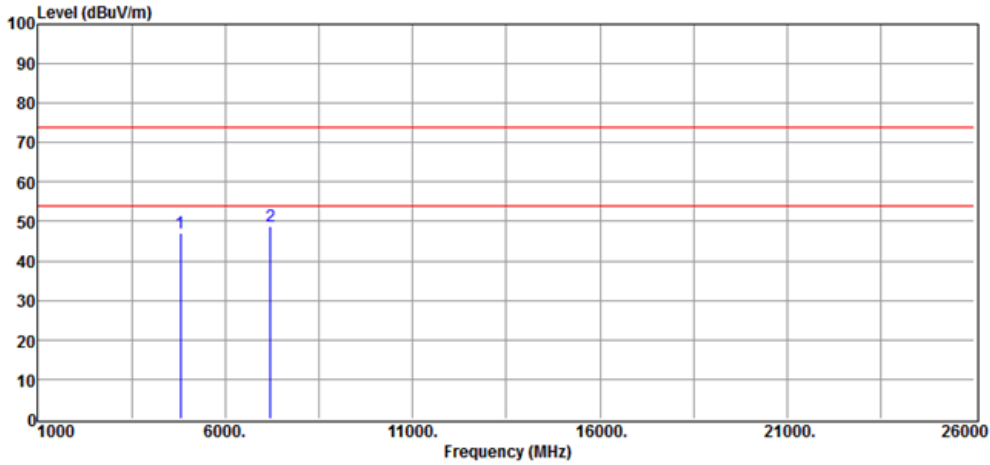

No	Freq MHz	Reading dBuV	Factor dB/m	Level dBuV/m	Limit dBuV/m	Margin dB	Remark	Pol V/H
1	4804.00	39.85	7.38	47.23	74.00	-26.77	Peak	HORIZONTAL
2	4804.00	39.85	7.38	47.23	54.00(AV)	-6.77	Peak	HORIZONTAL
3	7206.00	38.39	10.27	48.66	74.00	-25.34	Peak	HORIZONTAL
4	7206.00	38.39	10.27	48.66	54.00(AV)	-5.34	Peak	HORIZONTAL

Factor = AF + CL - AG



International Standard Laboratory Corp.
Company Address: No. 120, Lane 180, Hsin Ho Rd.
Lung-Tan Dist., Tao-Yuan City 325, Taiwan

Date: 2023-03-15

Project Number: 23LR0029 → Temp.(°C)/RH(%) → 23/51 →
Test Mode → : 1M Tx Mid ch → Tested by → : Barry Lee →

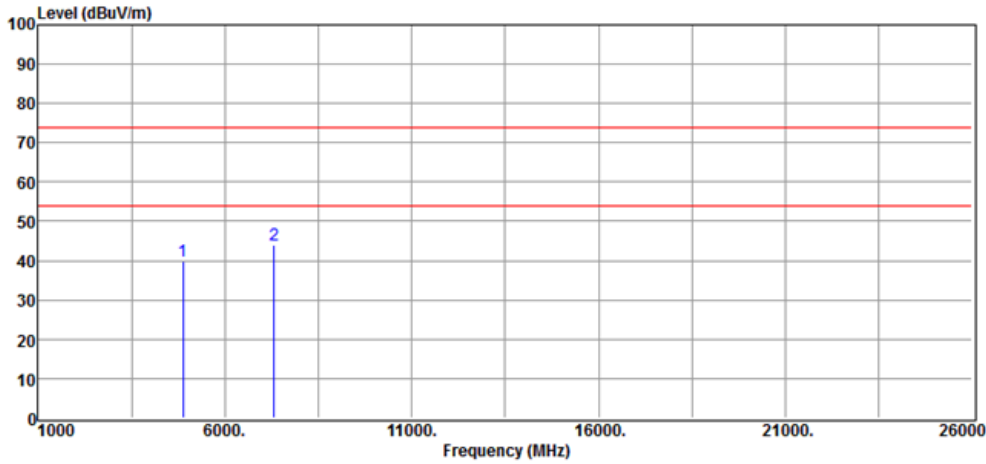

No	Freq MHz	Reading dBuV	Factor dB/m	Level dBuV/m	Limit dBuV/m	Margin dB	Remark	Pol V/H
1	4882.00	32.36	7.45	39.81	74.00	-34.19	Peak	VERTICAL
2	4882.00	32.36	7.45	39.81	54.00(AV)	-14.19	Peak	VERTICAL
3	7323.00	33.37	10.47	43.84	74.00	-30.16	Peak	VERTICAL
4	7323.00	33.37	10.47	43.84	54.00(AV)	-10.16	Peak	VERTICAL

Factor = AF + CL - AG



International Standard Laboratory Corp.
 Company Address: No. 120, Lane 180, Hsin Ho Rd.
 Lung-Tan Dist., Tao-Yuan City 325, Taiwan
 Date: 2023-03-15

Project Number.: 23LR0029 → Temp.(°C)/RH(%) →: 23/51 →
 Test Mode → : 1M Tx Mid ch → Tested by → : Barry Lee →

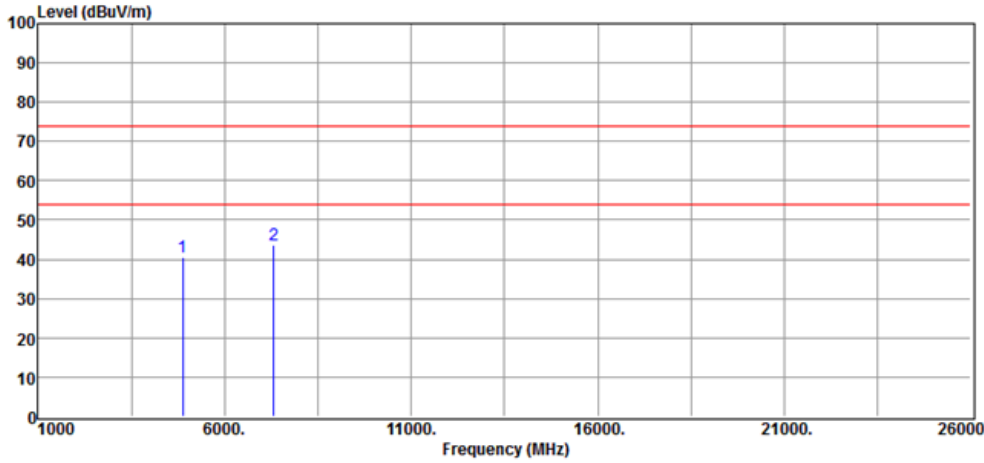

No.	Freq. MHz	Reading dBuV	Factor dB/m	Level dBuV/m	Limit dBuV/m	Margin dB	Remark	Pol V/H
1	4882.00	33.23	7.45	40.68	74.00	-33.32	Peak	HORIZONTAL
2	4882.00	33.23	7.45	40.68	54.00(AV)	-13.32	Peak	HORIZONTAL
3	7323.00	33.06	10.47	43.53	74.00	-30.47	Peak	HORIZONTAL
4	7323.00	33.06	10.47	43.53	54.00(AV)	-10.47	Peak	HORIZONTAL

Factor = AF + CL - AG



International Standard Laboratory Corp.
Company Address: No. 120, Lane 180, Hsin Ho Rd.
Lung-Tan Dist., Tao-Yuan City 325, Taiwan

Date: 2023-03-15

Project Number: 23LR0029 Temp.(°C)/RH(%) : 23/51
Test Mode : 1M Tx High ch Tested by : Barry Lee

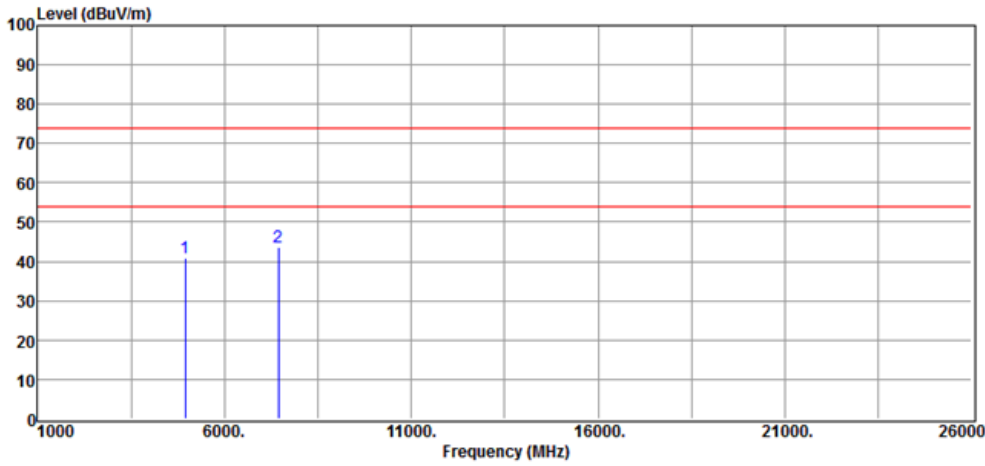

No	Freq MHz	Reading dBuV	Factor dB/m	Level dBuV/m	Limit dBuV/m	Margin dB	Remark	Pol V/H
1	4960.00	33.25	7.63	40.88	74.00	-33.12	Peak	VERTICAL
2	4960.00	33.25	7.63	40.88	54.00(AV)	-13.12	Peak	VERTICAL
3	7440.00	33.09	10.49	43.58	74.00	-30.42	Peak	VERTICAL
4	7440.00	33.09	10.49	43.58	54.00(AV)	-10.42	Peak	VERTICAL

Factor = AF + CL - AG



International Standard Laboratory Corp.
 Company Address: No. 120, Lane 180, Hsin Ho Rd.
 Lung-Tan Dist., Tao-Yuan City 325, Taiwan
 Date: 2023-03-15

Project Number.: 23LR0029 → Temp.(°C)/RH(%) →: 23/51 →
 Test Mode → : 1M Tx High ch → Tested by → : Barry Lee →

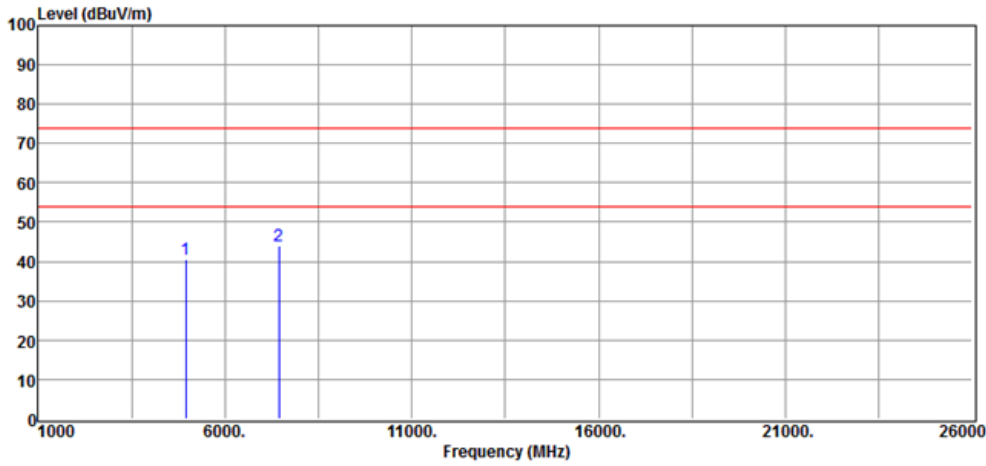

No.	Freq. MHz	Reading dBuV	Factor dB/m	Level dBuV/m	Limit dBuV/m	Margin dB	Remark	Pol V/H
1	4960.00	33.07	7.63	40.70	74.00	-33.30	Peak	HORIZONTAL
2	4960.00	33.07	7.63	40.70	54.00(AV)	-13.3	Peak	HORIZONTAL
3	7440.00	33.53	10.49	44.02	74.00	-29.98	Peak	HORIZONTAL
4	7440.00	33.53	10.49	44.02	54.00(AV)	-9.98	Peak	HORIZONTAL

Factor = AF + CL - AG



International Standard Laboratory Corp.
Company Address: No. 120, Lane 180, Hsin-Ho Rd.
Lung-Tan Dist., Tao-Yuan City 325, Taiwan

Date: 2023-03-15

Project Number.: 23LR0029 → Temp.(°C)/RH(%) →: 23/51 →
Test Mode → : 2M-Tx-Low-ch → Tested-by → : Barry-Lee →

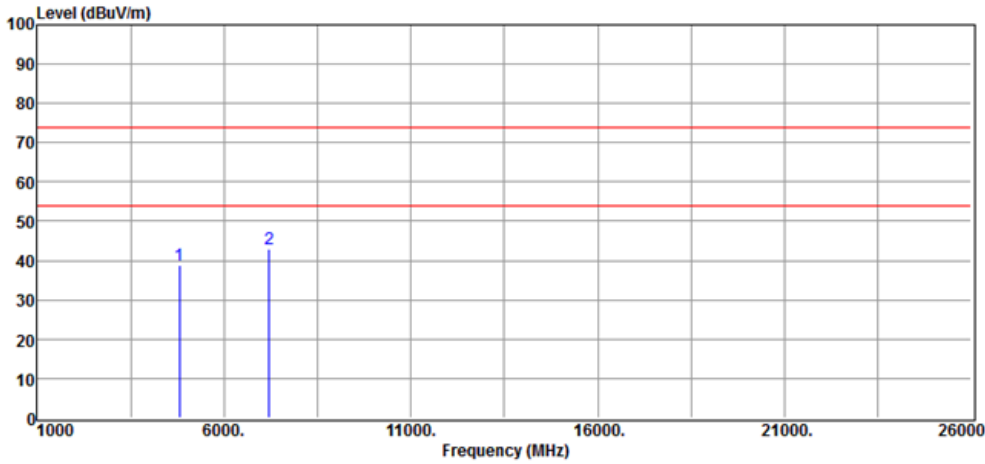

No.	Freq. MHz	Reading dBuV	Factor dB/m	Level dBuV/m	Limit dBuV/m	Margin dB	Remark	Pol. V/H
1	4804.00	31.58	7.38	38.96	74.00	-35.04	Peak	VERTICAL
2	4804.00	31.58	7.38	38.96	54.00(AV)	-15.04	Peak	VERTICAL
3	7206.00	32.57	10.27	42.84	74.00	-31.16	Peak	VERTICAL
4	7206.00	32.57	10.27	42.84	54.00(AV)	-11.16	Peak	VERTICAL

Factor = AF + CL - AG



International Standard Laboratory Corp.
 Company Address: No. 120, Lane 180, Hsin Ho Rd.
 Lung-Tan Dist., Tao-Yuan City 325, Taiwan

Date: 2023-03-15

Project Number.: 23LR0029 → Temp.(°C)/RH(%) →: 23/51 →
 Test Mode → : 2M-Tx Low ch → Tested by → : Barry Lee →

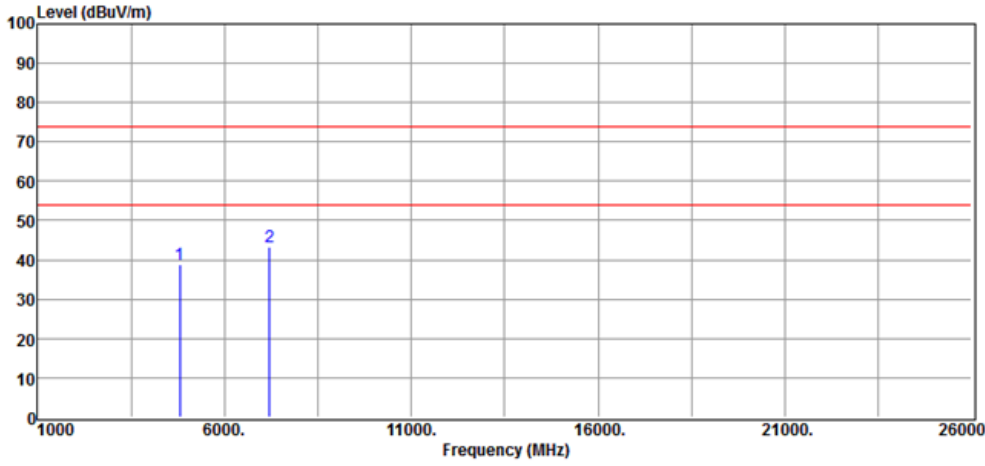

No.	Freq. MHz	Reading dBuV	Factor dB/m	Level dBuV/m	Limit dBuV/m	Margin dB	Remark	Pol V/H
1	4804.00	31.60	7.38	38.98	74.00	-35.02	Peak	HORIZONTAL
2	4804.00	31.60	7.38	38.98	54.00(AV)	-15.02	Peak	HORIZONTAL
3	7206.00	32.88	10.27	43.15	74.00	-30.85	Peak	HORIZONTAL
4	7206.00	32.88	10.27	43.15	54.00(AV)	-10.85	Peak	HORIZONTAL

Factor = AF + CL - AG



International Standard Laboratory Corp.
 Company Address: No. 120, Lane 180, Hsin Ho Rd.
 Lung-Tan Dist., Tao-Yuan City 325, Taiwan
 Date: 2023-03-15

Project Number.: 23LR0029 → Temp.(°C)/RH(%) →: 23/51 →
 Test Mode → : 2M-Tx-Mid-ch → Tested by → : Barry Lee →

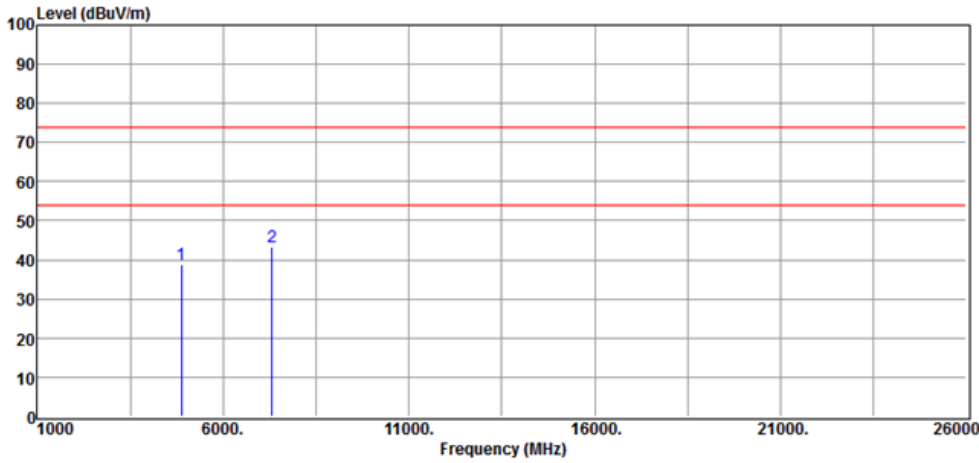

No	Freq MHz	Reading dBuV	Factor dB/m	Level dBuV/m	Limit dBuV/m	Margin dB	Remark	Pol V/H
1	4882.00	31.42	7.45	38.87	74.00	-35.13	Peak	VERTICAL
2	4882.00	31.42	7.45	38.87	54.00(AV)	-15.13	Peak	VERTICAL
3	7323.00	32.68	10.47	43.15	74.00	-30.85	Peak	VERTICAL
4	7323.00	32.68	10.47	43.15	54.00(AV)	-10.85	Peak	VERTICAL

Factor = AF + CL - AG



International Standard Laboratory Corp.
Company Address: No. 120, Lane 180, Hsin Ho Rd.
Lung-Tan Dist., Tao Yuan City 325, Taiwan

Date: 2023-03-15

Project Number: 23LR0029 → Temp.(°C)/RH(%) → 23/51 →
Test Mode → 2M-Tx-Mid-ch → Tested by → Barry-Lee →

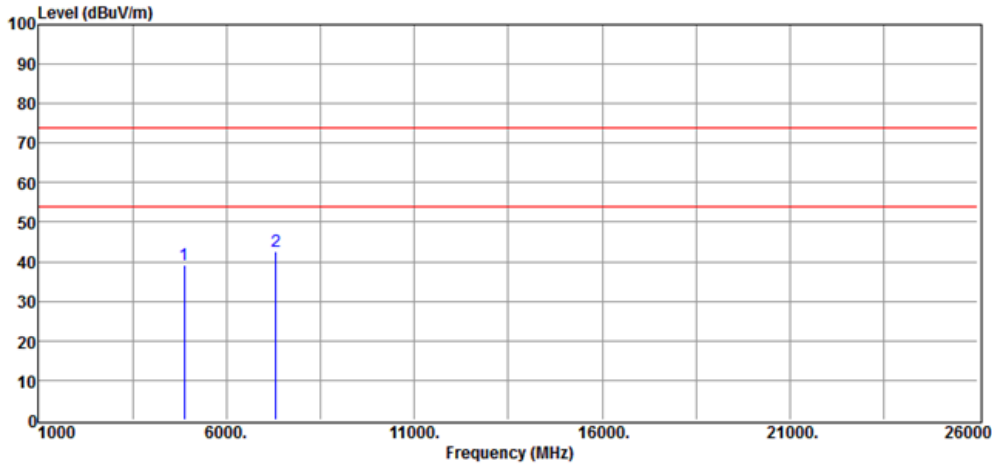

No	Freq MHz	Reading dBuV	Factor dB/m	Level dBuV/m	Limit dBuV/m	Margin dB	Remark	Pol V/H
1	4882.00	31.65	7.45	39.10	74.00	-34.90	Peak	HORIZONTAL
2	4882.00	31.65	7.45	39.10	54.00(AV)	-14.9	Peak	HORIZONTAL
3	7323.00	32.31	10.47	42.78	74.00	-31.22	Peak	HORIZONTAL
4	7323.00	32.31	10.47	42.78	54.00(AV)	-11.22	Peak	HORIZONTAL

Factor = AF + CL - AG



International Standard Laboratory Corp.
 Company Address: No. 120, Lane 180, Hsin-Ho Rd.
 Lung-Tan Dist., Tao-Yuan City 325, Taiwan
 Date: 2023-03-15

Project Number. → : 23LR0029 → Temp.(°C)/RH(%) → : 23/51 →
 Test Mode → : 2M Tx High ch → Tested by → : Barry Lee →

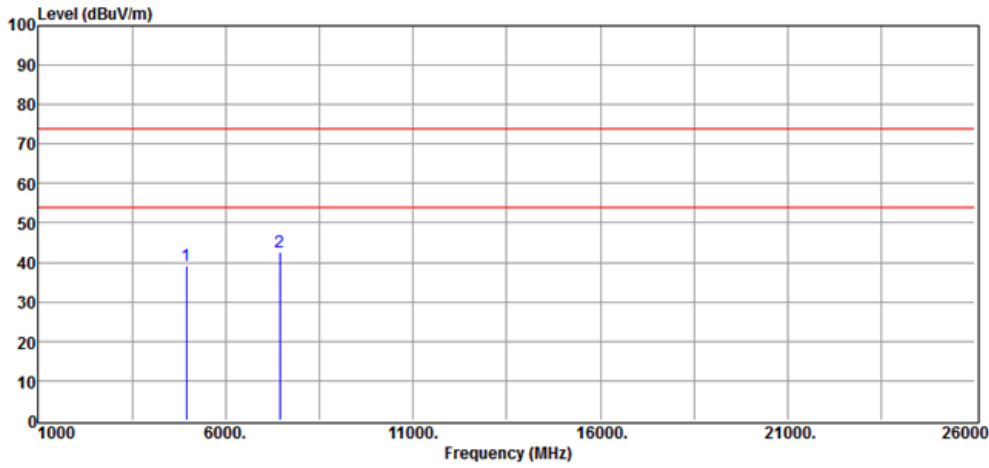

No	Freq MHz	Reading dBuV	Factor dB/m	Level dBuV/m	Limit dBuV/m	Margin dB	Remark	Pol V/H
1	4960.00	31.46	7.63	39.09	74.00	-34.91	Peak	VERTICAL
2	4960.00	31.46	7.63	39.09	54.00(AV)	-14.91	Peak	VERTICAL
3	7440.00	32.25	10.49	42.74	74.00	-31.26	Peak	VERTICAL
4	7440.00	32.25	10.49	42.74	54.00(AV)	-11.26	Peak	VERTICAL

Factor = AF + CL - AG



International Standard Laboratory Corp.
Company Address: No. 120, Lane 180, Hsin-Ho Rd.
Lung-Tan Dist., Tao-Yuan City 325, Taiwan

Date: 2023-03-15

Project Number: 23LR0029 → Temp.(°C)/RH(%) → 23/51 →
Test Mode → : 2M-Tx High ch → Tested by → : Barry Lee →

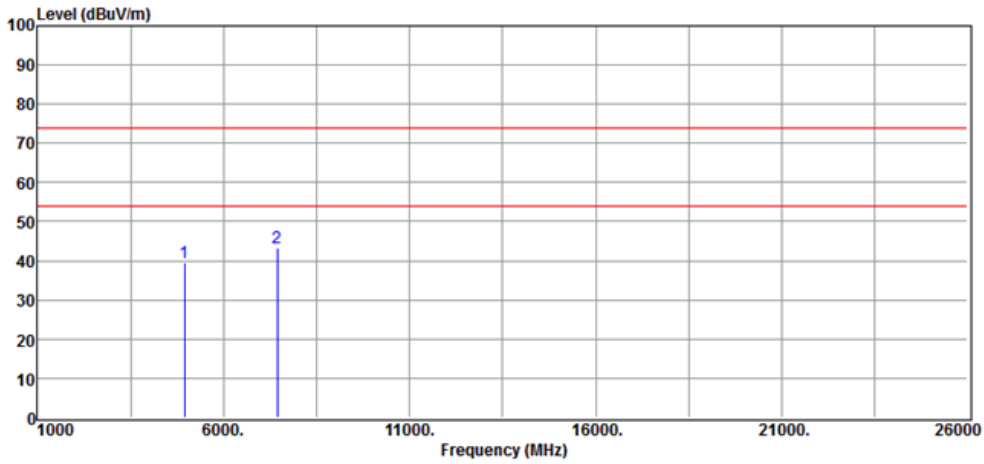

No	Freq MHz	Reading dBuV	Factor dB/m	Level dBuV/m	Limit dBuV/m	Margin dB	Remark	Pol V/H
1	4960.00	31.73	7.63	39.36	74.00	-34.64	Peak	HORIZONTAL
2	4960.00	31.73	7.63	39.36	54.00(AV)	-14.64	Peak	HORIZONTAL
3	7440.00	32.81	10.49	43.30	74.00	-30.70	Peak	HORIZONTAL
4	7440.00	32.81	10.49	43.30	54.00(AV)	-10.70	Peak	HORIZONTAL

Factor = AF + CL - AG



International Standard Laboratory Corp.
Company Address: No. 120, Lane 180, Hsin-Ho Rd.
Lung-Tan Dist., Tao-Yuan City 325, Taiwan

Date: 2023-03-15

Project Number.: 23LR0029 → Temp.(°C)/RH(%) →: 23/51 →
Test Mode → : 3M-Tx-Low-ch → Tested-by → : Barry Lee →

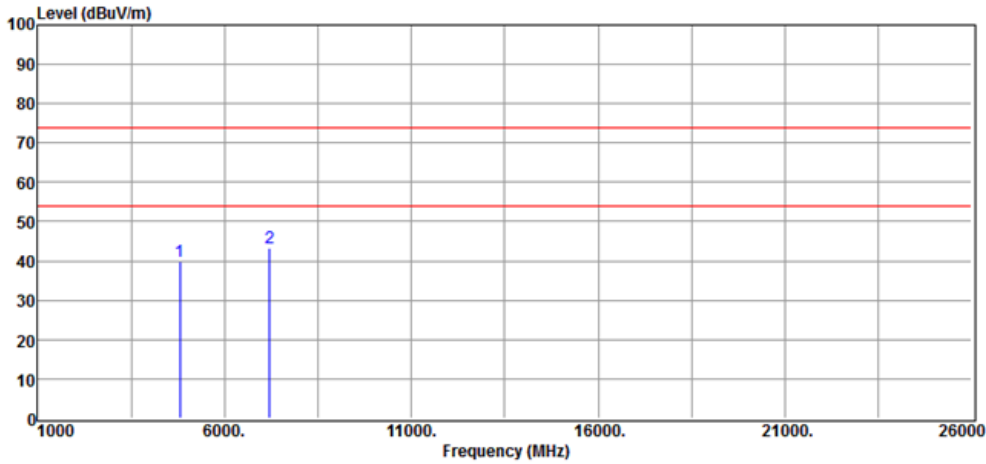

No.	Freq. MHz	Reading dBuV	Factor dB/m	Level dBuV/m	Limit dBuV/m	Margin dB	Remark	Pol. V/H
1	4804.00	32.65	7.38	40.03	74.00	-33.97	Peak	VERTICAL
2	4804.00	32.65	7.38	40.03	54.00(AV)	-13.97	Peak	VERTICAL
3	7206.00	32.97	10.27	43.24	74.00	-30.76	Peak	VERTICAL
4	7206.00	32.97	10.27	43.24	54.00(AV)	-10.76	Peak	VERTICAL

Factor = AF + CL - AG



International Standard Laboratory Corp.
Company Address: No. 120, Lane 180, Hsin Ho Rd.
Lung-Tan Dist., Tao Yuan City 325, Taiwan

Date: 2023-03-15

Project Number.: 23LR0029 → Temp.(°C)/RH(%) → 23/51 →
Test Mode → : 3M-Tx-Low-ch → Tested by → : Barry-Lee →

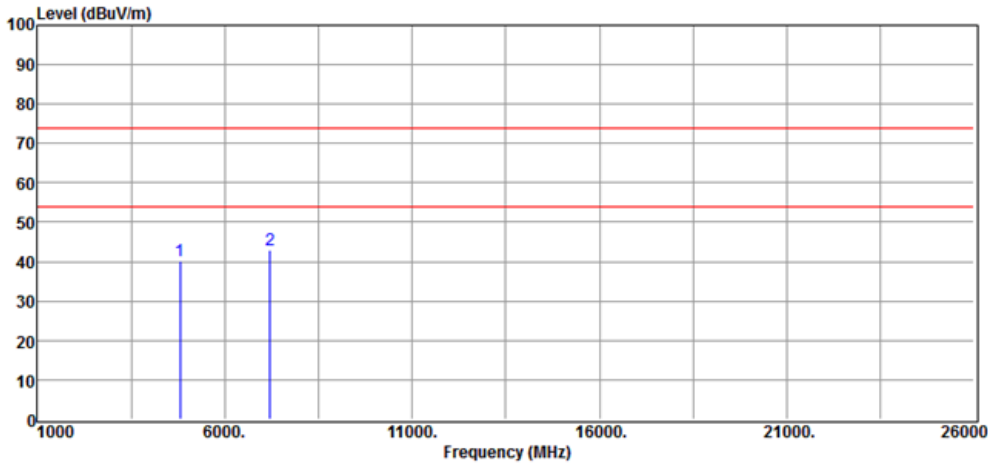

No	Freq MHz	Reading dBuV	Factor dB/m	Level dBuV/m	Limit dBuV/m	Margin dB	Remark	Pol V/H
1	4804.00	32.71	7.38	40.09	74.00	-33.91	Peak	HORIZONTAL
2	4804.00	32.71	7.38	40.09	54.00(AV)	-13.91	Peak	HORIZONTAL
3	7206.00	32.54	10.27	42.81	74.00	-31.19	Peak	HORIZONTAL
4	7206.00	32.54	10.27	42.81	54.00(AV)	-11.19	Peak	HORIZONTAL

Factor = AF + CL - AG



International Standard Laboratory Corp.
Company Address: No. 120, Lane 180, Hsin Ho Rd.
Lung-Tan Dist., Tao Yuan City 325, Taiwan

Date: 2023-03-15

Project Number: 23LR0029 → Temp.(°C)/RH(%) → 23/51 →
Test Mode → 3M-Tx-Mid.ch → Tested by → Barry Lee →

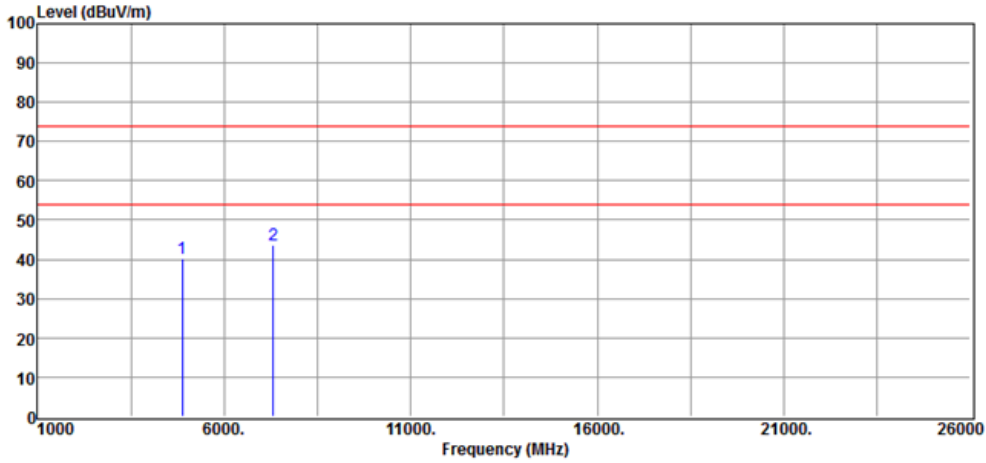

No	Freq MHz	Reading dBuV	Factor dB/m	Level dBuV/m	Limit dBuV/m	Margin dB	Remark	Pol V/H
1	4882.00	32.59	7.45	40.04	74.00	-33.96	Peak	VERTICAL
2	4882.00	32.59	7.45	40.04	54.00(AV)	-13.96	Peak	VERTICAL
3	7323.00	33.01	10.47	43.48	74.00	-30.52	Peak	VERTICAL
4	7323.00	33.01	10.47	43.48	54.00(AV)	-10.52	Peak	VERTICAL

Factor = AF + CL - AG



International Standard Laboratory Corp.
 Company Address: No. 120, Lane 180, Hsin Ho Rd.
 Lung-Tan Dist., Tao Yuan City 325, Taiwan

Date: 2023-03-15

Project Number: 23LR0029 Temp.(°C)/RH(%) : 23/51
 Test Mode : 3M Tx Mid ch Tested by : Barry Lee

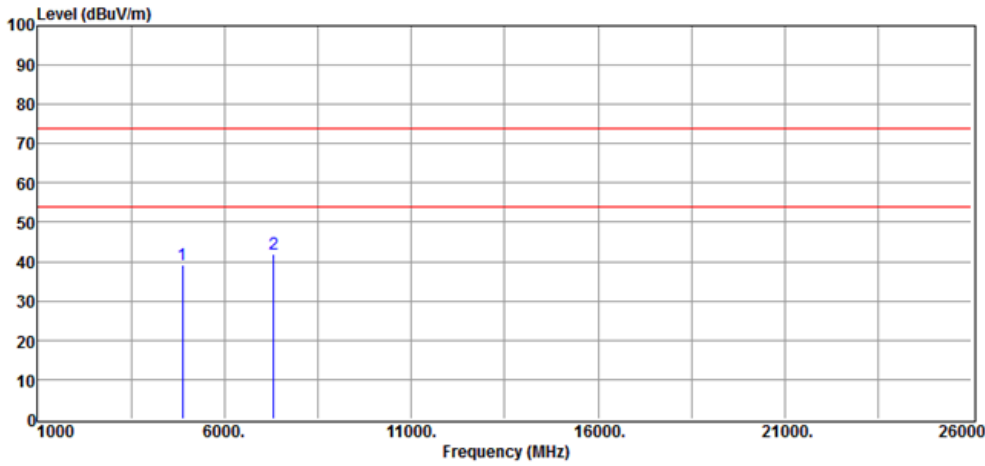

No	Freq MHz	Reading dBuV	Factor dB/m	Level dBuV/m	Limit dBuV/m	Margin dB	Remark	Pol V/H
1	4882.00	31.66	7.45	39.11	74.00	-34.89	Peak	HORIZONTAL
2	4882.00	31.66	7.45	39.11	54.00(AV)	-14.89	Peak	HORIZONTAL
3	7323.00	31.52	10.47	41.99	74.00	-32.01	Peak	HORIZONTAL
4	7323.00	31.52	10.47	41.99	54.00(AV)	-12.01	Peak	HORIZONTAL

Factor = AF + CL - AG



International Standard Laboratory Corp.
 Company Address: No. 120, Lane 180, Hsin-Ho Rd.
 Lung-Tan Dist., Tao-Yuan City 325, Taiwan
 Date: 2023-03-15

Project Number. → : 23LR0029 → Temp.(°C)/RH(%) → : 23/51 →
 Test Mode → : 3M Tx High ch → Tested by → : Barry Lee →

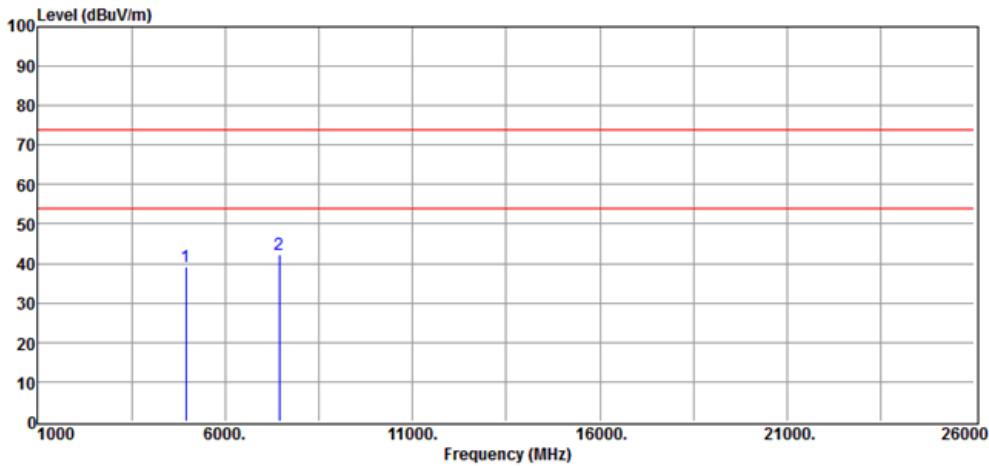

No	Freq MHz	Reading dBuV	Factor dB/m	Level dBuV/m	Limit dBuV/m	Margin dB	Remark	Pol V/H
1	4960.00	31.67	7.63	39.30	74.00	-34.70	Peak	VERTICAL
2	4960.00	31.67	7.63	39.30	54.00(AV)	-14.7	Peak	VERTICAL
3	7440.00	31.78	10.49	42.27	74.00	-31.73	Peak	VERTICAL
4	7440.00	31.78	10.49	42.27	54.00(AV)	-11.73	Peak	VERTICAL

Factor = AF + CL - AG



International Standard Laboratory Corp.
Company Address: No. 120, Lane 180, Hsin Ho Rd.
Lung-Tan Dist., Tao-Yuan City 325, Taiwan

Date: 2023-03-15

Project Number. → : 23LR0029 → Temp.(°C)/RH(%) → : 23/51 →
Test Mode → : 3M Tx High ch → Tested by → : Barry Lee →

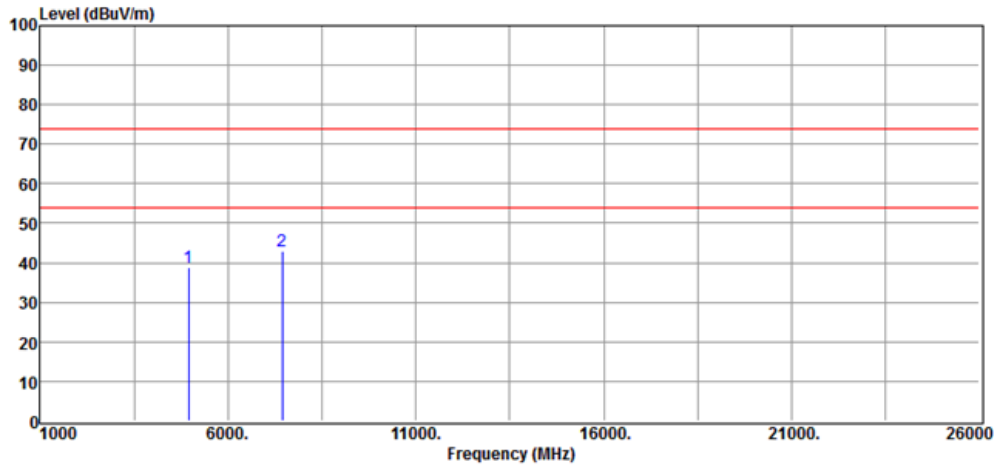

No	Freq MHz	Reading dBuV	Factor dB/m	Level dBuV/m	Limit dBuV/m	Margin dB	Remark	Pol V/H
1	4960.00	31.06	7.63	38.69	74.00	-35.31	Peak	HORIZONTAL
2	4960.00	31.06	7.63	38.69	54.00(AV)	-15.31	Peak	HORIZONTAL
3	7440.00	32.49	10.49	42.98	74.00	-31.02	Peak	HORIZONTAL
4	7440.00	32.49	10.49	42.98	54.00(AV)	-11.02	Peak	HORIZONTAL

Factor = AF + CL - AG



International Standard Laboratory Corp.
 Company Address: No. 120, Lane 180, Hsin-Ho Rd.
 Lung-Tan Dist., Tao Yuan City 325, Taiwan
 Date: 2023-03-15

Project Number: 23LR0029 → Temp.(°C)/RH(%) → 23/51 →
 Test Mode → 1M-Hopping → Tested by → Barry-Lee →

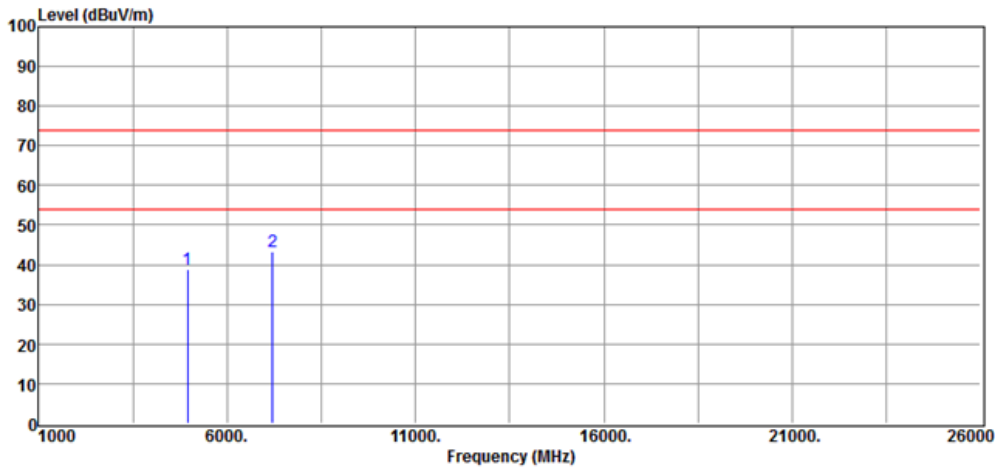

No	Freq MHz	Reading dBuV	Factor dB/m	Level dBuV/m	Limit dBuV/m	Margin dB	Remark	Pol V/H
1	4961.00	31.16	7.63	38.79	74.00	-35.21	Peak	VERTICAL
2	4961.00	31.16	7.63	38.79	54.00(AV)	-15.21	Peak	VERTICAL
3	7205.00	33.06	10.27	43.33	74.00	-30.67	Peak	VERTICAL
4	7205.00	33.06	10.27	43.33	54.00(AV)	-10.67	Peak	VERTICAL

Factor = AF + CL - AG



International Standard Laboratory Corp.
Company Address: No. 120, Lane 180, Hsin Ho Rd.
Lung-Tan Dist., Tao Yuan City 325, Taiwan

Date: 2023-03-15

Project Number: 23LR0029 → Temp.(°C)/RH(%) → 23/51 →
Test Mode → 1M Hoping → Tested by → Barry Lee →

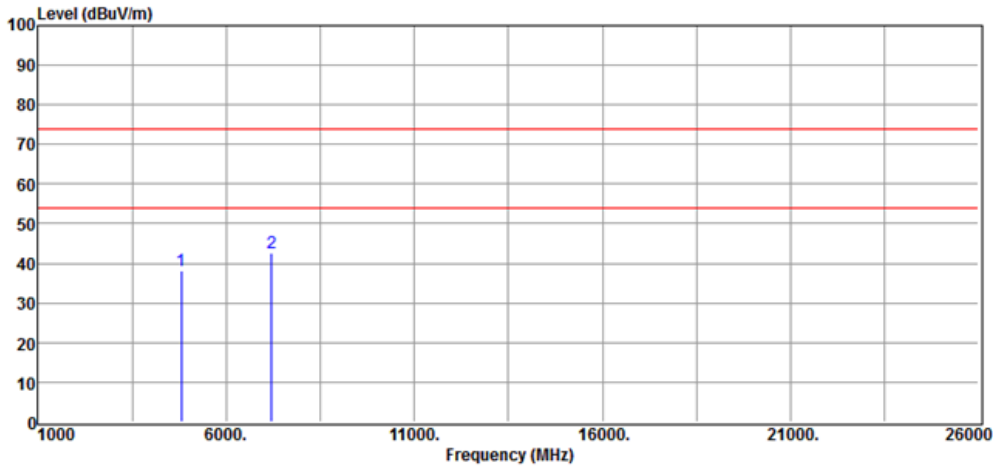

No.	Freq. MHz	Reading dBuV	Factor dB/m	Level dBuV/m	Limit dBuV/m	Margin dB	Remark	Pol V/H
1	4810.00	30.74	7.38	38.12	74.00	-35.88	Peak	HORIZONTAL
2	4810.00	30.74	7.38	38.12	54.00(AV)	-15.88	Peak	HORIZONTAL
3	7206.00	32.21	10.27	42.48	74.00	-31.52	Peak	HORIZONTAL
4	7206.00	32.21	10.27	42.48	54.00(AV)	-11.52	Peak	HORIZONTAL

Factor = AF + CL - AG



International Standard Laboratory Corp.
 Company Address: No. 120, Lane 180, Hsin-Ho Rd.
 Lung-Tan Dist., Tao-Yuan City 325, Taiwan
 Date: 2023-03-15

Project Number. → : 23LR0029 → Temp.(°C)/RH(%) → : 23/51 →
 Test Mode → : 2M-Hopping → Tested-by → : Barry Lee →

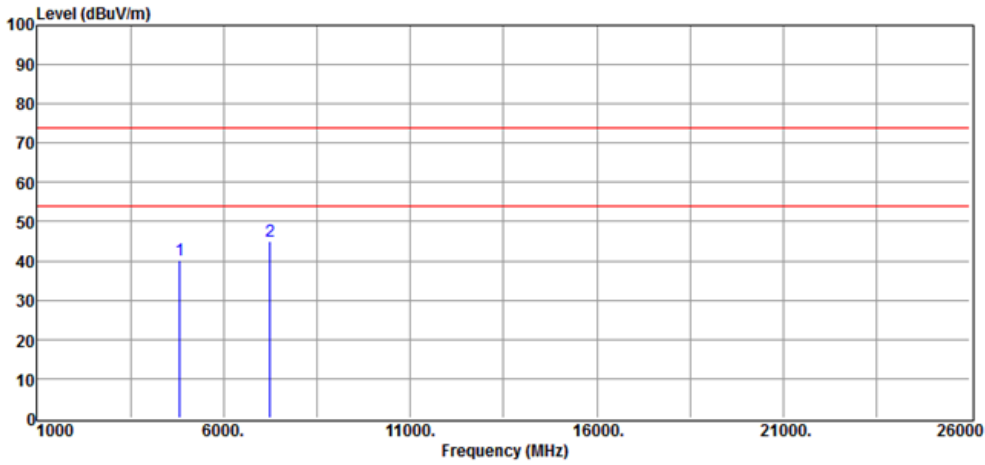

No	Freq MHz	Reading dBuV	Factor dB/m	Level dBuV/m	Limit dBuV/m	Margin dB	Remark	Pol V/H
1	4825.00	32.89	7.41	40.30	74.00	-33.70	Peak	VERTICAL
2	4825.00	32.89	7.41	40.30	54.00(AV)	-13.7	Peak	VERTICAL
3	7239.00	34.85	10.28	45.13	74.00	-28.87	Peak	VERTICAL
4	7239.00	34.85	10.28	45.13	54.00(AV)	-8.87	Peak	VERTICAL

Factor = AF + CL - AG



International Standard Laboratory Corp.
Company Address: No. 120, Lane 180, Hsin-Ho Rd.
Lung-Tan Dist., Tao-Yuan City 325, Taiwan

Date: 2023-03-15

Project Number.: 23LR0029 → Temp.(°C)/RH(%) →: 23/51 →
Test Mode → : 2M Hoping → Tested by → : Barry Lee →

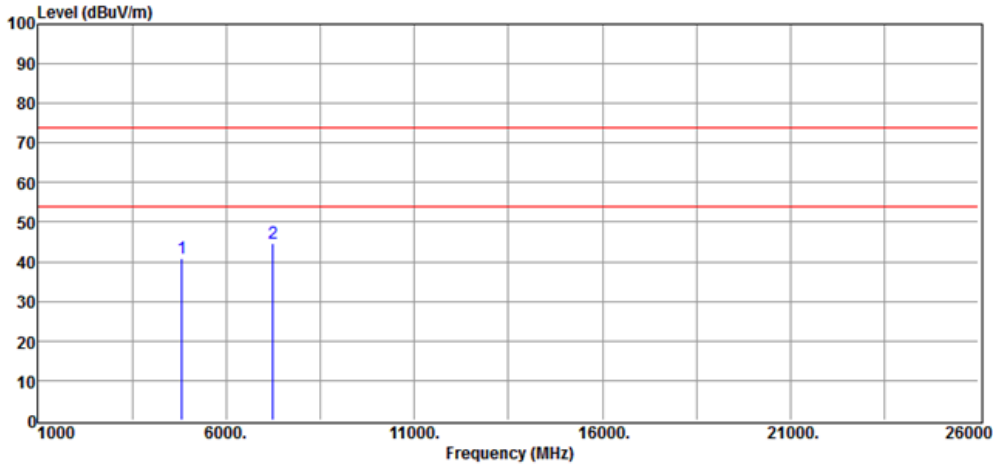

No.	Freq. MHz	Reading dBuV	Factor dB/m	Level dBuV/m	Limit dBuV/m	Margin dB	Remark	Pol V/H
1	4825.00	33.46	7.41	40.87	74.00	-33.13	Peak	HORIZONTAL
2	4825.00	33.46	7.41	40.87	54.00(AV)	-13.13	Peak	HORIZONTAL
3	7239.00	34.46	10.28	44.74	74.00	-29.26	Peak	HORIZONTAL
4	7239.00	34.46	10.28	44.74	54.00(AV)	-9.26	Peak	HORIZONTAL

Factor = AF + CL - AG



International Standard Laboratory Corp.
 Company Address: No. 120, Lane 180, Hsin Ho Rd.
 Lung-Tan Dist., Tao Yuan City 325, Taiwan
 Date: 2023-03-15

Project Number.: 23LR0029 → Temp.(°C)/RH(%) → : 23/51 →
 Test Mode → : 3M-Hopping → Tested by → : Barry-Lee →

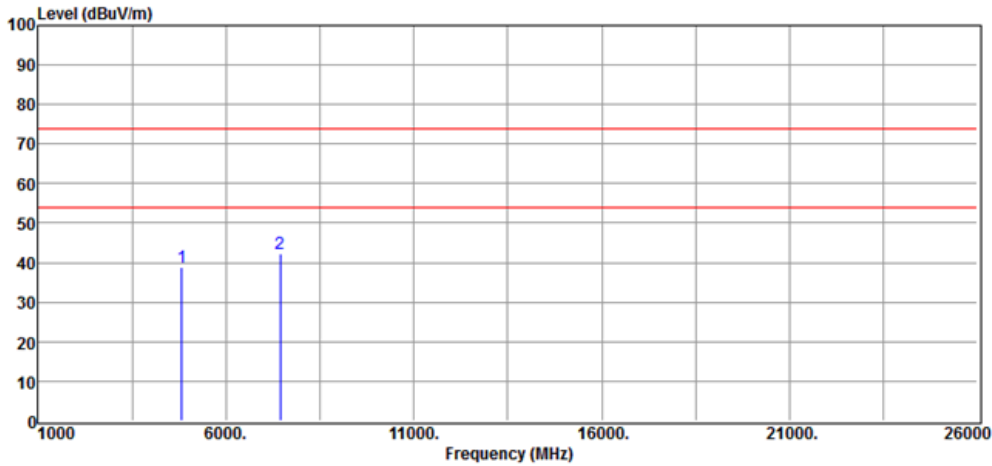

No.	Freq. MHz	Reading dBuV	Factor dB/m	Level dBuV/m	Limit dBuV/m	Margin dB	Remark	Pol. V/H
1	4827.00	31.40	7.41	38.81	74.00	-35.19	Peak	VERTICAL
2	4827.00	31.40	7.41	38.81	54.00(AV)	-15.19	Peak	VERTICAL
3	7443.00	31.70	10.48	42.18	74.00	-31.82	Peak	VERTICAL
4	7443.00	31.70	10.48	42.18	54.00(AV)	-11.82	Peak	VERTICAL

Factor = AF + CL - AG



International Standard Laboratory Corp.
Company Address: No. 120, Lane 180, Hsin-Ho Rd.
Lung-Tan Dist., Tao-Yuan City 325, Taiwan

Date: 2023-03-15

Project Number.: 23LR0029 → Temp.(°C)/RH(%) →: 23/51 →
Test Mode → : 3M-Hopping → Tested by → : Barry-Lee →

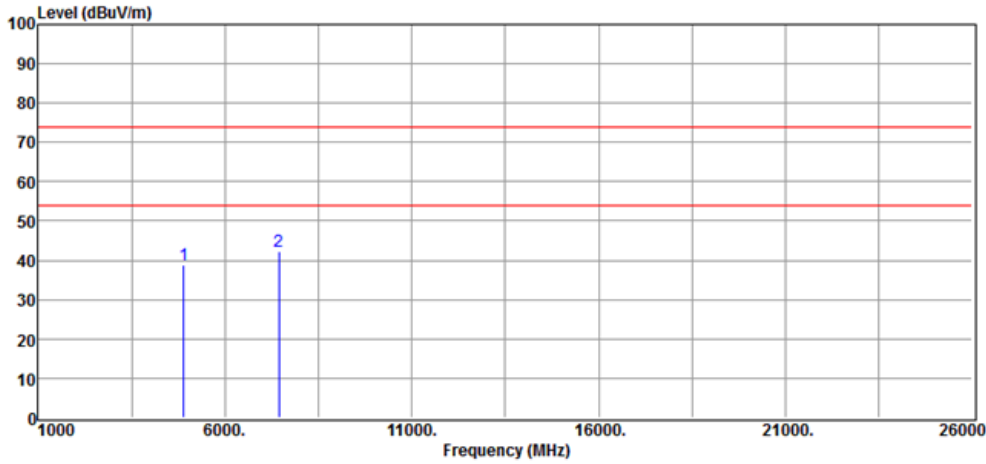

No.	Freq. MHz	Reading dBuV	Factor dB/m	Level dBuV/m	Limit dBuV/m	Margin dB	Remark	Pol. V/H
1	4893.00	31.51	7.46	38.97	74.00	-35.03	Peak	HORIZONTAL
2	4893.00	31.51	7.46	38.97	54.00(AV)	-15.03	Peak	HORIZONTAL
3	7437.00	31.74	10.49	42.23	74.00	-31.77	Peak	HORIZONTAL
4	7437.00	31.74	10.49	42.23	54.00(AV)	-11.77	Peak	HORIZONTAL

Factor = AF + CL - AG

8. 100kHz Bandwidth of Band Edges Measurement

8.1 Standard Applicable

According to §15.247(d), in any 100 kHz bandwidth outside the frequency bands in which the spread spectrum intentional radiator is operating, the radio frequency power that is produced by the intentional radiator shall be at least 20dB below that in the 100kHz bandwidth within the band that contains the highest level of the desired power, In addition, radiated emissions which fall in the restricted bands, as defined in §15.205(a), must also comply with the radiated emission limits specified in 15.209(a).

According to RSS-247 issue 2, §5.5

In any 100 kHz bandwidth outside the frequency band in which the spread spectrum or digitally modulated device is operating, the RF power that is produced shall be at least 20 dB below that in the 100 kHz bandwidth within the band that contains the highest level of the desired power, based on either an RF conducted or a radiated measurement, provided that the transmitter demonstrates compliance with the peak conducted power limits. If the transmitter complies with the conducted power limits based on the use of root-mean-square averaging over a time interval, as permitted under Section 5.4(d), the attenuation required shall be 30 dB instead of 20 dB. Attenuation below the general field strength limits specified in RSS-Gen is not required.

8.2 Measurement Procedure

1. Place the EUT on the table and set it in transmitting mode.
2. Remove the antenna from the EUT and then connect a low loss RF cable from the antenna port to the spectrum analyzer.
3. Set center frequency of spectrum analyzer = operating frequency.
4. Set the spectrum analyzer as RBW=1MHz, VBW≥3*RBW (for Peak); VBW≥1/T_{on} (for Average), Sweep = auto.
5. Mark Peak, 2.390GHz and 2.4835GHz and record the max. level.
6. Repeat above procedures until all frequency measured were complete.

8.3 Field Strength Calculation

The field strength is calculated by adding the Antenna Factor and Cable Factor and subtracting the Amplifier Gain and Duty Cycle Correction Factor (if any) from the measured reading. The basic equation with a sample calculation is as follows:

$$FS = RA + AF + CL - AG$$

Where	FS = Field Strength	CL = Cable Attenuation Factor (Cable Loss)
	RA = Reading Amplitude	AG = Amplifier Gain
	AF = Antenna Factor	

8.4 Measurement Result

International Standard Laboratory Corp.
 Company Address: No.120, Lane 180, Hsin Ho Rd.
 Lung-Tan Dist., Tao Yuan City 325, Taiwan

Date: 2023-03-15

Project Number. : 23LR0029 Temp.()/RH(%) : 23/51
 Test Mode : 1M bandedge Low ch Tested by : Barry Lee

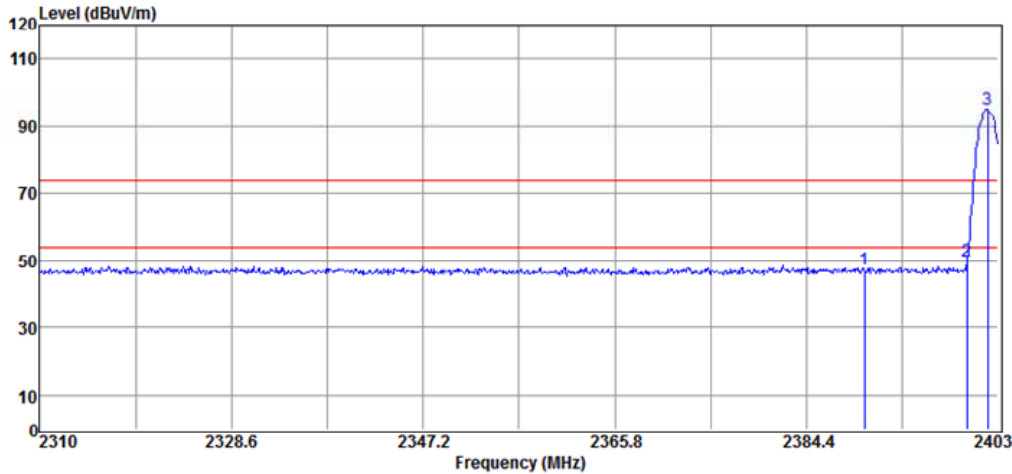

No	Freq MHz	Reading dBuV	Factor dB/m	Level dBuV/m	Limit dBuV/m	Margin dB	Remark	Pol V/H
1	2390.00	45.21	2.33	47.54	74.00	-26.46	Peak	VERTICAL
2	2400.00	47.69	2.41	50.10	74.90	-24.80	Peak	VERTICAL
3	2401.98	92.49	2.41	94.90	F	--	Peak	VERTICAL

Note: "F" denotes fundamental frequency.

International Standard Laboratory Corp.
 Company Address: No.120, Lane 180, Hsin Ho Rd.
 Lung-Tan Dist., Tao Yuan City 325, Taiwan
 Date: 2023-03-15

Project Number. : 23LR0029 Temp.()/RH(%) : 23/51
 Test Mode : 1M bandedge Low ch Tested by : Barry Lee

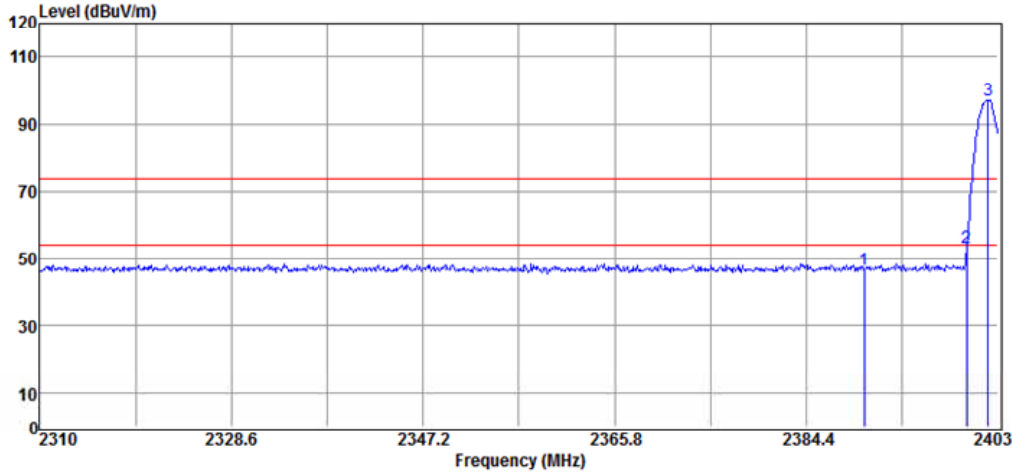

No	Freq MHz	Reading dBuV	Factor dB/m	Level dBuV/m	Limit dBuV/m	Margin dB	Remark	Pol V/H
1	2390.00	44.08	2.33	46.41	74.00	-27.59	Peak	HORIZONTAL
2	2400.00	50.87	2.41	53.28	77.00	-23.72	Peak	HORIZONTAL
3	2402.07	94.59	2.41	97.00	F	--	Peak	HORIZONTAL

Note: "F" denotes fundamental frequency.

International Standard Laboratory Corp.
Company Address: No.120, Lane 180, Hsin Ho Rd.
Lung-Tan Dist., Tao Yuan City 325, Taiwan
Date: 2023-03-15

Project Number. : 23LR0029 Temp.()/RH(%) : 23/51
Test Mode : 1M bandedge High ch Tested by : Barry Lee

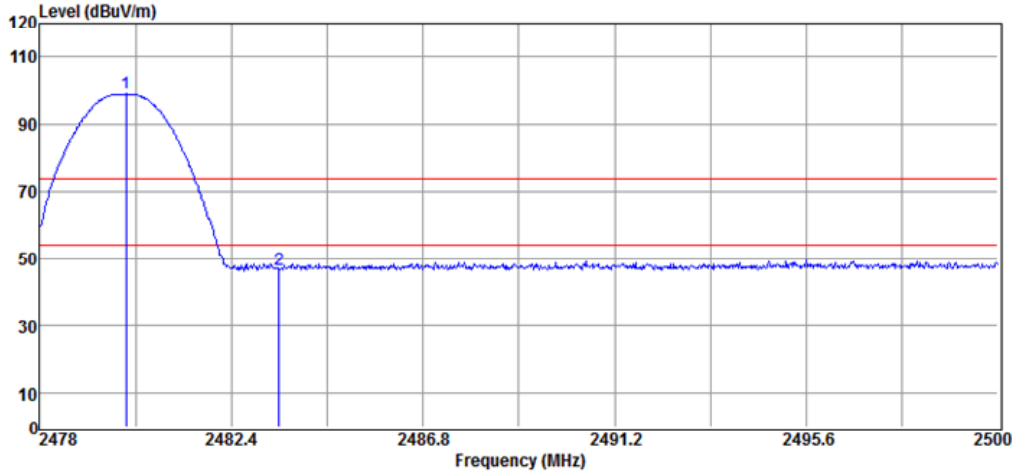

No	Freq MHz	Reading dBuV	Factor dB/m	Level dBuV/m	Limit dBuV/m	Margin dB	Remark	Pol V/H
1	2479.98	96.03	2.74	98.77	F	--	Peak	VERTICAL
2	2483.50	43.77	2.76	46.53	74.00	-27.47	Peak	VERTICAL

Note: "F" denotes fundamental frequency.

International Standard Laboratory Corp.
 Company Address: No.120, Lane 180, Hsin Ho Rd.
 Lung-Tan Dist., Tao Yuan City 325, Taiwan
 Date: 2023-03-15

Project Number. : 23LR0029 Temp.()/RH(%) : 23/51
 Test Mode : 1M bandedge High ch Tested by : Barry Lee

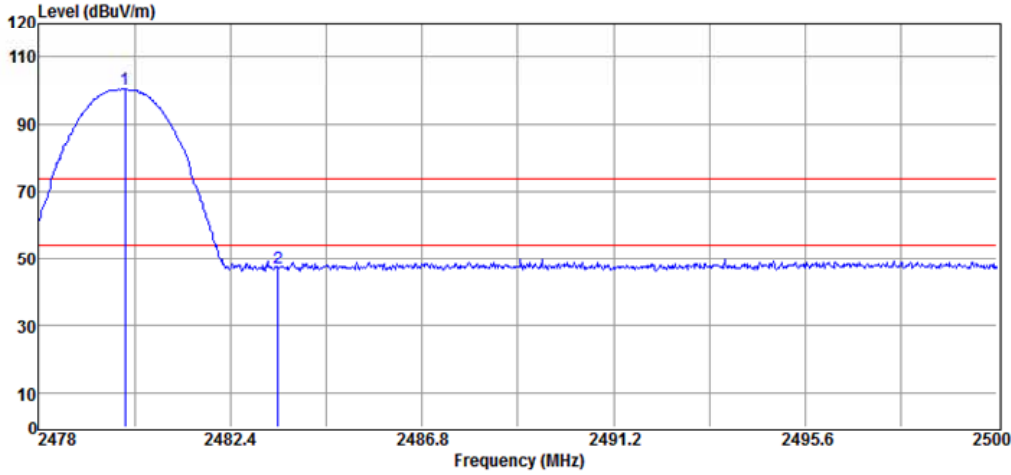

No	Freq MHz	Reading dBuV	Factor dB/m	Level dBuV/m	Limit dBuV/m	Margin dB	Remark	Pol V/H
1	2479.98	97.32	2.74	100.06	F	--	Peak	HORIZONTAL
2	2483.50	44.13	2.76	46.89	74.00	-27.11	Peak	HORIZONTAL

Note: "F" denotes fundamental frequency.

International Standard Laboratory Corp.
Company Address: No.120, Lane 180, Hsin Ho Rd.
Lung-Tan Dist., Tao Yuan City 325, Taiwan
Date: 2023-03-15

Project Number. : 23LR0029 Temp.()/RH(%) : 23/51
Test Mode : 2M bandedge Low ch Tested by : Barry Lee

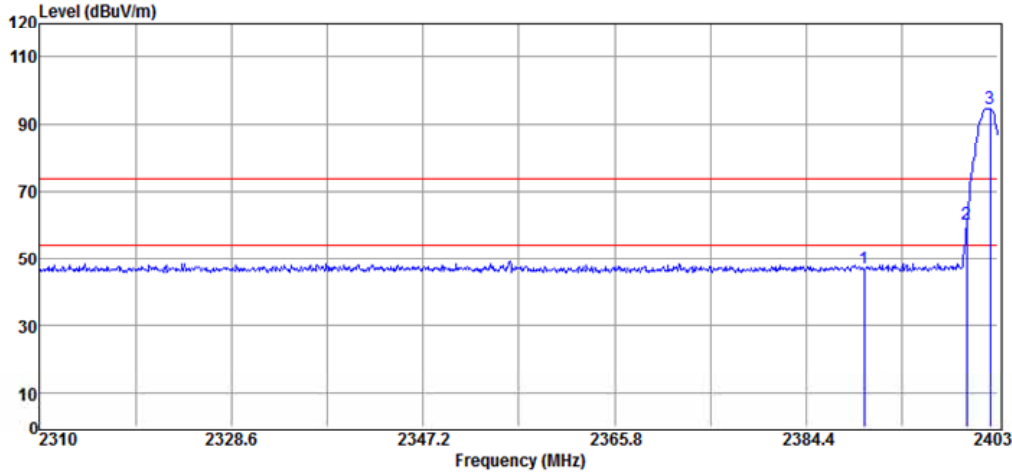

No	Freq MHz	Reading dBuV	Factor dB/m	Level dBuV/m	Limit dBuV/m	Margin dB	Remark	Pol V/H
1	2390.00	44.48	2.33	46.81	74.00	-27.19	Peak	VERTICAL
2	2400.00	57.94	2.41	60.35	74.51	-14.16	Peak	VERTICAL
3	2402.26	92.10	2.41	94.51	F	--	Peak	VERTICAL

Note: "F" denotes fundamental frequency.

International Standard Laboratory Corp.
 Company Address: No.120, Lane 180, Hsin Ho Rd.
 Lung-Tan Dist., Tao Yuan City 325, Taiwan
 Date: 2023-03-15

Project Number. : 23LR0029 Temp.()/RH(%) : 23/51
 Test Mode : 2M bandedge Low ch Tested by : Barry Lee

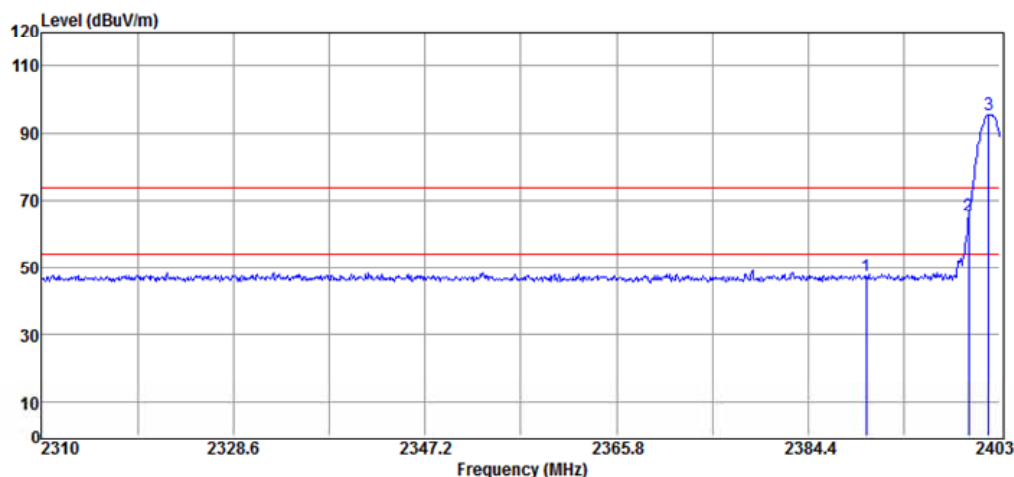

No	Freq MHz	Reading dBuV	Factor dB/m	Level dBuV/m	Limit dBuV/m	Margin dB	Remark	Pol V/H
1	2390.00	44.91	2.33	47.24	74.00	-26.76	Peak	HORIZONTAL
2	2400.00	63.20	2.41	65.61	75.39	-9.78	Peak	HORIZONTAL
3	2401.88	92.98	2.41	95.39	F	--	Peak	HORIZONTAL

Note: "F" denotes fundamental frequency.

International Standard Laboratory Corp.
 Company Address: No.120, Lane 180, Hsin Ho Rd.
 Lung-Tan Dist., Tao Yuan City 325, Taiwan
 Date: 2023-03-15

Project Number. : 23LR0029 Temp.()/RH(%) : 23/51
 Test Mode : 2M bandedge High ch Tested by : Barry Lee

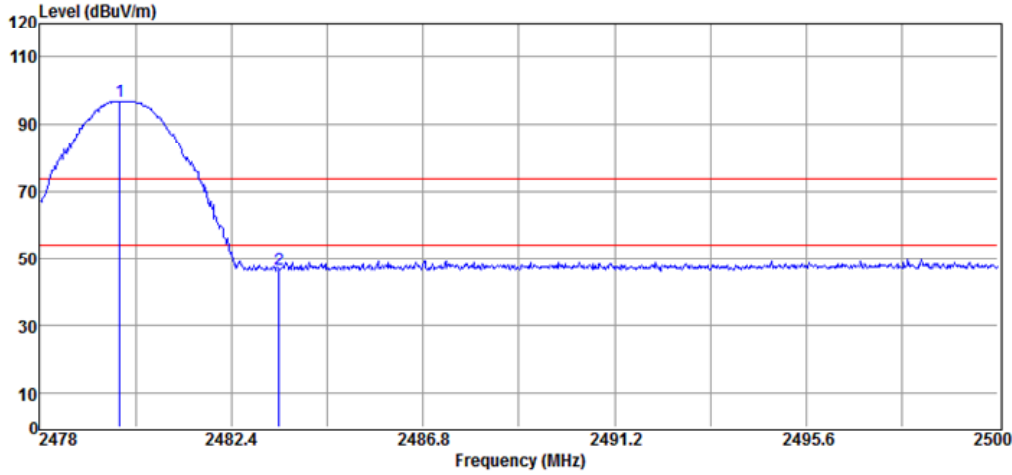

No	Freq MHz	Reading dBuV	Factor dB/m	Level dBuV/m	Limit dBuV/m	Margin dB	Remark	Pol V/H
1	2479.85	93.91	2.74	96.65	F	--	Peak	VERTICAL
2	2483.50	43.85	2.76	46.61	74.00	-27.39	Peak	VERTICAL

Note: "F" denotes fundamental frequency.

International Standard Laboratory Corp.
 Company Address: No.120, Lane 180, Hsin Ho Rd.
 Lung-Tan Dist., Tao Yuan City 325, Taiwan
 Date: 2023-03-15

Project Number. : 23LR0029 Temp.()/RH(%) : 23/51
 Test Mode : 2M bandedge High ch Tested by : Barry Lee

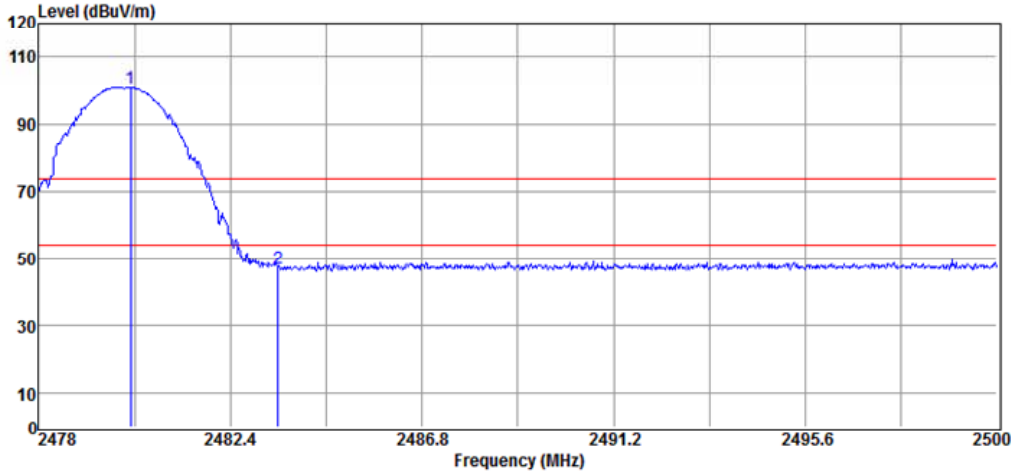

No	Freq MHz	Reading dBuV	Factor dB/m	Level dBuV/m	Limit dBuV/m	Margin dB	Remark	Pol V/H
1	2480.11	97.84	2.74	100.58	F	--	Peak	HORIZONTAL
2	2483.50	44.43	2.76	47.19	74.00	-26.81	Peak	HORIZONTAL

Note: "F" denotes fundamental frequency.

International Standard Laboratory Corp.
Company Address: No.120, Lane 180, Hsin Ho Rd.
Lung-Tan Dist., Tao Yuan City 325, Taiwan
Date: 2023-03-15

Project Number. : 23LR0029 Temp.()/RH(%) : 23/51
Test Mode : 3M bandedge Low ch Tested by : Barry Lee

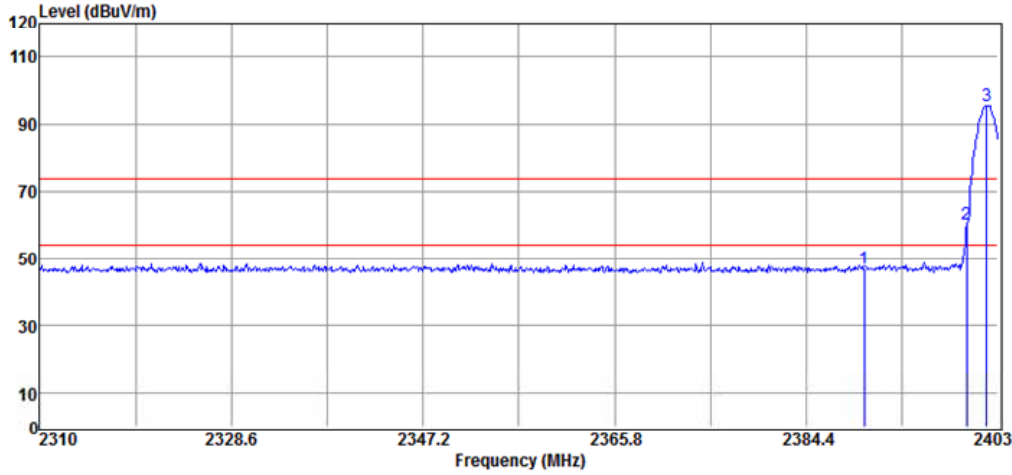

No	Freq MHz	Reading dBuV	Factor dB/m	Level dBuV/m	Limit dBuV/m	Margin dB	Remark	Pol V/H
1	2390.00	44.51	2.33	46.84	74.00	-27.16	Peak	VERTICAL
2	2400.00	57.76	2.41	60.17	75.40	-15.23	Peak	VERTICAL
3	2401.88	92.99	2.41	95.40	F	--	Peak	VERTICAL

Note: "F" denotes fundamental frequency.

International Standard Laboratory Corp.
 Company Address: No.120, Lane 180, Hsin Ho Rd.
 Lung-Tan Dist., Tao Yuan City 325, Taiwan
 Date: 2023-03-15

Project Number. : 23LR0029 Temp.()/RH(%) : 23/51
 Test Mode : 3M bandedge Low ch Tested by : Barry Lee

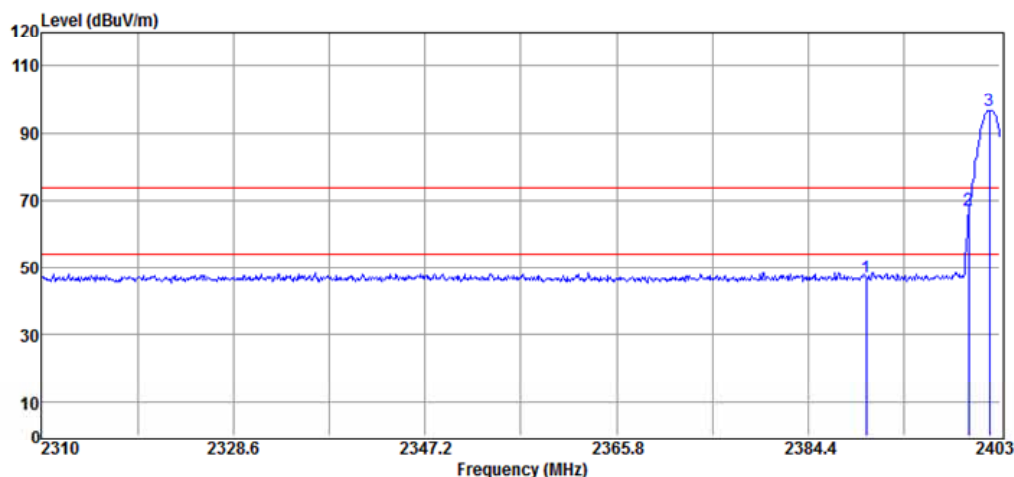

No	Freq MHz	Reading dBuV	Factor dB/m	Level dBuV/m	Limit dBuV/m	Margin dB	Remark	Pol V/H
1	2390.00	44.50	2.33	46.83	74.00	-27.17	Peak	HORIZONTAL
2	2400.00	64.77	2.41	67.18	76.43	-9.25	Peak	HORIZONTAL
3	2401.98	94.02	2.41	96.43	F	--	Peak	HORIZONTAL

Note: "F" denotes fundamental frequency.

International Standard Laboratory Corp.
 Company Address: No.120, Lane 180, Hsin Ho Rd.
 Lung-Tan Dist., Tao Yuan City 325, Taiwan
 Date: 2023-03-15

Project Number. : 23LR0029 Temp.()/RH(%) : 23/51
 Test Mode : 3M bandedge High ch Tested by : Barry Lee

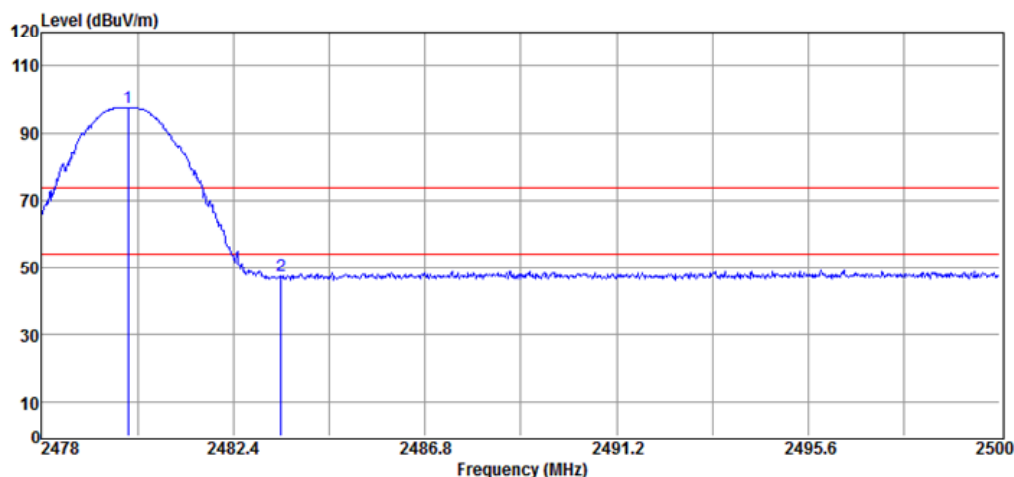

No	Freq MHz	Reading dBuV	Factor dB/m	Level dBuV/m	Limit dBuV/m	Margin dB	Remark	Pol V/H
1	2479.98	94.74	2.74	97.48	F	--	Peak	VERTICAL
2	2483.50	44.64	2.76	47.40	74.00	-26.60	Peak	VERTICAL

Note: "F" denotes fundamental frequency.

International Standard Laboratory Corp.
 Company Address: No.120, Lane 180, Hsin Ho Rd.
 Lung-Tan Dist., Tao Yuan City 325, Taiwan
 Date: 2023-03-15

Project Number. : 23LR0029 Temp.()/RH(%) : 23/51
 Test Mode : 3M bandedge High ch Tested by : Barry Lee

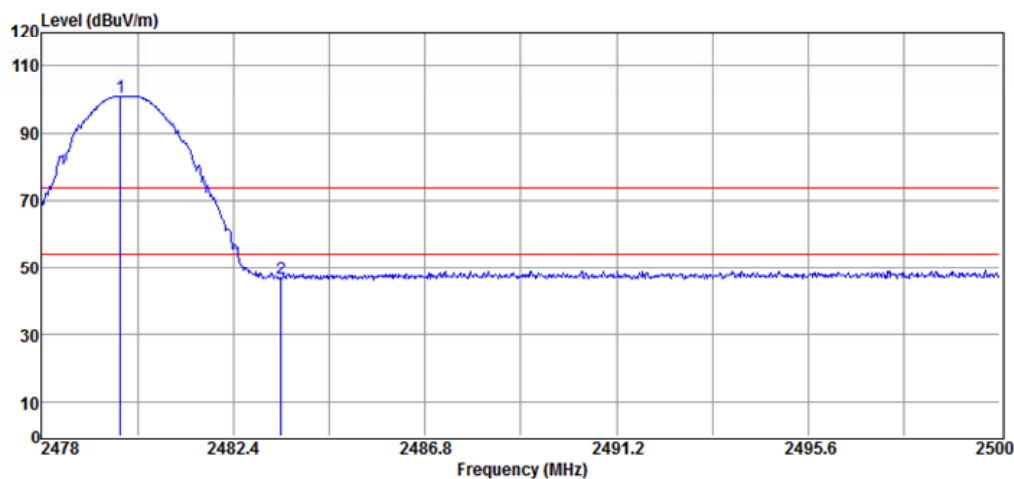

No	Freq MHz	Reading dBuV	Factor dB/m	Level dBuV/m	Limit dBuV/m	Margin dB	Remark	Pol V/H
1	2479.80	97.99	2.74	100.73	F	--	Peak	HORIZONTAL
2	2483.50	43.89	2.76	46.65	74.00	-27.35	Peak	HORIZONTAL

Note: "F" denotes fundamental frequency.

International Standard Laboratory Corp.
 Company Address: No.120, Lane 180, Hsin Ho Rd.
 Lung-Tan Dist., Tao Yuan City 325, Taiwan
 Date: 2023-03-15

Project Number. : 23LR0029 Temp.()/RH(%) : 23/51
 Test Mode : 1M bandedge Low ch (Hopping) Tested by : Barry Lee

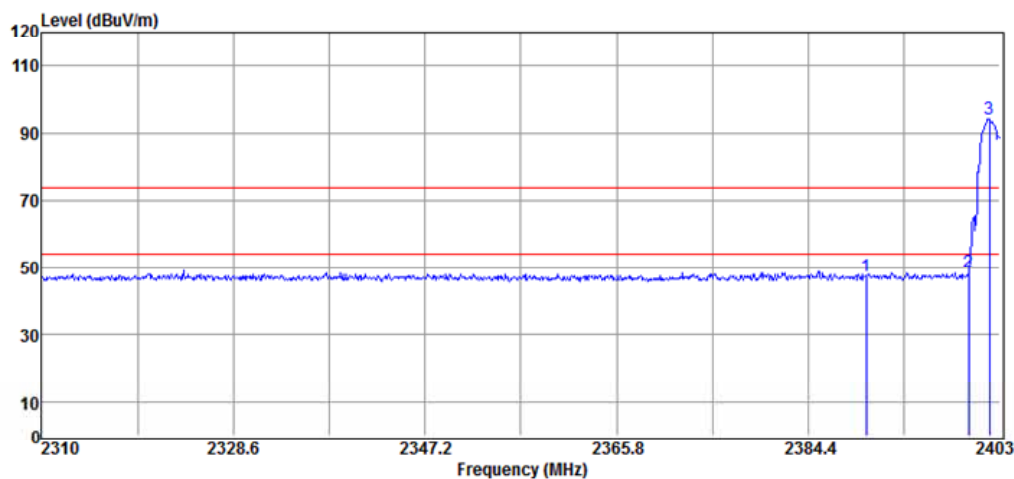

No	Freq MHz	Reading dBuV	Factor dB/m	Level dBuV/m	Limit dBuV/m	Margin dB	Remark	Pol V/H
1	2390.00	45.13	2.33	47.46	74.00	-26.54	Peak	VERTICAL
2	2400.00	46.32	2.41	48.73	74.15	-25.42	Peak	VERTICAL
3	2401.98	91.74	2.41	94.15	F	--	Peak	VERTICAL

Note: "F" denotes fundamental frequency.

International Standard Laboratory Corp.
 Company Address: No.120, Lane 180, Hsin Ho Rd.
 Lung-Tan Dist., Tao Yuan City 325, Taiwan
 Date: 2023-03-15

Project Number. : 23LR0029 Temp.()/RH(%) : 23/51
 Test Mode : 1M bandedge Low ch (Hopping) Tested by : Barry Lee

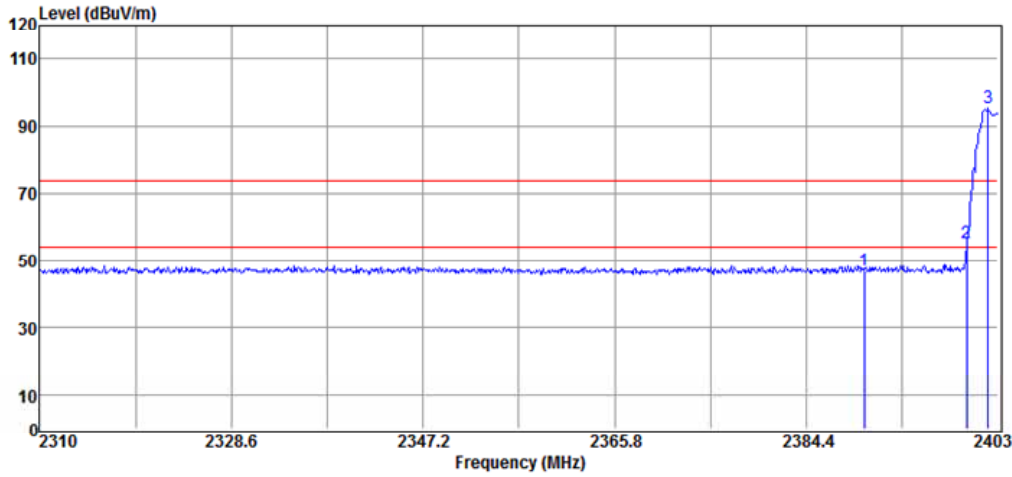

No	Freq MHz	Reading dBuV	Factor dB/m	Level dBuV/m	Limit dBuV/m	Margin dB	Remark	Pol V/H
1	2390.00	44.58	2.33	46.91	74.00	-27.09	Peak	HORIZONTAL
2	2400.00	52.93	2.41	55.34	75.07	-19.73	Peak	HORIZONTAL
3	2402.07	92.66	2.41	95.07	F	--	Peak	HORIZONTAL

Note: "F" denotes fundamental frequency.

International Standard Laboratory Corp.
 Company Address: No.120, Lane 180, Hsin Ho Rd.
 Lung-Tan Dist., Tao Yuan City 325, Taiwan
 Date: 2023-03-15

Project Number. : 23LR0029 Temp.()/RH(%) : 23/51
 Test Mode : 1M bandedge High ch (Hopping) Tested by : Barry Lee

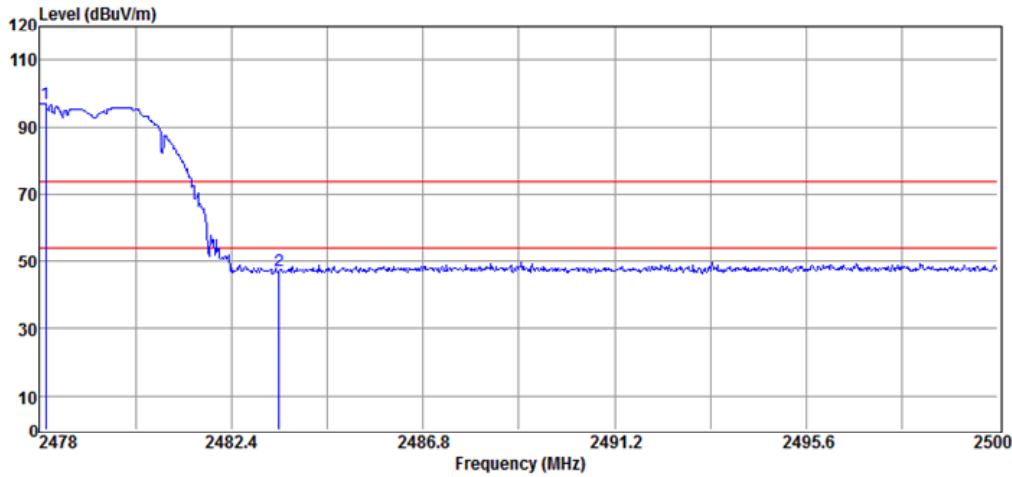

No	Freq MHz	Reading dBuV	Factor dB/m	Level dBuV/m	Limit dBuV/m	Margin dB	Remark	Pol V/H
1	2478.13	94.16	2.73	96.89	F	--	Peak	VERTICAL
2	2483.50	44.31	2.76	47.07	74.00	-26.93	Peak	VERTICAL

Note: "F" denotes fundamental frequency.

International Standard Laboratory Corp.
Company Address: No.120, Lane 180, Hsin Ho Rd.
Lung-Tan Dist., Tao Yuan City 325, Taiwan

Date: 2023-03-15

Project Number. : 23LR0029 Temp.()/RH(%) : 23/51

Test Mode : 1M bandedge High ch (Hopping) Tested by :

Barry Lee

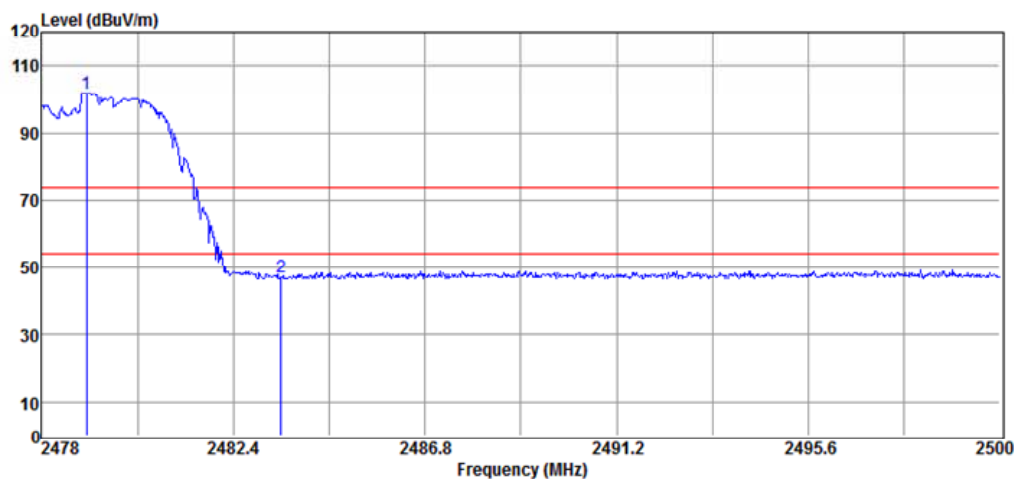

No	Freq MHz	Reading dBuV	Factor dB/m	Level dBuV/m	Limit dBuV/m	Margin dB	Remark	Pol V/H
1	2479.03	99.06	2.74	101.80	F	--	Peak	HORIZONTAL
2	2483.50	44.15	2.76	46.91	74.00	-27.09	Peak	HORIZONTAL

Note: "F" denotes fundamental frequency.

International Standard Laboratory Corp.
Company Address: No.120, Lane 180, Hsin Ho Rd.
Lung-Tan Dist., Tao Yuan City 325, Taiwan
Date: 2023-03-15

Project Number. : 23LR0029 Temp.()/RH(%) : 23/51
Test Mode : 2M bandedge Low ch (Hopping) Tested by : Barry Lee

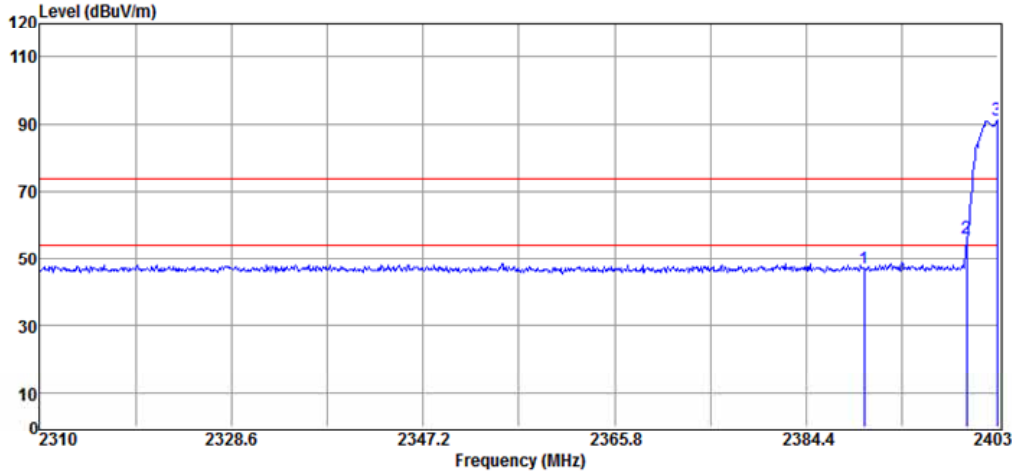

No	Freq MHz	Reading dBuV	Factor dB/m	Level dBuV/m	Limit dBuV/m	Margin dB	Remark	Pol V/H
1	2390.00	44.69	2.33	47.02	74.00	-26.98	Peak	VERTICAL
2	2400.00	53.82	2.41	56.23	70.95	-14.72	Peak	VERTICAL
3	2402.91	88.53	2.42	90.95	F	--	Peak	VERTICAL

Note: "F" denotes fundamental frequency.

International Standard Laboratory Corp.
 Company Address: No.120, Lane 180, Hsin Ho Rd.
 Lung-Tan Dist., Tao Yuan City 325, Taiwan
 Date: 2023-03-15

Project Number. : 23LR0029 Temp.()/RH(%) : 23/51
 Test Mode : 2M bandedge Low ch (Hopping) Tested by : Barry Lee

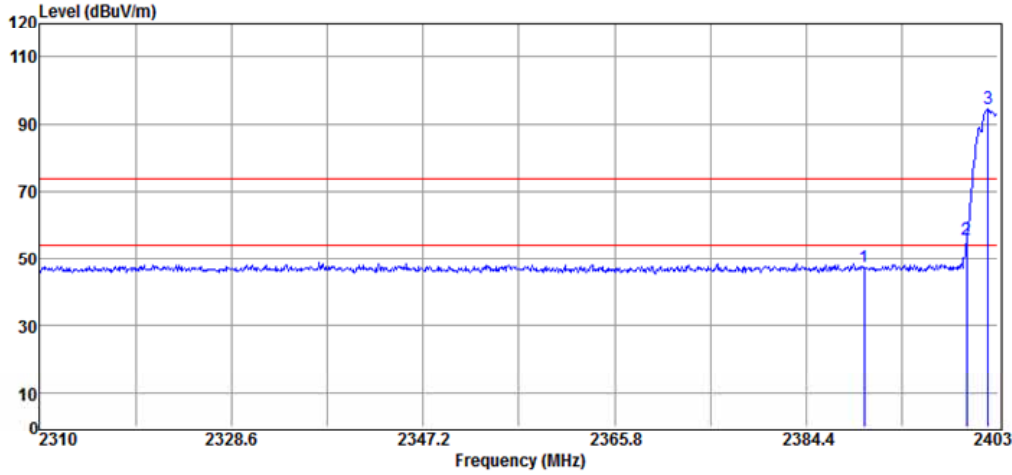

No	Freq MHz	Reading dBuV	Factor dB/m	Level dBuV/m	Limit dBuV/m	Margin dB	Remark	Pol V/H
1	2390.00	44.89	2.33	47.22	74.00	-26.78	Peak	HORIZONTAL
2	2400.00	53.22	2.41	55.63	74.29	-18.66	Peak	HORIZONTAL
3	2402.07	91.88	2.41	94.29	F	--	Peak	HORIZONTAL

Note: "F" denotes fundamental frequency.

International Standard Laboratory Corp.
 Company Address: No.120, Lane 180, Hsin Ho Rd.
 Lung-Tan Dist., Tao Yuan City 325, Taiwan
 Date: 2023-03-15

Project Number. : 23LR0029 Temp.()/RH(%) : 23/51
 Test Mode : 2M bandedge High ch (Hopping) Tested by : Barry Lee

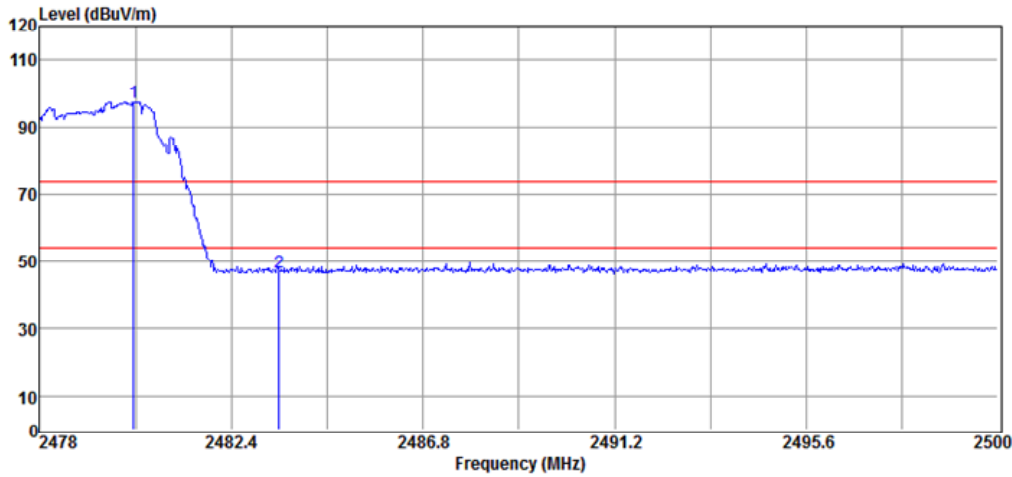

No	Freq MHz	Reading dBuV	Factor dB/m	Level dBuV/m	Limit dBuV/m	Margin dB	Remark	Pol V/H
1	2480.16	94.76	2.74	97.50	F	--	Peak	VERTICAL
2	2483.50	43.74	2.76	46.50	74.00	-27.50	Peak	VERTICAL

Note: "F" denotes fundamental frequency.

International Standard Laboratory Corp.
 Company Address: No.120, Lane 180, Hsin Ho Rd.
 Lung-Tan Dist., Tao Yuan City 325, Taiwan
 Date: 2023-03-15

Project Number. : 23LR0029 Temp.()/RH(%) : 23/51
 Test Mode : 2M bandedge High ch (Hopping) Tested by : Barry Lee

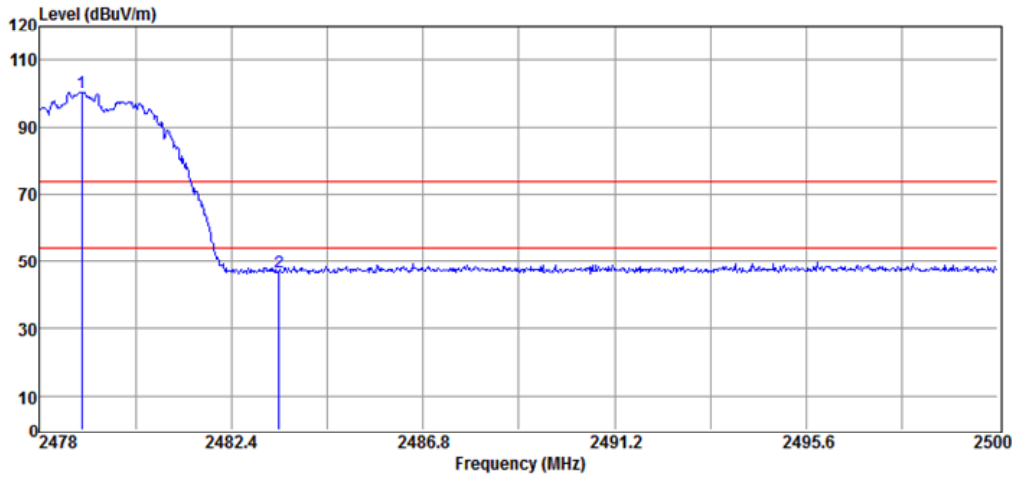

No	Freq MHz	Reading dBuV	Factor dB/m	Level dBuV/m	Limit dBuV/m	Margin dB	Remark	Pol V/H
1	2478.97	97.39	2.74	100.13	F	--	Peak	HORIZONTAL
2	2483.50	43.91	2.76	46.67	74.00	-27.33	Peak	HORIZONTAL

Note: "F" denotes fundamental frequency.

International Standard Laboratory Corp.
 Company Address: No.120, Lane 180, Hsin Ho Rd.
 Lung-Tan Dist., Tao Yuan City 325, Taiwan
 Date: 2023-03-15

Project Number. : 23LR0029 Temp.()/RH(%) : 23/51
 Test Mode : 3M bandedge Low ch (Hopping) Tested by : Barry Lee

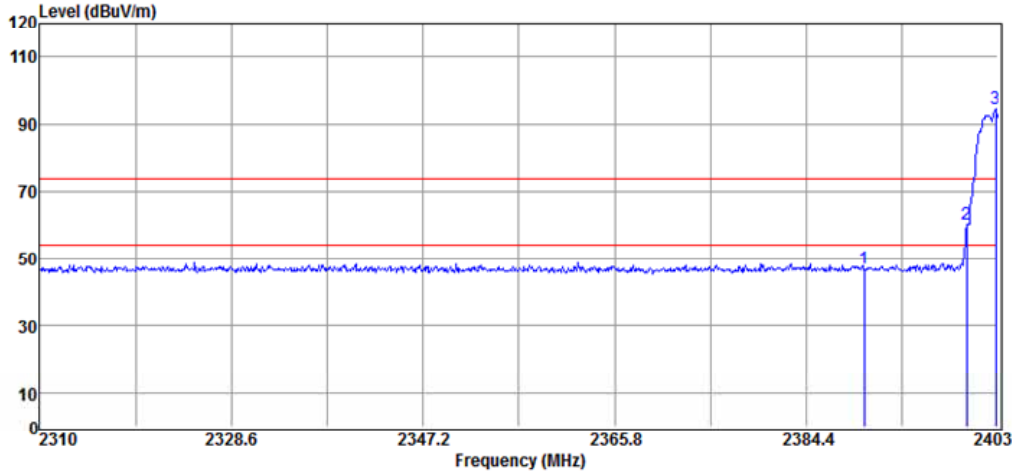

No	Freq MHz	Reading dBuV	Factor dB/m	Level dBuV/m	Limit dBuV/m	Margin dB	Remark	Pol V/H
1	2390.00	44.57	2.33	46.90	74.00	-27.10	Peak	VERTICAL
2	2400.00	57.79	2.41	60.20	74.24	-14.04	Peak	VERTICAL
3	2402.81	91.82	2.42	94.24	F	--	Peak	VERTICAL

Note: "F" denotes fundamental frequency.

International Standard Laboratory Corp.
 Company Address: No.120, Lane 180, Hsin Ho Rd.
 Lung-Tan Dist., Tao Yuan City 325, Taiwan
 Date: 2023-03-15

Project Number. : 23LR0029 Temp.()/RH(%) : 23/51
 Test Mode : 3M bandedge Low ch (Hopping) Tested by : Barry Lee

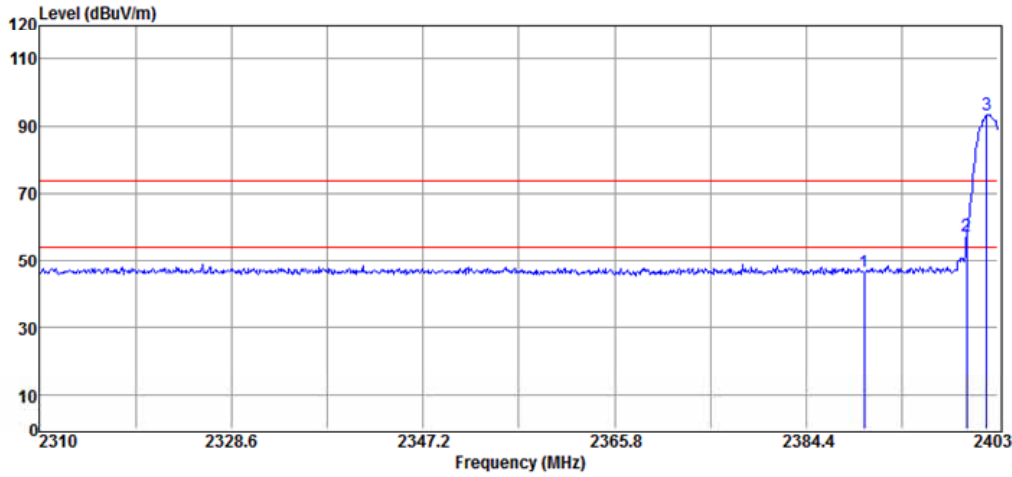

No	Freq MHz	Reading dBuV	Factor dB/m	Level dBuV/m	Limit dBuV/m	Margin dB	Remark	Pol V/H
1	2390.00	44.42	2.33	46.75	74.00	-27.25	Peak	HORIZONTAL
2	2400.00	54.84	2.41	57.25	73.13	-15.88	Peak	HORIZONTAL
3	2401.88	90.72	2.41	93.13	F	--	Peak	HORIZONTAL

Note: "F" denotes fundamental frequency.

International Standard Laboratory Corp.
 Company Address: No.120, Lane 180, Hsin Ho Rd.
 Lung-Tan Dist., Tao Yuan City 325, Taiwan

Date: 2023-03-15

Project Number. : 23LR0029 Temp.()/RH(%) : 23/51
 Test Mode : 3M bandedge High ch (Hopping) Tested by : Barry Lee

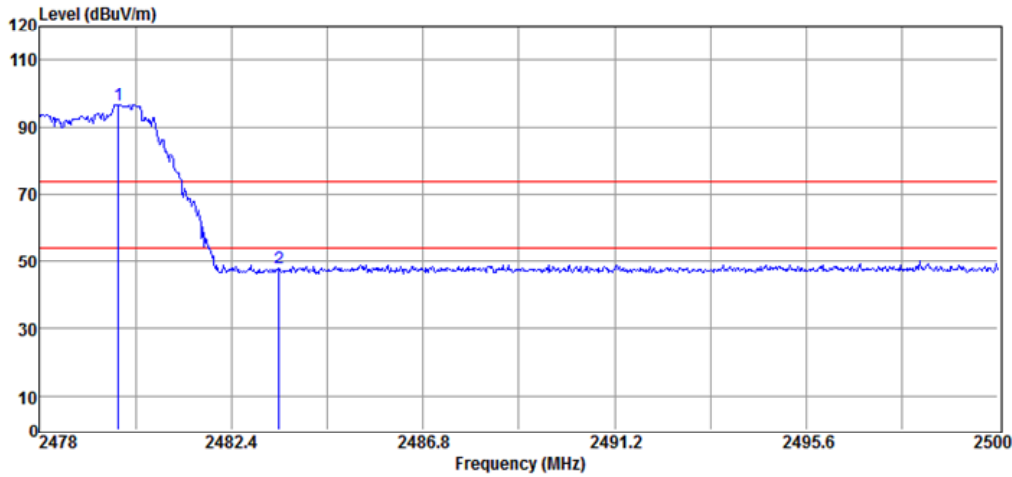

No	Freq MHz	Reading dBuV	Factor dB/m	Level dBuV/m	Limit dBuV/m	Margin dB	Remark	Pol V/H
1	2479.80	93.71	2.74	96.45	F	--	Peak	VERTICAL
2	2483.50	44.99	2.76	47.75	74.00	-26.25	Peak	VERTICAL

Note: "F" denotes fundamental frequency.

International Standard Laboratory Corp.
Company Address: No.120, Lane 180, Hsin Ho Rd.
Lung-Tan Dist., Tao Yuan City 325, Taiwan

Date: 2023-03-15

Project Number. : 23LR0029 Temp.()/RH(%) : 23/51
Test Mode : 3M bandedge High ch (Hopping) Tested by : Barry Lee

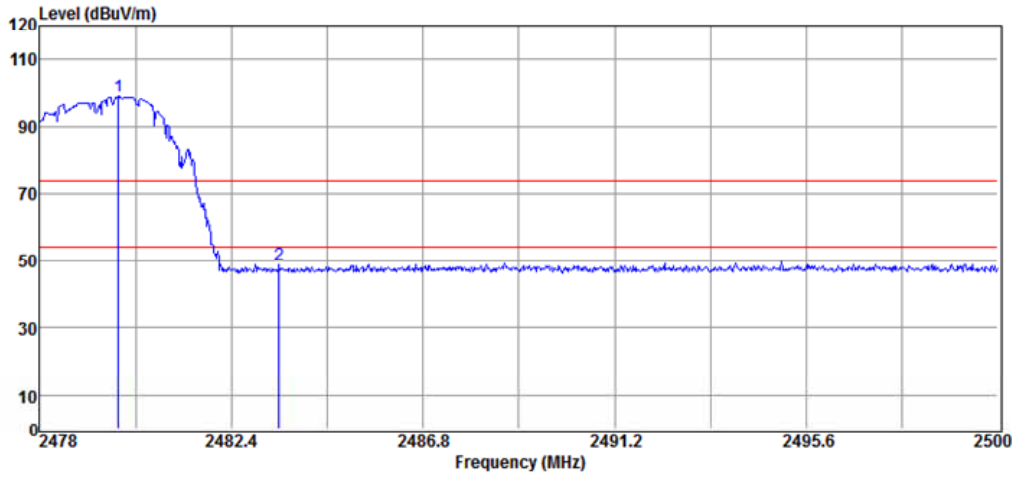

No	Freq MHz	Reading dBuV	Factor dB/m	Level dBuV/m	Limit dBuV/m	Margin dB	Remark	Pol V/H
1	2479.80	96.07	2.74	98.81	F	--	Peak	HORIZONTAL
2	2483.50	45.93	2.76	48.69	74.00	-25.31	Peak	HORIZONTAL

Note: "F" denotes fundamental frequency.

9. 20dB Bandwidth

9.1 Standard Applicable

According to §15.247(a)(1) for frequency hopping systems operating in the 2400MHz-2483.5 MHz no limit for 20dB bandwidth.

9.2 Measurement Procedure

1. Place the EUT on the table and set it in transmitting mode.
2. Remove the antenna from the EUT and then connect a low loss RF cable from the antenna port to the spectrum analyzer.
3. Set the spectrum analyzer as RBW= 1 % - 5% of Bandwidth., Span= 3MHz, Sweep=auto
4. Mark the peak frequency and -20dB (upper and lower) frequency and 99%.
5. Repeat above procedures until all frequency measured were complete.

9.3 Measurement Result

BDR Mode

CH	20dB Bandwidth (MHz)
Low	0.925
Mid	0.924
High	0.926

EDR 2M Mode

CH	20dB Bandwidth (MHz)	2/3* 20dB Bandwidth (MHz)
Lower	1.255	0.837
Mid	1.237	0.825
Higher	1.267	0.844

EDR 3M Mode

CH	20dB Bandwidth (MHz)	2/3* 20dB Bandwidth (MHz)
Lower	1.255	0.837
Mid	1.267	0.845
Higher	1.259	0.839

Test Data: BDR\2402MHz



Test Data: BDR\2441MHz



Test Data: BDR\2480MHz



Test Data: EDR 2M\2402MHz

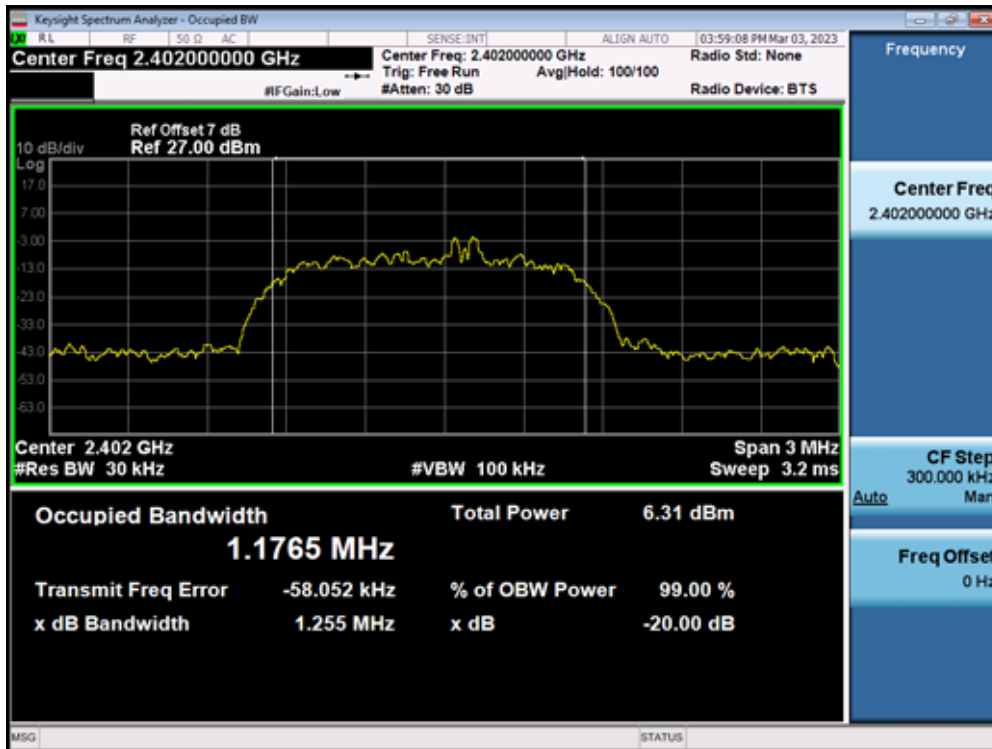

Test Data: EDR 2M\2441MHz

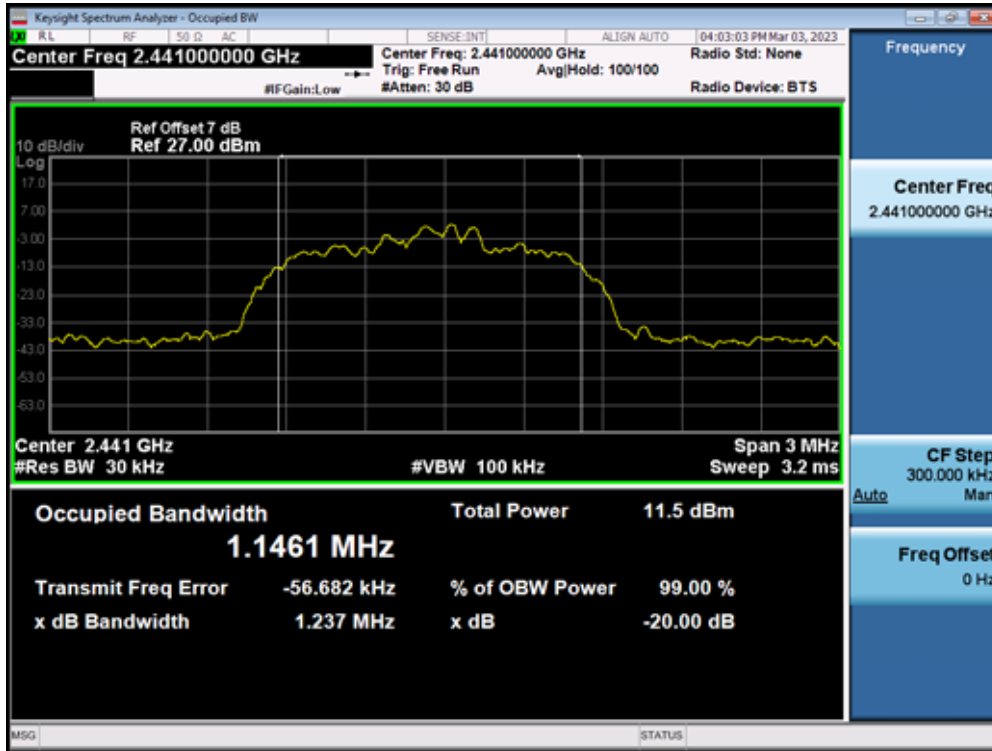

Test Data: EDR 2M\2480MHz



Test Data: EDR 3M\2402MHz

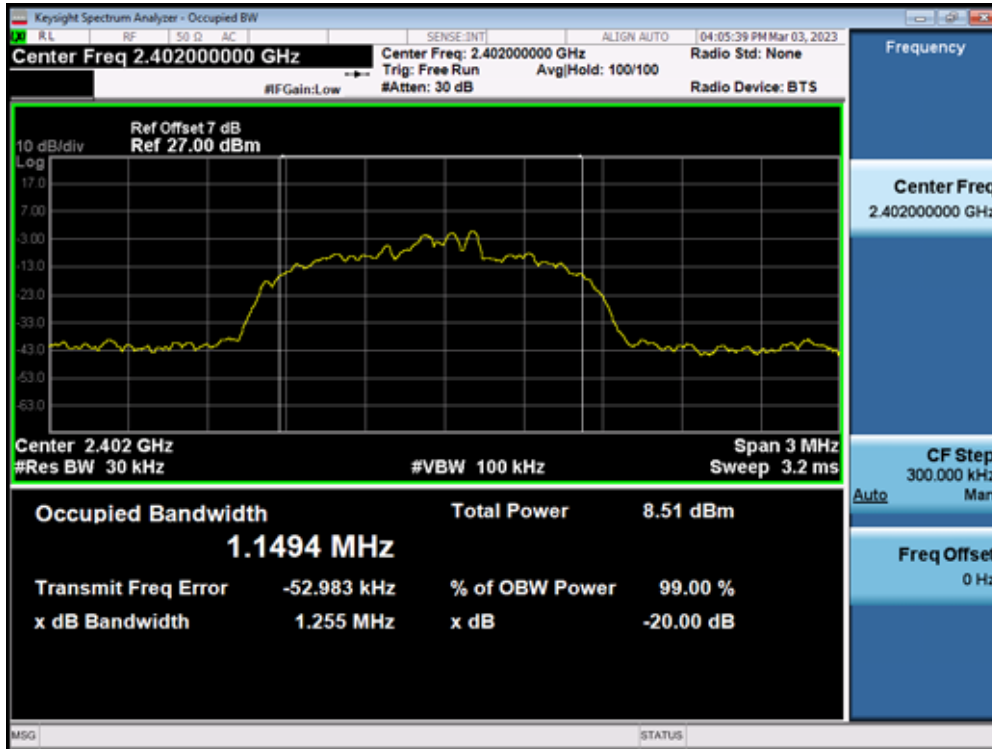

Test Data: EDR 3M\2441MHz

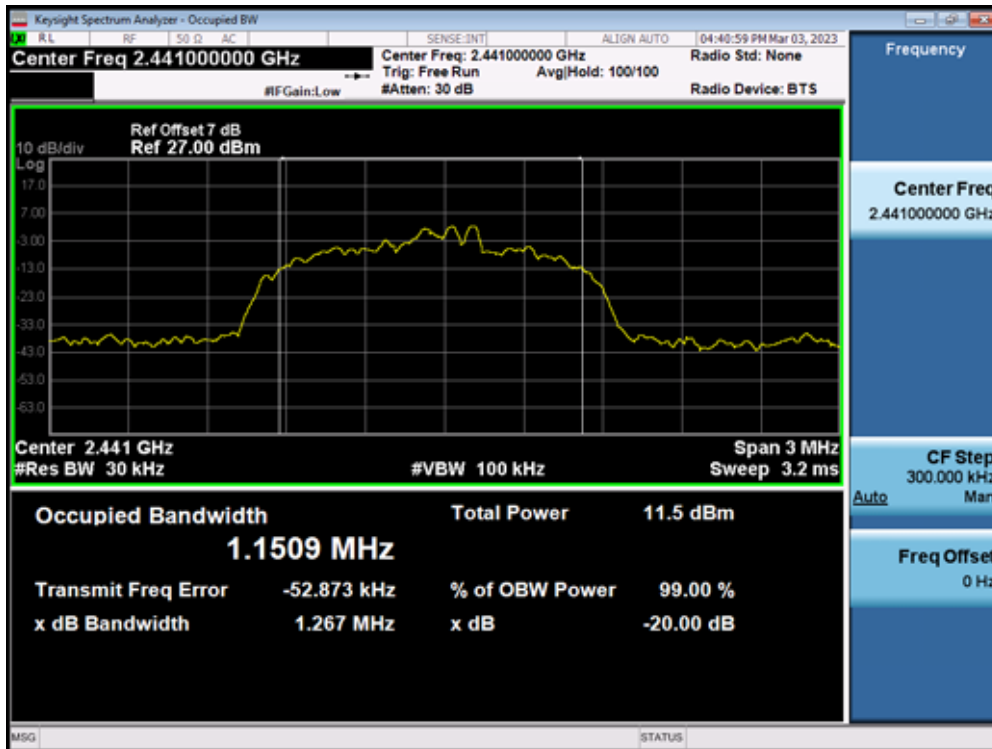

Test Data: EDR 3M\2480MHz

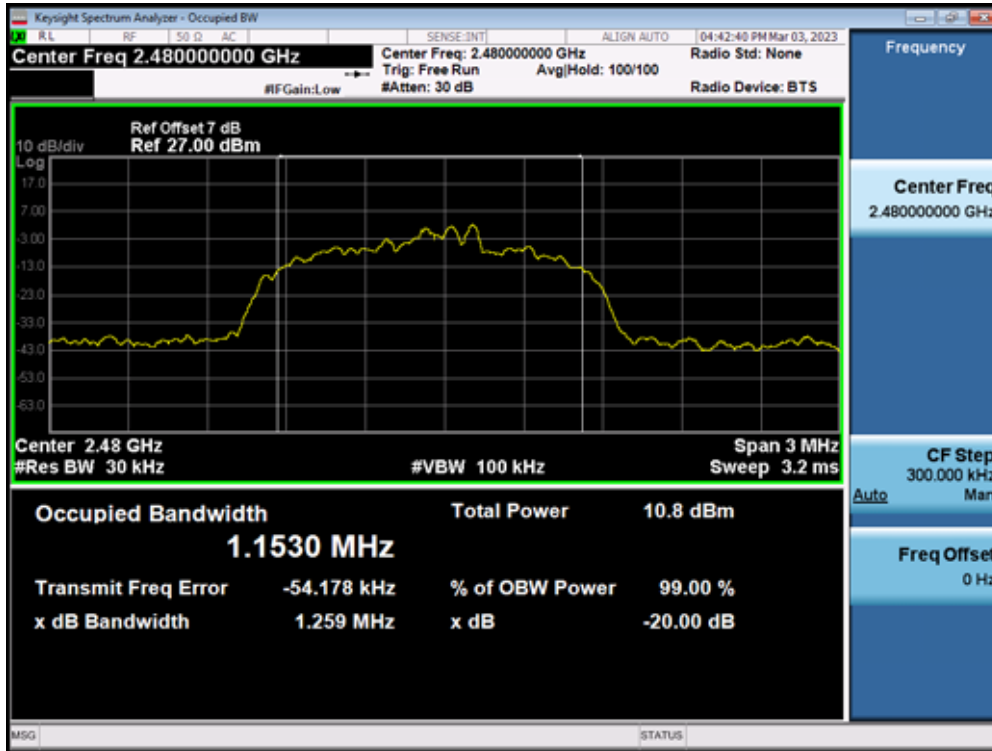

10. Frequency Separation

10.1 Standard Applicable

According to FCC 15.247 (a)(1)

Frequency hopping systems shall have hopping channel carrier frequencies separated by a minimum of 25 kHz or the 20 dB bandwidth of the hopping channel, whichever is greater. Alternatively, frequency hopping systems operating in the 2400-2483.5 MHz band may have hopping channel carrier frequencies that are separated by 25 kHz or two-thirds of the 20 dB bandwidth of the hopping channel, whichever is greater, provided the systems operate with an output power no greater than 125 mW.

10.2 Measurement Procedure

The EUT shall have its hopping function enabled. Use the following spectrum analyzer settings:

1. Span: Wide enough to capture the peaks of two adjacent channels.
2. RBW: Start with the RBW set to approximately 30% of the channel spacing; adjust as necessary to best identify the center of each individual channel.
3. $VBW \geq RBW$, Sweep: Auto.
4. Detector function: Peak.
5. Trace: Max hold.
6. Allow the trace to stabilize.
7. Use the marker-delta function to determine the separation between the peaks of the adjacent channels.

10.3 Measurement Result

Channel separation (MHz)	Limit	Result
1	$\geq 25\text{kHz}$ or $2/3$ of the 20dB bandwidth (whichever is greater)	PASS

Test Data: 2402MHz



Test Data: 2441MHz



Test Data: 2480MHz



11. Number of Hopping Frequency

11.1 Standard Applicable

According to §15.247(a)(1)(iii), Frequency hopping systems operating in the 2400MHz-2483.5 MHz bands shall use at least 15 hopping frequencies.

11.2 Measurement Procedure

1. Set the EUT in hopping mode.
2. Remove the antenna from the EUT and then connect a low loss RF cable from the antenna port to the spectrum analyzer.
3. Set spectrum analyzer Start=2400MHz, Stop = 2441.5MHz and Start=2441.5MHz, Stop = 2483.5MHz, Sweep = auto.
4. Set the spectrum analyzer as RBW=100kHz, VBW=300kHz
5. Max hold, view and count how many channels in the band.

11.3 Measurement Result

Test Data: 1

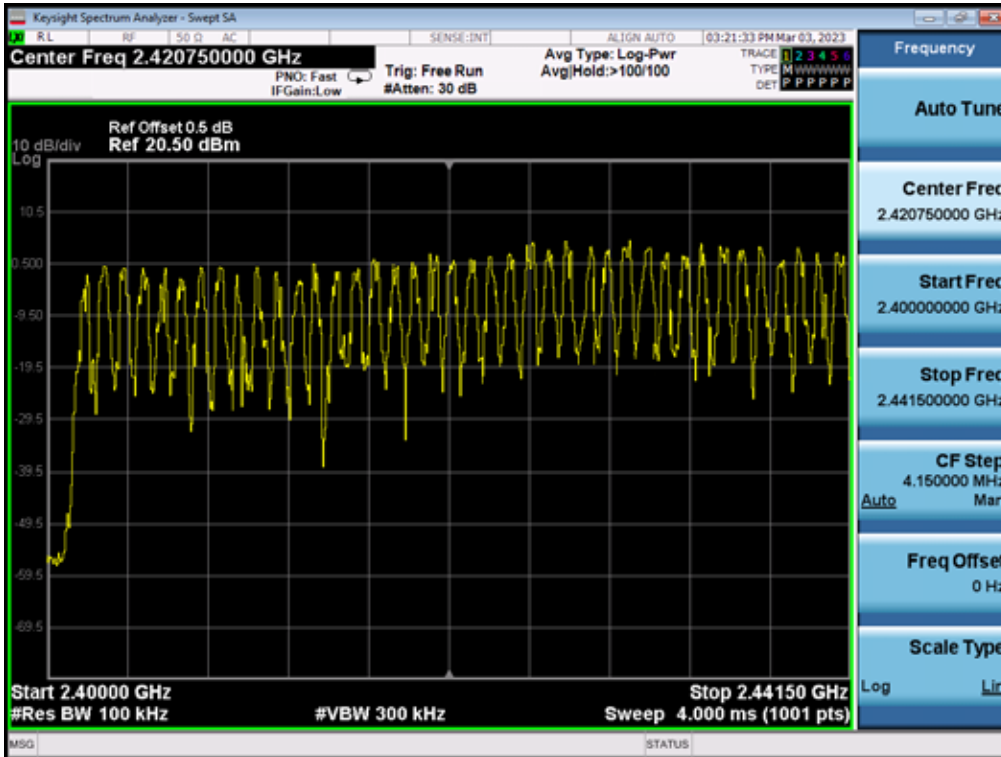

Test Data: 2

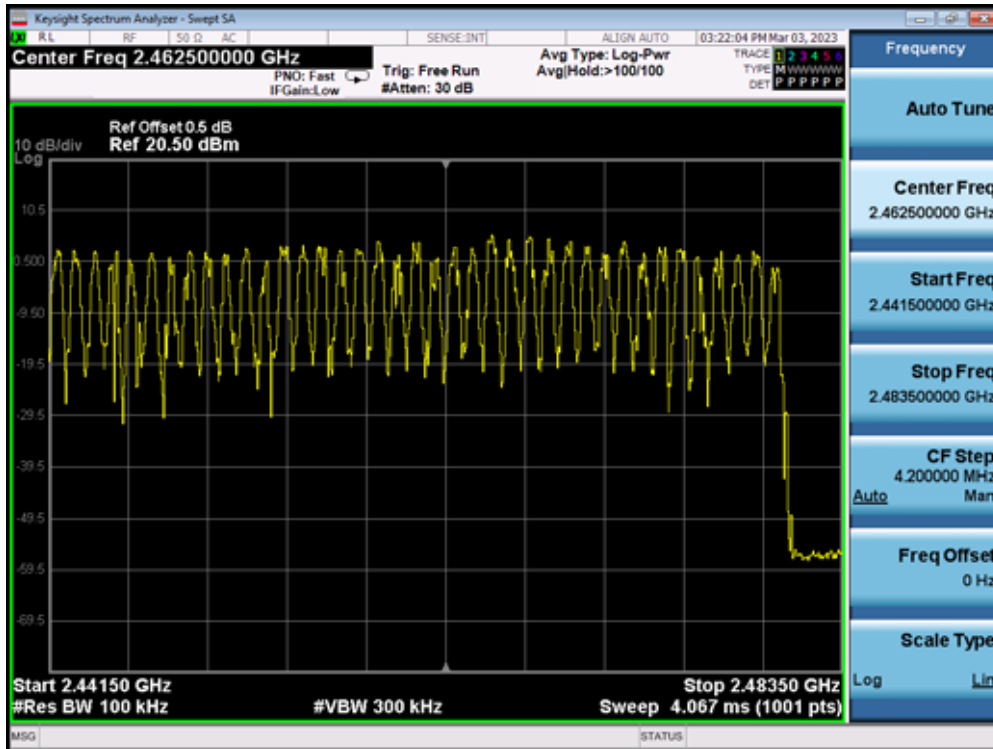

12. Time of Occupancy (Dwell Time)

12.1 Standard Applicable

According to §15.247(a)(1)(iii), Frequency hopping systems operating in the 2400MHz-2483.5 MHz band. The average time of occupancy on any frequency shall not greater than 0.4 s within period of 0.4 seconds multiplied by the number of hopping channels are employed.

12.2 Measurement Procedure

1. Set the EUT in hopping mode.
2. Remove the antenna from the EUT and then connect a low loss RF cable from the antenna port to the spectrum analyzer.
3. Set center frequency of spectrum analyzer = operating frequency.
4. Set the spectrum analyzer as RBW / VBW =1MHz, Span = 0Hz, Adjust Sweep time to capture the entire dwell time per hopping channel.
5. Use the marker-delta function to determine the transmit time per hop.

12.3 Measurement Result

A period time = 0.4 (ms) * 79 = 31.6 (s)

CH Low DH1 time slot=0.372 (ms)*(1600/2/79)* 31.6 = 119.04 (ms)
 DH3 time slot=1.630 (ms)*(1600/4/79)* 31.6 = 260.80 (ms)
 DH5 time slot=2.820 (ms)*(1600/6/79)* 31.6 = 300.80 (ms)

CH Mid DH1 time slot=0.372 (ms)*(1600/2/79)* 31.6 = 119.04 (ms)
 DH3 time slot=1.620 (ms)*(1600/4/79)* 31.6 = 259.20 (ms)
 DH5 time slot=2.880 (ms)*(1600/6/79)* 31.6 = 307.20 (ms)

CH High DH1 time slot=0.368 (ms)*(1600/2/79)* 31.6 = 117.76 (ms)
 DH3 time slot=1.610 (ms)*(1600/4/79)* 31.6 = 257.60 (ms)
 DH5 time slot=2.860 (ms)*(1600/6/79)* 31.6 = 305.07 (ms)

AFH mode

A period time = 0.4 (ms) * 20 = 8 (s)

CH Low DH1 time slot=0.372 (ms)*(800/2/20)* 8 = 59.52 (ms)
 DH3 time slot=1.630 (ms)*(800/4/20)* 8 = 130.40 (ms)
 DH5 time slot=2.820 (ms)*(800/6/20)* 8 = 150.40 (ms)

CH Mid DH1 time slot=0.372 (ms)*(800/2/20)* 8 = 59.52 (ms)
 DH3 time slot=1.620 (ms)*(800/4/20)* 8 = 129.60 (ms)
 DH5 time slot=2.880 (ms)*(800/6/20)* 8 = 153.60 (ms)

CH High DH1 time slot=0.368 (ms)*(800/2/20)* 8 = 58.88 (ms)
 DH3 time slot=1.610 (ms)*(800/4/20)* 8 = 128.80 (ms)
 DH5 time slot=2.860 (ms)*(800/6/20)* 8 = 152.53 (ms)

Test Data: DH1\2402MHz

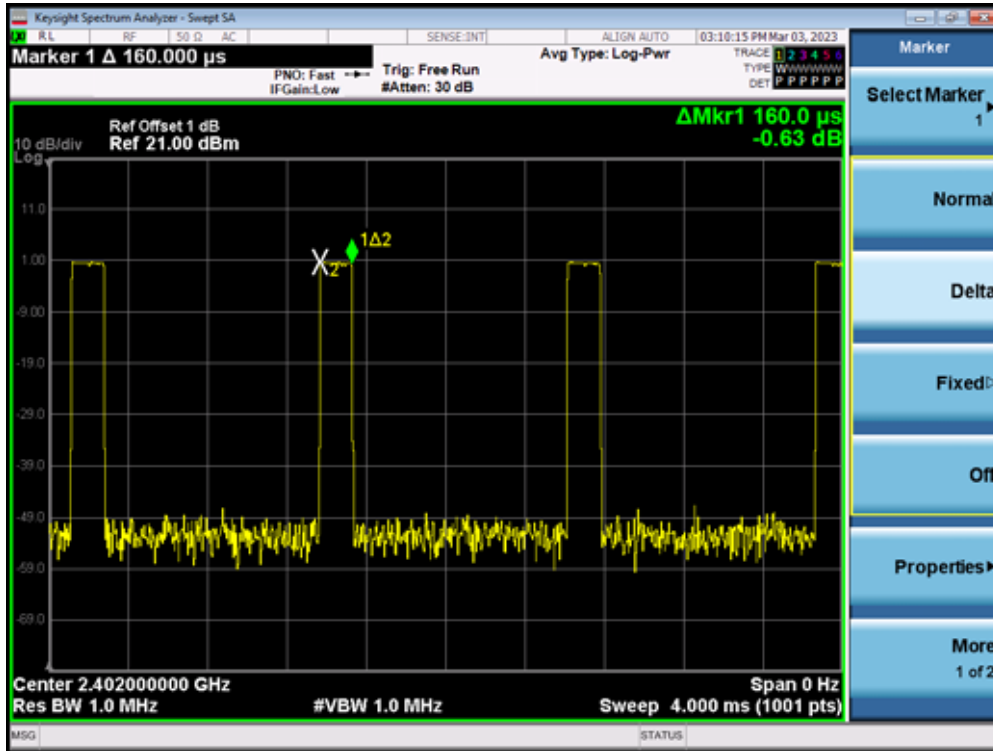

Test Data: DH1\2441MHz

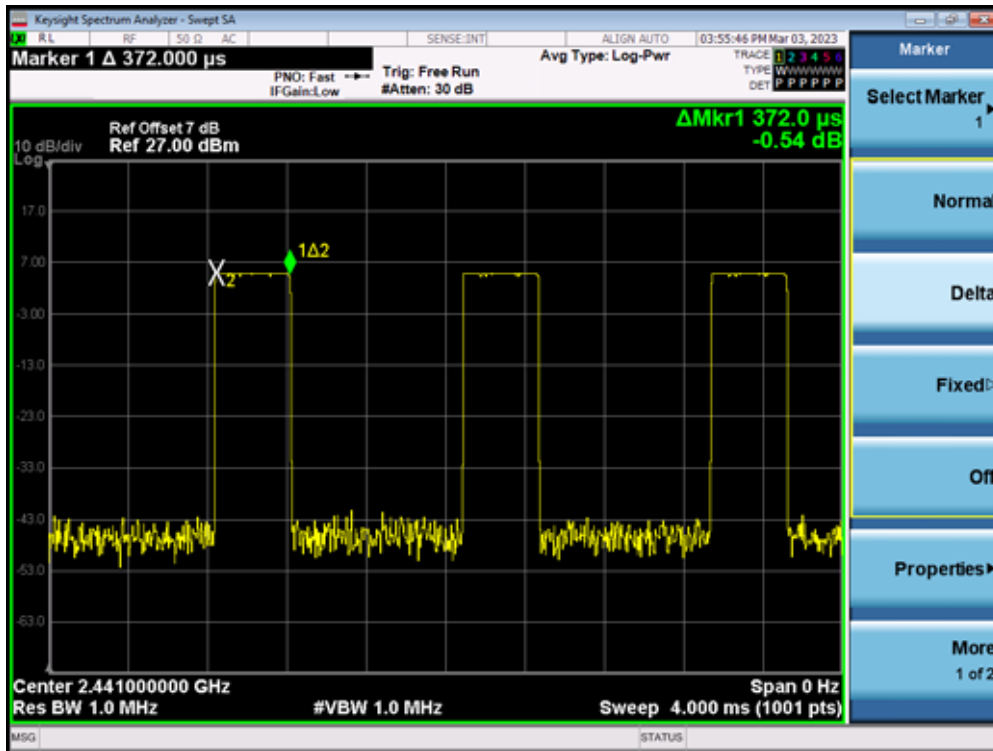

Test Data: DH1\2480MHz

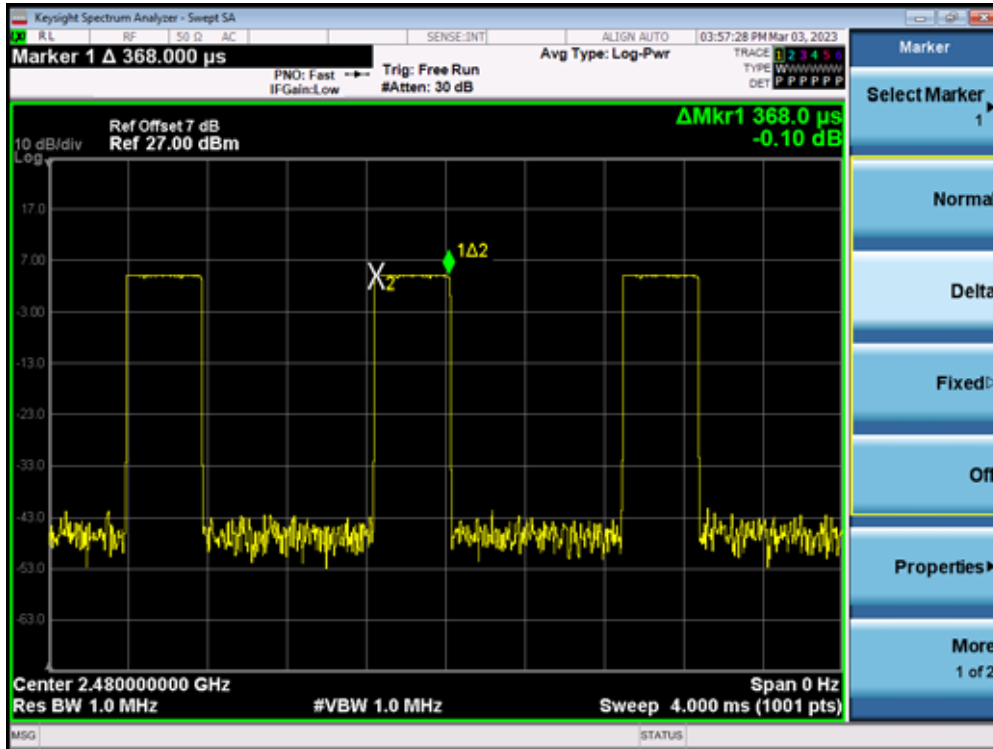

Test Data: DH3\2402MHz

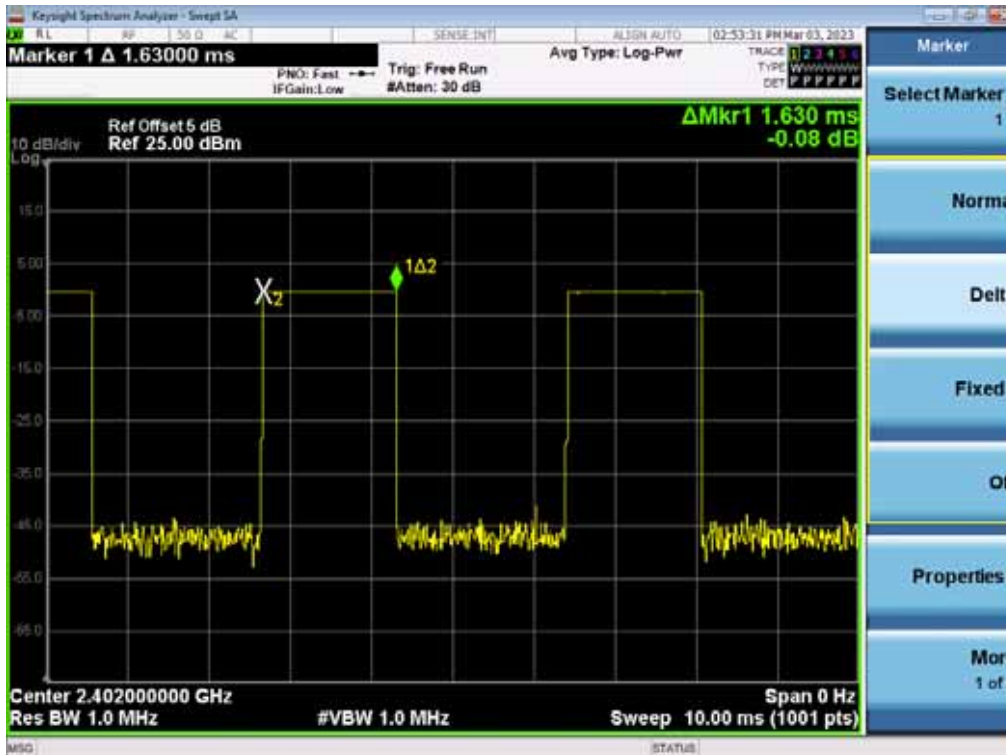

Test Data: DH3\2441MHz

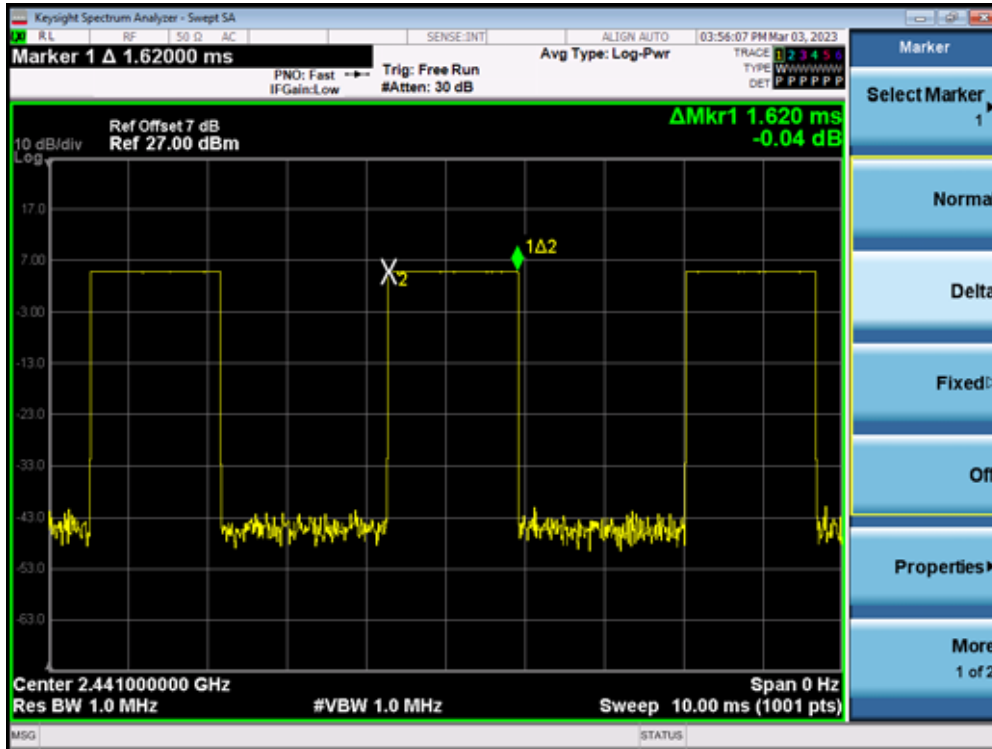

Test Data: DH3\2480MHz

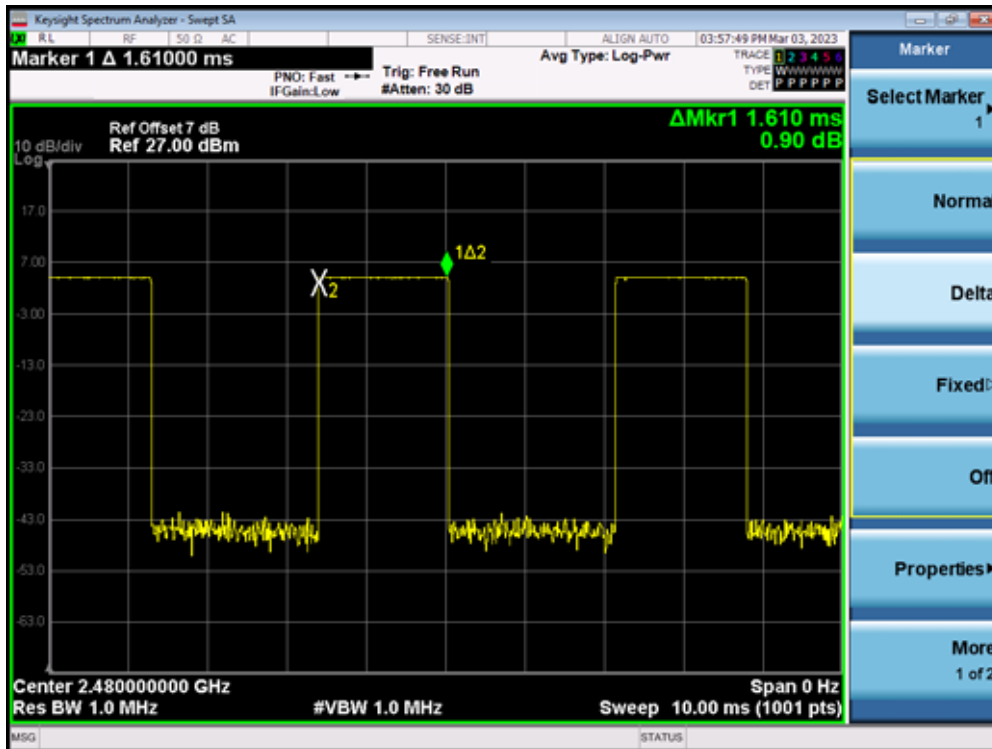

Test Data: DH5\2402MHz

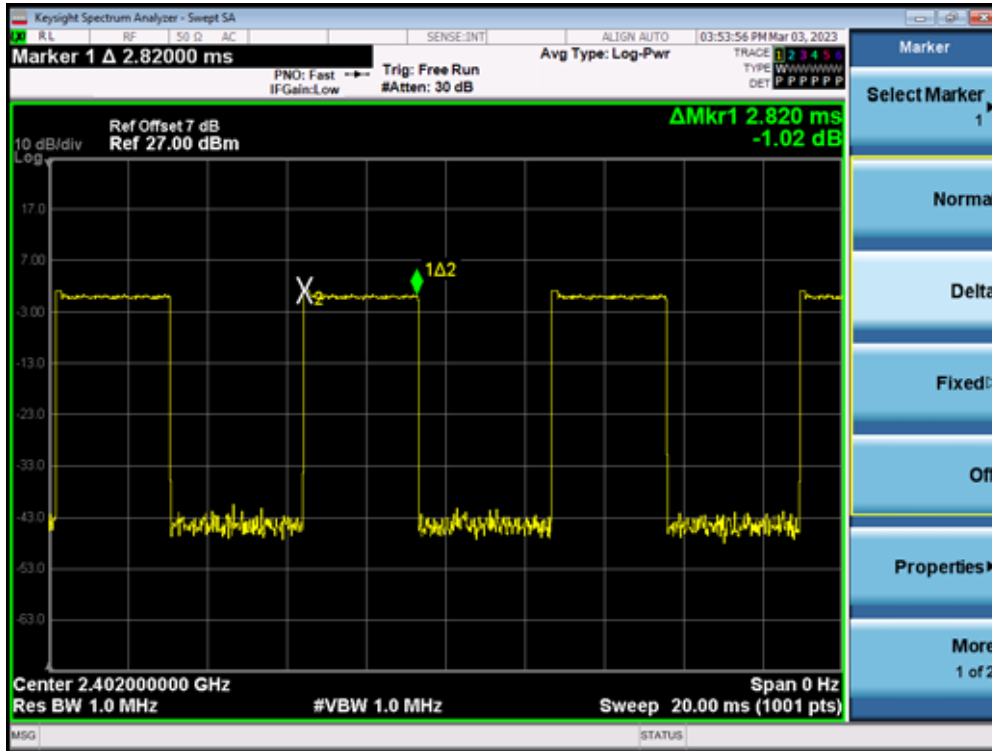

Test Data: DH5\2441MHz

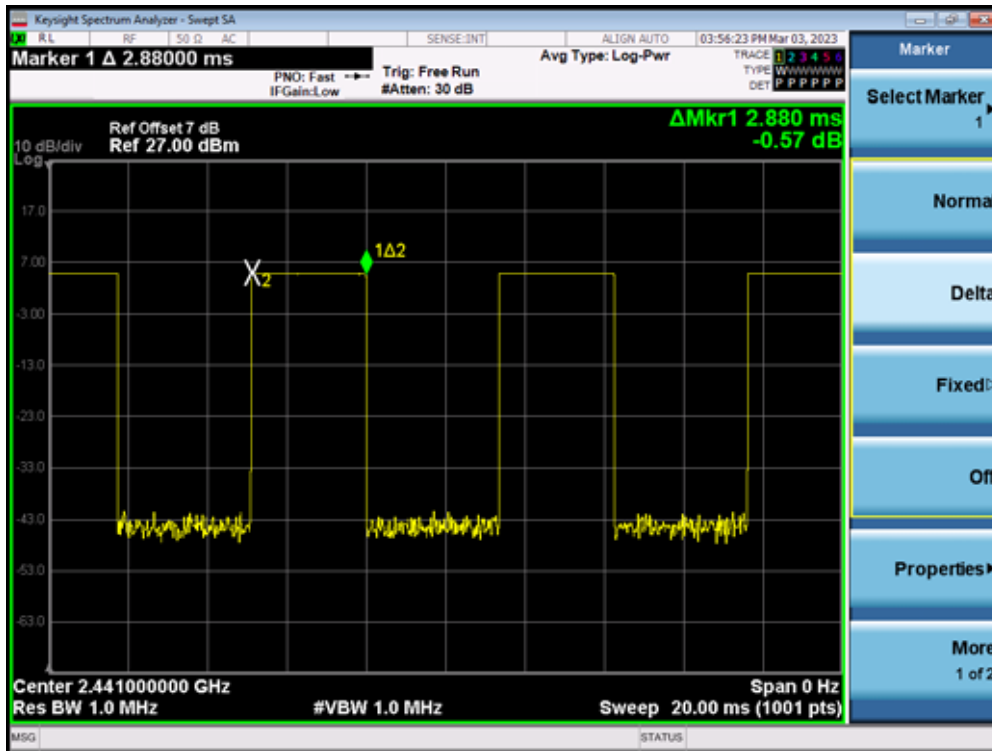

Test Data: DH5\2480MHz

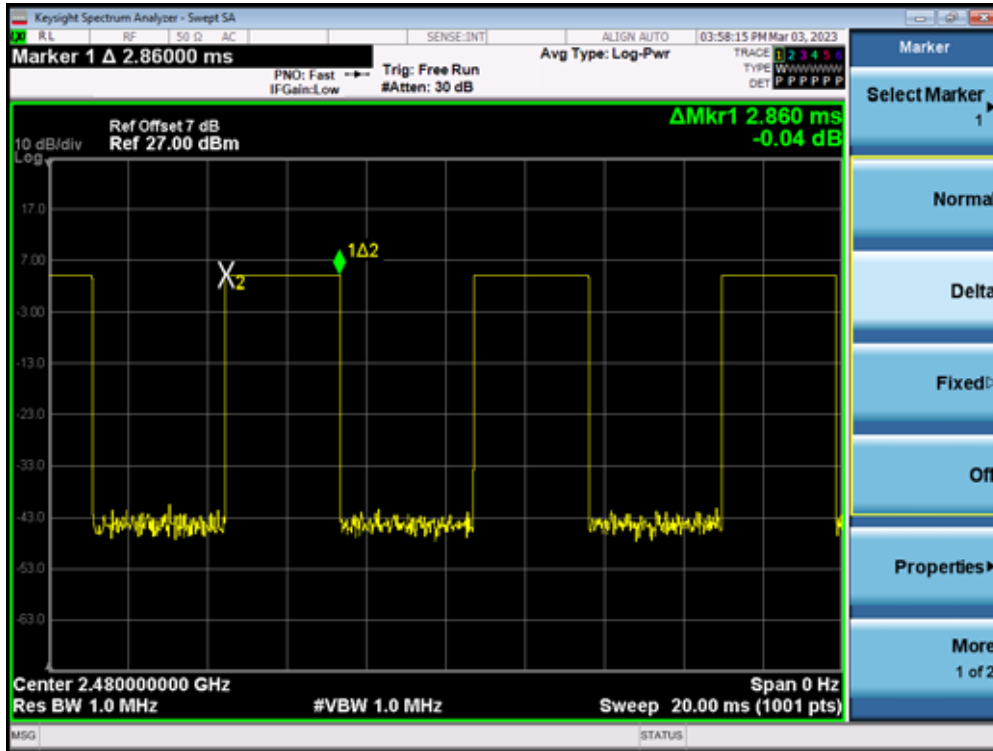

13. Appendix

13.1 Appendix A: Equipment List

Location	Equipment Name	Brand	Model	S/N	Last Cal. Date	Next Cal. Date
Conduction 02	EMI Receiver 14	ROHDE& SCHWARZ	ESCI	101034	05/25/2022	05/25/2023
Conduction 02	Conduction 02-1 Cable	WOKEN	CFD 300-NL	Conduction 02 -1	10/11/2022	10/11/2023
Conduction 02	LISN 26	R&S	ENV216	102378	12/08/2022	12/08/2023
Conduction 02	LISN 21	R&S	ENV216	101476	07/20/2022	07/20/2023
Conduction 02	ISN T4 07	Teseq GmbH	ISN T400A	30449	07/28/2022	07/28/2023
Conduction 02	ISN T8 10	TESEQ	ISN T800	42773	08/05/2022	08/05/2023
Conduction 02	CDN ISN ST08A_1	Teseq GmbH	CDN ISN ST08A	43352	10/04/2022	10/04/2023
Conduction 02	Capacitive Voltage Probe 01	SCHAFFNER	CVP 2200A	18711	02/22/2023	02/22/2024
Conduction 02	Current Probe	SCHAFFNER	SMZ 11	18030	02/22/2023	02/22/2024

Location Conducted	Equipment Name	Brand	Model	S/N	Last Cal. Date	Next Cal. Date
Chamber 19	Spectrum analyzer	R&S	FSV40	101919	08/17/2022	08/17/2023
Chamber 19	EMI Receiver	R&S	ESR3	102461	05/10/2022	05/10/2023
Chamber 19	Loop Antenna	EM	EM-6879	271	10/05/2022	10/05/2023
Chamber 19	Bilog Antenna (30MHz-1GHz)	Schwarzbeck	VULB9168 w 6dB Att.	9168-736	03/09/2023	03/09/2024
Chamber 19	Horn antenna (1GHz-18GHz)	ETS	3117	00218718	10/12/2022	10/12/2023
Chamber 19	Horn antenna (18GHz-26GHz)	Com-power	AH-826	081001	11/24/2022	11/24/2023
Chamber 19	Horn antenna (26GHz-40GHz)	Com-power	AH-640	100A	03/18/2023	03/18/2024
Chamber 19	Preamplifier (9kHz-1GHz)	HP	8447F	3113A04621	06/24/2022	06/24/2023
Chamber 19	Preamplifier (1GHz-26GHz)	HP	8449B	3008A02471	06/24/2022	06/24/2023
Chamber 19	Preamplifier (26GHz-40GHz)	MITEQ	JS4-26004000-27-5A	818471	05/12/2022	05/12/2023
Chamber 19	RF Cable (100kHz-26.5GHz)	Huber Suhner	Sucoflex 104A	MY1394/4A & 50886/4A	09/02/2022	09/02/2023
Chamber 19	RF Cable (18GHz-40GHz)	HUBER SUHNER	Sucoflex 102	27963/2&37421/2	11/23/2022	11/23/2023
Chamber 19	Signal Generator	Anritsu	MG3692A	20311	12/29/2022	12/29/2023
Chamber 19	Test Software	Audix	E3 Ver:6.120203b	N/A	N/A	N/A

Location Conducted	Equipment Name	Brand	Model	S/N	Last Cal. Date	Next Cal. Date
Conducted	Power Meter	Anritsu	ML2495A	1116010	09/29/2022	09/29/2023
Conducted	Power Sensor	Anritsu	MA2411B	34NKF50	09/29/2022	09/29/2023
Conducted	Power Sensor	DARE	RPR3006W	13I00030SNO33	01/06/2023	01/06/2024
Conducted	Power Sensor	DARE	RPR3006W	13I00030SNO34	01/06/2023	01/06/2024
Conducted	Power Sensor	DARE	RPR3006W	14I00889SNO35	06/29/2022	06/29/2023
Conducted	Power Sensor	DARE	RPR3006W	14I00889SNO36	06/29/2022	06/29/2023
Conducted	Temperature Chamber	KSON	THS-B4H100	2287	05/20/2022	05/20/2023
Conducted	DC Power supply	ABM	8185D	N/A	01/04/2023	01/04/2024
Conducted	AC Power supply	EXTECH	CFC105W	NA	N/A	N/A
Conducted	Spectrum analyzer	Keysight	N9010A	MY56070257	09/28/2022	09/28/2023
Conducted	Test Software	DARE	Radiation Ver:2013.1.23	NA	NA	NA
Conducted	Test Software	R&S	CMUGO Ver:2.0.0	N/A	N/A	N/A
Conducted	Universal Radio Comm. Tester	R&S	CMU200	111968	11/19/2022	11/19/2023
Conducted	Wideband Radio Comm. Tester	R&S	CMW500	1201.002K50108793-JG	10/31/2022	10/31/2023
Conducted	BT Simulator	Agilent	N4010A	MY48100200	NA	NA
Conducted	Signal Generator	Agilent	E4438C	MY49071550	12/28/2022	12/28/2023
Conducted	Signal Generator	Keysight	N5182B	MY53052399	12/28/2022	12/28/2023
Conducted	Spectrum analyzer	Keysight	N9010A	MY56070257	09/28/2022	09/28/2023
Conducted (TS8997)	Wideband Radio Comm. Tester	R&S	CMW500	168811	09/22/2022	09/22/2023
Conducted (TS8997)	UP/DOWN converter	R&S	CMW-Z800A	100566	12/22/2022	12/22/2023
Conducted (TS8997)	Signal Generator	R&S	SMB100A	183701	01/18/2023	01/18/2024
Conducted (TS8997)	Vector Signal Generator	R&S	SMM100A	101908	11/23/2022	11/23/2023
Conducted (TS8997)	Signal analyzer 40GHz	R&S	FSV40	101884	09/22/2022	09/22/2023
Conducted (TS8997)	OSP150 extension unit CAM-BUS	R&S	OSP150	101107	09/21/2022	09/21/2023
Conducted (TS8997)	Test Software	R&S	EMC32 Ver: 11.50.00	NA	NA	NA

13.2 Appendix B: Uncertainty of Measurement

ISO/IEC 17025 requires that an estimate of measurement uncertainties associated with the emissions test results be included in the report. The measurement uncertainties given below are based on a 95% confidence level (based on a coverage factor (k=2)).

Description Of Test	Uncertainty
Conducted Emission (AC power line)	2.586 dB
Field Strength of Spurious Radiation	≤30MHz: 2.96dB 30-1GHz: 4.22 dB 1-40 GHz: 4.08 dB
Conducted Power	2.412 GHz: 1.30 dB
Power Density	2.412 GHz:1.30 dB
Frequency	0.0032%
Time	0.01%
DC Voltage	1%

13.3 Appendix C: Test Setup

AC Line Conducted Emission Test Setup

1. The conducted emission tests were performed in the test site, using the setup in accordance with the ANSI C63.10-2013.
2. The AC/DC Power adaptor of EUT was plug-in LISN. The EUT was placed flushed with the rear of the table.
3. The LISN was connected with 120Vac/60Hz power source.

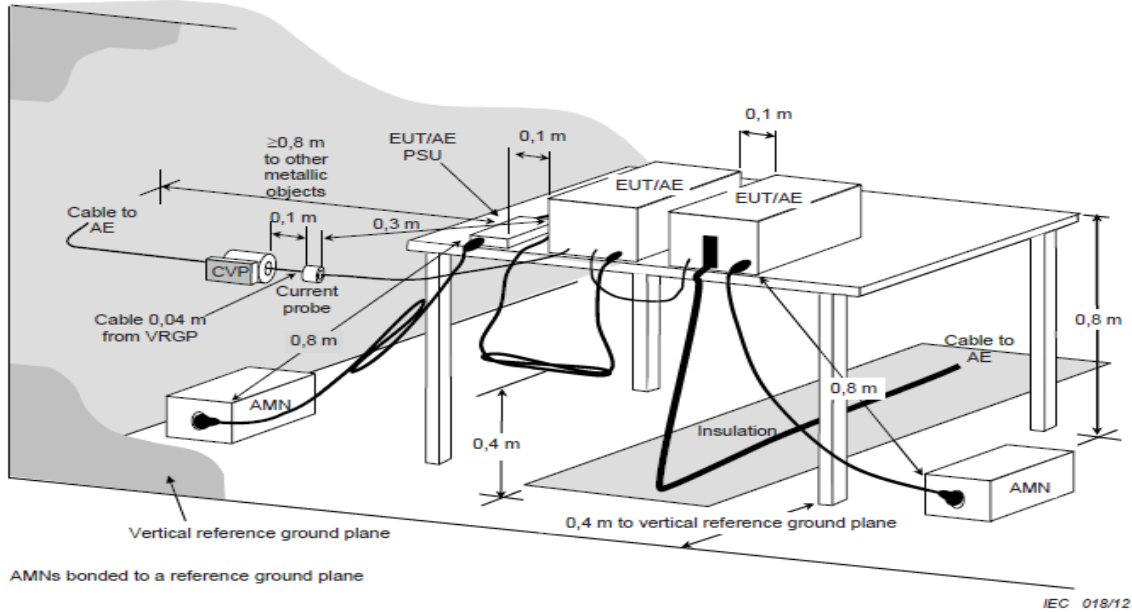

Radiated Spurious Emission Test & 100kHz Bandwidth of Band Edges Measurement Test Setup

(A) Radiated Emission Test Setup for frequency below 1000MHz

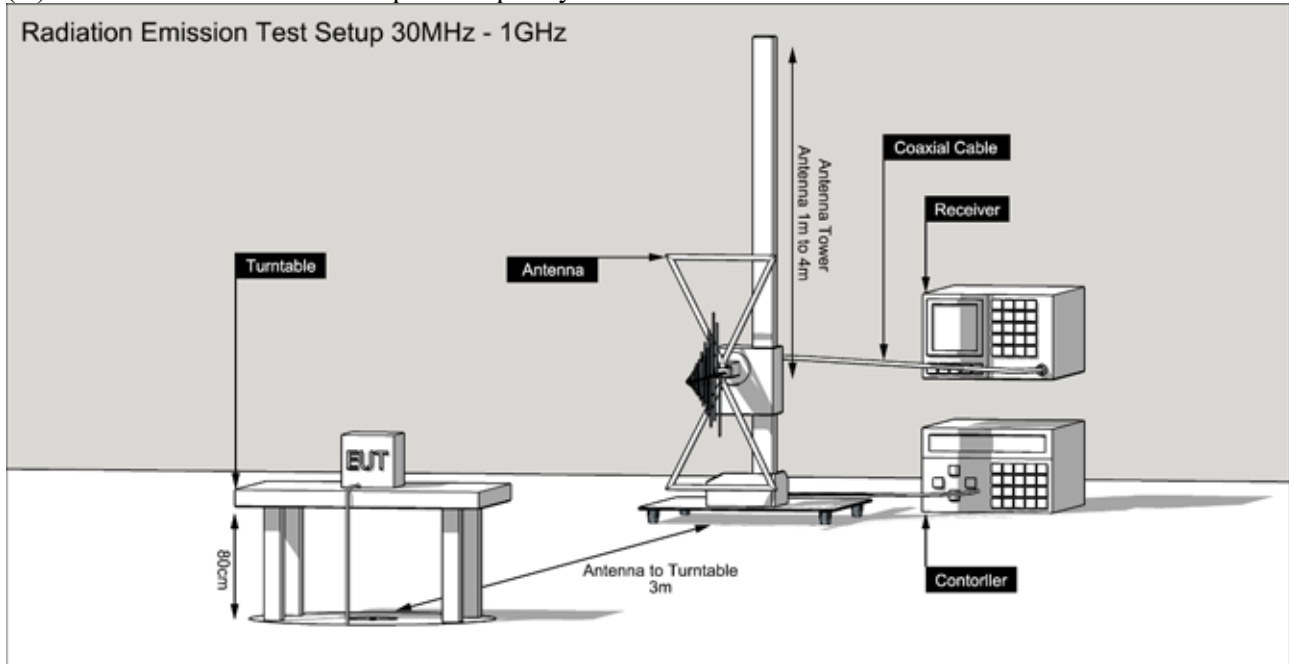

(B) Radiated Emission Test Setup for frequency above 1 GHz

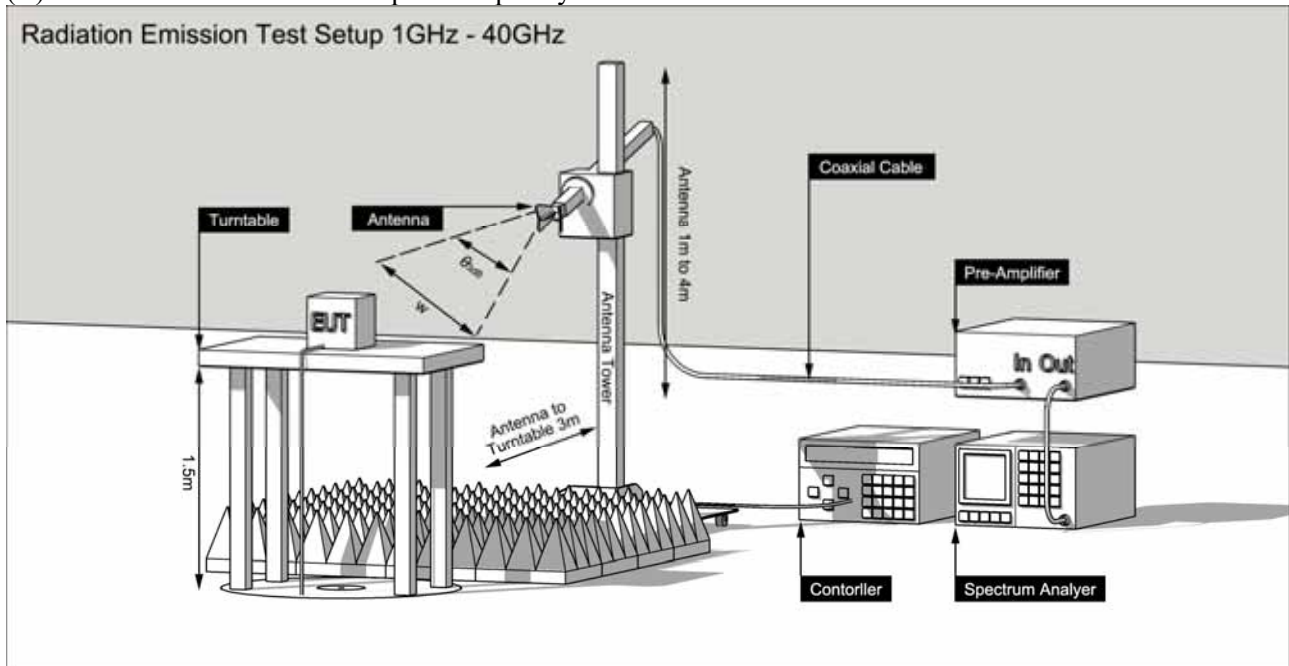

RF Conducted Measurement Test Setup

