

# TEST REPORT

**Product Name** : Integrated RFID Reader  
**Model Number** : HF100, HH100  
**FCC ID** : 2ANBW-HF100

Prepared for : SHENZHEN HOPELAND TECHNOLOGIES CO., LTD.  
Address : 17/F, Block A, Clou Bldg, Baoshen Road, Hitech Industrial  
Park North, Nanshan District, 518007, Shenzhen, China

Prepared by : EMTEK (SHENZHEN) CO., LTD.  
Address : Building 69, Majialong Industry Zone, Nanshan District,  
Shenzhen, Guangdong, China

Tel: (0755) 26954280  
Fax: (0755) 26954282

Report Number : ENS2110210074W00501R  
Date(s) of Tests : October 21, 2021 to December 2, 2021  
Date of issue : December 2, 2021

二维码

## Table of Contents

TEST REPORT.....	1
1 TEST RESULT CERTIFICATION.....	3
2 EUT TECHNICAL DESCRIPTION.....	4
3 SUMMARY OF TEST RESULT.....	5
4 TEST METHODOLOGY.....	6
4.1 GENERAL DESCRIPTION OF APPLIED STANDARDS.....	6
4.2 MEASUREMENT EQUIPMENT USED.....	6
4.3 DESCRIPTION OF TEST MODES.....	7
5 FACILITIES AND ACCREDITATIONS.....	8
5.1 FACILITIES.....	8
5.2 LABORATORY ACCREDITATIONS AND LISTINGS.....	8
6 TEST SYSTEM UNCERTAINTY.....	9
7 SETUP OF EQUIPMENT UNDER TEST.....	10
7.1 RADIO FREQUENCY TEST SETUP 1.....	10
7.2 RADIO FREQUENCY TEST SETUP 2.....	10
7.3 CONDUCTED EMISSION TEST SETUP.....	12
7.4 BLOCK DIAGRAM CONFIGURATION OF TEST SYSTEM.....	13
7.5 SUPPORT EQUIPMENT.....	13
8 TEST REQUIREMENTS.....	14
8.1 20DB BANDWIDTH.....	14
8.2 CARRIER FREQUENCY SEPARATION.....	17
8.3 NUMBER OF HOPPING FREQUENCIES.....	20
8.4 AVERAGE TIME OF OCCUPANCY (DWELL TIME).....	22
8.5 MAXIMUM PEAK CONDUCTED OUTPUT POWER.....	24
8.6 CONDUCTED SUPRIIOUS EMISSION.....	27
8.7 RADIATED SPURIOUS EMISSION.....	34
8.8 CONDUCTED EMISSION TEST.....	44
8.9 ANTENNA APPLICATION.....	47

# 1 TEST RESULT CERTIFICATION

Applicant:	SHENZHEN HOPELAND TECHNOLOGIES CO., LTD.
Address:	17/F, Block A, Clou Bldg, Baoshen Road, Hitech Industrial Park North, Nanshan District, 518007, Shenzhen, China
Manufacturer:	SHENZHEN HOPELAND TECHNOLOGIES CO., LTD.
Address:	17/F, Block A, Clou Bldg, Baoshen Road, Hitech Industrial Park North, Nanshan District, 518007, Shenzhen, China
Product Description:	Integrated RFID Reader
Model Number:	HF100, HH100
Trademark:	

Measurement Procedure Used:

APPLICABLE STANDARDS	
STANDARD	TEST RESULT
FCC 47 CFR Part 2, Subpart J FCC 47 CFR Part 15, Subpart C	PASS

The above equipment was tested by EMTEK(SHENZHEN) CO., LTD. The test data, data evaluation, test procedures, and equipment configurations shown in this report were made in accordance with the procedures given in ANSI C63.10 (2013) and the energy emitted by the sample EUT tested as described in this report is in compliance with the requirements of FCC Rules Part 2 and Part 15.247

The test results of this report relate only to the tested sample identified in this report

Date of Test : October 21, 2021 to December 2, 2021

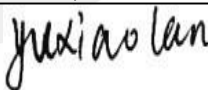
Prepared by :   
Yu Xiaolan/Editor

Reviewer :   
Joe Xia/Supervisor

Approve & Authorized Signer :   
Lisa Wang/Manager



## 2 EUT TECHNICAL DESCRIPTION

Characteristics	Description
<b>Product :</b>	Integrated RFID Reader
<b>Model Number :</b>	HF100, HH100 (Note: All models are identical in circuitry and electrical, mechanical and physical construction; the difference are the appearance and model number for trading purpose, we prepared HF100 for test.)
<b>Modulation:</b>	PR-ASK, DSB-ASK
<b>Operating Frequency :</b>	902.75MHz~927.25MHz
<b>Number of Channels:</b>	50
<b>Transmit Power Max:</b>	17.47 dBm
<b>Antenna Type :</b>	External Antenna
<b>Antenna Gain:</b>	9 dBi
<b>Power supply:</b>	Adapter: Model: FSP060-DAAN2 Input: 100~240V, 50/60Hz, 1.5A Output: 24V/2.5A Max

**Note:** for more details, please refer to the User's manual of the EUT.

### 3 SUMMARY OF TEST RESULT

FCC Part Clause	Test Parameter	Verdict	Remark
15.247(a)(1)	20 dB Bandwidth	PASS	
15.247(a)(1)	Carrier Frequency Separation	PASS	
15.247(a)(1)	Number of Hopping Frequencies	PASS	
15.247(a)(1)	Average Time of Occupancy (Dwell Time)	PASS	
15.247(b)(1)	Maximum Peak Conducted Output Power	PASS	
15.247(c)	Conducted Spurious Emissions	PASS	
15.247(d) 15.209	Radiated Spurious Emissions	PASS	
15.207	Conducted Emission	PASS	
15.203	Antenna Application	PASS	
NOTE: N/A (Not Applicable)			

#### RELATED SUBMITTAL(S) / GRANT(S):

This submittal(s) (test report) is intended for FCC ID: 2ANBW-HF100 filing to comply with Section 15.247 of the FCC Part 15, Subpart C Rules.

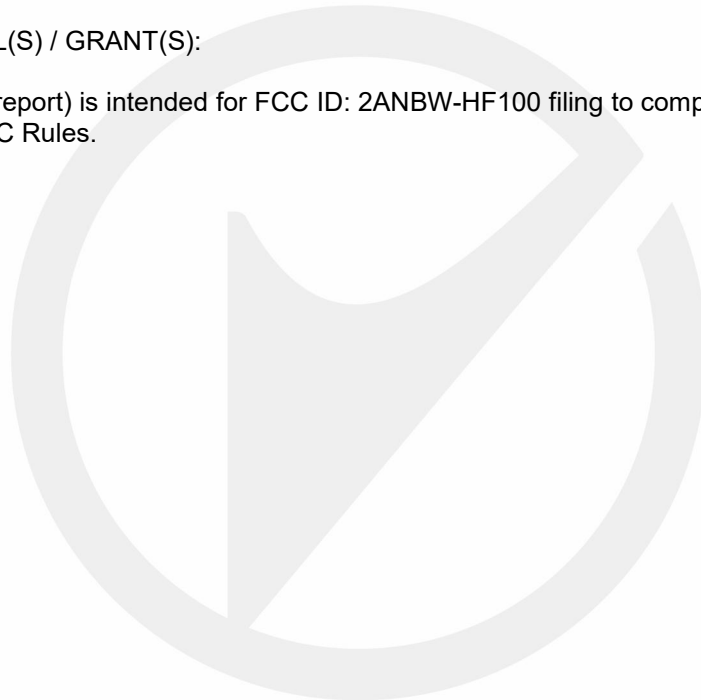

## 4 TEST METHODOLOGY

### 4.1 GENERAL DESCRIPTION OF APPLIED STANDARDS

According to its specifications, the EUT must comply with the requirements of the following standards:

FCC 47 CFR Part 2, Subpart J

FCC 47 CFR Part 15, Subpart C

KDB 558074: D01 15.247 Meas Guidance v05r02

### 4.2 MEASUREMENT EQUIPMENT USED

#### 4.2.1 Conducted Emission Test Equipment

EQUIPMENT TYPE	MFR	MODEL NUMBER	SERIAL NUMBER	LAST CAL.
Test Receiver	Rohde & Schwarz	ESCI	101045	2021/5/15
L.I.S.N.	Schwarzbeck	NNLK8129	8129203	2021/5/15
50Ω Coaxial Switch	Anritsu	MP59B	M20531	2021/5/15
Pulse Limiter	Rohde & Schwarz	ESH3-Z2	100107	2021/5/15
Voltage Probe	Rohde & Schwarz	TK9416	N/A	2021/5/15
I.S.N	TESEQ	ISN T800	30327	2021/3/19

#### 4.2.2 Radiated Emission Test Equipment

EQUIPMENT TYPE	MFR	MODEL NUMBER	SERIAL NUMBER	LAST CAL.
EMI Test Receiver	Rohde & Schwarz	ESCI	101414	2021/5/15
Pre-Amplifier	HP	8447D	2944A07999	2021/5/15
Bilog Antenna	Schwarzbeck	VULB9163	712	2021/7/5
Loop Antenna	Schwarzbeck	FMZB1519	1519-012	2021/6/12
Horn Antenna	Schwarzbeck	BBHA 9170	9170-399	2021/6/12
Horn Antenna	Schwarzbeck	BBHA9120D	9120D-1178	2021/6/12
Cable	Schwarzbeck	AK9513	ACRX1	2021/5/15
Cable	Rosenberger	N/A	FP2RX2	2021/5/15
Cable	Schwarzbeck	AK9513	CRPX1	2021/5/15
Cable	Schwarzbeck	AK9513	CRRX2	2021/5/15

#### 4.2.3 Radio Frequency Test Equipment

EQUIPMENT TYPE	MFR	MODEL NUMBER	SERIAL NUMBER	LAST CAL.
Spectrum Analyzer	Rohde & Schwarz	FSV30	103039	2021/5/15
Power meter	\	PS-X10-100	\	2021/5/15
Power sensor	Anritsu	MA2411B	0738172	2021/5/15
Signal Analyzer	Agilent	N9010A	My53470879	2021/5/16

**Remark:** Each piece of equipment is scheduled for calibration once a year.

### 4.3 DESCRIPTION OF TEST MODES

The EUT has been tested under its typical operating condition.

The EUT configuration for testing is installed on RF field strength measurement to meet the Commissions requirement and operating in a manner which intends to maximize its emission characteristics in a continuous normal application.

The Transmitter was operated in the normal operating mode. The TX frequency was fixed which was for the purpose of the measurements.

Test of channel included the lowest and middle and highest frequency to perform the test, then record on this report.

Those channels (902.75MHz, 915.25MHz, 927.25MHz) were used for all test.

Pre-defined engineering program for regulatory testing used to control the EUT for staying in continuous transmitting and receiving mode is programmed.

Frequency and Channel list for the EUT:

Channel	Frequency (MHz)	Channel	Frequency (MHz)	Channel	Frequency (MHz)
<b>1</b>	<b>902.75</b>	24	914.25	47	925.75
2	903.25	25	914.75	48	926.25
3	903.75	<b>26</b>	<b>915.25</b>	49	926.75
...	...	...	...	<b>50</b>	<b>927.25</b>
Note: $f_c=902.75\text{MHz}+k*0.5\text{MHz}$ $k(\text{Channel Number})=1$ to 50					

Test Frequency and channel for the EUT:

Lowest Frequency		Middle Frequency		Highest Frequency	
Channel	Frequency (MHz)	Channel	Frequency (MHz)	Channel	Frequency (MHz)
01	902.75	26	915.25	50	927.25

## 5 FACILITIES AND ACCREDITATIONS

### 5.1 FACILITIES

All measurement facilities used to collect the measurement data are located at

Building 69, Majialong Industry Zone District, Nanshan District, Shenzhen, China

The sites are constructed in conformance with the requirements of ANSI C63.7, ANSI C63.10 and CISPR Publication 22.

### 5.2 LABORATORY ACCREDITATIONS AND LISTINGS

Site Description

EMC Lab.

: **Accredited by CNAS**

The Certificate Registration Number is L2291.

The Laboratory has been assessed and proved to be in compliance with CNAS-CL01 (identical to ISO/IEC 17025:2017)

**Accredited by FCC**

Designation Number: CN1204

Test Firm Registration Number: 882943

**Accredited by A2LA**

The Certificate Number is 4321.01.

**Accredited by Industry Canada**

The Conformity Assessment Body Identifier is CN0008

Name of Firm

: EMTEK (SHENZHEN) CO., LTD.

Site Location

: Building 69, Majialong Industry Zone,  
Nanshan District, Shenzhen, Guangdong, China



## 6 TEST SYSTEM UNCERTAINTY

The following measurement uncertainty levels have been estimated for tests performed on the apparatus:

Parameter	Uncertainty
Radio Frequency	$\pm 1 \times 10^{-5}$
Maximum Peak Output Power Test	$\pm 1.0\text{dB}$
Conducted Emissions Test	$\pm 2.0\text{dB}$
Radiated Emission Test	$\pm 2.0\text{dB}$
Occupied Bandwidth Test	$\pm 1.0\text{dB}$
Band Edge Test	$\pm 3\text{dB}$
All emission, radiated	$\pm 3\text{dB}$
Antenna Port Emission	$\pm 3\text{dB}$
Temperature	$\pm 0.5^\circ\text{C}$
Humidity	$\pm 3\%$

Measurement Uncertainty for a level of Confidence of 95%



## 7 SETUP OF EQUIPMENT UNDER TEST

### 7.1 RADIO FREQUENCY TEST SETUP 1

The RFID component's antenna ports(s) of the EUT are connected to the measurement instrument per an appropriate attenuator. The EUT is controlled by PC/software to emit the specified signals for the purpose of measurements.

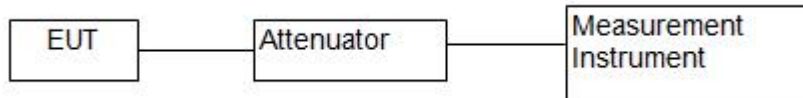

### 7.2 RADIO FREQUENCY TEST SETUP 2

The test site semi-anechoic chamber has met the requirement of NSA tolerance 4 dB according to the standards: ANSI C63.10. The test distance is 3m. The setup is according to the requirements in Section 13.1.4.1 of ANSI C63.10-2013 and CAN/CSA-CEI/IEC CISPR 22.

Below 30MHz:

The EUT is placed on a turntable 0.8 meters above the ground in the chamber, 3 meter away from the antenna (loop antenna). The Antenna should be positioned with its plane vertical at the specified distance from the EUT and rotated about its vertical axis for maximum response at each azimuth about the EUT. The center of the loop shall be 1 m above the ground. For certain applications, the loop antenna plane may also need to be positioned horizontally at the specified distance from the EUT.

Above 30MHz:

The EUT is placed on a turntable 0.8 meters above the ground in the chamber, 3 meter away from the antenna. The maximal emission value is acquired by adjusting the antenna height, polarisation and turntable azimuth. Normally, the height range of antenna is 1 m to 4 m, the azimuth range of turntable is 0° to 360°, and the receive antenna has two polarizations Vertical (V) and Horizontal (H).

Above 1GHz:

The EUT is placed on a turntable 1.5 meters above the ground in the chamber, 3 meter away from the antenna. The maximal emission value is acquired by adjusting the antenna height, polarisation and turntable azimuth. Normally, the height range of antenna is 1 m to 4 m, the azimuth range of turntable is 0° to 360°, and the receive antenna has two polarizations Vertical (V) and Horizontal (H).

(a) Radiated Emission Test Set-Up, Frequency Below 30MHz

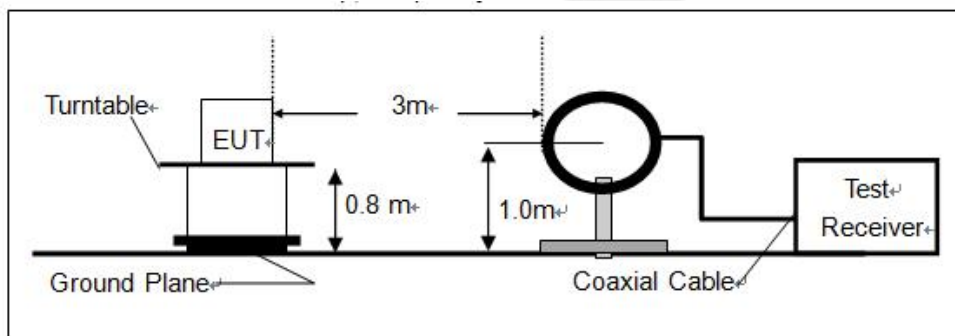

(b) Radiated Emission Test Set-Up, Frequency Below 1000MHz

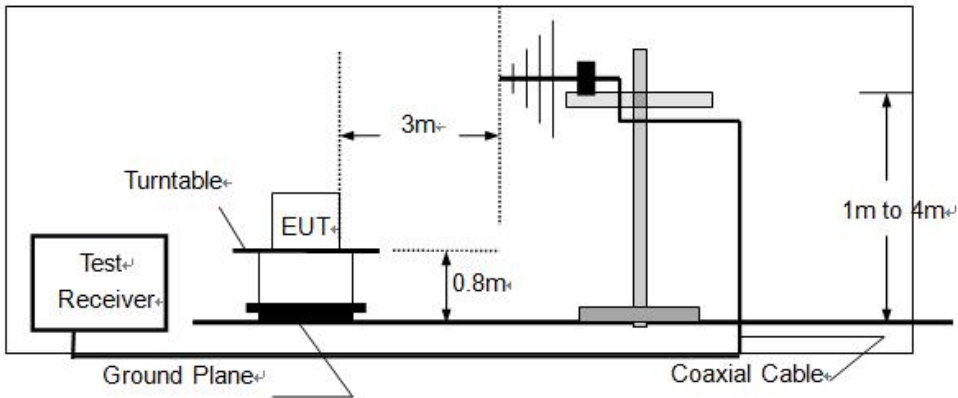

(c) Radiated Emission Test Set-Up, Frequency above 1000MHz

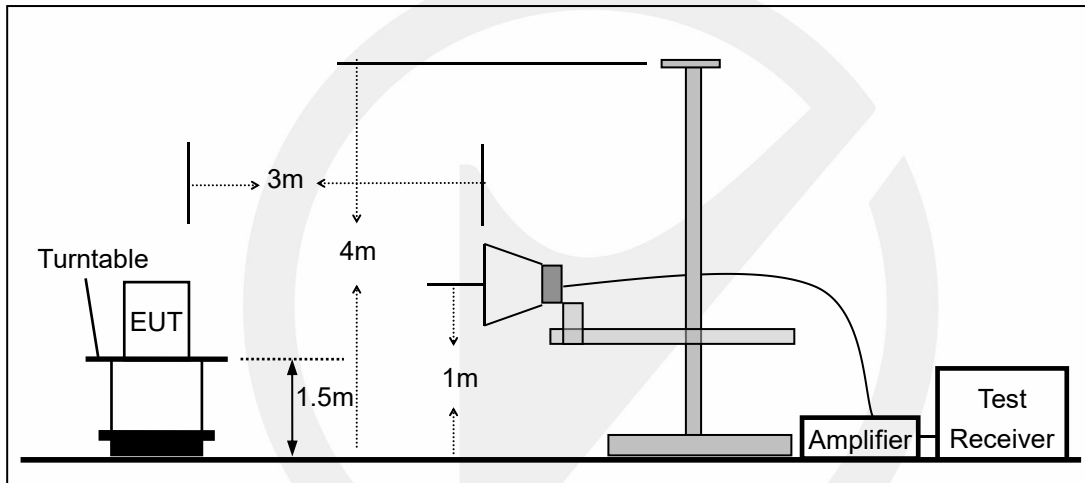

**7.3 CONDUCTED EMISSION TEST SETUP**

The mains cable of the EUT (UHF RFID Reader Module) must be connected to LISN. The LISN shall be placed 0.8 m from the boundary of EUT and bonded to a ground reference plane for LISN mounted on top of the ground reference plane. This distance is between the closest points of the LISN and the EUT. All other units of the EUT and associated equipment shall be at least 0.8m from the LISN.

Ground connections, where required for safety purposes, shall be connected to the reference ground point of the LISN and, where not otherwise provided or specified by the manufacturer, shall be of same length as the mains cable and run parallel to the mains connection at a separation distance of not more than 0.8 m.

According to the requirements in Section 13.1.4.1 of ANSI C63.10-2013 Conducted emissions from the EUT measured in the frequency range between 0.15 MHz and 30 MHz using CISPR Quasi-Peak and average detector mode.

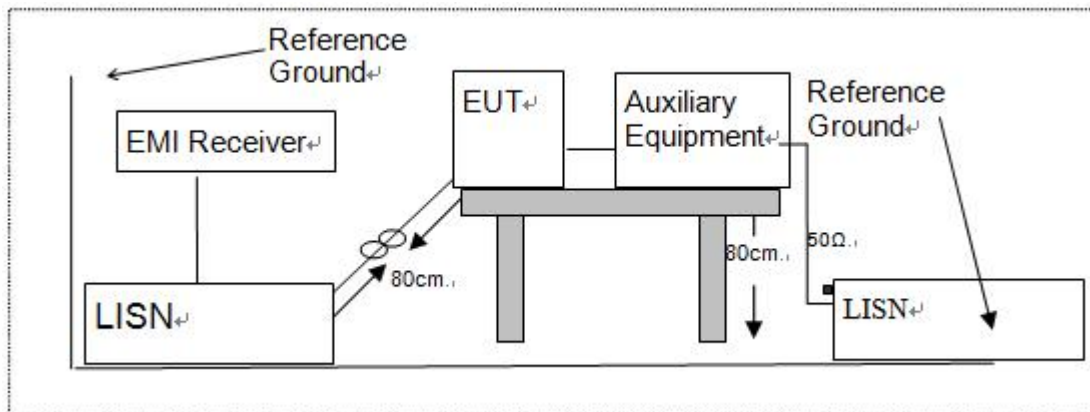

**7.4 BLOCK DIAGRAM CONFIGURATION OF TEST SYSTEM**

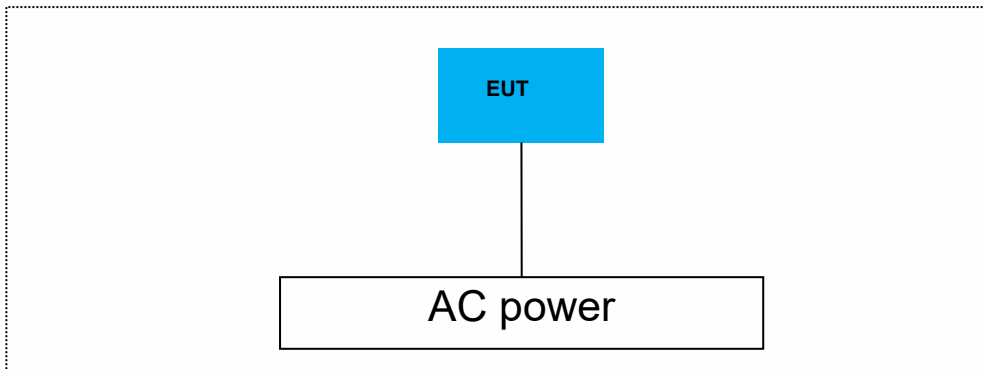

**7.5 SUPPORT EQUIPMENT**

EUT Cable List and Details			
Cable Description	Length (m)	Shielded/Unshielded	With / Without Ferrite
/	/	/	/

Auxiliary Cable List and Details			
Cable Description	Length (m)	Shielded/Unshielded	With / Without Ferrite
/	/	/	/

Auxiliary Equipment List and Details			
Description	Manufacturer	Model	Serial Number
/	/	/	/

**Notes:**

1. All the equipment/cables were placed in the worst-case configuration to maximize the emission during the test.
2. Grounding was established in accordance with the manufacturer’s requirements and conditions for the intended use.

## 8 TEST REQUIREMENTS

### 8.1 20DB BANDWIDTH

#### 8.1.1 Applicable Standard

According to FCC Part 15.247(a)(1) and KDB 558074: D01 15.247 Meas Guidance v05r02

#### 8.1.2 Conformance Limit

No limit requirement.

#### 8.1.3 Test Configuration

Test according to clause 7.1 radio frequency test setup 1

#### 8.1.4 Test Procedure

The EUT was operating in RFID mode and controlled its channel. Printed out the test result from the spectrum by hard copy function.

The RF output of EUT was connected to the spectrum analyzer by RF cable and attenuator. The path loss was compensated to the results for each measurement.

Set to the maximum power setting and enable the EUT transmit continuously

Set RBW  $\geq$  1% of the 20 dB bandwidth(3KHz)

Set the video bandwidth (VBW)  $\geq$  RBW(10KHz).

Set Span= approximately 2 to 3 times the 20 dB bandwidth

Set Detector = Peak.

Set Trace mode = max hold.

Set Sweep = auto couple.

The EUT should be transmitting at its maximum data rate. Allow the trace to stabilize. Use the marker-to-peak function to set the marker to the peak of the emission. Use the marker-delta function to measure 20 dB down one side of the emission. Reset the markerdelta function, and move the marker to the other side of the emission, until it is (as close as possible to) even with the reference marker level. The marker-delta reading at this point is the 20 dB bandwidth of the emission.

If this value varies with different modes of operation (e.g., data rate, modulation format, etc.), repeat this test for each variation.

Measure and record the results in the test report.

#### Test Results

Temperature:	26° C
Relative Humidity:	54%
ATM Pressure:	1011 mbar

Modulation Mode	Channel Number	Channel Frequency (MHz)	Measurement Bandwidth (kHz)	Limit (kHz)	Verdict
ASK	01	902.75	52.10	$\leq$ 250	PASS
	26	915.25	52.53	$\leq$ 250	PASS
	50	927.25	52.97	$\leq$ 250	PASS

Note: N/A (Not Applicable).

Test Model 20dB Bandwidth  
RFID  
Channel 1: 902.75MHz

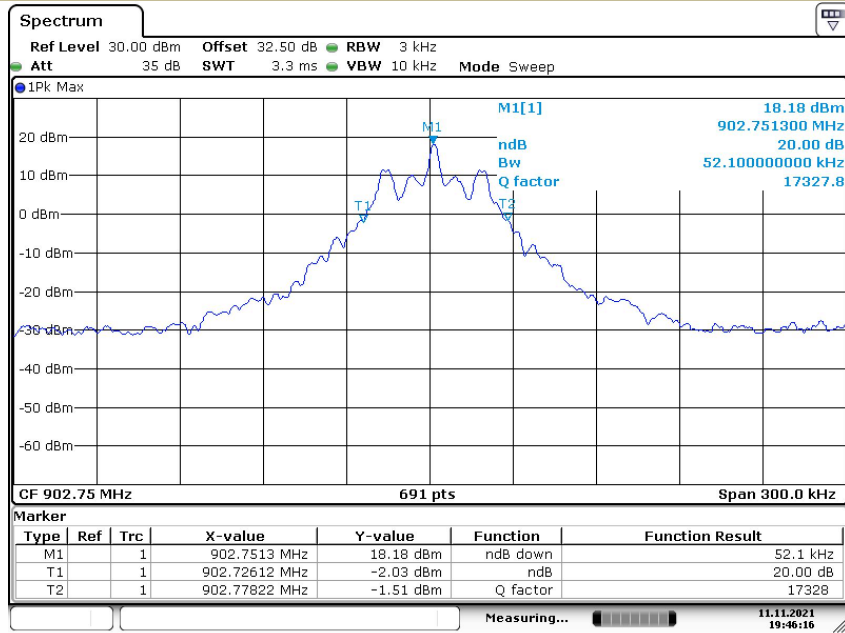

Date: 11.NOV.2021 19:46:16

Test Model 20dB Bandwidth  
RFID  
Channel 26: 915.25MHz

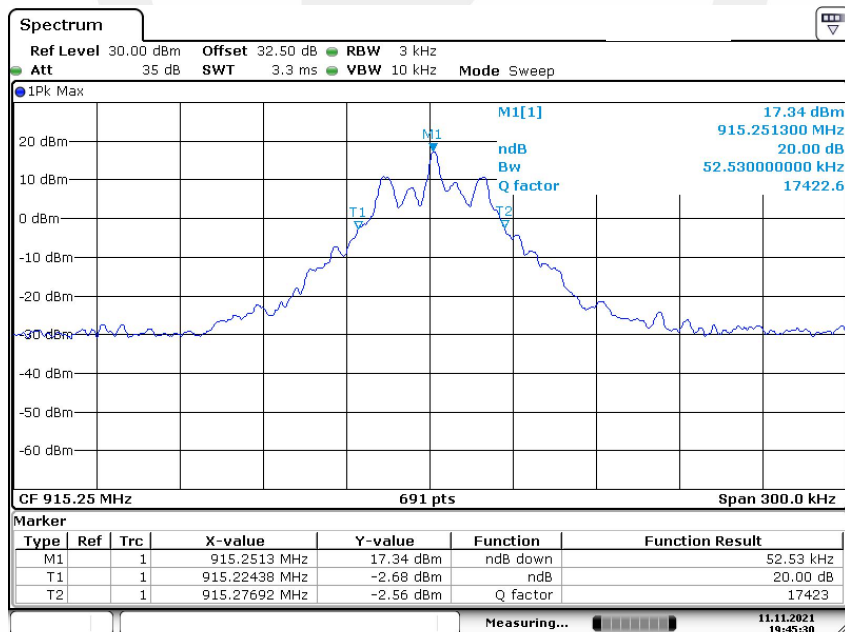

Date: 11.NOV.2021 19:45:31

Test Model 20dB Bandwidth  
RFID  
Channel 50: 927.25MHz

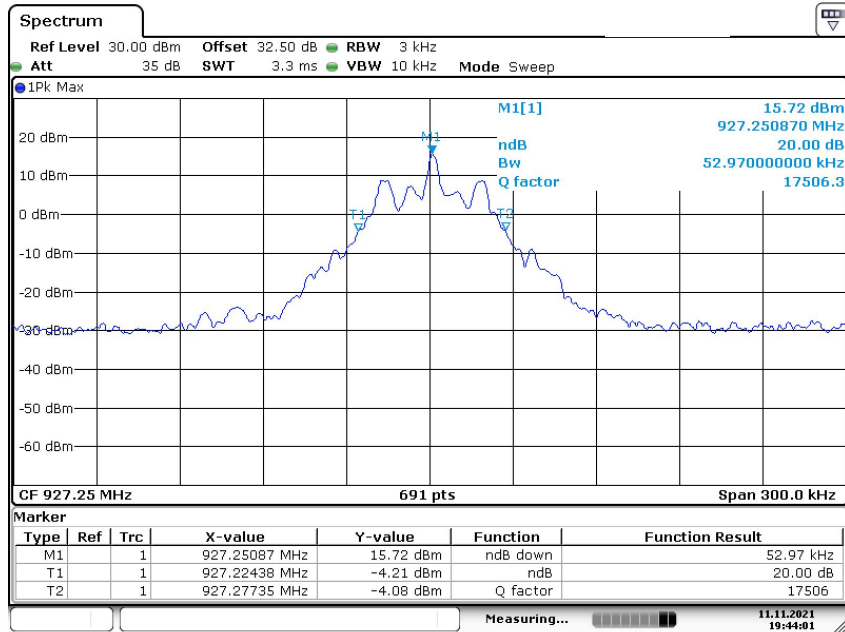

Date: 11.NOV.2021 19:44:01





## 8.2 CARRIER FREQUENCY SEPARATION

### 8.2.1 Applicable Standard

According to FCC Part 15.247(a)(1) and KDB 558074: D01 15.247 Meas Guidance v05r02

### 8.2.2 Conformance Limit

Frequency hopping systems operating in the 902-928MHz band shall have hopping channel carrier frequencies separated by a minimum of 25kHz or the 20dB bandwidth of the hopping channel, whichever is greater. In case of an output power less than 125mW, the frequency hopping system may have channels separated by a minimum of 25kHz or two-thirds of the 20dB bandwidth of the hopping channel, whichever is greater.

### 8.2.3 Test Configuration

Test according to clause 7.1 radio frequency test setup 1

### 8.2.4 Test Procedure

- According to FCC Part 15.247(a)(1)  
The EUT must have its hopping function enabled. Use the following spectrum analyzer settings:  
Set the RBW  $\geq$  1% of the span(100KHz).  
Set the VBW  $\geq$  RBW(300KHz).  
Set the span = wide enough to capture the peaks of two adjacent channels  
Set Sweep time = auto couple.  
Set Detector = peak.  
Set Trace mode = max hold.  
Allow the trace to stabilize. Use the marker-delta function to determine the separation between the peaks of the adjacent channels. The limit is specified in one of the subparagraphs of this Section. Submit this plot.

### Test Results

Temperature:	26° C
Relative Humidity:	54%
ATM Pressure:	1011 mbar

Modulation Mode	Channel Number	Channel Frequency (MHz)	Measurement Bandwidth (kHz)	Limit (kHz)	Verdict
ASK	01	902.75	502.2	>52.10	PASS
	26	915.25	497.8	>52.53	PASS
	50	927.25	505.1	>52.97	PASS
Note: Limit = 20dB bandwidth.					

**Carrier Frequency Separation**  
**RFID**  
**Channel 1: 902.75MHz**

Test Model

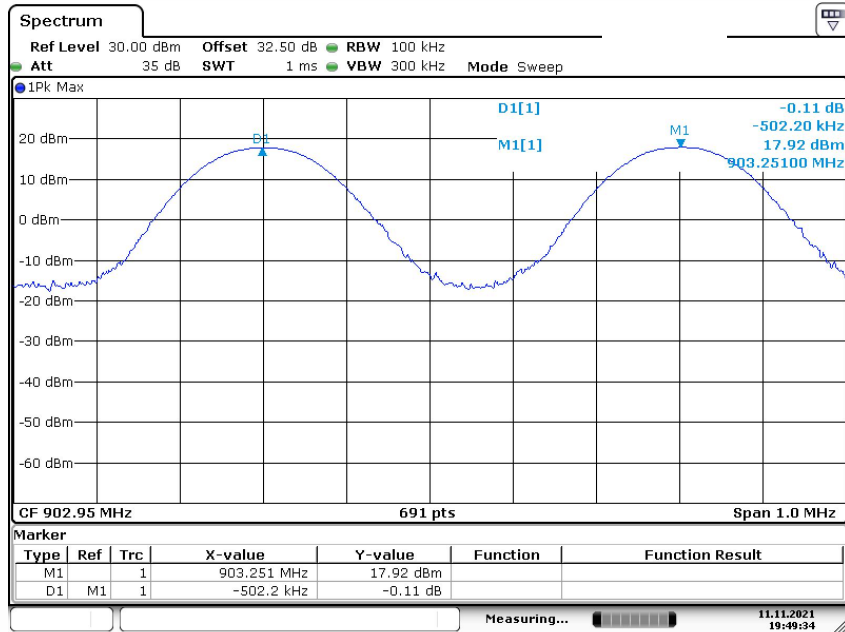

Date: 11.NOV.2021 19:49:34

**Carrier Frequency Separation**  
**RFID**  
**Channel 26: 915.25MHz**

Test Model

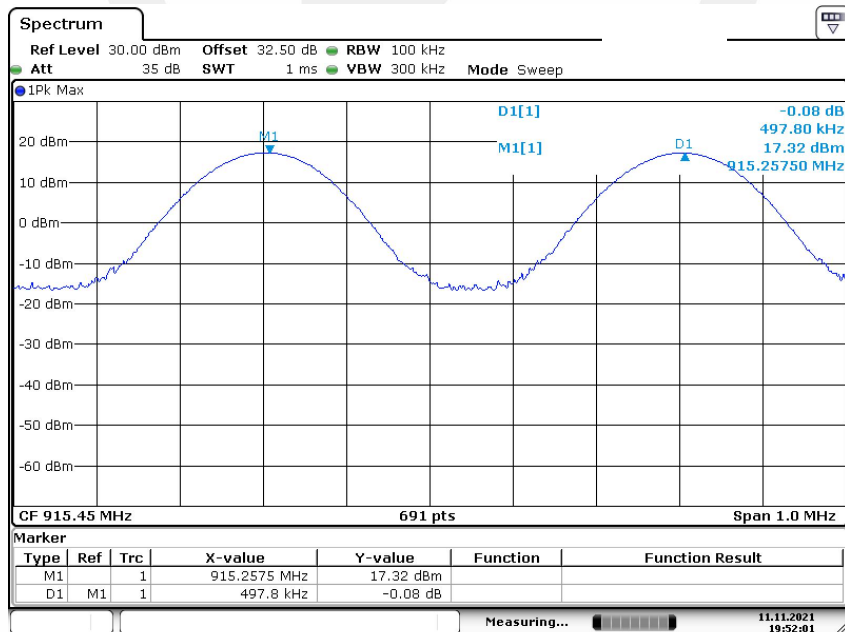

Date: 11.NOV.2021 19:52:01

**Carrier Frequency Separation**  
**RFID**  
**Channel 50: 927.25MHz**

Test Model

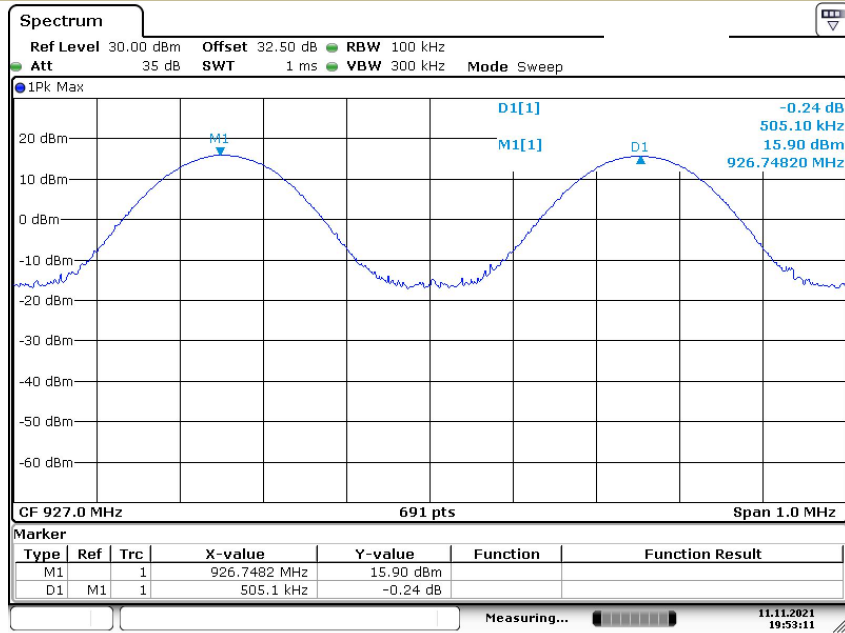

Date: 11.NOV.2021 19:53:11



### 8.3 NUMBER OF HOPPING FREQUENCIES

#### 8.3.1 Applicable Standard

According to FCC Part 15.247(a)(1) (i)and KDB 558074: D01 15.247 Meas Guidance v05r02

#### 8.3.2 Conformance Limit

Frequency hopping systems operating in the 902-928MHz band shall use at least 50 channels.

#### 8.3.3 Test Configuration

Test according to clause 7.1 radio frequency test setup 1

#### 8.3.4 Test Procedure

- According to FCC Part15.247(a)(1)(iii)

The EUT must have its hopping function enabled. Use the following spectrum analyzer settings:

Span = the frequency band of operation

RBW  $\geq$  1% of the span(100KHz).

VBW  $\geq$  RBW(300KHz).

Sweep = auto

Detector function = peak

Trace = max hold

Allow the trace to stabilize. It may prove necessary to break the span up to sections, in order to clearly show all of the hopping frequencies.

#### Test Results

Temperature:	26° C
Relative Humidity:	54%
ATM Pressure:	1011 mbar

Hopping Channel Frequency Range	Quantity of Hopping Channel	Quantity of Hopping Channel limit
902-928	50	$\geq$ 50

Test Model      Number Of Hopping Frequencies  
RFID

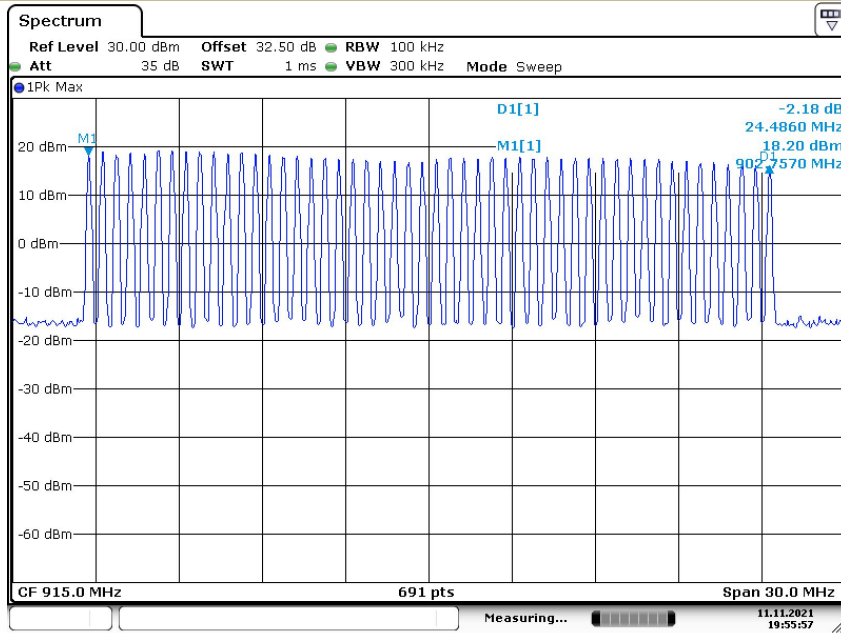

Date: 11.NOV.2021 19:55:57



## 8.4 AVERAGE TIME OF OCCUPANCY (DWELL TIME)

### 8.4.1 Applicable Standard

According to FCC Part 15.247(a)(1)(i) and KDB 558074: D01 15.247 Meas Guidance v05r02

### 8.4.2 Conformance Limit

For frequency hopping systems operating in the 902-928 MHz band: if the 20 dB bandwidth of the hopping channel is less than 250 kHz, the system shall use at least 50 hopping frequencies and the average time of occupancy on any frequency shall not be greater than 0.4 seconds within a 20 second period; if the 20 dB bandwidth of the hopping channel is 250 kHz or greater, the system shall use at least 25 hopping frequencies and the average time of occupancy on any frequency shall not be greater than 0.4 seconds within a 10 second period. The maximum allowed 20 dB bandwidth of the hopping channel is 500 kHz..

### 8.4.3 Test Configuration

Test according to clause 7.1 radio frequency test setup 1

### 8.4.4 Test Procedure

■ According to FCC Part 15.247(a)(1)(iii)

The EUT must have its hopping function enabled. Use the following spectrum analyzer settings:

Span = zero span, centered on a hopping channel

RBW = 100 KHz

VBW ≥ RBW

Sweep = as necessary to capture the entire dwell time per hopping channel

Detector function = peak

Trace = max hold

If possible, use the marker-delta function to determine the dwell time. If this value varies with different modes of operation (e.g., data rate, modulation format, etc.), repeat this test for each variation. The limit is specified in one of the subparagraphs of this Section.

### 8.4.5 Test Results

**PASS.**

All modes (low, mid, high channels) were tested, the data of the worst mode are described in the following pages.

Temperature:	26° C
Relative Humidity:	54%
ATM Pressure:	1011 mbar

Modulation Mode	Frequency (MHz)	occupied time for each channel	dwell time (ms)	Limit(ms)	Verdict
PR-ASK, DSB-ASK	902.75	20.317 ms	203.17 ms	<400	PASS

Note:

occupied time for each channel

20.317ms

Dwell time per 20 seconds

20.317\*10=203.17 ms

Test Model      Average Time Of Occupancy (Dwell Time)  
 RFID  
 CH 01: 902.75MHz      The number of occupied channels per 2 seconds

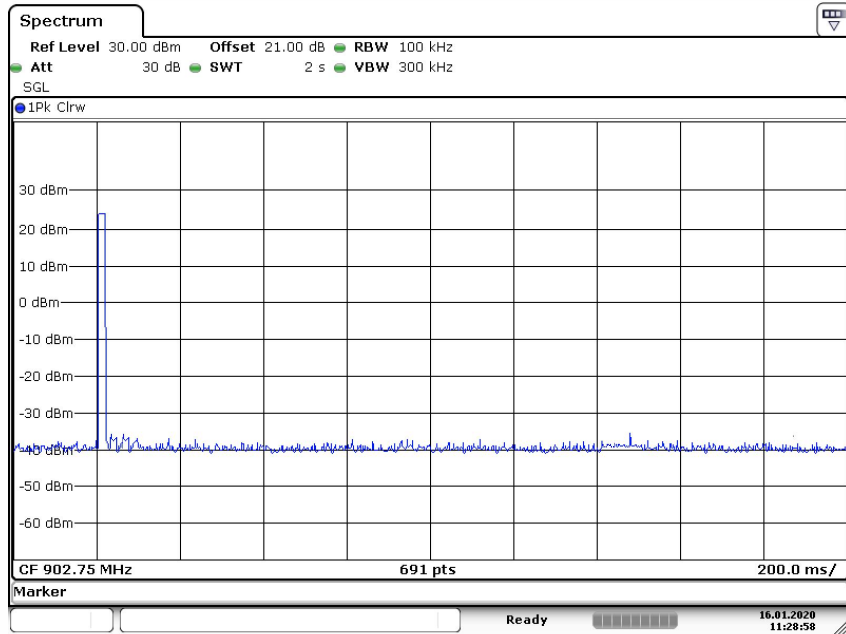

Date: 11.NOV.2021 20:14:53

Test Model      Average Time Of Occupancy (Dwell Time)  
 RFID  
 CH 01: 902.75MHz      occupied time for each channel

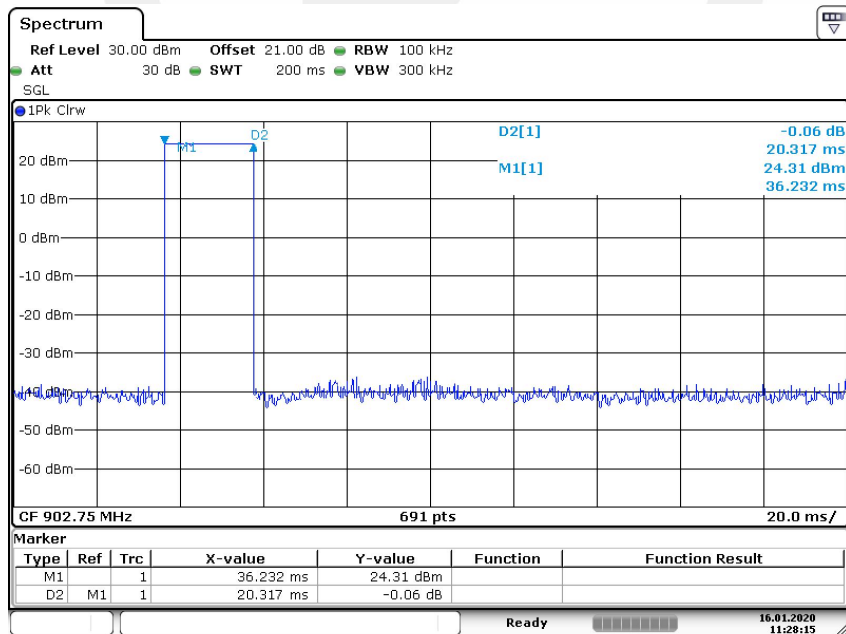

Date: 11.NOV.2021 20:12:30

## 8.5 MAXIMUM PEAK CONDUCTED OUTPUT POWER

### 8.5.1 Applicable Standard

According to FCC Part 15.247(b)(1) and KDB 558074: D01 15.247 Meas Guidance v05r02

### 8.5.2 Conformance Limit

For frequency hopping systems operating in the 902-928 MHz band: 1 watt for systems employing at least 50 hopping channels; and, 0.25 watts for systems employing less than 50 hopping channels, but at least 25 hopping channels, as permitted under paragraph (a)(1)(i) of this section.

### 8.5.3 Test Configuration

Test according to clause 7.1 radio frequency test setup 1

### 8.5.4 Test Procedure

■ According to FCC Part 15.247(b)(1)

As an alternative to a peak power measurement, compliance with the limit can be based on a measurement of the maximum conducted output power.

Use the following spectrum analyzer settings:

Set Span = approximately 5 times the 20 dB bandwidth, centered on a hopping channel (about 10MHz)

Set RBW > the 20 dB bandwidth of the emission being measured (about 1MHz)

Set VBW ≥ RBW

Set Sweep = auto

Set Detector function = peak

Set Trace = max hold

Allow the trace to stabilize. Use the marker-to-peak function to set the marker to the peak of the emission to determine the peak amplitude level.

### Test Results

Temperature:	26° C
Relative Humidity:	54%
ATM Pressure:	1011 mbar

Operation Mode	Channel Number	Channel Frequency (MHz)	Measurement Level (dBm)	Limit (dBm)	Verdict
ASK	01	902.75	<b>17.47</b>	27	PASS
	26	915.25	17.30	27	PASS
	50	927.25	15.61	27	PASS
Note: N/A					



**Test Model** Maximum Peak Conducted Output Power  
RFID  
Channel 01: 902.75MHz

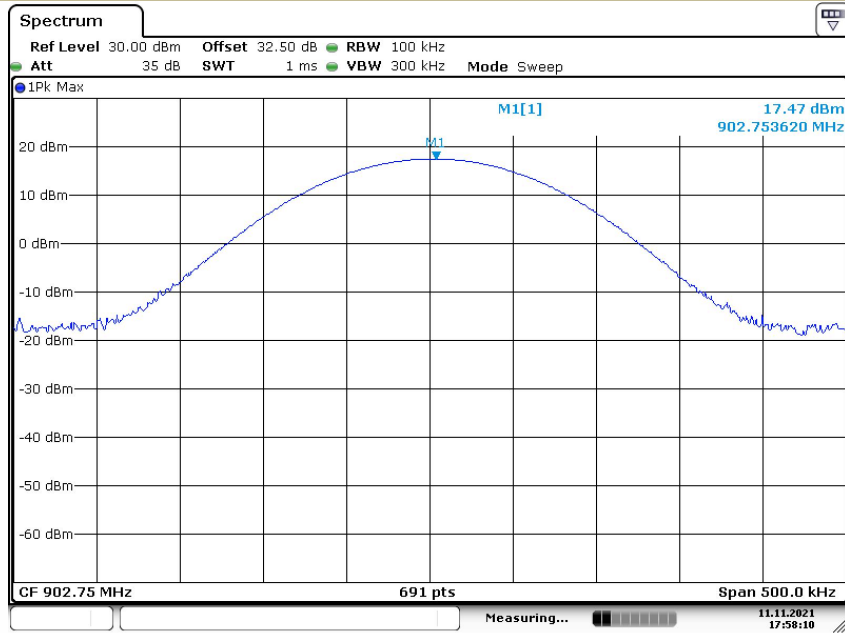

Date: 11.NOV.2021 17:58:10

**Test Model** Maximum Peak Conducted Output Power  
RFID  
Channel 26: 915.25MHz

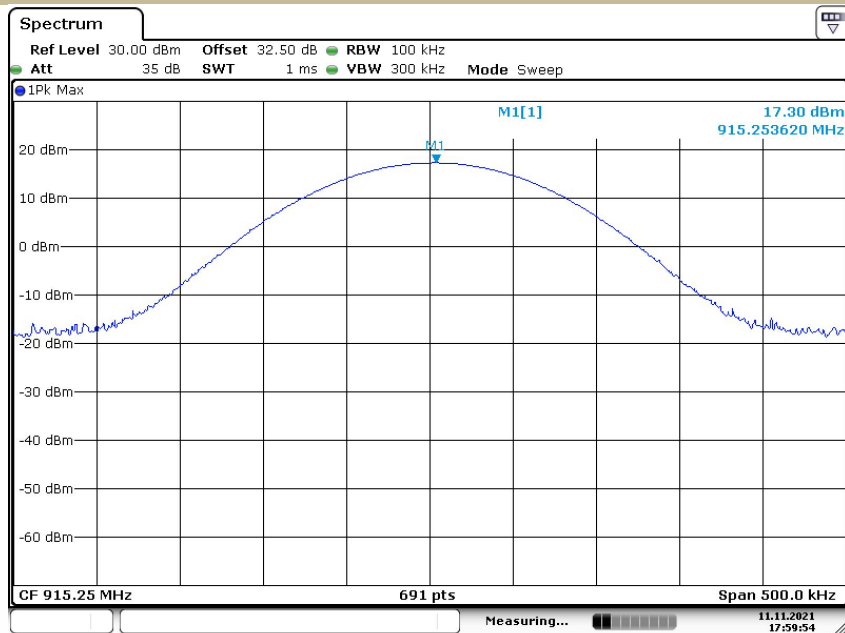

Date: 11.NOV.2021 17:59:55

**Test Model** Maximum Peak Conducted Output Power  
RFID  
Channel 50: 927.25MHz

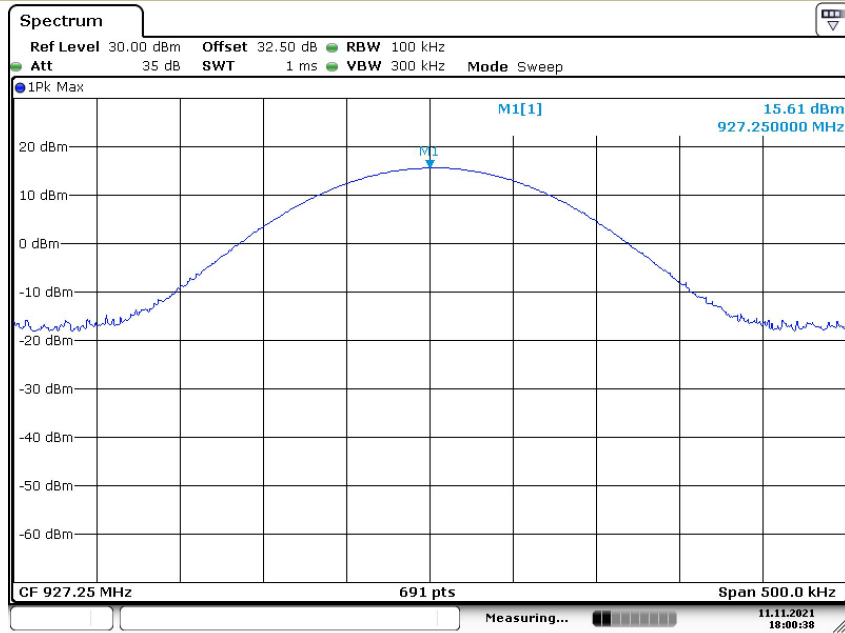

Date: 11.NOV.2021 18:00:38



## 8.6 CONDUCTED SUPRIIOUS EMISSION

### 8.6.1 Applicable Standard

According to FCC Part 15.247(d) and KDB 558074: D01 15.247 Meas Guidance v05r02

### 8.6.2 Conformance Limit

According to FCC Part 15.247(d):

In any 100 kHz bandwidth outside the frequency band in which the spread spectrum intentional radiator is operating, the radio frequency power that is produced by the intentional radiator shall be at least 20 dB below that in the 100 kHz bandwidth within the band that contains the highest level of the desired power, based on either an RF conducted, provided the transmitter demonstrates compliance with the peak conducted power limits.

### 8.6.3 Test Configuration

Test according to clause 7.1 radio frequency test setup 1

### 8.6.4 Test Procedure

The transmitter output (antenna port) was connected to the spectrum analyzer

#### ■ Reference level measurement

Establish a reference level by using the following procedure:

Set instrument center frequency to DSS channel center frequency.

Set Span = approximately 5 times the 20 dB bandwidth, centered on a hopping channel.

Set the RBW = 100 kHz. Set the VBW  $\geq 3 \times$  RBW.

Set Detector = peak. Set Sweep time = auto couple.

Set Trace mode = max hold. Allow trace to fully stabilize.

Use the peak marker function to determine the maximum Maximum conduceted level.

Note that the channel found to contain the maximum conduceted level can be used to establish the reference level.

#### ■ Band-edge Compliance of RF Conducted Emissions

Use the following spectrum analyzer settings:

Span = wide enough to capture the peak level of the emission operating on the channel closest to the band-edge, as well as any modulation products which fall outside of the authorized band of operation

Set RBW  $\geq 1\%$  of the span=100kHz Set VBW  $\geq$  RBW

Set Sweep = auto Set Detector function = peak Set Trace = max hold

Allow the trace to stabilize. Set the marker on the emission at the bandedge, or on the highest modulation product outside of the band, if this level is greater than that at the bandedge. Enable the marker-delta function, then use the marker-to-peak function to move the marker to the peak of the in-band emission. The marker-delta value now displayed must comply with the limit specified in this Section.

Now, using the same instrument settings, enable the hopping function of the EUT. Allow the trace to stabilize.

Follow the same procedure listed above to determine if any spurious emissions caused by the hopping function also comply with the specified limit.

#### ■ Conduceted Spurious RF Conducted Emission

Use the following spectrum analyzer settings:

Span = wide enough to capture the peak level of the in-band emission and all spurious emissions (e.g., harmonics) from the lowest frequency generated in the EUT up through the 10th harmonic.(30MHz to 25GHz). Set RBW = 100 kHz Set VBW  $\geq$  RBW

Set Sweep = auto Set Detector function = peak Set Trace = max hold

Allow the trace to stabilize. Set the marker on the peak of any spurious emission recorded. The level displayed must comply with the limit specified in this Section.

### 8.6.5 Test Results

**Test Model** Maximum Conducted Level RBW=100kHz  
RFID  
Channel 01: 902.75MHz

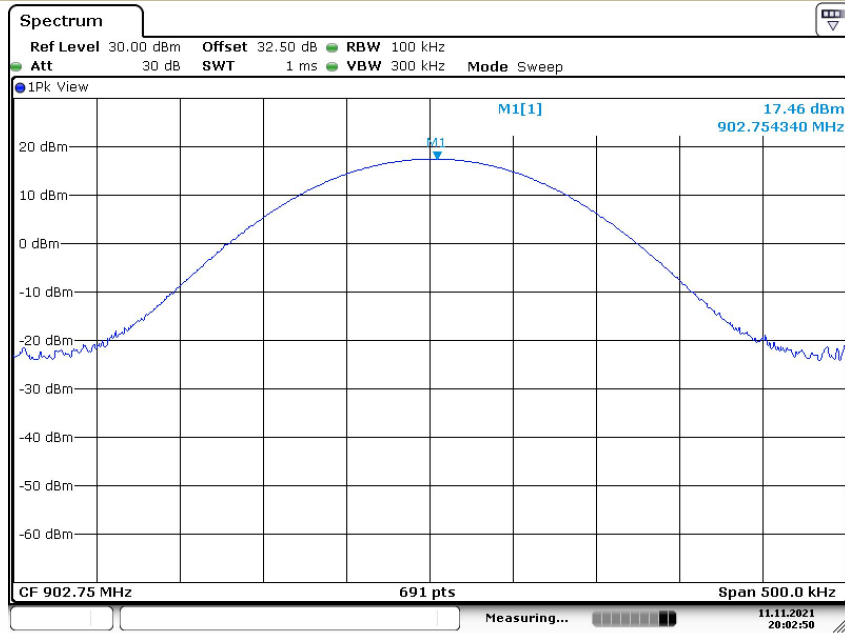

Date: 11.NOV.2021 20:02:50

**Test Model** Conducted Spurious RF Conducted Emission  
RFID  
Channel 01: 902.75MHz

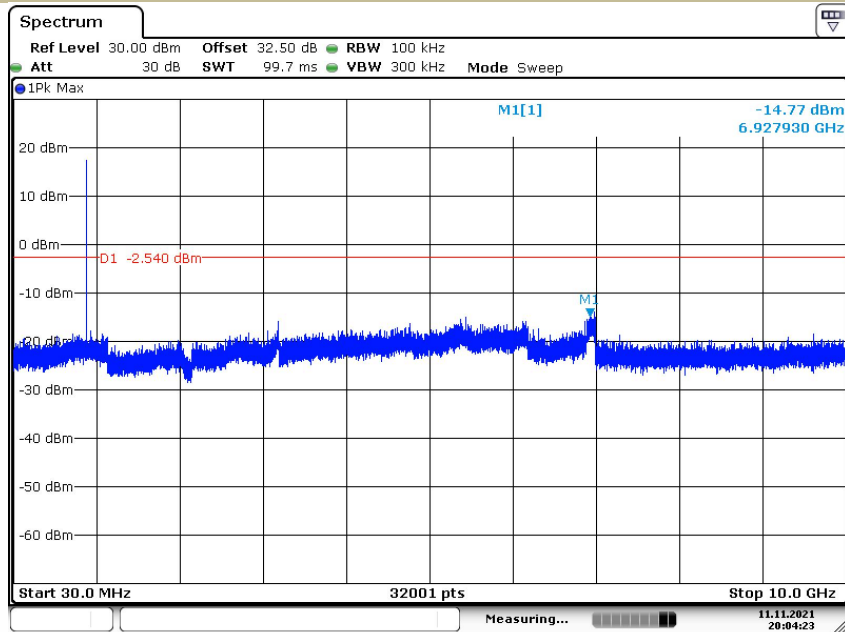

Date: 11.NOV.2021 20:04:23

**Test Model** Band-edge Conducted Emissions  
RFID  
Channel 01: 902.75MHz

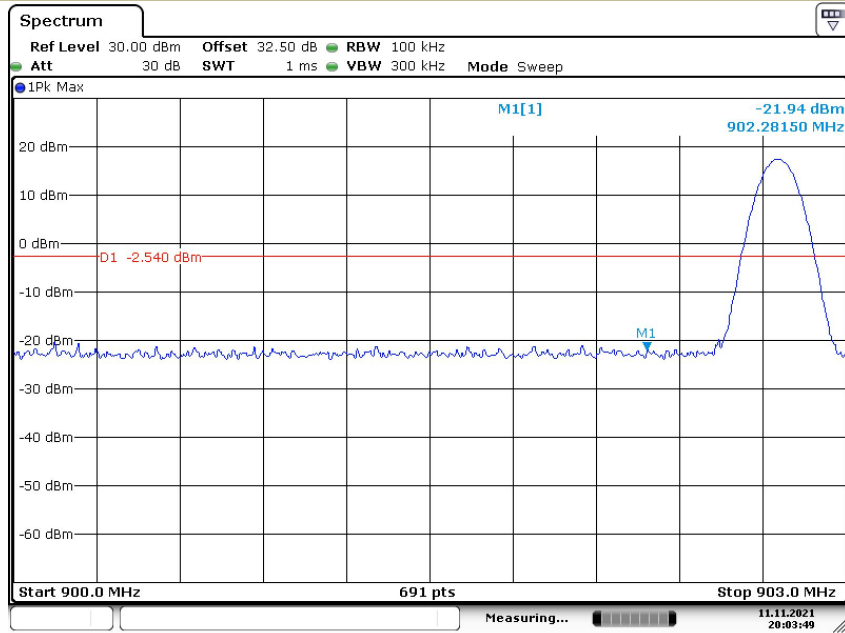

Date: 11.NOV.2021 20:03:48

**Test Model** Maximum Conducted Level RBW=100kHz  
RFID  
Channel 26: 915.25MHz

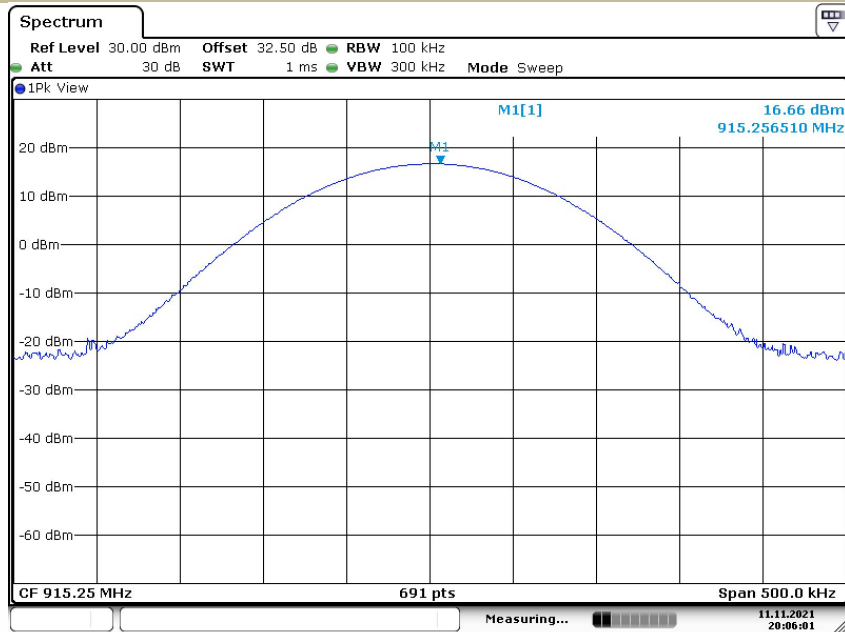

Date: 11.NOV.2021 20:06:01

**Test Model**      **Conduceted Spurious RF Conducted Emission**  
**RFID**  
**Channel 26: 915.25MHz**

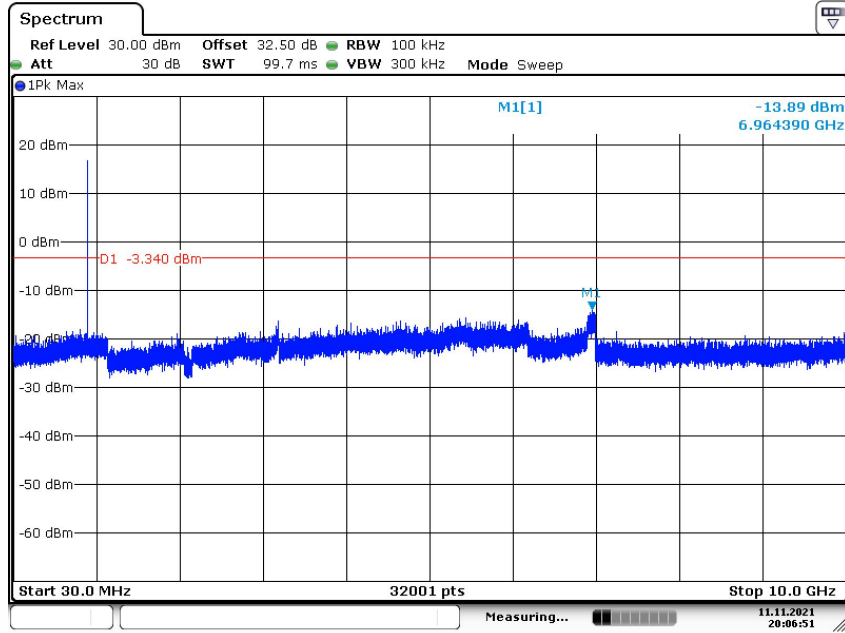

Date: 11.NOV.2021 20:06:51

**Test Model**      **Maximum Conduceted Level RBW=100kHz**  
**RFID**  
**Channel 50: 927.25MHz**

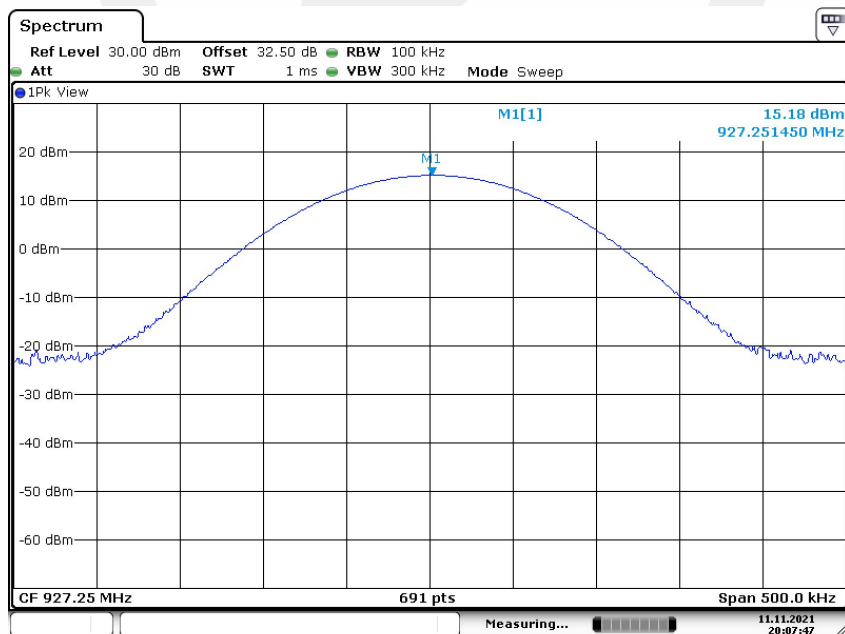

Date: 11.NOV.2021 20:07:47

**Test Model**      **Conducted Spurious RF Conducted Emission**  
**RFID**  
**Channel 50: 927.25MHz**

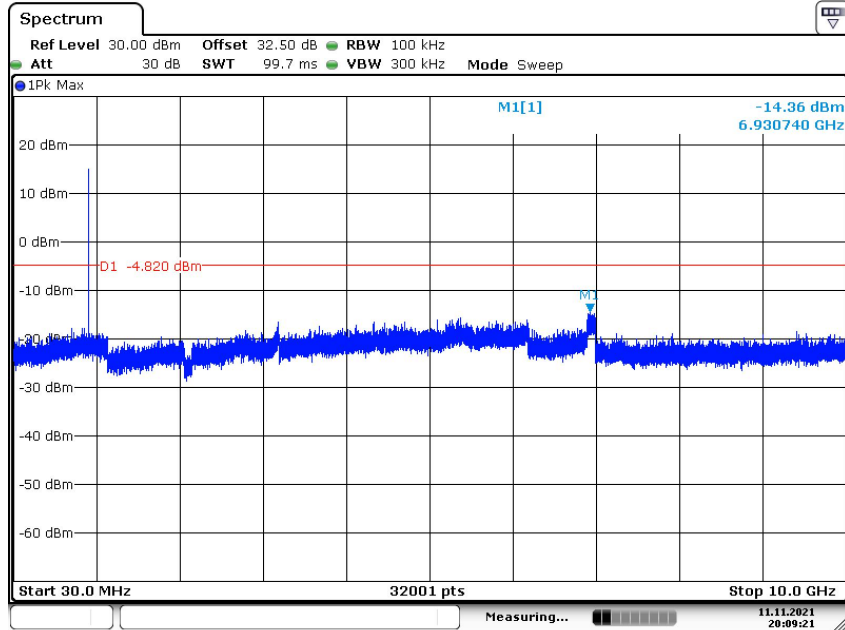

Date: 11.NOV.2021 20:09:21

**Test Model**      **Band-edge Conducted Emissions**  
**RFID**  
**Channel 50: 927.25MHz**

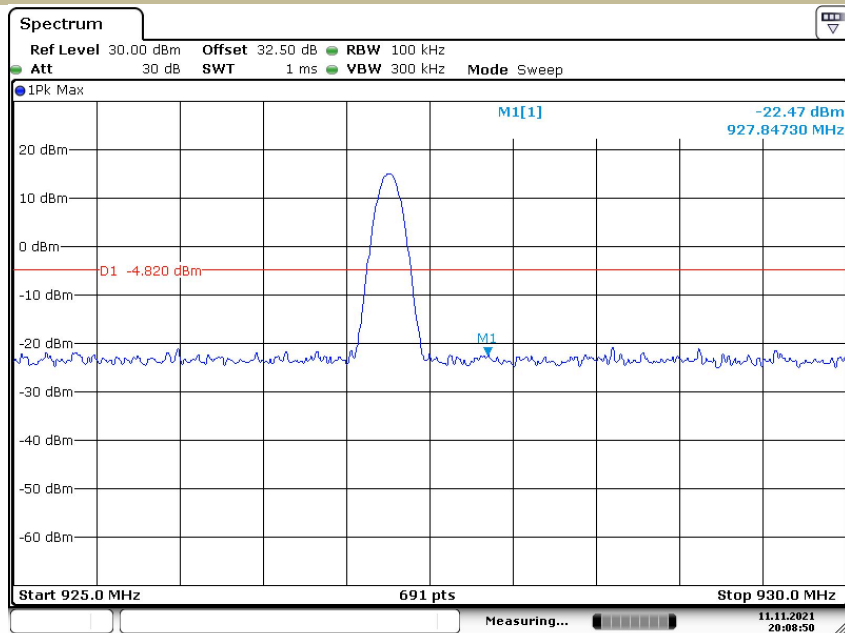

Date: 11.NOV.2021 20:08:50

**Test Model** Maximum Conducted Level RBW=100kHz  
RFID  
Hopping

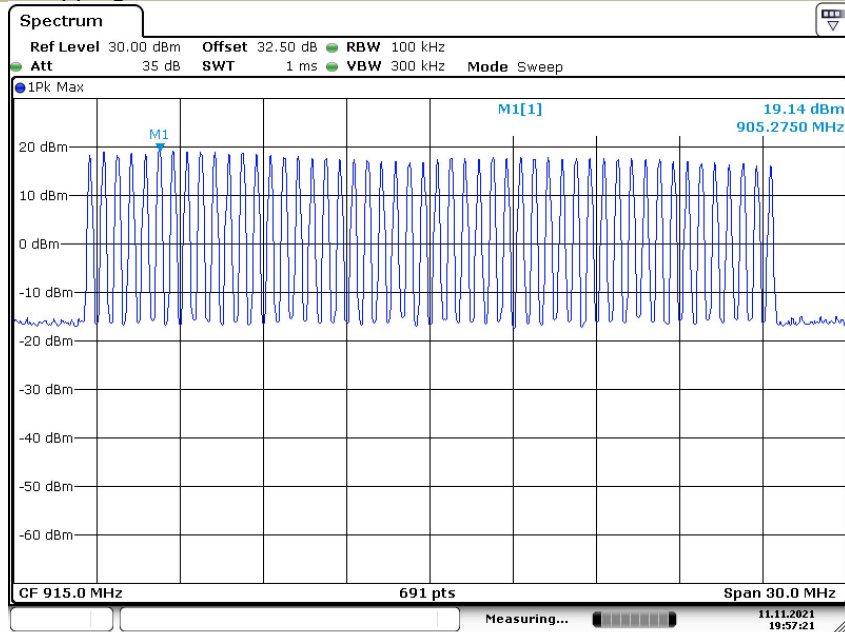

Date: 11.NOV.2021 19:57:22

**Test Model** Conducted Spurious RF Conducted Emission  
RFID  
Hopping

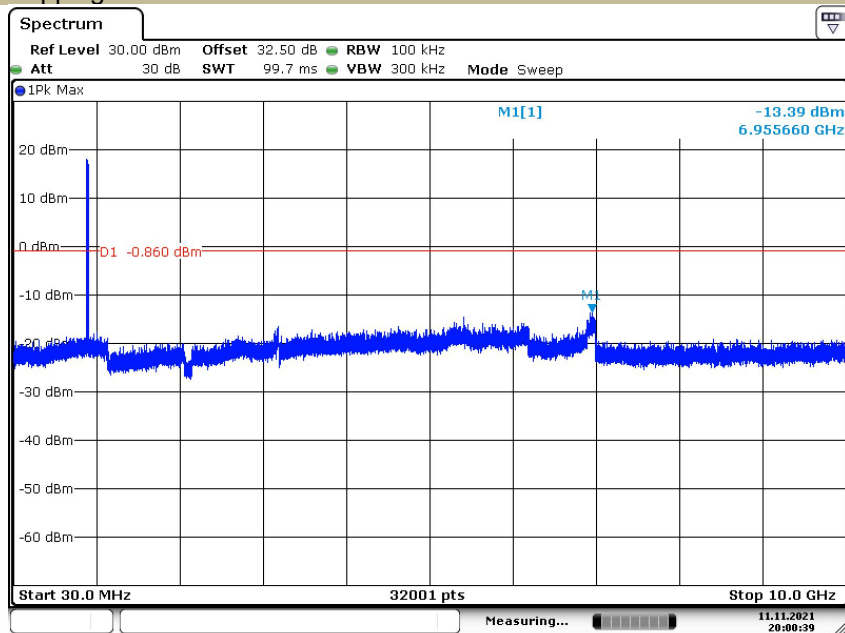

Date: 11.NOV.2021 20:00:39