

**SPECIFICATION FOR APPROVAL**

CUSTOMER: **SZ003**

---

CUST P/N: **1031.00331**

---

FINE P/N: **FYS003078**

---

DESC: **FYSZ00312023051501**

---

DATE: **2023/06/30**

---

Version: **A.1**

---

PREPARED BY	CHECKED BY	APPROVED BY	CUSTOMER APPROVE
Huang Xiaoyuan	Cai Jiyu	Ding Baoyuan	

**FINE ELECTRONICS INDUSTRIAL (HK) LIMITED**

Factory address: Sijia Industrial Zone,  
Shijie Town, Dongguan City

TEL: 0769-22490287 / 22452492 FAX:

0769-22499451

E-mail: fineelec@163.com



# SPECIFICATION

DESC	<b>FYSZ00312023051501</b>	Rev: A.1	CUST:	<b>SZ003</b>
			Fine P/N:	<b>FYS003078</b>
			CUST P/N:	<b>1031.00331</b>

一、 DIMENSION:(mm)

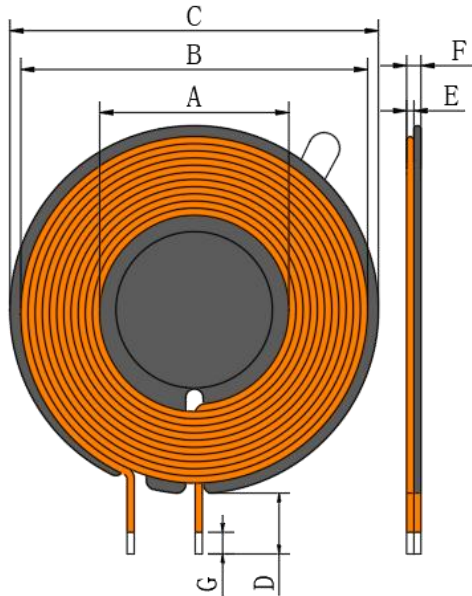

A	21.46±0.5
B	39.3±0.5
C	42.4±0.2
D	5.52±1.5
E	0.8±0.2
F	2.05-2.2 (不含离型纸厚度)
G	2.5Max(不带黄胶)

Note:

1. The leads do not cross and do not need to be bent; 2. The coil is equipped with a reverse magnetic disc, with a size of 42.4 \* 1.0mm, double straight slots, and a diameter of 18mm \* 0.75 in the middle. The small magnetic disc is attached on one side with a diameter of 15 \* 0.08 ordinary back glue with hand tear position;
3. Stick one side of the magnetic disc with a diameter of 41.2 \* 0.15, open double groove 3M9448A, and tear off the double-sided backing tape by hand

二、 SCHEMATIC DIAGRAM:

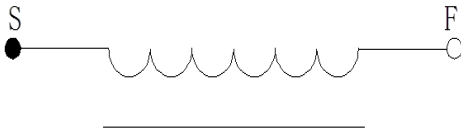

三、 Winding Specification:

NO.	TERMINAL	WIRE	Turns	Winding Direction
1	S F	Litz0.08*65p	11Ts	CW

四、 ELECTRICAL CHARACTERISTICS:

TEMPERATURE:25±10°C, RELATIVE HUMIDITY:65±20%

NO.	ITEM	TERMINAL	SPECIFICATION	TEST FREQUENCY	TEST EQUIPMENTS
1	IND.	S-F	8.4uH ±5%	360KHz/1.0V	TH2810
2	DCR	S-F	≤70mΩ	360KHz/1.0V	TH2810

PREPARED BY/DATE	CHECKED BY/DATE
Huang Xiaoyuan 2023/06/30	Cai Jiayu 2023/06/30

## SPECIFICATION

DESC	<b>FYSZ00312023051501</b>	Rev: A.1	CUST:	<b>SZ003</b>
			Fine P/N:	<b>FYS003078</b>
			CUST P/N:	<b>1031.00331</b>

五、PACKONG:

5.1 Packing pictures:

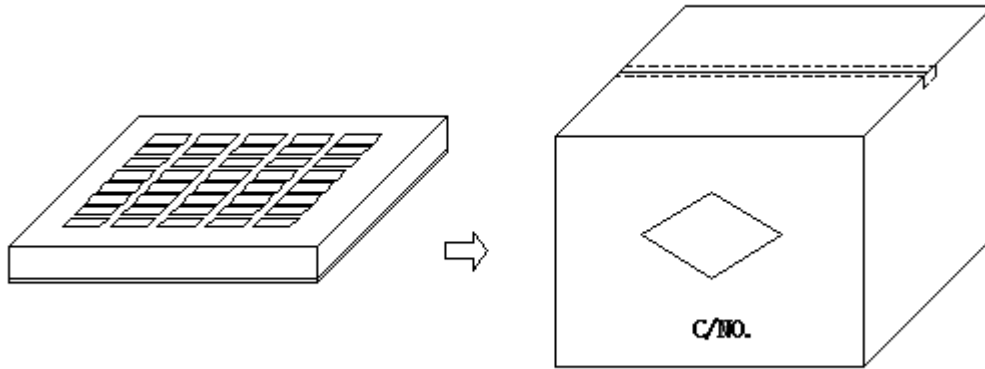

5.2 Packing Quantity:

Item	Quantity	Material
Box	200 Pcs	370*265*55mm
Big Carton	1000 Pcs	420*270*310mm

5.3

The packaging shall be based on the existing packing plate and the actual delivery package shall prevail. If there is any requirement, we can customize it.

六、Material list:

number	Material name	Description	Manufacturer
1	Litz0.08*65p	Litz0.08*65p	
2	Solder Bar	Solder Bar	Yuexing
3	Magnetic disc	Magnetic disk size of 42.4 * 1.0mm, with double straight slots	
4	Small magnetic disc	φ 18mm*0.75	
5	3M9448A adhesive backing	φ41.2*0.15 Open double groove 3M9448A with manual tearing position double-sided adhesive backing	
6	Ordinary backing adhesive	φ15*0.08 Ordinary back adhesive with hand tear position	

<b>PREPARED BY/DATE</b>	<b>CHECKED BY/DATE</b>
Huang Xiaoyuan 2023/06/30	Cai Jiyu 2023/06/30