

NEXTECH



1080p WiFi IP Camera Y6

Before using this product, please read the guide carefully to avoid any damages to the product, do not misconfiguration or misuse.

Distributed by: TechBrands by Electus Distribution Pty. Ltd.

320 Victoria Rd, Rydalmere, NSW 2116 Australia

Ph: 1300 738 555

Int'l: +61 2 8832 3200

Fax: 1300 738 500

www.techbrands.com

Made in China

1. Product Description

1.1 Packing list

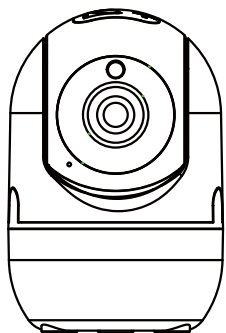

Camera



Adapter



USB cable



User manual

*Pictures are only for reference.

1.2 Product outlook

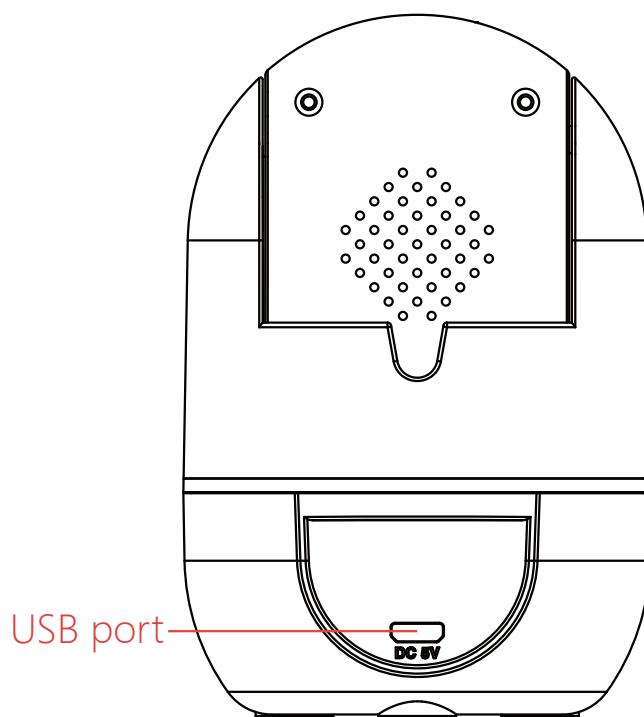
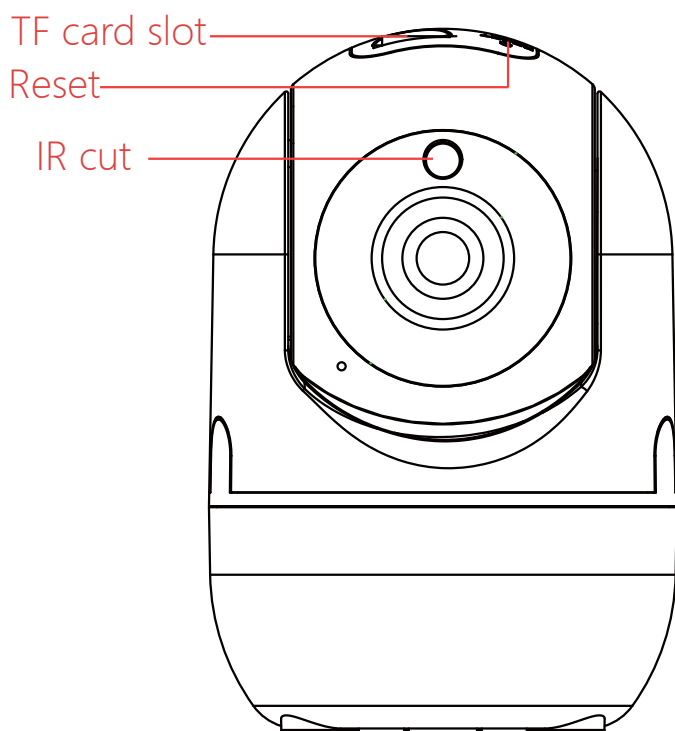

2. Installation

2.1 App installation

For iPhone users:

Open the App Store and search for “Nextech Smart Cam”
Download and install the Linked app onto your iPhone.

For Android phone users:

Open the Google Play Store and search for “Nextech Smart Cam”
Download and install the Linked app onto your Android phone.



Nextech SmartCam

2.2 Device Hardware installation

Connect the power supply to the camera device, then wait for the indicator light to flash.

Different LED colors correspond to different camera status:

Blue	System start up
Slow blue flash	Syncing mode
Fast blue flash	Connecting to Wi-Fi
Solid blue	Camera working properly

2.3 User Account Registration

1. After opening the app for the first time, register your account by clicking 'sign up' and enter the email address.
 - a. Click "Send code", your email will receive a verification code, enter the code within 30 minutes.
 - b. Input the password twice, click "Register immediately".
 - c. Your login information will be saved the next time you open the app; however, it is recommended that you write your login information down.

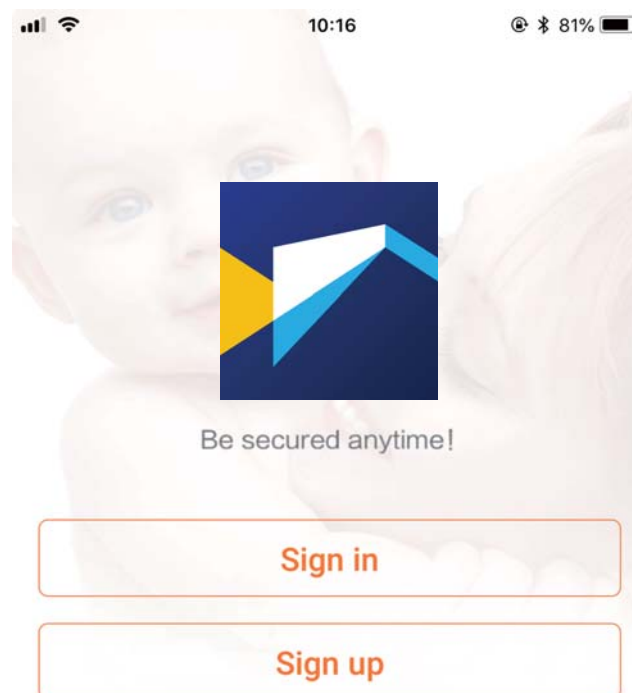

2.4 Camera Device and Phone Synchronization

Click Add Camera button, click on 'connecting my camera'

Step 1: Check to see if the front LED light is flashing: After powering on the camera, the LED light should be flashing blue, click on 'Next' and proceed to Step 2.

Step 2: Connect to your wifi network(802.11 b/g/n 2.4GHz):

a. Find your wireless network in the first field. You can select 'Other' if you do not see your wireless network.

b. Enter your Wi-Fi password. If your wireless network does not have a password, click on the 'No Wi-Fi password' box. Then click 'Next', select your timezone.

c. Follow the instructions on the screen and move your phone speaker close to the camera's microphone. Before doing so, make sure you are in a quiet environment without any noise interference and make sure your phone is not on silent. Then click 'send sound wave'.

d. You will hear a scrambled sound being played from your phone. Keep your phone still and wait for the duration of the transmission, before you move your phone away. Afterwards, the voice prompt will indicate that the binding was successful and the app will redirect to the camera view interface automatically.

e. If you do not hear the voice prompt say, 'binding successful', you can try again by clicking the 'Send sound wave.'

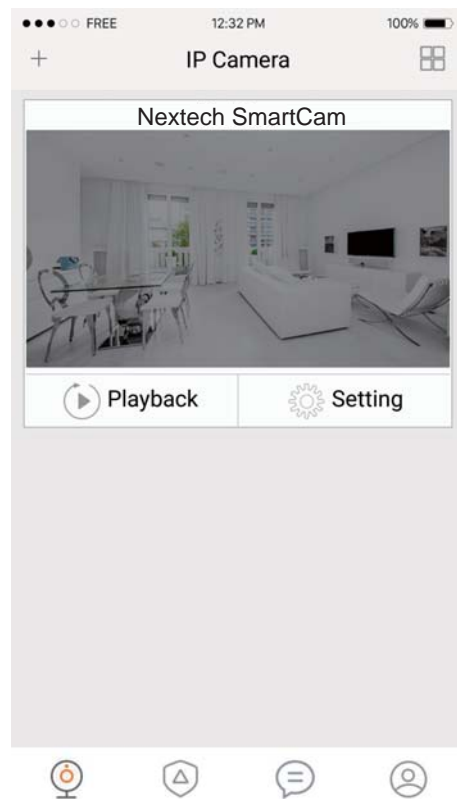
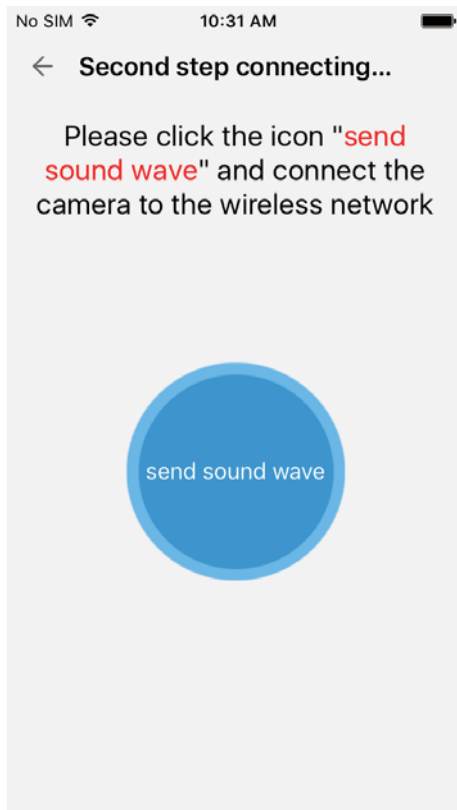

3. App functions

3.1 Live video

After syncing successfully, click the IP Camera interface to view live video. Smooth, SD and HD video definition are available.

3.2 Video Recording

3.2.1 Users can record video on live video interface , by pressing the red video recording icon on the left, refer to photo below.

The recorded video will be stored in the album on the homepage of app.

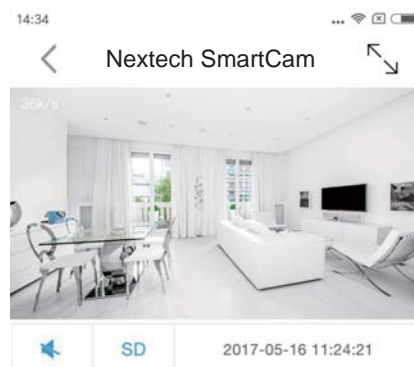

3.2.2 Playback: Click “Playback” icon and choose the time to replay the video recorded in the MicroSD card.

Select the date and time you wish to playback. You can fast forward/backward by swiping on the time bar. Tap on the camera icon to take a screen shot while replaying the video.

Refer to photo below.



Select time



3.3 SNAPSHOT SHARING

Our camera provides a function that shares any snapshot photos to Email/SMS, etc. To access snapshots, please follow same directions as accessing your video recording explained under playback feature, choose the photo you want to share and the platform you want to share it from as indicated in Figure 1.



Figure 1

3.4 SUB-ACCOUNT MANAGEMENT

Sub-Accounts gives you the option to allow for multiple users live access to the same camera. Each camera can support up to 15 live viewer accounts (including the Administrator account). The administrator can add and delete sub-accounts by using Sub-Account Management function. Refer Figures 2, 3 & 4 below.

New sub-accounts can be setup by clicking on the “Add” button. Note: Please follow the same procedure under user account registration in page 2 to register and verify the email address you are willing to add as a sub-account prior to adding it as new sub-account.

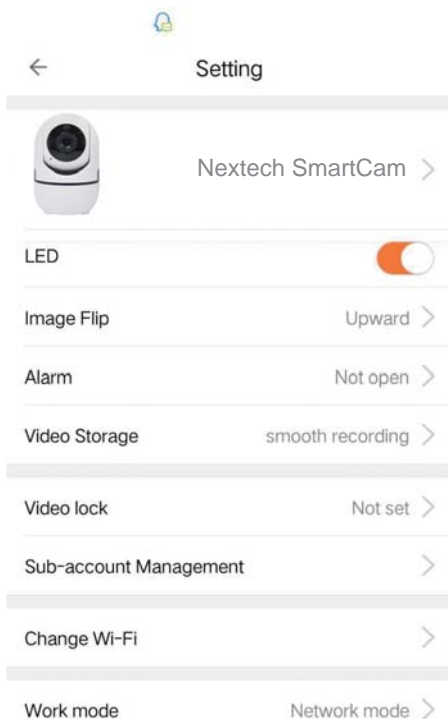

Figure 2

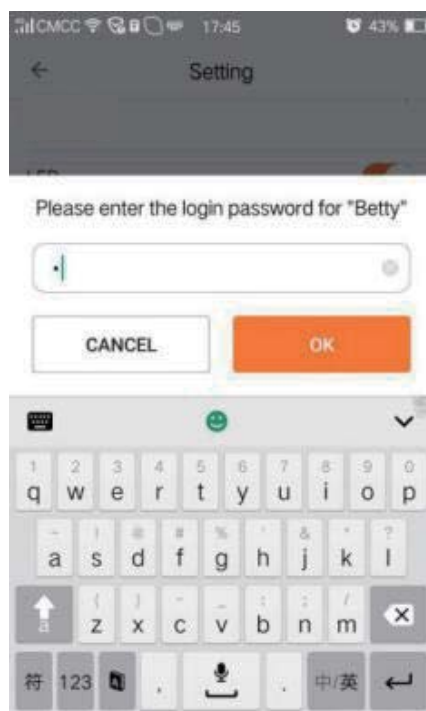

Figure 3

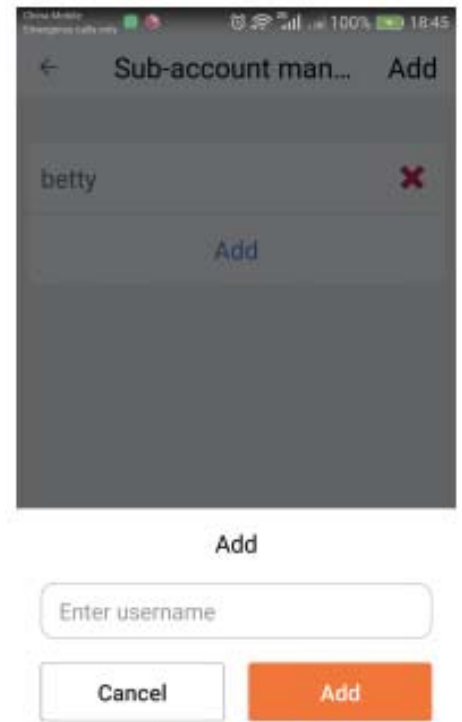

Figure 4

3.5 VIEWING LOCK

This function allows the user to watch live video and replay videos only after a password has been setup.

- 1) To set up, click on the ‘Setting’ button in the IP camera page as indicated in Figure 5 & 6 below.
- 2) In the Setting screen, tap on the ‘Video Lock’ button [defaulted to ‘Not Set’] as indicated in Figure 7 below.
- 3) Then enter a password that you can remember.

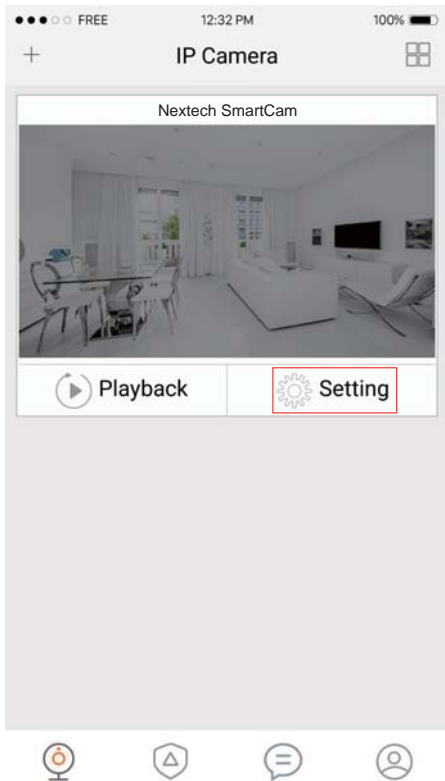

Figure 5

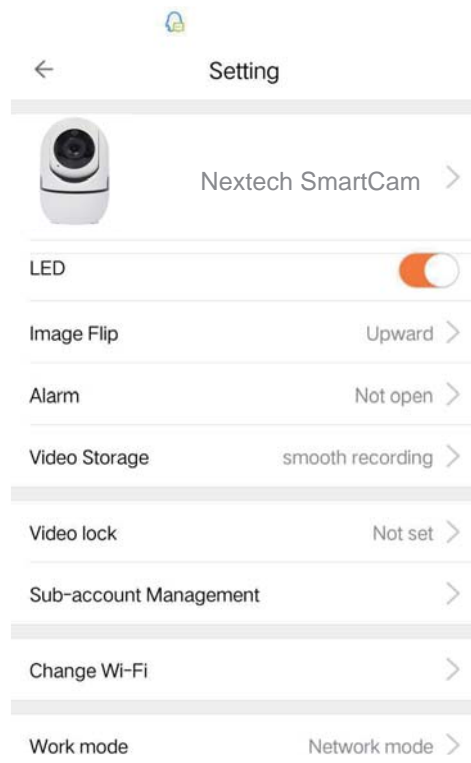

Figure 6

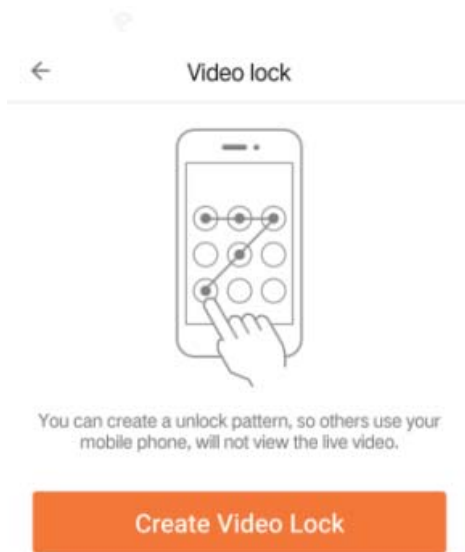

Figure 7



Figure 8

3.6 TWO WAY AUDIO

When you are viewing camera, you can press the “Microphone Icon” as indicated in Figure 8 above and talk or if the volume on the phone is up the voice from the camera could be heard in the phone.

3.7 INFRARED NIGHT VISION

Infrared night vision is controlled by camera system automatically. When the area around the camera becomes too dark, the infrared night vision will activate automatically. Likewise, when the area around the camera is bright enough, the night vision will deactivate automatically.

3.8 INFRARED ALARM

The camera uses infrared sensors when someone/something appears within its detection area. The alarm on camera will ring for 5 seconds, and at the same time, the phone will also ring and receive an alarm notification. Set the alert notification message to access the live video feed.

You can adjust the timing of the alarm and enable/disable the alarm sound under the camera setting.

3.9 REMOTE CONTROL YOUR Y6 BY APP

Enter the live video interface of the Nextech Smartcam Camera APP, using the direction arrows on the screen: up/down/left/right to control the camera to rotate vertically/horizontally.



4. Warning

- When using the camera, please avoid rain, fire and lightning. The camera's working humidity range is: 20%-50% indoor, 20%-70% outdoor. Working temperature range is: -10°-50°C (14°-122°F) indoor; -20°-55°C (-4°-131°F) outdoor.
- The IP Camera is designed to ensure the security and confidentiality of its users, but cannot completely guarantee the threat of being compromised, due to various setup circumstances. We highly advise that you only use the camera on a trusted password protected Wi-Fi network. This camera is recommended for general purpose monitoring only. The user acknowledges the risk of using the device otherwise.

5 . FAQ

1) Cannot bind camera device?

- ☆ User can only bind when the camera device is in the Binding mode (i.e. LED is blue and flashes once a second). Otherwise, you cannot bind a camera device when outside of the Binding mode.
- ☆ Make sure the environment around the camera is quiet when transmitting the "sound wave" and the outer speaker of your phone is close to the microphone in the side of the camera.
- ☆ If shown warning "WIFI does not exists" , please make sure your Wi-Fi network name is correct.
- ☆ If shown warning "WIFI connection fail" , please make sure your Wi-Fi password is correct.
- ☆ If shown warning "Network abnormal please check router configuration" , please make sure your router is connected to Internet.

2) Cannot connect to Internet?

- ☆ Check the compatibility of the camera device with your router. Supports 802.11 b/g/n 2.4GHz wifi network.
- ☆ Check whether the name and password of WIFI has been changed.

3) Video quality is not clear?

Switch between "SD" and "HD" .

4) Cannot replay video?

☆ Check if there is a micro-SD card.

☆ Insert a micro-SD card, you can replay video after 10 minutes.

5) If the Wi-Fi is hidden, why cannot I find any network or camera device?

Our camera device can only connect to non-hidden Wi-Fi networks.

6) How to restore Factory Settings?

While the camera device is on, use a small object to hold down the reset button located on the back of the unit for 3-5 seconds. During the period, do not unplug the camera device.

7) Sound is not coming from app on phone?

Please make sure your phone is not on silent and the volume is turned up.

OTHER NOTES:

- To refresh your camera list, pull-down on the screen while viewing the camera list.
- After binding the device and phone successfully, if the camera device does not appear on the homepage, refresh the camera list interface. If the device is still not showing, log out of your account, then login again.
- There is approximately a 10-minute delay after a micro SD card has been inserted before you can replay videos.
- When testing the alarm function, after setting the alarm, please exit the app to receive the notification when the camera is triggered by motion.
- 15 user accounts can view the live video of the camera simultaneously (if the account administrator shares access).
- The first account bound to the camera is defaulted as the administrator account.
- When syncing the camera device and phone, do not leave the binding page, please wait for the camera to finish automatically.

FCC WARNING STATEMENT

Changes or modifications not expressly approved by the party responsible for compliance could void the user's authority to operate the equipment. This equipment has been tested and found to comply with the limits for a Class B digital device, pursuant to Part 15 of the FCC Rules. These limits are designed to provide reasonable protection against harmful interference in a residential installation. This equipment generates uses and can radiate radio frequency energy and, if not installed and used in accordance with the instructions, may cause harmful interference to radio communications. However, there is no guarantee that interference will not occur in a particular installation. If this equipment does cause harmful interference to radio or television reception, which can be determined by turning the equipment off and on, the user is encouraged to try to correct the interference by one or more of the following measures:

- - Reorient or relocate the receiving antenna.
- - Increase the separation between the equipment and receiver.

- - Connect the equipment into an outlet on a circuit different from that to which the receiver is connected.

- - Consult the dealer or an experienced radio/TV technician for help.

This equipment should be installed and operated with minimum distance 20cm between the radiator and your body.