



FCC TEST REPORT
FCC ID: 2AN9Q-THIAMISX
On Behalf of
Netronix Group.INC
Thiamis Embedded Platform
Model No.: Thiamis X module

Prepared for : Netronix Group.INC
Address : 3401 Greys Ferry Avenue Philadelphia,PA 19146

Prepared By : Shenzhen Alpha Product Testing Co., Ltd.
Address : Building i, No.2, Lixin Road, Fuyong Street, Bao'an District, 518103,
Shenzhen, Guangdong, China

Report Number : T1871822 08
Date of Receipt : October 16, 2017
Date of Test : May 08, 2018- July 02, 2018
Date of Report : July 02, 2018
Version Number : REV0

TABLE OF CONTENTS

Description	Page
1. Summary of Standards And Results -----	6
1.1. Description of Standards and Results -----	6
2. General Information -----	7
2.1. Description of Device (EUT)-----	7
2.2. Accessories of Device (EUT) -----	8
2.3. Tested Supporting System Details-----	8
2.4. Block Diagram of connection between EUT and simulators-----	8
2.5. Test Mode Description-----	8
2.6. Test Conditions-----	8
2.7. Test Facility -----	9
2.8. Measurement Uncertainty-----	9
2.9. Test Equipment List -----	10
3. Spurious Emission -----	11
3.1. Test Limits -----	11
3.2. Test Procedure-----	11
3.3. Test Setup -----	12
3.4. Test Results -----	13
4. Power Line Conducted Emission -----	17
4.1. Test Limits -----	17
4.2. Test Procedure-----	17
4.3. Test Setup -----	17
4.4. Test Results -----	18
5. Conducted Maximum Output Power -----	20
5.1. Test limits -----	20
5.2. Test Procedure-----	20
5.3. Test Setup -----	20
5.4. Test Results -----	20
6. Peak Power Spectral Density -----	21
6.1. Test limits -----	21
6.2. Test Procedure-----	21
6.3. Test Setup -----	21
6.4. Test Results -----	22
7. Bandwidth -----	24
7.1. Test limits -----	24
7.2. Test Procedure-----	24
7.3. Test Setup -----	24
7.4. Test Results -----	24
8. Band Edge Check -----	27
8.1. Test limits -----	27
8.2. Test Procedure-----	27
8.3. Test Setup -----	27
8.4. Test Results -----	28
9. Antenna Requirement -----	30
9.1. Standard Requirement -----	30
9.2. Antenna Connected Construction-----	30

9.3. Results	30
10. Test setup photo	31
10.1. Photos of Radiated emission.....	31
10.2. Photos of Conducted Emission test	32
11. Test setup photo	33

TEST REPORT DECLARATION

Applicant : Netronix Group.INC
 Address : 3401 Greys Ferry Avenue Philadelphia,PA 19146
 Manufacturer : Netronix Group.INC
 Address : 3401 Greys Ferry Avenue Philadelphia,PA 19146
 EUT Description : Thiamis Embedded Platform
 (A) Model No. : Thiamis X module
 (B) Trademark : N/A

Measurement Standard Used:

**FCC Rules and Regulations Part 15 Subpart C Section 15.247: 2017,
ANSI C63.10-2013**

The device described above is tested by Shenzhen Alpha Product Testing Co., Ltd. to determine the maximum emission levels emanating from the device. The maximum emission levels are compared to the FCC Part 15 Subpart C limits both conducted and radiated emissions. The test results are contained in this test report and Shenzhen Alpha Product Testing Co., Ltd. is assumed of full responsibility for the accuracy and completeness of these tests.

After the test, our opinion is that EUT compliance with the requirement of the above standards.

This report applies to above tested sample only. This report shall not be reproduced in parts without written approval of Shenzhen Alpha Product Testing Co., Ltd.

Tested by (name + signature).....: Reak Yang
 Project Engineer 

Approved by (name + signature).....: Simple Guan
 Project Manager 

Date of issue..... : July 02, 2018

Revision History

Revision	Issue Date	Revisions	Revised By
00	July 02, 2018	Initial released Issue	Simple Guan

1. SUMMARY OF STANDARDS AND RESULTS

1.1. Description of Standards and Results

The EUT have been tested according to the applicable standards as referenced below:

Test Item	Test Requirement	Standards Paragraph	Result
Conducted Emission	FCC PART 15:2017	15.207	P
6dB Bandwidth	FCC PART 15:2017	15.247 (a)(2)	P
Output Power	FCC PART 15:2017	15.247 (b)(3)	P
Radiated Spurious Emission	FCC PART 15:2017	15.247 (c)	P
Conducted Spurious & Band Edge Emission	FCC PART 15:2017	15.247 (d)	P
Power Spectral Density	FCC PART 15:2017	15.247 (e)	P
Radiated Band Edge Emission	FCC PART 15:2017	15.205	P
Antenna Requirement	FCC PART 15:2017	15.203	P
Note:	1. P is an abbreviation for Pass. 2. F is an abbreviation for Fail. 3. N/A is an abbreviation for Not Applicable.		

2. GENERAL INFORMATION

2.1. Description of Device (EUT)

Description	: Thiamis Embedded Platform
Model Number	: Thiamis X module
Diff	: N/A
Trademark	: N/A
Test Voltage	: DC 3.9V from Main Board
Radio Technology	: IEEE 802.15.4 ZigBee
Operation frequency	: 2405-2480MHz
Channel No.	: 16 Channels
Modulation type	: O-QPSK
Antenna Type	: Ceramics Antenna, Maximum Gain is 1.0dBi
Software version	: 0C010101
Hardware version	: 102

2.2. Accessories of Device (EUT)

Accessory 1 : N/A

2.3. Tested Supporting System Details

No.	Description	Manufacturer	Model	Serial Number	Certification or DOC
1	Notebook	ACER	ZQT	N/A	DOC
2.	CC Debugger	TI	CC Debugger	N/A	N/A
3.	Serial board	TI	YP-05	N/A	N/A
4.	Serial board	TI	YP-05	N/A	N/A
5.	Development Board	Netronix	Thiamis X & G Development Board	N/A	N/A
6.	Power Supply	ABT	ABT030120	N/A	N/A

2.4. Block Diagram of connection between EUT and simulators

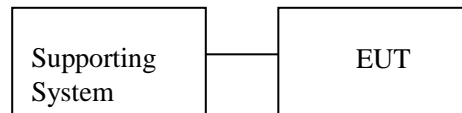

2.5. Test Mode Description

Tested mode, channel, and data rate information		
Mode	Channel	Frequency (MHz)
O-QPSK	Low :CH1	2405
	Middle: CH8	2440
	High: CH16	2480

2.6. Test Conditions

Items	Required	Actual
Temperature range:	15-35°C	27°C
Humidity range:	25-75%	56%
Pressure range:	86-106kPa	980kPa

2.7. Test Facility

Shenzhen Alpha Product Testing Co., Ltd
 Building i, No.2, Lixin Road, Fuyong Street, Bao'an District, 518103,
 Shenzhen, Guangdong, China

June 21, 2018 File on Federal Communication Commission
 Registration Number: 293961

July 25, 2017 Certificated by IC
 Registration Number: 12135A

2.8. Measurement Uncertainty

(95% confidence levels, k=2)

Item	Uncertainty
Uncertainty for Power point Conducted Emissions Test	2.74dB
Uncertainty for Radiation Emission test in 3m chamber (below 30MHz)	2.13 dB(Polarize: V)
	2.57dB(Polarize: H)
Uncertainty for Radiation Emission test in 3m chamber (30MHz to 1GHz)	3.77dB(Polarize: V)
	3.80dB(Polarize: H)
Uncertainty for Radiation Emission test in 3m chamber (1GHz to 25GHz)	4.16dB(Polarize: H)
	4.13dB(Polarize: V)
Uncertainty for radio frequency	5.4×10^{-8}
Uncertainty for conducted RF Power	0.37dB
Uncertainty for temperature	0.2°C
Uncertainty for humidity	1%
Uncertainty for DC and low frequency voltages	0.06%

2.9. Test Equipment List

Equipment	Manufacturer	Model No.	Serial No.	Last cal.	Cal. Due day
Spectrum analyzer	Agilent	E4407B	MY49510055	2017.09.23	2018.09.22
Horn Antenna	SCHWARZBECK	BBHA 9120 D	BBHA 9120 D(1201)	2016.09.30	2018.09.29
Filter	KANGMAI	ZLPF-LDC-1000- 1959	1209002075	2017.09.22	2018.09.21
Filter	WAINWRIGHT	WHKX2.80 /18G- 12SS	SN1	2017.09.22	2018.09.21
RF Cable	Resenberger	Cable 4	N/A	2017.09.22	2018.09.21
Signal Analyzer	Agilent	N9020A	MY499100060	2017.09.23	2018.09.22
Amplifier	HP	HP8347A	2834A00455	2017.09.23	2018.09.22
Amplifier	Agilent	8449B	3008A02664	2017.09.23	2018.09.22
Filter	WAINWRIGHT	WHKX1.0G/15G- 10SS	SN40	2017.09.22	2018.09.21
Test Receiver	ROHDE&SCHWARZ	ESR	1316.3003K03-102082-Wa	2017.09.23	2018.09.22
Bilog Antenna	SCHWARZBECK	VULB 9168	9168-438	2016.09.30	2018.09.29
9*6*6 anechoic chamber	CHENYU	9*6*6	N/A	2016.07.21	2020.07.20
RF Cable	Resenberger	Cable 1	N/A	2017.09.22	2018.09.21
RF Cable	Resenberger	Cable 2	N/A	2017.09.22	2018.09.21
RF Cable	Resenberger	Cable 3	N/A	2017.09.28	2018.09.27
Power Sensor	DARE	RPR3006W	15100041SNO91	2017.09.23	2018.09.22
Loop Antenna	SCHWARZBECK	FMZB 1519B	00005	2016.09.29	2018.09.28
Horn Antenna	SCHWARZBECK	BBHA 9170	BBHA 9170294	2017.02.22	2019.02.21
Preamplifier	SCHWARZBECK	BBV9721	9721-031	2017.09.03	2018.09.02
Attenuator	HP	8494B	DC-18G	2017.10.22	2018.10.23
Spectrum analyzer	ROHDE&SCHWARZ	FSQ40	200061	2017.12.28	2018.12.27
Power meter	Agilent	E4419B	GB40202122	2017.09.22	2018.09.21
20dB Attenuator	ICPROBING	IATS1	82347	2017.09.22	2018.09.21
L.I.S.N.#1	Schwarzbeck	NSLK8126	8126466	2017.09.22	2018.09.21

3. SPURIOUS EMISSION

3.1. Test Limits

Frequencies (MHz)	Field Strength (micorvolts/meter)	Measurement Distance (meters)
0.009~0.490	2400/F(KHz)	300
0.490~1.705	24000/F(KHz)	30
1.705~30.0	30	30
30~88	100	3
88~216	150	3
216~960	200	3
Above 960	500	3

Harmonic emissions limits comply with below 54 dBuV/m at 3m. Other emissions radiated outside of the specified frequency bands, except for harmonics, shall be attenuated by at least 50 dB below the level of the fundamental or comply with the radiated emissions limits specified in section 15.209(a) limit in the table below has to be followed.

NOTE:

- a) The tighter limit applies at the band edges.
- b) Emission Level(dB uV/m)=20log Emission Level(uv/m)

3.2. Test Procedure

The measuring distance of 3m shall be used for measurements at frequency up to 1GH and above 1GHz, The EUT was placed on a rotating 0.8 m high above ground for below 1GHz and 1.5m high for above 1GHz testing, The table was rotated 360 degrees to determine the position of the highest radiation

The Test antenna shall vary between 1m and 4m, Both Horizontal and Vertical antenna are set of make measurement.

The initial step in collecting conducted emission data is a spectrum analyzer Peak detector mode pre-scanning the measurement frequency range. Significant Peaks are then marked. and then Qusia Peak Detector mode premeasured

If Peak value comply with QP limit Below 1GHz.The EUT deemed to comply with QP limit. But the Peak value and average value both need to comply with applicable limit above 1GHz.

For the actual test configuration, please see the test setup photo.

3.3. Test Setup

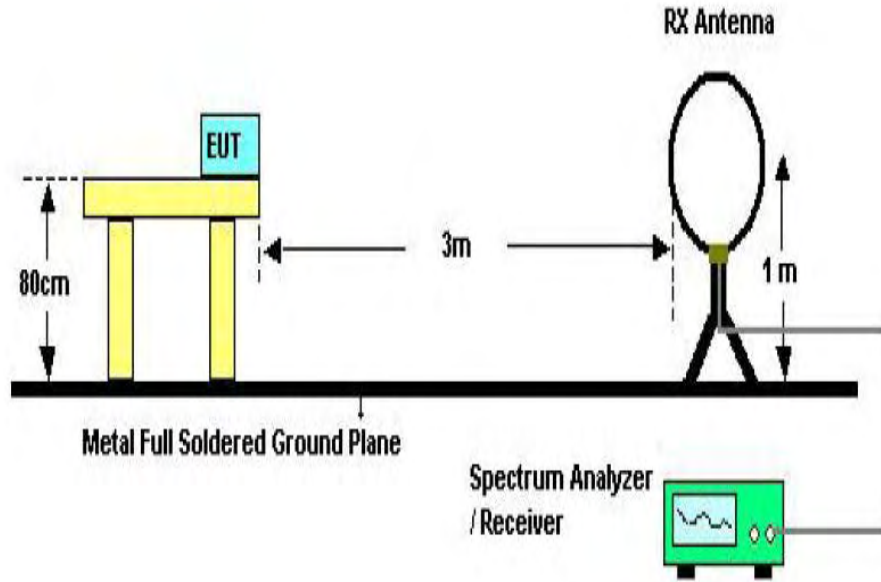

Below 30MHz Test Setup

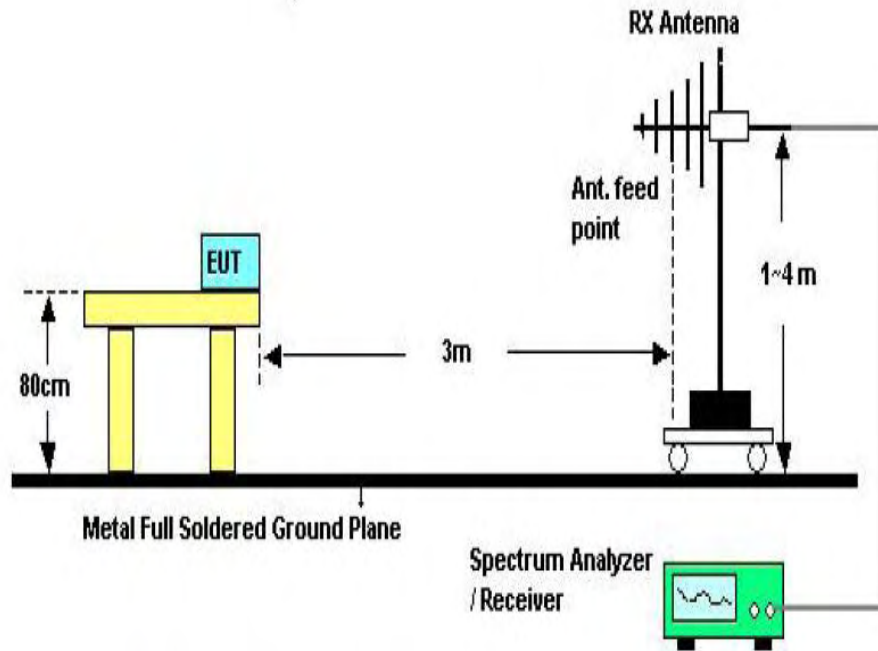

Above 30MHz Test Setup

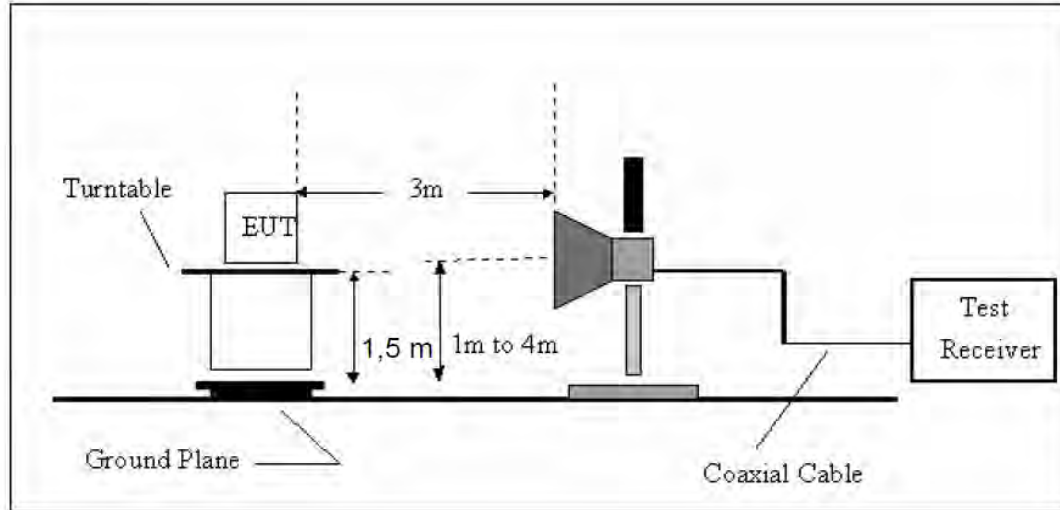

Above 1GHz Test Setup

3.4. Test Results

Test Condition

Continual Transmitting in maximum power.

9KHz~150KHz	RBW200Hz	VBW1KHz
150KHz~30MHz	RBW9KHz	VBW 30KHz
30MHz~1GHz	RBW120KHz	VBW 300KHz
Above1GHz	RBW1MHz	VBW 3MHz

We have scanned the 10th harmonic from 9 kHz to the EUT.

Detailed information please see the following page.

From 9KHz to 30MHz: Conclusion: PASS

Note: 1.The amplitude of spurious emissions which are attenuated by more than 20dB below the permissible value has no need to be reported.

2.Only show the test data of the worst Channel in this report.

Site LAB	Polarization: Vertical	Temperature: 23.9
Limit: FCC Part15 Class B Radiation	Power: AC 120V/60Hz	Humidity: 46 %
EUT: Thiamis Embedded Platform	Distance: 3m	
M/N: Thiamis X module		
Mode: Zigbee 2440		
Note:		
Engineer Signature:		

Radiated Emission Measurement

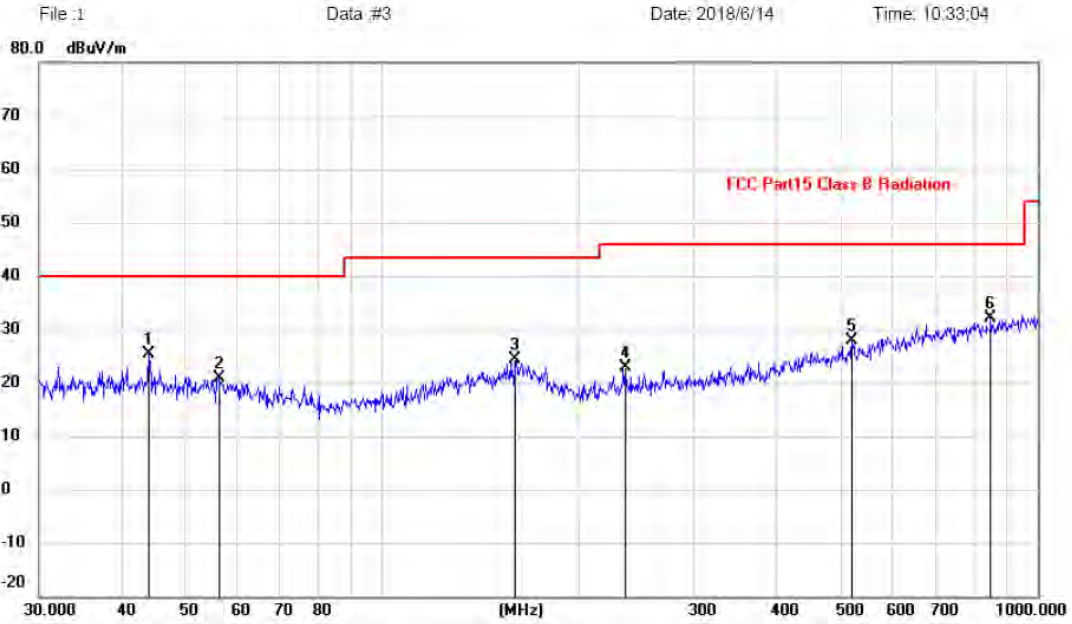

No.	Mk.	Freq.	Reading Level	Correct Factor	Measurement	Limit	Margin	Antenna Height	Table Degree
		MHz	dBuV	dB	dBuV/m	dBuV/m	dB	cm	degree
1		44.1202	11.57	13.85	25.42	40.00	-14.58	peak	
2		56.3948	7.60	13.16	20.76	40.00	-19.24	peak	
3		160.3456	9.78	14.56	24.34	43.50	-19.16	peak	
4		234.1684	11.03	11.87	22.90	46.00	-23.10	peak	
5		520.8882	9.96	17.92	27.88	46.00	-18.12	peak	
6	*	848.0563	9.39	22.68	32.07	46.00	-13.93	peak	

Note:1. *:Maximum data; x:Over limit; !:over margin.
 2.Measurement=Reading Level+Correct Factor; Correct Factor=Antenna Factor+Cable Loss.

Site LAB	Polarization: <i>Horizontal</i>	Temperature: 23.8
Limit: FCC Part15 Class B Radiation	Power: AC 120V/60Hz	Humidity: 48 %
EUT: Thiamis Embedded Platform	Distance: 3m	
M/N: Thiamis X module		
Mode: Zigbee 2440		
Note:		
Engineer Signature:		

Radiated Emission Measurement

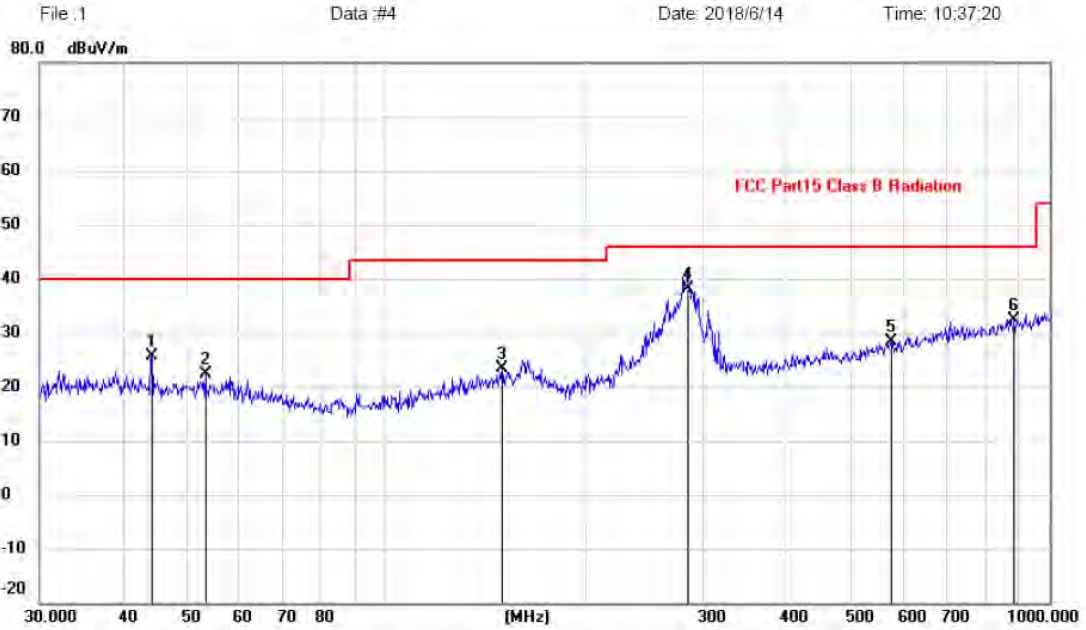

No.	Mk.	Freq.	Reading Level	Correct Factor	Measurement	Limit	Margin	Antenna Height	Table Degree	
		MHz	dBuV	dB	dBuV/m	dBuV/m	dB	cm	degree	Comment
1		44.2752	11.73	13.82	25.55	40.00	-14.45			peak
2		53.3179	8.91	13.44	22.35	40.00	-17.65			peak
3		149.4857	8.77	14.52	23.29	43.50	-20.21			peak
4	*	284.9767	24.97	13.04	38.01	46.00	-7.99			QP
5		576.6443	9.36	18.99	28.35	46.00	-17.65			peak
6		887.6099	9.64	22.83	32.47	46.00	-13.53			peak

Note:1. *:Maximum data; x:Over limit; !:over margin.
 2.Measurement=Reading Level+Correct Factor; Correct Factor=Antenna Factor+Cable Loss.

Notes: Above is below 1GHz test data. This report only shall the worst case mode for TX 2440MHz.

From 1G-25GHz

Test Mode: TX Low									
Freq (MHz)	Read Level (dBuV/m)	Polar (H/V)	Antenna Factor (dB/m)	Cable loss(dB)	Amp Factor (dB)	Result (dBuV/m)	Limit (dBuV/m)	Margin (dB)	Remark
4810	43.74	V	33.95	10.18	34.26	53.61	74	20.39	PK
4810	34.43	V	33.95	10.18	34.26	44.30	54	9.70	AV
7215	/		/						
9620	/		/						
4810	43.58	H	33.95	10.18	34.26	53.45	74	20.55	PK
4810	34.30	H	33.95	10.18	34.26	44.17	54	9.83	AV
7215									
9620									
Test Mode: TX Mid									
4880	41.44	V	33.93	10.2	34.29	51.28	74	22.72	PK
4880	32.31	V	33.93	10.2	34.29	42.15	54	11.85	AV
7320	/								
9760	/								
4880	41.85	H	33.93	10.2	34.29	51.69	74	22.31	PK
4880	32.42	H	33.93	10.2	34.29	42.26	54	11.74	AV
7320									
9760									
Test Mode: TX High									
4960	42.64	V	33.98	10.22	34.25	52.59	74	21.41	PK
4960	32.53	V	33.98	10.22	34.25	42.48	54	11.52	AV
7440	/								
9920	/								
4960	42.32	H	33.98	10.22	34.25	52.27	74	21.73	PK
4960	32.29	H	33.98	10.22	34.25	42.24	54	11.76	AV
7440	/								
9920	/								
Note:									
1, Result = Read level + Antenna factor + cable loss-Amp factor									
2, All the other emissions not reported were too low to read and deemed to comply with FCC limit.									

4. POWER LINE CONDUCTED EMISSION

4.1. Test Limits

Frequency MHz	Limits dB(μ V)	
	Quasi-peak Level	Average Level
0.15 -0.50	66 -56*	56 - 46*
0.50 -5.00	56	46
5.00 -30.00	60	50

- Notes: 1. *Decreasing linearly with logarithm of frequency.
 2. The lower limit shall apply at the transition frequencies.
 3. The limit decreases in line with the logarithm of the frequency in rang of 0.15 to 0.50 MHz.

4.2. Test Procedure

The EUT is put on the plane 0.8m high above the ground by insulating support and is connected to the power mains through a line impedance stabilization network (L.I.S.N.). This provides a 50ohm coupling impedance for the EUT system. Please refer the block diagram of the test setup and photographs. Both sides of AC lines are checked to find out the maximum conducted emission. In order to find the maximum emission levels, the relative positions of equipment and all of the interface cables shall be changed according to ANSI C63.10:2013 on Conducted Emission Measurement.

The bandwidth of test receiver is set at 9 kHz.

4.3. Test Setup

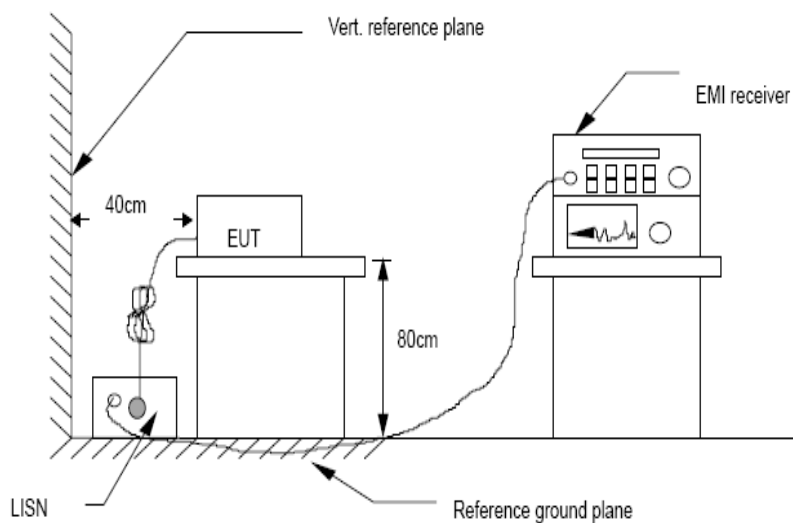

4.4. Test Results

Site LAB
 Limit: FCC Part 15 CLASS B QP
 EUT: Thiamis Embedded Platform
 M/N: Thiamis X module
 Mode: Zigbee 2440
 Note:
 Engineer Signature:

Phase: **N**
 Power: AC 120V/60Hz

Temperature: 24.9
 Humidity: 47 %

Conducted Emission Measurement

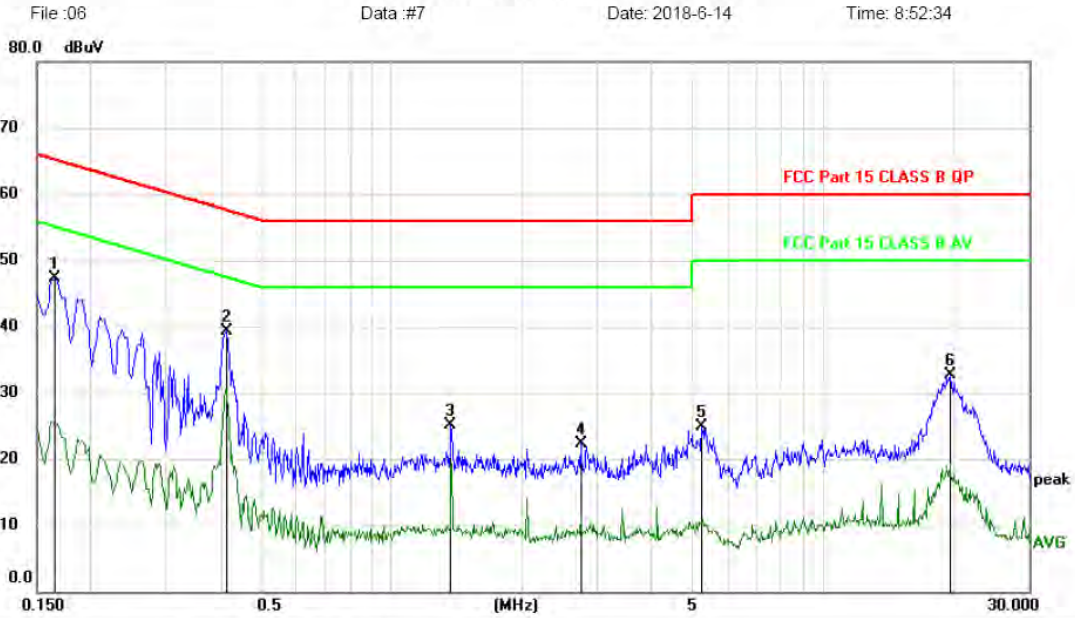

No.	Mk.	Freq. MHz	Reading Level dBuV	Correct Factor dB	Measure- ment dBuV	Limit dBuV	Margin dB	Detector	Comment
1	*	0.1650	37.53	9.73	47.26	65.21	-17.95	peak	
2		0.4140	29.54	9.78	39.32	57.57	-18.25	peak	
3		1.3710	15.33	9.86	25.19	56.00	-30.81	peak	
4		2.7449	12.38	10.02	22.40	56.00	-33.60	peak	
5		5.2440	14.63	10.20	24.83	60.00	-35.17	peak	
6		19.7280	22.12	10.50	32.62	60.00	-27.38	peak	

*:Maximum data x:Over limit !:over margin

Note: Measurement=Reading Level+Correc Factor. Factor=(LISN or ISN or PLC or Current Probe)Factor+Cable

Site LAB
 Limit: FCC Part 15 CLASS B QP
 EUT: Thiamis Embedded Platform
 M/N: Thiamis X module
 Mode: Zigbee 2440
 Note:
 Engineer Signature:

Phase: **L1**
 Power: AC 120V/60Hz

Temperature: 24.9
 Humidity: 47 %

Conducted Emission Measurement

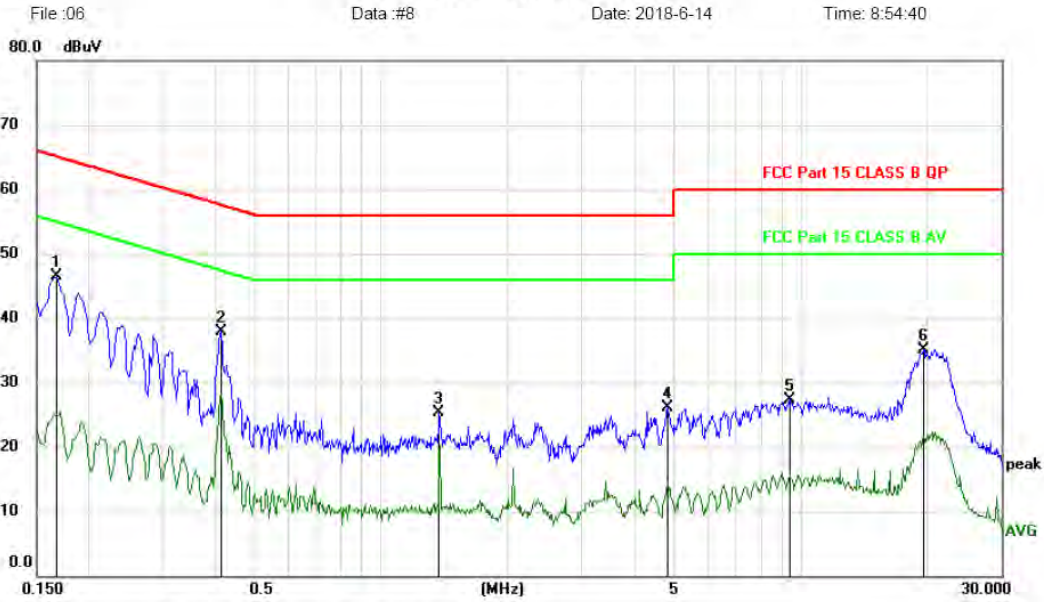

No.	Mk.	Freq. MHz	Reading Level dBuV	Correct Factor dB	Measure- ment dBuV	Limit dBuV	Margin dB	Detector	Comment
1	*	0.1680	36.83	9.73	46.56	65.06	-18.50	peak	
2		0.4140	28.22	9.78	38.00	57.57	-19.57	peak	
3		1.3710	15.43	9.86	25.29	56.00	-30.71	peak	
4		4.8029	15.85	10.18	26.03	56.00	-29.97	peak	
5		9.3600	16.97	10.32	27.29	60.00	-32.71	peak	
6		19.6290	24.60	10.48	35.08	60.00	-24.92	peak	

*:Maximum data x:Over limit !:over margin

Note: Measurement=Reading Level+Correc Factor. Factor=(LISN or ISN or PLC or Current Probe)Factor+Cable

Remark: All modes and channels have been tested and only listed ZigBee Tx 2440MHz mode that is worst data

5. CONDUCTED MAXIMUM OUTPUT POWER

5.1. Test limits

Please refer section RSS-247 & 15.247.

5.2. Test Procedure

Details see the KDB558074 D01 Meas Guidance V04

5.2.1 Place the EUT on the table and set it in transmitting mode.

5.2.2 Measure out each mode and each bands peak output power of EUT.

Note: The cable loss and attenuator loss were offset into measure device as amplitude offset.

5.3. Test Setup

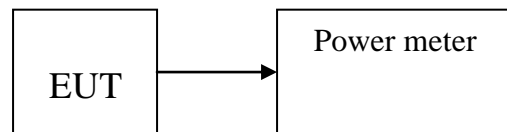

5.4. Test Results

Channel	Frequency (MHz)	PK Output Power (dBm)	PK Output Power (mW)	Limit (dBm)
CH1	2405	-1.153	0.767	30
CH8	2440	-0.953	0.804	30
CH16	2480	-1.473	0.712	30
Conclusion: PASS				

6. PEAK POWER SPECTRAL DENSITY

6.1. Test limits

6.1.1 Please refer section RSS-247 & 15.247.

6.1.2 For direct sequence systems, the peak power spectral density conducted from the intentional radiator to the antenna shall not be greater than 8dBm in any 3kHz band during any time interval of continuous transmission.

6.1.3 The direct sequence operating of the hybrid system, with the frequency hopping operation turned off, shall comply with the power density requirements of paragraph (d) of this section.

6.2. Test Procedure

Details see the KDB558074 D01 Meas Guidance V04

6.2.1 Place the EUT on the table and set it in transmitting mode.

6.2.2 Remove the antenna from the EUT and then connect a low loss RF cable from the antenna port to the spectrum analyzer.

6.2.3 Set the spectrum analyzer as $RBW = 10\text{kHz}$ (Set the RBW to: $3\text{ kHz} \leq RBW \leq 100\text{ kHz}$.), $VBW = 30\text{kHz}$ (Set the $VBW \geq 3 \times RBW$), $\text{span} = 1.5 \times \text{DTS bandwidth}$., detail see the test plot.

6.2.4 Record the max reading.

6.2.5 Repeat the above procedure until the measurements for all frequencies are completed.

6.3. Test Setup

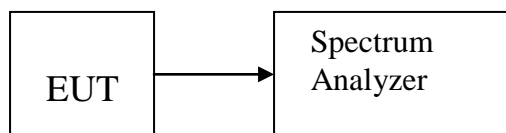

6.4. Test Results

Channel	Frequency (MHz)	Power Spectral Density (dBm)	Limit (dBm)	Result
CH1	2405	-10.894	8	PASS
CH8	2440	-11.369	8	PASS
CH16	2480	-11.319	8	PASS

Conclusion: PASS

CH Low :



CH Mid:



CH High:



7. BANDWIDTH

7.1. Test limits

Please refer section RSS-247 & 15.247

For direct sequence systems, the minimum 6dB bandwidth shall be at least 500 kHz.

7.2. Test Procedure

Details see the KDB558074 D01 Meas Guidance V04

a) The bandwidth is measured at an amplitude level reduced 20dB from the reference level. The reference level is the level of the highest amplitude signal observed from the transmitter at the fundamental frequency. Once the reference level is established, the equipment is conditioned with typical modulating signal to produce the worst-case (i.e. the widest) bandwidth.

b) The test receiver set RBW = 100kHz, VBW $\geq 3 \cdot$ RBW = 300kHz, Sweep time set auto, detail see the test plot.

7.3. Test Setup

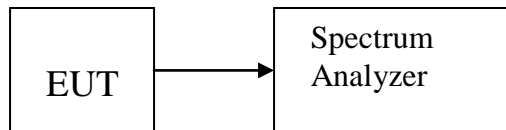

7.4. Test Results

Channel	Frequency (MHz)	6dB Bandwidth (MHz)	Limit (MHz)	Result
CH1	2405	1.582	0.5	PASS
CH8	2440	1.482	0.5	PASS
CH16	2480	1.432	0.5	PASS

:
CH Low :



CH Mid :



CH High :



8. BAND EDGE CHECK

8.1. Test limits

Please refer section RSS-GEN&15.247.

8.2. Test Procedure

Details see the KDB558074 D01 Meas Guidance V04

8.2.1 Put the EUT on a 0.8m high table, power on the EUT. Emissions were scanned and measured rotating the EUT to 360 degrees, Find the maximum Emission

8.2.2 Check the spurious emissions out of band.

8.2.3 RBW 1MHz ,VBW 3MHz ,peak detector for peak value , RBW 1MHz ,VBW 3MHz ,RMS detector for AV value.

8.3. Test Setup

Same as 5.2.2.

8.4. Test Results

Radiated Test Plots:

Note: 1. *:Maximum data; x:Over limit; !:over margin.

2.Measurement=Reading Level+Correct Factor; Correct Factor=Antenna Factor+Cable Loss.

O-QPSK

CH LOW :

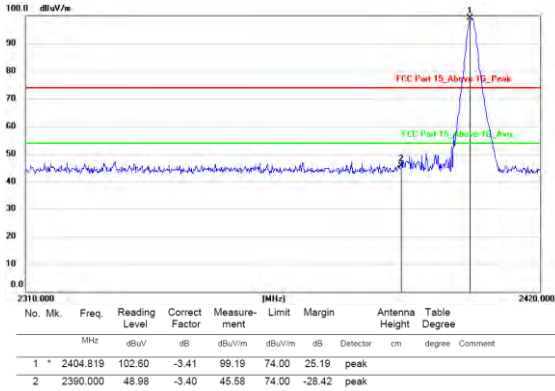

Vertical

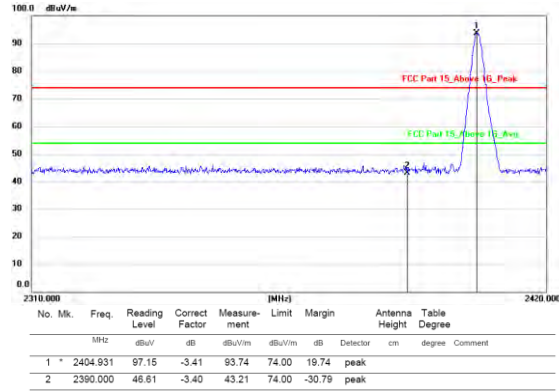

Horizontal

CH High :

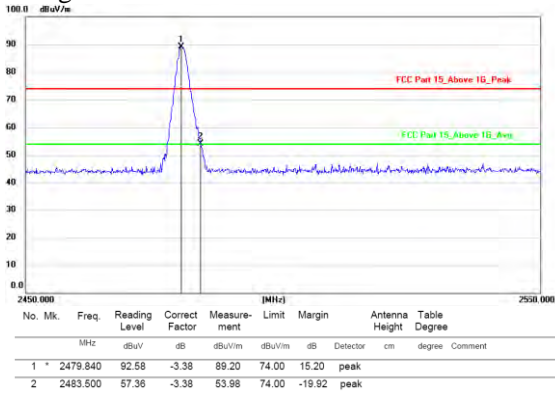

Vertical

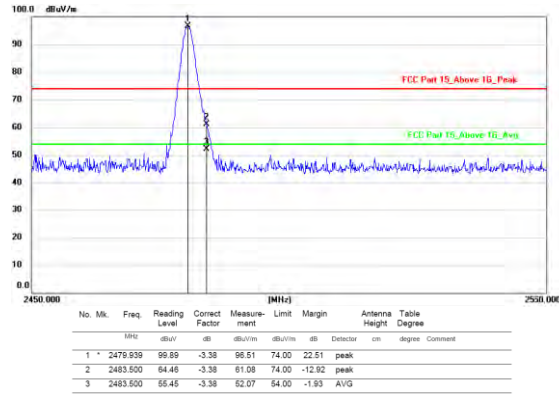

Horizontal

9. ANTENNA REQUIREMENT

9.1. Standard Requirement

An intentional radiator shall be designed to ensure that no antenna other than that furnished by the responsible party shall be used with the device. The use of a permanently attached antenna or of an antenna that uses a unique coupling to the intentional radiator shall be considered sufficient to comply with the provisions of this Section. The manufacturer may design the unit so that a broken antenna can be replaced by the user, but the use of a standard antenna jack or electrical connector is prohibited.

9.2. Antenna Connected Construction

The antenna is Ceramics antenna and no consideration of replacement. Please see EUT photo for details.

9.3. Results

The EUT antenna is Ceramics Antenna. It complies with the standard requirement.

10. TEST SETUP PHOTO

10.1.Photos of Radiated emission

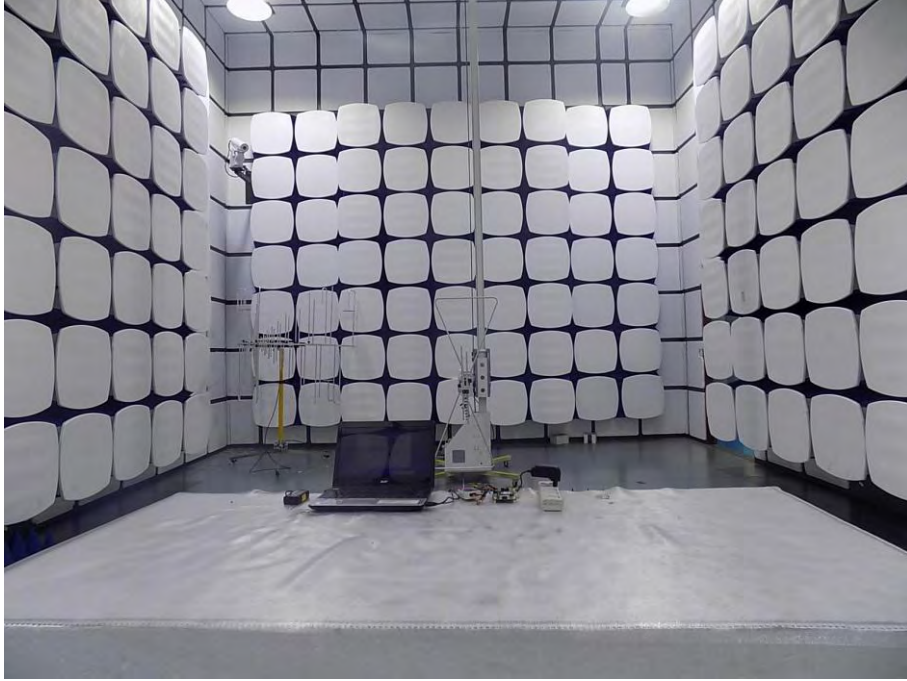

10.2.Photos of Conducted Emission test



11. TEST SETUP PHOTO

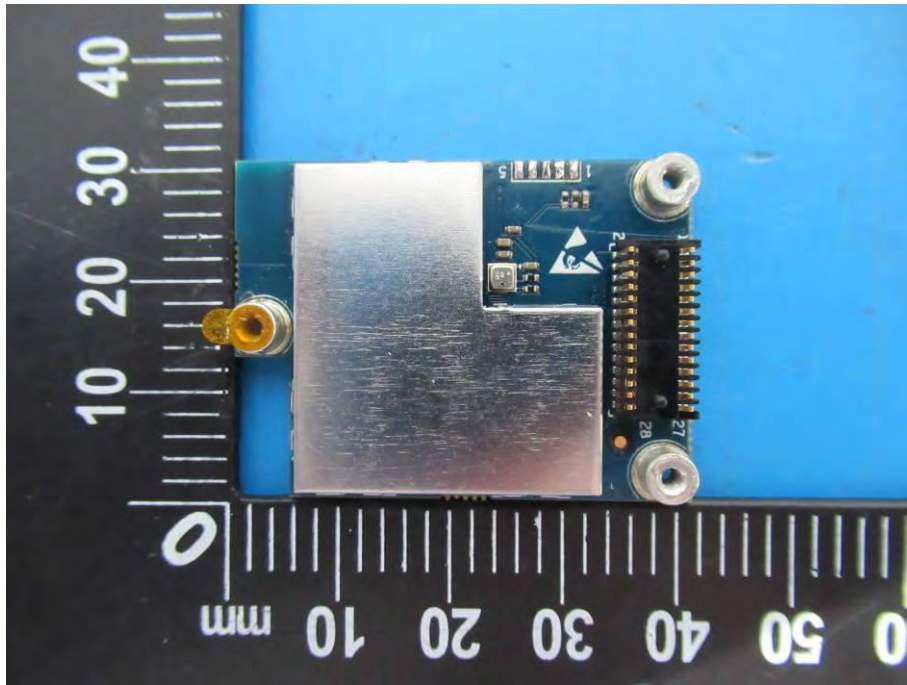
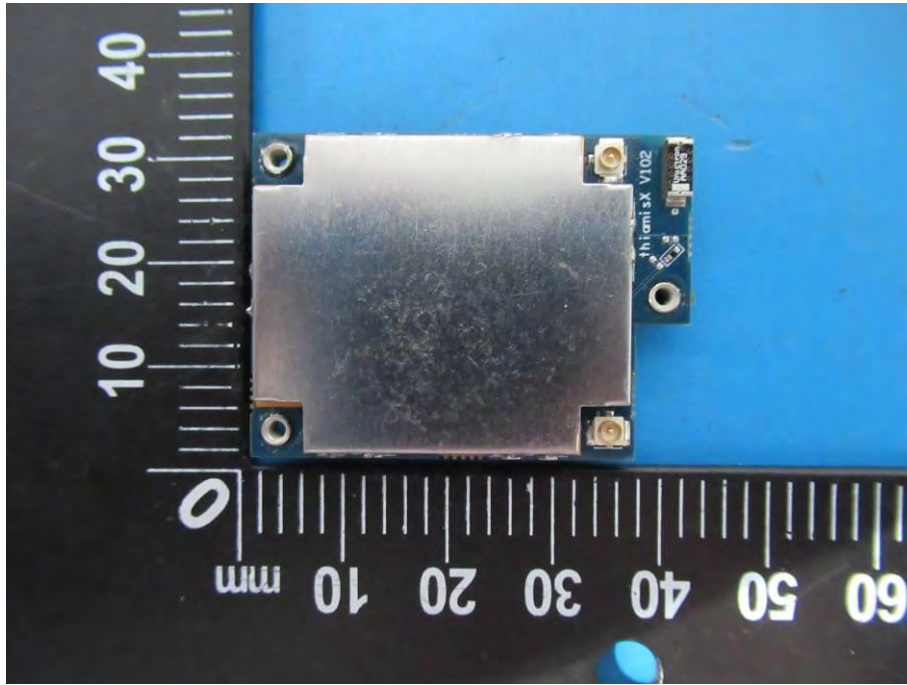

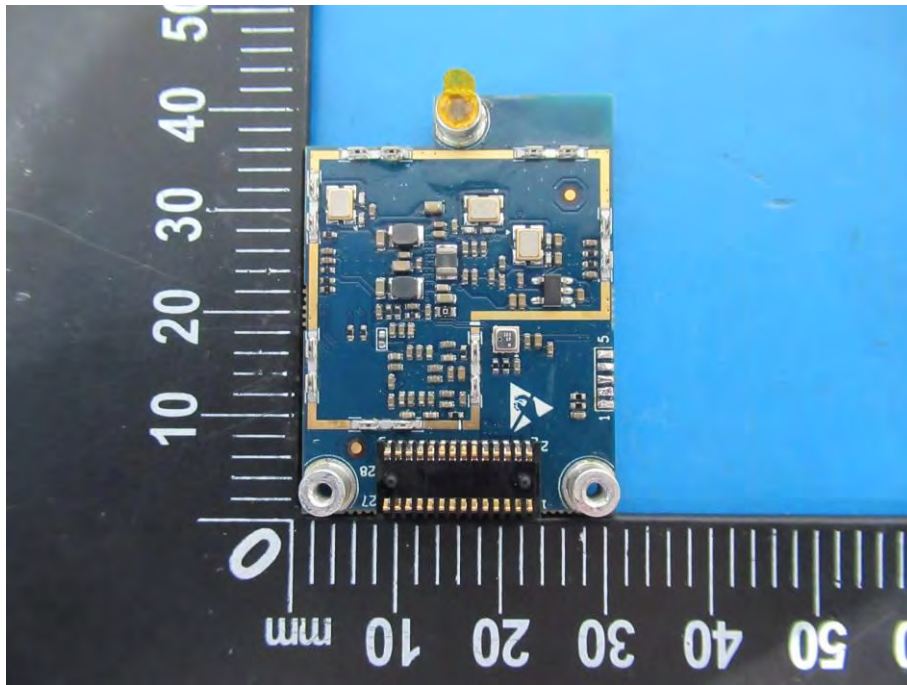
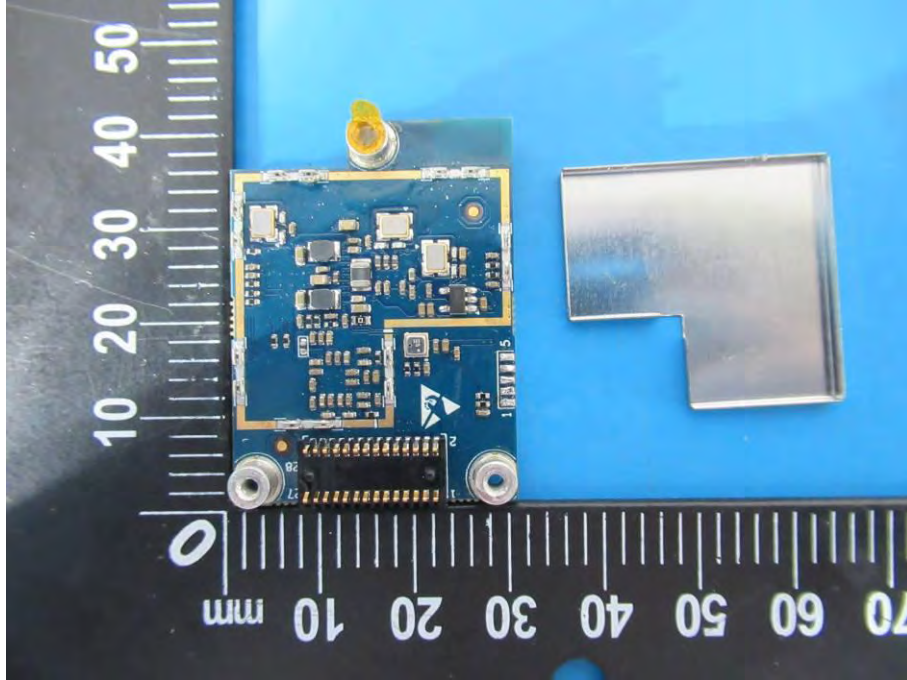

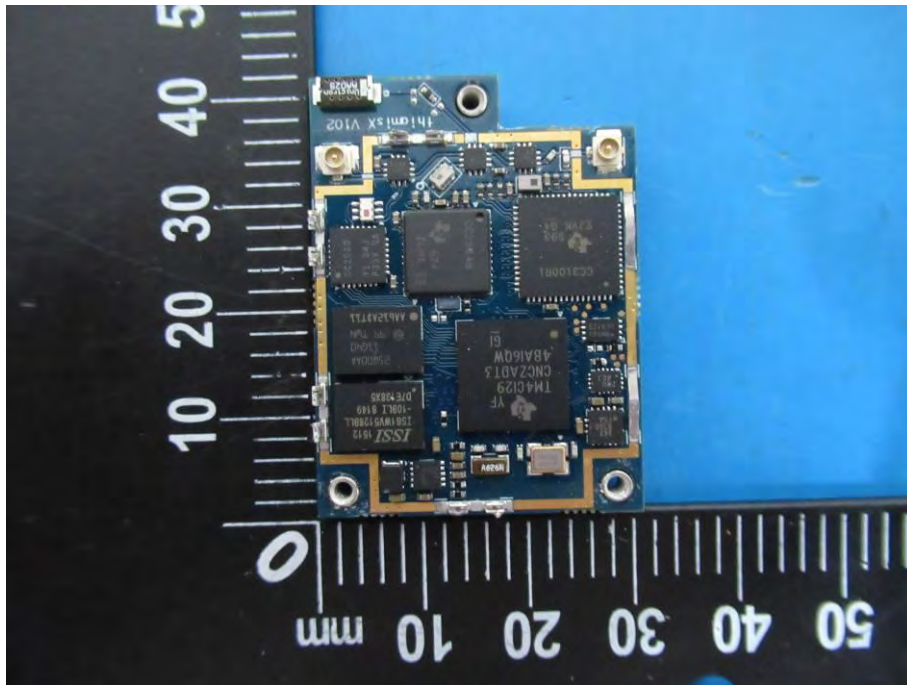
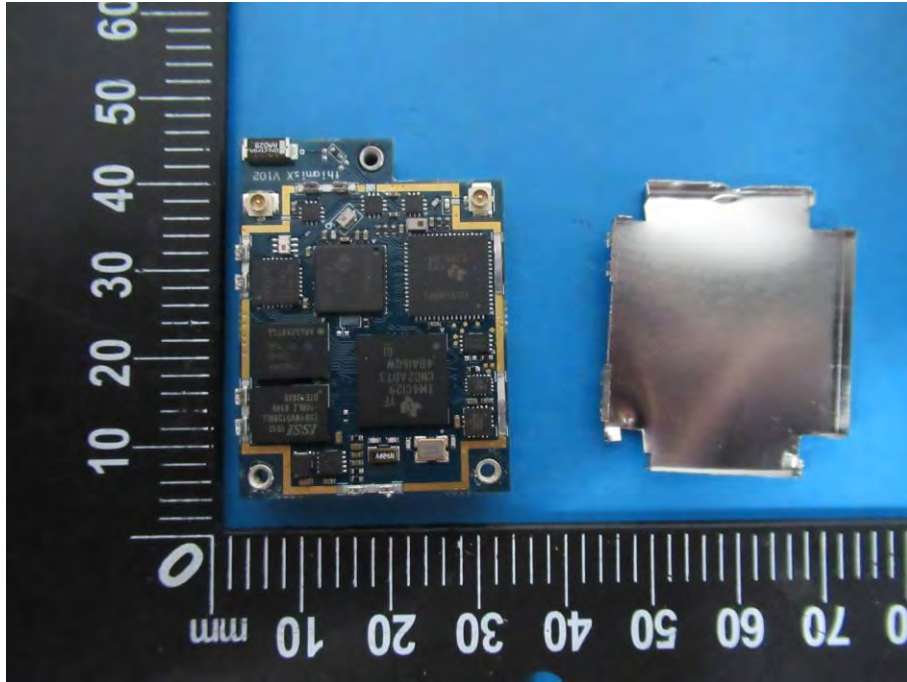

-----THE END OF REPORT-----