

FCC TEST REPORT

FCC ID:2AN97-DF-C30

Report Number..... : ZKT-230321L1889

Date of Test..... : Mar. 6, 2023 -- Mar. 28, 2023

Date of issue..... : Mar. 28, 2023

Total number of pages..... : 28

Test Result : PASS

Testing Laboratory..... : Shenzhen ZKT Technology Co., Ltd.

Address : 1/F, No. 101, Building B, No. 6, Tangwei Community Industrial Avenue, Fuhai Street, Bao'an District, Shenzhen, China

Applicant's name : Shenzhen Top-Peak Electronics Co.,Ltd

Address : 4th Floor,Building,Tengfeng 3rd Road,Fenghuang,Fuyong,Ban'an District,Shenzhen,China

Manufacturer's name : Shenzhen Top-Peak Electronics Co.,Ltd

Address : 4th Floor,Building,Tengfeng 3rd Road,Fenghuang,Fuyong,Ban'an District,Shenzhen,China

Test specification:

Standard..... : FCC CFR Title 47 Part 15 Subpart C Section 15.249
ANSI C63.10:2013

Test procedure..... : N/A

Non-standard test method : N/A

Test Report Form No..... : TRF-EL-111_V0

Test Report Form(s) Originator..... : ZKT Testing

Master TRF : Dated: 2020-01-06

This device described above has been tested by ZKT, and the test results show that the equipment under test (EUT) is in compliance with the FCC requirements. And it is applicable only to the tested sample identified in the report.

This report shall not be reproduced except in full, without the written approval of ZKT, this document may be altered or revised by ZKT, personal only, and shall be noted in the revision of the document.

Product name..... : Remote control multi-rotor plant protection UAV

Trademark : 
鼎峰无限

Model/Type reference..... : DF-C30,DF-C50,DF-T10,DF-T16,DF-T26,DF-D16

Ratings..... : DC 53.2V/28A from Battery

Testing procedure and testing location:

Testing Laboratory.....: **Shenzhen ZKT Technology Co., Ltd.**

Address.....: 1/F, No. 101, Building B, No. 6, Tangwei Community
Industrial Avenue, Fuhai Street, Bao'an District,
Shenzhen, China

Tested by (name + signature).....: Alen He

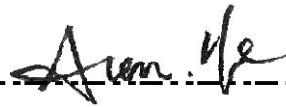

Reviewer (name + signature).....: Joe Liu

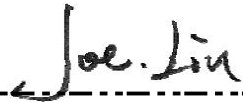

Approved (name + signature).....: Lake Xie



Table of Contents	Page
1.VERSION	4
2.SUMMARY OF TEST RESULTS	5
2.1 TEST FACILITY	5
2.2 MEASUREMENT UNCERTAINTY	5
3. GENERAL INFORMATION	5
3.1 GENERAL DESCRIPTION OF EUT	6
3.2 DESCRIPTION OF TEST MODES	6
3.3 BLOCK DIGRAM SHOWING THE CONFIGURATION OF SYSTEM TESTED	7
3.4 DESCRIPTION OF SUPPORT UNITS(CONDUCTED MODE)	7
3.5 EQUIPMENTS LIST FOR ALL TEST ITEMS	8
4. EMC EMISSION TEST	9
4.1 RADIATED EMISSION MEASUREMENT	9
4.2.1 RADIATED EMISSION LIMITS	9
4.2.2 TEST PROCEDURE	10
4.2.3 DEVIATION FROM TEST STANDARD	10
4.2.4 TEST SETUP	10
4.2.5 EUT OPERATING CONDITIONS	11
5. BAND EDGE	19
5.1 TEST REQUIREMENT:	19
5.2 TEST PROCEDURE	19
5.3 DEVIATION FROM TEST STANDARD	19
5.4 TEST SETUP	20
5.5 EUT OPERATING CONDITIONS	20
6. CHANNEL BANDWIDTH	22
6.1 APPLIED PROCEDURES / LIMIT	22
6.2 TEST PROCEDURE	22
6.3 DEVIATION FROM STANDARD	22
6.4 TEST SETUP	22
6.5 EUT OPERATION CONDITIONS	22
6.6 TEST RESULTS	23
7. ANTENNA REQUIREMENT	27
8. TEST SETUP PHOTO	28
9. EUT CONSTRUCTIONAL DETAILS	28

1.VERSION

Report No.	Version	Description	Approved
ZKT-230321L1889	Rev.01	Initial issue of report	Mar. 28, 2023

2.SUMMARY OF TEST RESULTS

Test procedures according to the technical standards:

FCC Part15 (15.249) , Subpart C			
Standard Section	Test Item	Judgment	Remark
FCC part 15.203	Antenna requirement	PASS	
FCC part 15.207	AC Power Line Conducted Emission	N/A	
FCC part 15.249	Fundamental & Radiated Spurious Emission Measurement	PASS	
FCC part 15.215(c)	20dB Channel Bandwidth	PASS	
FCC part 15.249&15.209	Band Edge	PASS	

NOTE:

(1)" N/A" denotes test is not applicable in this Test Report

2.1 TEST FACILITY

Shenzhen ZKT Technology Co., Ltd.

Add. : 1/F, No. 101, Building B, No. 6, Tangwei Community Industrial Avenue, Fuhai Street, Bao'an District, Shenzhen, China

FCC Test Firm Registration Number: 692225

Designation Number: CN1299

IC Registered No.: 27033

2.2 MEASUREMENT UNCERTAINTY

The reported uncertainty of measurement $y \pm U$, where expanded uncertainty U is based on a standard uncertainty multiplied by a coverage factor of $k=2$, providing a level of confidence of approximately 95 % .

No.	Item	Uncertainty
1	Conducted Emission Test	$\pm 1.38\text{dB}$
2	RF power conducted	$\pm 0.16\text{dB}$
3	Spurious emissions conducted	$\pm 0.21\text{dB}$
4	All emissions radiated(<1G)	$\pm 4.68\text{dB}$
5	All emissions radiated(>1G)	$\pm 4.89\text{dB}$
6	Temperature	$\pm 0.5^{\circ}\text{C}$
7	Humidity	$\pm 2\%$

3. GENERAL INFORMATION

3.1 GENERAL DESCRIPTION OF EUT

Product Name:	Remote control multi-rotor plant protection UAV
Model No.:	DF-C30
Serial No.:	DF-C50/DF-T10/DF-T16/DF-T26/DF-D16
Model difference:	Their electrical circuit design, layout, components used and internal wiring are identical, Only the color will be different ,so the name will be different. Test sample model:DF-C30
Hardware Version:	V1.0
Software Version:	V1.0
Sample(s) Status:	Engineer sample
Channel numbers:	2
Channel separation:	2403MHz~2478MHz
Modulation technology:	FSK
Antenna Type:	External antenna
Antenna gain:	ANT1:2dBi;ANT2:2dBi
Power supply:	DC 53.2V/28A from Battery

Test Frequency:

Test channel	Frequency (MHz)	Test channel	Frequency (MHz)
1	2403	5	2449
2	2420	6	2470
3	2429	7	2473
4	2432	8	2478

Note:

In section 15.31(m), regards to the operating frequency range over 10 MHz, the Lowest frequency, the middle frequency, and the highest frequency of channel were selected to perform the test, and the selected channel see below:

Test channel	Frequency (MHz)
The lowest channel	2403
The middle channel	2432
The Highest channel	2478

3.2 DESCRIPTION OF TEST MODES

Transmitting mode	Keep the EUT in continuously transmitting mode
Remark: During the test, the test voltage was tuned from 85% to 115% of the nominal rated supply voltage, and found that the worst case was under the nominal rated supply condition. So the report just shows that condition's data.	

3.3 BLOCK DIGRAM SHOWING THE CONFIGURATION OF SYSTEM TESTED

Conducted Emission



Radiated Emission

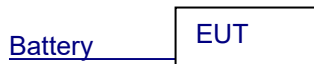

Conducted Spurious



3.4 DESCRIPTION OF SUPPORT UNITS(CONDUCTED MODE)

The EUT has been tested as an independent unit together with other necessary accessories or support units. The following support units or accessories were used to form a representative test configuration during the tests.

Item	Equipment	Mfr/Brand	Model/Type No.	Series No.	Note
1	Battery	53.2V/28A	N/A	N/A	N/A

Note:

- (1) The support equipment was authorized by Declaration of Confirmation.
- (2) For detachable type I/O cable should be specified the length in cm in 『Length』 column.

3.5 EQUIPMENTS LIST FOR ALL TEST ITEMS

Radiation Test equipment

Item	Equipment	Manufacturer	Type No.	Serial No.	Last calibration	Calibrated until
1	Spectrum Analyzer (9kHz-26.5GHz)	KEYSIGHT	9020A	MY55370835	Oct. 18, 2022	Oct. 17, 2023
2	Spectrum Analyzer (1GHz-40GHz)	R&S	FSQ	100363	Oct. 17, 2022	Oct. 16, 2023
3	EMI Test Receiver (9kHz-7GHz)	R&S	ESCI7	101169	Oct. 18, 2022	Oct. 17, 2023
4	Bilog Antenna (30MHz-1500MHz)	Schwarzbeck	VULB9168	N/A	Oct. 17, 2022	Oct. 16, 2023
5	Horn Antenna (1GHz-18GHz)	Agilent	AH-118	071145	Oct. 17, 2022	Oct. 16, 2023
6	Loop Antenna	TESEQ	HLA6121	58357	Oct. 17, 2022	Oct. 16, 2023
7	Amplifier (30-1000MHz)	EM Electronics	EM330 Amplifier	060747	Oct. 17, 2022	Oct. 16, 2023
8	Amplifier (1GHz-26.5GHz)	Agilent	8449B	3008A00315	Oct. 18, 2022	Oct. 17, 2023
9	RF cables1 (9kHz-30MHz)	N/A	9kHz-30MHz	N/A	Oct. 18, 2022	Oct. 17, 2023
10	RF cables2 (30MHz-1GHz)	N/A	30MHz-1GHz	N/A	Oct. 18, 2022	Oct. 17, 2023
11	RF cables3 (1GHz-40GHz)	N/A	1GHz-40GHz	N/A	Oct. 18, 2022	Oct. 17, 2023
12	ESG Signal Generator	Agilent	E4421B	N/A	Oct. 18, 2022	Oct. 17, 2023
13	Signal Generator	Agilent	N5182A	N/A	Oct. 22, 2022	Oct. 21, 2023
14	Magnetic Field Probe Tester	Narda	ELT-400	0-0344	Oct. 17, 2022	Oct. 16, 2023
15	MWRF Power Meter Test system	MW	MW100-RPCB	N/A	Oct. 22, 2022	Oct. 21, 2023
16	Power sensor	KEYSIGHT	U2002H	MY51190005	Oct. 22, 2022	Oct. 21, 2023
17	D.C. Power Supply	LongWei	TPR-6405D	N/A	\	\
18	EMC Software	Frad	EZ-EMC	Ver.EMC-CON 3A1.1	\	\
19	RF Software	MW	MTS8310	V2.0.0.0	\	\
20	Turntable	MF	MF-7802BS	N/A	\	\
21	Antenna tower	MF	MF-7802BS	N/A	\	\

Conduction Test equipment

Item	Equipment	Manufacturer	Type No.	Serial No.	Last calibration	Calibrated until
1	LISN	R&S	ENV216	101471	Oct. 22, 2022	Oct. 21, 2023
2	LISN	CYBERTEK	EM5040A	E1850400149	Oct. 22, 2022	Oct. 21, 2023
3	Test Cable	N/A	C01	N/A	Oct. 18, 2022	Oct. 17, 2023
4	Test Cable	N/A	C02	N/A	Oct. 18, 2022	Oct. 17, 2023
5	EMI Test Receiver	R&S	ESCI3	101393	Oct. 17, 2022	Oct. 16, 2023
6	EMC Software	Frad	EZ-EMC	Ver.EMC-CON 3A1.1	\	\

4. EMC EMISSION TEST

4.1 RADIATED EMISSION MEASUREMENT

Test Requirement:	FCC Part15 C Section 15.209				
Test Method:	ANSI C63.10:2013				
Test Frequency Range:	9kHz to 25GHz				
Test site:	Measurement Distance: 3m				
Receiver setup:	Frequency	Detector	RBW	VBW	Value
	9KHz-10KHz	Quasi-peak	200Hz	600Hz	Quasi-peak
	150KHz-30MHz	Quasi-peak	9KHz	30KHz	Quasi-peak
	30MHz-1GHz	Quasi-peak	100KHz	300KHz	Quasi-peak
	Above 1GHz	Peak	1MHz	3MHz	Peak
Peak		1MHz	10Hz	Average	

4.2.1 RADIATED EMISSION LIMITS

Frequencies (MHz)	Field Strength (micorvolts/meter)	Measurement Distance (meters)
0.009~0.490	2400/F(KHz)	300
0.490~1.705	24000/F(KHz)	30
1.705~30.0	30	30
30~88	100	3
88~216	150	3
216~960	200	3
Above 960	500	3

The field strength of emissions from intentional radiators operated within these frequency bands shall comply with the following:

Fundamental frequency	Field strength of fundamental (millivolts/meter)	Field strength of harmonics (microvolts/meter)
902-928 MHz	50	500
2400-2483.5 MHz	50	500
5725-5875 MHz	50	500
24.0-24.25 GHz	250	2500

LIMITS OF RADIATED EMISSION MEASUREMENT

FREQUENCY (MHz)	Limit (dBuV/m) (at 3M)	
	PEAK	AVERAGE
Above 1000	74	54

Notes:

- (1) The limit for radiated test was performed according to FCC PART 15C.
- (2) The tighter limit applies at the band edges.
- (3) Emission level (dBuV/m)=20log Emission level (uV/m).

4.2.2 TEST PROCEDURE

- a. The measuring distance of at 3 m shall be used for measurements at frequency up to 25GHz. For frequencies above 1GHz, any suitable measuring distance may be used.
- b. The EUT was placed on the top of a rotating table 0.1 meters above the ground at a 3 meter semi-chamber test. The table was rotated 360 degrees to determine the position of the highest radiation.
- c. The height of the equipment or of the substitution antenna shall be 0.1m; above 1GHz, the height was 1.5m, the height of the test antenna shall vary between 1 m to 4 m. Both horizontal and vertical polarizations of the antenna are set to make the measurement.
- d. The initial step in collecting conducted emission data is a spectrum analyzer peak detector mode pre-scanning the measurement frequency range. Significant peaks are then marked and then Quasi Peak detector mode re-measured.
- e. If the Peak Mode measured value compliance with and lower than Quasi Peak Mode Limit, the EUT shall be deemed to meet QP Limits and then no additional QP Mode measurement performed.
- f. For the actual test configuration, please refer to the related Item –EUT Test Photos.
- g. For the radiated emission test above 1GHz:
Place the measurement antenna away from each area of the EUT determined to be a source of emissions at the specified measurement distance, while keeping the measurement antenna aimed at the source of emissions at each frequency of significant emissions, with polarization oriented for maximum response.

The measurement antenna may have to be higher or lower than the EUT, depending on the radiation pattern of the emission and staying aimed at the emission source for receiving the maximum signal. The final measurement antenna elevation shall be that which maximizes the emissions. The measurement antenna elevation for maximum emissions shall be restricted to a range of heights of from 1 m to 4 m above the ground or reference ground plane.

Note:

Both horizontal and vertical antenna polarities were tested and performed pretest to three orthogonal axis. The worst case emissions were reported

4.2.3 DEVIATION FROM TEST STANDARD

No deviation

4.2.4 TEST SETUP

(A) Radiated Emission Test-Up Frequency Below 30MHz

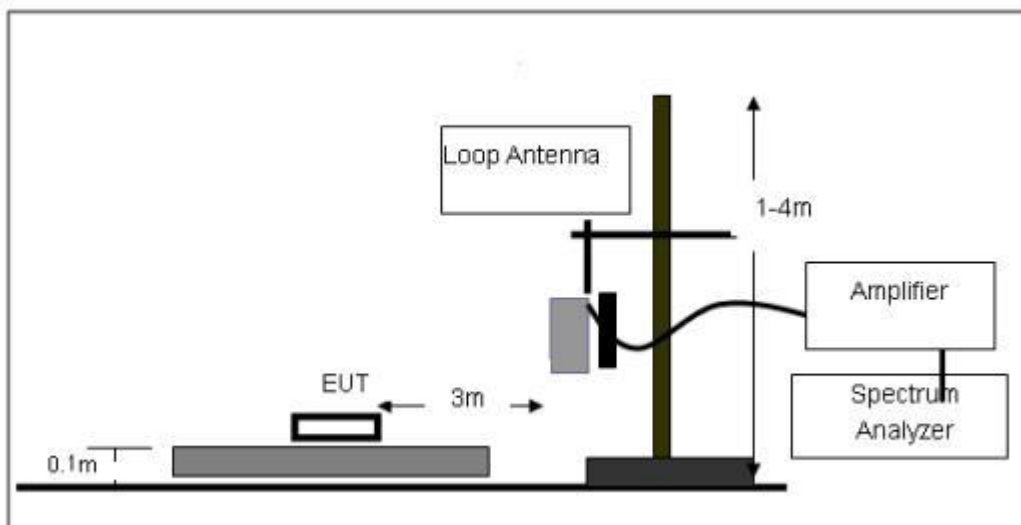

(B) Radiated Emission Test-Up Frequency 30MHz~1GHz

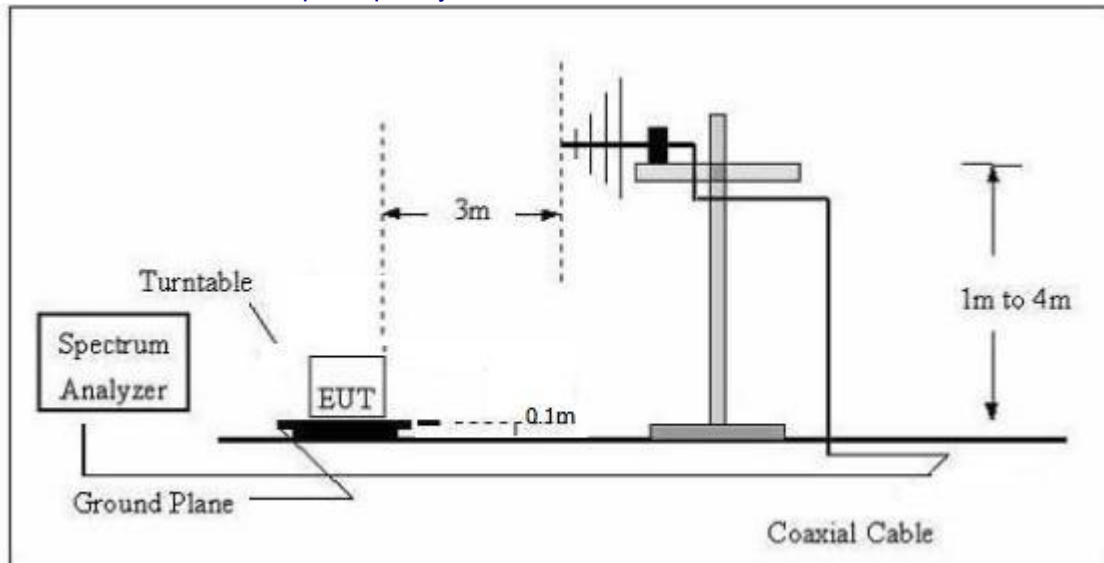

(C) Radiated Emission Test-Up Frequency Above 1GHz

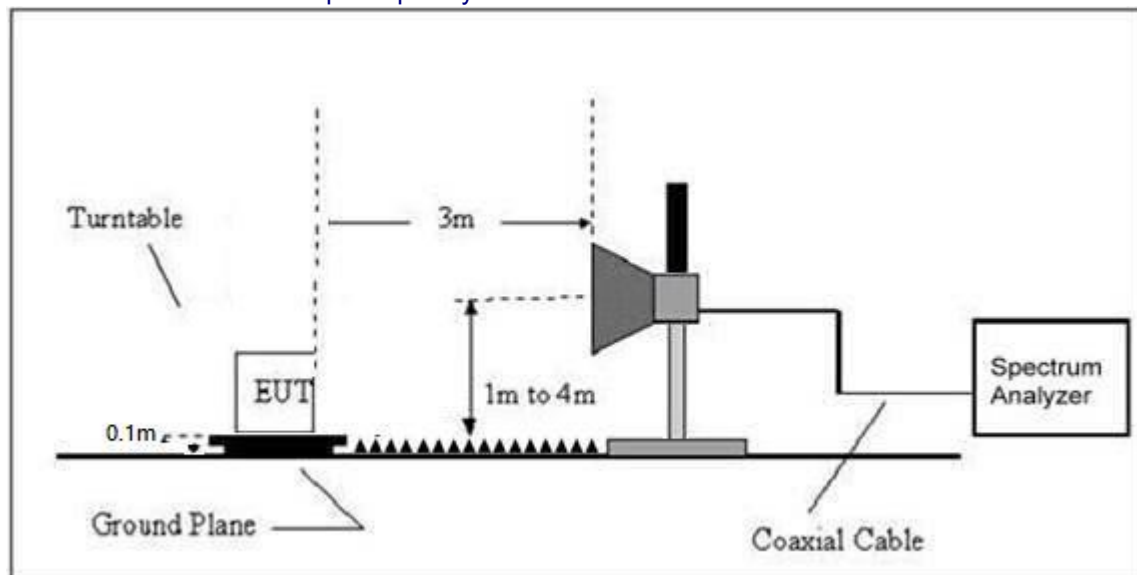

4.2.5 EUT OPERATING CONDITIONS

The EUT tested system was configured as the statements of 2.4 Unless otherwise a special operating condition is specified in the follows during the testing.

4.2.6 TEST RESULTS

Field Strength of Fundamental:

ANT1					
Frequency (MHz)	Emission (dBuV/m)	PK/AV	Ant. Pol.	Limits PK/AV (dBuV/m)	Margin (dB)
2403	110.98	Peak	H	114	-3.02
2403	89.65	AV	H	94	-4.35
2403	108.41	Peak	V	114	-5.59
2403	86.84	AV	V	94	-7.16

ANT1					
Frequency (MHz)	Emission (dBuV/m)	PK/AV	Ant. Pol.	Limits PK/AV (dBuV/m)	Margin (dB)
2432	104.14	Peak	H	114	-9.86
2432	85.65	AV	H	94	-8.35
2432	107.57	Peak	V	114	-6.43
2432	86.54	AV	V	94	-7.46

ANT1					
Frequency (MHz)	Emission (dBuV/m)	PK/AV	Ant. Pol.	Limits PK/AV (dBuV/m)	Margin (dB)
2478	110.47	Peak	H	114	-3.53
2478	90.97	AV	H	94	-3.03
2478	109.57	Peak	V	114	-4.43
2478	85.54	AV	V	94	-8.46

ANT2					
Frequency (MHz)	Emission (dBuV/m)	PK/AV	Ant. Pol.	Limits PK/AV (dBuV/m)	Margin (dB)
2403	109.36	Peak	H	114	-4.64
2403	89.57	AV	H	94	-4.43
2403	106.68	Peak	V	114	-7.32
2403	91.35	AV	V	94	-2.65

ANT2					
Frequency (MHz)	Emission (dBuV/m)	PK/AV	Ant. Pol.	Limits PK/AV (dBuV/m)	Margin (dB)
2432	110.57	Peak	H	114	-3.43
2432	86.98	AV	H	94	-7.02

2432	109.57	Peak	V	114	-4.43
2432	88.24	AV	V	94	-5.76

ANT2					
Frequency (MHz)	Emission (dBuV/m)	PK/AV	Ant. Pol.	Limits PK/AV (dBuV/m)	Margin (dB)
2478	107.47	Peak	H	114	-6.53
2478	88.67	AV	H	94	-5.33
2478	109.51	Peak	V	114	-4.49
2478	89.74	AV	V	94	-4.26

Spurious Emissions:

For 9 kHz-30MHz Test Results:

The emission from 9 kHz to 30MHz was pre-tested and found the result was 20dB lower than the limit, and according to 15.31(o) & RSS-Gen 6.13, the test result no need to reported.

Between 30MHz – 1GHz

Temperature:	26°C	Relative Humidity:	54%
Pressure:	101 kPa	Polarization:	Horizontal
Test Voltage:	DC 53.2V/28A	worst mode:	ANT2-low channel

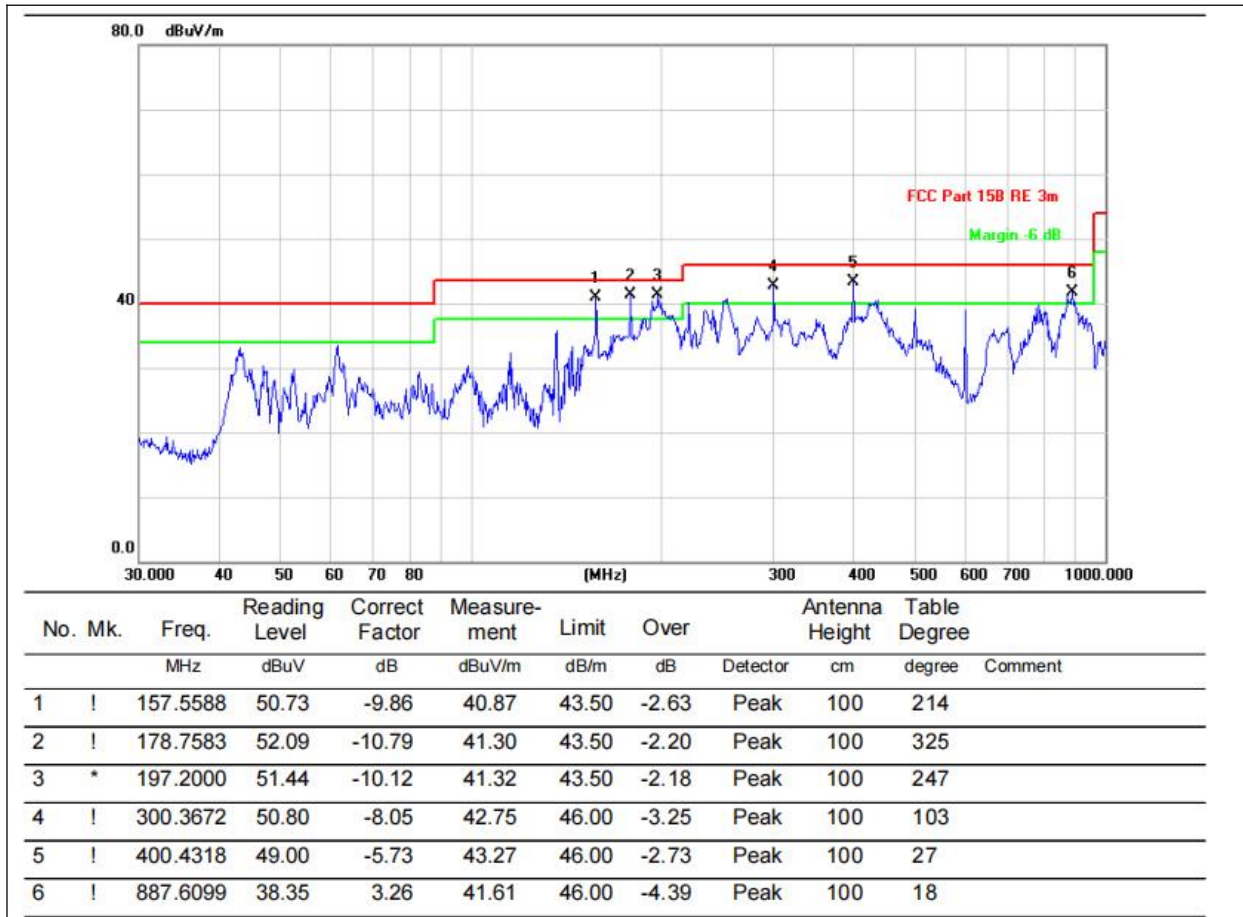

Temperature:	26°C	Relative Humidity:	54%
Pressure:	101kPa	Polarization:	Vertical
Test Voltage:	DC 53.2V/28A	worst mode:	ANT2-low channel

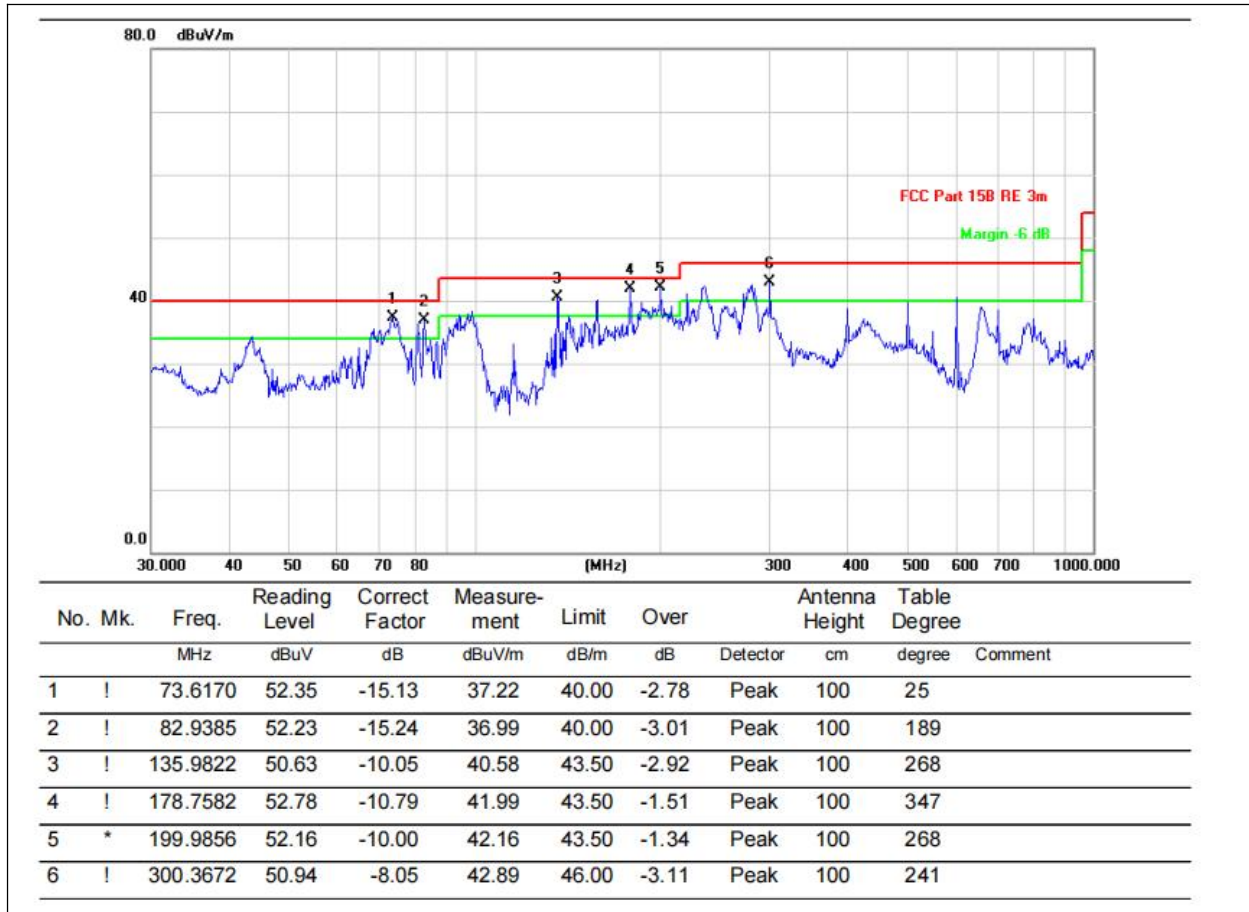

Remarks:

1. Final Level = Receiver Read level + Antenna Factor + Cable Loss – Preamplifier Factor
2. The emission levels of other frequencies are very lower than the limit and not show in test report.
3. The test data shows only the worst case

1GHz~25GHz

Polar (H/V)	Frequency	Meter Reading	Pre-ampli fier	Cable Loss	Antenna Factor	Emission Level	Limits	Margin	Detector Type
	(MHz)	(dBuV)	(dB)	(dB)	(dB)	(dBuV/m)	(dBuV/m)	(dB)	
Low Channel: 2403MHz--ANT1									
V	4806.00	54.04	30.55	5.77	24.66	53.92	74.00	-20.08	Pk
V	4806.00	39.95	30.55	5.77	24.66	39.83	54.00	-14.17	AV
V	7209.00	54.45	30.33	6.32	24.55	54.99	74.00	-19.01	Pk
V	7209.00	41.65	30.33	6.32	24.55	42.19	54.00	-11.81	AV
V	9612.00	51.90	30.85	7.45	24.69	53.19	74.00	-20.81	Pk
V	9612.00	38.89	30.85	7.45	24.69	40.18	54.00	-13.82	AV
H	4806.00	53.85	30.55	5.77	24.66	53.73	74.00	-20.27	Pk
H	4806.00	40.44	30.55	5.77	24.66	40.32	54.00	-13.68	AV
H	7209.00	53.74	30.33	6.32	24.55	54.28	74.00	-19.72	Pk
H	7209.00	39.01	30.33	6.32	24.55	39.55	54.00	-14.45	AV
H	9612.00	52.02	30.85	7.45	24.69	53.31	74.00	-20.69	Pk
H	9612.00	37.99	30.85	7.45	24.69	39.28	54.00	-14.72	AV

Polar (H/V)	Frequency	Meter Reading	Pre-ampli fier	Cable Loss	Antenna Factor	Emission Level	Limits	Margin	Detector Type
	(MHz)	(dBuV)	(dB)	(dB)	(dB)	(dBuV/m)	(dBuV/m)	(dB)	
Middle channel: 2432MHz--ANT1									
V	4864.00	54.34	30.55	5.77	24.66	54.22	74.00	-19.78	Pk
V	4864.00	41.11	30.55	5.77	24.66	40.99	54.00	-13.01	AV
V	7296.00	53.42	30.33	6.32	24.55	53.96	74.00	-20.04	Pk
V	7296.00	41.25	30.33	6.32	24.55	41.79	54.00	-12.21	AV
V	9728.00	50.97	30.85	7.45	24.69	52.26	74.00	-21.74	Pk
V	9728.00	37.85	30.85	7.45	24.69	39.14	54.00	-14.86	AV
H	4864.00	54.83	30.55	5.77	24.66	54.71	74.00	-19.29	Pk
H	4864.00	40.01	30.55	5.77	24.66	39.89	54.00	-14.11	AV
H	7296.00	53.41	30.33	6.32	24.55	53.95	74.00	-20.05	Pk
H	7296.00	39.18	30.33	6.32	24.55	39.72	54.00	-14.28	AV
H	9728.00	52.47	30.85	7.45	24.69	53.76	74.00	-20.24	Pk
H	9728.00	36.79	30.85	7.45	24.69	38.08	54.00	-15.92	AV

Polar (H/V)	Frequency	Meter Reading	Pre-ampli fier	Cable Loss	Antenna Factor	Emission Level	Limits	Margin	Detector Type
	(MHz)	(dBuV)	(dB)	(dB)	(dB)	(dBuV/m)	(dBuV/m)	(dB)	
High Channel: 2478MHz--ANT1									
V	4956.00	53.96	30.55	5.77	24.66	53.84	74.00	-20.16	Pk
V	4956.00	40.93	30.55	5.77	24.66	40.81	54.00	-13.19	AV
V	7434.00	53.89	30.33	6.32	24.55	54.43	74.00	-19.57	Pk
V	7434.00	41.39	30.33	6.32	24.55	41.93	54.00	-12.07	AV
V	9912.00	51.85	30.85	7.45	24.69	53.14	74.00	-20.86	Pk
V	9912.00	39.16	30.85	7.45	24.69	40.45	54.00	-13.55	AV
H	4956.00	55.09	30.55	5.77	24.66	54.97	74.00	-19.03	Pk
H	4956.00	41.44	30.55	5.77	24.66	41.32	54.00	-12.68	AV
H	7434.00	53.16	30.33	6.32	24.55	53.70	74.00	-20.30	Pk
H	7434.00	39.31	30.33	6.32	24.55	39.85	54.00	-14.15	AV
H	9912.00	50.44	30.85	7.45	24.69	51.73	74.00	-22.27	Pk
H	9912.00	36.87	30.85	7.45	24.69	38.16	54.00	-15.84	AV

Polar (H/V)	Frequency	Meter Reading	Pre-ampli fier	Cable Loss	Antenna Factor	Emission Level	Limits	Margin	Detector Type
	(MHz)	(dBuV)	(dB)	(dB)	(dB)	(dBuV/m)	(dBuV/m)	(dB)	
Low Channel: 2403MHz--ANT2									
V	4806.00	54.11	30.55	5.77	24.66	53.99	74.00	-20.01	Pk
V	4806.00	40.43	30.55	5.77	24.66	40.31	54.00	-13.69	AV
V	7209.00	54.69	30.33	6.32	24.55	55.23	74.00	-18.77	Pk
V	7209.00	39.97	30.33	6.32	24.55	40.51	54.00	-13.49	AV
V	9612.00	52.75	30.85	7.45	24.69	54.04	74.00	-19.96	Pk
V	9612.00	36.92	30.85	7.45	24.69	38.21	54.00	-15.79	AV
H	4806.00	56.64	30.55	5.77	24.66	56.52	74.00	-17.48	Pk
H	4806.00	41.04	30.55	5.77	24.66	40.92	54.00	-13.08	AV
H	7209.00	54.50	30.33	6.32	24.55	55.04	74.00	-18.96	Pk
H	7209.00	41.25	30.33	6.32	24.55	41.79	54.00	-12.21	AV
H	9612.00	51.83	30.85	7.45	24.69	53.12	74.00	-20.88	Pk
H	9612.00	36.71	30.85	7.45	24.69	38.00	54.00	-16.00	AV

Polar (H/V)	Frequency	Meter Reading	Pre-ampli fier	Cable Loss	Antenna Factor	Emission Level	Limits	Margin	Detector Type
	(MHz)	(dBuV)	(dB)	(dB)	(dB)	(dBuV/m)	(dBuV/m)	(dB)	
Middle channel: 2432MHz--ANT2									
V	4864.00	55.44	30.55	5.77	24.66	55.32	74.00	-18.68	Pk
V	4864.00	41.63	30.55	5.77	24.66	41.51	54.00	-12.49	AV
V	7296.00	54.10	30.33	6.32	24.55	54.64	74.00	-19.36	Pk
V	7296.00	39.45	30.33	6.32	24.55	39.99	54.00	-14.01	AV
V	9728.00	52.36	30.85	7.45	24.69	53.65	74.00	-20.35	Pk
V	9728.00	36.62	30.85	7.45	24.69	37.91	54.00	-16.09	AV
H	4864.00	56.62	30.55	5.77	24.66	56.50	74.00	-17.50	Pk
H	4864.00	41.94	30.55	5.77	24.66	41.82	54.00	-12.18	AV
H	7296.00	54.24	30.33	6.32	24.55	54.78	74.00	-19.22	Pk
H	7296.00	40.81	30.33	6.32	24.55	41.35	54.00	-12.65	AV
H	9728.00	52.65	30.85	7.45	24.69	53.94	74.00	-20.06	Pk
H	9728.00	37.69	30.85	7.45	24.69	38.98	54.00	-15.02	AV

Polar (H/V)	Frequency	Meter Reading	Pre-ampli fier	Cable Loss	Antenna Factor	Emission Level	Limits	Margin	Detector Type
	(MHz)	(dBuV)	(dB)	(dB)	(dB)	(dBuV/m)	(dBuV/m)	(dB)	
High Channel: 2478MHz--ANT2									
V	4956.00	55.58	30.55	5.77	24.66	55.46	74.00	-18.54	Pk
V	4956.00	41.82	30.55	5.77	24.66	41.70	54.00	-12.30	AV
V	7434.00	52.93	30.33	6.32	24.55	53.47	74.00	-20.53	Pk
V	7434.00	40.13	30.33	6.32	24.55	40.67	54.00	-13.33	AV
V	9912.00	51.70	30.85	7.45	24.69	52.99	74.00	-21.01	Pk
V	9912.00	36.35	30.85	7.45	24.69	37.64	54.00	-16.36	AV
H	4956.00	54.53	30.55	5.77	24.66	54.41	74.00	-19.59	Pk
H	4956.00	40.16	30.55	5.77	24.66	40.04	54.00	-13.96	AV
H	7434.00	54.75	30.33	6.32	24.55	55.29	74.00	-18.71	Pk
H	7434.00	39.19	30.33	6.32	24.55	39.73	54.00	-14.27	AV
H	9912.00	52.69	30.85	7.45	24.69	53.98	74.00	-20.02	Pk
H	9912.00	36.61	30.85	7.45	24.69	37.90	54.00	-16.10	AV

Remark:

1. Emission Level = Meter Reading + Antenna Factor + Cable Loss – Pre-amplifier,
Margin= Emission Level - Limit
2. If peak below the average limit, the average emission was no test.
3. The amplitude of spurious emissions which are attenuated by more than 20dB below the permissible value has no need to be reported.

5. BAND EDGE

5.1 TEST REQUIREMENT:

Test Requirement:	FCC Part15 C Section 15.249&15.209				
Test Method:	ANSI C63.10: 2013				
Test Frequency Range:	All of the restrict bands were tested, only the worst band's (902MHz to 928MHz) data was showed.				
Test site:	Measurement Distance: 3m				
Receiver setup:	Frequency	Detector	RBW	VBW	Value
	9KHz-150KHz	Quasi-peak	200Hz	600Hz	Quasi-peak
	150KHz-30MHz	Quasi-peak	9KHz	30KHz	Quasi-peak
	30MHz-1GHz	Quasi-peak	120KHz	300KHz	Quasi-peak

Emissions radiated outside of the specified frequency bands, except for harmonics, shall be attenuated by at least 50 dB below the level of the fundamental or to the general radiated emission limits in § 15.209, whichever is the lesser attenuation

5.2 TEST PROCEDURE

Below 1GHz test procedure as below:

- The EUT was placed on the top of a rotating table 0.1 meters above the ground at a 3 meter semi-anechoiccamber. The table was rotated 360 degrees to determine the position of the highest radiation.
- The EUT was set 3 meters away from the interference-receiving antenna, which was mounted on the top of avariable-height antenna tower.
- The antenna height is varied from one meter to four meters above the ground to determine the maximum valueof the field strength. Both horizontal and vertical polarizations of the antenna are set to make the measurement.
- For each suspected emission, the EUT was arranged to its worst case and then the antenna was tuned toheights from 1 meter to 4 meters (for the test frequency of below 30MHz, the antenna was tuned to heights 1meter) and the rotatable table was turned from 0 degrees to 360 degrees to find the maximum reading.
- The test-receiver system was set to Peak Detect Function and Specified Bandwidth with Maximum Hold Mode.
- If the emission level of the EUT in peak mode was 10dB lower than the limit specified, then testing could bestopped and the peak values of the EUT would be reported. Otherwise the emissions that did not have 10dBmargin would be re-tested one by one using peak, quasi-peak or average method as specified and then reportedin a data sheet.

5.3 DEVIATION FROM TEST STANDARD

No deviation

5.4 TEST SETUP

Radiated Emission Test-Up Frequency 30MHz~1GHz

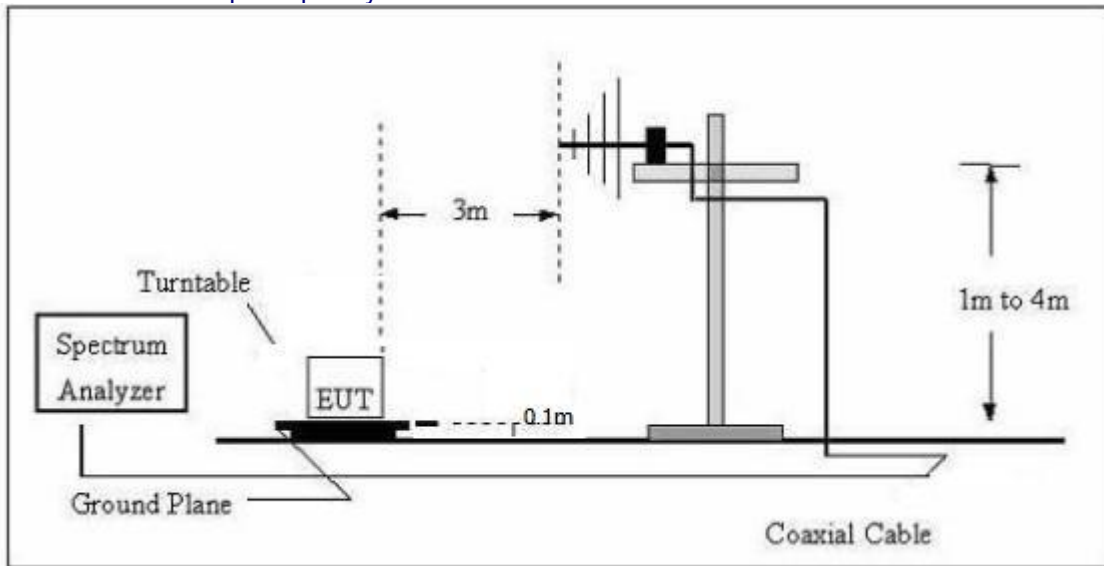

5.5 EUT OPERATING CONDITIONS

The EUT tested system was configured as the statements of 2.3 Unless otherwise a special operating condition is specified in the follows during the testing.

5.6 TEST RESULT

	Polar (H/V)	Frequency (MHz)	Meter Reading (dBuV)	Pre-amplifier (dB)	Cable Loss (dB)	Antenna Factor (dB/m)	Emission level (dBuV/m)	Limit (dBuV/m)	Margin	Detector Type	Result	
Low Channel: 2403MHz--ANT1												
FSK	H	2390	54.55	30.22	4.85	23.98	53.16	74	-20.84	PK	PASS	
	H	2390	38.21	30.22	4.85	23.98	36.82	54	-17.18	AV	PASS	
	H	2400	54.22	30.22	4.85	23.98	52.83	74	-21.17	PK	PASS	
	H	2400	40.18	30.22	4.85	23.98	38.79	54	-15.21	AV	PASS	
	V	2390	52.81	30.22	4.85	23.98	51.42	74	-22.58	PK	PASS	
	V	2390	42.71	30.22	4.85	23.98	41.32	54	-12.68	AV	PASS	
	V	2400	53.66	30.22	4.85	23.98	52.27	74	-21.73	PK	PASS	
	V	2400	37.97	30.22	4.85	23.98	36.58	54	-17.42	AV	PASS	
	High Channel: 2478MHz--ANT1											
	H	2483.5	47.32	30.22	4.85	23.98	45.93	74	-28.07	PK	PASS	
	H	2483.5	38.73	30.22	4.85	23.98	37.34	54	-16.66	AV	PASS	
	H	2500	54.52	30.22	4.85	23.98	53.13	74	-20.87	PK	PASS	
	H	2500	36.11	30.22	4.85	23.98	34.72	54	-19.28	AV	PASS	
	V	2483.5	57.66	30.22	4.85	23.98	56.27	74	-17.73	PK	PASS	
V	2483.5	41.68	30.22	4.85	23.98	40.29	54	-13.71	AV	PASS		
V	2500	53.26	30.22	4.85	23.98	51.87	74	-22.13	PK	PASS		
V	2500	41.09	30.22	4.85	23.98	39.70	54	-14.30	AV	PASS		

Remark:

1. Emission Level = Meter Reading + Antenna Factor + Cable Loss – Pre-amplifier, Margin= Emission Level - Limit

	Polar (H/V)	Frequency (MHz)	Meter Reading (dBuV)	Pre-amplifier (dB)	Cable Loss (dB)	Antenna Factor (dB/m)	Emission level (dBuV/m)	Limit (dBuV/m)	Margin	Detector Type	Result
Low Channel: 2403MHz--ANT2											
FSK	H	2390	55.62	30.22	4.85	23.98	54.23	74	-19.77	PK	PASS
	H	2390	36.86	30.22	4.85	23.98	35.47	54	-18.53	AV	PASS

H	2400	52.36	30.22	4.85	23.98	50.97	74	-23.03	PK	PASS
H	2400	40.65	30.22	4.85	23.98	39.26	54	-14.74	AV	PASS
V	2390	51.14	30.22	4.85	23.98	49.75	74	-24.25	PK	PASS
V	2390	41.14	30.22	4.85	23.98	39.75	54	-14.25	AV	PASS
V	2400	51.39	30.22	4.85	23.98	50.00	74	-24.00	PK	PASS
V	2400	39.28	30.22	4.85	23.98	37.89	54	-16.11	AV	PASS
High Channel: 2478MHz--ANT2										
H	2483.5	50.28	30.22	4.85	23.98	48.89	74	-25.11	PK	PASS
H	2483.5	35.08	30.22	4.85	23.98	33.69	54	-20.31	AV	PASS
H	2500	54.66	30.22	4.85	23.98	53.27	74	-20.73	PK	PASS
H	2500	39.82	30.22	4.85	23.98	38.43	54	-15.57	AV	PASS
V	2483.5	58.23	30.22	4.85	23.98	56.84	74	-17.16	PK	PASS
V	2483.5	43.38	30.22	4.85	23.98	41.99	54	-12.01	AV	PASS
V	2500	57.57	30.22	4.85	23.98	56.18	74	-17.82	PK	PASS
V	2500	43.30	30.22	4.85	23.98	41.91	54	-12.09	AV	PASS

Remark:

1. Emission Level = Meter Reading + Antenna Factor + Cable Loss – Pre-amplifier, Margin= Emission Level - Limit

Remark:

1. Emission Level = Meter Reading + Antenna Factor + Cable Loss – Pre-amplifier, Margin= Emission Level - Limit

6. CHANNEL BANDWIDTH

Test Requirement:	FCC Part15 C Section 15.215(c)
Test Method:	ANSI C63.10: 2013

6.1 APPLIED PROCEDURES / LIMIT

Section	Test Item	Frequency Range (MHz)	Result
15.215(c)	Bandwidth	2400-2483.5	PASS

6.2 TEST PROCEDURE

1. Set resolution bandwidth (RBW) =1% to 5% of the OBW,
2. Set the video bandwidth (VBW) $\geq 3 \times$ RBW.
3. Detector = Peak.
4. Trace mode = max hold.
5. Sweep = auto couple.
6. Allow the trace to stabilize.
7. Measure the maximum width of the emission that is constrained by the frequencies associated with the two outermost amplitude points (upper and lower) that are attenuated by 6 dB relative to the maximum level measured in the fundamental emission.

6.3 DEVIATION FROM STANDARD

No deviation.

6.4 TEST SETUP



6.5 EUT OPERATION CONDITIONS

The EUT tested system was configured as the statements of 2.4 Unless otherwise a special operating condition is specified in the follows during the testing.

6.6 TEST RESULTS

Temperature :	26°C	Relative Humidity :	54%
Test Mode :	FSK	Test Voltage :	AC120V

Test channel	20dB bandwidth (MHz)		Result
	ANT1	ANT2	
Lowest	1.382	1.377	Pass
middle	1.381	1.382	
Highest	1.382	1.383	

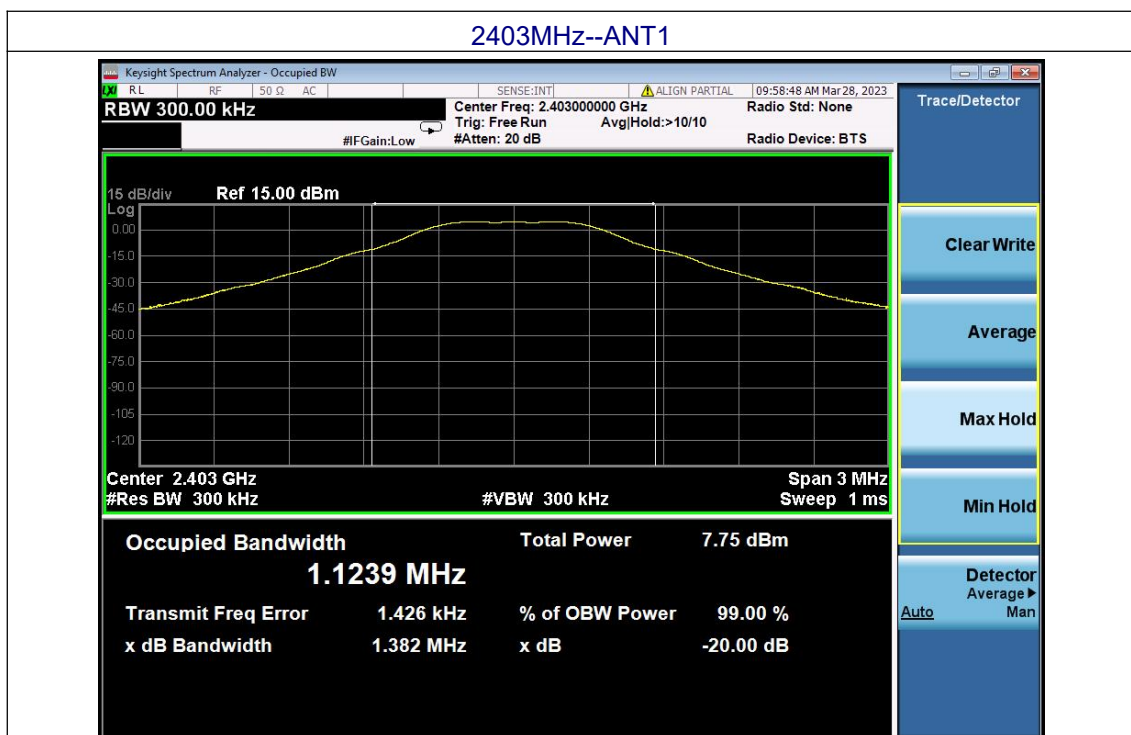

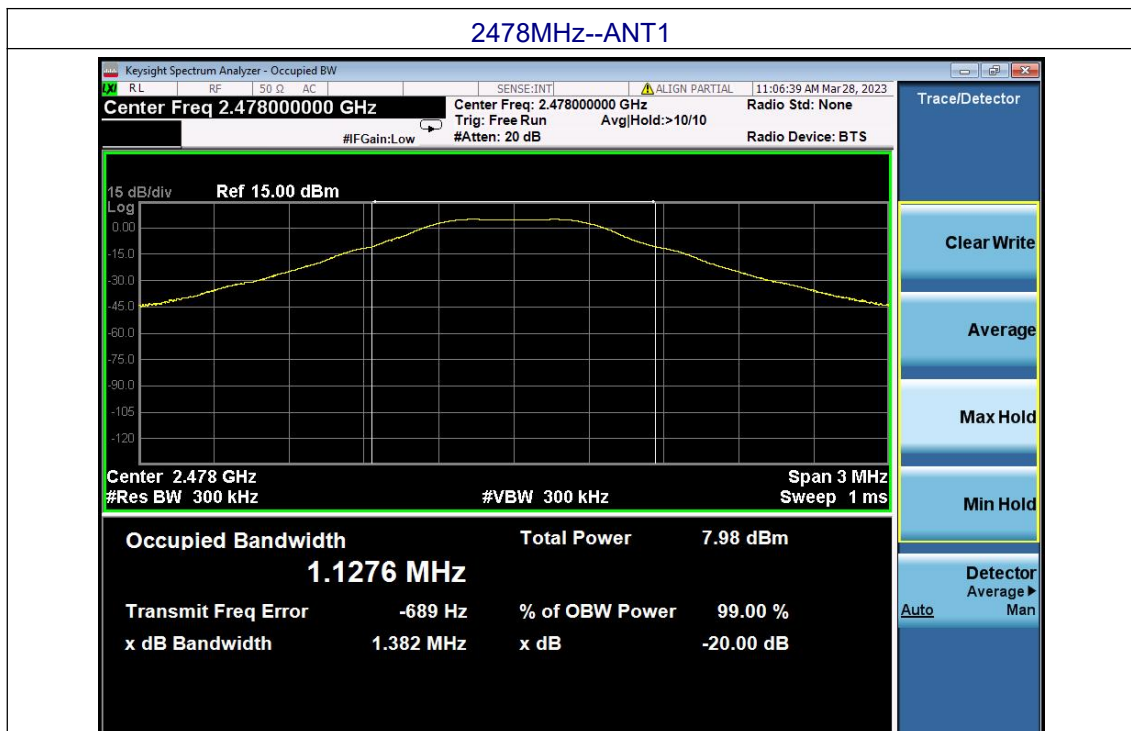
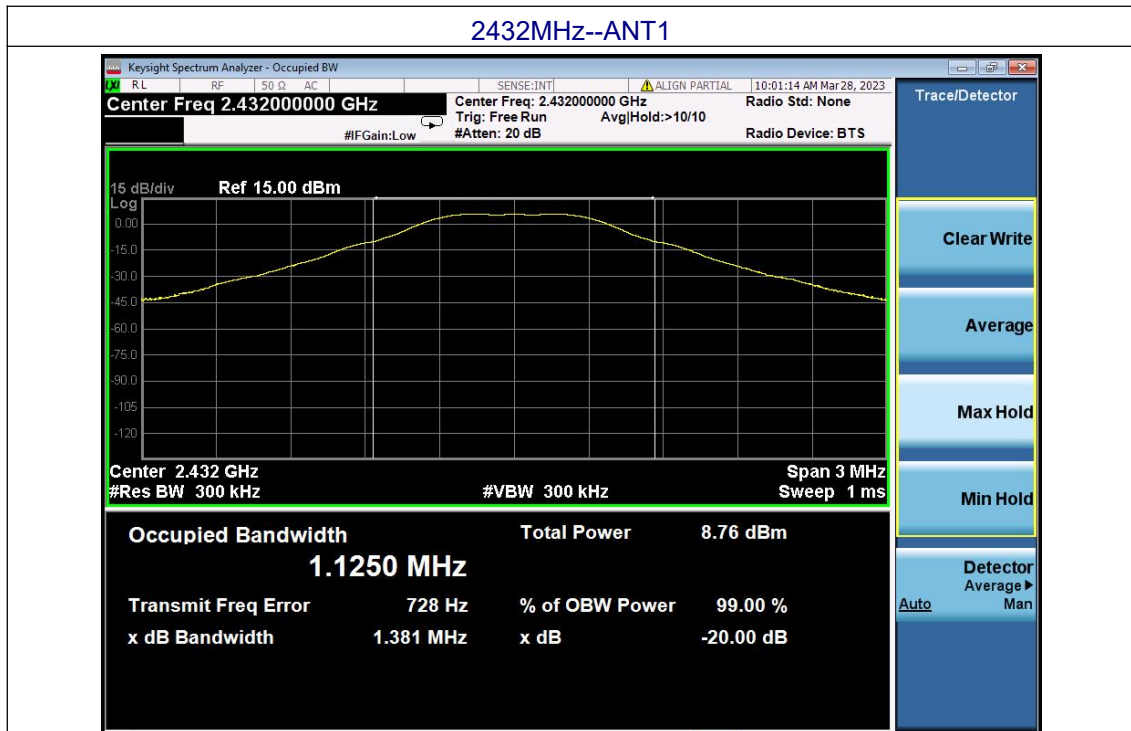

2403MHz--ANT2

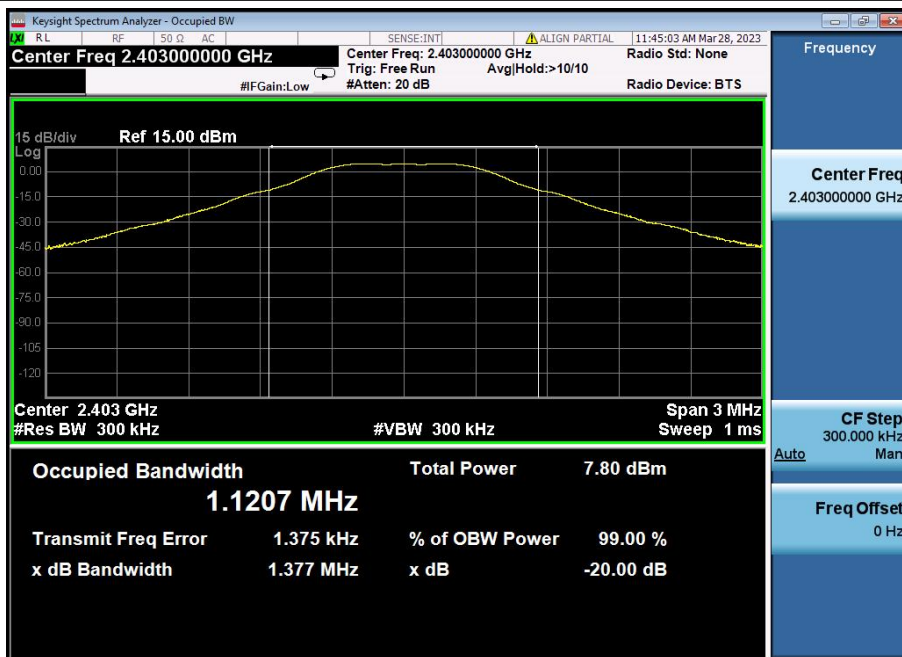

2432MHz--ANT2

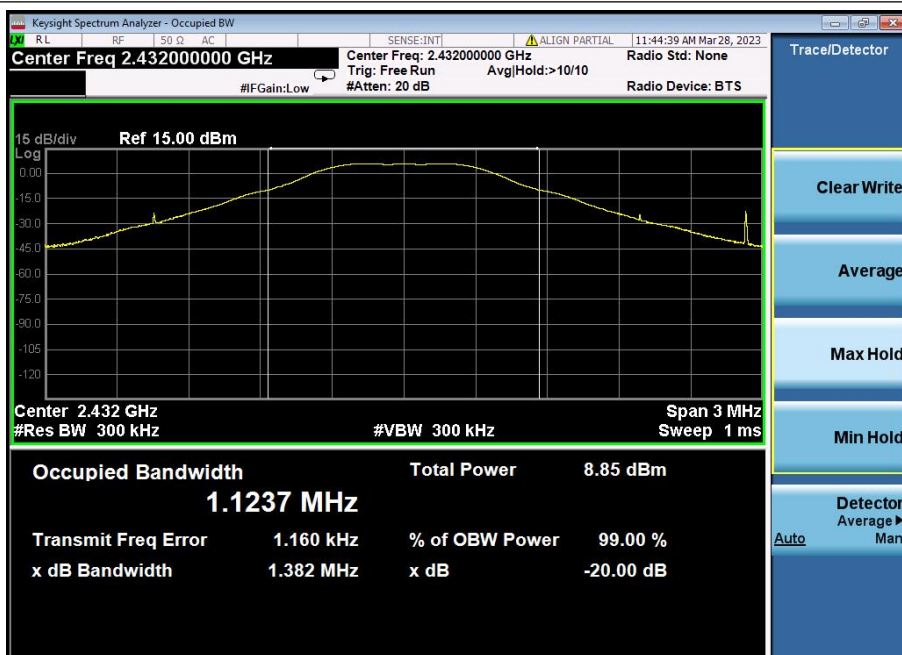

7. ANTENNA REQUIREMENT

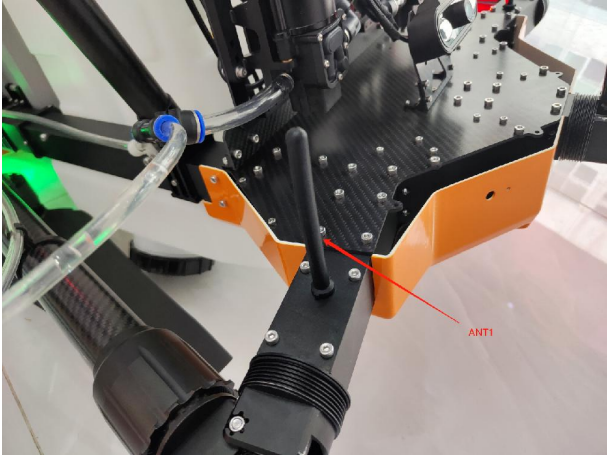
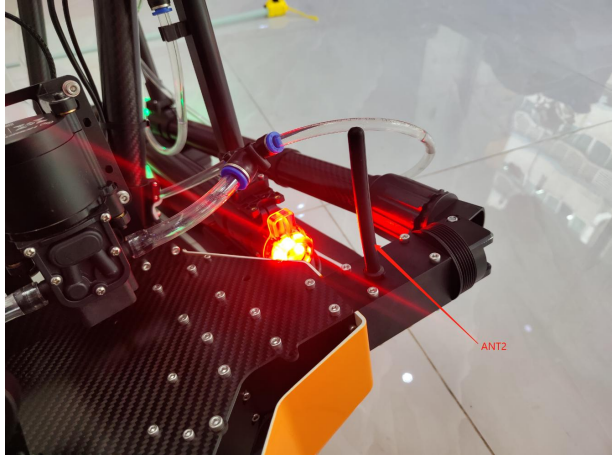
Standard requirement:	FCC Part15 C Section 15.203
<p>15.203 requirement: An intentional radiator shall be designed to ensure that no antenna other than that furnished by the responsible party shall be used with the device. The use of a permanently attached antenna or of an antenna that uses a unique coupling to the intentional radiator, the manufacturer may design the unit so that a broken antenna can be replaced by the user, but the use of a standard antenna jack or electrical connector is prohibited.</p>	
<p>EUT Antenna:</p>	
<p>The antennas is External antenna, the best case gain of the antenna is 2dBi Max, reference to the internal photos</p>	
	

8. TEST SETUP PHOTO

Reference to the Test setup file for details.

9. EUT CONSTRUCTIONAL DETAILS

Reference to the external photos file and internal photos file for details.

******* END OF REPORT *******