



FCC/ IC TEST REPORT

According to

CFR47 §15.247/RSS-247 Issue 2

Applicant : JS Products,Inc.
Address : 6445 Montessouri Street Las Vegas, NV 89113
Manufacturer : Ningbo Aston Optoelectronic Technology Co.,Ltd
Address : Zhouhan Village Industry Zone,Yinzhou District,Ningbo,315195,P.R.of China
Equipment : Bluetooth® Speaker Charger
Model No. : TL60096
FCC ID : 2AN8HTL60096
IC : 23363-TL60096
Test Period : Nov.23,2017~ Nov.25, 2017

- The test result refers exclusively to the test presented test model / sample.
- Without written approval of **Cerpass Technology Corporation Test Laboratory**, the test report shall not be reproduced except in full.
- The test report must not be used by the clients to claim product certification approval by any agency of the Government.

I HEREBY CERTIFY THAT :

The measurements shown in this test report were made in accordance with the procedures given in **ANSI C63.10 – 2013&RSS-247,Issue 2&RSS-Gen issue 5&FCC Part15.247**and the energy emitted by this equipment was **passed**.

Approved by:

Laboratory Accreditation:

Mark Liao / Assistant Manager



Cerpass Technology Corporation Test Laboratory

TAF LAB Code:	1439
----------------------	-------------



Contents

1. Report of Measurements and Examinations	5
2. General Info.....	6
2.1 Description of EUT.....	6
2.2 Description of wireless module	6
2.3 Description of Antenna.....	6
2.4 Carrier Frequency of Channels.....	7
2.5 The Worst Case Configuration.....	8
2.6 EUT Exercise Software.....	8
2.7 Support equipment.....	9
3. General Information of Test Site	10
3.1 Information of Test Site	10
3.2 Measuring Equipment.....	11
3.3 Measurement Uncertainty.....	12
4. AC Conducted Emission Measurement	14
4.1 Test Limit.....	14
4.2 Test Procedures	14
4.3 Typical Test Setup.....	14
4.4 Test Result and Data.....	15
5. Radiated Emission Measurement	17
5.1 Test Limit.....	17
5.2 Test Standard	18
5.3 Test Procedures.....	18
5.4 Typical Test Setup	18
5.5 Test Result and Data.....	20
6. 20dB Bandwidth Measurement	27
6.1 Test Limit.....	27
6.2 Test Standard	27
6.3 Test Setup	27
6.4 Test Setup Layout	27
6.5 Test Result and Data.....	28
7. Channel Carrier Frequencies Separation Measurement	31
7.1 Test Limit.....	31
7.2 Test Standard	31
7.3 Test Setup	31
7.4 Test Setup Layout	31
7.5 Test Result and Data.....	32
8. Dwell Time Measurement.....	35
8.1 Test Limit.....	35
8.2 Test Standard	35
8.3 Test Setup	35
8.4 Test Setup Layout	35
8.5 Test Result and Data.....	36
9. Number of Hopping Channels Measurement	39



9.1 Test Limit 39

9.2 Test Standard 39

9.3 Test Setup 39

9.4 Test Setup Layout 39

9.5 Test Result and Data 40

10. Peak Output Power Measurement 43

10.1 Test Limit 43

10.2 Test Standard 43

10.3 Test Setup 43

10.4 Test Setup Layout 43

10.5 Test Result and Data 44

11. Conducted Spurious Emissions Measurement 46

11.1 Limit 46

11.2 Test Procedure 47

11.3 Test Setup 47

11.4 Test Result 48

12. Radiated Emission Band Edge Measurement 56

12.1 Limit 56

12.2 Test Procedure 56

12.3 Test Setup 57

12.4 Test Result 58



History of this Test Report

Report No.	Version	Issue Date	Description
TEF1711208	Rev 01	Nov.30, 2017	Original.
TEF1711208	Rev 02	Mar.09, 2018	Add EIRP Power datas
TEF1711208	Rev 03	May.24, 2018	Add the version of RSS GEN



1. Report of Measurements and Examinations

	Reference STD	Description of Test	Compliance results
1	FCC Rules §15.207(a); RSS-GEN issue 5 Section 8.8	AC Conducted Emission	PASS
2	FCC Rules §15.209(a); RSS-247 Issue 2 Section 5.5 RSS-Gen Issue 5 April 2018 Section 6.13	Radiated Emission	PASS
3	FCC Rules §15.247(a)(1); RSS-247 Issue 2 Section5.1(a)	20dB Bandwidth	PASS
4	FCC Rules §15.247(a)(1); RSS-247 Issue 2 Section5.1(b)	Channel Carrier Frequencies Separation	PASS
5	FCC Rules§15.247(a)(1); RSS-247 Issue 2 Section5.1(c)	Dwell Time	PASS
6	FCC Rules§15.247(b); RSS-247 Issue 2 Section5.1(b)	Number of Hopping Channels	PASS
7	FCC Rules §15.247(b); RSS-247 Issue 2 Section5.1(b)	Peak Output Power	PASS
8	FCC Rules §15.247(d)	Band-edge Compliance & Conducted Spurious Emissions	PASS
9	FCC Rules §15.247(d); RSS-247 Issue 2 Section 5.5	Radiated Emission Band Edges	PASS



2. General Info

2.1 Description of EUT

Product name	Bluetooth® Speaker Charger	
Model No.	TL60096	
Operational Climate	Tnomal:	25°C
	Tmin:	-10°C
	Tmax:	70°C
Power supply	Model:	K25V120150U
	Input:	100-240V~ 50/60Hz 0.6A
	Output:	12V $\overline{\text{---}}$ 1.5A

2.2 Description of wireless module

Module Name	JS-BTMJ2F89
Bluetooth Specification	EDR
Modulation Type	GFSK, $\pi/4$ DQPSK,8DPSK
Frequency Range	2402 - 2480 MHz
Channel Number	79
Data Rate	1Mbps(GFSK), 2Mbps($\pi/4$ DQPSK), 3Mbps (8DPSK)
Channel Separation	1MHz

Note: For more details, please refer to the EUT User manual.

2.3 Description of Antenna

Antenna Type	Peak Gain
PCB	0.5dBi for 2402 - 2480 MHz



2.4 Carrier Frequency of Channels

Bluetooth Working Frequency of Each Channel:							
Channel	Frequency	Channel	Frequency	Channel	Frequency	Channel	Frequency
00	2402 MHz	01	2403 MHz	02	2404 MHz	03	2405 MHz
04	2406 MHz	05	2407 MHz	06	2408 MHz	07	2409 MHz
08	2410 MHz	09	2411 MHz	10	2412 MHz	11	2413 MHz
12	2414 MHz	13	2415 MHz	14	2416 MHz	15	2417 MHz
16	2418 MHz	17	2419 MHz	18	2420 MHz	19	2421 MHz
20	2422 MHz	21	2423 MHz	22	2424 MHz	23	2425 MHz
24	2426 MHz	25	2427 MHz	26	2428 MHz	27	2429 MHz
28	2430 MHz	29	2431 MHz	30	2432 MHz	31	2433 MHz
32	2434 MHz	33	2435 MHz	34	2436 MHz	35	2437 MHz
36	2438 MHz	37	2439 MHz	38	2440 MHz	39	2441 MHz
40	2442 MHz	41	2443 MHz	42	2444 MHz	43	2445 MHz
44	2446 MHz	45	2447 MHz	46	2448 MHz	47	2449 MHz
48	2450 MHz	49	2451 MHz	50	2452 MHz	51	2453 MHz
52	2454 MHz	53	2455 MHz	54	2456 MHz	55	2457 MHz
56	2458 MHz	57	2459 MHz	58	2460 MHz	59	2461 MHz
60	2462 MHz	61	2463 MHz	62	2464 MHz	63	2465 MHz
64	2466 MHz	65	2467 MHz	66	2468 MHz	67	2469 MHz
68	2470 MHz	69	2471 MHz	70	2472 MHz	71	2473 MHz
72	2474 MHz	73	2475 MHz	74	2476 MHz	75	2477 MHz
76	2478 MHz	77	2479 MHz	78	2480 MHz	N/A	N/A



2.5 The Worst Case Configuration

Data rate Configuration:

Modulation Mode	Test Channel	Data Rate	Peak Power(dBm)
GFSK	39	1Mbps(DH1)	-0.46
		1Mbps(DH3)	-0.41
		1Mbps(DH5)	-0.38
$\pi/4$ DQPSK	39	2Mbps(2DH1)	2.76
		2Mbps(2DH3)	2.81
		2Mbps(2DH5)	2.84
8DPSK	39	3Mbps(3DH1)	3.12
		3Mbps(3DH3)	3.17
		3Mbps(3DH5)	3.19

Modulation Mode	Worst Data Rate
GFSK	1Mbps(DH5)
$\pi/4$ DQPSK	2Mbps(2DH5)
8DPSK	3Mbps(3DH5)

Note: 1. Power output test was verified over all data rates of each mode, and then choose the maximum power output for final test of each channel shown as the table.

2. EUT is put X,Y,Z three axial assessment test,and Y axial is the worst case,so the EUT is put Y axial for all RF items tested.

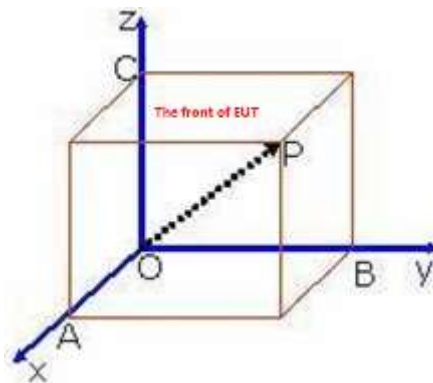

2.6 EUT Exercise Software

1	Turn on the power of equipment.
2	Run 'QRCT', input RF test command and set the test mode and channel, then press Transmit to start continue transmit.



2.7 Support equipment

Product	Manufacturer	Model No.	Serial No.
1	N/A	N/A	N/A

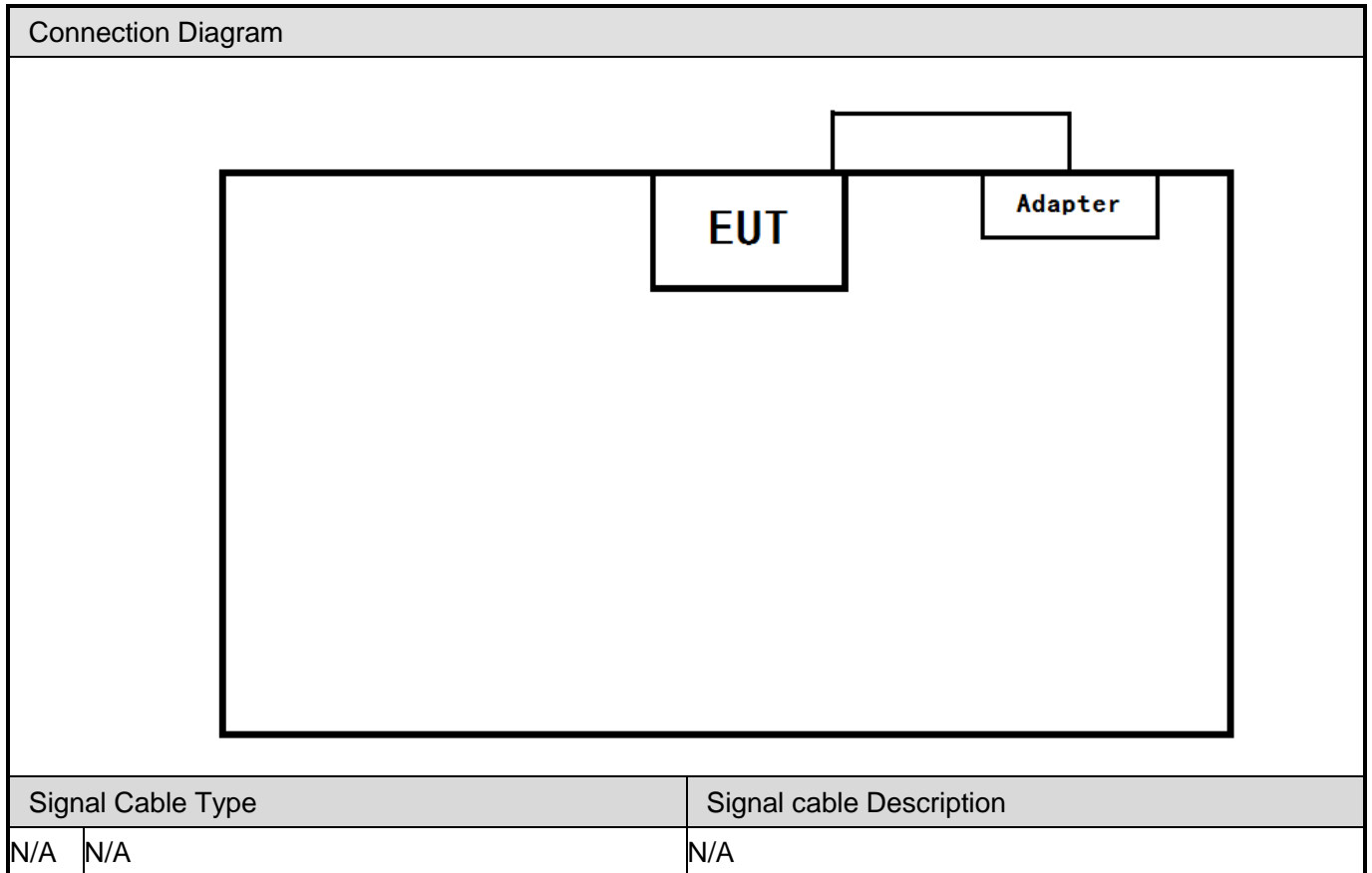



3. General Information of Test Site

3.1 Information of Test Site

Test Site :	Cerpass Technology Corporation Test Laboratory Location: No.10 Lane2 Lianfu Street Luzhu District, Taoyuan City Taiwan ROC <u>Tel:+886-3-3226-888</u> <u>Fax:+886-3-3226-881</u>
FCC Registration Number :	TW1079, TW1061, TW1439
IC Registration Number :	4934E-1, 4934E-2
VCCI	T-2205 for Telecommunication Test C-4663 for Conducted emission test R-4218 for Radiated emission test G-10812 for radiated disturbance above 1GHz



3.2 Measuring Equipment

Instrument/Ancillary	Manufacturer	Model No.	Serial No.	Calibration Date	Valid Date.
EMI Receiver	R&S	ESCI3	100443	2017/03/07	2018/03/06
LISN	Schwarzbeck	NSLK 8127	8127-516	2017/09/12	2018/09/11
LISN	Schwarzbeck	NSLK 8127	8127-740	2017/09/04	2018/09/03
Pulse Limiter	R&S	ESH3-Z2	101933	2017/09/04	2018/09/03
Software	Farad	Ez-EMC	ver.ct3a1	N/A	N/A

Instrument/Ancillary	Manufacturer	Model No.	Serial No.	Calibration Date	Valid Date.
Bilog Antenna	Sunol	JB1	A020514-1	2017/02/13	2018/02/12
Bilog Antenna	Sunol	JB1	A020514-2	2017/03/15	2018/03/14
EMI Receiver	R&S	ESCI3	101402	2017/02/13	2018/02/12
EMI Receiver	R&S	ESCI7	100963	2017/03/06	2018/03/05
Preamplifier	EM Electronics corp.	EM330	60610	2017/02/25	2018/02/24
Preamplifier	EM Electronics corp.	EM330	60611	2017/02/10	2018/02/09
Horn Antenna	Schwarzbeck	BBHA 9120 D	9120D-1785	2017/09/27	2018/09/26
Spectrum Analyzer	R&S	FSP40	100047	2017/02/13	2018/02/12
Preamplifier	EM Electronics corp.	EM01G18G	60700	2017/09/01	2018/08/31
Spectrum Analyzer	KEYSIGHT	N9010A	MY54200207	2017.03.17	2018.03.16
Software	E3	AUDIX	Version: 8.14.806b	N/A	N/A



3.3 Measurement Uncertainty

ISO/IEC 17025 requires that an estimate of the measurement uncertainties associated with the emissions test results be included in the report. The measurement uncertainties given below are based on a 95% confidence level (based on a coverage factor (k=2)).

RF Conducted Measurement

Test Item		Uncertainty	Limit
Radio Frequency		$\pm 8.7 \times 10^{-7}$	$\pm 1 \times 10^{-5}$
RF output power, conducted		$\pm 0.63\text{dB}$	$\pm 1.5\text{dB}$
Power density, conducted		$\pm 1.21\text{dB}$	$\pm 3\text{dB}$
Unwanted emissions, conducted	30-1000MHz	$\pm 0.51\text{dB}$	$\pm 3\text{dB}$
	1-12.75GHz	$\pm 0.67\text{dB}$	$\pm 3\text{dB}$
All emissions, radiated	30-1000MHz	$\pm 2.28\text{dB}$	$\pm 6\text{dB}$
	1-12.75GHz	$\pm 2.59\text{dB}$	$\pm 6\text{dB}$
Temperature		$\pm 0.8^\circ\text{C}$	$\pm 1^\circ\text{C}$
Humidity		$\pm 3\%$	$\pm 5\%$
DC and low frequency voltages		$\pm 3\%$	$\pm 3\%$



AC Conducted Measurement

Measurement	Frequency	Uncertainty
Conducted emissions(LINE)	9KHz-30MHz	+/- 0.7738 dB
Conducted emissions(NEUTRAL)	9KHz-30MHz	+/- 0.7886 dB
Conducted emissions(10Mbps)	150KHz-30MHz	+/- 1.3013dB
Conducted emissions(100Mbps)	150KHz-30MHz	+/- 1.3197 dB
Conducted emissions(1000Mbps)	150KHz-30MHz	+/- 1.2987 dB

Radiated Measurement

Measurement	Polarity	Frequency	Uncertainty
Radiated emissions	Horizontal	below 1GHz	+/- 3.8936 dB
	Vertical	below 1GHz	+/- 3.8928 dB
	Horizontal	above 1GHz	+/- 5.18858dB
	Vertical	above 1GHz	+/- 5.18928 dB



4. AC Conducted Emission Measurement

4.1 Test Limit

Conducted Emissions were measured from 150 kHz to 30 MHz with a bandwidth of 9 KHz on the 120 VAC power and return leads of the EUT according to the methods defined in ANSI C63.10-2013 Section 6.2. The EUT was placed on a nonmetallic stand in a shielded room 0.8 meters above the ground plane as shown in section 6.2.2. The interface cables and equipment positioning were varied within limits of reasonable applications to determine the position produced maximum conducted emissions.

Frequency (MHz)	Quasi Peak (dB μ V)	Average (dB μ V)
0.15 – 0.5	66-56*	56-46*
0.5 – 5.0	56	46
5.0 – 30.0	60	50

*Decreases with the logarithm of the frequency.

4.2 Test Procedures

- The EUT was placed 0.4 meter from the conducting wall of the shielding room was kept at least 80 centimeters from any other grounded conducting surface.
- Connect EUT to the power mains through a line impedance stabilization network (LISN).
- All the support units are connecting to the other LISN.
- The LISN provides 50 ohm coupling impedance for the measuring instrument.
- The FCC states that a 50 ohm, 50 micro-Henry LISN should be used.
- Both sides of AC line were checked for maximum conducted interference.
- The frequency range from 150 kHz to 30 MHz was searched.
- Set the test-receiver system to Peak Detect Function and Specified Bandwidth with Maximum Hold Mode.

4.3 Typical Test Setup

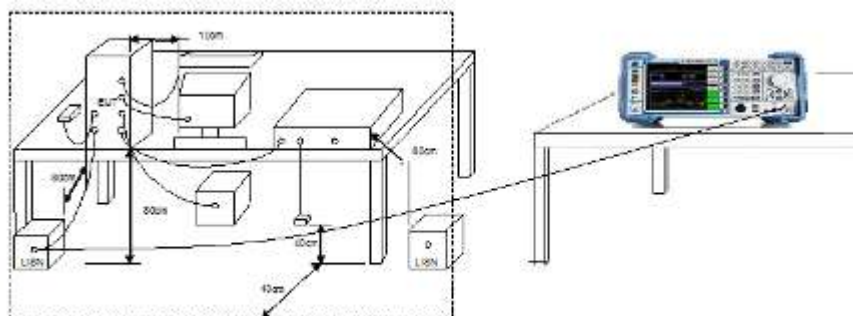



4.4 Test Result and Data

Test Mode :	Mode 1: Normal Operation with BT on		
AC Power :	AC 120V/60Hz	Phase:	LINE
Temperature :	26°C	Humidity:	60%
Pressure(mbar) :	1002	Date:	2017/11/25

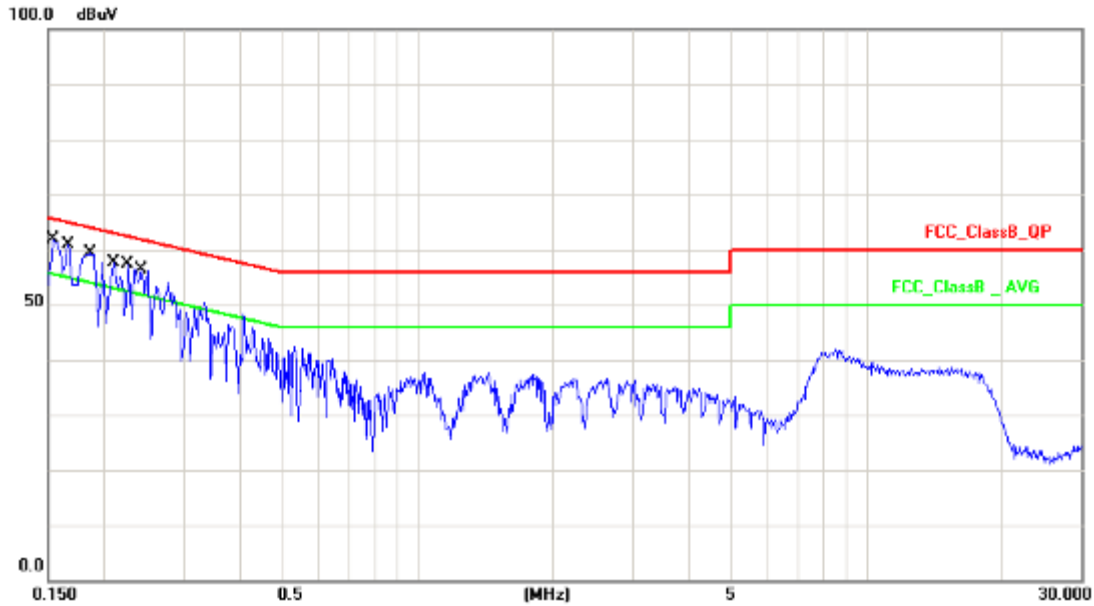

No.	Frequency (MHz)	Factor (dB)	Reading (dBuV)	Level (dBuV)	Limit (dBuV)	Margin (dB)	Detector
1	0.1539	10.13	49.34	59.47	65.78	-6.31	QP
2	0.1539	10.13	30.29	40.42	55.78	-15.36	AVG
3	0.1660	10.13	48.24	58.37	65.15	-6.78	QP
4	0.1660	10.13	28.26	38.39	55.15	-16.76	AVG
5	0.1860	10.12	46.37	56.49	64.21	-7.72	QP
6	0.1860	10.12	28.35	38.47	54.21	-15.74	AVG
7	0.2100	10.12	44.89	55.01	63.20	-8.19	QP
8	0.2100	10.12	26.58	36.70	53.20	-16.50	AVG
9	0.2260	10.12	42.81	52.93	62.59	-9.66	QP
10	0.2260	10.12	24.82	34.94	52.59	-17.65	AVG
11	0.2420	10.12	42.38	52.50	62.02	-9.52	QP
12	0.2420	10.12	23.62	33.74	52.02	-18.28	AVG

Note: Measurement Level = Reading Level + Correct Factor



Test Mode :	Mode 1: Normal Operation with BT on		
AC Power :	AC 120V/60Hz	Phase :	NEUTRAL
Temperature :	26°C	Humidity :	60%
Pressure(mbar) :	1002	Date:	2017/11/25

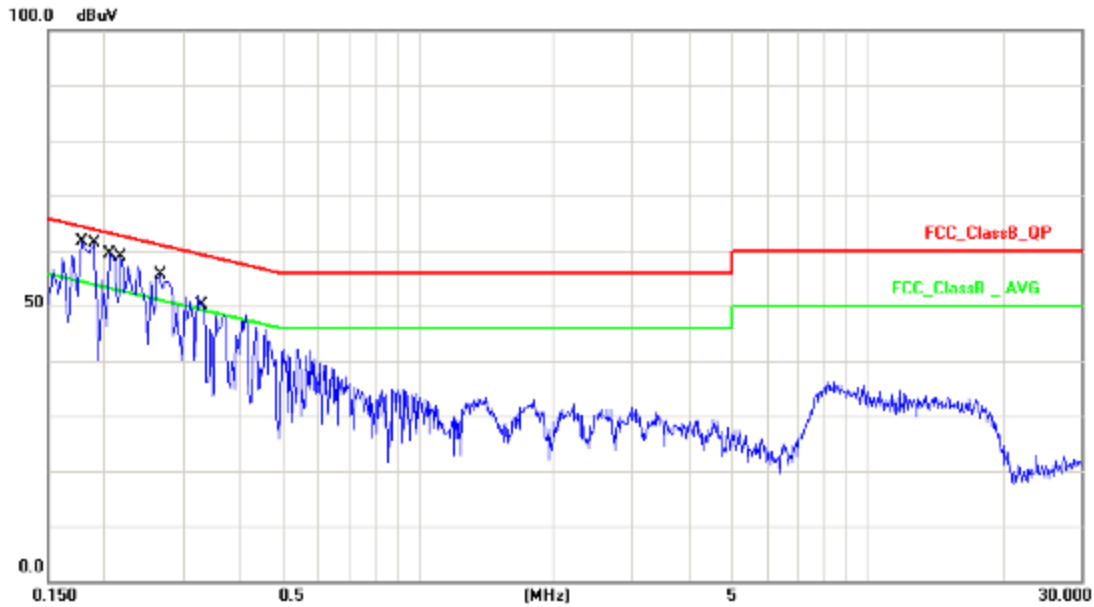

No.	Frequency (MHz)	Factor (dB)	Reading (dBuV)	Level (dBuV)	Limit (dBuV)	Margin (dB)	Detector
1	0.1780	10.13	49.09	59.22	64.57	-5.35	QP
2	0.1780	10.13	28.02	38.15	54.57	-16.42	AVG
3	0.1900	10.13	47.43	57.56	64.03	-6.47	QP
4	0.1900	10.13	27.55	37.68	54.03	-16.35	AVG
5	0.2060	10.13	46.27	56.40	63.36	-6.96	QP
6	0.2060	10.13	26.59	36.72	53.36	-16.64	AVG
7	0.2180	10.13	45.07	55.20	62.89	-7.69	QP
8	0.2180	10.13	25.09	35.22	52.89	-17.67	AVG
9	0.2660	10.13	41.47	51.60	61.24	-9.64	QP
10	0.2660	10.13	20.74	30.87	51.24	-20.37	AVG
11	0.3321	10.14	37.35	47.49	59.40	-11.91	QP
12	0.3321	10.14	19.37	29.51	49.40	-19.89	AVG

Note: Measurement Level = Reading Level + Correct Factor



5. Radiated Emission Measurement

5.1 Test Limit

In any 100kHz bandwidth outside the frequency band in which the spread spectrum or digitally modulated intentional radiator is operating, the radio frequency power that is produced by the intentional radiator shall be at least 20dB below that in the 100kHz bandwidth within the band that contains the highest level of the desired power, based on either an RF conducted or a radiated measurement. If the transmitter measurement is based on the maximum conducted output power, the attenuation required under this paragraph shall be 30dB instead of 20dB. In addition, radiated emissions which fall in section 15.205(a) the restricted bands must also comply with the radiated emission limit specified in section 15.209(a).

FREQUENCIES (MHz)	FIELD STRENGTH (micro volts/meter)	MEASUREMENT DISTANCE (meters)
0.009~0.490	2400/F(kHz)	300
0.490~1.705	24000/F(kHz)	30
1.705~30.0	30	30
30~88	100	3
88~216	150	3
216~960	200	3
Above 960	500	3

For unintentional device, according to CISPR PUB.22, for Class B digital devices, the general requirement of field strength of radiated emissions from intentional radiators at a distance of 10 meters shall not exceed the above table.

Frequency (MHz)	Distance Meters	Radiated (dB μ V/ M)
30-230	10	30
230-1000	10	37



5.2 Test Standard

ANSI C63.10-2013-Section 6.10.5

5.3 Test Procedures

- a. The EUT was placed on a rotatable table top 0.8 meter for frequency below 1GHz and 1.5meter for frequency above 1GHz above ground.
- b. The EUT was set 3 meters from the interference receiving antenna which was mounted on the top of a variable height antenna tower.
- c. The table was rotated 360 degrees to determine the position of the highest radiation.
- d. The antenna is a broadband antenna and its height is varied between one meter and four meters above ground to find the maximum value of the field strength both horizontal polarization and vertical polarization of the antenna are set to make the measurement.
- e. For each suspected emission the EUT was arranged to its worst case and then tune the antenna tower (from 1 M to 4 M) and turn table (from 0 degree to 360 degrees) to find the maximum reading.
- f. Set the test-receiver system to Peak or CISPR quasi-peak Detect Function and specified bandwidth with Maximum Hold Mode.
- g. If the emission level of the EUT in peak mode was 3 dB lower than the limit specified, then testing will be stopped and peak values of EUT will be reported, otherwise, the emissions which do not have 3 dB margin will be repeated one by one using the quasi-peak method and reported.
- h. For testing above 1GHz, the emission level of the EUT in peak mode was 20dB lower than average limit (that means the emission level in peak mode also complies with the limit in average mode), then testing will be stopped and peak values of EUT will be reported, otherwise, the emissions will be measured in average mode again and reported.

5.4 Typical Test Setup

9kHz~30MHz Test Setup

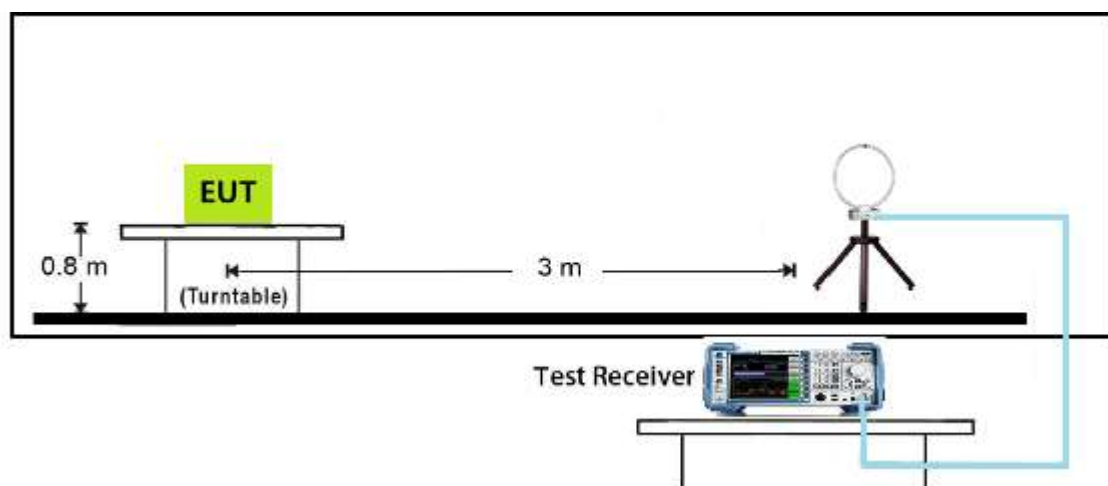



Below 1GHz Test Setup

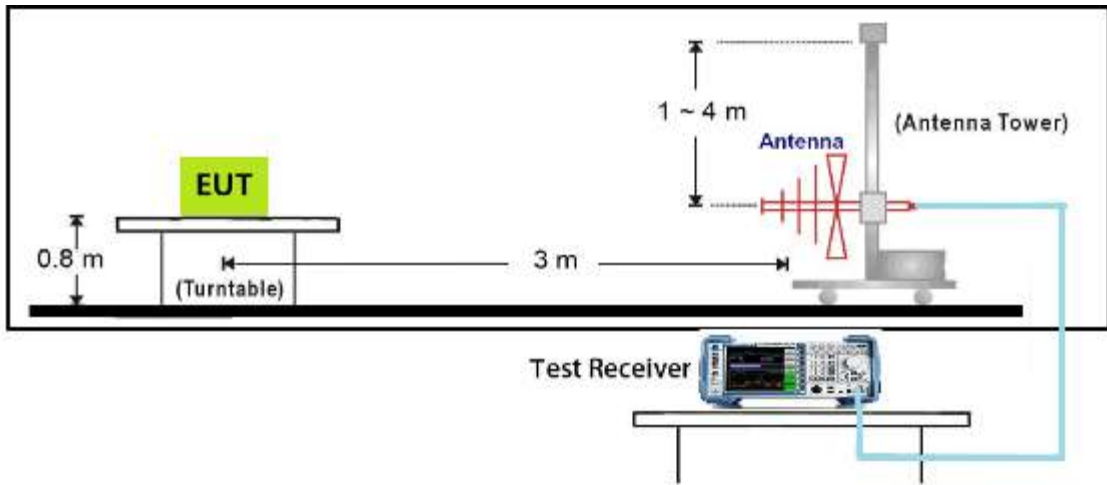

1GHz~18GHz Test Setup

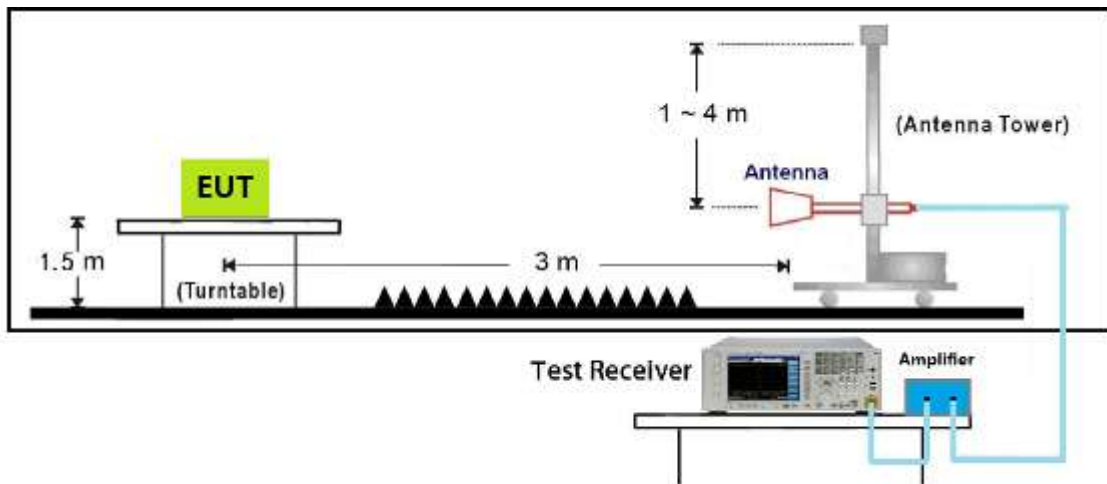

18GHz~40GHz Test Setup

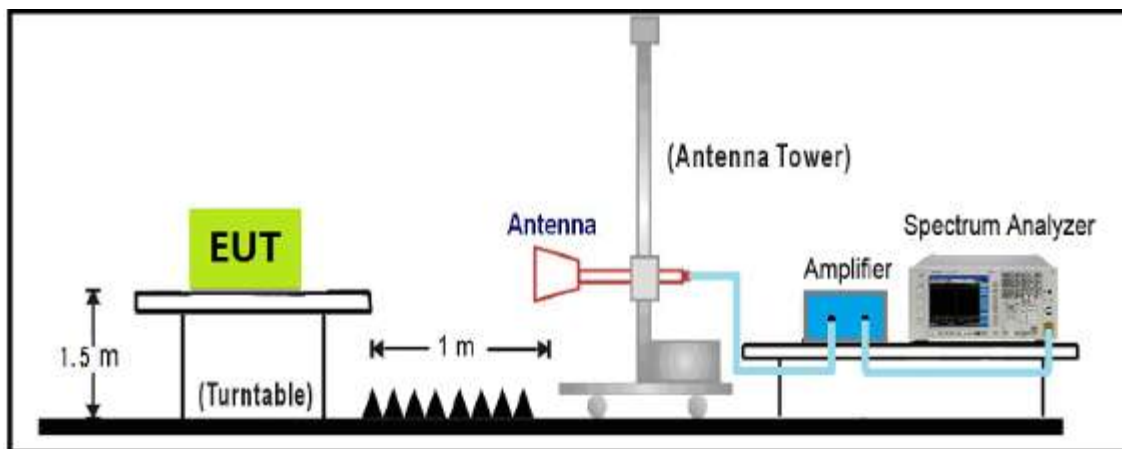



5.5 Test Result and Data

The worst case of Radiated Emission below 1GHz:

Limit: FCC_Part15.209_RE(3m)	Margin: 0
Probe: CBL6112D (30-1000MHz)	Polarity: Horizontal
EUT: Bluetooth® Speaker Charger	Power: AC 120V/60Hz
Note: Mode1: Transmit at channel 2441MHz by DH5	

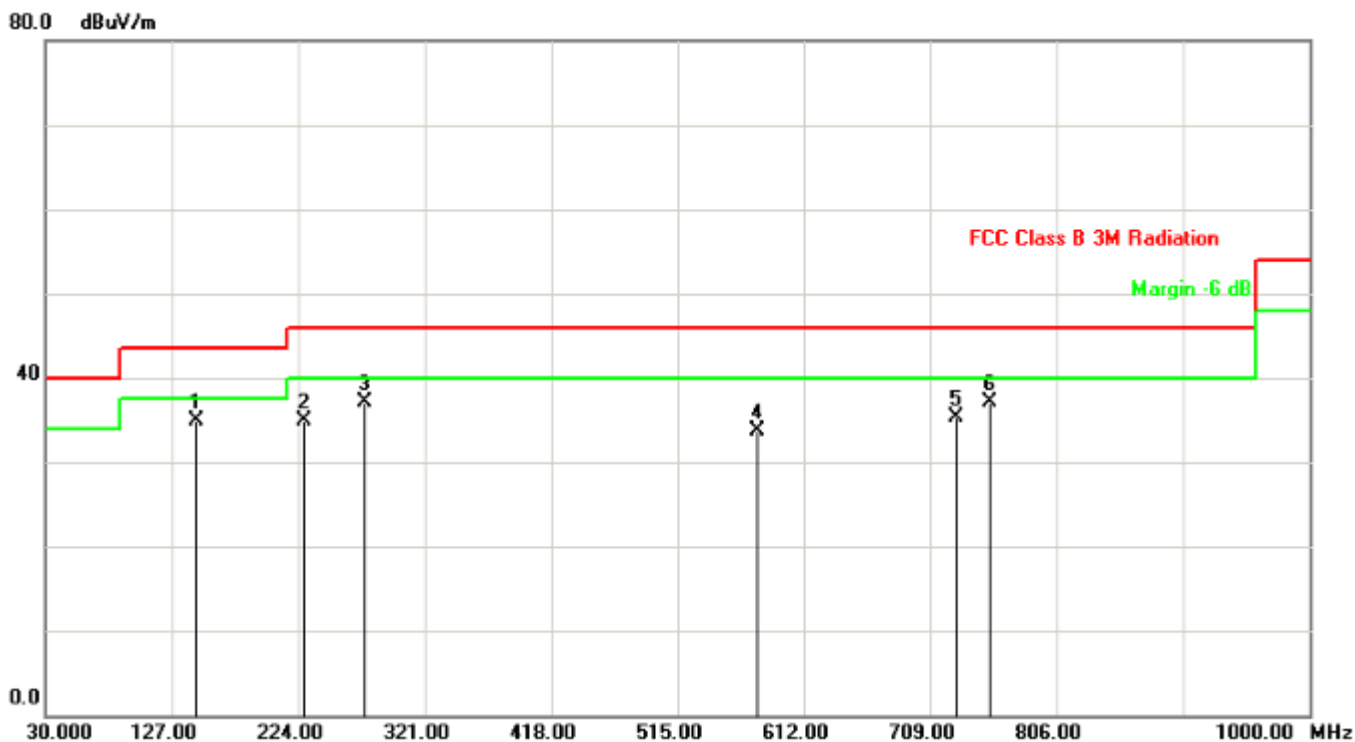

No.	Frequency (MHz)	Factor (dB/m)	Reading (dBuV)	Level (dBuV/m)	Limit (dBuV/m)	Margin (dB)	Det.
1	145.4300	-12.73	47.55	34.82	43.50	-8.68	QP
2	228.8500	-12.07	46.94	34.87	46.00	-11.13	QP
3	274.4400	-9.31	46.39	37.08	46.00	-8.92	QP
4	576.1100	-2.73	36.36	33.63	46.00	-12.37	QP
5	728.4000	1.49	33.91	35.40	46.00	-10.60	QP
6	754.5900	1.27	35.90	37.17	46.00	-8.83	QP

Note: Measure Level (dBuV/m) = Reading Level (dBuV) + Factor(dB).

Factor (dB)=Cable Loss(dB) + Antenna Factor (dB/m) - Pre_Amplifier Gain(dB)



Limit: FCC_Part15.209_RE(3m)	Margin: 0
Probe: CBL6112D (30-1000MHz)	Polarity: Vertical
EUT: Bluetooth® Speaker Charger	Power: AC 120V/60Hz
Note: Mode1: Transmit at channel 2441MHz by DH5	

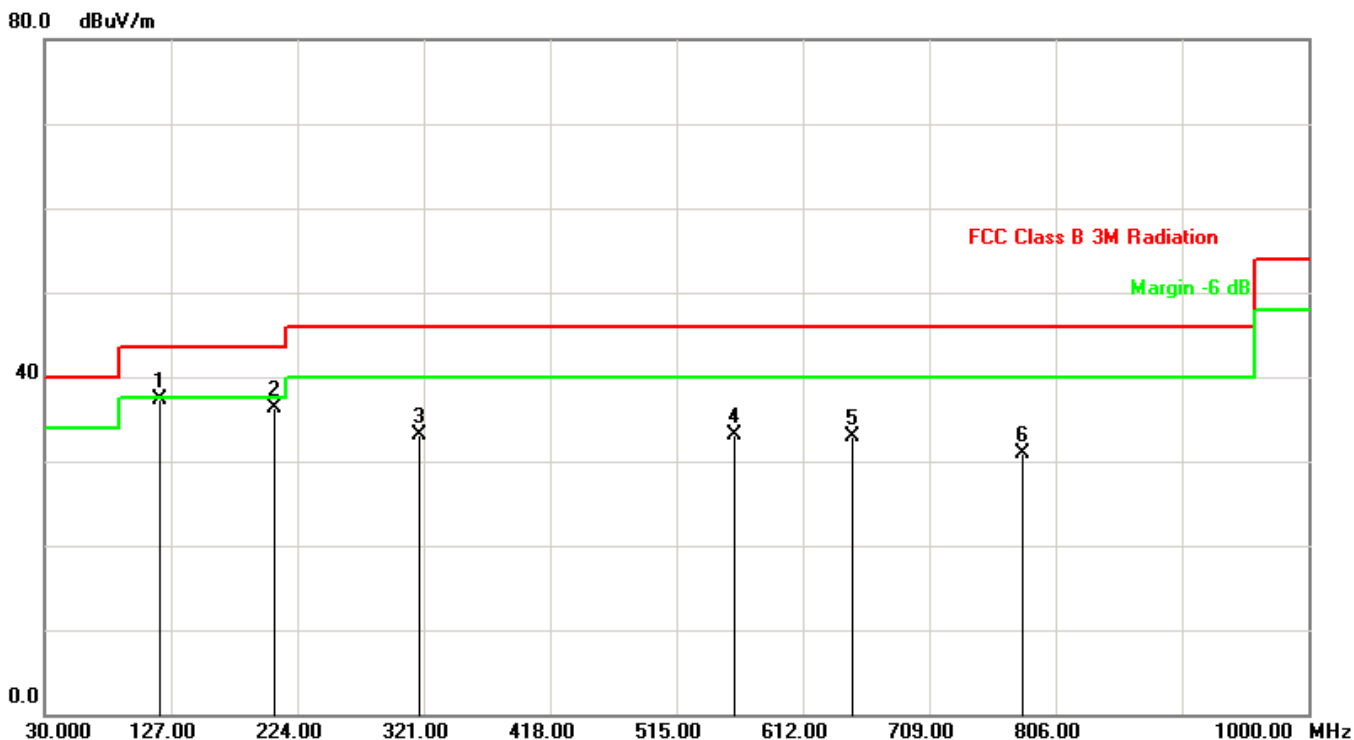

No.	Frequency (MHz)	Factor (dB/m)	Reading (dBuV)	Level (dBuV/m)	Limit (dBuV/m)	Margin (dB)	Det.
1	118.2700	-12.82	50.20	37.38	43.50	-6.12	QP
2	206.5399	-12.35	48.73	36.38	43.50	-7.12	QP
3	318.0900	-6.43	39.58	33.15	46.00	-12.85	QP
4	559.6200	-3.32	36.51	33.19	46.00	-12.81	QP
5	649.8300	-2.30	35.25	32.95	46.00	-13.05	QP
6	780.7800	0.64	30.22	30.86	46.00	-15.14	QP

Note: Measure Level (dBuV/m) = Reading Level (dBuV) + Factor(dB).

Factor (dB)=Cable Loss(dB) + Antenna Factor (dB/m) - Pre_Amplifier Gain(dB)



Radiated Emission above 1GHz:

Engineer: Ternence	
Site: AC102	Time: 2017/11/25
Limit: FCC_Part15.209_RE(3m)	Margin: 0
Probe: BBHA9120D_1-18GHz	Polarity: Vertical
EUT: Bluetooth® Speaker Charger	Power: AC 120V/60Hz
Note: Mode : Transmits at 2441MHz by DH5	

100.0 dBuV/m

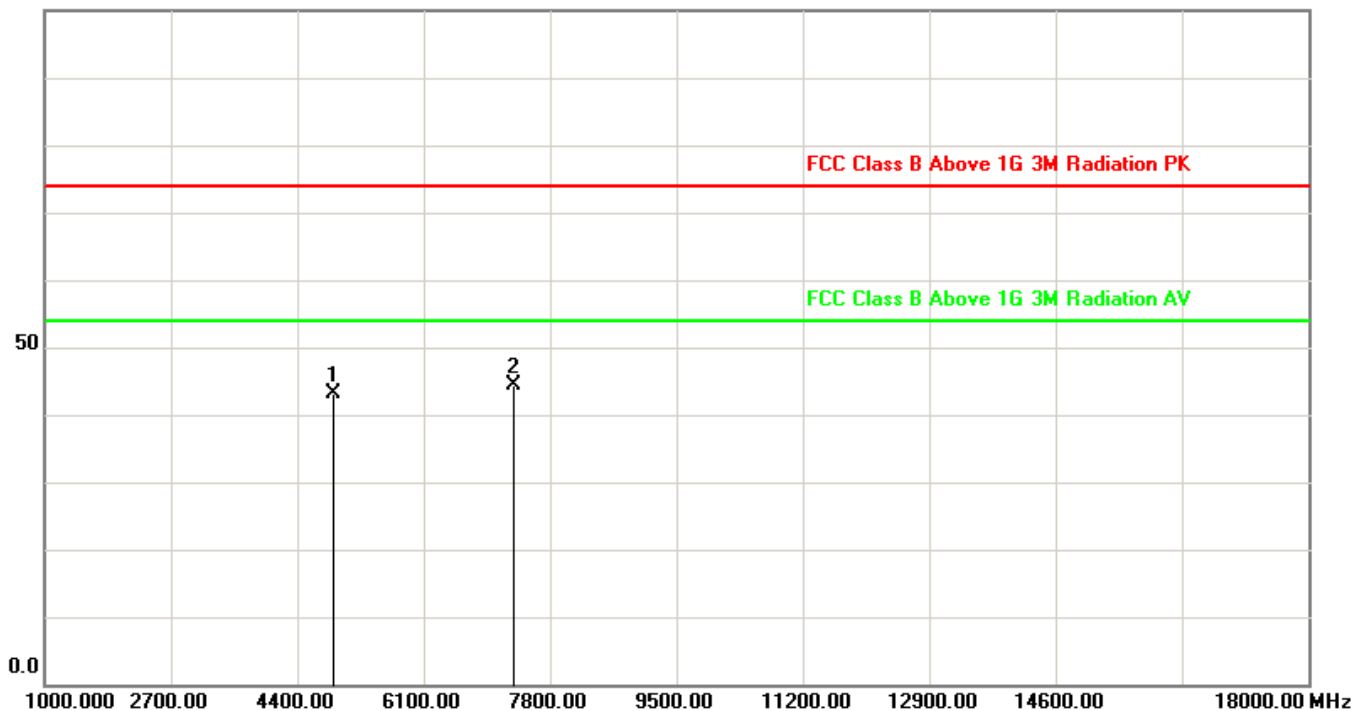

No	Mark	Frequency (MHz)	Measure Level (dBuV/m)	Reading Level (dBuV)	Over Limit (dB)	Limit (dBuV/m)	Factor (dB)	Type
1		4882.000	43.21	39.77	-10.79	54(note3)	3.44	PK
2	*	7323.000	44.42	36.14	-9.58	54(note3)	8.28	PK



Engineer: Ternence	
Site: AC102	Time: 2017/11/25
Limit: FCC_Part15.209_RE(3m)	Margin: 0
Probe: BBHA9120D_1-18GHz	Polarity: Horizontal
EUT: Bluetooth® Speaker Charger	Power: AC 120V/60Hz
Note: Mode : Transmits at 2441MHz by DH5	

100.0 dBuV/m

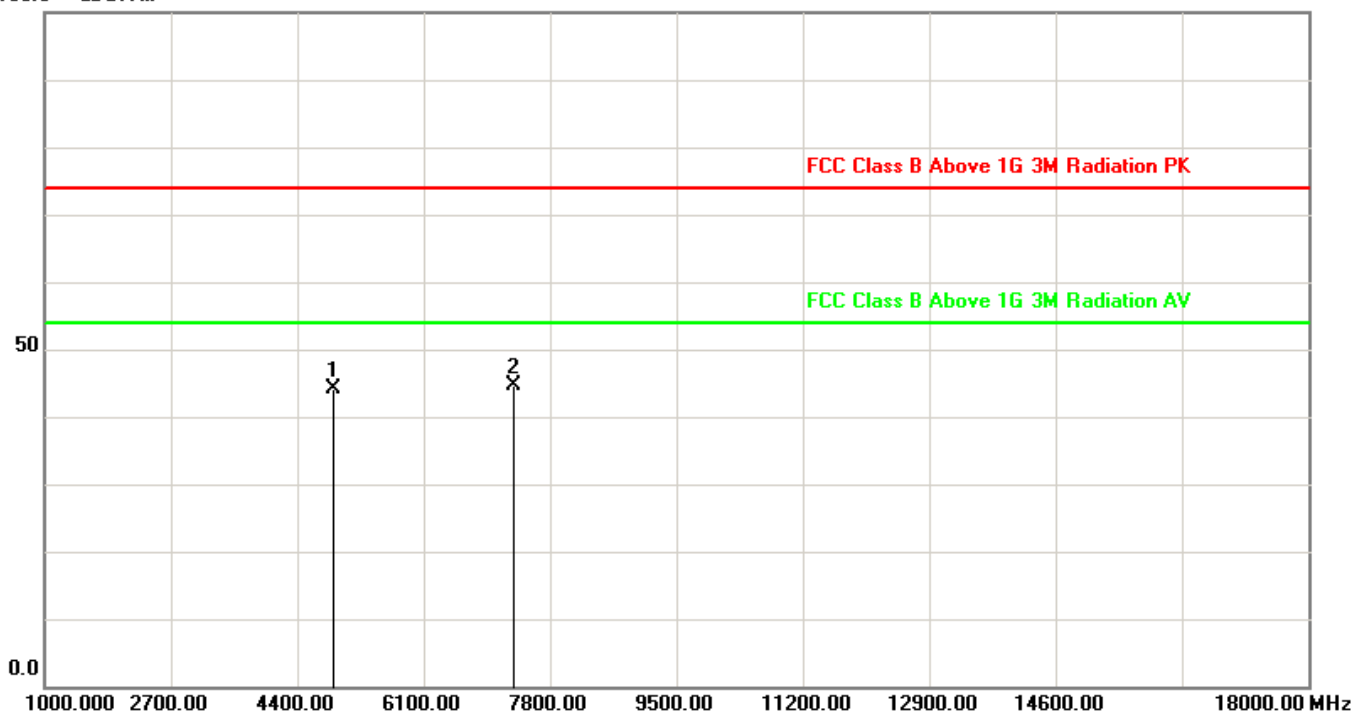

No	Mark	Frequency (MHz)	Measure Level (dBuV/m)	Reading Level (dBuV)	Over Limit (dB)	Limit (dBuV/m)	Factor (dB)	Type
1		4882.000	44.15	40.71	-9.85	54(note3)	3.44	PK
2	*	7323.000	44.75	36.47	-9.25	54(note3)	8.28	PK



Mode1: Transmit by DH5

CH	Antenna	Frequency (MHz)	Reading Level (dBuV/m)	Factor (dB)	Measure Level (dBuV/m)	Limit (dBuV/m)	Margin (dB)	Detector
00	H	4804.0	40.31	3.36	43.67	54(note3)	-10.33	PK
	H	7206.0	34.91	8.27	43.18	54(note3)	-10.82	PK
	V	4804.0	38.95	3.36	42.31	54(note3)	-11.69	PK
	V	7206.0	35.26	8.27	43.53	54(note3)	-10.47	PK
39	H	4882.0	40.71	3.44	44.15	54(note3)	-9.85	PK
	H	7323.0	36.47	8.28	44.75	54(note3)	-9.25	PK
	V	4882.0	39.77	3.44	43.21	54(note3)	-10.79	PK
	V	7323.0	36.14	8.28	44.42	54(note3)	-9.58	PK
79	H	4960.0	40.61	3.43	44.04	54(note3)	-9.96	PK
	H	7440.0	36.05	8.28	44.33	54(note3)	-9.67	PK
	V	4960.0	39.33	3.43	42.76	54(note3)	-11.24	PK
	V	7440.0	35.89	8.28	44.17	54(note3)	-9.83	PK

Note: 1. Measure Level = Reading Level + Factor.

2. The test trace is same as the ambient noise (the test frequency range: 9kHz~30MHz, 18GHz~25GHz), therefore no data appear in the report.

3. This limit applies for using average detector, if the test result on peak is lower than average limit, then average measurement needn't be performed.



Mode2: Transmit by 2DH5

CH	Antenna	Frequency (MHz)	Reading Level (dBuV/m)	Factor (dB)	Measure Level (dBuV/m)	Limit (dBuV/m)	Margin (dB)	Detector
00	H	4804.0	37.89	3.36	41.25	54(note3)	-12.75	PK
	H	7206.0	34.15	8.27	42.42	54(note3)	-11.58	PK
	V	4804.0	38.28	3.36	41.64	54(note3)	-12.36	PK
	V	7206.0	31.88	8.27	40.15	54(note3)	-13.85	PK
39	H	4882.0	40.02	3.44	43.46	54(note3)	-10.54	PK
	H	7323.0	34.49	8.28	42.77	54(note3)	-11.23	PK
	V	4882.0	39.8	3.44	43.24	54(note3)	-10.76	PK
	V	7323.0	34.09	8.28	42.37	54(note3)	-11.63	PK
79	H	4960.0	37.34	3.43	40.77	54(note3)	-13.23	PK
	H	7440.0	31.94	8.28	40.22	54(note3)	-13.78	PK
	V	4960.0	35.79	3.43	39.22	54(note3)	-14.78	PK
	V	7440.0	32.16	8.28	40.44	54(note3)	-13.56	PK

Note: 1. Measure Level = Reading Level + Factor.

2. The test trace is same as the ambient noise (the test frequency range: 9kHz~30MHz, 18GHz~25GHz), therefore no data appear in the report.

3. This limit applies for using average detector, if the test result on peak is lower than average limit, then average measurement needn't be performed.



Mode3: Transmit by 3DH5

CH	Antenna	Frequency (MHz)	Reading Level (dBuV/m)	Factor (dB)	Measure Level (dBuV/m)	Limit (dBuV/m)	Margin (dB)	Detector
00	H	4804.0	36.08	3.36	39.44	54(note3)	-14.56	PK
	H	7206.0	31.78	8.27	40.05	54(note3)	-13.95	PK
	V	4804.0	35.83	3.36	39.19	54(note3)	-14.81	PK
	V	7206.0	30.72	8.27	38.99	54(note3)	-15.01	PK
39	H	4882.0	38.21	3.44	41.65	54(note3)	-12.35	PK
	H	7323.0	32.74	8.28	41.02	54(note3)	-12.98	PK
	V	4882.0	37.33	3.44	40.77	54(note3)	-13.23	PK
	V	7323.0	32.08	8.28	40.36	54(note3)	-13.64	PK
79	H	4960.0	34.93	3.43	38.36	54(note3)	-15.64	PK
	H	7440.0	29.75	8.28	38.03	54(note3)	-15.97	PK
	V	4960.0	35.22	3.43	38.65	54(note3)	-15.35	PK
	V	7440.0	29.67	8.28	37.95	54(note3)	-16.05	PK

Note: 1. Measure Level = Reading Level + Factor.

2. The test trace is same as the ambient noise (the test frequency range: 9kHz~30MHz, 18GHz~25GHz), therefore no data appear in the report.

3. This limit applies for using average detector, if the test result on peak is lower than average limit, then average measurement needn't be performed.



6. 20dB Bandwidth Measurement

6.1 Test Limit

Frequency hopping systems shall have hopping channel carrier frequencies separated by a minimum of 25 kHz or the 20 dB bandwidth of the hopping channel, whichever is greater. Alternatively, frequency hopping systems operating in the 2400–2483.5 MHz band may have hopping channel carrier frequencies that are separated by 25 kHz or two-thirds of the 20 dB bandwidth of the hopping channel, whichever is greater, provided the systems operate with an output power no greater than 125mW.

6.2 Test Standard

ANSI C63.10-2013- Section 7.8.7

6.3 Test Setup

1. Set RBW $\geq 1\%$ of the 20dB bandwidth
2. VBW $\geq 3 \times$ RBW
3. Span = approximately 2 to 3 times the 20dB bandwidth, centered on a hopping channel
4. Detector = Peak
5. Trace mode = max hold
6. Sweep = auto couple
7. Allow the trace to stabilize
8. Measure the maximum width of the emission that is constrained by the frequencies associated with the two outermost amplitude points (upper and lower frequencies) that are attenuated by 20dB relative to the maximum level measured in the fundamental emission

6.4 Test Setup Layout

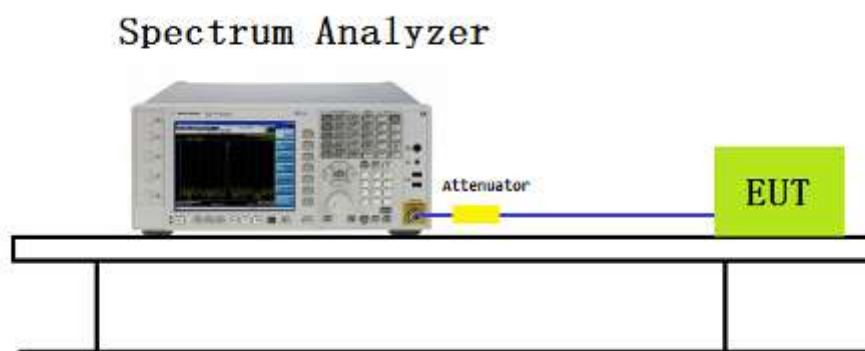



6.5 Test Result and Data

Test Item	Occupied Bandwidth
Test Mode	Mode 1: Transmitter DH5

Channel No.	Frequency(MHz)	20dB Bandwidth(kHz)	99% Bandwidth(kHz)
00	2402	907.8	865.55
39	2441	908.3	865.78
78	2480	908.7	869.48

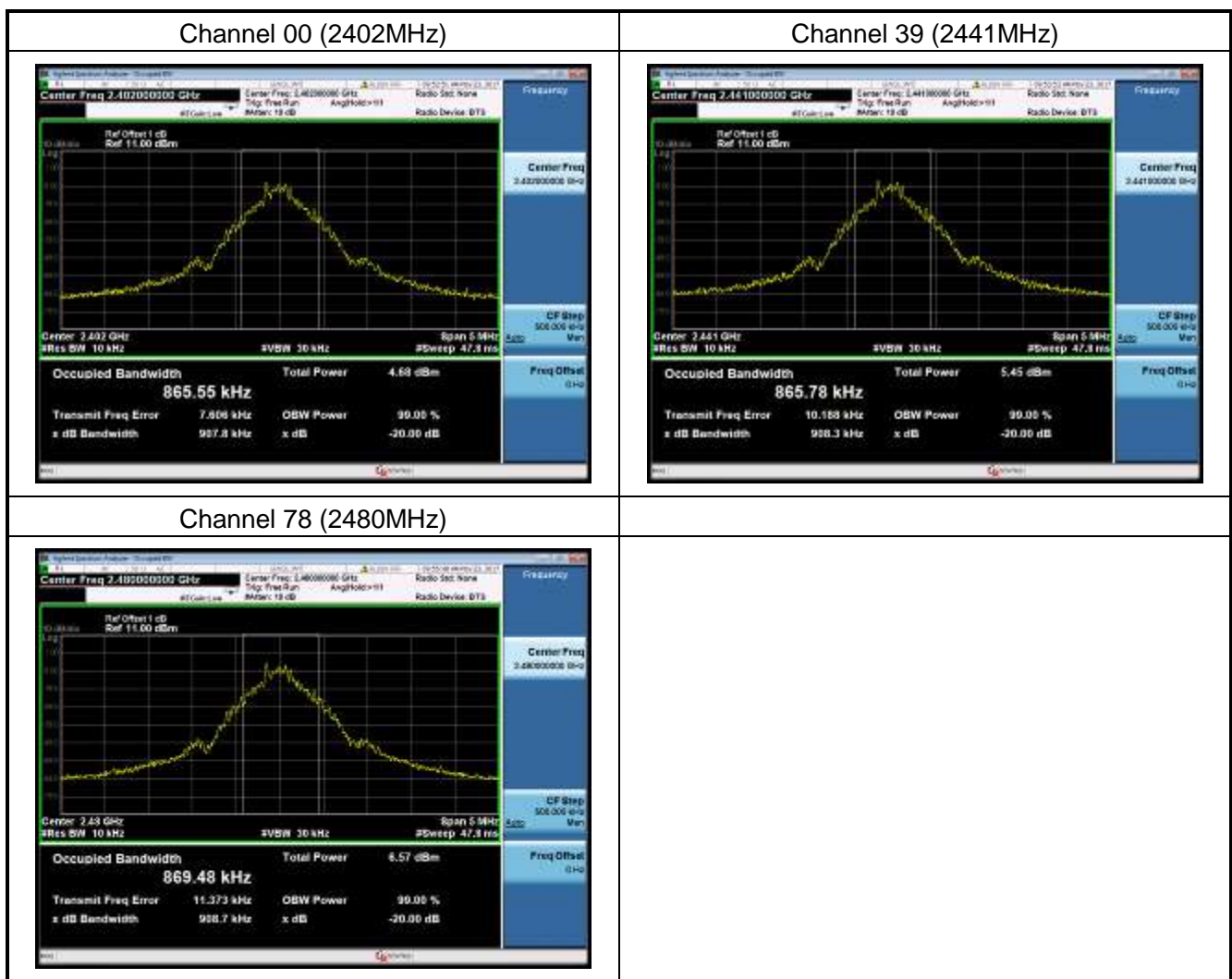



Test Item	Occupied Bandwidth
Test Mode	Mode 2: Transmitter 2DH5

Channel No.	Frequency(MHz)	20dB Bandwidth(kHz)	99% Bandwidth(kHz)
00	2402	1287	1175.2
39	2441	1289	1175.6
78	2480	1290	1178.6

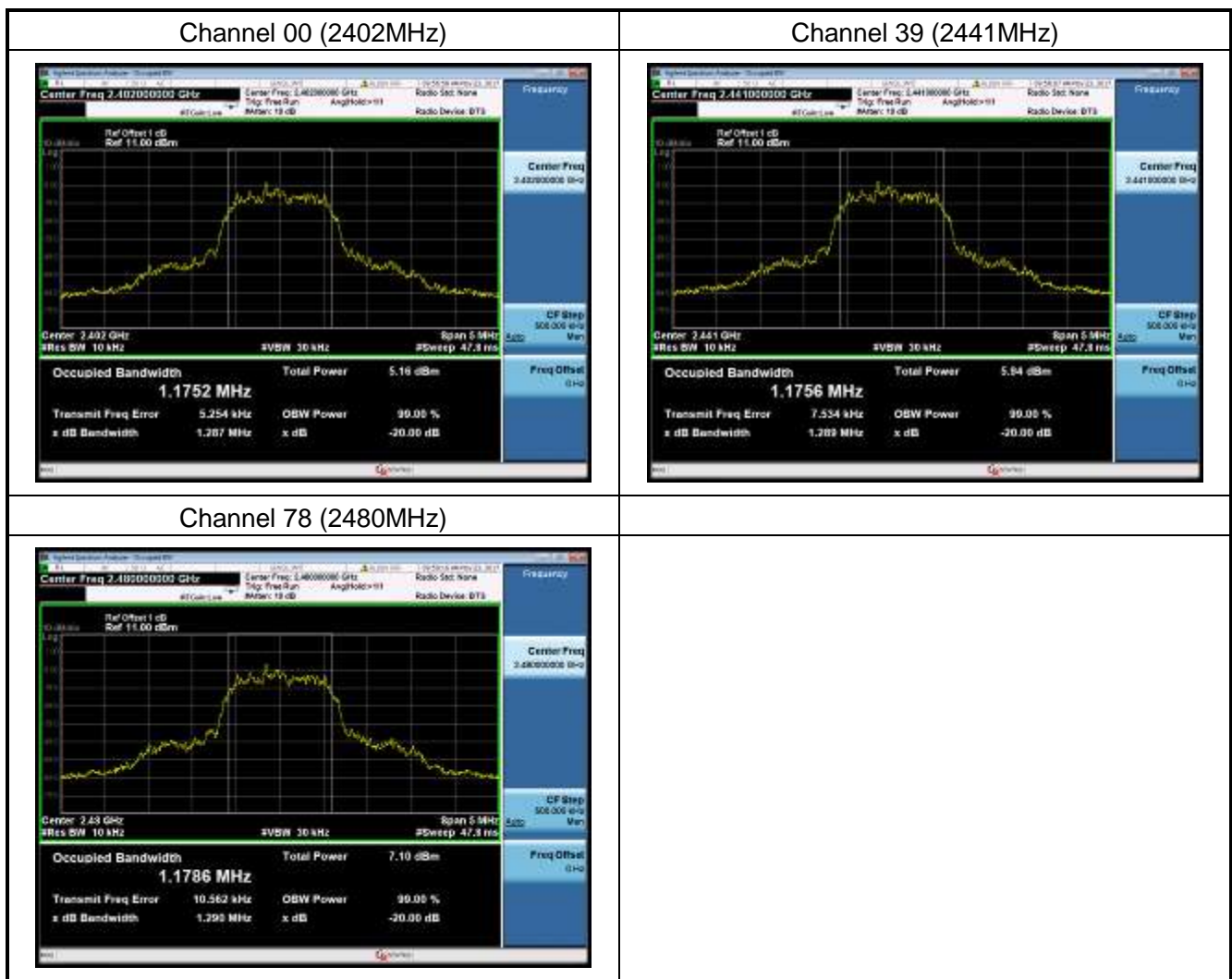



Test Item	Occupied Bandwidth
Test Mode	Mode 3: Transmitter 3DH5

Channel No.	Frequency(MHz)	20dB Bandwidth(kHz)	99% Bandwidth(kHz)
00	2402	1261	1180.3
39	2441	1262	1181.4
78	2480	1262	1184.0

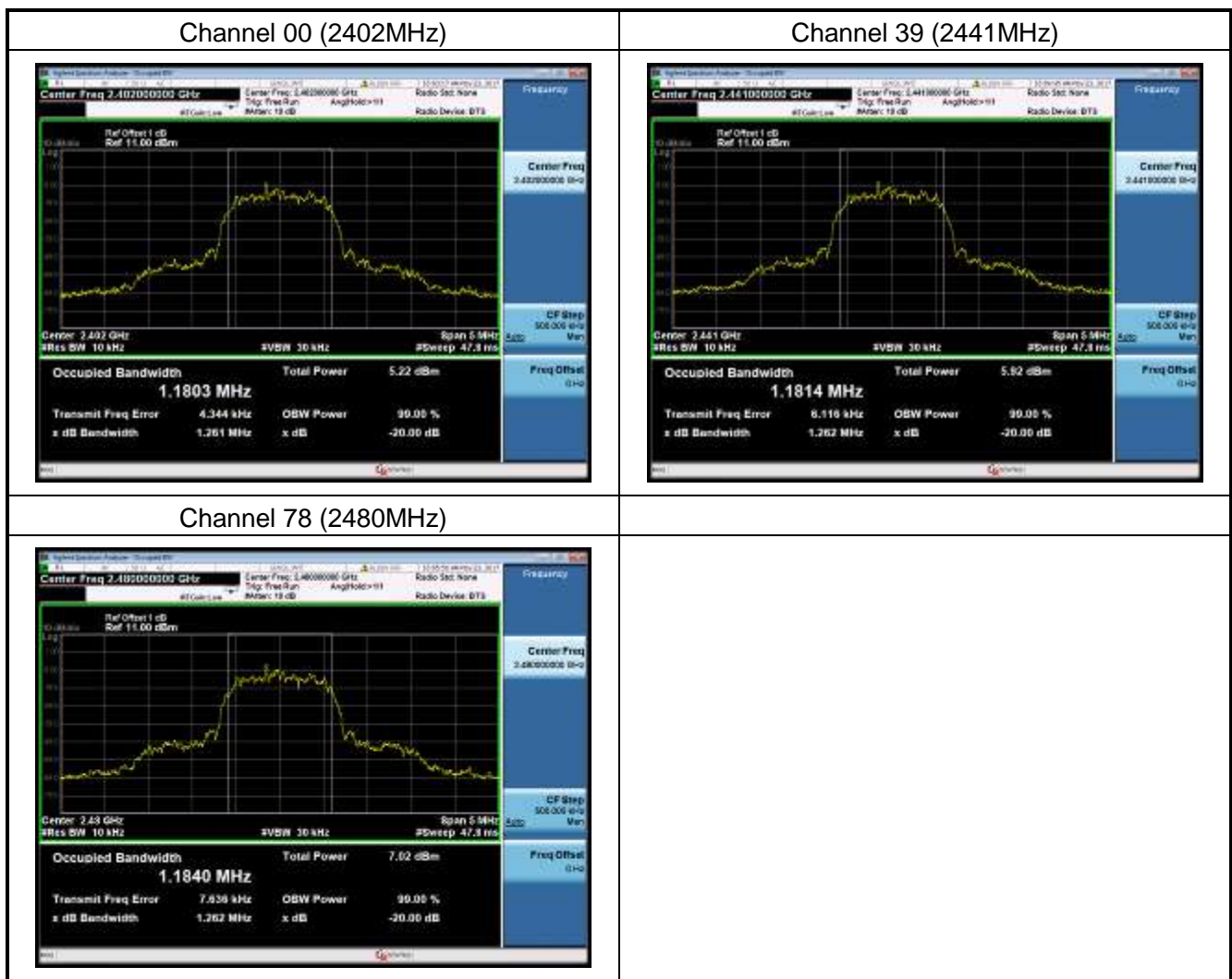



7. Channel Carrier Frequencies Separation Measurement

7.1 Test Limit

Frequency hopping systems shall have hopping channel carrier frequencies separated by a minimum of 25 kHz or the 20 dB bandwidth of the hopping channel, whichever is greater.

7.2 Test Standard

ANSI C63.10-2013- Section 7.8.2

7.3 Test Setup

The EUT shall have its hopping function enabled. Use the following spectrum analyzer settings:

- Span: Wide enough to capture the peaks of two adjacent channels.
- RBW: Start with the RBW set to approximately 30% of the channel spacing; adjust as necessary to best identify the center of each individual channel.
- Video (or average) bandwidth (VBW) \geq RBW
- Sweep: Auto
- Detector function: Peak
- Trace: Max hold
- Allow the trace to stabilize

Use the marker-delta function to determine the separation between the peaks of the adjacent channels. Compliance of an EUT with the appropriate regulatory limit shall be determined. A plot of the data shall be included in the test report.

7.4 Test Setup Layout

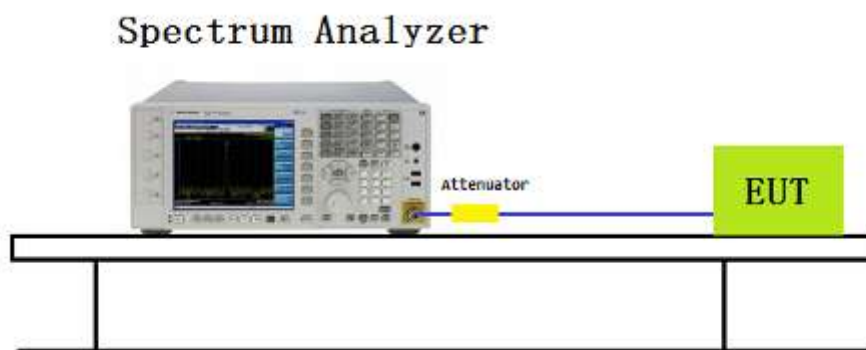



7.5 Test Result and Data

Test Item	:	Channel Carrier Frequency Separation
Test Mode	:	Mode 1: Transmitter DH5

Channel No.	Frequency (MHz)	Carrier Frequency Separation (kHz)	Limit (kHz)	Result
00	2402	1000	>25 kHz or 2/3 of 20 dB BW	Pass
39	2441	1000	>25 kHz or 2/3 of 20 dB BW	Pass
78	2480	1000	>25 kHz or 2/3 of 20 dB BW	Pass

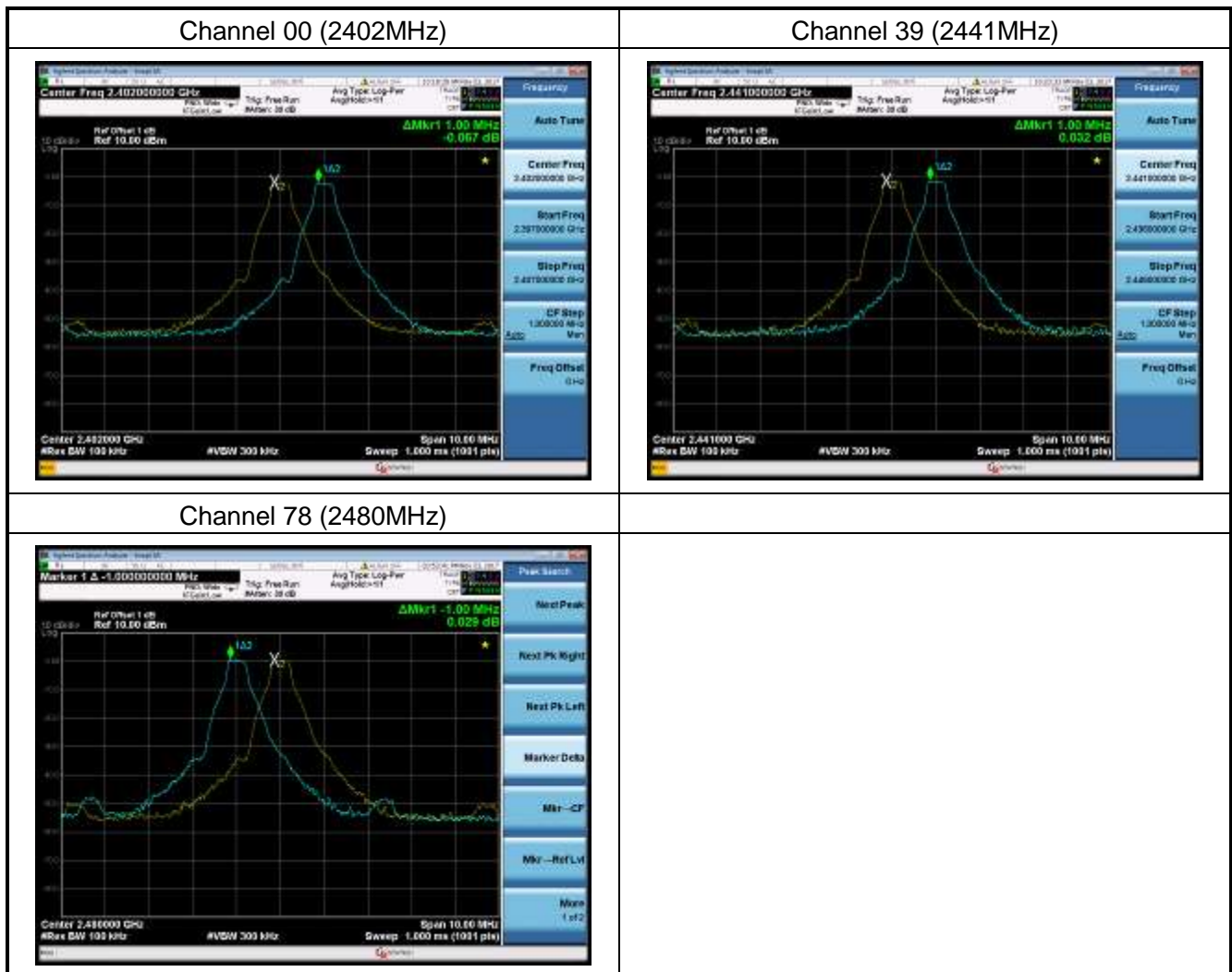



Test Item	:	Carrier Frequency Separation
Test Mode	:	Mode 2: Transmitter 2DH5

Channel No.	Frequency (MHz)	Carrier Frequency Separation(kHz)	Limit (kHz)	Result
00	2402	1000	>25 kHz or 2/3 of 20 dB BW	Pass
39	2441	1000	>25 kHz or 2/3 of 20 dB BW	Pass
78	2480	1000	>25 kHz or 2/3 of 20 dB BW	Pass

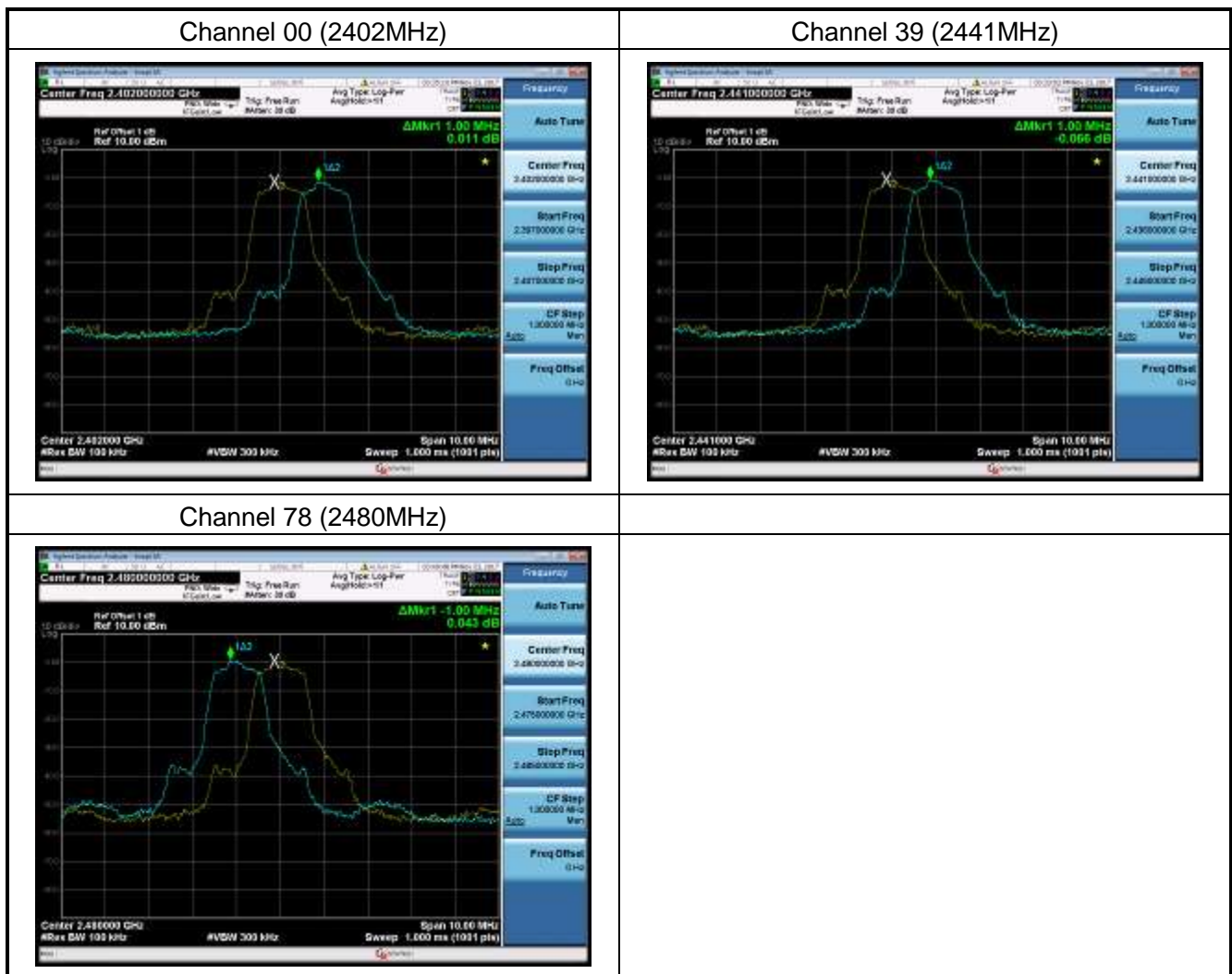



Test Item	:	Carrier Frequency Separation
Test Mode	:	Mode 3: Transmitter 3DH5

Channel No.	Frequency (MHz)	Carrier Frequency Separation (kHz)	Limit (kHz)	Result
00	2402	1000	>25 kHz or 2/3 of 20 dB BW	Pass
39	2441	1000	>25 kHz or 2/3 of 20 dB BW	Pass
78	2480	1000	>25 kHz or 2/3 of 20 dB BW	Pass

Channel 00 (2402MHz)

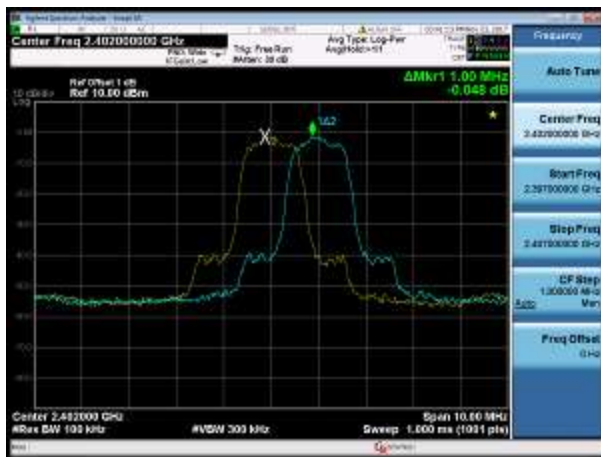

Channel 39 (2441MHz)

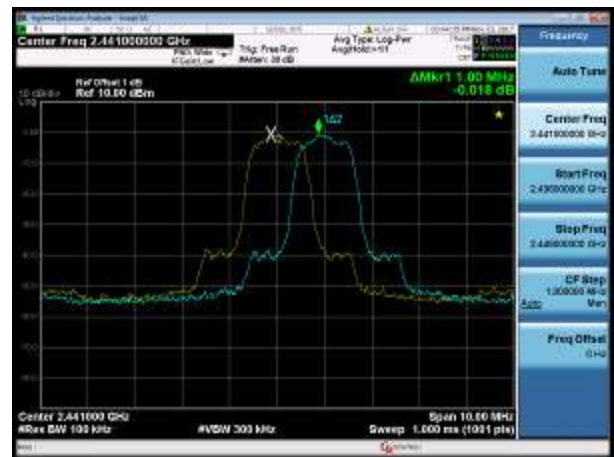

Channel 78 (2480MHz)

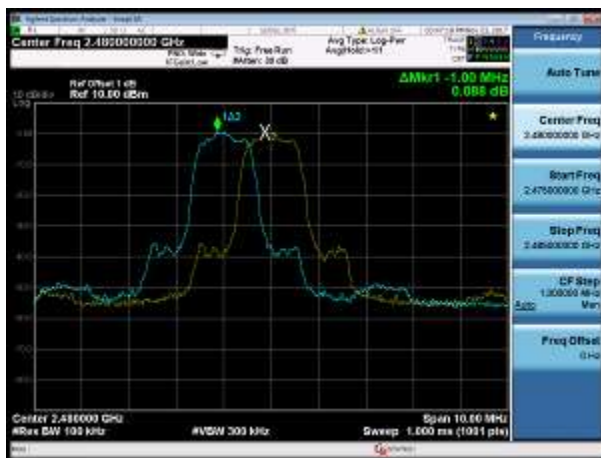



8. Dwell Time Measurement

8.1 Test Limit

The average time of occupancy on any channel shall not be greater than 0.4 seconds within a period of 0.4 seconds multiplied by the number of hopping channels employed.

8.2 Test Standard

ANSI C63.10-2013- Section 7.8.3

8.3 Test Setup

The EUT shall have its hopping function enabled. Use the following spectrum analyzer settings:

- Span: Zero span, centered on a hopping channel.
- RBW shall be \leq channel spacing and where possible RBW should be set $\gg 1 / T$, where T is the expected dwell time per channel.
- Sweep: As necessary to capture the entire dwell time per hopping channel; where possible use a video trigger and trigger delay so that the transmitted signal starts a little to the right of the start of the plot. The trigger level might need slight adjustment to prevent triggering when the system hops on an adjacent channel; a second plot might be needed with a longer sweep time to show two successive hops on a channel.
- Detector function: Peak
- Trace: Max hold

8.4 Test Setup Layout

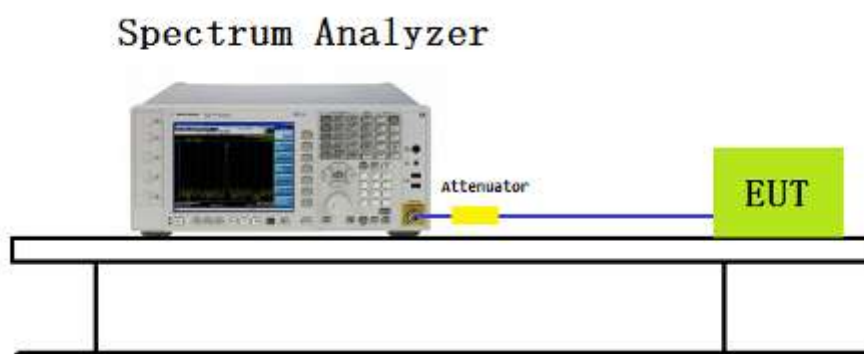



8.5 Test Result and Data

Test Item	:	Time of Occupancy (Dwell Time)
Test Mode	:	Transmitter 3DH1

Channel No.	Frequency (MHz)	Time of Occupancy (ms)	Limit (ms)	Result
39	2441	128	< 400	Pass

Test Time Period: $0.4 \times 79 = 31.6$ sec, Hopping Times Within 1sec: $40/50$ msec = 800 hops/sec.
 2441MHz, The Maximum Occupancy Time Within 31.6sec: $[(0.4\text{ms} \times 800)/79] \times 31.6 = 128$ msec

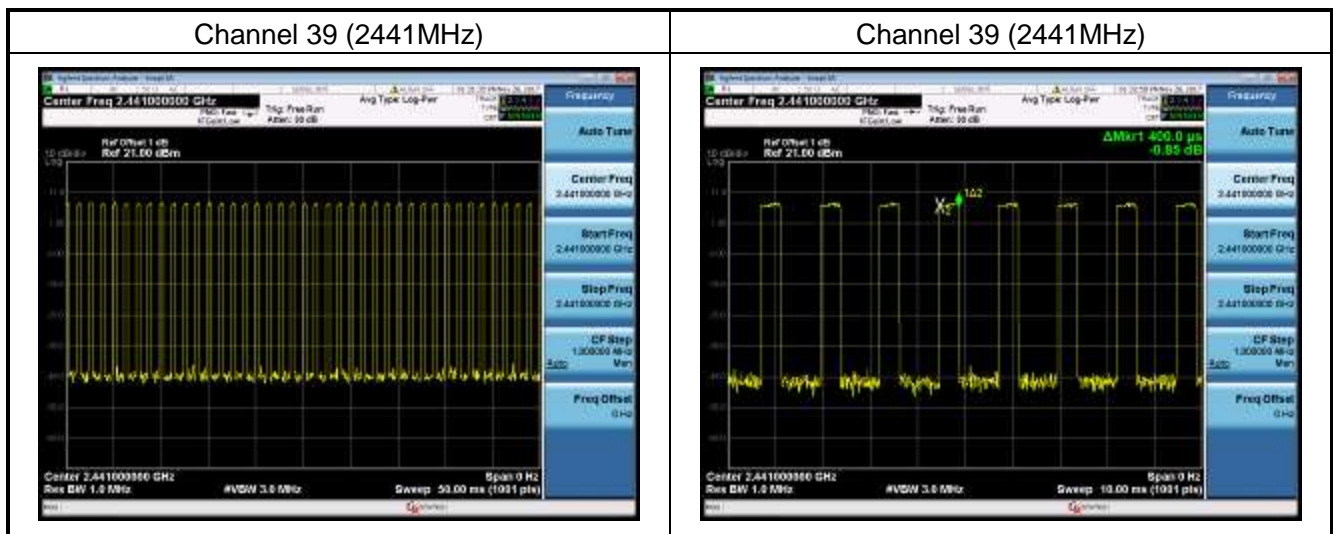



Test Item	:	Time of Occupancy (Dwell Time)
Test Mode	:	Transmitter 3DH3

Channel No.	Frequency (MHz)	Time of Occupancy (ms)	Limit (ms)	Result
39	2441	270.4	< 400	Pass

Test Time Period: $0.4 \times 79 = 31.6$ sec, Hopping Times Within 1sec: $20/50$ msec= 400 hops/sec.

2441MHz, The Maximum Occupancy Time Within 31.6sec: $[(1.69\text{ms} \times 400) / 79] \times 31.6 = 270.4$ msec

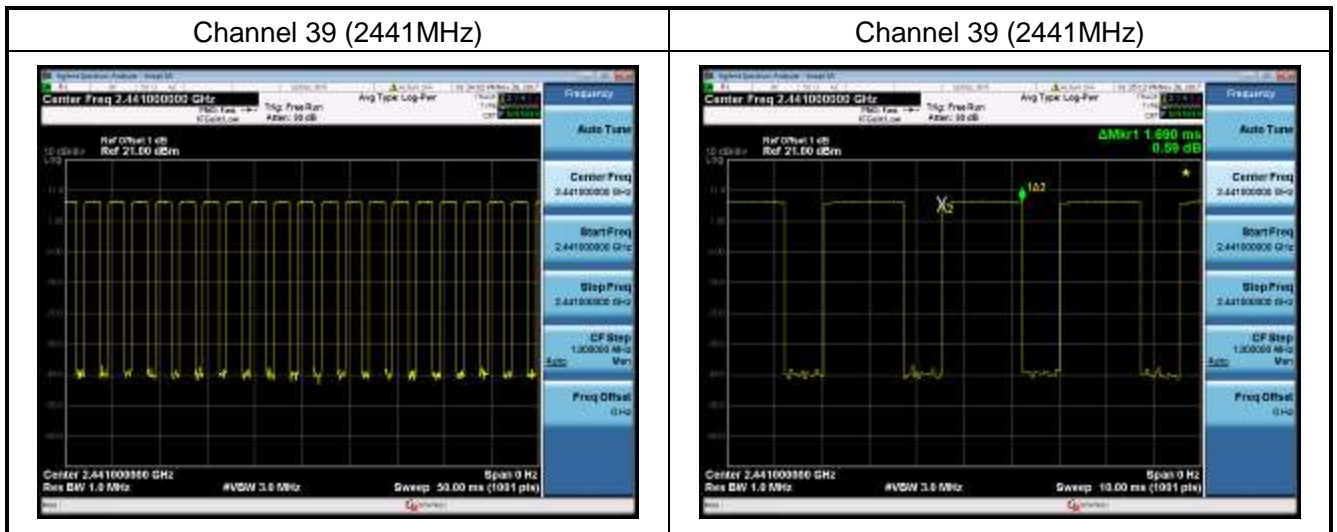



Test Item	:	Time of Occupancy (Dwell Time)
Test Mode	:	Transmitter 3DH5

Channel No.	Frequency (MHz)	Time of Occupancy (ms)	Limit (ms)	Result
39	2441	301.6	< 400	Pass

Test Time Period: $0.4 \times 79 = 31.6$ sec, Hopping Times Within 1sec: $13/50$ msec= 260 hops/sec.

2441MHz, The Maximum Occupancy Time Within 31.6sec: $[(2.9\text{ms} \times 260)/79] \times 31.6 = 301.6$ msec

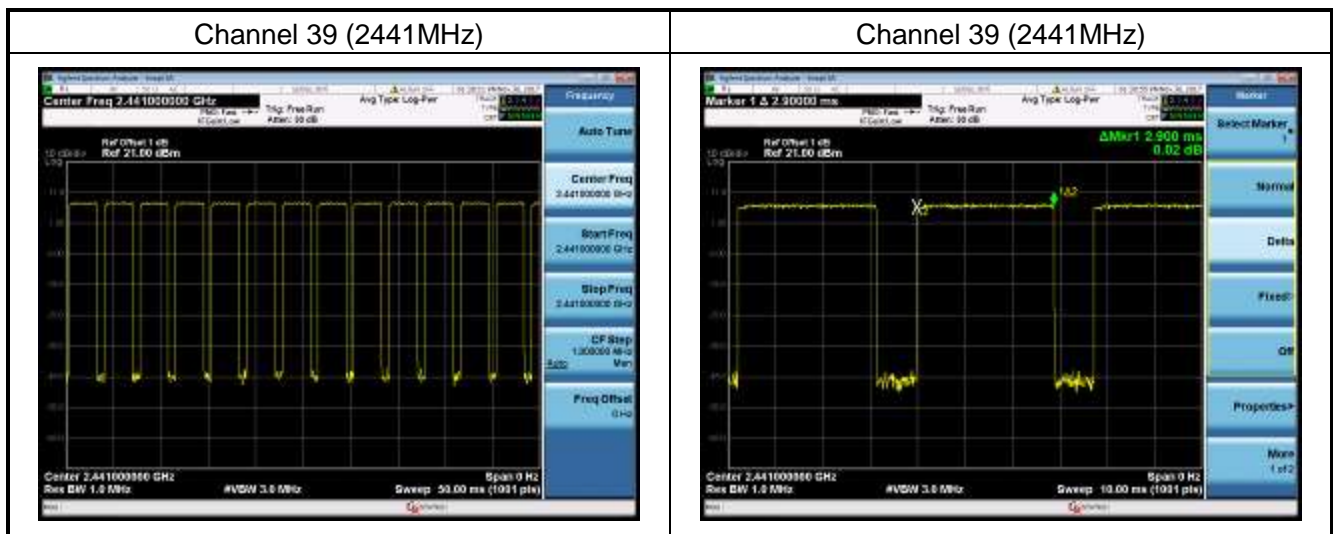



9. Number of Hopping Channels Measurement

9.1 Test Limit

Frequency hopping systems in the 2400 ~ 2483.5 MHz band shall use at least 15 channels.

9.2 Test Standard

ANSI C63.10-2013- Section 7.8.3

9.3 Test Setup

The EUT shall have its hopping function enabled. Use the following spectrum analyzer settings:

- a) Span: The frequency band of operation. Depending on the number of channels the device supports, it may be necessary to divide the frequency range of operation across multiple spans, to allow the individual channels to be clearly seen.
- b) RBW: To identify clearly the individual channels, set the RBW to less than 30% of the channel spacing or the 20 dB bandwidth, whichever is smaller.
- c) VBW \geq RBW
- d) Sweep: Auto
- e) Detector function: Peak
- f) Trace: Max hold
- g) Allow the trace to stabilize

9.4 Test Setup Layout

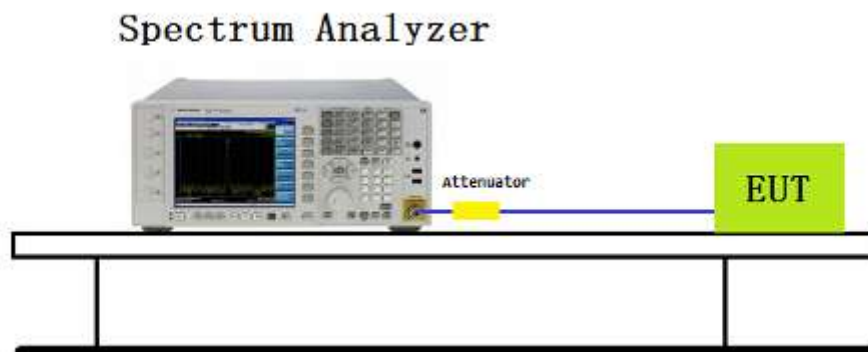



9.5 Test Result and Data

Test Item	:	Number of Hopping Frequencies
Test Mode	:	Mode 1: Transmitter DH5

Frequency Band (MHz)	Number of Hopping Frequencies	Limit	Result
2400 - 2483.5	79	>15	Pass

2402 - 2480 MHz

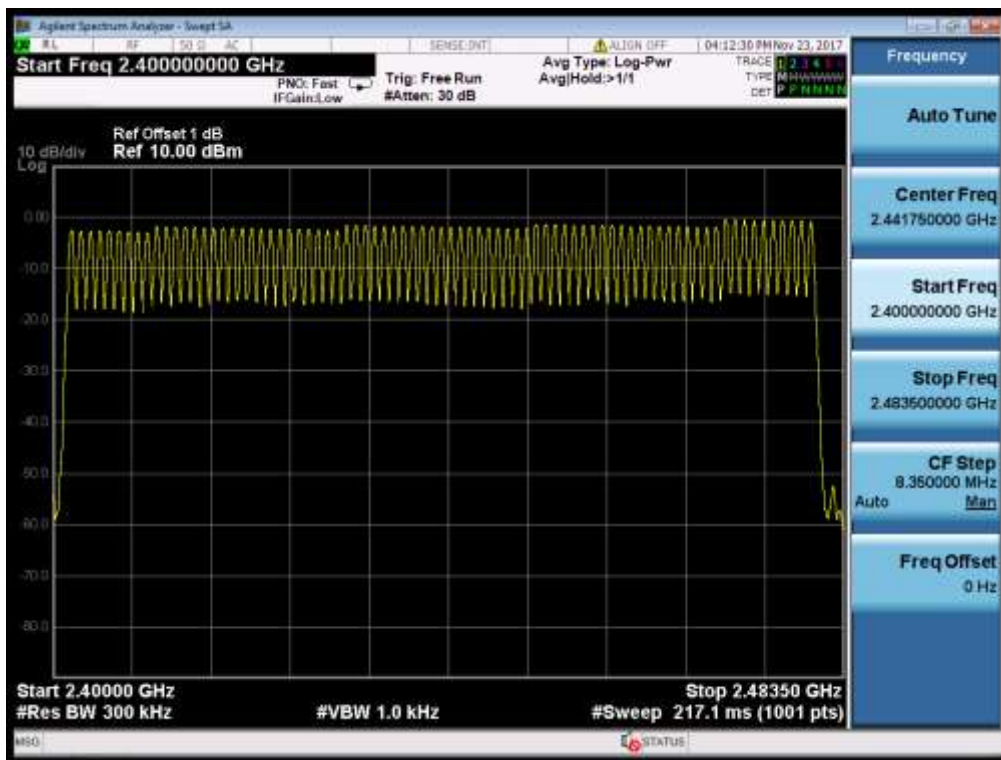



Test Item	:	Number of Hopping Frequencies
Test Mode	:	Mode 2: Transmitter 2DH5

Frequency Band (MHz)	Number of Hopping Frequencies	Limit	Result
2400 - 2483.5	79	>15	Pass

2402 - 2480 MHz

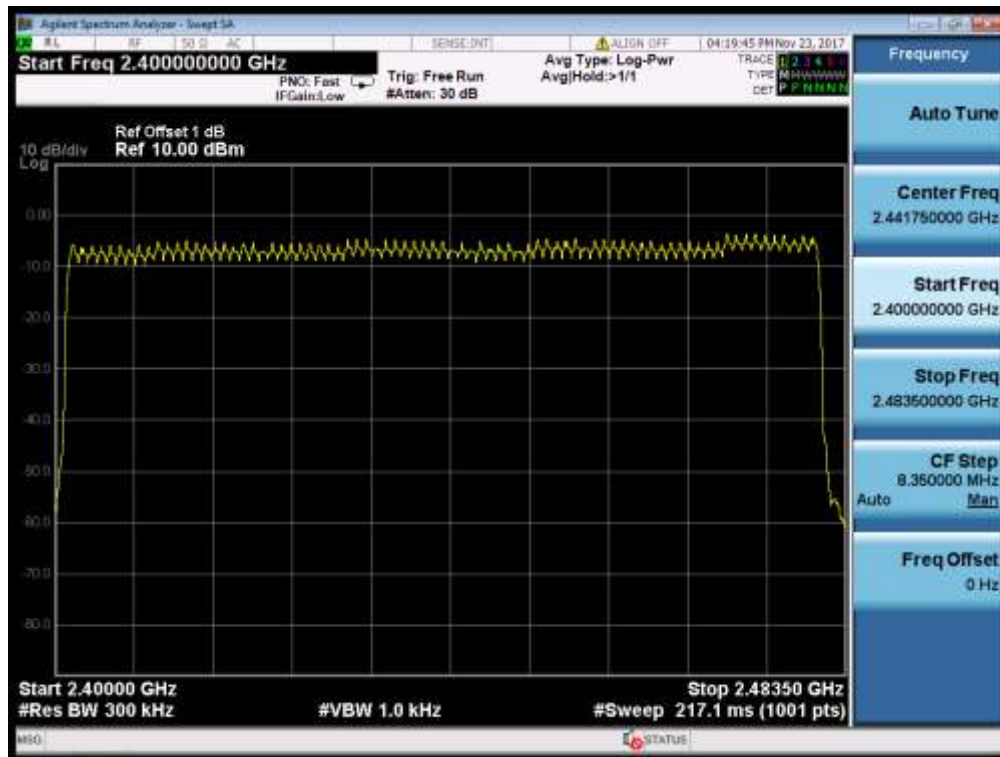



Test Item	:	Number of Hopping Frequencies
Test Mode	:	Mode 3: Transmitter 3DH5

Frequency Band (MHz)	Number of Hopping Frequencies	Limit	Result
2400 - 2483.5	79	>15	Pass

2402 - 2480 MHz

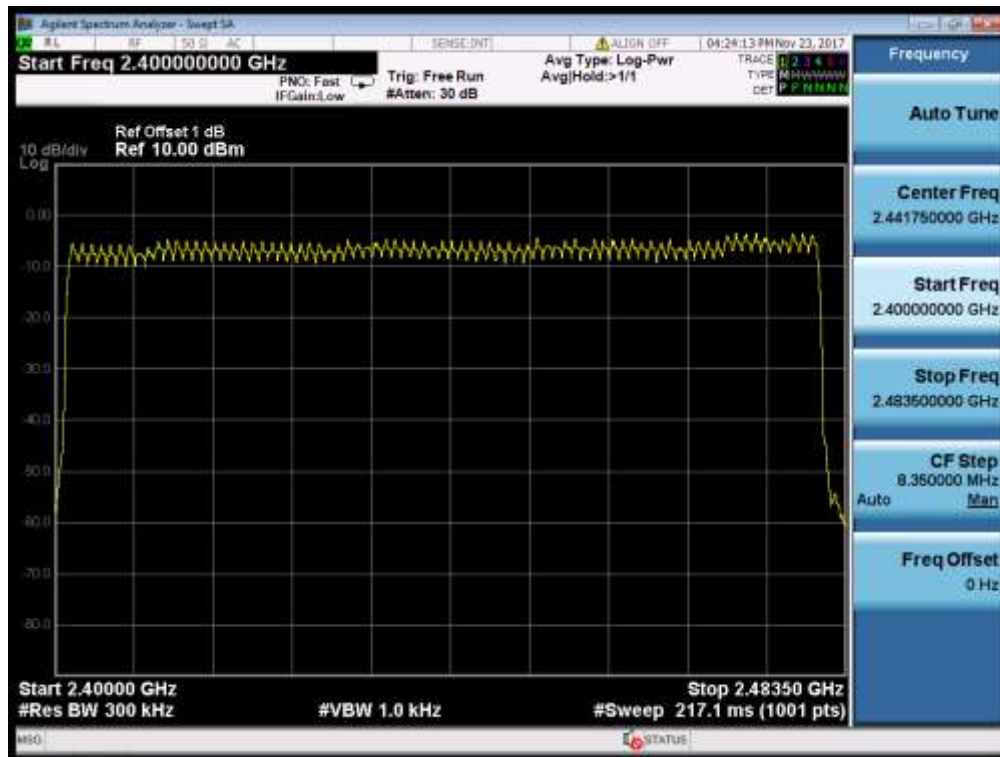



10. Peak Output Power Measurement

10.1 Test Limit

The Maximum Peak Output Power Measurement is 125mW (20.97dBm).

10.2 Test Standard

ANSI C63.10-2013- Section 7.8.5

10.3 Test Setup

Spectrum analyzer method

a) Use the following spectrum analyzer settings:

- 1) Span: Approximately five times the 20 dB bandwidth, centered on a hopping channel.
 - 2) RBW > 20 dB bandwidth of the emission being measured.
 - 3) VBW \geq RBW.
 - 4) Sweep: Auto.
 - 5) Detector function: Peak.
 - 6) Trace: Max hold.
- b) Allow trace to stabilize.
- c) Use the marker-to-peak function to set the marker to the peak of the emission.
- d) The indicated level is the peak output power, after any corrections for external attenuators and cables.
- e) A plot of the test results and setup description shall be included in the test report

Peak power meter method

The antenna port (RF output) of the EUT was connected to the input (RF input) of a power meter. Power was read directly from the meter and cable loss connection was added to the reading to obtain power at the EUT antenna terminal. The EUT Output Power was set to maximum to produce the worse case test result.

10.4 Test Setup Layout

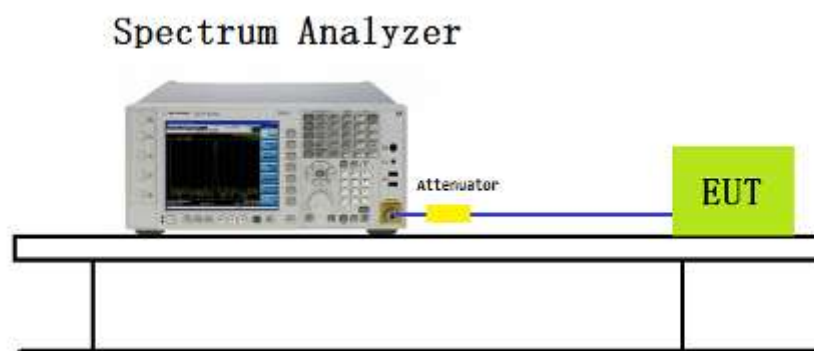



10.5 Test Result and Data

Test Item	:	Peak Output Power
Test Mode	:	Mode 1: Transmitter DH5

Channel No.	Frequency (MHz)	Measurement Power Output (dBm)	Limit (dBm)	Result
0	2402	-0.562	20.97	Pass
39	2441	-0.381	20.97	Pass
78	2480	0.432	20.97	Pass

Test Item	:	Peak Output Power
Test Mode	:	Mode 2: Transmitter 2DH5

Channel No.	Frequency (MHz)	Measurement Power Output (dBm)	Limit (dBm)	Result
0	2402	2.578	20.97	Pass
39	2441	2.845	20.97	Pass
78	2480	3.816	20.97	Pass

Test Item	:	Peak Output Power
Test Mode	:	Mode 3: Transmitter 3DH5

Channel No.	Frequency (MHz)	Measurement Power Output (dBm)	Limit (dBm)	Result
0	2402	2.910	20.97	Pass
39	2441	3.193	20.97	Pass
78	2480	3.813	20.97	Pass

**For EIRP Power :**

Test Mode	Channel No.	Frequency (MHz)	Measurement Power Output (dBm)	EIRP Power (dBm)	Limit(dBm)	Result
DH5	0	2402	-0.562	-0.062	36.02	Pass
	39	2441	-0.381	0.119	36.02	Pass
	78	2480	0.432	0.932	36.02	Pass
2DH5	0	2402	2.578	3.078	36.02	Pass
	39	2441	2.845	3.345	36.02	Pass
	78	2480	3.816	4.316	36.02	Pass
3DH5	0	2402	2.910	3.41	36.02	Pass
	39	2441	3.193	3.693	36.02	Pass
	78	2480	3.813	4.313	36.02	Pass

Note: EIRP Power = Measurement Power Output + Antenna Gain



11. Conducted Spurious Emissions Measurement

11.1 Limit

In any 100 kHz bandwidth outside the frequency band in which the spread spectrum or digitally modulated intentional radiator is operating, the radio frequency power that is produced by the intentional radiator shall be at least 20 dB below that in the 100 kHz bandwidth within the band that contains the highest level of the desired power, based on either an RF conducted or a radiated measurement, provided the transmitter demonstrates compliance with the peak conducted or a radiated measurement, provided the transmitter demonstrates compliance with the peak conducted power limits. If the transmitter complies with the conducted power limits based on the use of RMS averaging over a time interval, the attenuation required under this paragraph shall be 30 dB instead of 20 dB. Attenuation below the general limits specified in Section 15.209(a) of FCC part 15 is not required.



11.2 Test Procedure

According to ANSI C63.10: 2013.

Use the following spectrum analyzer settings:

Span = wide enough to capture the peak level of the in-band emission and all spurious emissions (e.g., harmonics) from the lowest frequency generated in the EUT up through the 10th harmonic. Typically, several plots are required to cover this entire span.

RBW = 100 kHz

VBW \geq RBW

Sweep = auto

Detector function = peak

Trace = max hold

Allow the trace to stabilize. Set the marker on the peak of any spurious emission recorded. The level displayed must comply with the limit specified in this section.

11.3 Test Setup

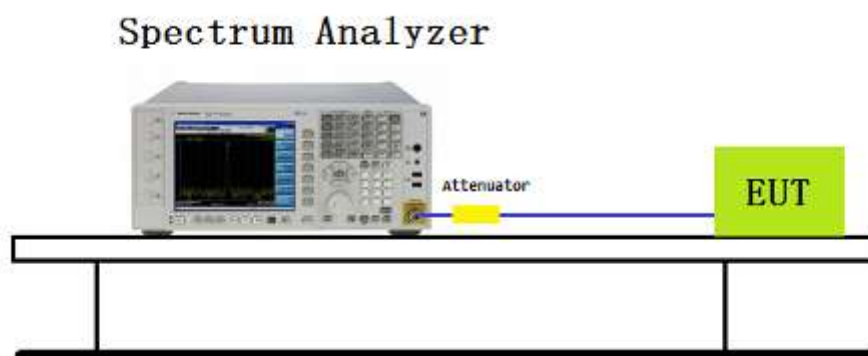



11.4 Test Result

Test Item	: Conducted Spurious Emissions
Test Mode	: Mode 1: Transmitter DH5

Mode 1: Transmit by DH5 (2402MHz)

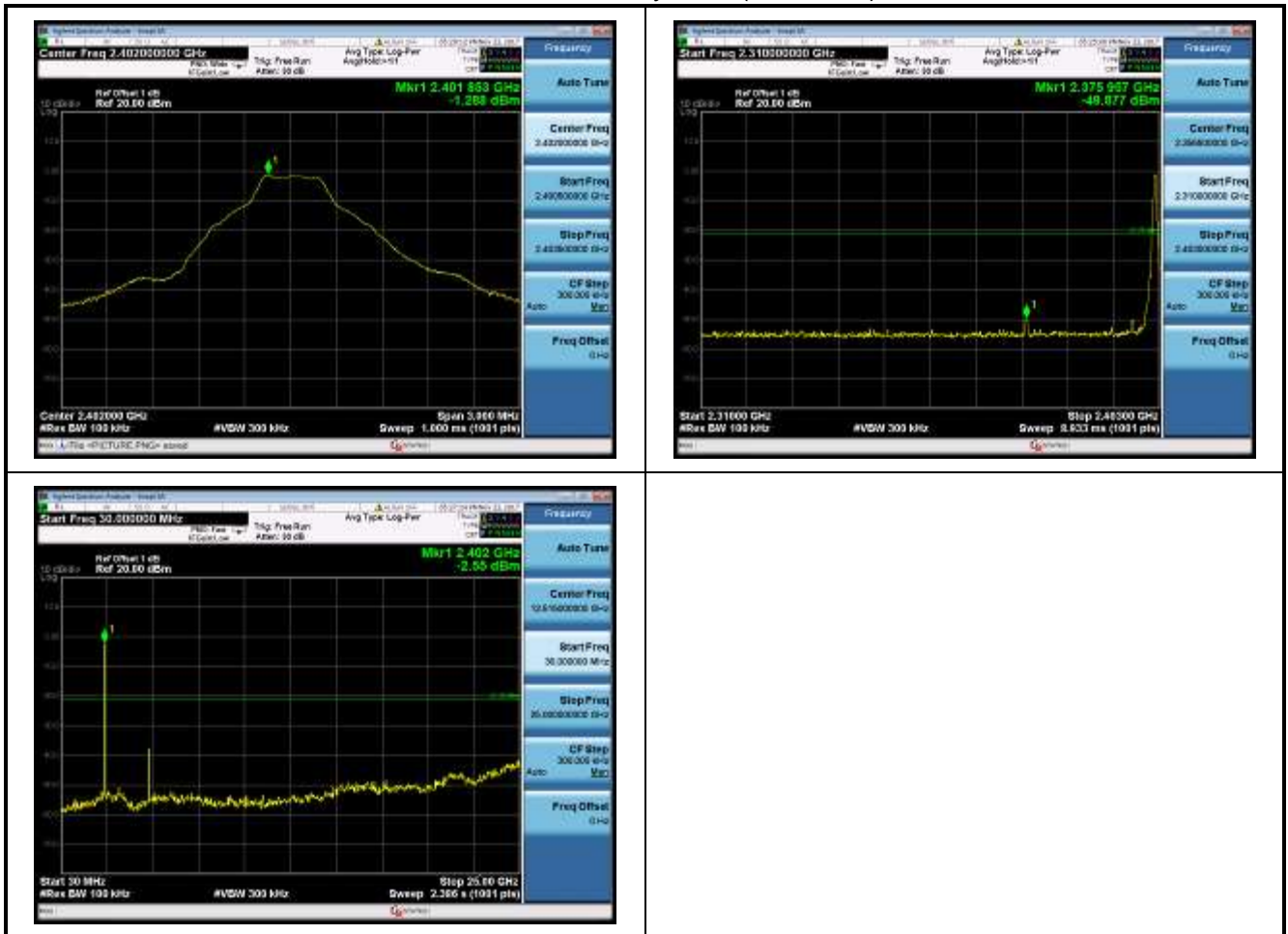



Mode 1: Transmit by DH5 (2441MHz)

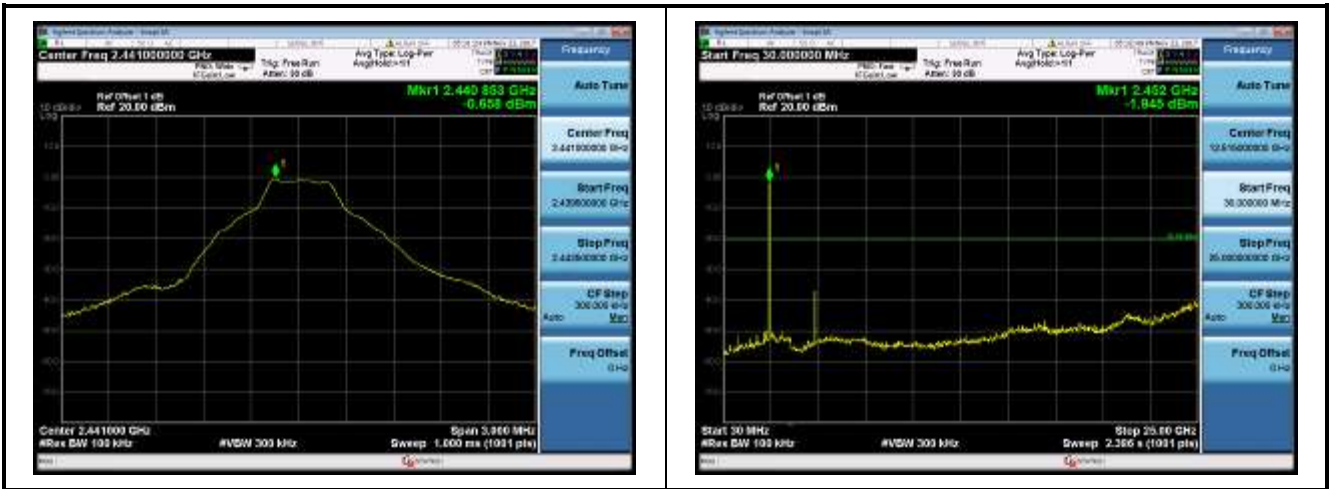

Mode 1: Transmit by DH5 (2480MHz)

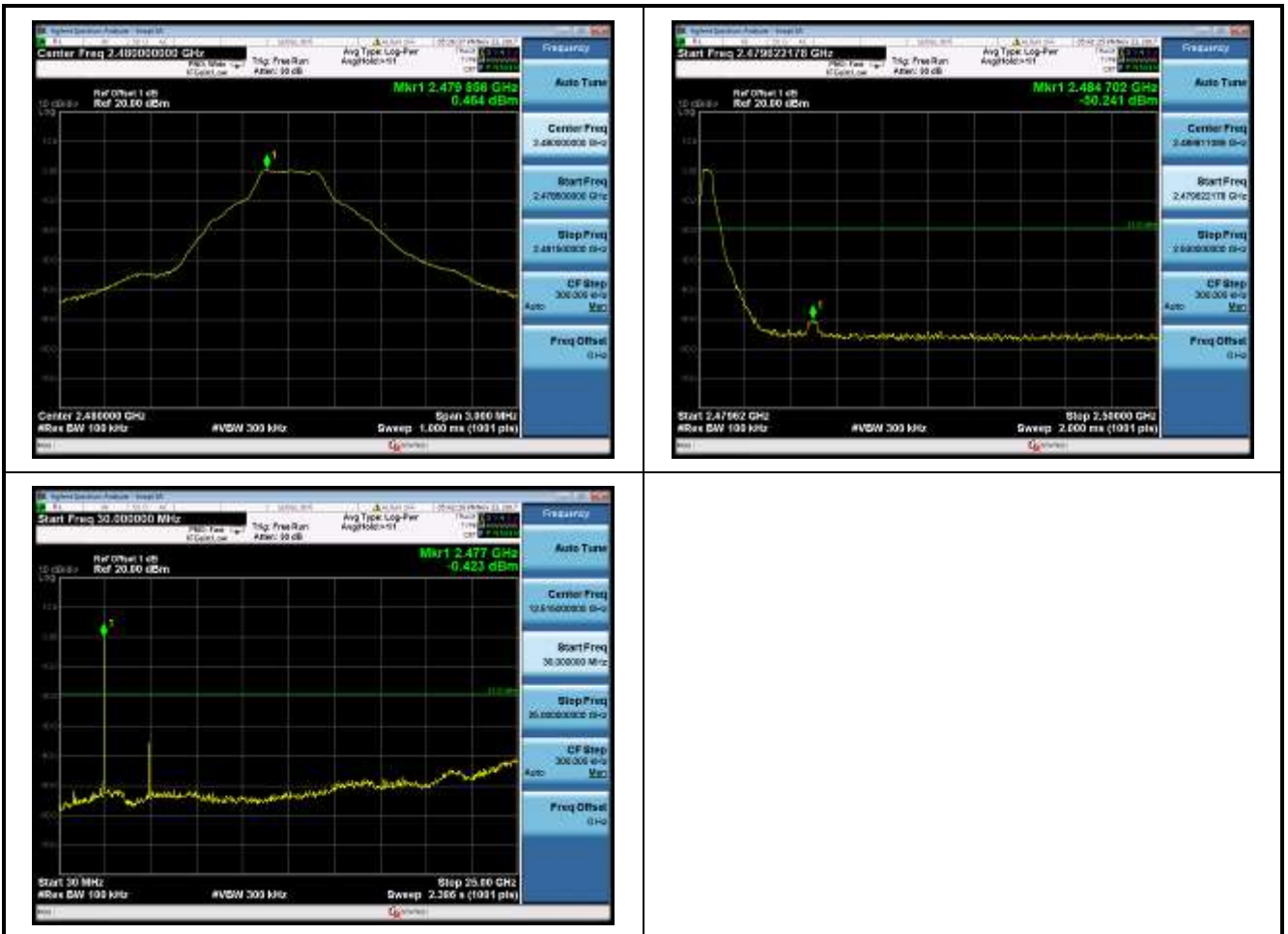



Test Item	:	Conducted Spurious Emissions
Test Mode	:	Mode 2: Transmitter 2DH5

Mode 2: Transmit by 2DH5 (2402MHz)





Mode 2: Transmit by 2DH5 (2441MHz)

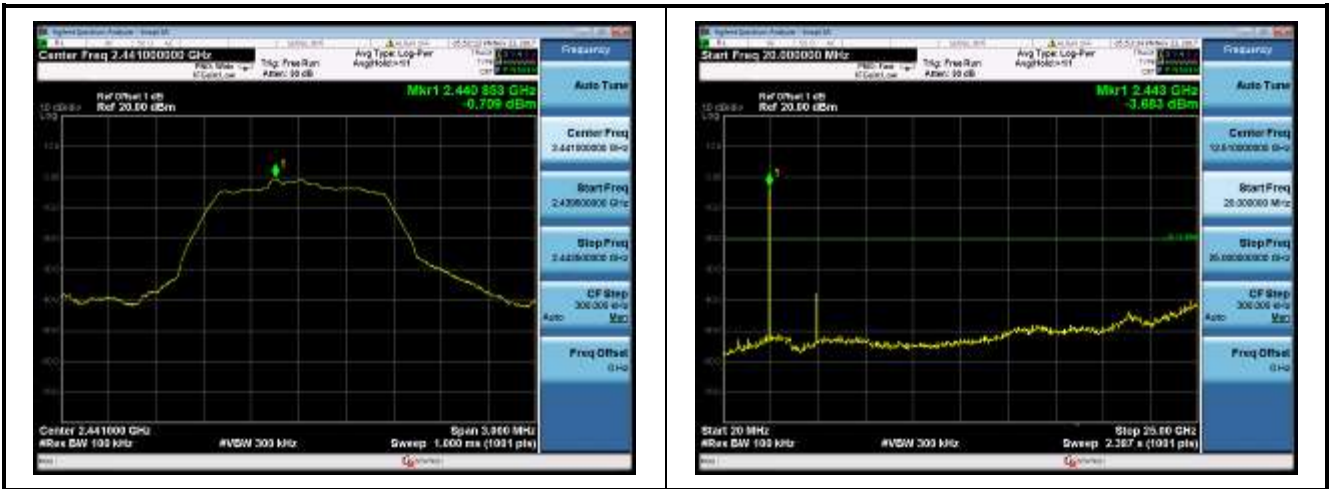

Mode 2: Transmit by 2DH5 (2480MHz)

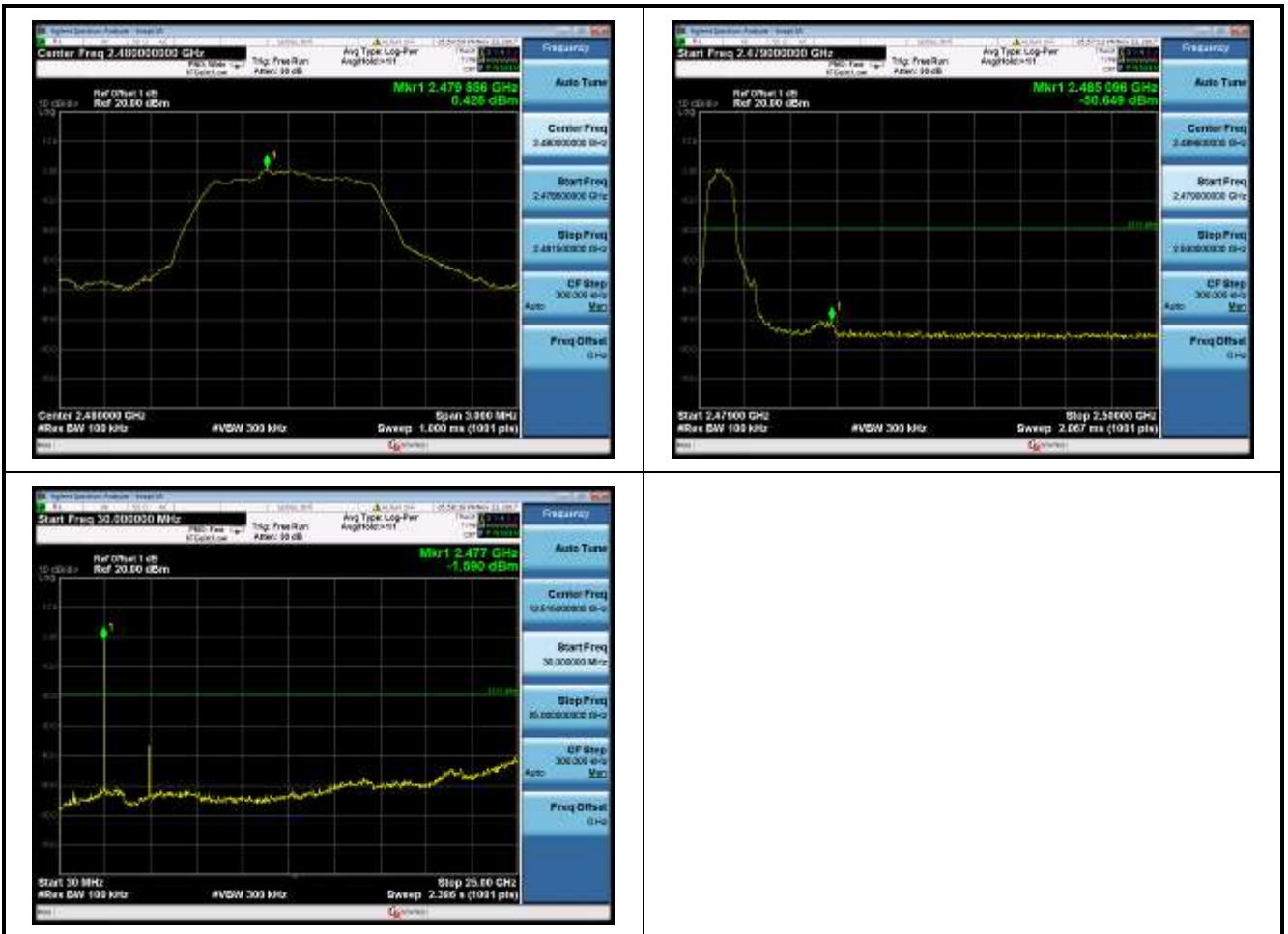



Test Item	:	Conducted Spurious Emissions
Test Mode	:	Mode 3: Transmitter 3DH5

Mode 3: Transmit by 3DH5 (2402MHz)





Mode 3: Transmit by 3DH5 (2441MHz)

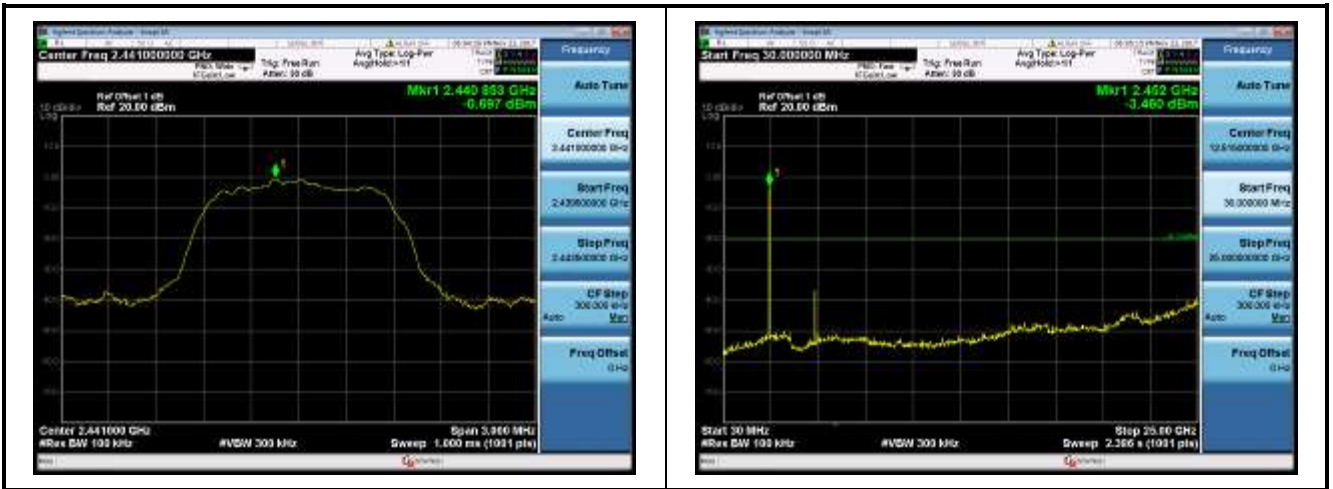

Mode 3: Transmit by 3DH5 (2480MHz)





Mode 1: Transmitter at DH5 by Hopping Mode

Low Frequency

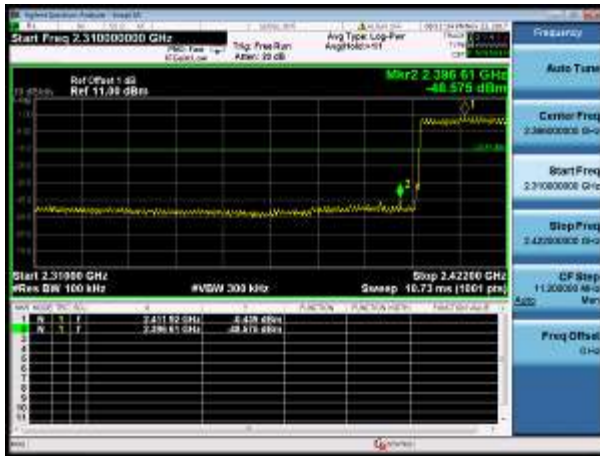

High Frequency

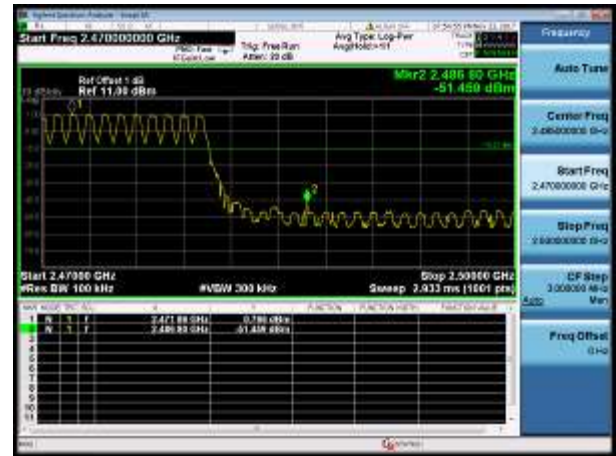

Mode 2: Transmitter at 2DH5 by Hopping Mode

Low Frequency

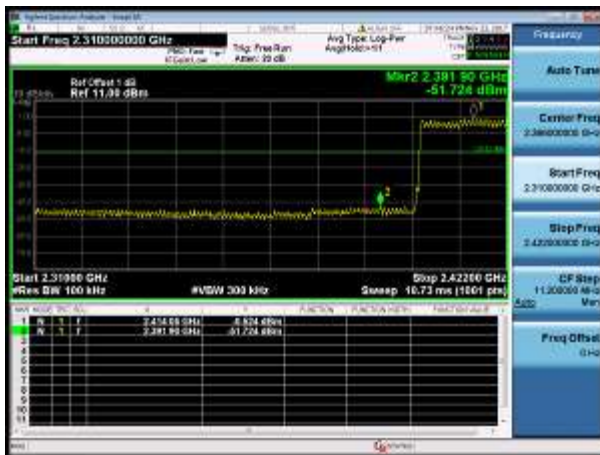

High Frequency





Mode 3: Transmitter at 3DH5 by Hopping Mode

Low Frequency



High Frequency

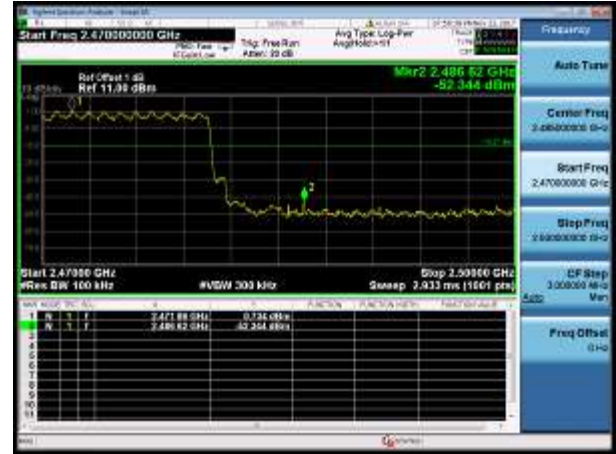



12. Radiated Emission Band Edge Measurement

12.1 Limit

Radiated emissions which fall in the restricted bands, as defined in Section 15.205(a) of FCC part 15, must also comply with the radiated emission limits specified in Section 15.209(a) of FCC part 15.

12.2 Test Procedure

According to ANSI C63.10: 2013.

This test is required for any spurious emission or modulation product that falls in a Restricted Band, as defined in Section 15.205 of FCC part 15. It must be performed with the highest gain of each type of antenna proposed for use with the EUT. Use the following spectrum analyzer settings:

Span = wide enough to fully capture the emission being measured

RBW = 1 MHz for $f \geq 1$ GHz, 100 kHz for $f < 1$ GHz

VBW \geq RBW

Sweep = auto

Detector function = peak

Trace = max hold

Follow the guidelines in ANSI C63.10 with respect to maximizing the emission by rotating the EUT, measuring the emission while the EUT is situated in three orthogonal planes (if appropriate), adjusting the measurement antenna height and polarization, etc. A pre-amp and a high pass filter are required for this test, in order to provide the measuring system with sufficient sensitivity. Allow the trace to stabilize. The peak reading of the emission, after being corrected by the antenna factor, cable loss, pre-amp gain, etc., is the peak field strength, which must comply with the limit specified in Section 15.35(b) of FCC part 15.

Now set the VBW to 10 Hz, while maintaining all of the other instrument settings. This peak level, once corrected, must comply with the limit specified in Section 15.209 of FCC Part 15. If the dwell time per channel of the hopping signal is less than 100 ms, then the reading obtained with the 10 Hz VBW may be further adjusted by a "duty cycle correction factor", derived from $20\log(\text{dwell time}/100 \text{ ms})$, in an effort to demonstrate compliance with the 15.209 limit of FCC part 15.

If the emission on which a radiated measurement must be made is located at the edge of the authorized band of operation, then the alternative "marker-delta" method may be employed.



12.3 Test Setup

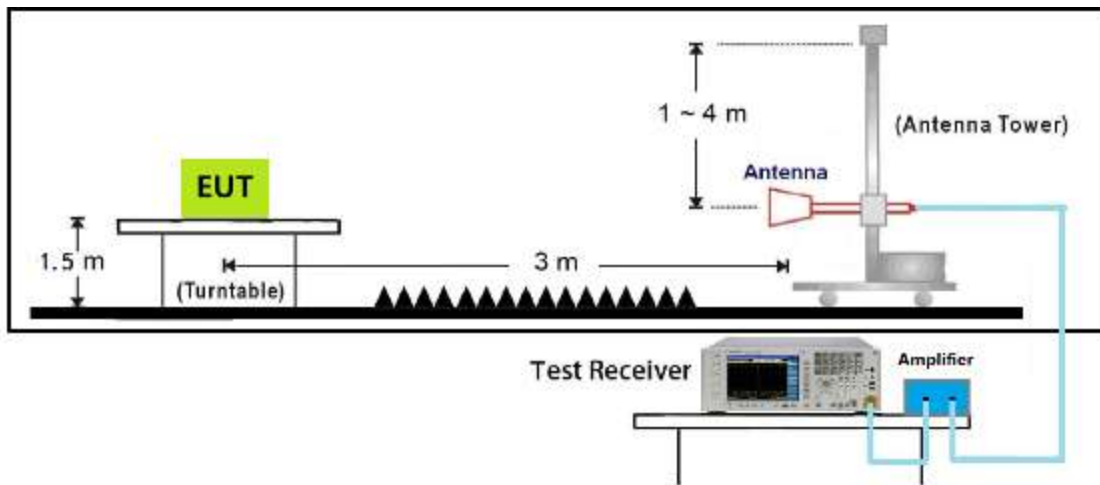



12.4 Test Result

Site: AC102	Time: 2017/11/25 - 20:22
Limit: FCC_Part15.209_RE(3m)	Margin: 0
Probe: N/A	Polarity: Horizontal
EUT: Bluetooth® Speaker Charger	Power: AC 120V/60Hz
Note: Mode:Transmit DH5 at 2402MHz	

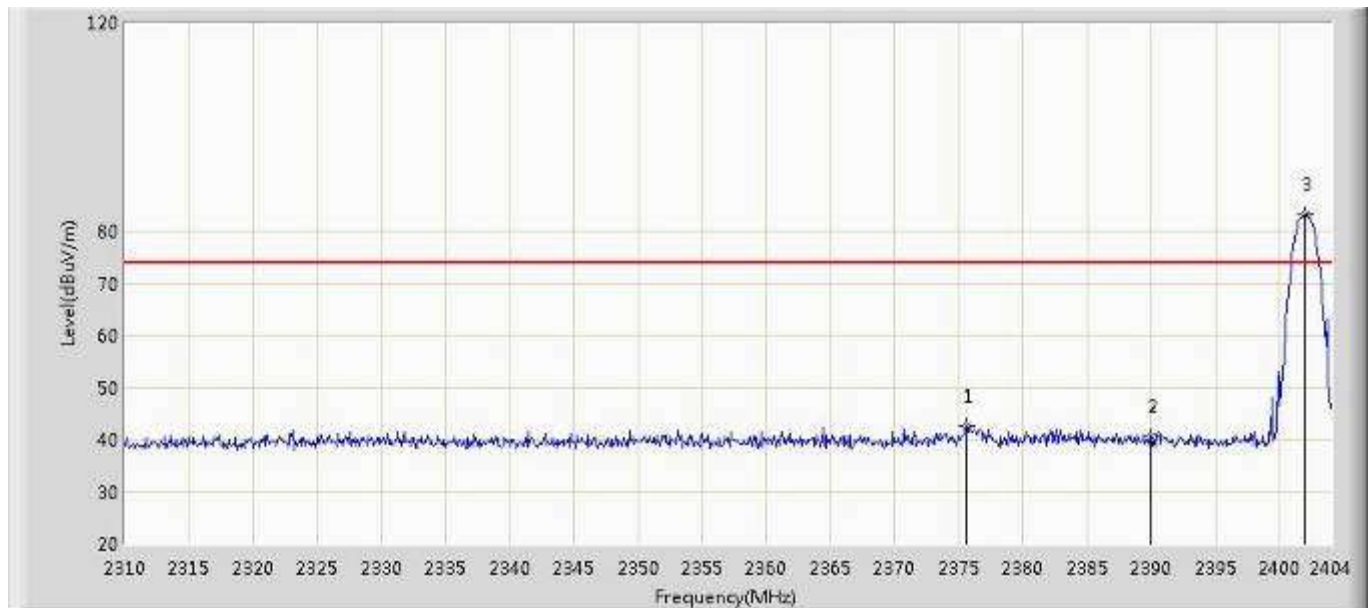

No	Mark	Frequency (MHz)	Measure Level (dBµV/m)	Reading Level (dBµV)	Over Limit (dB)	Limit (dBµV/m)	Factor (dB)	Type
1		2375.612	42.540	44.835	-31.460	74.000	-2.295	PK
2		2390.000	40.663	42.904	-33.337	74.000	-2.241	PK
3	*	2402.026	83.080	85.276	N/A	N/A	-2.196	PK

Note: Measure Level (dBµV/m) = Reading Level (dBµV) + Factor (dB)

Factor (dB) = Cable Loss (dB) + Antenna Factor (dB/m).



Site: AC102	Time: 2017/11/25 - 20:28
Limit: FCC_Part15.209_RE(3m)	Margin: 0
Probe: N/A	Polarity: Horizontal
EUT: Bluetooth® Speaker Charger	Power: AC 120V/60Hz
Note: Mode:Transmit DH5 at 2402MHz	

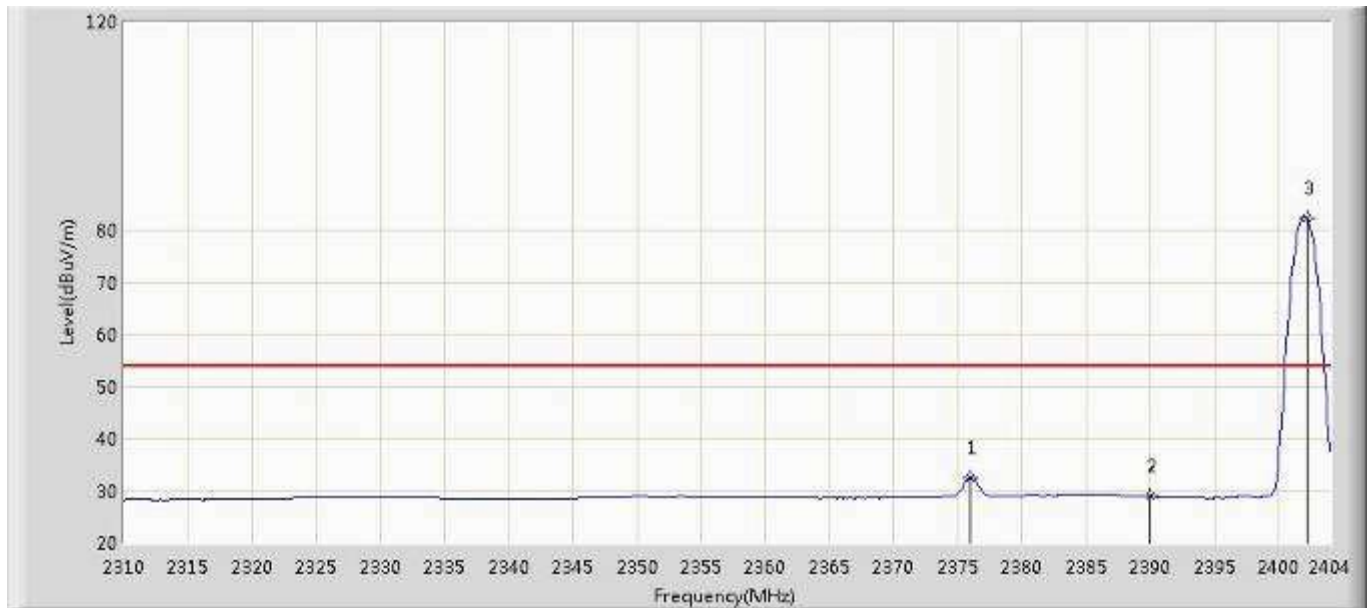

No	Mark	Frequency (MHz)	Measure Level (dBµV/m)	Reading Level (dBµV)	Over Limit (dB)	Limit (dBµV/m)	Factor (dB)	Type
1		2375.988	32.584	34.878	-21.416	54.000	-2.294	AV
2		2390.000	28.926	31.167	-25.074	54.000	-2.241	AV
3	*	2402.214	82.353	84.549	N/A	N/A	-2.196	AV

Note: Measure Level (dBµV/m) = Reading Level (dBµV) + Factor (dB)

Factor (dB) = Cable Loss (dB) + Antenna Factor (dB/m).



Site: AC102	Time: 2017/11/25 - 20:31
Limit: FCC_Part15.209_RE(3m)	Margin: 0
Probe: N/A	Polarity: Vertical
EUT: Bluetooth® Speaker Charger	Power: AC 120V/60Hz
Note: Mode:Transmit DH5 at 2402MHz	

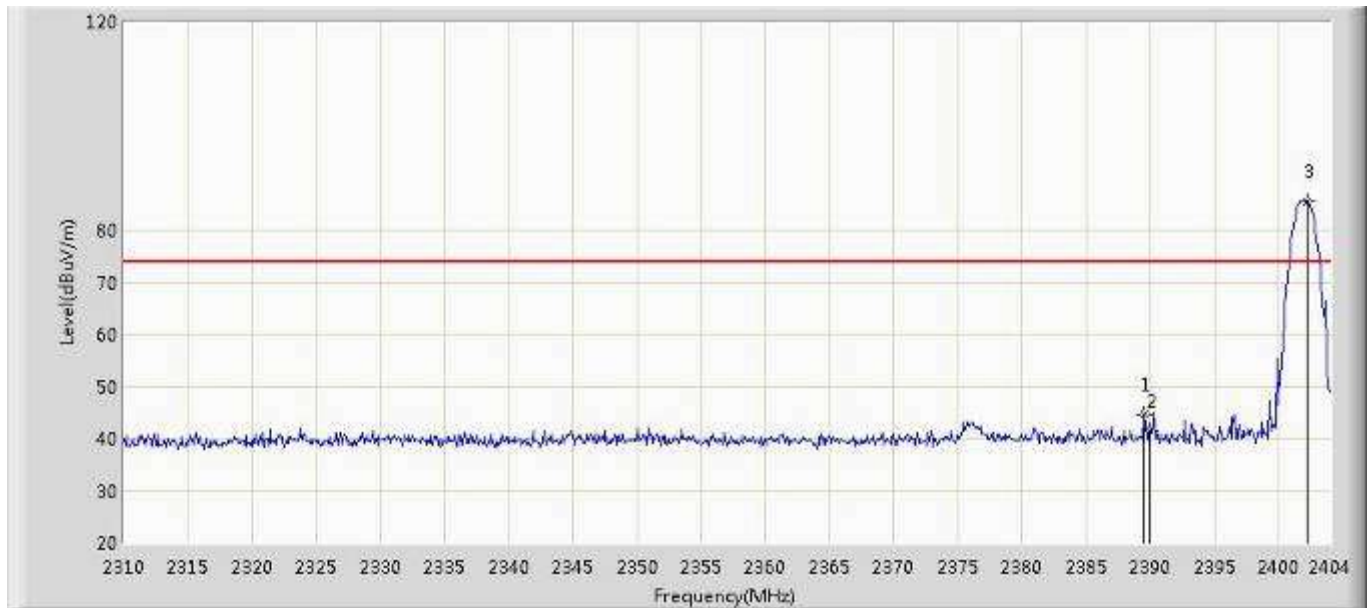

No	Mark	Frequency (MHz)	Measure Level (dBµV/m)	Reading Level (dBµV)	Over Limit (dB)	Limit (dBµV/m)	Factor (dB)	Type
1		2389.524	44.597	46.840	-29.403	74.000	-2.243	PK
2		2390.000	41.360	43.601	-32.640	74.000	-2.241	PK
3	*	2402.214	85.577	87.773	N/A	N/A	-2.196	PK

Note: Measure Level (dBµV/m) = Reading Level (dBµV) + Factor (dB)

Factor (dB) = Cable Loss (dB) + Antenna Factor (dB/m).



Site: AC102	Time: 2017/11/25 - 20:35
Limit: FCC_Part15.209_RE(3m)	Margin: 0
Probe: N/A	Polarity: Vertical
EUT: Bluetooth® Speaker Charger	Power: AC 120V/60Hz
Note: Mode:Transmit DH5 at 2402MHz	

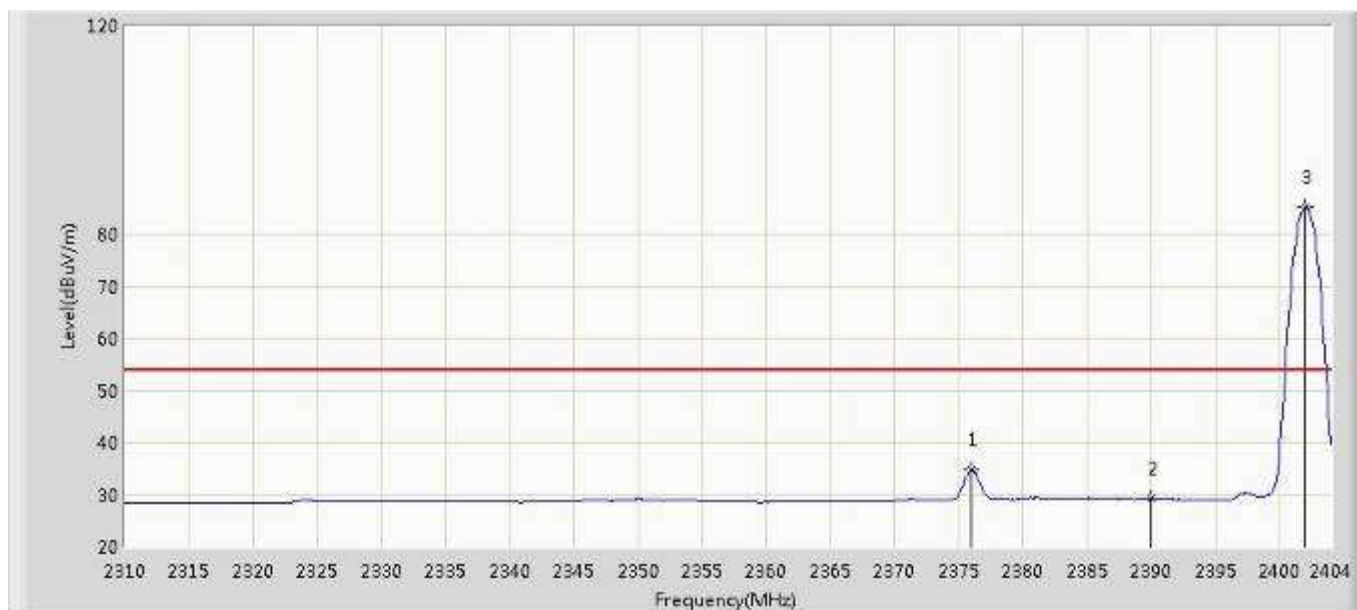

No	Mark	Frequency (MHz)	Measure Level (dBµV/m)	Reading Level (dBµV)	Over Limit (dB)	Limit (dBµV/m)	Factor (dB)	Type
1		2375.988	34.665	36.959	-19.335	54.000	-2.294	AV
2		2390.000	29.256	31.497	-24.744	54.000	-2.241	AV
3	*	2402.026	85.098	87.294	N/A	N/A	-2.196	AV

Note: Measure Level (dBµV/m) = Reading Level (dBµV) + Factor (dB)

Factor (dB) = Cable Loss (dB) + Antenna Factor (dB/m).



Site: AC102	Time: 2017/11/25 - 20:36
Limit: FCC_Part15.209_RE(3m)	Margin: 0
Probe: N/A	Polarity: Vertical
EUT: Bluetooth® Speaker Charger	Power: AC 120V/60Hz
Note: Mode:Transmit DH5 at 2480MHz	

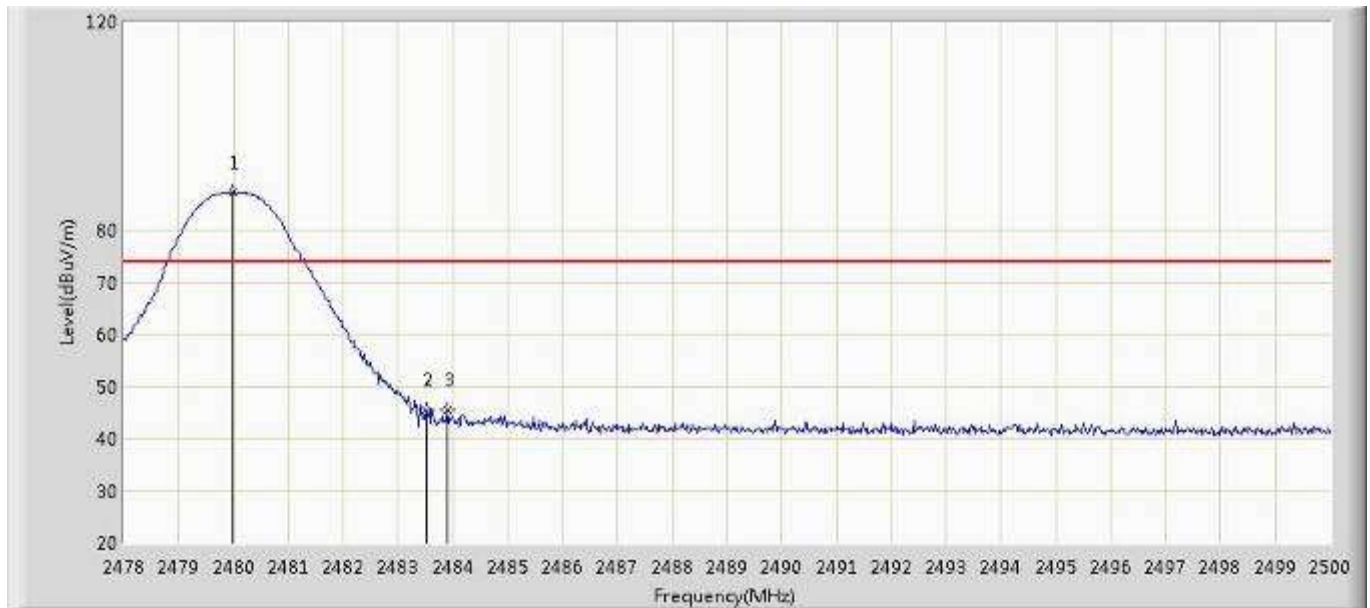

No	Mark	Frequency (MHz)	Measure Level (dBµV/m)	Reading Level (dBµV)	Over Limit (dB)	Limit (dBµV/m)	Factor (dB)	Type
1	*	2479.980	87.132	89.037	N/A	N/A	-1.905	PK
2		2483.500	45.468	47.360	-28.532	74.000	-1.892	PK
3		2483.896	45.634	47.525	-28.366	74.000	-1.891	PK

Note: Measure Level (dBµV/m) = Reading Level (dBµV) + Factor (dB)

Factor (dB) = Cable Loss (dB) + Antenna Factor (dB/m).



Site: AC102	Time: 2017/11/25 - 20:40
Limit: FCC_Part15.209_RE(3m)	Margin: 0
Probe: N/A	Polarity: Vertical
EUT: Bluetooth® Speaker Charger	Power: AC 120V/60Hz
Note: Mode:Transmit DH5 at 2480MHz	



No	Mark	Frequency (MHz)	Measure Level (dBµV/m)	Reading Level (dBµV)	Over Limit (dB)	Limit (dBµV/m)	Factor (dB)	Type
1	*	2480.024	86.662	88.567	N/A	N/A	-1.905	AV
2		2483.500	30.499	32.391	-23.501	54.000	-1.892	AV
3		2484.336	31.070	32.959	-22.930	54.000	-1.889	AV

Note: Measure Level (dBµV/m) = Reading Level (dBµV) + Factor (dB)

Factor (dB) = Cable Loss (dB) + Antenna Factor (dB/m).



Site: AC102	Time: 2017/11/25 - 20:40
Limit: FCC_Part15.209_RE(3m)	Margin: 0
Probe: N/A	Polarity: Horizontal
EUT: Bluetooth® Speaker Charger	Power: AC 120V/60Hz
Note: Mode:Transmit DH5 at 2480MHz	



No	Mark	Frequency (MHz)	Measure Level (dBµV/m)	Reading Level (dBµV)	Over Limit (dB)	Limit (dBµV/m)	Factor (dB)	Type
1	*	2480.024	83.020	84.925	N/A	N/A	-1.905	PK
2		2483.500	44.244	46.136	-29.756	74.000	-1.892	PK

Note: Measure Level (dBµV/m) = Reading Level (dBµV) + Factor (dB)

Factor (dB) = Cable Loss (dB) + Antenna Factor (dB/m).



Site: AC102	Time: 2017/11/25 - 20:44
Limit: FCC_Part15.209_RE(3m)	Margin: 0
Probe: N/A	Polarity: Horizontal
EUT: Bluetooth® Speaker Charger	Power: AC 120V/60Hz
Note: Mode:Transmit DH5 at 2480MHz	



No	Mark	Frequency (MHz)	Measure Level (dBµV/m)	Reading Level (dBµV)	Over Limit (dB)	Limit (dBµV/m)	Factor (dB)	Type
1	*	2480.024	82.575	84.480	N/A	N/A	-1.905	AV
2		2483.500	29.799	31.691	-24.201	54.000	-1.892	AV
3		2484.402	30.099	31.988	-23.901	54.000	-1.889	AV

Note: Measure Level (dBµV/m) = Reading Level (dBµV) + Factor (dB)

Factor (dB) = Cable Loss (dB) + Antenna Factor (dB/m).



Site: AC102	Time: 2017/11/25 - 20:44
Limit: FCC_Part15.209_RE(3m)	Margin: 0
Probe: N/A	Polarity: Horizontal
EUT: Bluetooth® Speaker Charger	Power: AC 120V/60Hz
Note: Mode:Transmit 2DH5 at 2402MHz	

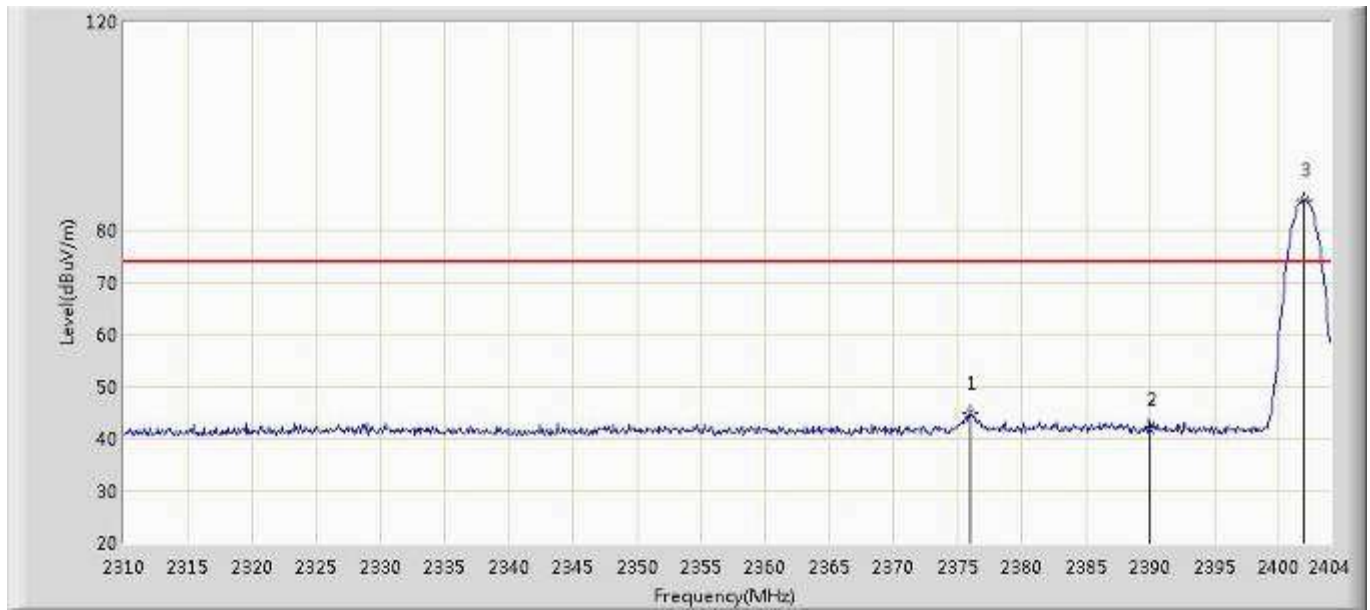

No	Mark	Frequency (MHz)	Measure Level (dBµV/m)	Reading Level (dBµV)	Over Limit (dB)	Limit (dBµV/m)	Factor (dB)	Type
1		2375.988	44.944	47.238	-29.056	74.000	-2.294	PK
2		2390.000	41.848	44.089	-32.152	74.000	-2.241	PK
3	*	2402.026	85.915	88.111	N/A	N/A	-2.196	PK

Note: Measure Level (dBµV/m) = Reading Level (dBµV) + Factor (dB)

Factor (dB) = Cable Loss (dB) + Antenna Factor (dB/m).



Site: AC102	Time: 2017/11/25 - 20:47
Limit: FCC_Part15.209_RE(3m)	Margin: 0
Probe: N/A	Polarity: Horizontal
EUT: Bluetooth® Speaker Charger	Power: AC 120V/60Hz
Note: Mode:Transmit 2DH5 at 2402MHz	



No	Mark	Frequency (MHz)	Measure Level (dBµV/m)	Reading Level (dBµV)	Over Limit (dB)	Limit (dBµV/m)	Factor (dB)	Type
1		2375.988	32.969	35.263	-21.031	54.000	-2.294	AV
2		2390.000	28.901	31.142	-25.099	54.000	-2.241	AV
3	*	2402.026	80.920	83.116	N/A	N/A	-2.196	AV

Note: Measure Level (dBµV/m) = Reading Level (dBµV) + Factor (dB)

Factor (dB) = Cable Loss (dB) + Antenna Factor (dB/m).



Site: AC102	Time: 2017/11/25 - 20:47
Limit: FCC_Part15.209_RE(3m)	Margin: 0
Probe: N/A	Polarity: Vertical
EUT: Bluetooth® Speaker Charger	Power: AC 120V/60Hz
Note: Mode:Transmit 2DH5 at 2402MHz	

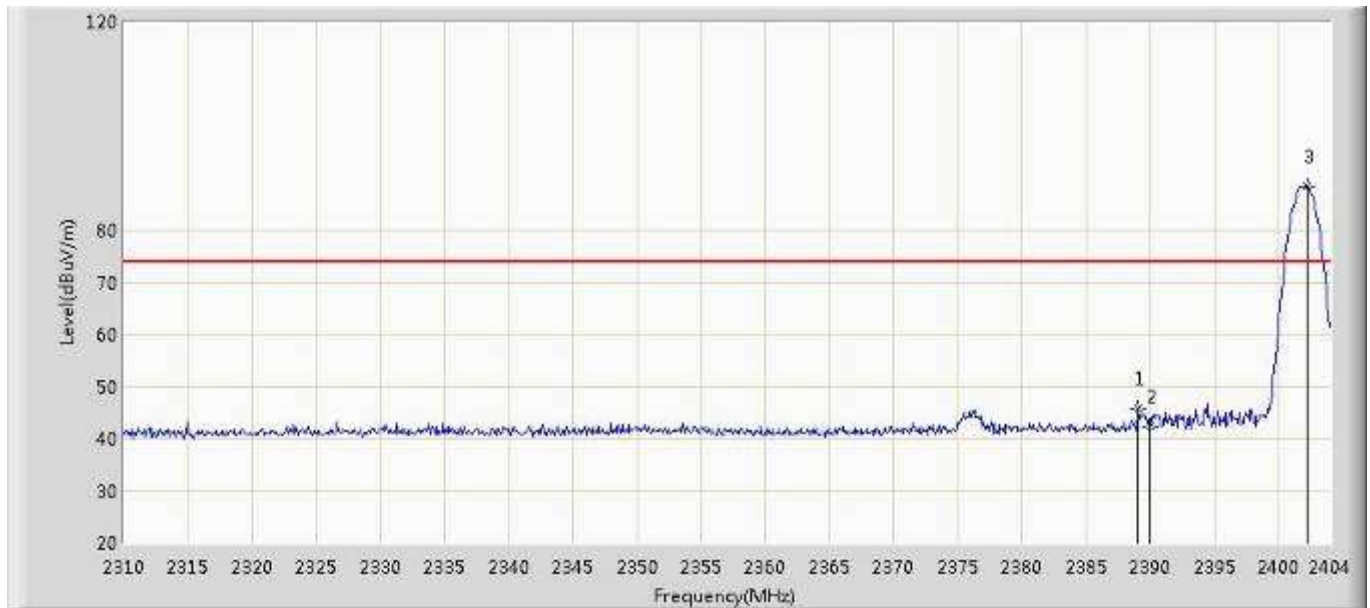

No	Mark	Frequency (MHz)	Measure Level (dBµV/m)	Reading Level (dBµV)	Over Limit (dB)	Limit (dBµV/m)	Factor (dB)	Type
1		2389.054	45.869	48.114	-28.131	74.000	-2.245	PK
2		2390.000	42.178	44.419	-31.822	74.000	-2.241	PK
3	*	2402.214	88.481	90.677	N/A	N/A	-2.196	PK

Note: Measure Level (dBµV/m) = Reading Level (dBµV) + Factor (dB)

Factor (dB) = Cable Loss (dB) + Antenna Factor (dB/m).



Site: AC102	Time: 2017/11/25 - 20:50
Limit: FCC_Part15.209_RE(3m)	Margin: 0
Probe: N/A	Polarity: Vertical
EUT: Bluetooth® Speaker Charger	Power: AC 120V/60Hz
Note: Mode:Transmit 2DH5 at 2402MHz	

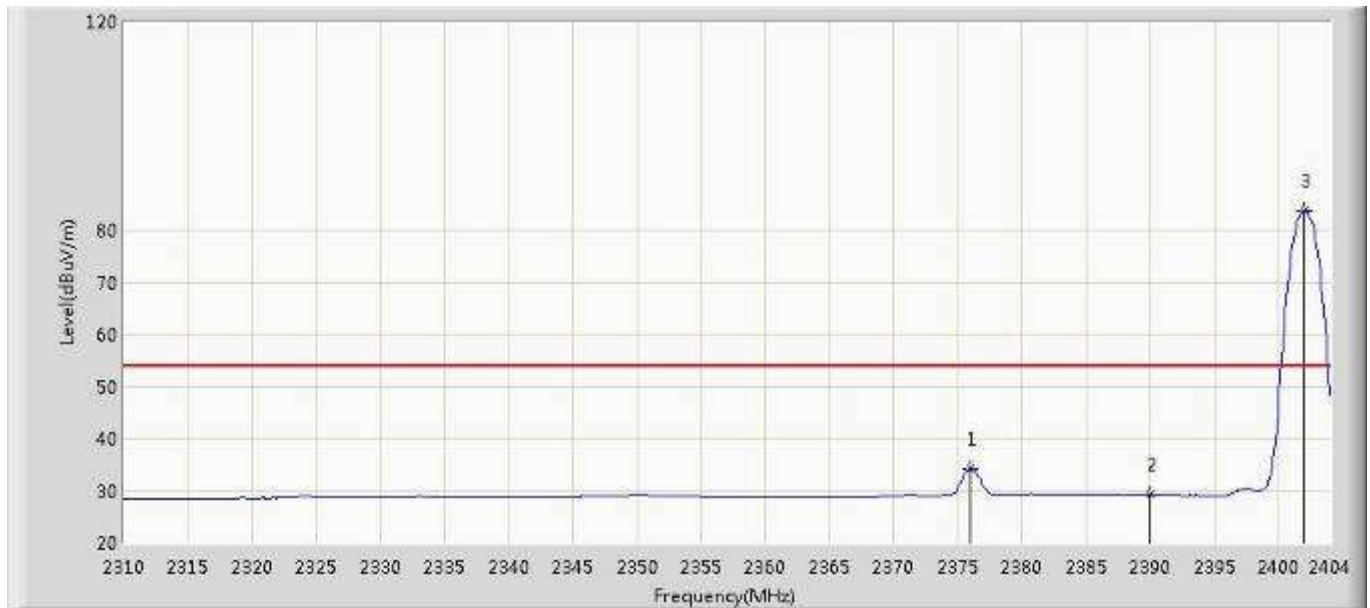

No	Mark	Frequency (MHz)	Measure Level (dBµV/m)	Reading Level (dBµV)	Over Limit (dB)	Limit (dBµV/m)	Factor (dB)	Type
1		2375.988	34.178	36.472	-19.822	54.000	-2.294	AV
2		2390.000	29.322	31.563	-24.678	54.000	-2.241	AV
3	*	2402.026	83.895	86.091	N/A	N/A	-2.196	AV

Note: Measure Level (dBµV/m) = Reading Level (dBµV) + Factor (dB)

Factor (dB) = Cable Loss (dB) + Antenna Factor (dB/m).



Site: AC102	Time: 2017/11/25 - 20:50
Limit: FCC_Part15.209_RE(3m)	Margin: 0
Probe: N/A	Polarity: Vertical
EUT: Bluetooth® Speaker Charger	Power: AC 120V/60Hz
Note: Mode:Transmit 2DH5 at 2480MHz	



No	Mark	Frequency (MHz)	Measure Level (dBµV/m)	Reading Level (dBµV)	Over Limit (dB)	Limit (dBµV/m)	Factor (dB)	Type
1	*	2480.024	90.086	91.991	N/A	N/A	-1.905	PK
2		2483.500	42.783	44.675	-31.217	74.000	-1.892	PK
3		2491.222	45.419	47.282	-28.581	74.000	-1.863	PK

Note: Measure Level (dBµV/m) = Reading Level (dBµV) + Factor (dB)

Factor (dB) = Cable Loss (dB) + Antenna Factor (dB/m).



Site: AC102	Time: 2017/11/25 - 20:54
Limit: FCC_Part15.209_RE(3m)	Margin: 0
Probe: N/A	Polarity: Vertical
EUT: Bluetooth® Speaker Charger	Power: AC 120V/60Hz
Note: Mode:Transmit 2DH5 at 2480MHz	



No	Mark	Frequency (MHz)	Measure Level (dBµV/m)	Reading Level (dBµV)	Over Limit (dB)	Limit (dBµV/m)	Factor (dB)	Type
1	*	2479.980	85.592	87.497	N/A	N/A	-1.905	AV
2		2483.500	30.934	32.826	-23.066	54.000	-1.892	AV
3		2484.292	31.345	33.234	-22.655	54.000	-1.889	AV

Note: Measure Level (dBµV/m) = Reading Level (dBµV) + Factor (dB)

Factor (dB) = Cable Loss (dB) + Antenna Factor (dB/m).



Site: AC102	Time: 2017/11/25 - 20:55
Limit: FCC_Part15.209_RE(3m)	Margin: 0
Probe: N/A	Polarity: Horizontal
EUT: Bluetooth® Speaker Charger	Power: AC 120V/60Hz
Note: Mode:Transmit 2DH5 at 2480MHz	

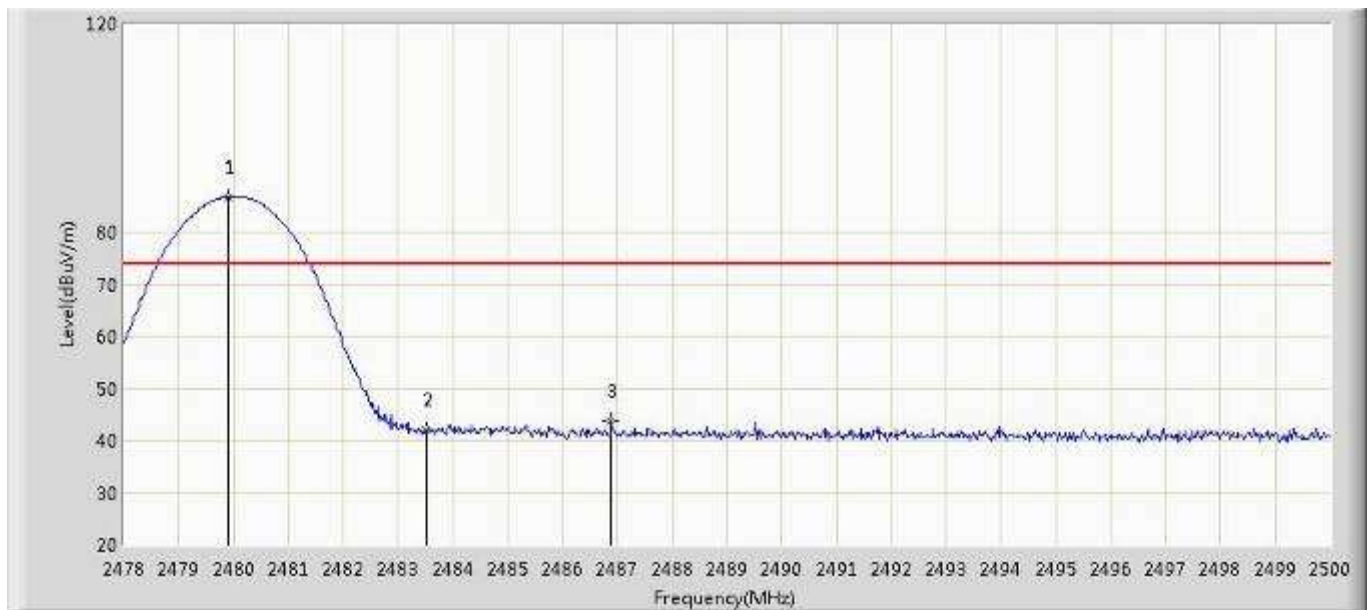

No	Mark	Frequency (MHz)	Measure Level (dBµV/m)	Reading Level (dBµV)	Over Limit (dB)	Limit (dBµV/m)	Factor (dB)	Type
1	*	2479.914	86.660	88.566	N/A	N/A	-1.906	PK
2		2483.500	41.888	43.780	-32.112	74.000	-1.892	PK
3		2486.888	43.809	45.688	-30.191	74.000	-1.879	PK

Note: Measure Level (dBµV/m) = Reading Level (dBµV) + Factor (dB)

Factor (dB) = Cable Loss (dB) + Antenna Factor (dB/m).



Site: AC102	Time: 2017/11/25 - 20:58
Limit: FCC_Part15.209_RE(3m)	Margin: 0
Probe: N/A	Polarity: Horizontal
EUT: Bluetooth® Speaker Charger	Power: AC 120V/60Hz
Note: Mode:Transmit 2DH5 at 2480MHz	



No	Mark	Frequency (MHz)	Measure Level (dBµV/m)	Reading Level (dBµV)	Over Limit (dB)	Limit (dBµV/m)	Factor (dB)	Type
1	*	2480.024	82.105	84.010	N/A	N/A	-1.905	AV
2		2483.500	29.974	31.866	-24.026	54.000	-1.892	AV
3		2484.402	30.128	32.017	-23.872	54.000	-1.889	AV

Note: Measure Level (dBµV/m) = Reading Level (dBµV) + Factor (dB)

Factor (dB) = Cable Loss (dB) + Antenna Factor (dB/m).



Site: AC102	Time: 2017/11/25 - 20:58
Limit: FCC_Part15.209_RE(3m)	Margin: 0
Probe: N/A	Polarity: Horizontal
EUT: Bluetooth® Speaker Charger	Power: AC 120V/60Hz
Note: Mode:Transmit 3DH5 at 2402MHz	

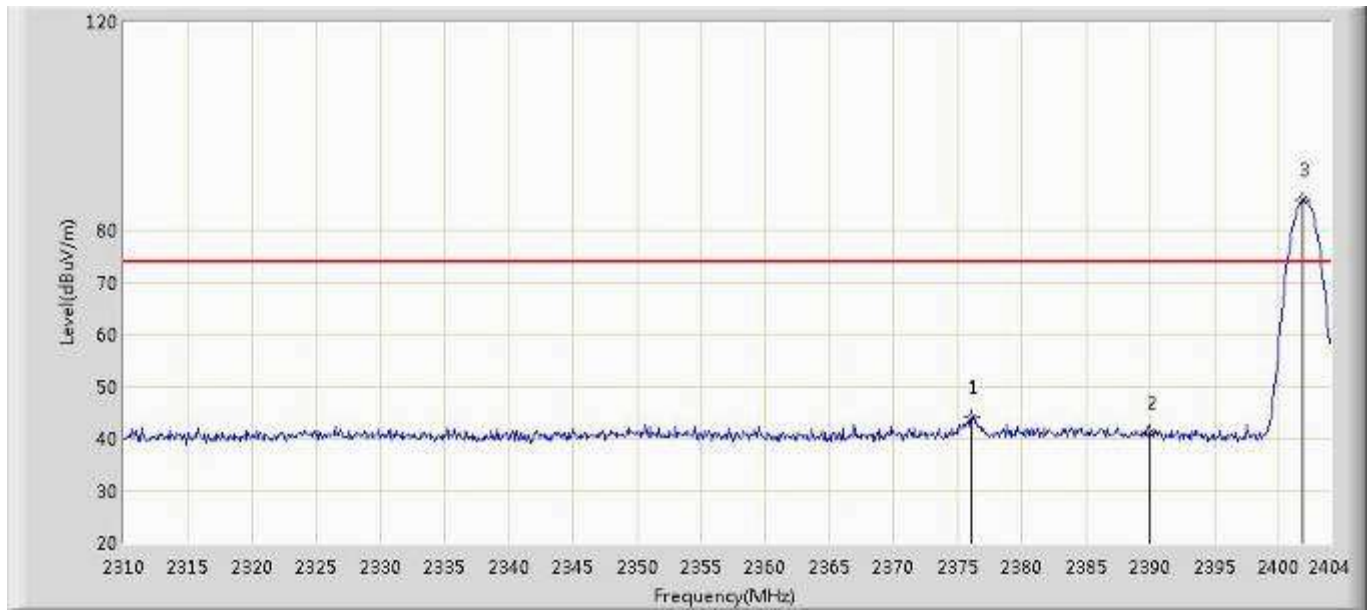

No	Mark	Frequency (MHz)	Measure Level (dBµV/m)	Reading Level (dBµV)	Over Limit (dB)	Limit (dBµV/m)	Factor (dB)	Type
1		2376.082	44.138	46.431	-29.862	74.000	-2.293	PK
2		2390.000	41.201	43.442	-32.799	74.000	-2.241	PK
3	*	2401.932	85.909	88.106	N/A	N/A	-2.197	PK

Note: Measure Level (dBµV/m) = Reading Level (dBµV) + Factor (dB)

Factor (dB) = Cable Loss (dB) + Antenna Factor (dB/m).



Site: AC102	Time: 2017/11/25 - 21:00
Limit: FCC_Part15.209_RE(3m)	Margin: 0
Probe: N/A	Polarity: Horizontal
EUT: Bluetooth® Speaker Charger	Power: AC 120V/60Hz
Note: Mode:Transmit 3DH5 at 2402MHz	



No	Mark	Frequency (MHz)	Measure Level (dBµV/m)	Reading Level (dBµV)	Over Limit (dB)	Limit (dBµV/m)	Factor (dB)	Type
1		2375.988	32.732	35.026	-21.268	54.000	-2.294	AV
2		2390.000	28.930	31.171	-25.070	54.000	-2.241	AV
3	*	2402.026	80.461	82.657	N/A	N/A	-2.196	AV

Note: Measure Level (dBµV/m) = Reading Level (dBµV) + Factor (dB)

Factor (dB) = Cable Loss (dB) + Antenna Factor (dB/m).



Site: AC102	Time: 2017/11/25 - 21:01
Limit: FCC_Part15.209_RE(3m)	Margin: 0
Probe: N/A	Polarity: Vertical
EUT: Bluetooth® Speaker Charger	Power: AC 120V/60Hz
Note: Mode:Transmit 3DH5 at 2402MHz	

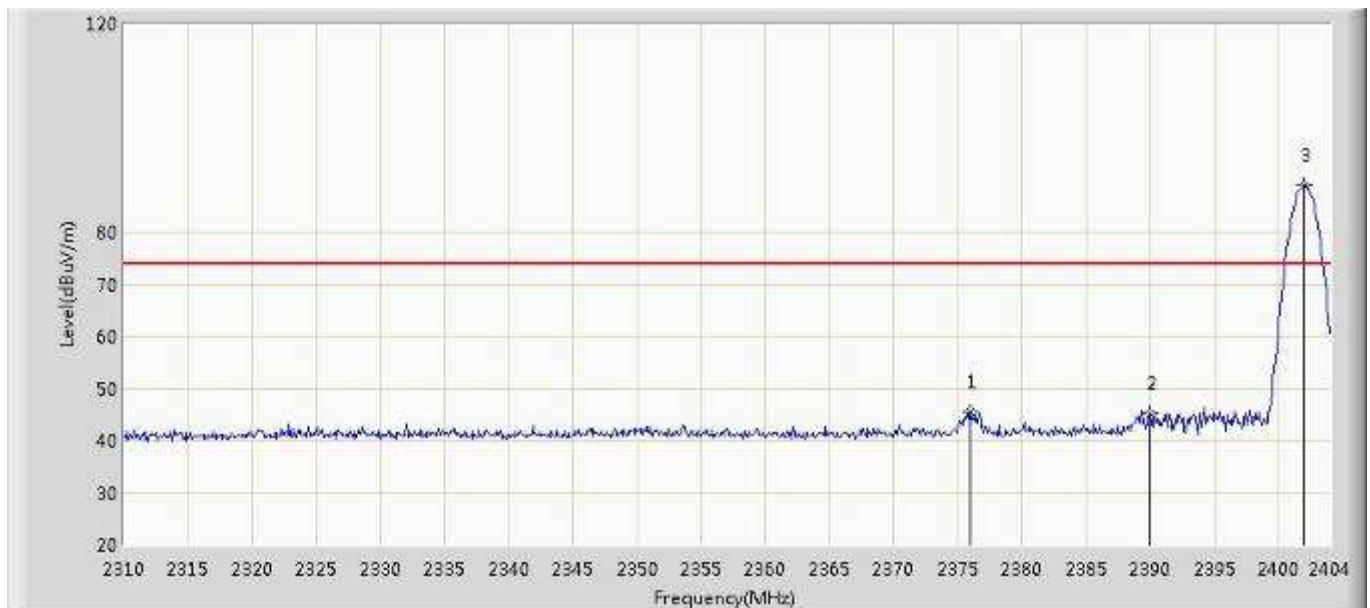

No	Mark	Frequency (MHz)	Measure Level (dBµV/m)	Reading Level (dBµV)	Over Limit (dB)	Limit (dBµV/m)	Factor (dB)	Type
1		2375.988	45.399	47.693	-28.601	74.000	-2.294	PK
2		2390.000	45.098	47.339	-28.902	74.000	-2.241	PK
3	*	2402.026	89.026	91.222	N/A	N/A	-2.196	PK

Note: Measure Level (dBµV/m) = Reading Level (dBµV) + Factor (dB)

Factor (dB) = Cable Loss (dB) + Antenna Factor (dB/m).



Site: AC102	Time: 2017/11/25 - 21:04
Limit: FCC_Part15.209_RE(3m)	Margin: 0
Probe: N/A	Polarity: Vertical
EUT: Bluetooth® Speaker Charger	Power: AC 120V/60Hz
Note: Mode:Transmit 3DH5 at 2402MHz	

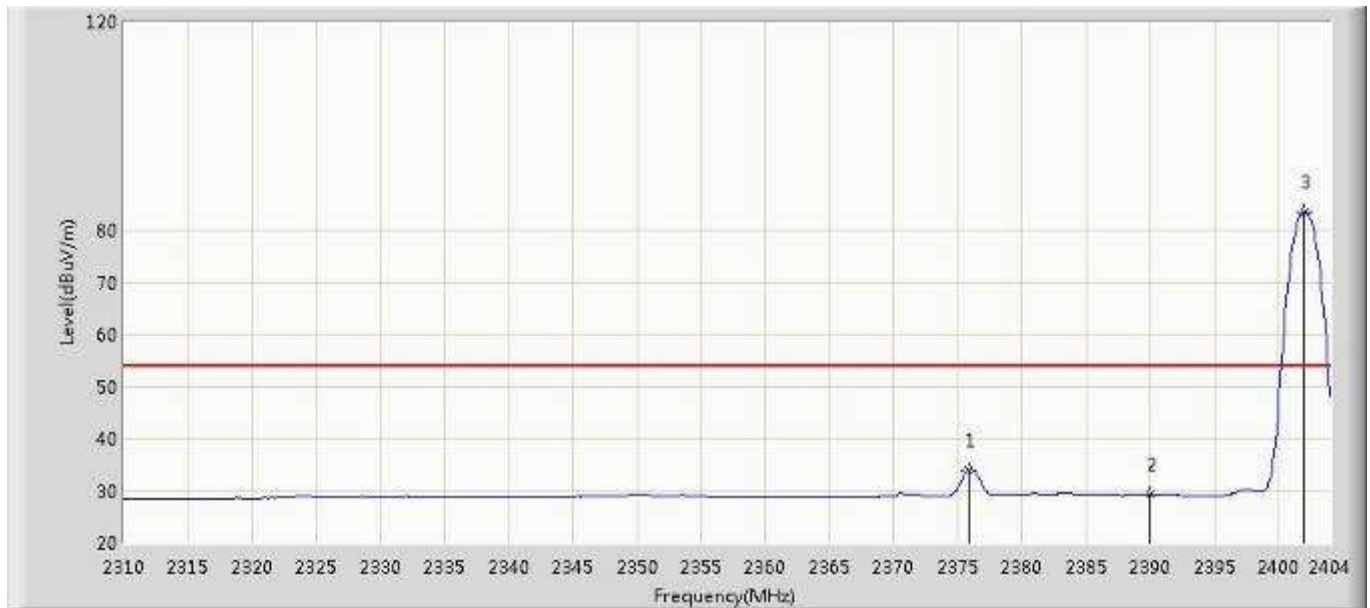

No	Mark	Frequency (MHz)	Measure Level (dBµV/m)	Reading Level (dBµV)	Over Limit (dB)	Limit (dBµV/m)	Factor (dB)	Type
1		2375.894	34.043	36.337	-19.957	54.000	-2.294	AV
2		2390.000	29.256	31.497	-24.744	54.000	-2.241	AV
3	*	2402.026	83.577	85.773	N/A	N/A	-2.196	AV

Note: Measure Level (dBµV/m) = Reading Level (dBµV) + Factor (dB)

Factor (dB) = Cable Loss (dB) + Antenna Factor (dB/m).



Site: AC102	Time: 2017/11/25 - 21:05
Limit: FCC_Part15.209_RE(3m)	Margin: 0
Probe: N/A	Polarity: Vertical
EUT: Bluetooth® Speaker Charger	Power: AC 120V/60Hz
Note: Mode:Transmit 3DH5 at 2480MHz	

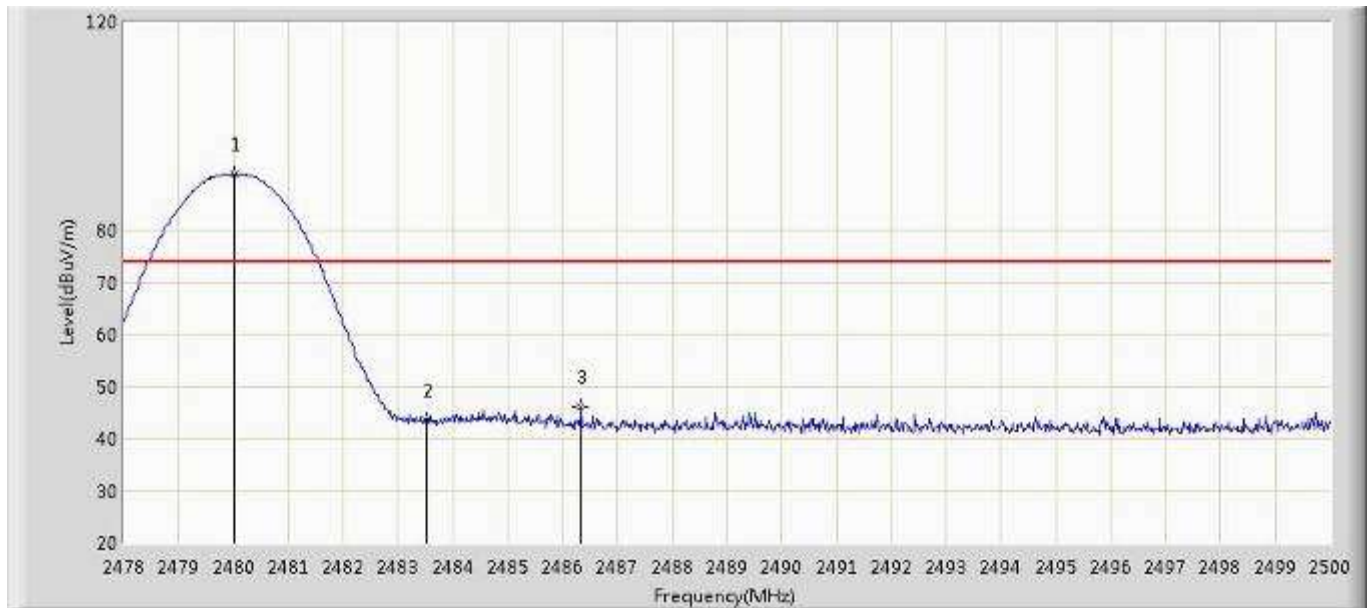

No	Mark	Frequency (MHz)	Measure Level (dBµV/m)	Reading Level (dBµV)	Over Limit (dB)	Limit (dBµV/m)	Factor (dB)	Type
1	*	2480.024	90.834	92.739	N/A	N/A	-1.905	PK
2		2483.500	43.429	45.321	-30.571	74.000	-1.892	PK
3		2486.338	46.190	48.071	-27.810	74.000	-1.881	PK

Note: Measure Level (dBµV/m) = Reading Level (dBµV) + Factor (dB)

Factor (dB) = Cable Loss (dB) + Antenna Factor (dB/m).



Site: AC102	Time: 2017/11/25 - 21:06
Limit: FCC_Part15.209_RE(3m)	Margin: 0
Probe: N/A	Polarity: Vertical
EUT: Bluetooth® Speaker Charger	Power: AC 120V/60Hz
Note: Mode:Transmit 3DH5 at 2480MHz	



No	Mark	Frequency (MHz)	Measure Level (dBµV/m)	Reading Level (dBµV)	Over Limit (dB)	Limit (dBµV/m)	Factor (dB)	Type
1	*	2480.024	85.742	87.647	N/A	N/A	-1.905	AV
2		2483.500	30.880	32.772	-23.120	54.000	-1.892	AV
3		2484.226	31.405	33.294	-22.595	54.000	-1.889	AV

Note: Measure Level (dBµV/m) = Reading Level (dBµV) + Factor (dB)

Factor (dB) = Cable Loss (dB) + Antenna Factor (dB/m).



Site: AC102	Time: 2017/11/25 - 21:07
Limit: FCC_Part15.209_RE(3m)	Margin: 0
Probe: N/A	Polarity: Horizontal
EUT: Bluetooth® Speaker Charger	Power: AC 120V/60Hz
Note: Mode:Transmit 3DH5 at 2480MHz	

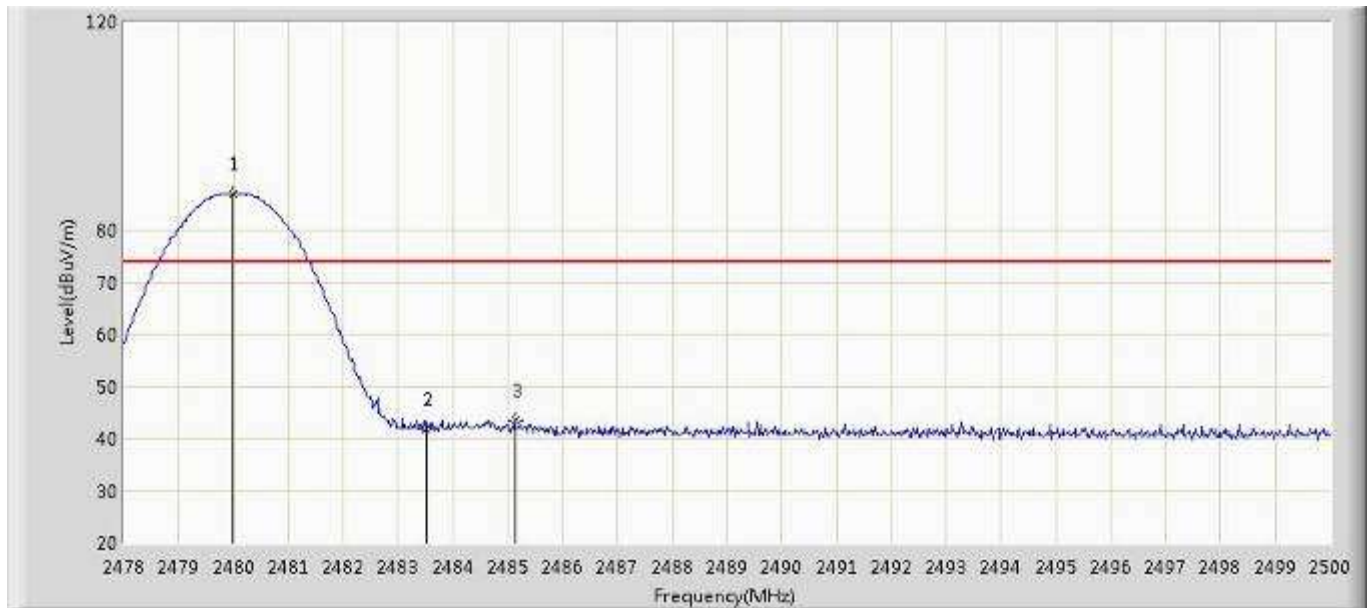

No	Mark	Frequency (MHz)	Measure Level (dBµV/m)	Reading Level (dBµV)	Over Limit (dB)	Limit (dBµV/m)	Factor (dB)	Type
1	*	2479.980	87.084	88.989	N/A	N/A	-1.905	PK
2		2483.500	41.695	43.587	-32.305	74.000	-1.892	PK
3		2485.128	43.605	45.491	-30.395	74.000	-1.886	PK

Note: Measure Level (dBµV/m) = Reading Level (dBµV) + Factor (dB)

Factor (dB) = Cable Loss (dB) + Antenna Factor (dB/m).



Site: AC102	Time: 2017/11/25 - 21:09
Limit: FCC_Part15.209_RE(3m)	Margin: 0
Probe: N/A	Polarity: Horizontal
EUT: Bluetooth® Speaker Charger	Power: AC 120V/60Hz
Note: Mode:Transmit 3DH5 at 2480MHz	



No	Mark	Frequency (MHz)	Measure Level (dBµV/m)	Reading Level (dBµV)	Over Limit (dB)	Limit (dBµV/m)	Factor (dB)	Type
1	*	2480.024	82.055	83.960	N/A	N/A	-1.905	AV
2		2483.500	30.119	32.011	-23.881	54.000	-1.892	AV
3		2484.578	30.390	32.278	-23.610	54.000	-1.888	AV

Note: Measure Level (dBµV/m) = Reading Level (dBµV) + Factor (dB)

Factor (dB) = Cable Loss (dB) + Antenna Factor (dB/m).

The End