

FCC TEST REPORT

FCC ID: 2AN8FMSL-W186

Product Name:	2500 mAh Suction Wireless Power Bank
Trademark:	N/A
Model Number:	MSL-W186
Prepared For :	ShenZhen Mossloo Industrial CO., Ltd
Address :	Road One No.4, Science Industrial Park, Shangxue Village, Bantian Street, Longgang District, Shenzhen, China
Prepared By :	Shenzhen BCTC Testing Co., Ltd.
Address :	BCTC Building & 1-2F, East of B Building, Pengzhou Industrial, Fuyuan 1st Road, Qiaotou Community, Fuyong Street, Bao'an District, Shenzhen, China
Test Date:	Mar. 18, 2019 - Mar. 26, 2019
Date of Report :	Mar. 26, 2019
Report No.:	BCTC-FY190301087E

TABLE OF CONTENTS

TEST REPORT DECLARATION	3
1.GENERAL INFORMATION	4
1.1. Report information	4
1.2. Measurement Uncertainty.....	4
1.3. Test Facility.....	4
1.4. Test Uncertainty	4
2.PRODUCT DESCRIPTION.....	5
2.1. EUT Description	5
2.2. Test mode	5
2.3. Block Diagram of EUT Configuration.....	5
2.4. Test Conditions.....	5
2.5. Description Of Support Units (Conducted Mode).....	6
3.TEST RESULTS SUMMARY	6
4. TEST EQUIPMENT USED.....	7
4.1. For Conducted Emission Test.....	7
4.2. For Radiated Emission Measurement	7
5.CONDUCTED EMISSION TEST.....	8
5.1. Block Diagram of Test Setup.....	8
5.2. Test Standard	8
5.3. Conducted Emission Limit	8
5.4. EUT Configuration on Test.....	8
5.5. Operating Condition of EUT	9
5.6. Test Procedure	9
5.7. Test Result.....	9
6.RADIATED EMISSION MEASUREMENT	12
6.1. Block Diagram of Test Setup.....	12
6.2. Test Standard and Limit.....	13
6.3. EMI Test Receiver Setup.....	14
6.4. Test Procedure	14
6.5. Test Result.....	14
7.EUT TEST PHOTOS.....	18
8.EUT PHOTOS.....	20

TEST REPORT DECLARATION

Applicant : Shenzhen Mossloo Industrial Co.,Ltd
Address : Road One No.4, Science Industrial Park, Shangxue Village, Bantian Street, Longgang District, Shenzhen, China
EUT Description : 2500 mAh Suction Wireless Power Bank
Model Number : MSL-W186

Test Standards: FCC Part 15 Subpart C, 15.209

This device described above has been tested by BCTC, and the test results show that the equipment under And it is applicable only to the tested sample identified in the report.

This report shall not be reproduced except in full, without the written approval of BCTC, this document may be altered or revised by BCTC, personal only, and shall be noted in the revision of the document.

Prepared by(Engineer): Cai Fang Zhong

Cai Fang Zhong

Reviewer(Supervisor): Eric Yang

Eric Yang

Approved(Manager): Carson Zhang



1. GENERAL INFORMATION

1.1. Report information

- 1.1.1. This report is not a certificate of quality; it only applies to the sample of the specific product/equipment given at the time of its testing. The results are not used to indicate or imply that they are application to the similar items. In addition, such results must not be used to indicate or imply that BCTC approves recommends or endorses the manufacture, supplier or use of such product/equipment, or that BCTC in any way guarantees the later performance of the product/equipment.
- 1.1.2. The sample/s mentioned in this report is/are supplied by Applicant, BCTC therefore assumes no responsibility for the accuracy of information on the brand name, model number, origin of manufacture or any information supplied.
- 1.1.3. Additional copies of the report are available to the Applicant at an additional fee. No third part can obtain a copy of this report through BCTC, unless the applicant has authorized BCTC in writing to do so.

1.2. Measurement Uncertainty

Available upon request.

1.3. Test Facility

Shenzhen BCTC Testing Co., Ltd.

Add.: BCTC Building & 1-2F, East of B Building, Pengzhou Industrial, Fuyuan 1st Road, Qiaotou Community, Fuyong Street, Bao'an District, Shenzhen, China

FCC Test Firm Registration Number: 712850

IC Registered No.: 23583

1.4. Test Uncertainty

Conducted Emission = $\pm 2.66\text{dB}$
Uncertainty
Radiated Emission Uncertainty = $\pm 4.15\text{dB}$

2. PRODUCT DESCRIPTION

2.1.EUT Description

Description	: 2500 mAh Suction Wireless Power Bank
Applicant	: Shenzhen Mossloo Industrial Co.,Ltd Road One No.4, Science Industrial Park, Shangxue Village, Bantian Street, Longgang District, Shenzhen, China
Manufacturer	: Shenzhen Mossloo Industrial Co.,Ltd Road One No.4, Science Industrial Park, Shangxue Village, Bantian Street, Longgang District, Shenzhen, China
Model Number	: MSL-W186
Serial Model	: N/A
Model Difference	: N/A
Power Supply	Input: 5V 2A Output: 5V 1A
Work Frequency	: 110-205KHz

2.2.Test mode

Test Modes	keeping TX+Charging mode
------------	--------------------------

2.3.Block Diagram of EUT Configuration

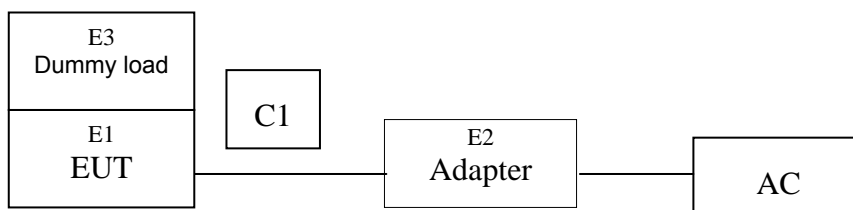

2.4.Test Conditions

Temperature: 23~26℃

Relative Humidity: 54~63 %

2.5. Description Of Support Units (Conducted Mode)

The EUT has been tested as an independent unit together with other necessary accessories or support units. The following support units or accessories were used to form a representative test configuration during the tests.

Item	Equipment	Mfr/Brand	Model/Type No.	Series No.	Note
E1	2500 mAh Suction Wireless Power Bank	N/A	MSL-W186	N/A	EUT
E2	Adapter	N/A	BCTC-002	N/A	AC100-240V~50/60Hz Output: 5V--- 2A
E3	Dummy load	N/A	DL01	N/A	N/A

Item	Shielded Type	Ferrite Core	Length	Note
C1	NO	NO	1.0M	DC cable unshielded

Note:

- (1) The support equipment was authorized by Declaration of Confirmation.
- (2) For detachable type I/O cable should be specified the length in cm in 『Length』 column.
- (3) "YES" is means "shielded" "with core"; "NO" is means "unshielded" "without core".

3. TEST RESULTS SUMMARY

Table 1 Test Results Summary

Standard Section	Test Items	Test Results
15.207	Conducted disturbance	Pass
15.209	Radiated disturbance	Pass

Remark: "N/A" means "Not applicable."

4. TEST EQUIPMENT USED

4.1. For Conducted Emission Test

Item	Equipment	Manufacturer	Type No.	Serial No.	Last calibration	Calibrated until
1	Test Receiver	R&S	ESR3	102075	2018.06.20	2019.06.20
2	LISN	SCHWARZBECK	NSLK8127	8127739	2018.06.19	2019.06.19
3	LISN	R&S	ENV216	101375	2018.06.20	2019.06.20
4	RF cables	Huber+Suhnar	9kHz-30MHz	B1702988-0008	2019.02.12	2020.02.12
5	Software	Frad	EZ-EMC	EMC-CON 3A1	\	\

4.2. For Radiated Emission Measurement

Item	Equipment	Manufacturer	Type No.	Serial No.	Last calibration	Calibrated until
1	Spectrum Analyzer (9kHz-26.5GHz)	Agilent	E4407B	MY45109572	2018.06.20	2019.06.20
2	Test Receiver (9kHz-7GHz)	R&S	ESR7	101154	2018.06.20	2019.06.20
3	Bilog Antenna (30MHz-3GHz)	SCHWARZBEC K	VULB9163	VULB9163-942	2018.06.23	2019.06.23
4	Horn Antenna (1GHz-18GHz)	SCHWARZBEC K	BBHA9120D	1541	2018.06.23	2019.06.22
5	Horn Antenna (18GHz-40GHz)	SCHWARZBEC K	BBHA9170	822	2018.08.06	2019.08.06
6	Amplifier (9kHz-6GHz)	SCHWARZBEC K	BBV9744	9744-0037	2018.06.20	2019.06.20
7	Amplifier (0.5GHz-18GHz)	SCHWARZBEC K	BBV9718	9718-309	2018.06.20	2019.06.20
8	Amplifier (18GHz-40GHz)	MITEQ	TTA1840-35-H G	2034381	2018.08.06	2019.08.06
9	Loop Antenna (9kHz-30MHz)	SCHWARZBEC K	FMZB1519B	014	2018.06.23	2019.06.23
10	RF cables1 (9kHz-30MHz)	Huber+Suhnar	9kHz-30MHz	B1702988-0008	2019.02.12	2020.02.12
11	RF cables2 (30MHz-1GHz)	Huber+Suhnar	30MHz-1GHz	1486150	2018.03.27	2019.03.27
12	RF cables3 (1GHz-40GHz)	Huber+Suhnar	1GHz-40GHz	1607106	2018.06.19	2019.06.19
13	Power Metter	Keysight	E4419	\	2018.04.15	2019.04.15
14	Power Sensor (AV)	Keysight	E9 300A	\	2018.04.15	2019.04.15
15	Signal Analyzer 20kHz-26.5GHz	KEYSIGHT	N9020A	MY49100060	2018.08.14	2019.08.13
16	Test Receiver 9kHz-40GHz	R&S	FSP40	100550	2018.06.13	2019.06.12
17	D.C. Power Supply	LongWei	TPR-6405D	\	\	\
18	Software	Frad	EZ-EMC	FA-03A2 RE	\	\

5. CONDUCTED EMISSION TEST

5.1. Block Diagram of Test Setup

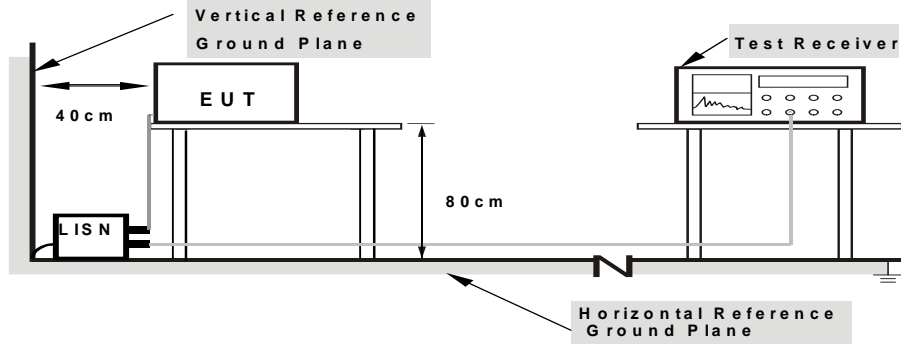

Note: 1. Support units were connected to second LISN.
 2. Both of LISNs (AMN) are 80 cm from EUT and at least 80 cm from other units and other metal planes

The setup of EUT is according with per ANSI C63.10-2013 measurement procedure. The specification used was with the FCC Part 15.207 limits.

5.2. Test Standard

FCC§15.207

5.3. Conducted Emission Limit

Frequency MHz	Limits dB(μ V)	
	Quasi-peak Level	Average Level
0.15 ~ 0.50	66 ~ 56*	56 ~ 46*
0.50 ~ 5.00	56	46
5.00 ~ 30.00	60	50

Notes: 1. *Decreasing linearly with logarithm of frequency.

5.4. EUT Configuration on Test

The following equipments are installed on conducted emission test to meet FCC Part 15.207 requirement and operating in a manner, which tends to maximize its emission characteristics in a normal application.

5.5. Operating Condition of EUT

5.5.1. Setup the EUT and simulators as shown in Section 5.1.

5.5.2. Turn on the power of all equipments.

5.5.3. Let the EUT work in test modes (EUT Working) and test it.

5.6. Test Procedure

The EUT is put on a table of non-conducting material that is 80cm high. The vertical conducting wall of shielding is located 40cm to the rear of the EUT. The power line of the EUT is connected to the AC mains through a Artificial Mains Network (A.M.N.). A EMI test receiver (R&S Test Receiver ESHS30) is used to test the emissions form both sides of AC line. The bandwidth of EMI test receiver is set at 9kHz.

The bandwidth of the test receiver (R&S Test Receiver ESHS30) is set at 10KHz.

We pretest AC 120V and AC 240V, the worst voltage was AC 120V and the data recording in the report.

5.7. Test Result

PASS

EUT:	2500 mAh Suction Wireless Power Bank	Model Name :	MSL-W186
Temperature:	26 °C	Relative Humidity:	54%
Pressure:	101kPa	Phase :	L
Test Voltage :	DC 5V, 2A form Adapter AC 120V/60Hz	Test Mode:	Normal

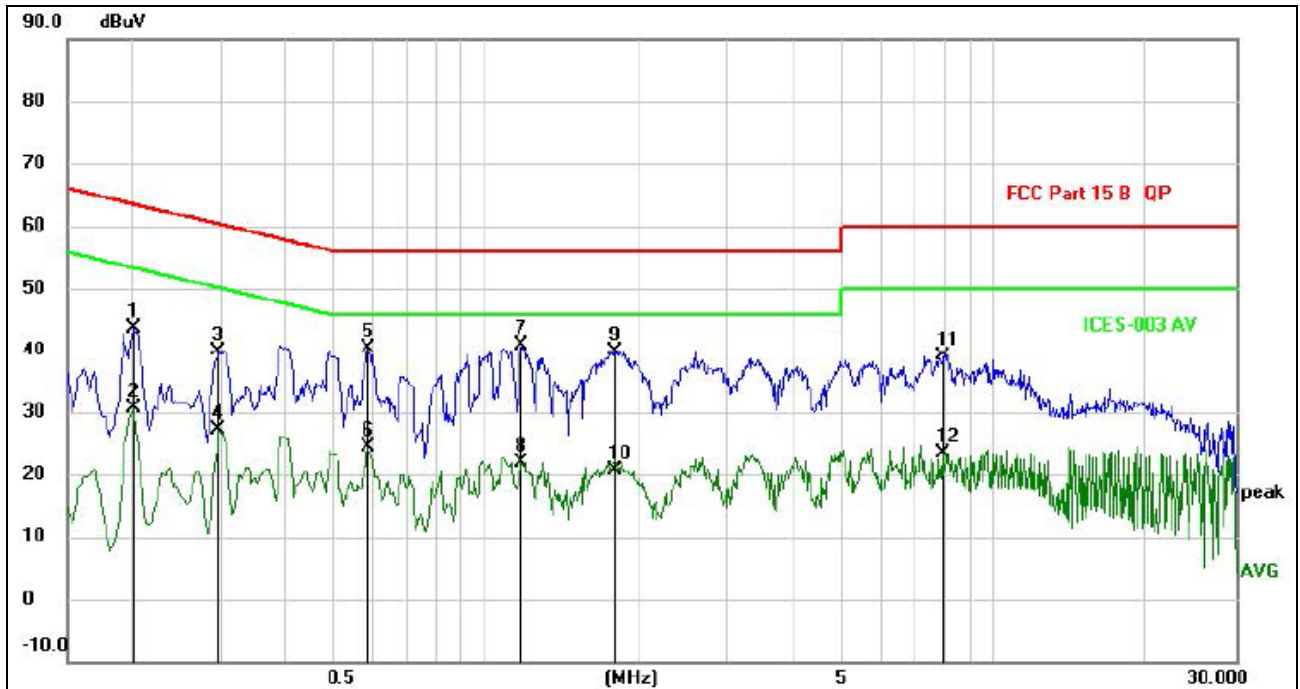
Remark:

1. All readings are Quasi-Peak and Average values.
2. Factor = Insertion Loss + Cable Loss.

No. Mk.	Freq. MHz	Reading Level dBuV	Correct Factor	Measurement dBuV	Limit dBuV	Over dB	Detector	Comment
1	0.2020	34.08	9.46	43.54	63.53	-19.99	QP	
2	0.2020	21.08	9.46	30.54	53.53	-22.99	AVG	
3	0.2980	30.22	9.58	39.80	60.30	-20.50	QP	
4	0.2980	17.48	9.58	27.06	50.30	-23.24	AVG	
5	0.5899	30.42	9.96	40.38	56.00	-15.62	QP	
6	0.5899	14.42	9.96	24.38	46.00	-21.62	AVG	
7 *	1.1780	31.35	9.57	40.92	56.00	-15.08	QP	
8	1.1780	12.25	9.57	21.82	46.00	-24.18	AVG	
9	1.7940	30.26	9.59	39.85	56.00	-16.15	QP	
10	1.7940	11.11	9.59	20.70	46.00	-25.30	AVG	
11	7.9140	29.31	9.71	39.02	60.00	-20.98	QP	
12	7.9140	13.77	9.71	23.48	50.00	-26.52	AVG	

EUT:	2500 mAh Suction Wireless Power Bank	Model Name :	MSL-W186
Temperature:	26 °C	Relative Humidity:	54%
Pressure:	101kPa	Phase :	N
Test Voltage :	DC 5V, 2A form Adapter AC 120V/60Hz	Test Mode:	Normal

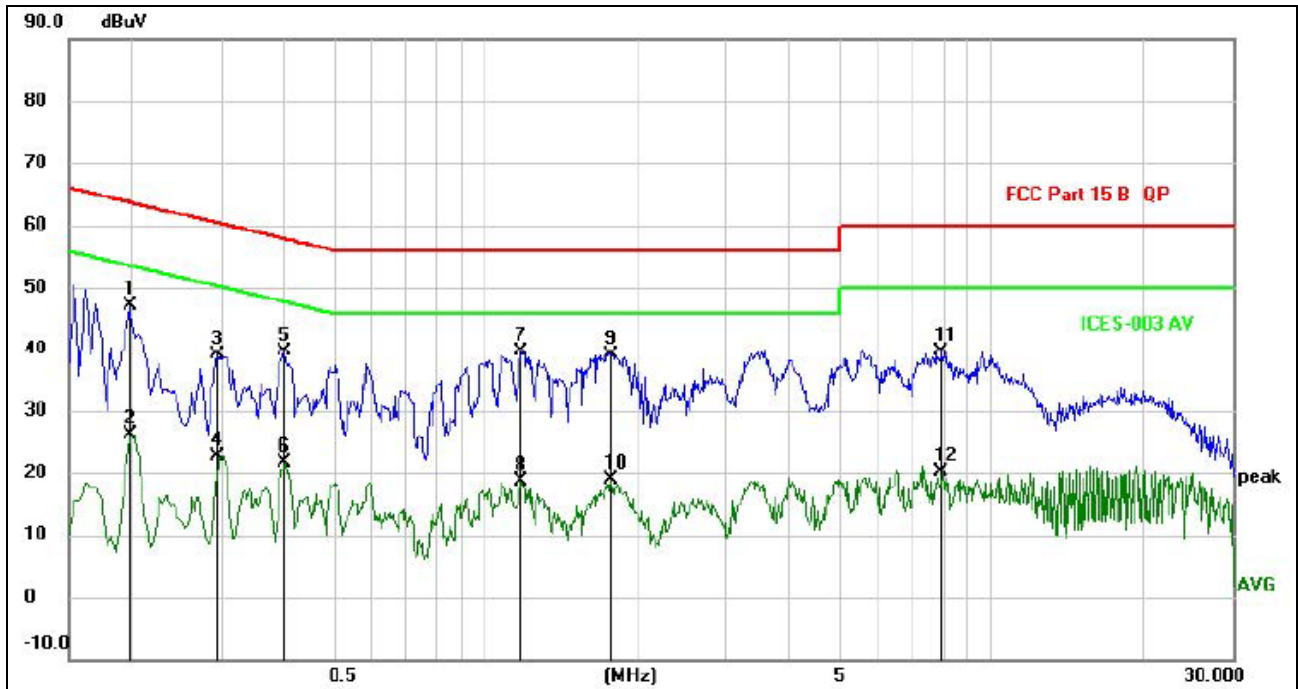
Remark:

1. All readings are Quasi-Peak and Average values.
2. Factor = Insertion Loss + Cable Loss.

No. Mk.	Freq. MHz	Reading Level dBuV	Correct Factor	Measurement dBuV	Limit dBuV	Over dB	Detector	Comment
1	0.1980	37.58	9.46	47.04	63.69	-16.65	QP	
2	0.1980	16.57	9.46	26.03	53.69	-27.66	AVG	
3	0.2940	29.54	9.57	39.11	60.41	-21.30	QP	
4	0.2940	13.05	9.57	22.62	50.41	-27.79	AVG	
5	0.3980	30.05	9.50	39.55	57.90	-18.35	QP	
6	0.3980	12.22	9.50	21.72	47.90	-26.18	AVG	
7 *	1.1780	29.98	9.57	39.55	56.00	-16.45	QP	
8	1.1780	8.97	9.57	18.54	46.00	-27.46	AVG	
9	1.7780	29.65	9.59	39.24	56.00	-16.76	QP	
10	1.7780	9.26	9.59	18.85	46.00	-27.15	AVG	
11	7.9740	29.96	9.71	39.67	60.00	-20.33	QP	
12	7.9740	10.51	9.71	20.22	50.00	-29.78	AVG	

6. RADIATED EMISSION MEASUREMENT

6.1. Block Diagram of Test Setup

6.1.1. Block Diagram of connection between the EUT and the simulators

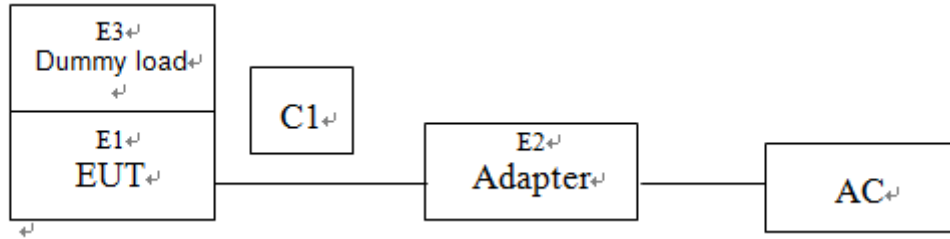

6.1.2. Anechoic Chamber Test Setup Diagram

(A) Radiated Emission Test-Up Frequency Below 30MHz

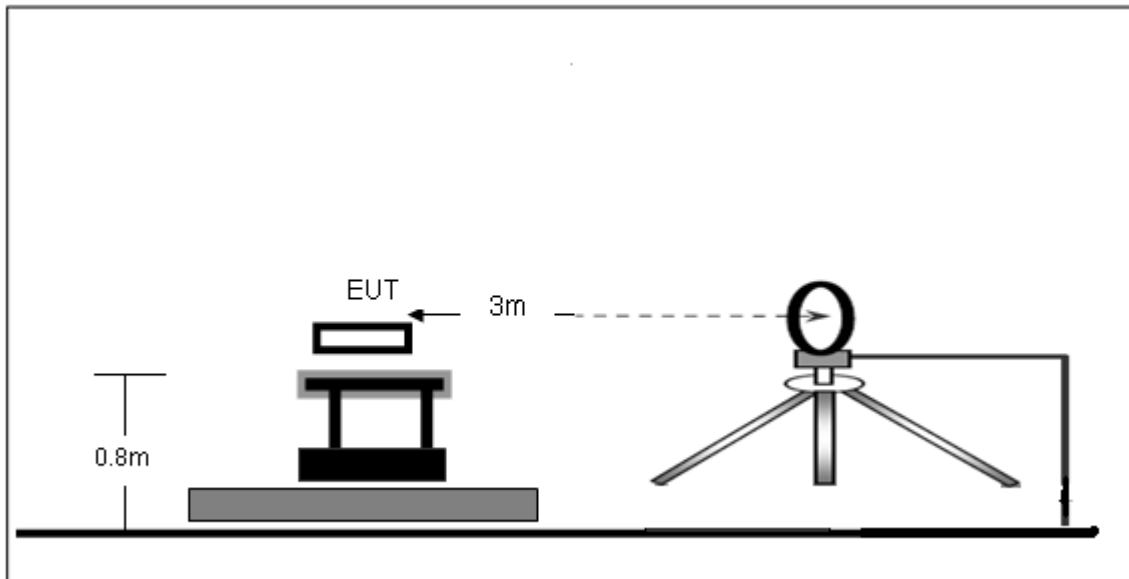

(B) Radiated Emission Test-Up Frequency 30MHz~1GHz

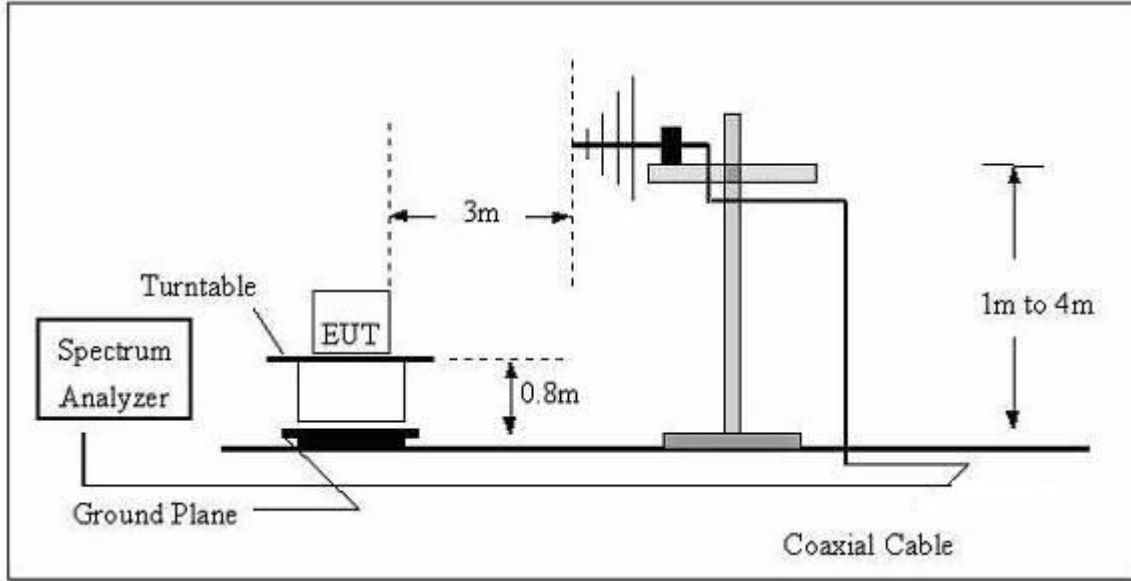

The radiated emission tests were performed in the 3 meters chamber test site, using the setup accordance with the ANSI C63.10-2013. The specification used was the FCC 15.209 and FCC 15.205 limits.

6.2. Test Standard and Limit

FCC §15.209; §15.205

Test Standard	FCC Part15 C Section 15.209 and 15.205				
	Frequency (MHz)	Field strength (microvolt/meter)	Limit (dBuV/m)	Remark	Measurement distance (m)
Test Limit	0.009MHz~0.490MHz	2400/F(kHz)	-	-	300
	0.490MHz~1.705MHz	24000/F(kHz)	-	-	30
	1.705MHz~30MHz	30	-	-	30
	30MHz~88MHz	100	40.0	Quasi-peak	3
	88MHz~216MHz	150	43.5	Quasi-peak	3
	216MHz~960MHz	200	46.0	Quasi-peak	3
	Above 1000MHz	500	54.0	Average	3
			74.0	Peak	3

6.3.EMI Test Receiver Setup

The system was investigated from 9kHz to1GHz.

During the radiated emission test, the EMI test receiver setup was set with the following configurations:

Frequency Range	RBW	Video B/W	Detector
9 kHz – 150 kHz	200 kHz	1 kHz	QP
150 kHz – 30MHz	9kHz	30kHz	QP
30 MHz – 1000 MHz	120 kHz	300 kHz	QP

Note: For the frequency bands 9-90 kHz and 110-490 kHz, the test was based on average detector.

6.4.Test Procedure

The EUT is placed on a turn table which is 0.8 meter above ground. The turn table can rotate 360 degrees to determine the position of the maximum emission level. The EUT is set 3 meters away from the receiving antenna which is mounted on a antenna tower. The antenna can move up and down between 1 to 4 meters to find out the maximum emission level. Broadband antenna (calibrated by dipole antenna) are used as a receiving antenna. Both horizontal and vertical polarization of the antenna are set on measurement.

6.5.Test Result

PASS

9kHz-30MHz

EUT:	2500 mAh Suction Wireless Power Bank	Model Name :	MSL-W186
Temperature:	26 °C	Relative Humidity:	54%
Pressure:	101kPa	Polarization :	Horizontal
Test Voltage :	DC 9V, 1.5A form Adapter AC 120V/60Hz		
Test Mode :	Normal		

Frequency	Meter Reading	Factor	Emission Level	Limits	Margin	Detector Type
(kHz)	(dBμV)	(dB)	(dBμV/m)	(dBμV/m)	(dB)	
45.3600	39.58	20.21	58.71	134.47	-75.76	PK
45.3600	34.26	20.21	54.67	114.47	-59.80	AV
80.4700	50.57	20.32	71.35	129.49	-58.14	PK
80.4700	46.35	20.32	67.22	109.49	-42.27	AV
145.5500	68.96	20.36	87.42	124.34	-36.92	PK
145.5500	65.35	20.36	84.56	104.34	-19.78	AV
880.2500	30.69	20.47	51.98	68.71	-16.73	QP
968.5800	32.18	21.22	55.53	67.88	-12.35	QP
1452.6600	24.62	22.15	47.30	64.34	-17.04	QP

Note:

Pre-scan in the all of mode, the worst case in of was recorded.

Factor = antenna factor + cable loss – pre-amplifier.

Margin = Emission Level- Limit.

30MHz-1GHz

EUT:	2500 mAh Suction Wireless Power Bank	Model Name :	MSL-W186
Temperature:	26 °C	Relative Humidity:	54%
Pressure:	101kPa	Polarization :	Horizontal
Test Voltage :	DC 5V, 2A form Adapter AC120V/60Hz		
Test Mode :	Normal		

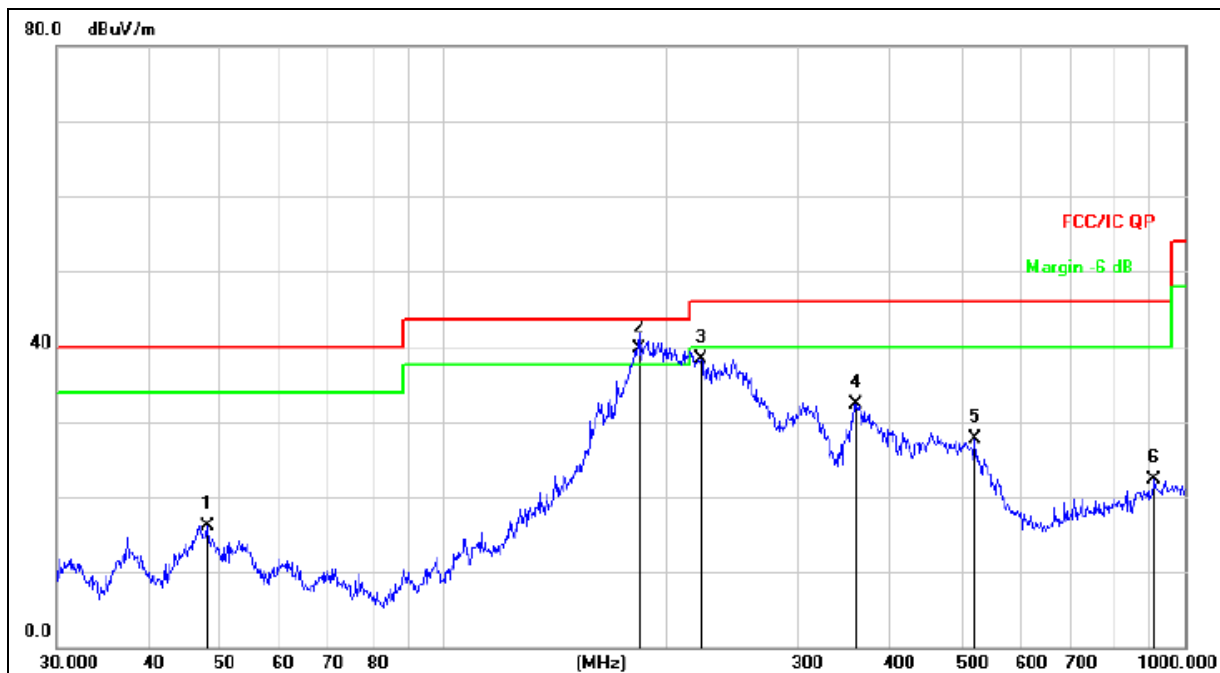

Remark:
 Factor = Antenna Factor + Cable Loss – Pre-amplifier.

No.	Mk.	Freq.	Reading Level	Correct Factor	Measurement	Limit	Over	Detector
		MHz	dBuV	dB	dBuV/m	dB/m	dB	
1		47.9940	31.09	-14.96	16.13	40.00	-23.87	QP
2	*	183.2005	57.15	-17.38	39.77	43.50	-3.73	QP
3		222.1698	54.18	-15.79	38.39	46.00	-7.61	QP
4		360.4476	44.23	-11.99	32.24	46.00	-13.76	QP
5		520.8882	36.07	-8.41	27.66	46.00	-18.34	QP
6		909.6667	23.67	-1.42	22.25	46.00	-23.75	QP

EUT:	2500 mAh Suction Wireless Power Bank	Model Name :	MSL-W186
Temperature:	26 °C	Relative Humidity:	54%
Pressure:	101kPa	Polarization :	Vertical
Test Voltage :	DC 5V, 2A form Adapter AC120V/60Hz		
Test Mode :	Normal		

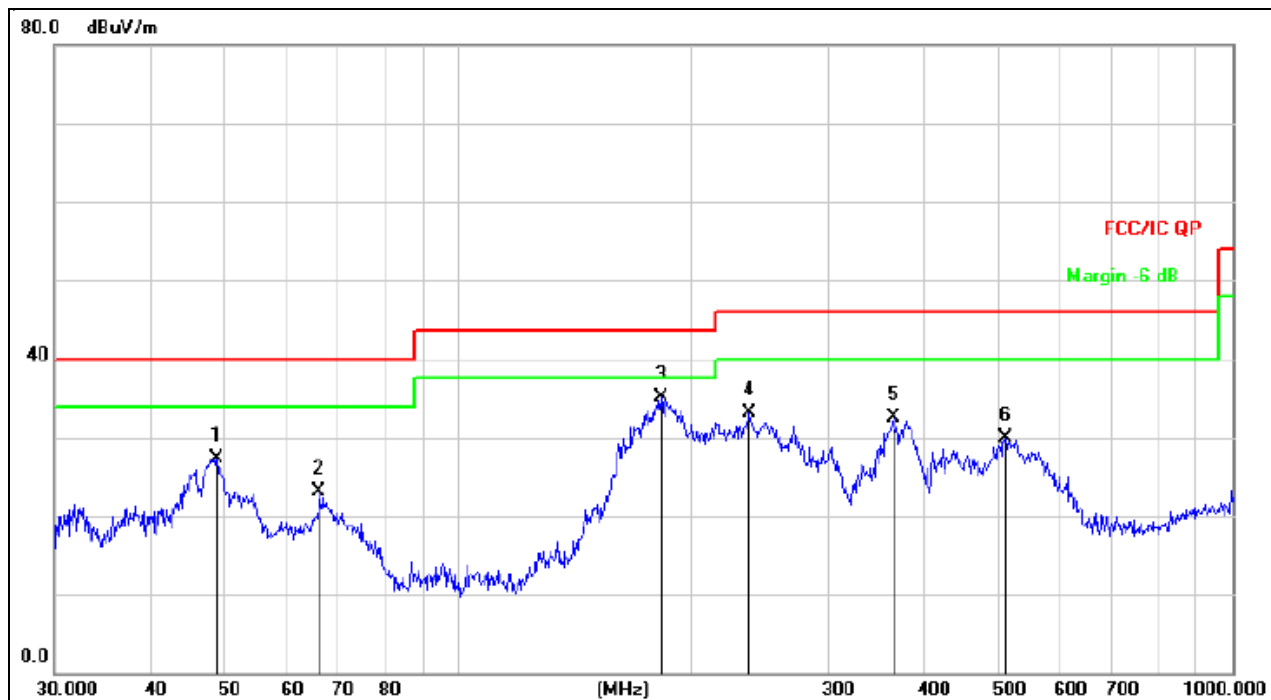

Remark:
 Factor = Antenna Factor + Cable Loss – Pre-amplifier.

No.	Mk.	Freq. MHz	Reading Level dBuV	Correct Factor dB	Measure- ment dBuV/m	Limit dB/m	Over dB	Detector
1		48.6719	42.22	-14.92	27.30	40.00	-12.70	QP
2		66.0342	40.30	-17.29	23.01	40.00	-16.99	QP
3	*	182.5592	52.45	-17.42	35.03	43.50	-8.47	QP
4		237.4760	48.61	-15.44	33.17	46.00	-12.83	QP
5		364.2595	44.43	-11.90	32.53	46.00	-13.47	QP
6		508.2582	38.66	-8.73	29.93	46.00	-16.07	QP

7. EUT TEST PHOTOS

Conducted Measurement Photos



Radiated Measurement Photos
9KHz-30MHz

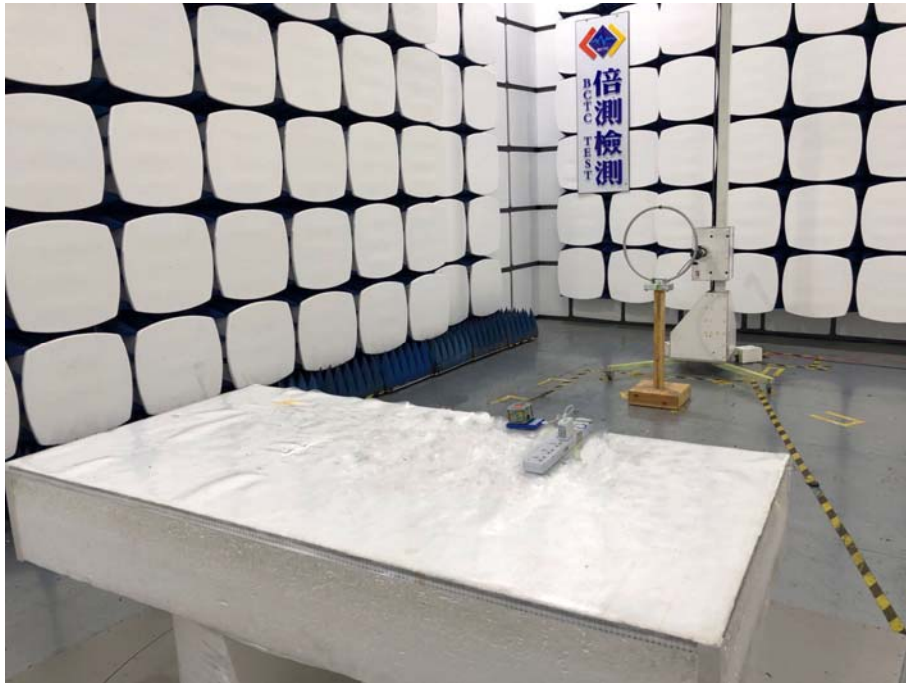

30MHz-1GHz

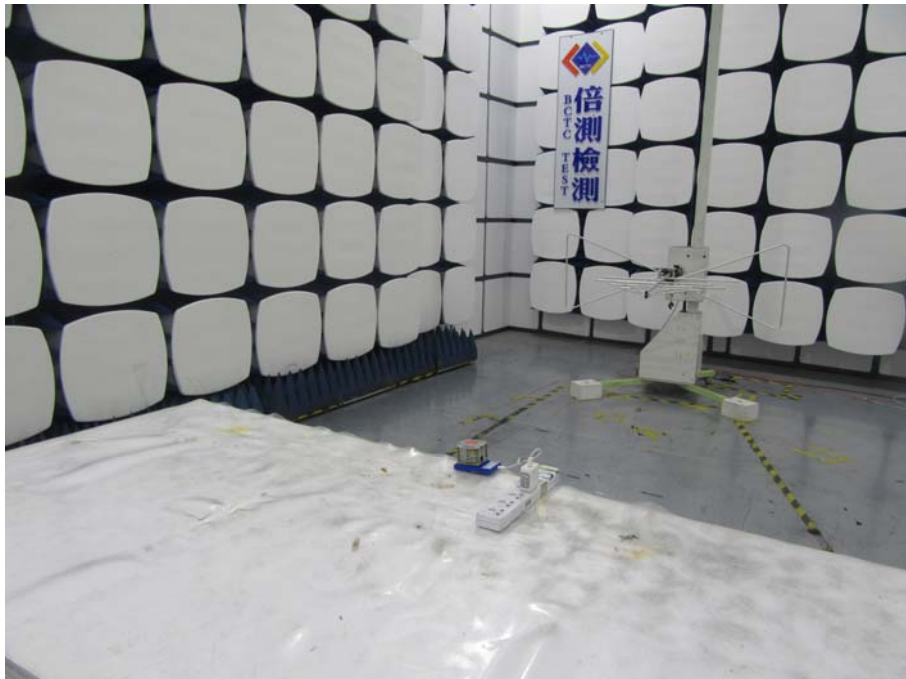

8. EUT PHOTOS

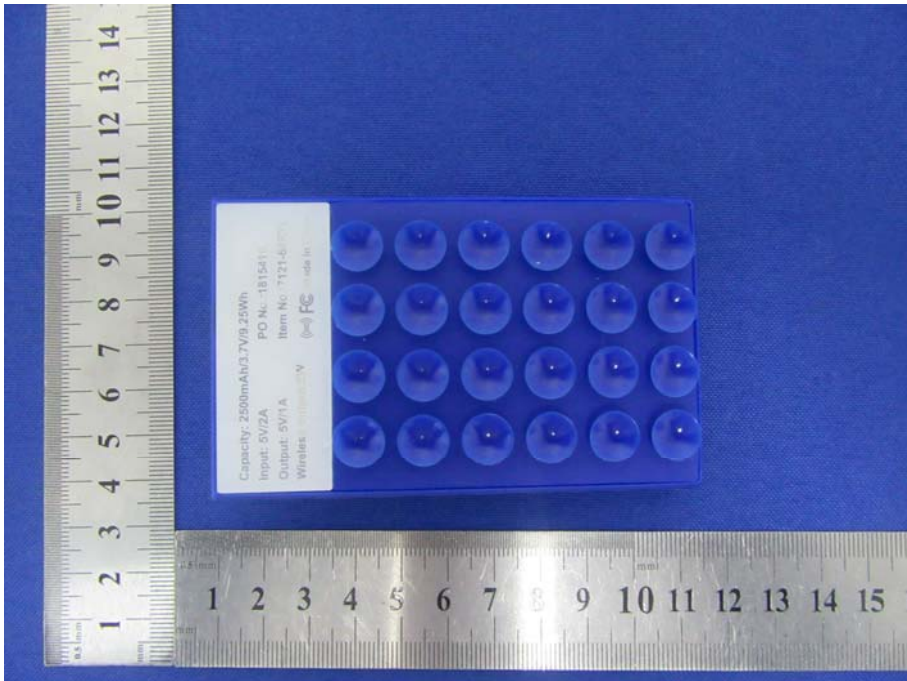
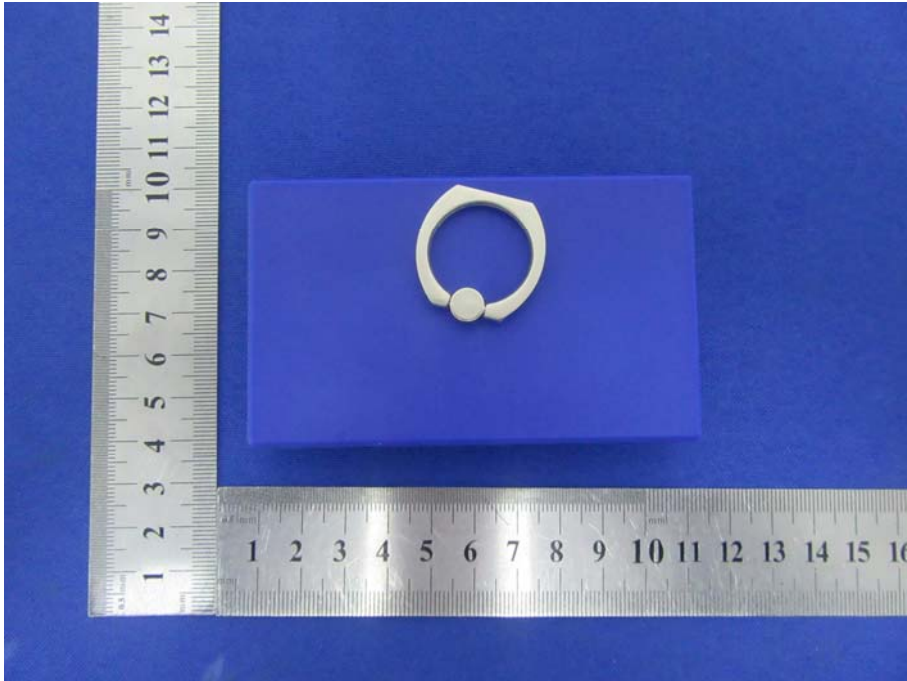

***** END OF REPORT *****