

Report on the Radio Testing  
For  
Markem-Imaje Industries Limited  
on  
SmartDate X30  
Report no. TRA-049942-45-00A  
30th August 2022

RF914 7.0



Report Number: TRA-049942-45-00A  
Issue: A

REPORT ON THE RADIO TESTING OF A  
Markem-Imaje Industries Limited  
SmartDate X30  
WITH RESPECT TO SPECIFICATION  
FCC 47CFR 15.225

TEST DATE: 2021-11-15 to 2022-06-09

Written by: Ian Broadwell

Tested by:



I. Broadwell and A. J.  
Longley  
Radio Test Engineers

Approved by:

Date: 30th August 2022

D Winstanley  
Radio Senior Test Engineer

Disclaimers:

[1] THIS DOCUMENT MAY BE REPRODUCED ONLY IN ITS ENTIRETY AND WITHOUT CHANGE  
[2] THE RESULTS CONTAINED IN THIS DOCUMENT RELATE ONLY TO THE ITEM(S) TESTED

RF914 7.0

## 1 Revision Record

<i>Issue Number</i>	<i>Issue Date</i>	<i>Revision History</i>
A	30th August 2022	Original

## 2 Summary

TEST REPORT NUMBER: TRA-049942-45-00A

WORKS ORDER NUMBER: TRA-049942-02

PURPOSE OF TEST: USA: Testing of radio frequency equipment per the relevant authorization procedure of chapter 47 of CFR (code of federal regulations) Part 2, subpart J.

TEST SPECIFICATION(S): 47CFR15.225

EQUIPMENT UNDER TEST (EUT): SmartDate X30

FCC IDENTIFIER: 2AN60-SDX30

EUT SERIAL NUMBER: E321180461

MANUFACTURER/AGENT: Markem-Imaje Industries Limited

ADDRESS: Nottingham Science & Technology Park  
University Boulevard  
Nottingham  
NG7 2QN

CLIENT CONTACT: Dawid Piech  
☎ 0115 9683 692  
✉ [dpiech@markem-imaje.com](mailto:dpiech@markem-imaje.com)

ORDER NUMBER: PO: 4502018359

TEST DATE: 2021-11-15 to 2022-06-09

TESTED BY: I. Broadwell and A. J. Longley  
Element

## 2.1 Test Summary

Test Method and Description	Requirement Clause	Applicable to this equipment	Result / Note
	47CFR15		
Radiated spurious emissions, below 30 MHz	15.225(d)	☒	Pass
Radiated spurious emissions	15.209	☒	Pass
AC power line conducted emissions	15.207	☒	Pass
Occupied bandwidth	15.215(c)	☒	Pass
Field strength of fundamental	15.225(a), (b) and (c)	☒	Pass
Frequency stability	15.225(e)	☒	Pass

### Notes:

The results contained in this report relate only to the items tested, in the condition at time of test, and were obtained in the period between the date of initial receipt of samples and the date of issue of the report.

The apparatus was set up and exercised using the configurations, modes of operation and arrangements defined in this report only. Any modifications made are identified in Section 8 of this report.

Particular operating modes, apparatus monitoring methods and performance criteria required by the standards tested to have been performed except where identified in Section 5.2 of this test report (Deviations from Test Standards).

### 3 Contents

1	Revision Record .....	3
2	Summary .....	4
2.1	Test Summary .....	5
3	Contents .....	6
4	Introduction .....	8
5	Test Specifications .....	9
5.1	Normative References .....	9
5.2	Deviations from Test Standards .....	9
6	Glossary of Terms .....	10
7	Equipment Under Test .....	11
7.1	EUT Identification .....	11
7.2	System Equipment .....	11
7.3	EUT Mode of Operation .....	11
7.4	EUT Radio Parameters .....	12
7.4.1	General .....	12
7.4.2	Antennas .....	12
7.5	EUT Description .....	12
8	Modifications .....	13
9	EUT Test Setup .....	14
9.1	Block Diagram .....	14
9.2	General Set-up Photograph .....	15
9.3	Measurement software .....	15
10	General Technical Parameters .....	16
10.1	Normal Conditions .....	16
10.2	Varying Test Conditions .....	16
11	Radiated emissions below 30 MHz .....	17
11.1	Definitions .....	17
11.2	Test Parameters .....	17
11.3	Test Limit .....	18
11.4	Test Method .....	18
11.5	Test Set-up Photograph .....	19
11.6	Test Equipment .....	20
11.7	Test Results .....	21
12	Radiated emissions .....	23
12.1	Definitions .....	23
12.2	Test Parameters .....	23
12.3	Test Limit .....	23
12.4	Test Method .....	24
12.5	Test Set-up Photograph .....	25
12.6	Test Equipment .....	26
12.7	Test Results .....	26
13	AC power-line conducted emissions .....	27
13.1	Definition .....	27
13.2	Test Parameters .....	27
13.3	Test Limit .....	27
13.4	Test Method .....	28
13.5	Test Set-up Photograph .....	28
13.6	Test Equipment .....	29
13.7	Test Results .....	29
14	Occupied Bandwidth .....	30
14.1	Definition .....	30
14.2	Test Parameters .....	30
14.3	Test Limit .....	30
14.4	Test Method .....	31
14.5	Test Equipment .....	31
14.6	Test Results .....	31
15	Transmitter output power (fundamental radiated emission) .....	33
15.1	Definition .....	33
15.2	Test Parameters .....	33
15.3	Test Limit .....	33
15.4	Test Method .....	34
15.5	Test Equipment .....	34
15.6	Test Results .....	35
16	Frequency stability .....	36
16.1	Definition .....	36

16.2	Test Parameters .....	36
16.3	Test Limit .....	36
16.4	Test Method .....	36
16.5	Test Equipment .....	37
16.6	Test Results .....	37
17	Measurement Uncertainty .....	38
18	RF Exposure .....	40

## 4 Introduction

This report TRA-049942-45-00A presents the results of the Radio testing on a Markem-Imaje Industries Limited, SmartDate X30 to specification 47CFR15 Radio Frequency Devices.

The testing was carried out for Markem-Imaje Industries Limited by Element, at the address detailed below.

<input checked="" type="checkbox"/>	Element Hull Unit E South Orbital Trading Park Hedon Road Hull HU9 1NJ UK	<input type="checkbox"/>	Element Skelmersdale Unit 1 Pendle Place Skelmersdale West Lancashire WN8 9PN UK
-------------------------------------	---------------------------------------------------------------------------------------------	--------------------------	----------------------------------------------------------------------------------------------------

This report details the configuration of the equipment, the test methods used and any relevant modifications where appropriate.

All test and measurement equipment under the control of the laboratory and requiring calibration is subject to an established programme and procedures to control and maintain measurement standards. The quality management system meets the principles of ISO 9001, and has quality control procedures for monitoring the validity of tests undertaken. Records and sufficient detail are retained to establish an audit trail of calibration records relating to its test results for a defined period. Under control of the established calibration programme, key quantities or values of the test & measurement instrumentation are within specification and comply with the relevant traceable internationally recognised and appropriate standard specifications, which are UKAS calibrated as such where these properties have a significant effect on results. Participation in inter-laboratory comparisons and proficiency testing ensures satisfactory correlation of results conform to Elements own procedures, as well as statistical techniques for analysis of test data providing the appropriate confidence in measurements.

### FCC Site Listing:

The test laboratory is accredited for the above sites under the following US-UK MRA, Designation numbers.

Element Hull	UK2007
--------------	--------

The test site requirements of ANSI C63.4-2014 are met up to 1 GHz.

The test site SVSWR requirements of CISPR 16-1-4:2010 are met over the frequency range 1 GHz to 18 GHz.



## **5 Test Specifications**

### **5.1 Normative References**

- FCC 47 CFR Ch. I – Part 15 – Radio Frequency Devices.
- ANSI C63.10-2013 – American National Standard of Procedures for Compliance Testing of Unlicensed Wireless Devices.
- ANSI C63.4-2014 – American National Standard for Methods of Measurement of Radio-Noise Emissions from Low-Voltage Electrical and Electronic Equipment in the Range of 9 kHz to 40 GHz.

### **5.2 Deviations from Test Standards**

There were no deviations from the test standard.

## 6 Glossary of Terms

<b>§</b>	denotes a section reference from the standard, not this document
<b>AC</b>	Alternating Current
<b>ANSI</b>	American National Standards Institute
<b>BW</b>	bandwidth
<b>C</b>	Celsius
<b>CFR</b>	Code of Federal Regulations
<b>CW</b>	Continuous Wave
<b>dB</b>	decibel
<b>dBm</b>	dB relative to 1 milliwatt
<b>DC</b>	Direct Current
<b>DSSS</b>	Direct Sequence Spread Spectrum
<b>EIRP</b>	Equivalent Isotropically Radiated Power
<b>ERP</b>	Effective Radiated Power
<b>EUT</b>	Equipment Under Test
<b>FCC</b>	Federal Communications Commission
<b>FHSS</b>	Frequency Hopping Spread Spectrum
<b>Hz</b>	hertz
<b>IC</b>	Industry Canada (now ISED)
<b>ISED</b>	Innovation, Science and Economic Development Canada
<b>ITU</b>	International Telecommunication Union
<b>LBT</b>	Listen Before Talk
<b>m</b>	metre
<b>max</b>	maximum
<b>MIMO</b>	Multiple Input and Multiple Output
<b>min</b>	minimum
<b>MRA</b>	Mutual Recognition Agreement
<b>N/A</b>	Not Applicable
<b>PCB</b>	Printed Circuit Board
<b>PDF</b>	Portable Document Format
<b>Pt-mpt</b>	Point-to-multipoint
<b>Pt-pt</b>	Point-to-point
<b>RF</b>	Radio Frequency
<b>RH</b>	Relative Humidity
<b>RMS</b>	Root Mean Square
<b>Rx</b>	receiver
<b>s</b>	second
<b>SVSWR</b>	Site Voltage Standing Wave Ratio
<b>Tx</b>	transmitter
<b>UKAS</b>	United Kingdom Accreditation Service
<b>V</b>	volt
<b>W</b>	watt
<b>Ω</b>	ohm

## 7 Equipment Under Test

### 7.1 EUT Identification

- Name: SmartDate X30
- Serial Number: E321180461
- Model Number: SmartDate X30
- Software Revision: production
- Build Level / Revision Number: production

### 7.2 System Equipment

Equipment listed below forms part of the overall test setup and is required for equipment functionality and/or monitoring during testing. The compliance levels achieved in this report relate only to the EUT and not items given in the following list.

*Not Applicable – No support/monitoring equipment required.*

### 7.3 EUT Mode of Operation

The X30 put into transmit mode from the hand held console by selecting menus:

(Home screen) Menu -> Engineering -> Diagnostics -> Values -> ACM

Normally this is sufficient to see the fundamental at 13.56 MHz on the spectrum analyzer. The RFID tag is located in the ink cartridge and occasionally may need to be re-seated to get the X30 to acknowledge its presence. This is achieved by opening and the dial under the handle (90 degree turn to unlock and then re-close).

Photo of hand held console showing signal strength

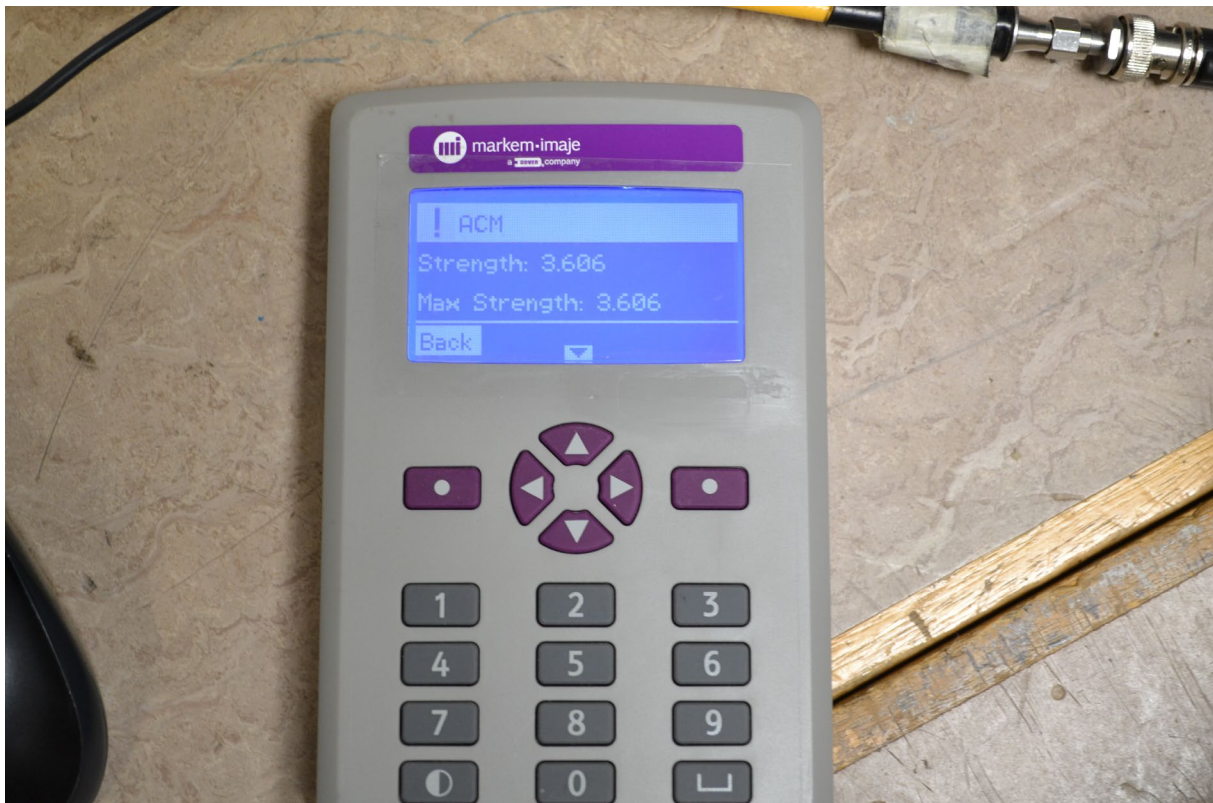

## 7.4 EUT Radio Parameters

### 7.4.1 General

<b>Frequency of operation:</b>	13.56 MHz
<b>Occupied channel bandwidth(s):</b>	1.8 MHz
<b>Declared output power(s):</b>	<200 mW
<b>Nominal Supply Voltage:</b>	100-230 V ac
<b>Duty cycle:</b>	18 %

Plot of duty cycle for wanted signal at 13.56 MHz.

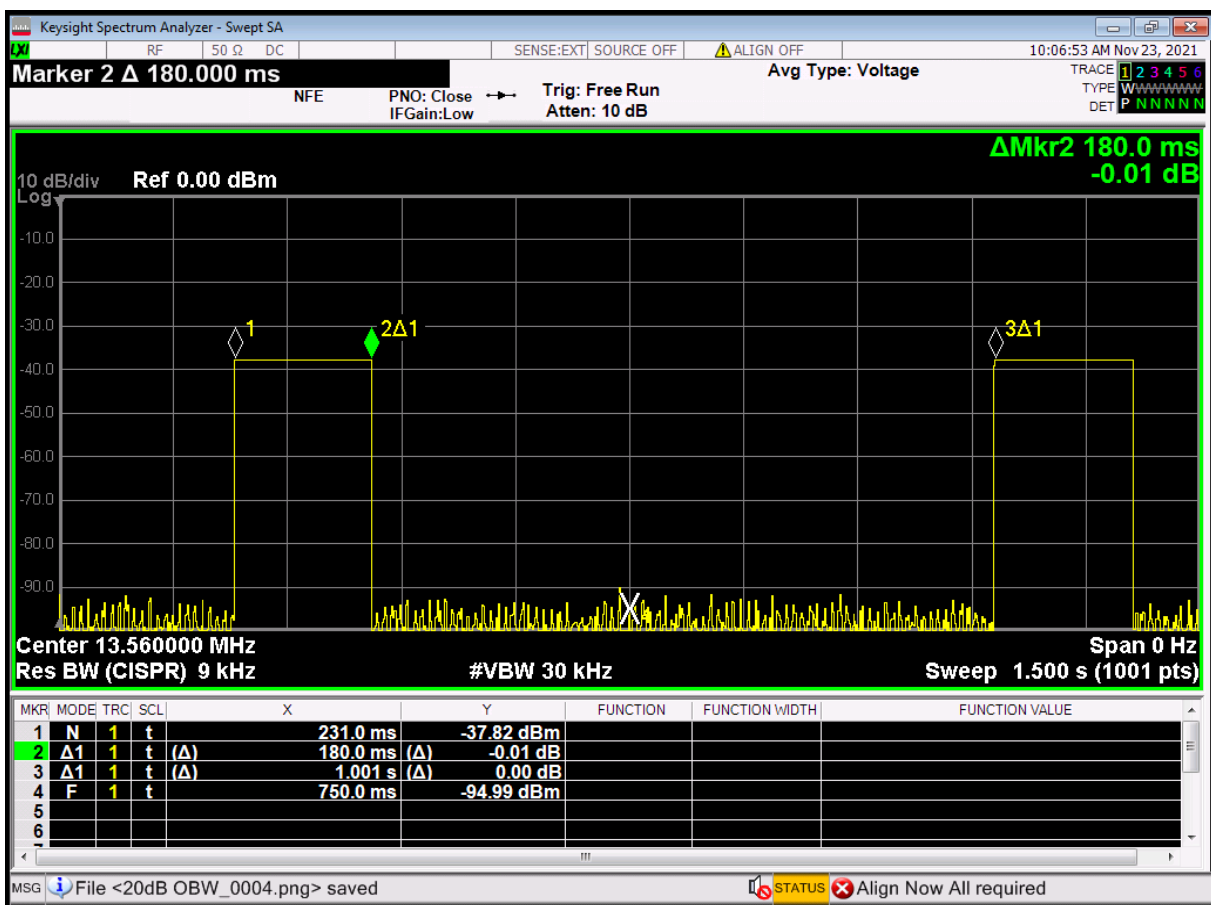

### 7.4.2 Antennas

<b>Type:</b>	The antenna is flat flexible pcb 37 x 37mm with 5 turns
<b>Frequency range:</b>	13.56 MHz

## 7.5 EUT Description

The EUT is an OEM label printer

## **8 Modifications**

No modifications were performed during this assessment.

## 9 EUT Test Setup

### 9.1 Block Diagram

The following diagram shows basic EUT interconnections with cable type and cable lengths identified:

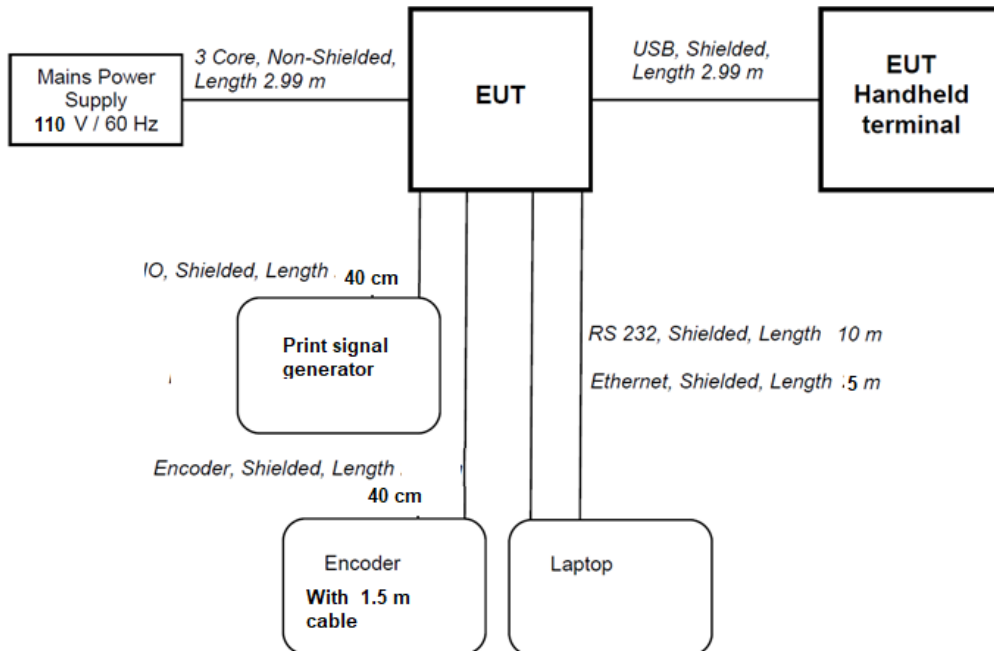

Note: For radiated testing the laptop was outside the chamber.

## 9.2 General Set-up Photograph

The following photograph shows basic EUT set-up:

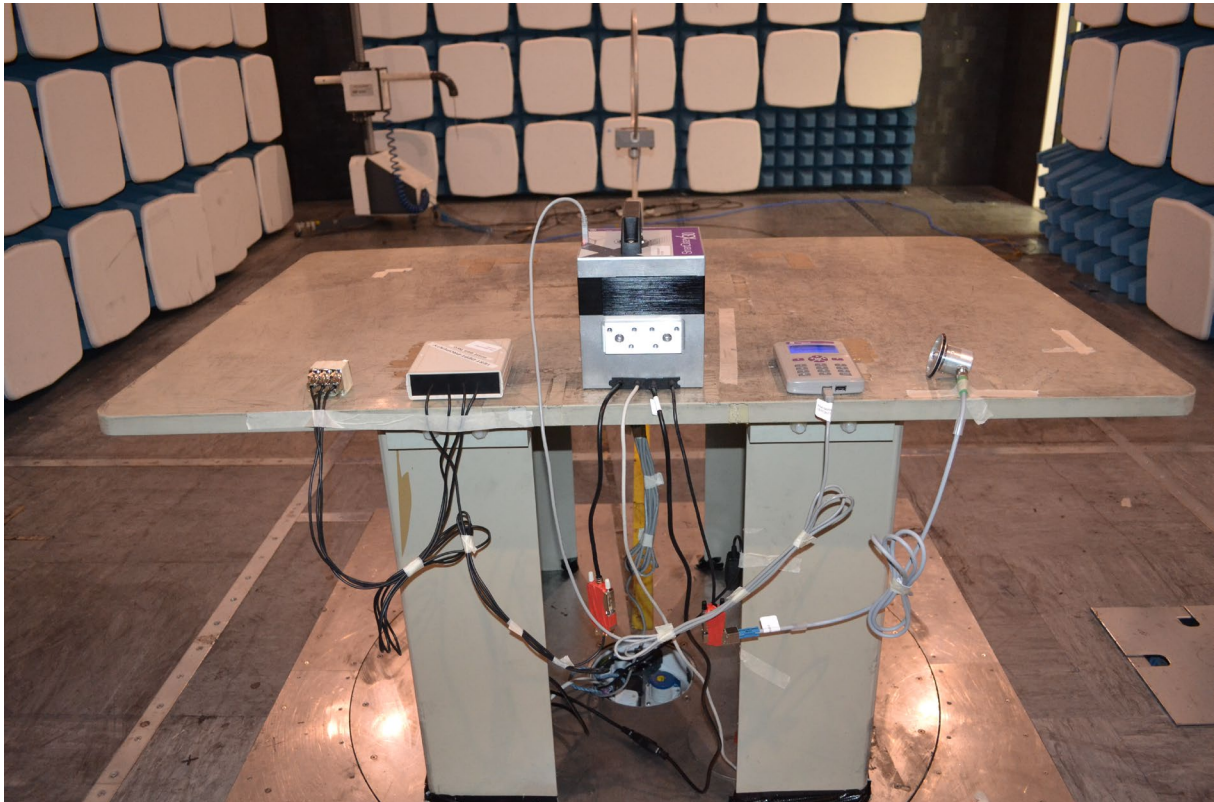

## 9.3 Measurement software

Where applicable, the following software was used to perform measurements contained within this report.

Element Emissions R5 (See Note)  
Element Transmitter Bench Test (See Note)  
ETS Lindgren EMPower V1.0.4.2

Note:

The version of the Element software used is recorded in the results sheets contained within this report.

## 10 General Technical Parameters

### 10.1 Normal Conditions

The X30 was tested under the normal environmental conditions of the test laboratory, except where otherwise stated. The normal power source applied 120 V ac, 60 Hz, from the mains.

### 10.2 Varying Test Conditions

Variation of temperature is required to ensure stability of the declared fundamental frequency. During frequency error testing the following variations were made:

	<b>Category</b>	<b>Variation</b>
☒	Standard	-20 to +50 C in 10 degree steps

Variation of supply voltage is required to ensure stability of the declared output power and frequency. During carrier power and frequency error testing the following variations were made:

	<b>Category</b>	<b>Nominal</b>	<b>Variation</b>
☒	Mains	110 V ac +/-2 %	85 % and 115 %



## 11 Radiated emissions below 30 MHz

### 11.1 Definitions

#### *Out-of-band emissions*

Emissions on a frequency or frequencies immediately outside the necessary bandwidth which result from the modulation process, but exclude spurious emissions.

#### *Spurious emissions*

Emissions on a frequency or frequencies which are outside the necessary bandwidth and the level of which may be reduced without affecting the corresponding transmission of information. Spurious emissions include harmonic emissions, parasitic emissions, intermodulation products and frequency conversion products, but exclude out-of-band emissions.

#### *Restricted bands*

A frequency band in which intentional radiators are permitted to radiate only spurious emissions but not fundamental signals.

### 11.2 Test Parameters

Test Location:	Element Hull
Test Chamber:	Wireless Lab 3
Test Standard and Clause:	ANSI C63.10-2013, Clause 6.4
Frequencies Measured:	13.56 MHz
Deviations From Standard:	None
Measurement Distance and Site	3 m Semi Anechoic Chamber and 10 m OATS without ground plane.
EUT Height:	1 m
Measurement Antenna and Height:	60 cm shielded loop; 1 m
Measurement BW:	9 kHz to 150 kHz: 200 Hz; 150 kHz to 30 MHz: 9 kHz
Measurement Detector:	9 kHz to 90 kHz and 110 kHz to 490 kHz: Average, RMS Other frequencies below 30 MHz: Quasi-peak.

### Environmental Conditions (Normal Environment)

Temperature: 24 °C	+15 °C to +35 °C (as declared)
Humidity: 42 % RH	20 % RH to 75 % RH (as declared)
Supply: 120 V ac	(as declared)

### 11.3 Test Limit

Emissions from license-exempt transmitters shall comply with the field strength limits shown in the table below. Additionally, the level of any transmitter emission shall not exceed the level of the transmitter's fundamental emission.

#### General Field Strength Limits for License-Exempt Transmitters at Frequencies Below 30 MHz

<i>Frequency, f (kHz)</i>	<i>Field Strength</i>	<i>Measurement Distance (m)</i>
9 to 490	2,400 / 377.f (μA/m) 2,400 / f (μV/m)	300
490 to 1,750	24,000 / 377.f (μA/m) 24,000 / f (μV/m)	30
1,750 to 30,000	30 (μV/m)	30

n.b. Devices operated pursuant to §15.225 are exempt from complying with the restricted band requirements for the 13.36–13.41 MHz band only.

### 11.4 Test Method

With the EUT setup as per section 9 of this report and connected as per Figure i, the EUT fundamental frequency was maximised by rotating the EUT through 360°, in three orthogonal planes, and adjusting the measurement antenna azimuth.

Radiated electromagnetic emissions from the EUT are checked first by preview scans. Preview scans for all spectrum and modulation characteristics are checked, using a peak detector and where applicable worst-case determined for function, operation, orientation, etc. for both vertical and horizontal polarisations. Pre-scan plots are shown with a peak detector and 9 kHz RBW.

If the EUT connects to auxiliary equipment and is table or floor standing, the configurations prescribed in ANSI C63.10 are followed. Alternatively, a layout closest to normal use (as declared by the provider) is employed, (see EUT setup photographs for more detail).

Emissions between 9 kHz and 30 MHz are measured using a calibrated 60cm active loop antenna. Pre-amplifiers and filters are used where required. Care is taken to ensure that test receiver resolution bandwidth, video bandwidth and detector type(s) meet the regulatory requirements.

Power values measured on the test receiver / analyzer are converted to field strength, FS, in μV/m at the regulatory distance, using:

$$FS = 10^{(PR - CF) / 20}$$

Where,

PR is the power recorded on the receiver / spectrum analyzer in dBμV and includes any cable loss, antenna factor and pre-amplifier gain;  
CF is the distance extrapolation factor in dB (where measurement distance different to limit distance);

Per FCC 47CFR15.31(f)(2) an extrapolation factor of 40 dB per decade was used for measurements at distances closer than specified.

This field strength value is then compared with the regulatory limit.

**Figure i Test Setup**

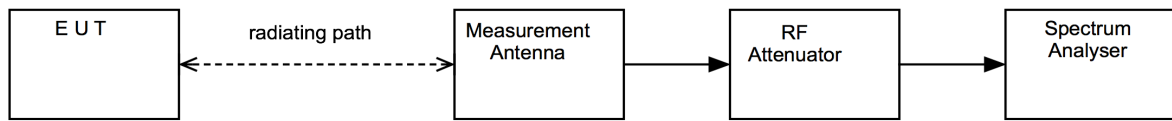

**11.5 Test Set-up Photograph**

Photo of set up inside radio chamber at 3 m separation distance.

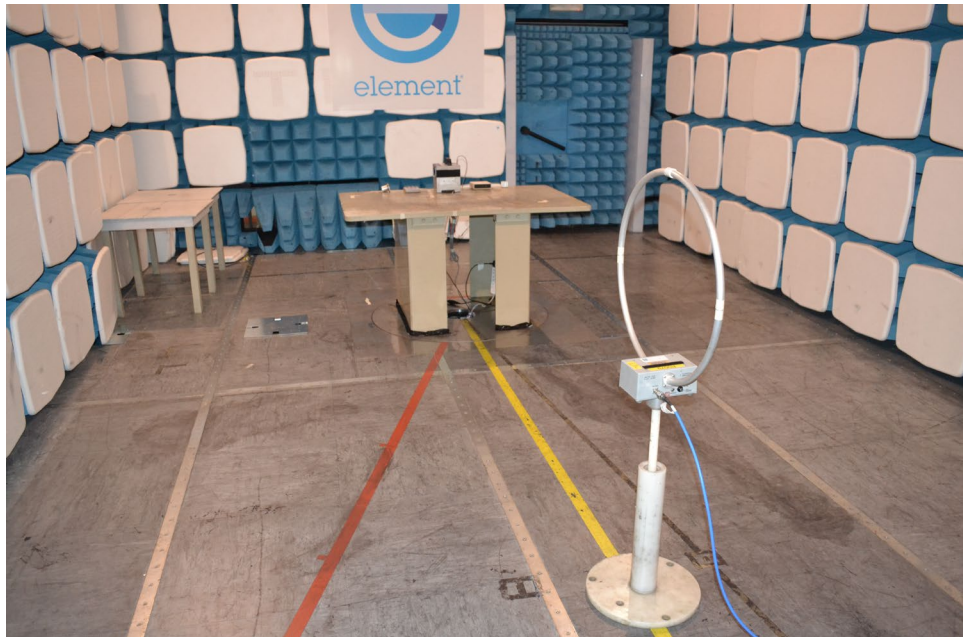

Photo of spurious set up at a measurement distance 10 m made in the car park. The wanted signal was in the noise and could only be reliably measured at 3 m.



**11.6 Test Equipment**

Equipment Type	Manufacturer	Equipment Description	Element No	Due For Calibration
ATS	Rainford	Ferrite Lined Chamber	REF886	2022-07-29
N9030A	Agilent	Spectrum Analyser	REF2167	2022-08-25
6502	EMCO	Active Loop Antenna	R0079	2023-06-16
Emissions R5	Element	Radiated Test Software	REF9000	Cal not required
34405A	Agilent	Multimeter	REF887	2022-10-12
VVC	Zenith	Variable Voltage Control	REF1270	Cal with REF887

### 11.7 Test Results

Frequency: 13.56 MHz						
Emission Frequency (MHz)	Receiver Level (dB $\mu$ V/m)	Measurement Distance (m)	Limit Distance (m)	Extrapolation Factor (dB)	Field Strength ( $\mu$ V/m)	Result
No emissions were detected within 10 dB of the limit						

9 kHz to 490 kHz horizontally polarized

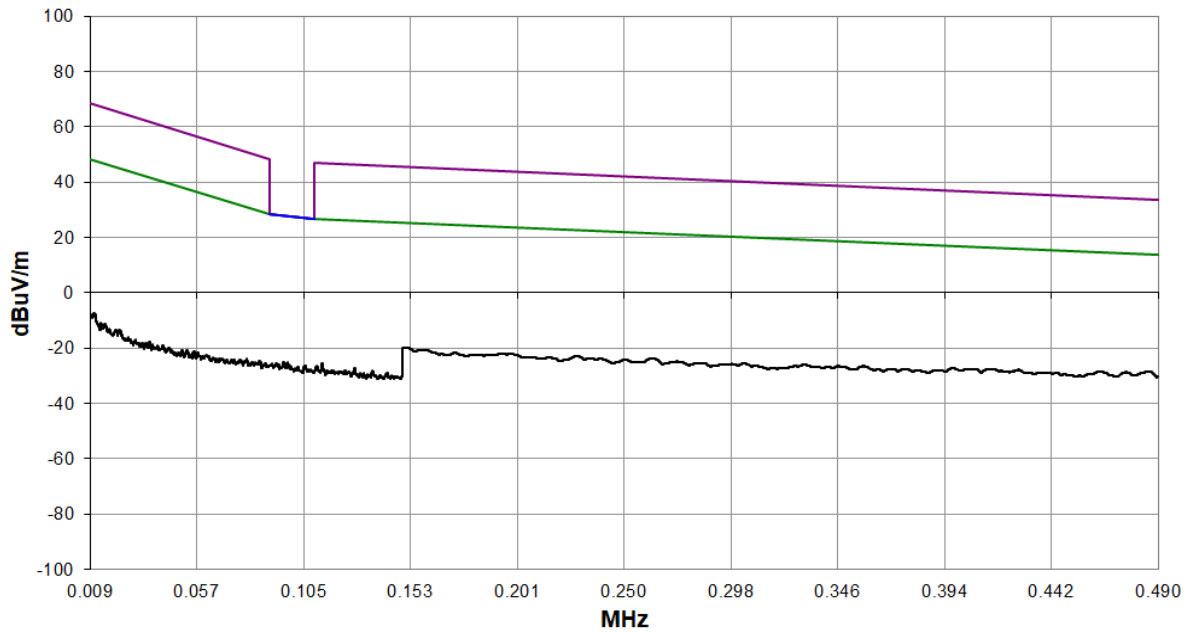

490 kHz to 30 MHz horizontally polarized

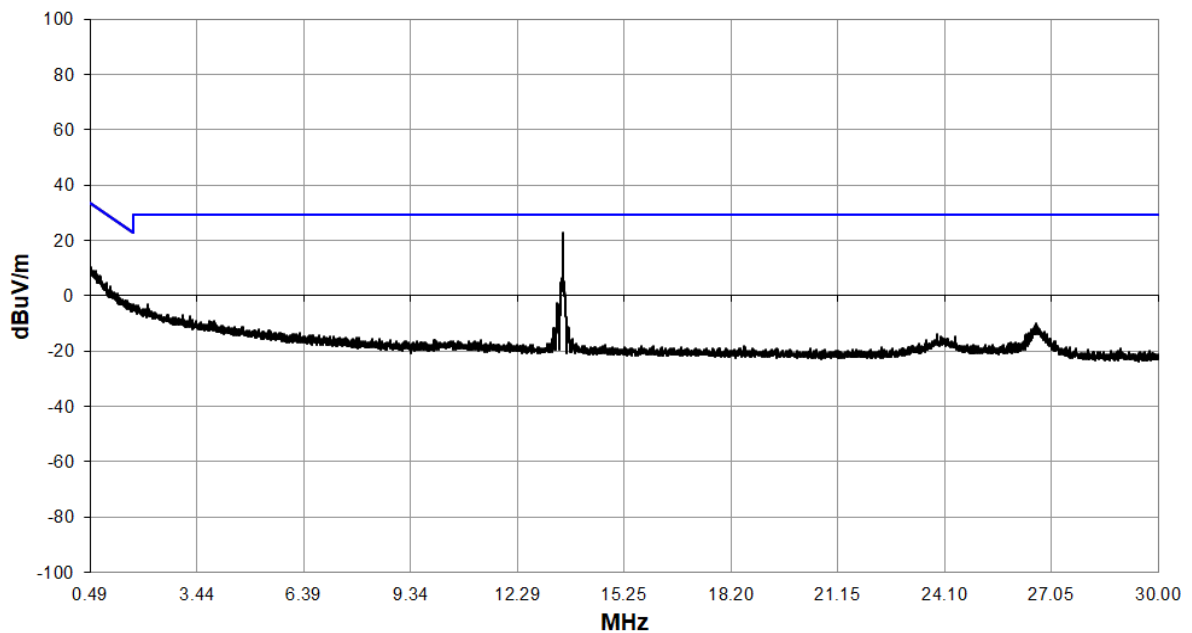

Frequency: 13.56 MHz						
Emission Frequency (MHz)	Receiver Level (dB $\mu$ V/m)	Measurement Distance (m)	Limit Distance (m)	Extrapolation Factor (dB)	Field Strength ( $\mu$ V/m)	Result
No emissions were detected within 10 dB of the limit						

9 kHz to 490 kHz vertically polarized

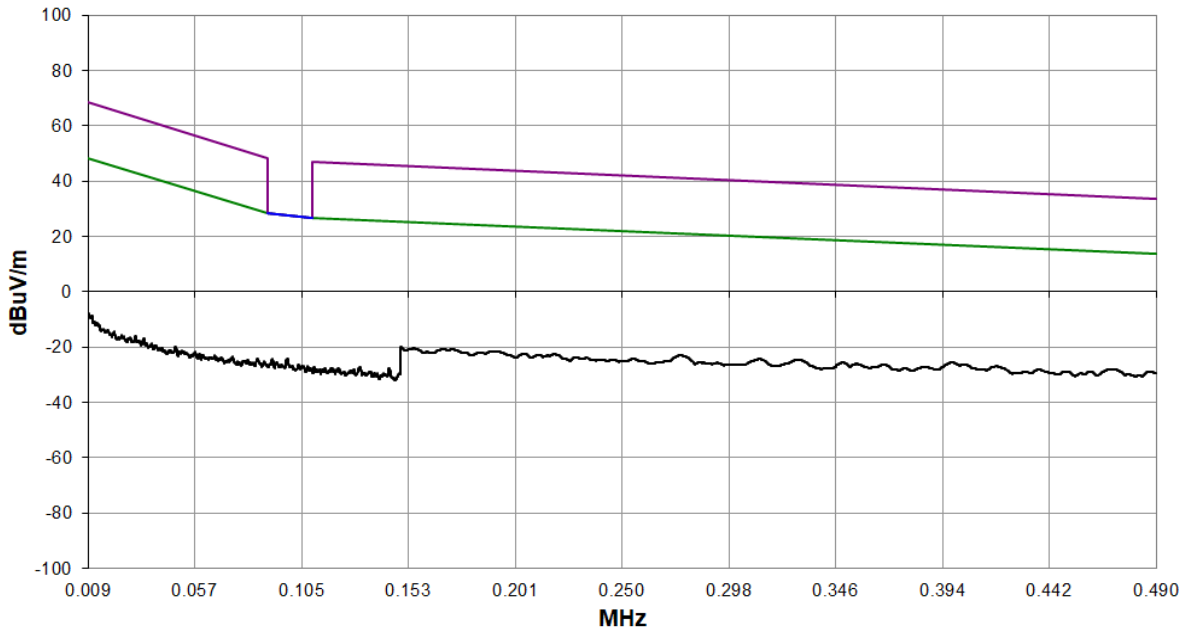

490 kHz to 30 MHz vertically polarized

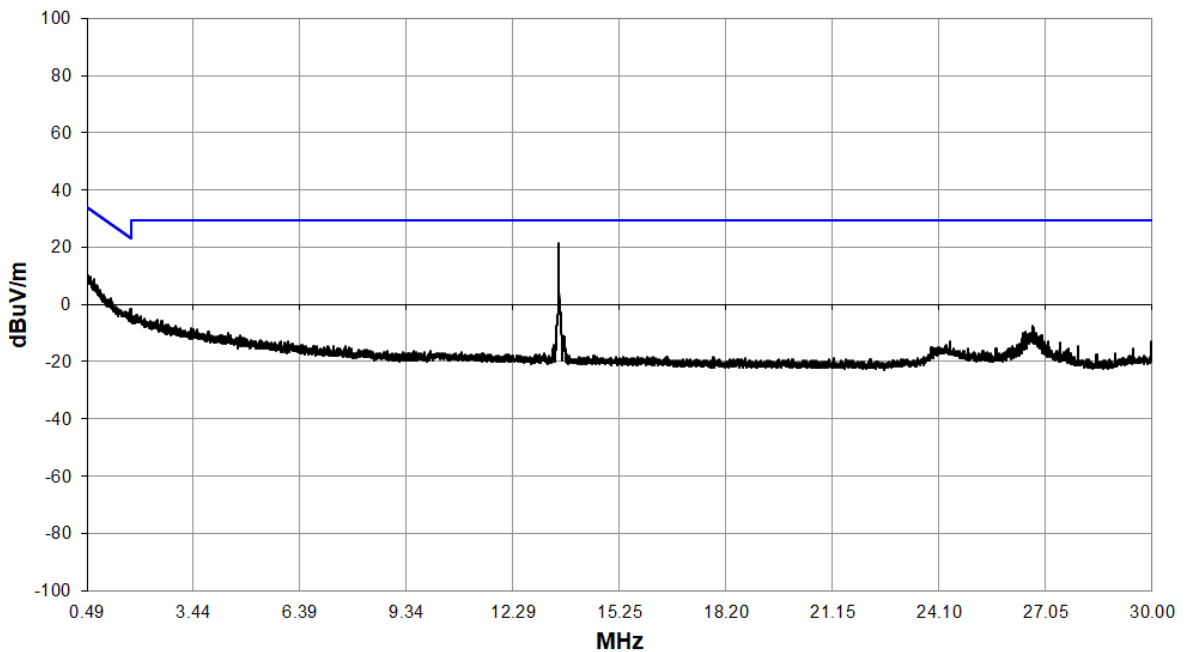

## 12 Radiated emissions

### 12.1 Definitions

#### *Out-of-band emissions*

Emissions on a frequency or frequencies immediately outside the necessary bandwidth which result from the modulation process, but exclude spurious emissions.

#### *Spurious emissions*

Emissions on a frequency or frequencies which are outside the necessary bandwidth and the level of which may be reduced without affecting the corresponding transmission of information. Spurious emissions include harmonic emissions, parasitic emissions, intermodulation products and frequency conversion products, but exclude out-of-band emissions.

#### *Restricted bands*

A frequency band in which intentional radiators are permitted to radiate only spurious emissions but not fundamental signals.

### 12.2 Test Parameters

Test Location:	Element Hull
Test Chamber:	Wireless Lab 3
Test Standard and Clause:	ANSI C63.10-2013, Clause 6.5
Frequencies Measured:	13.56 MHz
Deviations From Standard:	None
Measurement BW:	30 MHz to 1000 MHz: 120 kHz
Measurement Detector:	Quasi-peak

#### Environmental Conditions (Normal Environment)

Temperature: 24 °C	+15 °C to +35 °C (as declared)
Humidity: 42 % RH	20 % RH to 75 % RH (as declared)
Supply: 120 V ac	(as declared)

### 12.3 Test Limit

Emissions from license-exempt transmitters shall comply with the field strength limits shown in the table below. Additionally, the level of any transmitter emission shall not exceed the level of the transmitter's fundamental emission.

#### General Field Strength Limits for License-Exempt Transmitters at Frequencies above 30 MHz

<b>Frequency (MHz)</b>	<b>Field Strength (<math>\mu\text{V}/\text{m}</math> at 3 m)</b>
30 to 88	100
88 to 216	150
216 to 960	200
Above 960	500

## 12.4 Test Method

With the EUT setup as per section 9 of this report and connected as per Figure ii, the emissions from the EUT were measured on a spectrum analyzer / EMI receiver.

Radiated electromagnetic emissions from the EUT are checked first by preview scans. Preview scans for all spectrum and modulation characteristics are checked, using a peak detector and where applicable worst-case determined for function, operation, orientation, etc. for both vertical and horizontal polarisations. Pre-scan plots are shown with a peak detector and 100 kHz RBW.

If the EUT connects to auxiliary equipment and is table or floor standing, the configurations prescribed in ANSI C63.10 are followed. Alternatively, a layout closest to normal use (as declared by the provider) is employed, (see EUT setup photographs for more detail).

Emissions between 30 MHz and 1 GHz are measured using calibrated broadband antennas. Emissions above 1 GHz are characterized using standard gain horn antennas. Pre-amplifiers and filters are used where required. Care is taken to ensure that test receiver resolution bandwidth, video bandwidth and detector type(s) meet the regulatory requirements.

For both horizontal and vertical polarizations, the EUT is then rotated through 360 degrees in azimuth until the highest emission is detected. At the previously determined azimuth the test antenna is raised and lowered from 1 to 4 m in height until a maximum emission level is detected, this maximum value is recorded.

Power values measured on the test receiver / analyzer are converted to field strength, FS, in dB $\mu$ V/m at the regulatory distance, using:

$$FS = PR + CL + AF - PA + DC - CF$$

Where,

PR is the power recorded on the receiver / spectrum analyzer in dB $\mu$ V;

CL is the cable loss in dB;

AF is the test antenna factor in dB/m;

PA is the pre-amplifier gain in dB (where used);

DC is the duty correction factor in dB (where used, e.g. harmonics of pulsed fundamental);

CF is the distance factor in dB (where measurement distance is different to limit distance);

This field strength value is then compared with the regulatory limit.

**Figure ii Test Setup**

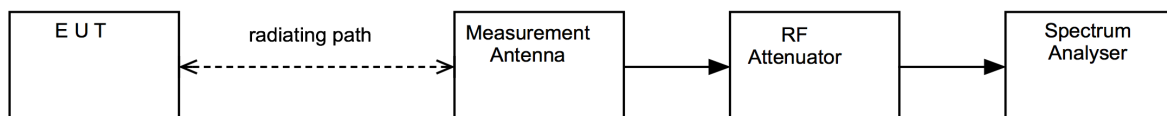



### 12.5 Test Set-up Photograph

The 13.56 MHz NFC card reader is situated in the printer part of the EUT (centre).

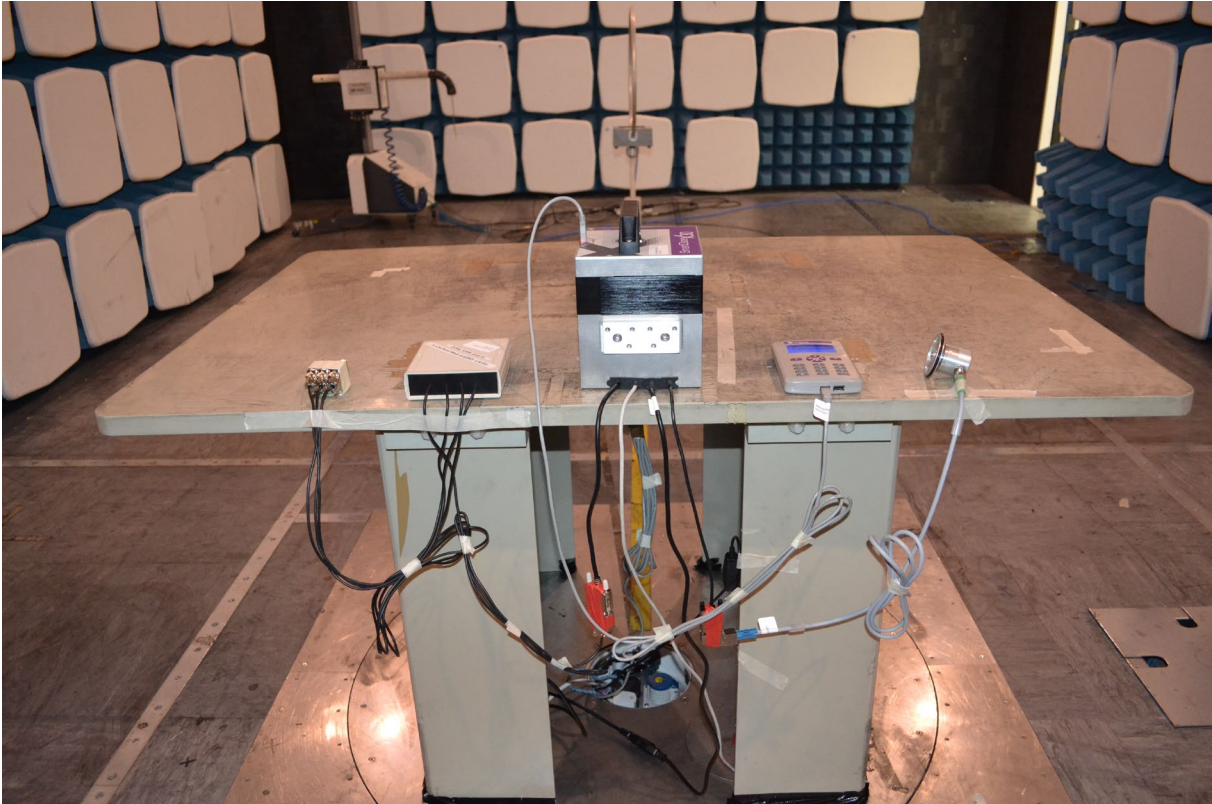

Radiated setup 30 MHz to 1 GHz range.

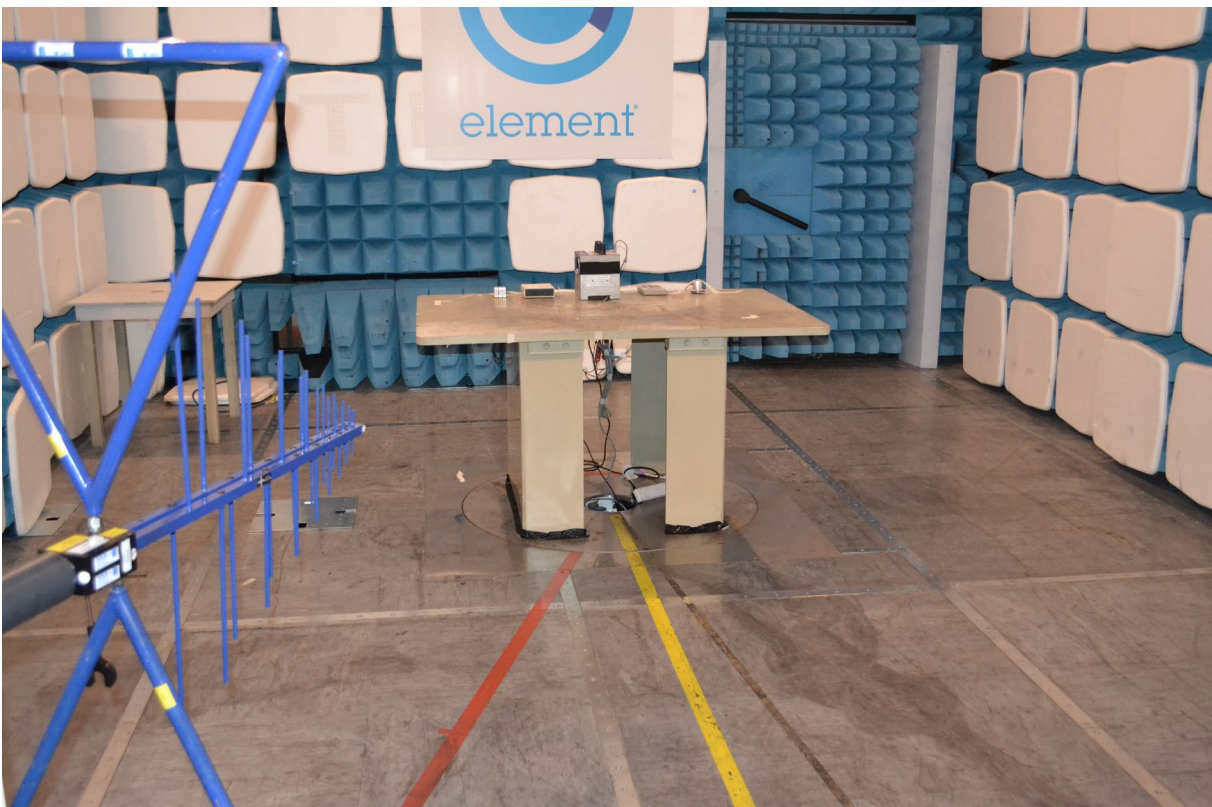

### 12.6 Test Equipment

Equipment Type	Manufacturer	Equipment Description	Element No	Due For Calibration
ATS	Rainford	Ferrite Lined Chamber	REF886	2022-07-29
N9030A	Agilent	Spectrum Analyser	REF2167	2022-08-25
310	Sonoma	Pre-Amp (9 kHz - 1 GHz)	REF927	2022-07-15
6502	EMCO	Active Loop Antenna	R0079	2023-06-16
Emissions R5	Element	Radiated Test Software	REF9000	Cal not required
34405A	Agilent	Multimeter	REF887	2022-10-12
VVC	Zenith	Variable Voltage Control	REF1270	Cal with REF887

### 12.7 Test Results

Plot of 30 MHz to 1 GHz

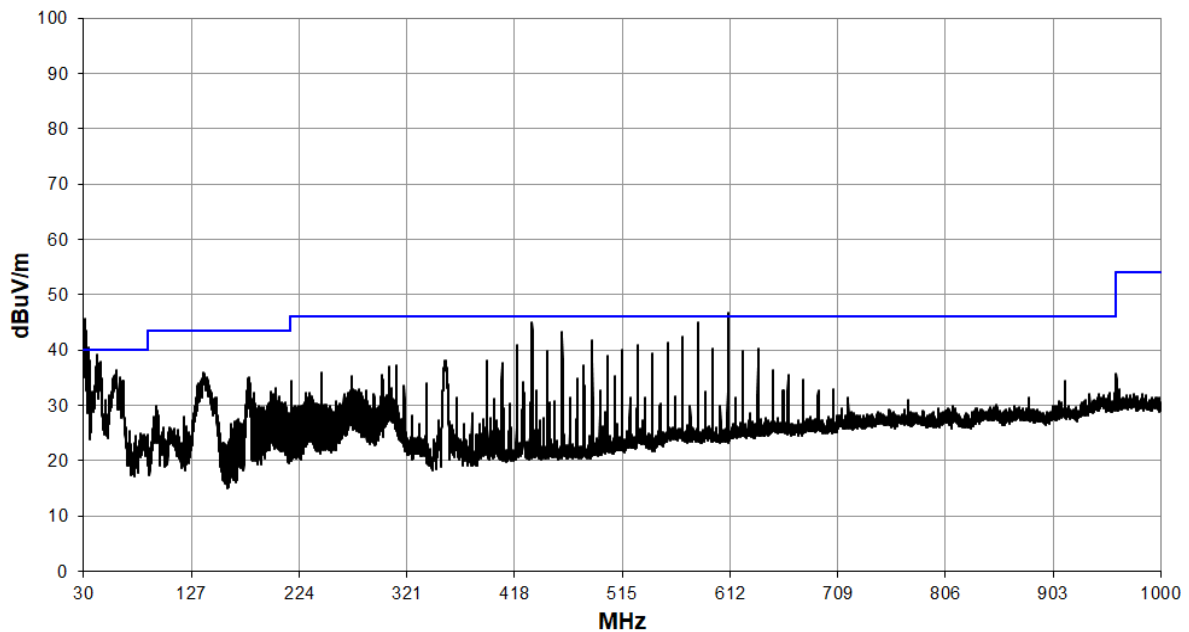

List of maximized spurious emissions within 10 dB of FCC limit.

RFID device fundamental frequency: 13.56 MHz								
Detector	Freq. (MHz)	Meas'd Emission (dBµV)	Factor (dB/m)	Duty Cycle Corr'n (dB)	Distance Extrap'n Factor (dB)	Field Strength (dBµV/m)	Field Strength (µV/m)	Limit (µV/m)
QP	31.5	46.3	-7.0	0.0	0.0	39.3	92.3	100
QP	610.2	48.2	-4.5	0.0	0.0	43.7	153.1	200
QP	583.1	47.3	-4.6	0.0	0.0	42.7	136.5	200
QP	434.0	49.2	-7.9	0.0	0.0	41.3	116.1	200
QP	42.2	47.5	-13.1	0.0	0.0	34.4	52.5	100
QP	461.1	47.6	-7.5	0.0	0.0	40.1	101.2	200
QP	179.0	50.3	-16.1	0.0	0.0	34.2	51.3	150
QP	355.3	46.1	-10.0	0.0	0.0	36.1	63.8	200

## 13 AC power-line conducted emissions

### 13.1 Definition

Line-to-ground radio-noise voltage that is conducted from all of the EUT current-carrying power input terminals that are directly (or indirectly via separate transformers or power supplies) connected to a public power network.

### 13.2 Test Parameters

Test Location:	Element Hull
Test Chamber:	Lab 5 (screened room 2)
Test Standard and Clause:	ANSI C63.10-2013, Clause 6.2
EUT Frequencies Measured:	13.56 MHz
Deviations From Standard:	None
Measurement RBW:	9 kHz
Measurement Detectors:	Quasi-Peak and Average, RMS

### Environmental Conditions (Normal Environment)

Temperature: 20 °C	+15 °C to +35 °C (as declared)
Humidity: 47 % RH	20 % RH to 75 % RH (as declared)
Supply: 120 V ac	(as declared)

### 13.3 Test Limit

A radio apparatus that is designed to be connected to the public utility (AC) power line shall ensure that the radio frequency voltage, which is conducted back onto the AC power line on any frequency or frequencies within the band 150 kHz to 30 MHz, shall not exceed the limits in Table 3.

**Table 3 – AC Power Line Conducted Emission Limits**

Frequency (MHz)	Conducted limit (dB $\mu$ V)	
	Quasi-Peak	Average**
0.15 to 0.5	66 to 56*	56 to 46*
0.5 to 5	56	46
5 to 30	60	50

\*The level decreases linearly with the logarithm of the frequency.

\*\*A linear average detector is required.

### 13.4 Test Method

With the EUT setup in a screened room, as per section 9 of this report and connected as per Figure iii, the power line emissions were measured on a spectrum analyzer / EMI receiver.

AC power line conducted emissions from the EUT are checked first by preview scans with peak and average detectors covering both live and neutral lines. A spectrum analyzer is used to determine if any periodic emissions are present.

Formal measurements using the correct detector(s) and bandwidth are made on frequencies identified from the preview scans. Final measurements were performed with EUT set at its maximum duty in transmit and receive modes.

**Figure iii Test Setup**

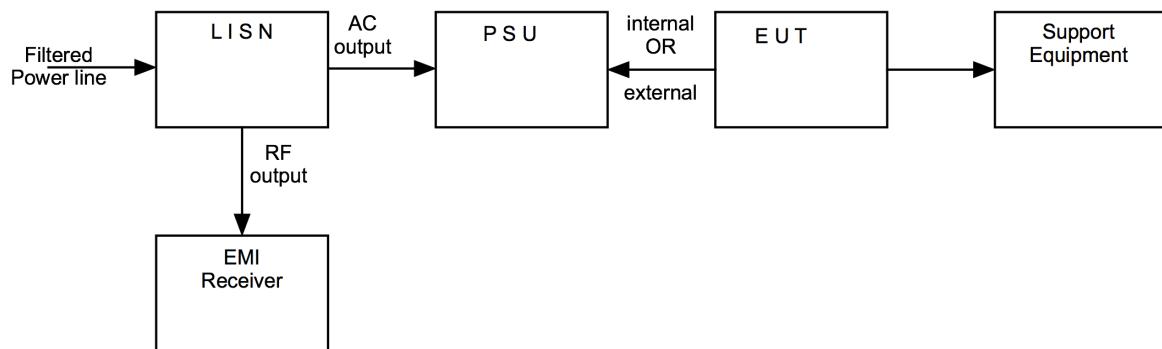

### 13.5 Test Set-up Photograph

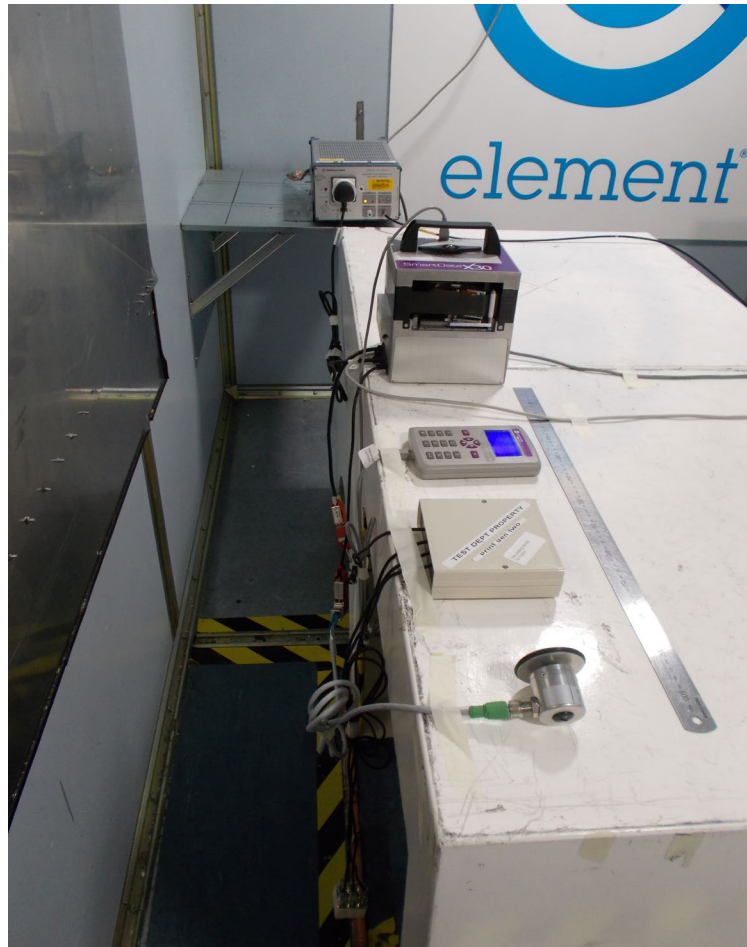

Note: the 60 cm long metal ruler is for scale purposes and was removed during testing.

### 13.6 Test Equipment

Equipment Type	Manufacturer	Equipment Description	Element No	Due For Calibration
ESC17	R&S	Measuring Receiver	RFG715	2022-03-29
ESH3-Z2	R&S	Pulse Limiter	RFG680	2022-06-09
SCREENED ROOM	Belling Lee Intec Ltd	Screened room 2	RFG205	N/A
8559	IR Group	500VA frequency converter	RFG109	N/A
ESH3-Z5	R&S	LISN	RFG732	2022-05-18
CNE III	York EMC	CNE	RFG638	N/A

### 13.7 Test Results

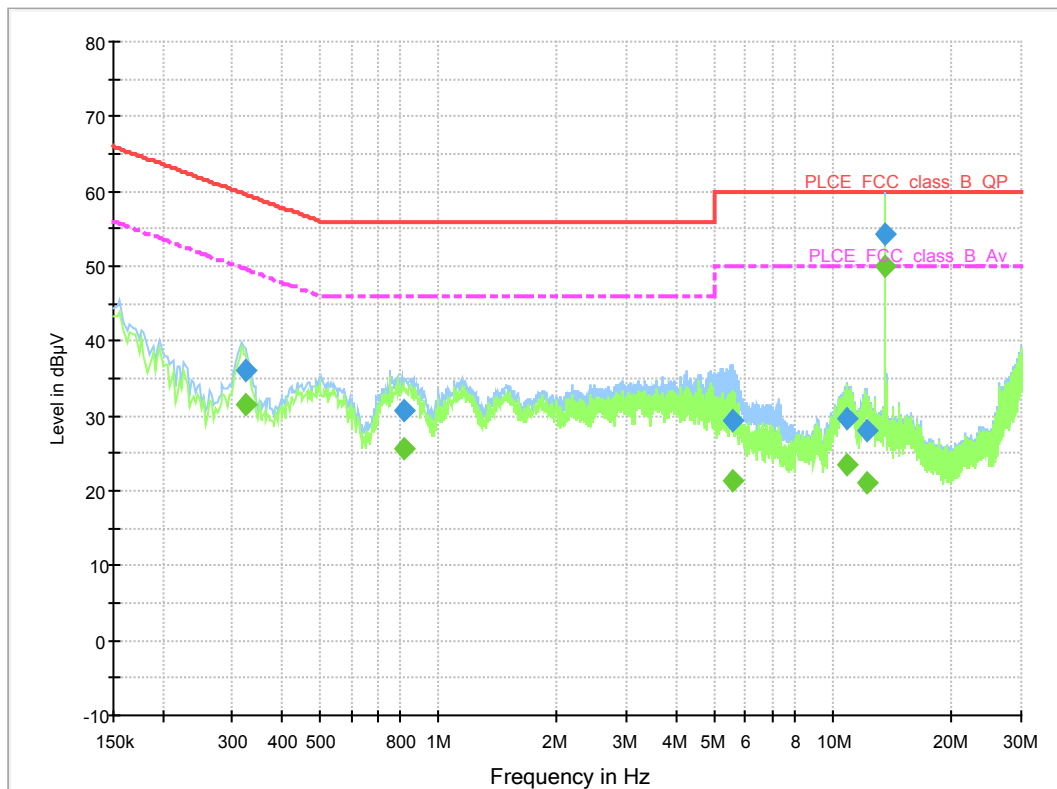

#### AC power-line conducted emissions, Transmit mode

Frequency (MHz)	QuasiPeak (dBµV)	Meas. Time (ms)	Bandwidth (kHz)	PE	Line	Corr. (dB)	Margin (dB)	Limit (dBµV)
0.322733	36.0	15000.0	9.000	GND	N	10.2	23.6	59.6
0.813365	30.8	15000.0	9.000	GND	N	10.2	25.2	56.0
5.596846	29.4	15000.0	9.000	GND	N	10.5	30.6	60.0
10.791848	29.8	15000.0	9.000	GND	N	10.8	30.2	60.0
12.144216	28.0	15000.0	9.000	GND	N	10.9	32.0	60.0
13.560144	54.2	15000.0	9.000	GND	N	11.0	5.8	60.0
Frequency (MHz)	Average (dBµV)	Meas. Time (ms)	Bandwidth (kHz)	PE	Line	Corr. (dB)	Margin (dB)	Limit (dBµV)
0.322733	31.6	15000.0	9.000	GND	N	10.2	18.1	49.6
0.813365	25.6	15000.0	9.000	GND	N	10.2	20.4	46.0
5.596846	21.3	15000.0	9.000	GND	N	10.5	28.7	50.0
10.791848	23.6	15000.0	9.000	GND	N	10.8	26.4	50.0
12.144216	21.2	15000.0	9.000	GND	N	10.9	28.8	50.0
13.560144	49.9	15000.0	9.000	GND	N	11.0	0.1	50.0

## 14 Occupied Bandwidth

### 14.1 Definition

#### *Occupied bandwidth*

The width of a frequency band such that, below the lower and above the upper frequency limits, the mean powers emitted are each equal to 0.5 % of the emitted power. This is also known as the 99 % *emission bandwidth*. For transmitters in which there are multiple carriers, contiguous or non-contiguous in frequency, the occupied bandwidth is to be the sum of the occupied bandwidths of the individual carriers.

#### *20 dB bandwidth*

The emission bandwidth (x dB) is defined as the frequency range between two points, one above and one below the carrier frequency, at which the spectral density of the emission is attenuated x dB below the maximum in-band spectral density of the modulated signal.

### 14.2 Test Parameters

Test Location:	Element Hull
Test Lab:	Wireless Lab 1
Test Standard and Clause:	ANSI C63.10-2013, Clause 6.9
EUT Frequency Measured:	13.56 MHz
Deviations From Standard:	None
Measurement BW:	10 kHz
Spectrum Analyzer Video BW:	30 kHz
Measurement Span:	200 kHz (note 1)
Measurement Detector:	Peak

### Environmental Conditions (Normal Environment)

Temperature: 20 °C	+15 °C to +35 °C (as declared)
Humidity: 60 % RH	20 % RH to 75 % RH (as declared)
Supply: 120 V ac	(as declared)

### 14.3 Test Limit

#### Federal Communications Commission:

Intentional radiators operating under the alternative provisions to the general emission limits, as contained in §§ 15.217 through 15.257 and in subpart E of this part, must be designed to ensure that the 20 dB bandwidth of the emission, or whatever bandwidth may otherwise be specified in the specific rule section under which the equipment operates, is contained within the frequency band designated in the rule section under which the equipment is operated.

#### Note 1:

The above signal was left to build up over a 20 minute period. The initially narrow signal was in-filled by a periodically modulated subcarrier from the EUT. It was impossible to measure a 20dB OBW with a 50 kHz span. An engineering decision was made to use a wider span and capture all the skirt of the signal hence 200 kHz was used.

#### 14.4 Test Method

With the EUT setup as per section 9 of this report and connected as per Figure iv, the bandwidth of the EUT was measured on a spectrum analyser.

The measurements were performed with EUT set at its maximum duty. All modulation schemes, data rates and power settings were used to observe the worst-case configuration in each bandwidth.

Figure iv Test Setup

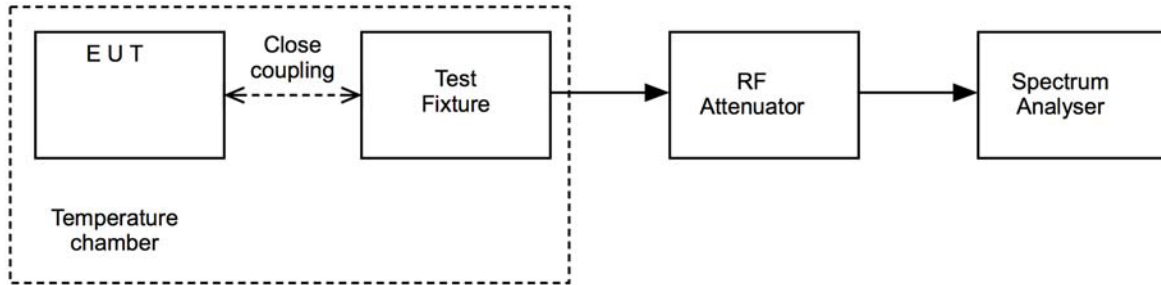

#### 14.5 Test Equipment

Equipment Type	Manufacturer	Equipment Description	Element No	Due For Calibration
ETC/JTS/2/01	JTS	Temperature Chamber	RFG365	Cal with REF2110
EMI Test Receiver	R&S	ESW26	REF2235	2022-10-05
53 II B	Fluke	Thermometer	REF2110	2022-08-31
34405A	Agilent	Multimeter	REF887	2022-10-12
-	-	Loop Coil	RFG408	Cal in use

#### 14.6 Test Results

FCC 15.225, Frequency: 13.56 MHz			
Channel Frequency (MHz)	$\Delta F_L$ (kHz)	$\Delta F_H$ (kHz)	20 dB Bandwidth (kHz)
13.56	-62.706	63.437	126.143

20dB Occupied bandwidth plot

Element

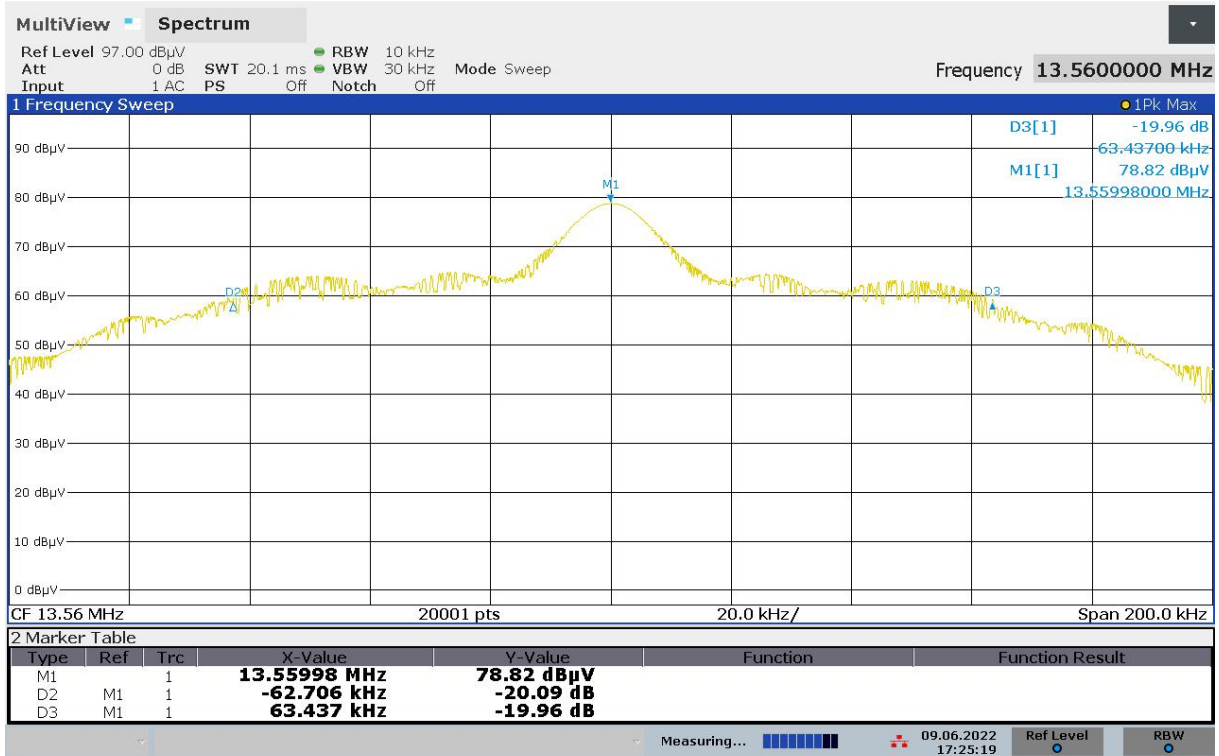

17:25:20 09.06.2022



## 15 Transmitter output power (fundamental radiated emission)

### 15.1 Definition

The RF power dissipated in the standard output termination when operating under the rated duty cycle selected by the applicant for approval.

### 15.2 Test Parameters

Test Location:	Element Hull
Test Chamber:	Wireless Lab 3
Test Antenna:	Active 60cm loop
Test Standard and Clause:	ANSI C63.10-2013, Clause 6.3 / 6.4
Frequencies Measured:	13.56 MHz
Deviations From Standard:	None
Measurement BW:	9 kHz
Spectrum Analyzer Video BW: (requirement at least 3x RBW)	30 kHz
Measurement Detector:	Quasi-peak
Voltage Extreme Environment Test Range:	Mains Power = 85% and 115% of Nominal (FCC only requirement);

### Environmental Conditions (Normal Environment)

Temperature: 24 °C	+15 °C to +35 °C (as declared)
Humidity: 42 % RH	20 % RH to 75 % RH (as declared)

### 15.3 Test Limit

The field strength measured at 30 m shall not exceed the limits in the following table:

**Field Strength Limits for License-Exempt Transmitters for Any Application**

<i>Frequency range (MHz)</i>	<i>Field strength (μV/m at 30m)</i>	<i>Field strength (dBμV/m at 30m)</i>
13.110 – 13.410	106	40.5
13.410 – 13.553	334	50.5
13.553 – 13.567	15,848	84.0
13.567 – 13.710	334	50.5
13.710 – 14.010	106	40.5

## 15.4 Test Method

With the EUT setup as per section 9 of this report and connected as per Figure v, the resolution bandwidth of the spectrum analyser was increased above the EUT occupied bandwidth and the peak emission data noted.

The measurements were performed with EUT set at its maximum duty. All modulation schemes, data rates and power settings were used to observe the worst-case configuration in each bandwidth.

Power values measured on the test receiver / analyzer are converted to field strength, FS, in  $\mu\text{V}/\text{m}$  at the regulatory distance, using:

$$FS = 10^{(PR - CF) / 20}$$

Where,

PR is the power recorded on the receiver / spectrum analyzer in  $\text{dB}\mu\text{V}$  and includes any cable loss, antenna factor and pre-amplifier gain;

CF is the distance extrapolation factor in dB (where measurement distance different to limit distance);

Per FCC 47CFR15.31(f)(2) an extrapolation factor of 40 dB per decade was used for measurements at distances closer than specified.

This field strength value is then compared with the regulatory limit.

**Figure v Test Setup**

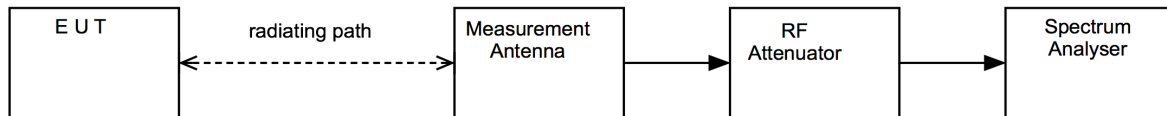

## 15.5 Test Equipment

Equipment Type	Manufacturer	Equipment Description	Element No	Due For Calibration
ATS	Rainford	Ferrite Lined Chamber	REF886	2022-07-29
N9030A	Agilent	Spectrum Analyser	REF2167	2022-08-25
6502	EMCO	Active Loop Antenna	R0079	2023-06-16
Emissions R5	Element	Radiated Test Software	REF9000	Cal not required
34405A	Agilent	Multimeter	REF887	2022-10-12
VVC	Zenith	Variable Voltage Control	REF1270	Cal with REF887

### 15.6 Test Results

Frequency: 13.56 MHz								
Channel Frequency (MHz)	Receiver Level (dBμV)	Factor (dB)	Measurement Distance (m)	Limit Distance (m)	Extrapolation Factor (dB)	Field Strength (dBμV/m)	Field Strength (μV/m)	Result
13.56 (Horizontal)	49.8	9.7	3	30	40	19.5	9.4	PASS
13.56 (Vertical)	48.3	9.7	3	30	40	18.0	7.9	PASS

Plot shows prescan for horizontal loop orientation with maximized QP data of the peak (round circles).

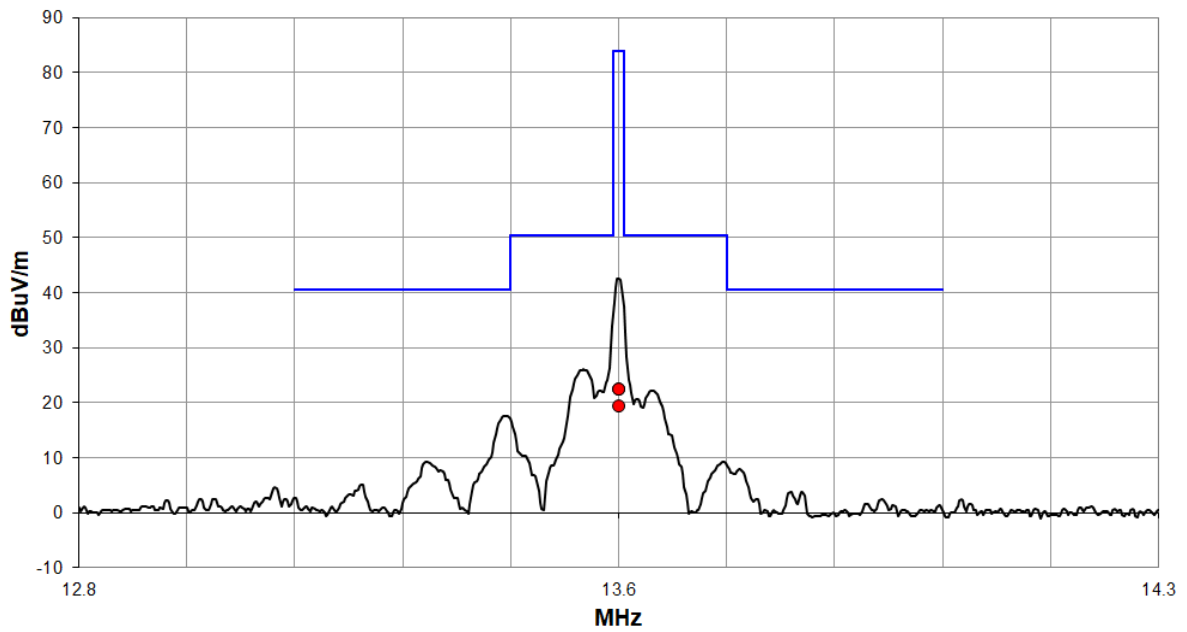

Plot shows prescan for vertical loop orientation with maximized QP data of the peak (round circles).

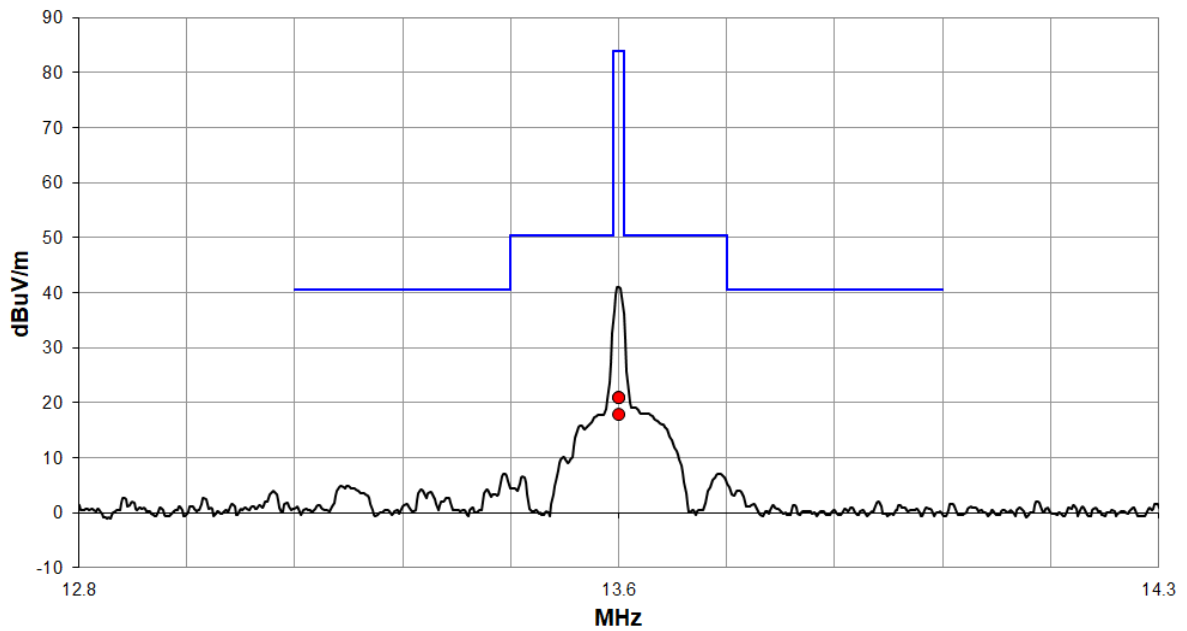

## 16 Frequency stability

### 16.1 Definition

Frequency stability is a measure of frequency drift due to temperature and supply voltage variations, with reference to the frequency measured at an appropriate reference temperature and the rated supply voltage.

### 16.2 Test Parameters

Test Location:	Element Hull
Test Chamber:	Wireless Lab 1
Test Standard and Clause:	ANSI C63.10-2013, Clause 6.8
EUT Frequency Measured:	13.56 MHz
Modulation:	Off
Deviations From Standard:	None
Temperature Extreme Environment Test Range:	-20 to +50 C
Voltage Extreme Environment Test Range:	Mains Power = $\pm 15\%$ of Nominal;

### Environmental Conditions (Normal Environment)

Temperature: 20 °C	Standard Requirement: +20 °C
Humidity: 60 %RH	20 % RH to 75 % RH (as declared)

### 16.3 Test Limit

Carrier frequency stability shall be maintained to  $\pm 0.01\%$  ( $\pm 100$  ppm).

### 16.4 Test Method

With the EUT setup as per section 9 of this report and connected as per Figure v, the frequency was measured under varying conditions of temperature and supply voltage.

The measurements were performed with EUT set in a CW mode of operation.

Measurements were made once temperature stability was achieved at each temperature.

**Figure v Test Setup**

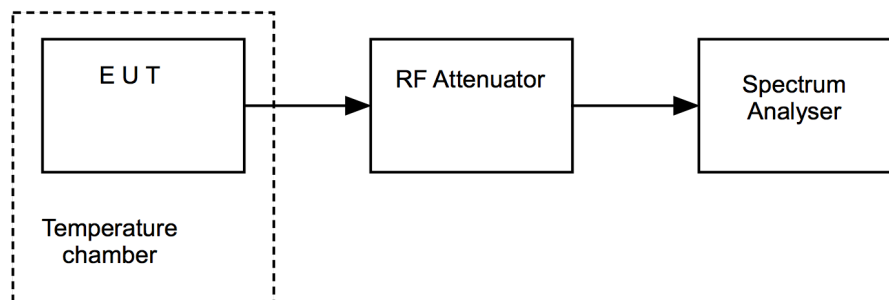

### 16.5 Test Equipment

Equipment Type	Manufacturer	Equipment Description	Element No	Due For Calibration
ETC/JTS/2/01	JTS	Temperature Chamber	RFG365	Cal with REF2110
N9030A	Agilent	Spectrum Analyser	REF2167	2022-08-25
53 II B	Fluke	Thermometer	REF2110	2022-08-31
34405A	Agilent	Multimeter	REF887	2022-10-12
VVC	Zenith	Variable Voltage Control	REF1270	Cal with REF887
		Loop Coil	RFG408	Cal in use

### 16.6 Test Results

<b>EUT Frequency: High</b>					
<b>Test Environment</b>		<b>Measured Frequency (MHz)</b>	<b>Frequency error (kHz)</b>	<b>Limit (kHz)</b>	<b>Result</b>
-20 C	V <sub>nominal</sub>	13.5601000	0.1000	±1.356	PASS
-10 C	V <sub>nominal</sub>	13.5601000	0.1000	±1.356	PASS
0 C	V <sub>nominal</sub>	13.5601000	0.1000	±1.356	PASS
+10 C	V <sub>nominal</sub>	13.5601000	0.1000	±1.356	PASS
+20 C	V <sub>minimum</sub>	13.5600995	0.0995	±1.356	PASS
	V <sub>nominal</sub>	13.5601000	0.1000	±1.356	PASS
	V <sub>maximum</sub>	13.5601000	0.1000	±1.356	PASS
+30 C	V <sub>nominal</sub>	13.5600505	0.0505	±1.356	PASS
+40 C	V <sub>nominal</sub>	13.5600500	0.0500	±1.356	PASS
+50 C	V <sub>nominal</sub>	13.5599995	-0.0005	±1.356	PASS

## 17 Measurement Uncertainty

### Radio Testing – General Uncertainty Schedule

All statements of uncertainty are expanded standard uncertainty using a coverage factor of 1.96 to give a 95 % confidence where no required test level exists.

Test/Measurement	Budget Number	MU
<b>Conducted RF Power, Power Spectral Density, Adjacent Channel Power and Spurious emissions</b>		
Absolute RF power (via antenna connector) Dare RPR3006W Power Head	MU4001	<b>0.9 dB</b>
Carrier Power and PSD - Spectrum Analysers	MU4004	<b>0.9 dB</b>
Adjacent Channel Power	MU4002	<b>1.9 dB</b>
Transmitter conducted spurious emissions	MU4041	<b>0.9 dB</b>
Conducted power and spurious emissions 40 GHz to 50 GHz	MU4042	<b>2.4 dB</b>
Conducted power and spurious emissions 50 GHz to 75 GHz	MU4043	<b>2.5 dB</b>
Conducted power and spurious emissions 75 GHz to 110 GHz	MU4044	<b>2.4 dB</b>
<b>Radiated RF Power and Spurious emissions ERP and EIRP</b>		
Effective Radiated Power Reverb Chamber	MU4020	<b>3.7 dB</b>
Effective Radiated Power	MU4021	<b>4.7 dB</b>
TRP Emissions 30 MHz to 1 GHz using CBL6111 or CBL6112 Bilog Antenna	MU4046	<b>5.3 dB</b>
TRP Emissions 1 GHz to 18 GHz using HL050 Log Periodic Antenna	MU4047	<b>5.1 dB</b>
TRP Emissions 18 GHz to 26.5 GHz using Standard Gain Horn	MU4048	<b>2.7 dB</b>
TRP Emissions 26.5 GHz to 40 GHz using Standard Gain Horn	MU4049	<b>2.7 dB</b>
<b>Spurious Emissions Electric and Magnetic Field</b>		
Radiated Spurious Emissions 30 MHz to 1 GHz	MU4037	<b>4.7 dB</b>
Radiated Spurious Emissions 1-18 GHz	MU4032	<b>4.5 dB</b>
E Field Emissions 18GHz to 26 GHz	MU4024	<b>3.2 dB</b>
E Field Emissions 26GHz to 40 GHz	MU4025	<b>3.3 dB</b>
E Field Emissions 40GHz to 50 GHz	MU4026	<b>3.5 dB</b>
E Field Emissions 50GHz to 75 GHz	MU4027	<b>3.6 dB</b>
E Field Emissions 75GHz to 110 GHz	MU4028	<b>3.6 dB</b>
Radiated Magnetic Field Emissions	MU4031	<b>2.3 dB</b>
<b>Frequency Measurements</b>		
Frequency Deviation	MU4022	<b>0.316 kHz</b>
Frequency error using CMTA test set	MU4023	<b>113.441 Hz</b>
Frequency error using GPS locked frequency source	MU4045	<b>0.0413 ppm</b>
<b>Bandwidth/Spectral Mask Measurements</b>		
Channel Bandwidth	MU4005	<b>3.87 %</b>
Transmitter Mask Amplitude	MU4039	<b>1.3 dB</b>
Transmitter Mask Frequency	MU4040	<b>2.59 %</b>
<b>Time Domain Measurements</b>		
Transmission Time	MU4038	<b>4.40 %</b>
<b>Dynamic Frequency Selection (DFS) Parameters</b>		
DFS Analyser - Measurement Time	MU4006	<b>679 µs</b>
DFS Generator - Frequency Error	MU4007	<b>92 Hz</b>
DFS Threshold Conducted	MU4008	<b>1.3 dB</b>
DFS Threshold Radiated	MU4009	<b>3.2 dB</b>

<b>Test/Measurement</b>	<b>Budget Number</b>	<b>MU</b>
<b>Receiver Parameters</b>		
EN300328 Receiver Blocking	MU4010	<b>1.1 dB</b>
EN301893 Receiver Blocking	MU4011	<b>1.1 dB</b>
EN303340 Adjacent Channel Selectivity	MU4012	<b>1.1 dB</b>
EN303340 Overloading	MU4013	<b>1.1 dB</b>
EN303340 Receiver Blocking	MU4014	<b>1.1 dB</b>
EN303340 Receiver Sensitivity	MU4015	<b>0.9 dB</b>
EN303372-1 Image Rejection	MU4016	<b>1.4 dB</b>
EN303372-1 Receiver Blocking	MU4017	<b>1.1 dB</b>
EN303372-2 Adjacent Channel Selectivity	MU4018	<b>1.1 dB</b>
EN303372-2 Dynamic Range	MU4019	<b>0.9 dB</b>
Receiver Blocking Talk Mode Conducted	MU4033	<b>1.2 dB</b>
Receiver Blocking Talk Mode- radiated	MU4034	<b>3.4 dB</b>
Rx Blocking, listen mode, blocking level	MU4035	<b>3.2 dB</b>
Rx Blocking, listen mode, radiated Threshold Measurement	MU4036	<b>3.4 dB</b>
Adjacent Sub Band Selectivity	MU4003	<b>4.2 dB</b>

## 18 RF Exposure

### KDB 447498 – USA limits

#### Section 4.3 General SAR test reduction and exclusion guidance

For Standalone SAR exclusion consideration, when SAR Exclusion Threshold requirement in KDB 447498 is satisfied, standalone SAR evaluation for general population exposure conditions by measurement or numerical simulation is not required.

The SAR Test Exclusion Threshold for frequencies in the range 100 MHz to 6 GHz, and for test separation distance of  $\leq 50$  mm, is determined as follows.

$$\text{SAR Exclusion Threshold (SARET)} = (\text{NT} \times \text{TSD}_A) / \sqrt{f_{\text{GHz}}}$$

Where,

NT = Numeric Threshold (3.0 for 1-g SAR and 7.5 for 10-g SAR)

TSD<sub>A</sub> = Minimum Test separation distance or 50 mm (whichever is lower)

f<sub>GHz</sub> = Transmit frequency in GHz

<i>Channel Frequency (MHz)</i>	<i>Maximum EIRP Power (mW)</i>	<i>SAR Exclusion Threshold at 10 mm (mW)</i>	<i>SAR Evaluation</i>
13.56	1.63 x 10 <sup>-8</sup>	443.0	Not Required

Therefore standalone SAR evaluation for general population exposure conditions by measurement or numerical simulation is not required.