

## TEST REPORT

**Report No.: 20030538HKG-001**

Waverly Labs Inc.

Application For Certification  
(Original Grant)

**FCC ID: 2AN4B-AMBASSADORI1**

**IC: 23324-AMBASSADOR1**

Transceiver

**Prepared and Checked by:**

**Approved by:**

Signed On File  
Wong Cheuk Ho, Herbert  
Lead Engineer

---

Wong Kwok Yeung, Kenneth  
Senior Lead Engineer  
Date: April 17, 2020

---

Intertek's standard Terms and Conditions can be obtained at our website <http://www.intertek.com/terms/>.

The test report only allows to be revised within the retention period unless further standard or the requirement was noticed.

This report is for the exclusive use of Intertek's Client and is provided pursuant to the agreement between Intertek and its Client. Intertek's responsibility and liability are limited to the terms and conditions of the agreement. Intertek assumes no liability to any party, other than to the Client in accordance with the agreement, for any loss, expense or damage occasioned by the use of this report. Only the Client is authorized to permit copying or distribution of this report and then only in its entirety. Any use of the Intertek name or one of its marks for the sale or advertisement of the tested material, product or service must first be approved in writing by Intertek. The observations and test results in this report are relevant only to the sample tested. This report by itself does not imply that the material, product, or service is or has ever been under an Intertek certification program.

© 2017 Intertek

## TEST REPORT

### GENERAL INFORMATION

<b>Grantee:</b>	Waverly Labs Inc.
<b>Grantee Address:</b>	19 Morris Ave Brooklyn New York 11205 United States
<b>Contact Person:</b>	Sergio Del Río Díaz
<b>Tel:</b>	+1 646-480-2644
<b>Fax:</b>	N/A
<b>e-mail:</b>	sergio@waverlylabs.com
<b>Manufacturer:</b>	Dongguan Kwan Hong Electronics Co., Ltd.
<b>Manufacturer Address:</b>	No. 5, Shichangxiang, Chang'an Town, Dongguan City, Guangdong Province, China
<b>Brand Name:</b>	Waverly Labs
<b>Model / HVIN:</b>	Ambassador i1
<b>PMN:</b>	Ambassador Earpiece
<b>Type of EUT:</b>	Transceiver
<b>Description of EUT:</b>	Ambassador Interpreter Earpiece
<b>Serial Number:</b>	N/A
<b>FCC ID / IC:</b>	2AN4B-AMBASSADORI1 / 23324-AMBASSADOR1
<b>Date of Sample Submitted:</b>	March 12, 2020
<b>Date of Test:</b>	March 12, 2020 to April 10, 2020
<b>Report No.:</b>	20030538HKG-001
<b>Report Date:</b>	April 17, 2020
<b>Environmental Conditions:</b>	Temperature: +10 to 40°C Humidity: 10 to 90%
<b>Conclusion:</b>	Test was conducted by client submitted sample. The submitted sample as received complied with the 47 CFR Part 15 / RSS-210 Issue 10 Certification.

**TEST REPORT**

**SUMMARY OF TEST RESULT**

Test Specification	Reference	Results
Transmitter Power Line Conducted Emissions	15.207 / RSS-Gen 8.8	Pass
Radiated Emission Radiated Emission on the Bandedge	15.249, 15.209 / RSS-210 B.10, RSS-210 4.4	Pass
Radiated Emission in Restricted Bands	15.205 / RSS-210 4.1	Pass

The equipment under test is found to be complying with the following standards:

- FCC Part 15, October 1, 2018 Edition
- RSS-210 Issue 10, December 2019
- RSS-Gen Issue 5 Amendment 1, March 2019

Note: 1. The EUT uses a permanently attached antenna which, in accordance to section 15.203, is considered sufficient to comply with the provisions of this section.  
2. Pursuant to FCC part 15 Section 15.215(c), the 20 dB bandwidth of the emission was contained within the frequency band designated (mentioned as above) which the EUT operated. The effects, if any, from frequency sweeping, frequency hopping, other modulation techniques and frequency stability over excepted variations in temperature and supply voltage were considered.

**TEST REPORT**

**TABLE OF CONTENTS**

**1.0 GENERAL DESCRIPTION ..... 5**

    1.1 Product Description .....5

    1.2 Related Submittal(s) Grants .....5

    1.3 Test Methodology.....5

    1.4 Test Facility .....5

**2.0 SYSTEM TEST CONFIGURATION..... 6**

    2.1 Justification.....6

    2.2 EUT Exercising Software .....6

    2.3 Special Accessories .....6

    2.4 Measurement Uncertainty .....6

    2.5 Support Equipment List and Description.....6

**3.0 EMISSION RESULTS ..... 7**

    3.1 Field Strength Calculation .....7

    3.2 Radiated Emission Configuration Photograph .....8

    3.3 Radiated Emission Data .....8

    3.4 Conducted Emission Configuration Photograph .....8

    3.5 Conducted Emission Data .....8

**4.0 EQUIPMENT PHOTOGRAPHS ..... 14**

**5.0 PRODUCT LABELLING ..... 14**

**6.0 TECHNICAL SPECIFICATIONS ..... 14**

**7.0 INSTRUCTION MANUAL..... 14**

**8.0 MISCELLANEOUS INFORMATION ..... 15**

    8.1 Measured Bandwidth / Radiated Emission on the Bandedge .....15

    8.2 Discussion of Pulse Desensitization.....18

    8.3 Calculation of Average Factor .....18

    8.4 Emissions Test Procedures.....19

    8.5 Occupied Bandwidth.....23

**9.0 CONFIDENTIALITY REQUEST ..... 24**

**10.0 EQUIPMENT LIST..... 24**

## TEST REPORT

### 1.0 GENERAL DESCRIPTION

#### 1.1 Product Description

The Equipment Under Test (EUT) is an Ambassador Interpreter Earpiece which operates at frequency range of 2402MHz to 2480MHz. When the EUT pairs with a smartphone apps with Bluetooth feature, up to 4 users can use the language translation function on the smartphone apps.

Only one person can wear one EUT at a time. The EUT is designed for the right ear where the users will hear the translation.

The Bluetooth feature in the EUT is operating in the frequency range from 2402MHz to 2480MHz (79 channels 1MHz channel spacing). The applicant declared that Bluetooth BLE is not used.

The EUT is powered by an internal 3.7V rechargeable battery. The USB port is for charging internal battery purpose only.

Antenna Type: Internal, Integral

For electronic filing, the brief circuit description is saved with filename: descri.pdf.

#### 1.2 Related Submittal(s) Grants

This is a single application for certification of a transceiver.

#### 1.3 Test Methodology

Both AC mains line-conducted and radiated emission measurements were performed according to the procedures in ANSI C63.10 (2013). All radiated measurements were performed in an 3m Chamber. Preliminary scans were performed in the 3m Chamber only to determine worst case modes. All radiated tests were performed at an antenna to EUT distance of 3 meters, unless stated otherwise in the “**Justification Section**” of this Application.

#### 1.4 Test Facility

The 3m Chamber and conducted measurement facility used to collect the radiated data is located at Workshop No. 3, G/F., World-Wide Industrial Centre, 43-47 Shan Mei Street, Fo Tan, Sha Tin, N.T., Hong Kong SAR, China. This test facility and site measurement data have been placed on file with the FCC and IC No. 2042H.

## TEST REPORT

### 2.0 SYSTEM TEST CONFIGURATION

#### 2.1 Justification

The system was configured for testing in a typical fashion (as a customer would normally use it), and in the confines as outlined in ANSI C63.10 (2013).

The device was powered by USB Port of 5VDC and/or 3.7V Rechargeable Battery. Both powering methods were tested. Only the worse case is shown in this report (powered by USB port).

For maximizing emissions, the EUT was rotated through 360°, the antenna height was varied from 1 meter to 4 meters above the ground plane, and the antenna polarization was changed. This step by step procedure for maximizing emissions led to the data reported in Exhibit 3.0.

The rear of unit shall be flushed with the rear of the table.

The equipment under test (EUT) was configured for testing in a typical fashion (as a customer would normally use it). The EUT was mounted to a plastic stand if necessary and placed on the wooden turntable, which enabled the engineer to maximize emissions through its placement in the three orthogonal axes.

All connecting cables of EUT and peripherals were manipulated to find the maximum emission

#### 2.2 EUT Exercising Software

The EUT exercise program (if any) used during radiated testing was designed to exercise the various system components in a manner similar to a typical use.

#### 2.3 Special Accessories

There are no special accessories necessary for compliance of this product.

#### 2.4 Measurement Uncertainty

When determining of the test conclusion, the Measurement Uncertainty of test has been considered.

Uncertainty and Compliance - Unless the standard specifically states that measured values are to be extended by the measurement uncertainty in determining compliance, all compliance determinations are based on the actual measured value.

#### 2.5 Support Equipment List and Description

1. HP Notebook Computer (Adaptor Model: HSTNN-CA15)
2. 1 x LAN cable of 2m long  
(Provided by Intertek)
3. 1 x USB cable of 0.4m long  
(Provided by Applicant)

## TEST REPORT

### 3.0 EMISSION RESULTS

Data is included of the worst case configuration (the configuration which resulted in the highest emission levels). A sample calculation, configuration photographs and data tables of the emissions are included.

#### 3.1 Field Strength Calculation

The field strength is calculated by adding the Antenna Factor and Cable Factor, and subtracting the Amplifier Gain (if any), Average Factor (optional) from the measured reading. The basic equation with a sample calculation is as follows:

$$FS = RA + AF + CF - AG - AV$$

where FS = Field Strength in dB $\mu$ V/m

RA = Receiver Amplitude (including preamplifier) in dB $\mu$ V

CF = Cable Attenuation Factor in dB

AF = Antenna Factor in dB

AG = Amplifier Gain in dB

AV = Average Factor in dB

In the following table(s), the reading shown on the data table reflects the preamplifier gain. An example for the calculations in the following table is as follows:

$$FS = RR + LF$$

where FS = Field Strength in dB $\mu$ V/m

RR = RA - AG - AV in dB $\mu$ V

LF = CF + AF in dB

Assume a receiver reading of 52.0 dB $\mu$ V is obtained. The antenna factor of 7.4 dB and cable factor of 1.6 dB are added. The amplifier gain of 29 dB and average factor of 5 dB are subtracted, giving a field strength of 27 dB $\mu$ V/m. This value in dB $\mu$ V/m was converted to its corresponding level in  $\mu$ V/m.

$$RA = 52.0 \text{ dB}\mu\text{V/m}$$

$$AF = 7.4 \text{ dB}$$

$$CF = 1.6 \text{ dB}$$

$$AG = 29.0 \text{ dB}$$

$$AV = 5.0 \text{ dB}$$

$$FS = RR + LF$$

$$FS = 18 + 9 = 27 \text{ dB}\mu\text{V/m}$$

$$RR = 18.0 \text{ dB}\mu\text{V}$$

$$LF = 9.0 \text{ dB}$$

$$\text{Level in } \mu\text{V/m} = \text{Common Antilogarithm } [(27 \text{ dB}\mu\text{V/m})/20] = 22.4 \mu\text{V/m}$$

## TEST REPORT

### 3.2 Radiated Emission Configuration Photograph

The worst case in radiated emission was found at 4960 MHz

For electronic filing, the worst case radiated emission configuration photographs are saved with filename: radiated photos.pdf.

### 3.3 Radiated Emission Data

The data on the following page lists the significant emission frequencies, the limit and the margin of compliance. Numbers with a minus sign are below the limit.

Judgment: Passed by 0.6 dB

### 3.4 Conducted Emission Configuration Photograph

The worst case in line-conducted emission was found at 0.155 MHz

For electronic filing, the worst-case line-conducted configuration photographs are saved with filename: conducted photo.pdf.

### 3.5 Conducted Emission Data

For electronic filing, the graph and data table of conducted emission is saved with filename: conducted.pdf.

Judgment: Pass by 7.9 dB



**TEST REPORT**

**CONDUCTED EMISSION**

Model/HVIN: Ambassador i1

Date of Test: April 10, 2020

Worst-Case Operating Mode: Bluetooth operating

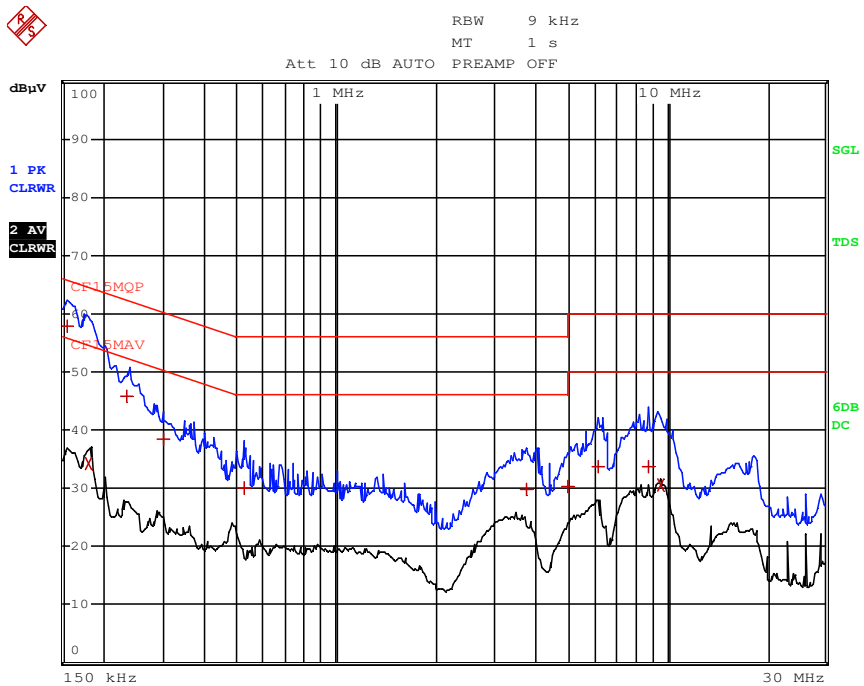

**EDIT PEAK LIST (Final Measurement Results)**

Trace1: CF15MQP  
Trace2: CF15MAV  
Trace3: ---

TRACE	FREQUENCY	LEVEL dBµV	DELTA	LIMIT dB
1 Quasi Peak	154.5 kHz	57.83	N	-7.91
2 CISPR Average	181.5 kHz	34.16	L1	-20.24
1 Quasi Peak	235.5 kHz	45.87	L1	-16.37
1 Quasi Peak	298.5 kHz	38.39	L1	-21.89
1 Quasi Peak	523.5 kHz	30.15	L1	-25.84
1 Quasi Peak	3.7455 MHz	29.84	L1	-26.15
1 Quasi Peak	4.974 MHz	30.22	N	-25.77
1 Quasi Peak	6.153 MHz	33.83	L1	-26.16
1 Quasi Peak	8.754 MHz	33.79	N	-26.20
2 CISPR Average	9.528 MHz	30.54	L1	-19.45

Note: Measurement Uncertainty is ±4.2dB at a level of confidence of 95%.

**TEST REPORT**

**RADIATED EMISSIONS**

Model/HVIN: Ambassador i1

Date of Test: April 10, 2020

Worst-Case Operating Mode: Transmitting

Table 1  
Pursuant to FCC Part 15 Section 15.249 / RSS-210 B10.0 Requirement

Lowest Channel

Polarization	Frequency (MHz)	Reading (dBµV)	Pre-Amp Gain (dB)	Antenna Factor (dB)	Net at 3m - Peak (dBµV/m)	Average Limit at 3m (dBµV/m)	Margin (dB)
H	2402.000	62.0	33	29.4	58.4	94.0	-35.6
<b>H</b>	<b>4804.000</b>	<b>34.9</b>	<b>33</b>	<b>34.9</b>	<b>36.8</b>	<b>54.0</b>	<b>-17.2</b>
H	7206.000	33.9	33	37.9	38.8	54.0	-15.2
H	9608.000	23.0	33	40.4	30.4	54.0	-23.6
<b>H</b>	<b>12010.000</b>	<b>29.3</b>	<b>33</b>	<b>40.5</b>	<b>36.8</b>	<b>54.0</b>	<b>-17.2</b>
H	14412.000	25.4	33	40.0	32.4	54.0	-21.6

Polarization	Frequency (MHz)	Reading (dBµV)	Pre-Amp Gain (dB)	Antenna Factor (dB)	Net at 3m - Peak (dBµV/m)	Peak Limit at 3m (dBµV/m)	Margin (dB)
H	2402.000	103.2	33	29.4	99.6	114.0	-14.4
<b>H</b>	<b>4804.000</b>	<b>66.7</b>	<b>33</b>	<b>34.9</b>	<b>68.6</b>	<b>74.0</b>	<b>-5.4</b>
H	7206.000	55.7	33	37.9	60.6	74.0	-13.4
H	9608.000	45.4	33	40.4	52.8	74.0	-21.2
<b>H</b>	<b>12010.000</b>	<b>49.9</b>	<b>33</b>	<b>40.5</b>	<b>57.4</b>	<b>74.0</b>	<b>-16.6</b>
H	14412.000	47.8	33	40.0	54.8	74.0	-19.2

- NOTES:
1. Peak Detector Data unless otherwise stated. Average measurement method is according to ANSI C63.10.
  2. All measurements were made at 3 meters. Harmonic emissions not detected at the 3-meter distances were measured at 0.3-meter and an inverse proportional extrapolation was performed to compare the signal level to the 3-meter limit. No other harmonic emissions than those reported were detected at a test distance of 0.3-meter.
  3. Negative sign in the column shows value below limit.
  4. Horn antenna is used for the emission over 1000MHz.
  5. Emission (the row indicated by **bold italic**) within the restricted band meets the requirement of FCC Part 15 Section 15.205 / RSS-210 4.1.
  6. Measurement Uncertainty is ±5.3dB at a level of confidence of 95%.

**TEST REPORT**

Model/HVIN: Ambassador i1  
Date of Test: April 10, 2020  
Worst-Case Operating Mode: Transmitting

Table 2  
Pursuant to FCC Part 15 Section 15.249 / RSS-210 B10.0 Requirement

Middle Channel

Polarization	Frequency (MHz)	Reading (dBµV)	Pre-Amp Gain (dB)	Antenna Factor (dB)	Net at 3m - Peak (dBµV/m)	Average Limit at 3m (dBµV/m)	Margin (dB)
H	2440.000	61.8	33	29.4	58.2	94.0	-35.8
<b>H</b>	<b>4880.000</b>	<b>34.3</b>	<b>33</b>	<b>34.9</b>	<b>36.2</b>	<b>54.0</b>	<b>-17.8</b>
<b>H</b>	<b>7320.000</b>	<b>29.3</b>	<b>33</b>	<b>37.9</b>	<b>34.2</b>	<b>54.0</b>	<b>-19.8</b>
H	9760.000	30.4	33	40.4	37.8	54.0	-16.2
<b>H</b>	<b>12200.000</b>	<b>29.3</b>	<b>33</b>	<b>40.5</b>	<b>36.8</b>	<b>54.0</b>	<b>-17.2</b>
H	14640.000	28.0	33	38.4	33.4	54.0	-20.6

Polarization	Frequency (MHz)	Reading (dBµV)	Pre-Amp Gain (dB)	Antenna Factor (dB)	Net at 3m - Peak (dBµV/m)	Peak Limit at 3m (dBµV/m)	Margin (dB)
H	2440.000	102.8	33	29.4	99.2	114.0	-14.8
<b>H</b>	<b>4880.000</b>	<b>65.9</b>	<b>33</b>	<b>34.9</b>	<b>67.8</b>	<b>74.0</b>	<b>-6.2</b>
<b>H</b>	<b>7320.000</b>	<b>60.9</b>	<b>33</b>	<b>37.9</b>	<b>65.8</b>	<b>74.0</b>	<b>-8.2</b>
H	9760.000	51.0	33	40.4	58.4	74.0	-15.6
<b>H</b>	<b>12200.000</b>	<b>50.7</b>	<b>33</b>	<b>40.5</b>	<b>58.2</b>	<b>74.0</b>	<b>-15.8</b>
H	14640.000	48.8	33	38.4	54.2	74.0	-19.8

- NOTES:
1. Peak Detector Data unless otherwise stated. Average measurement method is according to ANSI C63.10.
  2. All measurements were made at 3 meters. Harmonic emissions not detected at the 3-meter distances were measured at 0.3-meter and an inverse proportional extrapolation was performed to compare the signal level to the 3-meter limit. No other harmonic emissions than those reported were detected at a test distance of 0.3-meter.
  3. Negative sign in the column shows value below limit.
  4. Horn antenna is used for the emission over 1000MHz.
  5. Emission (the row indicated by **bold italic**) within the restricted band meets the requirement of FCC Part 15 Section 15.205 / RSS-210 4.1.
  6. Measurement Uncertainty is ±5.3dB at a level of confidence of 95%.

**TEST REPORT**

Model/HVIN: Ambassador i1  
Date of Test: April 10, 2020  
Worst-Case Operating Mode: Transmitting

Table 3  
Pursuant to FCC Part 15 Section 15.249 / RSS-210 B10.0 Requirement

Highest Channel

Polarization	Frequency (MHz)	Reading (dBμV)	Pre-Amp Gain (dB)	Antenna Factor (dB)	Net at 3m - Peak (dBμV/m)	Average Limit at 3m (dBμV/m)	Margin (dB)
H	2480.000	61.1	33	29.4	57.5	94.0	-36.5
<b>H</b>	<b>4960.000</b>	<b>34.6</b>	<b>33</b>	<b>34.9</b>	<b>36.5</b>	<b>54.0</b>	<b>-17.5</b>
<b>H</b>	<b>7440.000</b>	<b>27.9</b>	<b>33</b>	<b>37.9</b>	<b>32.8</b>	<b>54.0</b>	<b>-21.2</b>
H	9920.000	24.8	33	40.4	32.2	54.0	-21.8
<b>H</b>	<b>12400.000</b>	<b>23.3</b>	<b>33</b>	<b>40.5</b>	<b>30.8</b>	<b>54.0</b>	<b>-23.2</b>
H	14880.000	27.0	33	38.4	32.4	54.0	-21.6

Polarization	Frequency (MHz)	Reading (dBμV)	Pre-Amp Gain (dB)	Antenna Factor (dB)	Net at 3m - Peak (dBμV/m)	Peak Limit at 3m (dBμV/m)	Margin (dB)
H	2480.000	102.4	33	29.4	98.8	114.0	-15.2
<b>H</b>	<b>4960.000</b>	<b>71.5</b>	<b>33</b>	<b>34.9</b>	<b>73.4</b>	<b>74.0</b>	<b>-0.6</b>
<b>H</b>	<b>7440.000</b>	<b>59.3</b>	<b>33</b>	<b>37.9</b>	<b>64.2</b>	<b>74.0</b>	<b>-9.8</b>
H	9920.000	56.4	33	40.4	63.8	74.0	-10.2
<b>H</b>	<b>12400.000</b>	<b>44.7</b>	<b>33</b>	<b>40.5</b>	<b>52.2</b>	<b>74.0</b>	<b>-21.8</b>
H	14880.000	47.8	33	38.4	53.2	74.0	-20.8

- NOTES:
1. Peak Detector Data unless otherwise stated. Average measurement method is according to ANSI C63.10.
  2. All measurements were made at 3 meters. Harmonic emissions not detected at the 3-meter distances were measured at 0.3-meter and an inverse proportional extrapolation was performed to compare the signal level to the 3-meter limit. No other harmonic emissions than those reported were detected at a test distance of 0.3-meter.
  3. Negative sign in the column shows value below limit.
  4. Horn antenna is used for the emission over 1000MHz.
  5. Emission (the row indicated by **bold italic**) within the restricted band meets the requirement of FCC Part 15 Section 15.205 / RSS-210 4.1.
  6. Measurement Uncertainty is ±5.3dB at a level of confidence of 95%.

**TEST REPORT**

Model/HVIN: Ambassador i1  
Date of Test: April 10, 2020  
Worst-Case Operating Mode: Bluetooth operating

Table 4  
**Pursuant to FCC Part 15 Section 15.209 / RSS-210 4.4 Requirement**

Polarization	Frequency (MHz)	Reading (dBμV)	Pre-amp (dB)	Antenna Factor (dB)	Net at 3m (dBμV/m)	Limit at 3m (dBμV/m)	Margin (dB)
V	72.044	29.0	16	7.0	20.0	40.0	-20.0
H	107.998	29.5	16	14.0	27.5	43.5	-16.0
<b>V</b>	<b>129.934</b>	<b>37.5</b>	<b>16</b>	<b>14.0</b>	<b>35.5</b>	<b>43.5</b>	<b>-8.0</b>
H	337.975	27.2	16	24.0	35.2	46.0	-10.8
H	442.056	22.8	16	26.0	32.8	46.0	-13.2
H	675.992	30.8	16	29.0	43.8	46.0	-2.2
H	701.990	28.8	16	30.0	42.8	46.0	-3.2

- NOTES:
1. Quasi-Peak Detector Data unless otherwise stated.
  2. All measurements were made at 3 meters. Harmonic emissions not detected at the 3-meter distances were measured at 0.3-meter and an inverse proportional extrapolation was performed to compare the signal level to the 3-meter limit. No other harmonic emissions than those reported were detected at a test distance of 0.3-meter.
  3. Negative sign in the column shows value below limit.
  4. Horn antenna is used for the emission over 1000MHz.
  5. Emission (the row indicated by **bold italic**) within the restricted band meets the requirement of FCC Part 15 Section 15.205 / RSS-210 4.1.
  6. Measurement Uncertainty is ±5.3dB at a level of confidence of 95%.

## TEST REPORT

### 4.0 EQUIPMENT PHOTOGRAPHS

For electronic filing, the photographs are saved with filename: external photos.pdf and internal photos.pdf.

### 5.0 PRODUCT LABELLING

For electronics filing, the FCC ID label artwork and the label location are saved with filename: label.pdf.

### 6.0 TECHNICAL SPECIFICATIONS

For electronic filing, the block diagram and schematic of the tested EUT are saved with filename: block.pdf and circuit.pdf respectively.

### 7.0 INSTRUCTION MANUAL

For electronic filing, a preliminary copy of the Instruction Manual is saved with filename: manual.pdf.

This manual will be provided to the end-user with each unit sold/leased in the United States and Canada.

## TEST REPORT

### 8.0 MISCELLANEOUS INFORMATION

The miscellaneous information includes details of the test procedure and measured bandwidth / calculation of factor such as pulse desensitization and averaging factor (calculation and timing diagram).

#### 8.1 Radiated Emission on the Bandedge

From the following plots, they show that the fundamental emissions are confined in the specified band (2400MHz to 2483.5MHz). In case of the fundamental emissions are within two standard bandwidths from the bandedge, the delta measurement technique is used for determining bandedge compliance. Standard bandwidth is the bandwidth specified by ANSI C63.10 (2013) for frequency being measured.

Emissions radiated outside of the specified frequency bands, except harmonics, are attenuated by 50dB below the level of the fundamental or to the general radiated emissions limits in Section 15.209 / RSS-210 4.4, whichever is the lesser attenuation, which meet the requirement of part 15.249(d) / RSS-210 B.10.

**TEST REPORT**

**PEAK MEASUREMENT**

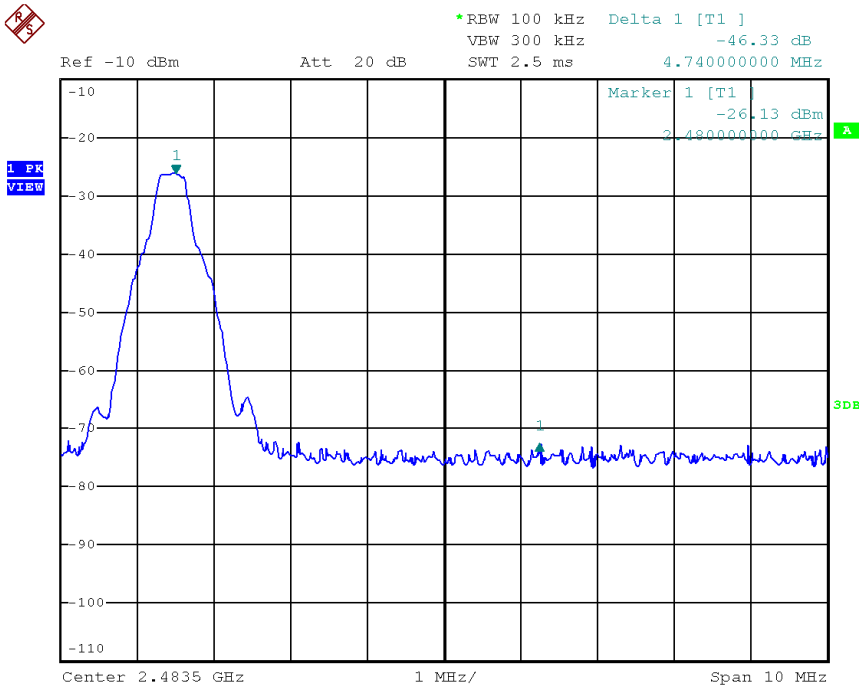
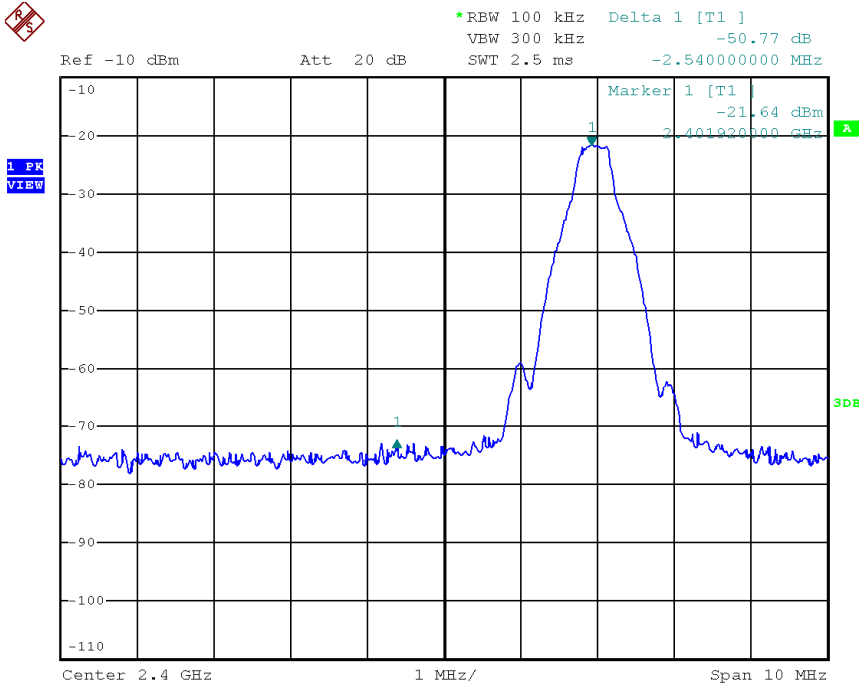



## TEST REPORT

### PEAK MEASUREMENT

Bandedge compliance is determined by applying marker-delta method, i.e. (Bandedge Plot).

Lower bandedge

Peak Resultant field strength = Fundamental emissions (peak value) – delta from the plot

=99.6 dB $\mu$ V/m – 50.8 dB

=48.8 dB $\mu$ V/m

Average Resultant field strength = Fundamental emissions (average value) – delta from the plot

=58.4 dB $\mu$ V/m – 50.8 dB

=7.6 dB $\mu$ V/m

Upper bandedge

Peak Resultant field strength = Fundamental emissions (peak value) – delta from the plot

=98.8 dB $\mu$ V/m – 46.3 dB

=52.5 dB $\mu$ V/m

Average Resultant field strength = Fundamental emissions (average value) – delta from the plot

=57.5 dB $\mu$ V/m - 46.3 dB

=11.2 dB $\mu$ V/m

The resultant field strength meets the general radiated emission limit in Section 15.209 / RSS-210 4.4, which does not exceed 74 dB $\mu$ V/m (Peak Limit) and 54 dB $\mu$ V/m (Average Limit).

## TEST REPORT

### 8.2 Discussion of Pulse Desensitization

Pulse desensitivity is not applicable for this device. The effective period ( $T_{eff}$ ) is approximately  $625\mu s$  for a digital "1" bit which illustrated on technical specification, with a resolution bandwidth (3dB) of 1MHz, so the pulse desensitivity factor is 0dB.

### 8.3 Calculation of Average Factor

N/A

## TEST REPORT

### 8.4 Emissions Test Procedures

The following is a description of the test procedure used by Intertek Testing Services Hong Kong Ltd. in the measurements of transmitter operating under the Part 15, Subpart C rules.

The transmitting equipment under test (EUT) is placed on a wooden turntable which is four feet in diameter and approximately 0.8m in height above the ground plane for emission measurement at or below 1GHz and 1.5m in height above the ground plane for emission measurement above 1GHz. During the radiated emissions test, the turntable is rotated and any cables leaving the EUT are manipulated to find the configuration resulting in maximum emissions. The EUT is adjusted through all three orthogonal axis to obtain maximum emission levels. The antenna height and polarization are also varied during the testing to search for maximum signal levels. The height of the antenna is varied from one to four meters.

Detector function for radiated emissions is in peak mode. Average readings, when required, are taken by measuring the duty cycle of the equipment under test and subtracting the corresponding amount in dB from the measured peak readings. A detailed description for the calculation of the average factor can be found in Exhibit 8.3.

The frequency range scanned is from the lowest radio frequency signal generated in the device which is greater than 9 kHz to the tenth harmonic of the highest fundamental frequency or 40 GHz, whichever is lower.

## TEST REPORT

### 8.4 Emissions Test Procedures (cont'd)

The EUT is warmed up for 15 minutes prior to the test.

AC power to the unit is varied from 85% to 115% nominal and variation in the fundamental emission field strength is recorded. If battery powered, a new, fully charged battery is used.

Conducted measurements were made as described in ANSI C63.10 (2013).

The IF bandwidth used for measurement of radiated signal strength was 100 kHz or greater when frequency is below 1000 MHz. Where pulsed transmissions of short enough pulse duration warrant, a greater bandwidth is selected according to the recommendations of Hewlett Packard Application Note 150-2. A discussion of whether pulse desensitivity is applicable to this unit is included in this report (See Exhibit 8.1). Above 1000 MHz, a resolution bandwidth of 3 MHz is used.

Transmitter measurements are normally conducted at a measurement distance of three meters. However, to assure low enough noise floor in the forbidden bands and above 1 GHz, signals are acquired at a distance of one meter or less. All measurements are extrapolated to three meters using inverse scaling, unless otherwise reported. Measurements taken at a closer distance are so marked.

## TEST REPORT

### 8.4.1 Radiated Emission Test Setup

The figure below shows the test setup, which is utilized to make these measurements.

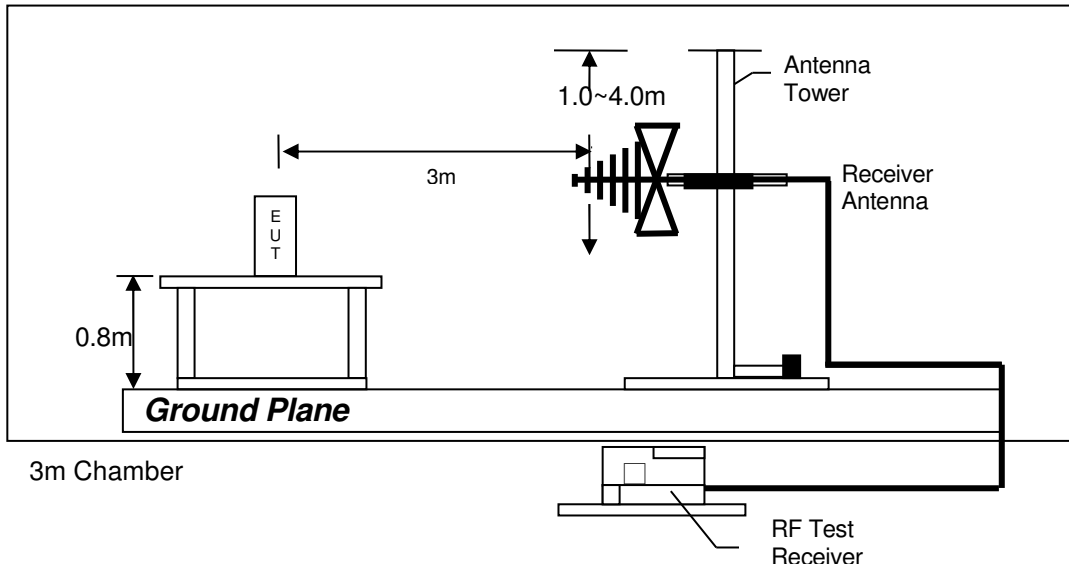

Test setup of radiated emissions up to 1GHz

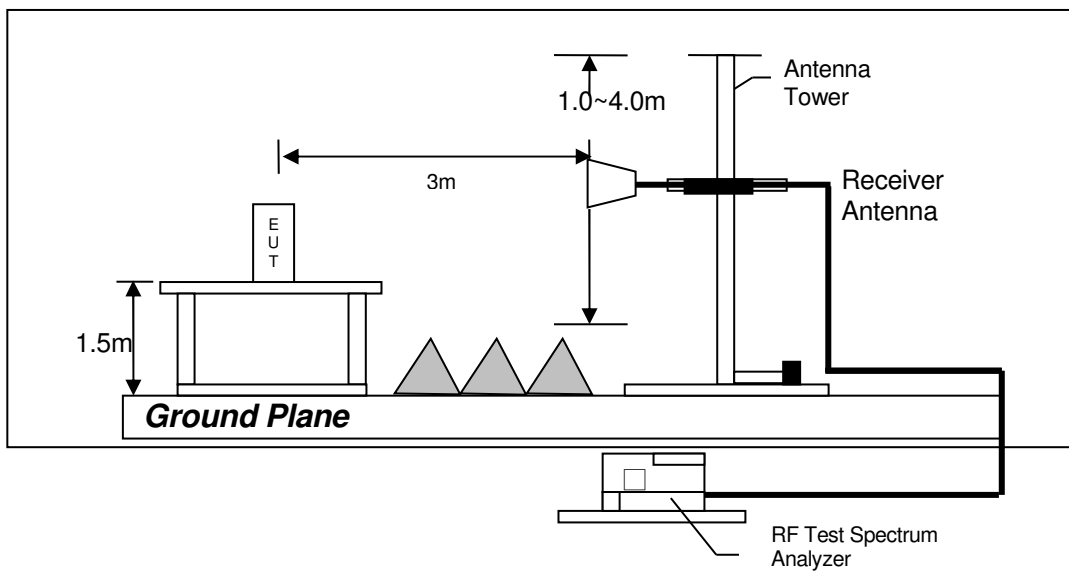

Test setup of radiated emissions above 1GHz

## TEST REPORT

### 8.4.2 Conducted Emission Test Procedures

For tabletop equipment, the EUT along with its peripherals were placed on a 1.0m(W)×1.5m(L) and 0.8m in height wooden table. For floor-standing equipment, the EUT and all cables were insulated, if required, from the ground plane by up to 12 mm of insulating material. The EUT was adjusted to maintain a 0.4 meter space from a vertical reference plane. The EUT was connected to power mains through a line impedance stabilization network (LISN), which provided 50 ohm coupling impedance for measuring instrument and the chassis ground was bounded to the horizontal ground plane of shielded room. The excess power cable between the EUT and the LISN was bundled.

All connecting cables of EUT and peripherals were moved to find the maximum emission.

### 8.4.3 Conducted Emission Test Setup

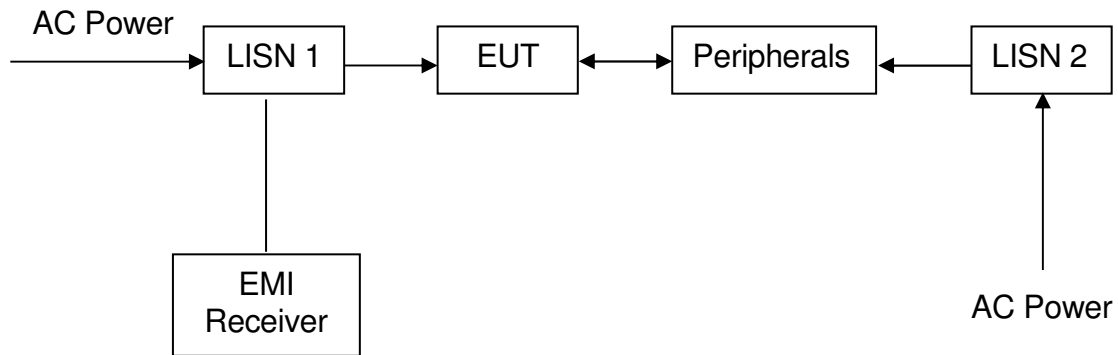

**TEST REPORT**

8.5 Occupied Bandwidth

Occupied Bandwidth Results:

Occupied Bandwidth (kHz)	
Low Channel: 2402	858
Middle Channel: 2440	852
High Channel: 2480	846

The worst case is shown as below

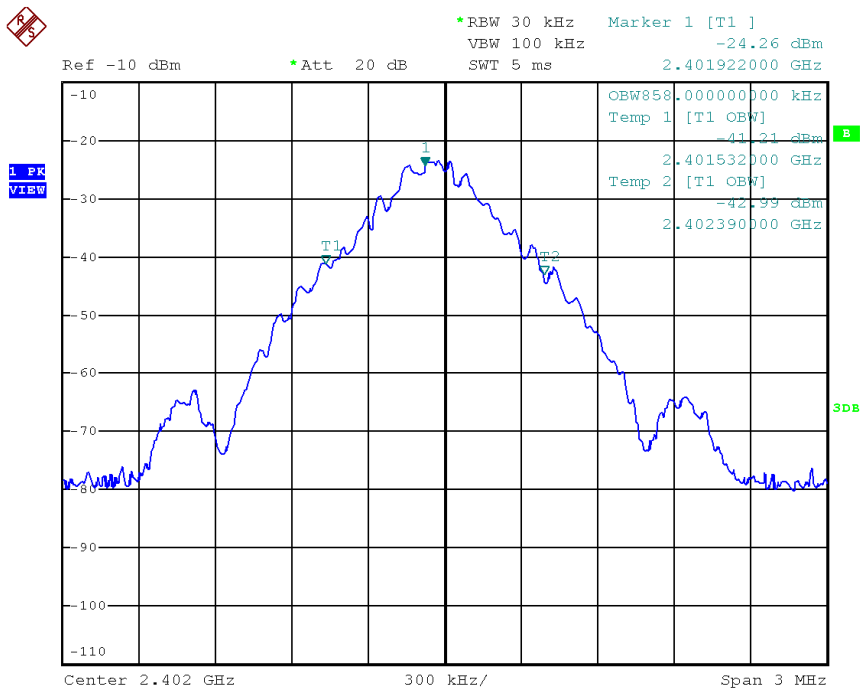

## TEST REPORT

### 9.0 CONFIDENTIALITY REQUEST

For electronic filing, a preliminary copy of the confidentiality request is saved with filename: request.pdf.

### 10.0 EQUIPMENT LIST

#### 1) Radiated Emissions Test

Equipment	EMI Test Receiver	Spectrum Analyzer	Biconical Antenna
Registration No.	EW-3156	EW-2249	EW-0571
Manufacturer	R&S	ROHDESCHWARZ	EMCO
Model No.	ESR26	FSP30	3104C
Calibration Date	August 01, 2019	May 16, 2019	July 23, 2019
Calibration Due Date	August 01, 2020	May 16, 2020	July 23, 2021

Equipment	Log Periodic Antenna	Double Ridged Guide Antenna	14m Double Shield RF Cable (20MHz - 6GHz)
Registration No.	EW-1042	EW-1133	EW-2074
Manufacturer	EMCO	EMCO	RADIALL
Model No.	3148	3115	Nm-RG142-
Calibration Date	November 23, 2018	November 29, 2018	November 14, 2019
Calibration Due Date	November 23, 2020	May 29, 2020	November 14, 2020

Equipment	15m 40GHz indoor RF Cable	RF Preamp (9kHz to 6000MHz)	Solid State Low Noise Preamp (1 - 18)GHz
Registration No.	EW-3032	EW-3424	EW-3229
Manufacturer	GREATBILLION	SCHWARZBECK	BONN ELEKTRO
Model No.	SMA(m) St-SMA (m) St, 15m long	BBV9744	BLMA 0118-5G
Calibration Date	May 14, 2019	July 23, 2019	June 28, 2019
Calibration Due Date	May 14, 2020	July 23, 2020	June 28, 2020

Equipment	Pyramidal Horn Antenna	Notch Filter (cutoff frequency 2.4GHz to 2.5GHz) 2 pieces	Active Loop H-field (9kHz to 30MHz)
Registration No.	EW-0905	EW-2213	EW-3326
Manufacturer	EMCO	MICROTRONICS	EMCO
Model No.	3160-09	BRM50701-02	6502
Calibration Date	July 23, 2019	July 12, 2019	March 21, 2019
Calibration Due Date	January 23, 2021	May 13, 2020	September 21, 2020



**TEST REPORT**

2) Conducted Emissions Test

<b>Equipment</b>	<b>RF Cable 80cm (RG142) (9kHz to 30MHz)</b>	<b>Artificial Mains Network</b>	<b>EMI Test Receiver</b>
Registration No.	EW-2451	EW-2874	EW-3156
Manufacturer	RADIALL	ROHDESCHWARZ	R&S
Model No.	RF Cable 80cm (RG142) (9kHz to 30MHz)	ENV-216	ESR26
Calibration Date	December 08, 2019	July 05, 2019	August 01, 2019
Calibration Due Date	December 08, 2020	July 05, 2020	August 01, 2020

## TEST REPORT

### 3) Bandwidth/Bandedge Measurement Test

<b>Equipment</b>	<b>40GHz 5m RF Cable</b>	<b>Spectrum Analyzer</b>
Registration No.	EW-2701	EW-2249
Manufacturer	GREATBILLION	R&S
Model No.	sma m-m 5m 40G	FSP30
Calibration Date	May 14, 2019	May 16, 2019
Calibration Due Date	May 14, 2020	May 16, 2020

**END OF TEST REPORT**