

M5AtomS3R

Model:
AtomS3R Ext

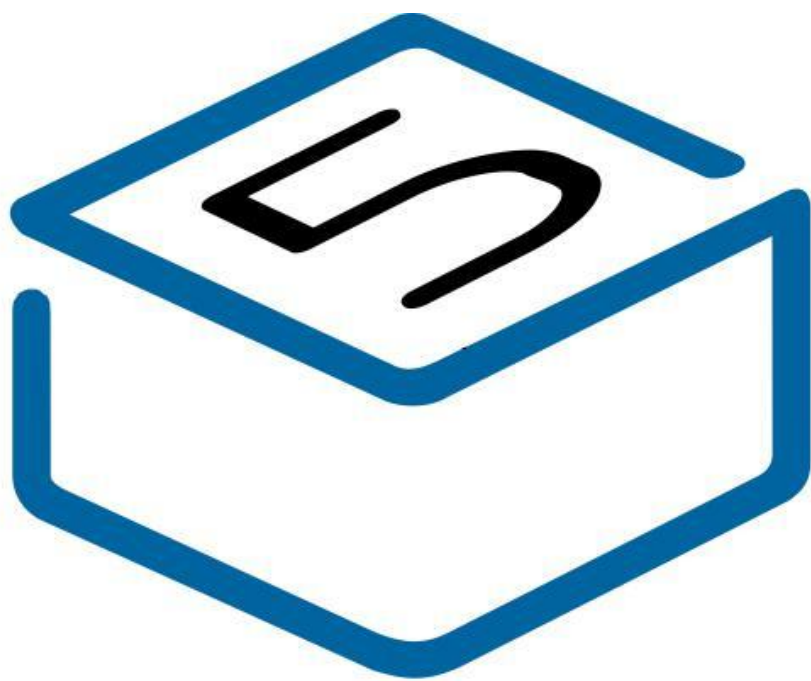

M5STACK

2024

CONTENTS

1. OUTLINE	3
1.1. AtomS3R Ext.	3
2. SPECIFICATIONS	4
2.1. Assembly diagram	5
2.2. Product Size	6
3. QUICK START	7
3.1. SCAN Wi-Fi	8
3.2. SCAN BLE Device	9
4. FCC Warning	10

1. OUTLINE

The **AtomS3R Ext** is a highly integrated programmable controller based on the ESP32-S3 microcontroller. It integrates an **ESP32-S3-PICO-1-N8R8** main controller with WiFi and BLE functionality, 8MB onboard FLASH, and 8MB PSRAM. It includes a reserved FPC interface for adding different camera sensors according to customer needs, an onboard BMM150 magnetometer, and a BMI270 accelerometer and gyroscope. It also features a Type-C interface for power supply and firmware downloads, an HY2.0-4P expansion port, and six GPIO and power pins for expansion. The product measures only 24x24x12mm, making it suitable for various embedded smart device applications.

1.1. AtomS3R Ext

1. **Communication Capabilities:**

- Main Controller: ESP32-S3-PICO-1-N8R8
- Wireless Communication: Wi-Fi (WIFI)\BLE
- Expansion Port: HY2.0-4P interface, can connect and expand I2C sensors

2. **Processor and Performance:**

- Processor Model: Xtensa LX7 (ESP32-S3-PICO-1-N8R8)
- Memory Capacity: 8MB Flash, 8MB PSRAM
- Processor Operating Frequency: Xtensa® dual-core 32-bit LX7 microprocessor, up to 240 MHz

3. **Sensors:**

- Magnetometer: BMM150
- Accelerometer and Gyroscope: BMI270

4. **GPIO Pins and Programmable Interfaces:**

- Expansion Port: HY2.0-4P interface, can connect and expand I2C sensors
- Bottom Reserved: 6 GPIO and power pins for expansion

5. **Others:**

- Interface: Type-C interface for power supply and firmware downloads
- Physical Dimensions: 24×24×12 mm, reserved M2 screw hole for mounting
-

2. SPECIFICATIONS

Specification		Details
MCU		ESP32-S3-PICO-1-N8R8 @ Xtensa dual-core 32-bit LX7, 240MHz
Communication Capabilities		Wi-Fi, BLE I2C sensor expansion, Infrared emitter, OTG/CDC functionality
Flash Storage Capacity		8MB FLASH
PSRAM Storage Capacity		8MB PSRAM
Expansion Port		HY2.0-4P interface, for connecting and expanding I2C sensors
Camera FPC Connector		24P, 0.5mm pitch
Power Supply Voltage		DC 4.5-5.5V (requires external power supply)
Dimensions		24 * 24 * 12 mm
Operating Temperature		-10°C to 40°C
MIC	Wi-Fi Working Frequency	802.11b/g/n20:2412 MHz-2472 MHz
		802.11n40:2422 MHz-2462 MHz
802.11b:2484 MHz		
	BLE Working Frequency	2402MHz-2480MHz
CE	Wi-Fi Working Frequency	802.11b/g/n20:2412 MHz-2472 MHz
		802.11n40:2422 MHz-2462 MHz
	Maximum EIRP	802.11b:17.27dBm
		802.11g:16.82dBm
		802.11n20:16.17dBm
		802.11n40:16.22dBm
	BLE Working Frequency	2402MHz-2480MHz
BLE Maximum EIRP	5.52dBm	
FCC	Wi-Fi Working Frequency	2412 MHz-2472 MHz (802.11b,g,n-HT20)
		2422 MHz-2462 MHz(802.11n-H40)
	Wi-Fi Maximum Conducted Peak Output Power	21.76dBm
	BLE Working Frenquency	2402MHz-2480MHz(BLE 1M/2M)
	BLE Maximum Conducted Peak Output Power	8.71dBm
Rated Current		0.5A
Manufacturer		M5STACK TECHNOLOGY CO., LTD.
Manufacturer address		501, Tangwei Business Building, Tangwei Community, Fuhai Street, Bao'an District, Shenzhen, China

2.1 Assembly diagram

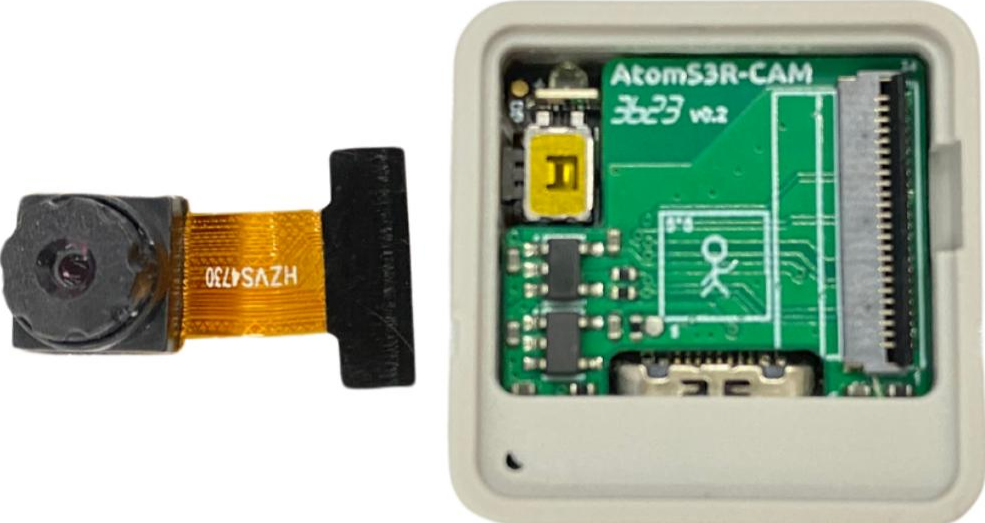

2.2 Product Size

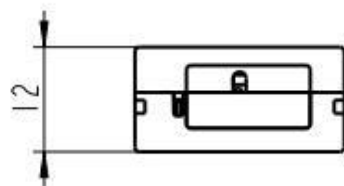
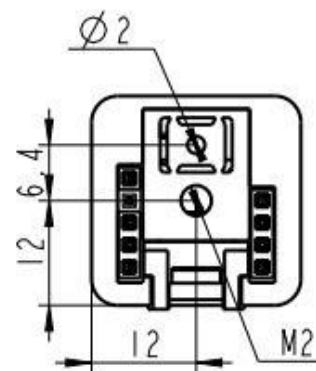
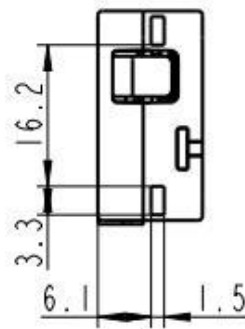
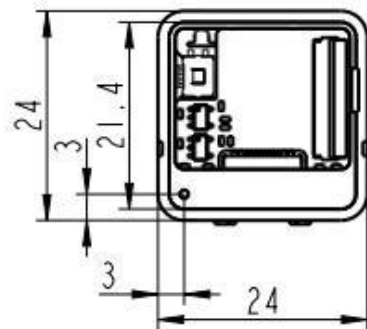
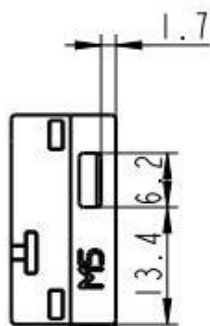
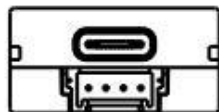

UNIT: mm

3. QUICK START

3.1. Print WiFi information

1. Open Arduino IDE (Refer to https://docs.m5stack.com/en/arduino/arduino_ide for the installation guide for the development board and software)
2. Press and hold the reset button for 2 seconds until the green light turns on
3. Select the ESP32S3 DEV Module board and the corresponding port, then upload the code
4. Open the serial monitor to display the scanned WiFi and signal strength information



```
ESP32S3R_EXT_WIFI | Arduino 1.8.19
File Edit Sketch Tools Help

ESP32S3R_EXT_WIFI
1 #include "WiFi.h"
2
3 void setup() {
4   Serial.begin(115200);
5   WiFi.mode(WIFI_STA);
6   WiFi.disconnect();
7   delay(100);
8
9   Serial.println("Scanning for WiFi networks...");
10  int n = WiFi.scanNetworks();
11  if (n == 0) {
12    Serial.println("No networks found.");
13  } else {
14    Serial.print(n);
15    Serial.println(" networks found.");
16    for (int i = 0; i < n; ++i) {
17      Serial.print(i + 1);
18      Serial.print(": ");
19      Serial.print(WiFi.SSID(i));
20      Serial.print(" (");
21      Serial.print(WiFi.RSSI(i));
22      Serial.print(")");
23      Serial.println((WiFi.encryptionType(i) == WIFI_AUTH_OPEN) ? " " : "*");
24      delay(10);
25    }
26  }
27  Serial.println("");
28 }
29
30 void loop() {
31   // put your main code here, to run repeatedly:
32 }
33
```

COM20

```
17:20:58.755 -> Scanning for WiFi networks...
17:20:58.755 -> 35 networks found.
17:20:58.755 -> 1: M5-UiFlow-Zone (-34)*
17:20:58.801 -> 2: XLOT (-34)*
17:20:58.801 -> 3: M5-R&D (-39)*
17:20:58.801 -> 4: WiFi_ADF4 (-39)*
17:20:58.801 -> 5: DIANJIXZ (-45)*
17:20:58.848 -> 6: Xiaomi_32BD (-47)*
17:20:58.848 -> 7: M5-UiFlow-Zone (-53)*
17:20:58.848 -> 8: M5-UiFlow-Zone (-54)*
17:20:58.848 -> 9: CenturyLink2842 (-55)*
17:20:58.848 -> 10: M5-UiFlow-Zone (-56)*
17:20:58.895 -> 11: esp-shui (-56)*
17:20:58.895 -> 12: CMCC-FSNG (-57)*
17:20:58.895 -> 13: YUESHIQI-602 (-57)*
17:20:58.895 -> 14: ChinaNet-hZsm (-57)*
```

Autoscroll Show timestamp

Newline

3. QUICK START

3.1. Print BLE information

1. Open Arduino IDE (Refer to https://docs.m5stack.com/en/arduino/arduino_ide for the installation guide for the development board and software)
2. Press and hold the reset button for 2 seconds until the green light turns on
3. Select the ESP32S3 DEV Module board and the corresponding port, then upload the code
4. Open the serial monitor to display the scanned BLE and signal strength information

```
ATOMS3R_EXT_BLE | Arduino 1.8.19
File Edit Sketch Tools Help

ATOMS3R_EXT_BLE
1 #include "BLEDevice.h"
2
3 class MyAdvertisedDeviceCallbacks: public BLEAdvertisedDeviceCallbacks {
4     void onResult(BLEAdvertisedDevice advertisedDevice) {
5         Serial.print("Advertised Device: ");
6         Serial.println(advertisedDevice.toString().c_str());
7     }
8 };
9
10 void setup() {
11     Serial.begin(115200);
12     Serial.println("Starting BLE scan...");
13
14     BLEDevice::init("");
15
16     BLEScan* pBLEScan = BLEDevice::getScan();
17     pBLEScan->setAdvertisedDeviceCallbacks(new MyAdvertisedDeviceCallbacks());
18     pBLEScan->setActiveScan(true); // Active scan uses more power, but get results faster
19     pBLEScan->start(10, false); // Scan for 10 seconds
20 }
21
22 void loop() {
23     // Do nothing here
24 }
25
```

```
COM18
16:32:55.340 -> Advertised Device: Name: , Address: 29:b2:79:b9:a3:a0, manufacturer data: 060001092022f2ad5527637974d01222aa793bcbc9fc4c359e2392776a, rssi: -95
16:32:55.340 -> Advertised Device: Name: , Address: 68:ab:bc:a6:82:56, manufacturer data: 8f030a108212005482a6bcab6881, rssi: -72
16:32:55.387 -> Advertised Device: Name: , Address: 4c:11:0b:4a:ac:06, manufacturer data: 4c0010052818e6dfc1, txPower: 8, rssi: -78
16:32:55.387 -> Advertised Device: Name: , Address: c4:23:5c:6d:7f:cc, manufacturer data: 4c0012020003, rssi: -78
16:32:55.387 -> Advertised Device: Name: , Address: 7c:c2:94:11:dd:b3, manufacturer data: 8f030a10bb1900b1ddd1194c27c81, rssi: -90
16:32:55.434 -> Advertised Device: Name: , Address: 69:9a:a5:ca:0e:76, manufacturer data: 4c001007381fa49766f208, txPower: 12, rssi: -87
16:32:55.481 -> Advertised Device: Name: , Address: 68:8a:2d:9d:69:9a, manufacturer data: 4c000719010e202b778f01000a5a7b38b9d862679f9aa0147c93dfb9a3, rssi: -92
16:32:55.481 -> Advertised Device: Name: , Address: 46:21:43:b4:e4:8f, manufacturer data: 4c0009081302c0a802531b581608006aad6eb4cfc9d7, rssi: -86
16:32:55.481 -> Advertised Device: Name: , Address: 68:13:24:e2:c9:a6, rssi: -94, serviceData: []
16:32:55.528 -> rer data: 4c0012020000, rssi: -75
16:32:55.528 -> Advertised Device: Name: , Address: 4d:7a:15:80:e0:e4, manufacturer data: 4c0016080083cf28ec2b91b1, rssi: -75
16:32:55.575 -> Advertised Device: Name: , Address: 0d:4f:0e:0f:b8:6b, manufacturer data: 06000109202270c24b9ec6b7806f55379bea22271ecd7e87c71f99cb35, rssi: -92
16:32:55.575 -> Advertised Device: Name: , Address: 43:85:45:a1:4f:84, manufacturer data: 4c000908130cc0a81f071b5813080a88ba7d27f9c700, rssi: -81
16:32:55.622 -> Advertised Device: Name: , Address: a4:c1:38:8d:a7:00, rssi: -74, serviceData: 0X[[]]
16:32:55.622 -> Advertised Device: Name: , Address: fa:e7:06:2b:fd:91, manufacturer data: 4c0012023503, rssi: -78
16:32:55.714 -> Advertised Device: Name: , Address: c3:3e:25:29:00:03, manufacturer data: 4c0012020003, rssi: -74
16:32:55.714 -> Advertised Device: Name: , Address: 52:88:46:95:91:08, manufacturer data: 4c00160800d660375f0003bf, rssi: -73
16:32:55.806 -> Advertised Device: Name: , Address: 6a:c3:bb:88:c2:0b, manufacturer data: 4c0010050e18874880, txPower: 12, rssi: -89
16:32:55.991 -> Advertised Device: Name: , Address: 4b:c9:66:74:75:f0, manufacturer data: 4c00100607194fa9cd38, txPower: 12, rssi: -87
16:32:55.991 -> Advertised Device: Name: , Address: 24:e8:e2:9b:75:46, manufacturer data: 4c0013080a4d1f30f2970b00, rssi: -91
16:32:56.038 -> Advertised Device: Name: , Address: 64:3d:63:13:1f:b0, manufacturer data: 4c00100607194fa9cd38, txPower: 12, rssi: -82
16:32:56.129 -> Advertised Device: Name: , Address: c1:55:39:b6:23:30, manufacturer data: 4c0012020000, rssi: -69
16:32:56.184 -> Advertised Device: Name: , Address: 41:a0:2a:ea:27:15, manufacturer data: 4c00160800579e01df5e3cae, rssi: -94
16:32:56.184 -> Advertised Device: Name: , Address: dd:3a:2f:71:cc:4f, manufacturer data: 4c0012020003, rssi: -90
16:32:56.265 -> Advertised Device: Name: , Address: f1:79:78:04:24:72, manufacturer data: 4c0012020003, rssi: -84
16:32:56.265 -> Advertised Device: Name: , Address: 73:d0:c7:76:2d:cd, manufacturer data: 4c0010073f1be2cc95d138, txPower: 7, rssi: -77
16:32:56.405 -> Advertised Device: Name: , Address: 75:d9:97:51:7d:8e, manufacturer data: 4c001007211fb4e4ccdc78, txPower: 12, rssi: -84
16:32:56.452 -> Advertised Device: Name: , Address: e4:84:07:a4:3e:e9, rssi: -91
16:32:56.452 -> Advertised Device: Name: , Address: 2e:da:35:f1:e5:1c, manufacturer data: 0600010f2022042879d9cedeb21fc16d6033b9bb7deb6b4e88513f2830, rssi: -95
16:32:56.452 -> Advertised Device: Name: , Address: cd:4e:ff:37:55:dd, manufacturer data: 4c0012020002, rssi: -91
16:32:56.500 -> Advertised Device: Name: , Address: 71:ab:11:45:16:08, manufacturer data: 4c0010053b18f2b4c3, txPower: 12, rssi: -87
16:32:56.545 -> Advertised Device: Name: , Address: 4e:bb:9b:58:79:b4, manufacturer data: 4c00160800c1b1dbbac7dd93, rssi: -66
16:32:56.590 -> Advertised Device: Name: , Address: dc:5d:0a:32:f6:cd, manufacturer data: 4c0012020000, rssi: -88
16:32:57.096 -> Advertised Device: Name: , Address: 65:c0:b9:6e:b8:49, manufacturer data: 4c0010052298728c65, txPower: 8, rssi: -89
16:32:57.329 -> Advertised Device: Name: , Address: 63:70:68:f2:c1:6f, manufacturer data: 4c00160800bb73dcc3dc3fa9, rssi: -86
16:32:57.329 -> Advertised Device: Name: , Address: d5:24:79:0c:93:f0, manufacturer data: 4c0012020001, rssi: -87
16:32:57.699 -> Advertised Device: Name: , Address: 42:bc:23:c2:3a:25, manufacturer data: 4c000c0e007f2849c2940c9d352a1085d4dc1006431d064dde18, rssi: -94
16:32:58.026 -> Advertised Device: Name: , Address: c4:8f:62:41:70:9d, manufacturer data: 4c0012020000, rssi: -94
16:32:58.026 -> Advertised Device: Name: , Address: d6:1e:a5:0c:5b:4e, manufacturer data: 4c001219395de24f1f2dd0ff3eb13c218d86153fee2b613140f7a80194, rssi: -73
16:32:58.213 -> Advertised Device: Name: , Address: fb:01:b0:e5:b4:ed, manufacturer data: 4c0012020002, rssi: -68
16:32:58.351 -> Advertised Device: Name: , Address: cd:55:86:51:87:a7, manufacturer data: 4c0012020003, rssi: -78
16:32:58.537 -> Advertised Device: Name: , Address: d2:e8:b8:38:e8:06, manufacturer data: 4c0012025401, rssi: -98
16:32:58.583 -> Advertised Device: Name: , Address: d0:17:51:8f:06:7e, manufacturer data: 4c0012026e00071106d0de3ee5e0414d36927a38cec0059ba4, rssi: -88
```

4. FCC Warning

FCC Caution:

Any Changes or modifications not expressly approved by the party responsible for compliance could void the user's authority to operate the equipment.

This device complies with part 15 of the FCC Rules. Operation is subject to the following two conditions: (1) This device may not cause harmful interference, and (2) this device must accept any interference received, including interference that may cause undesired operation.

IMPORTANT NOTE:

Note: This equipment has been tested and found to comply with the limits for a Class B digital device, pursuant to part 15 of the FCC Rules. These limits are designed to provide reasonable protection against harmful interference in a residential installation.

This equipment generates, uses and can radiate radio frequency energy and, if not installed and used in accordance with the instructions, may cause harmful interference to radio communications. However, there is no guarantee that interference will not occur in a particular installation. If this equipment does cause harmful interference to radio or television reception, which can be determined by turning the equipment off and on, the user is encouraged to try to correct the interference by one or more of the following measures:

— Reorient or relocate the receiving antenna. — Increase the separation between the equipment and receiver. — Connect the equipment into an outlet on a circuit different from that to which the receiver is connected. — Consult the dealer or an experienced radio/TV technician for help.

FCC Radiation Exposure Statement:

This equipment complies with FCC radiation exposure limits set forth for an uncontrolled environment. The SAR was tested for the device in the body worn mode, and it can meet the SAR limit of FCC.