

### Document Information

Document Number	
Project / Subproject	EP069 – EWE
Created	Sc/Fa
Checked (Short sign / Date / Signature)	
Issued (Short sign / Date / Signature)	

### History

Date	Location	Reason	Editor
03.01.2018	Page 4: Change NRF52832 Page 9/10: Picture added	Complement	Sc
05.02.2018	Page 1: English Page 10-15: Add Pictures RF Part, Add FCC Statements, Label Location, Assembly Process	Complement	Sc

### Project Documents

Referenz	Datum	Dokument	Autor

### 1 General description

Boring is the machining process of enlarging a hole that has already been drilled (or cast) in a metal piece, by means of a boring head containing a single-point cutting tool. BIG Kaiser is a world leader in the design and production of high precision, fine adjustable boring heads. Our digital boring tools are capable of showing adjusting values in an integrated LCD display with an accuracy of  $1\mu\text{m}$ , and send them via Bluetooth to an external receiver.



Picture 1. EWE Digital boring heads.

### 1.1 Modul Description

Our Electronic Module with p/n **E-395.163** provides the following components and functionalities:

- Showing adjusting position in an LCD Display
- Sending adjusting position and other information via Bluetooth thanks to an internal, non-detachable Antenna
- Reading and processing signals from a positioning sensor
- Pushbutton for tool Start and Reset
- Provide power to the complete Module thanks to an internal CR1025 Battery

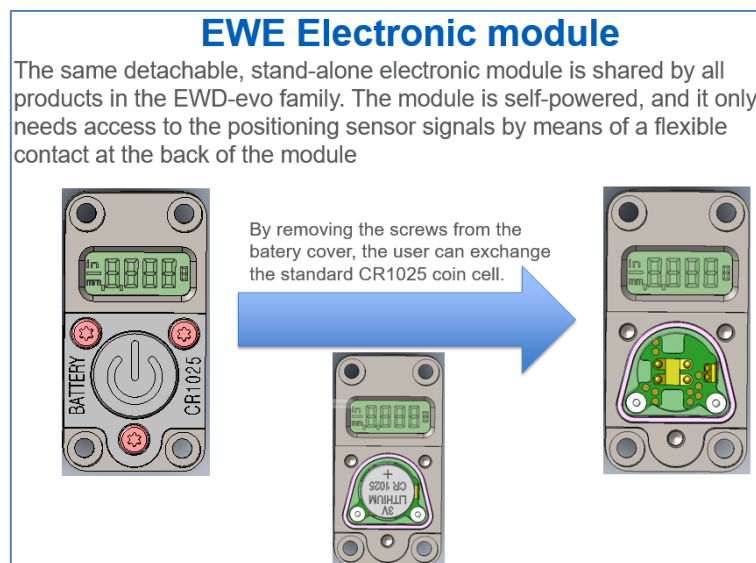

Picture 2. EWE Electronic Module.

Our **Electronic Module E-395.163 is not for sale to external companies** (it is only used in BIG Kaiser Products). It is attached to the tool body by means of four secured screws. Only the following finished products from BIG Kaiser for the US Market contain this module:

- p/n: 310.866 / **Description:** EWE100-203E-CKB6
- p/n: 310.875 / **Description:** EWE100-203E-CKB7
- p/n: 310.845 / **Description:** EWE41-74E-CKB4
- p/n: 310.855 / **Description:** EWE53-95E-CKB5
- p/n: 310.861 / **Description:** EWE68-150E-CKB6
- p/n: 112.120 / **Description:** EWE2-152E-CK6
- p/n: 112.320 / **Description:** EWE2-32E-CK5
- p/n: 318.114 / **Description:** EWE200E-AL

### 2 Block Diagram

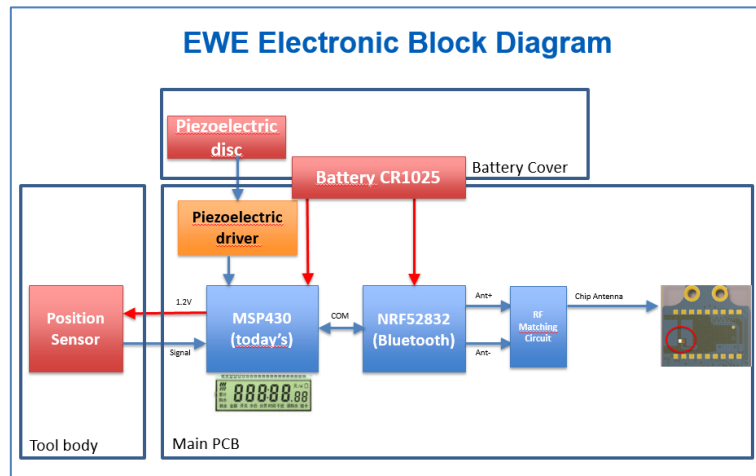

Picture 3. Electronic Block Diagram.

The electronics module consists of the following electronic elements:

- Battery CR1025**, 30mA.h
- MSP430 block.** Based on the MSP430GF479 from Texas Instruments. It reads the position sensor, the pushbutton and the battery level; it shows the position in the display; and it communicates with the Bluetooth chip via UART.
- LCD Display.** Customized 7-Segment LCD from Adkom GmbH
- Piezoelectric sensor** located beneath the battery cover. It provides an electric charge which is proportional to the pressure applied by the user on the pushbutton
- Piezo driver.** Signal pre-processing to provide MSP430 with a step signal when the user presses the On/Reset Button.
- NRF52832 block.** It provides the Bluetooth functionality. It works as a wireless interface between the MSP430 and the outside world, converting serial port communication into Bluetooth and vice-versa.
- RF Matching Network.** Provides the Impedance matching to minimize return losses in the antenna
- Antenna.** Ceramic chip antenna, p/n 2450AT07A0100T from Johanson Technology Inc., soldered on the main board. Note: Due to the metal environment, the antenna gain is 1.0 dBi.

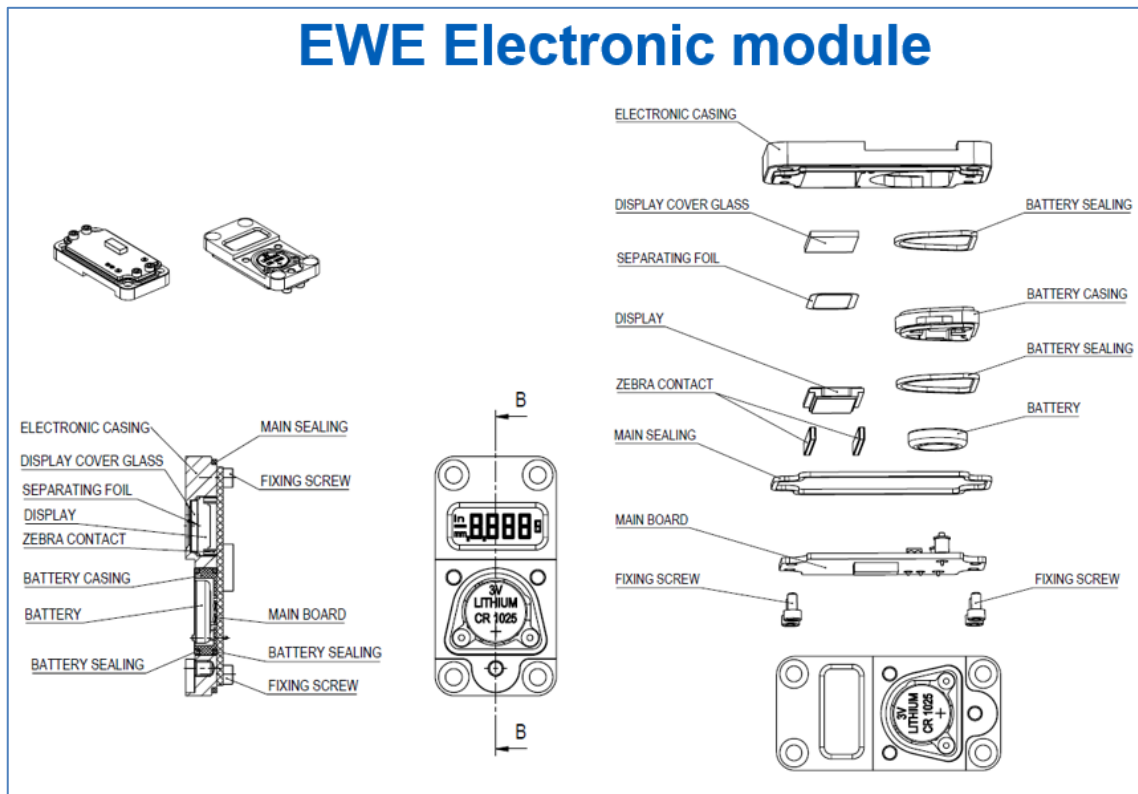

**Picture 4.** Mechanical construction of the module

### 3 Functionality

The list below shows the main functionality of the software.

- Operation Modes
  - Normal operation mode
  - Calibration station mode
  - RF constant carrier mode
  - RF Bluetooth direct test mode
  - Disable Bluetooth completely (No Bluetooth option)
- Synchronization / Communication between MSP and NRF
- Calculate position and show on display
- Tool configuration possible during calibration (programming) or via Bluetooth (runtime)
- Store data (position history) in flash memory
  - With time-stamp: Real time clock
- Power management
- Bluetooth functions
  - Sending of position
  - Set configuration of the tool
  - Get information of the tool ( Status, SerialNr, SW/HW Version)
  - Set position history parameters ( Time, BatchNr, TargetDia)
  - Access to position history (read, erase)

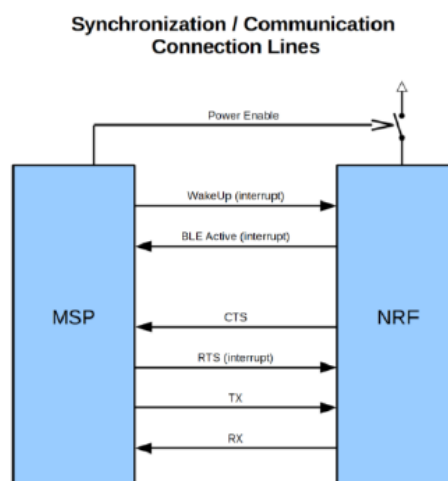

**Picture 5.** Communication lines between MSP430 and nRF52

The software can work in different operation modes. This can be entered via hardware (Mode-Pins) or via software (Bluetooth interface and/or calibration station).

Modes changed by hardware pins:

- Normal operation mode
- Calibration station mode
- RF Radio test mode
- RF Bluetooth direct test mode

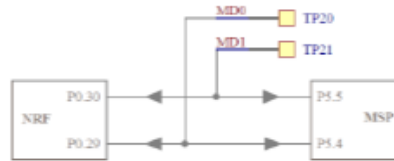

Modes changed by software (Bluetooth interface and/or calibration station).

- Disable Bluetooth completely (No Bluetooth option)

### Switch between operation modes

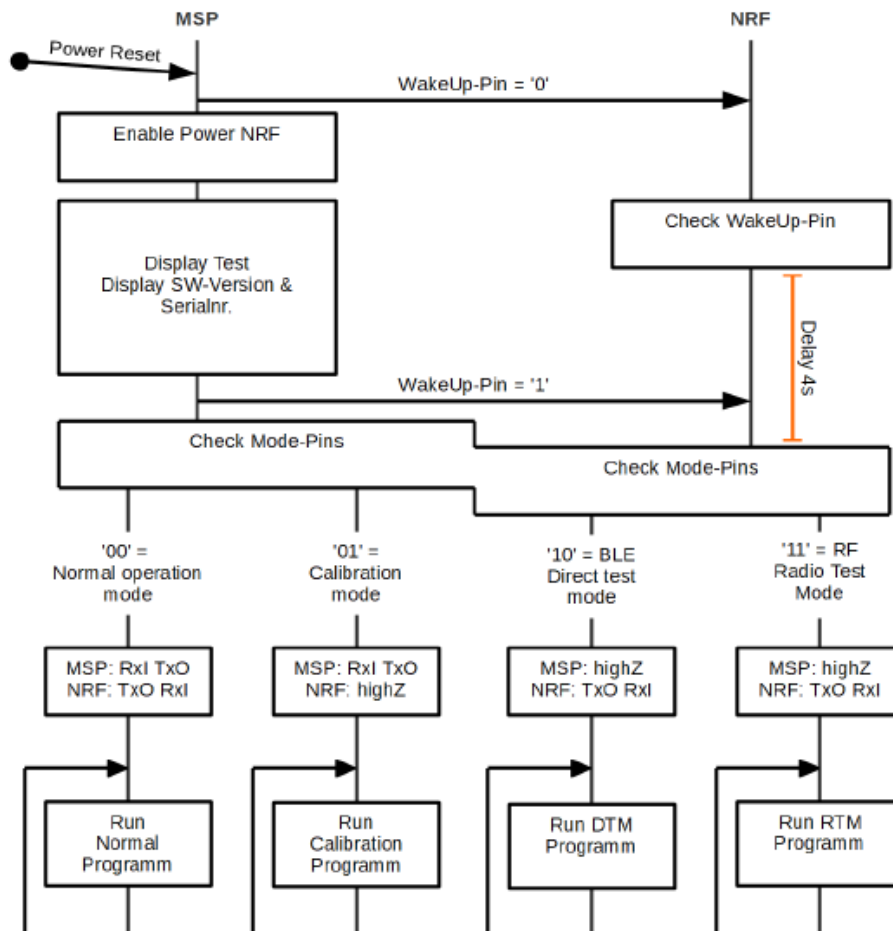

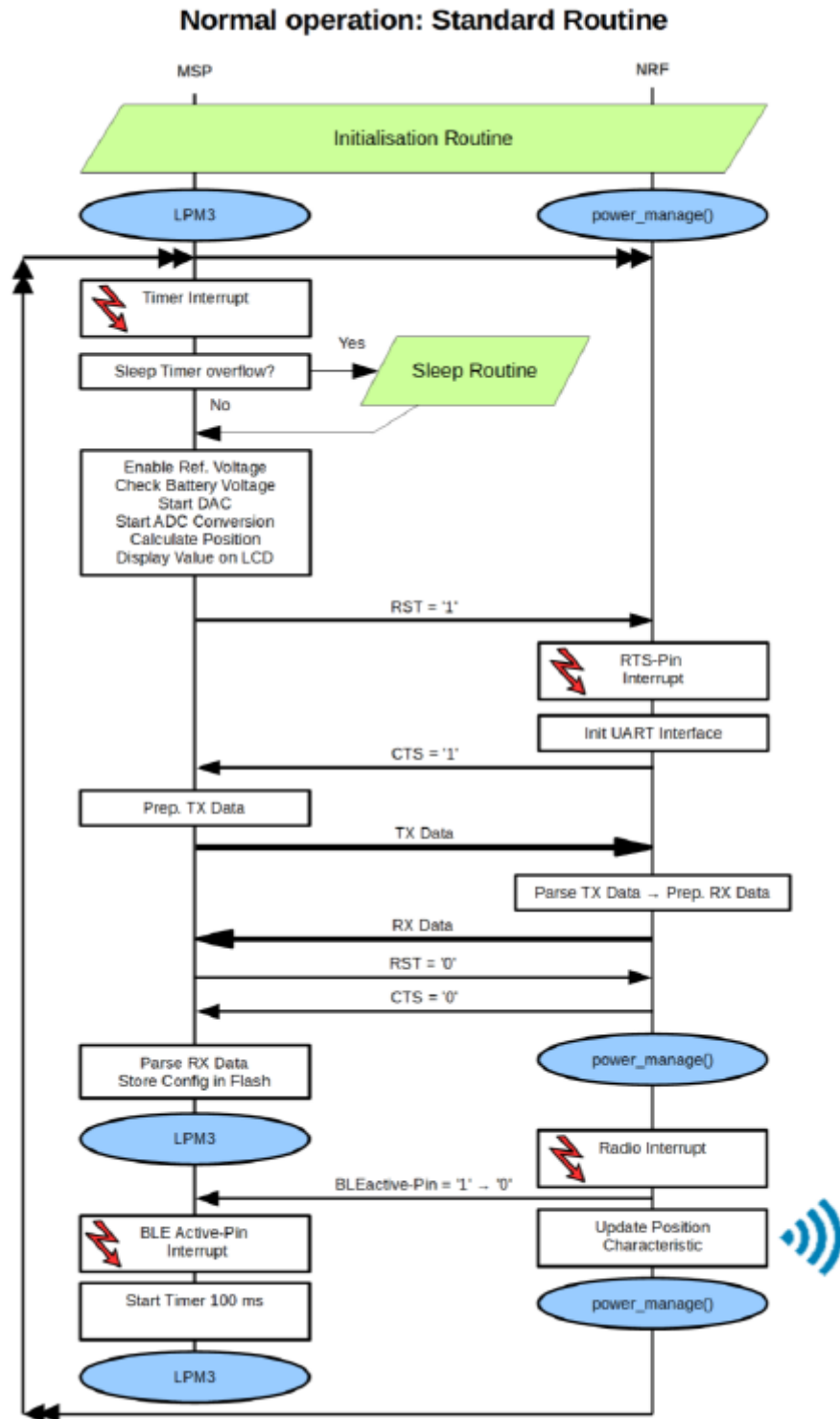

Picture 6. Software Flowchart



### 4 Specification

#### Battery lifetime:

- ON: Minimum 4000 cycles (One cycle is equivalent to 40s operation)
- OFF: 1 year
- Battery type: CR1025 (3.3v Nominal Voltage, 30 mA.h Capacity)

#### Operating Voltage:

- Maximum Allowed Voltage: 3.6V
- Standard Operating Voltage: 2.5V – 3.3V
- Limit for Low Battery Indication: 2.5V
- Limit for Shutdown: 2.3V

#### Wireless communication:

- Technology: Bluetooth Low Energy
- Range: Minimum 2m, optimum 10m (in any direction, tool inside a CNC working area)
- Communication rate
  - o Advertising: every 200ms
  - o Position indication: every 200ms
  - o History download: one item each 200ms
- Antenna type: Chip Ceramic Antenna.

#### LCD:

- Viewing Area: 5.8x15.8 mm
- Standard: 40 segments, 1/3 Bias, 1/3 Duty Cycle (18 pins in total, 3 Common lines)

#### Button functionalities:

- Short press: Tool ON
- Press 1s: Display reset

#### Standard OFF Timers (configurable by Bluetooth):

- The tool goes OFF to lowest power mode 30s after the last user action (button or adjustment)
- The tool goes OFF to lowest power mode 2min after the last user action if there is an active communication

#### Mechanical Specification

- Sealing: IP69K
- Centrifugal forces: 10700g at electronics board (112 series)

### 5 Pictures Module



Module Top View



Module Bottom View



Module Side View

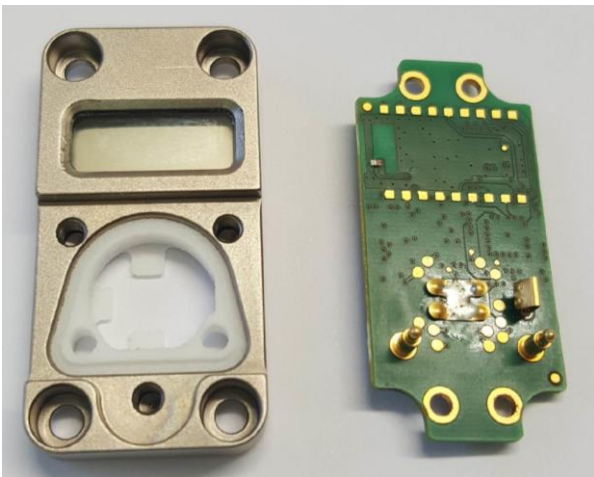

Mechanical Lid and PCB Top

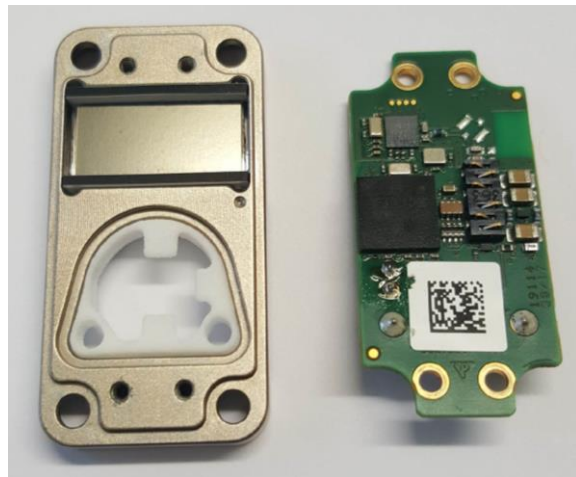

Mechanical Lid and PCB Bottom

### 6 Pictures RF Part on Module

Matching Network and Antenna



Antenna Top View

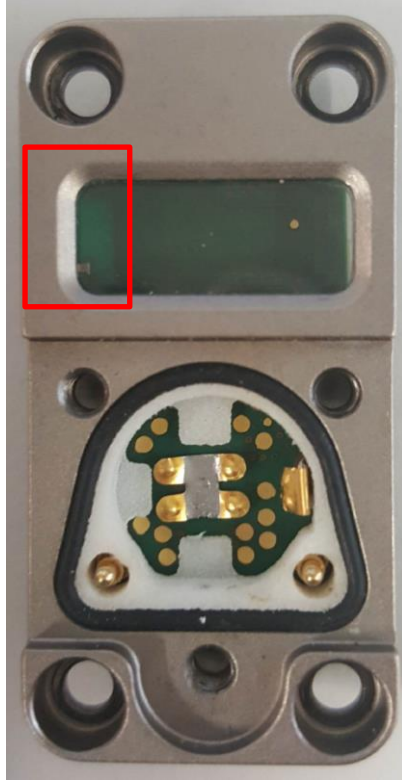

Antenna Top View

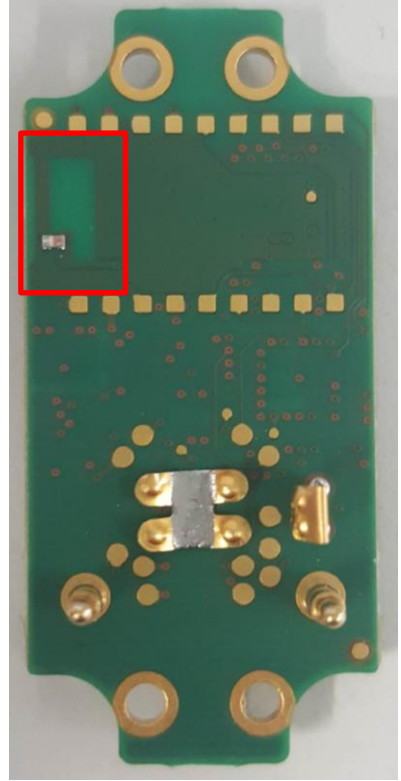

### 7 Pictures End Product



Module in Tool (EWE 68-150) with Battery Cover



Module in Tool (EWE68-150) without Battery Cover

### 8 FCC Statements

BIG KAISER will ship every tool with this FCC statements on a separate leaflet. The end product is a Class A device: Business to Business only.

*This device complies with Part 15 of the FCC Rules. Operation is subject to the following two conditions: (1) this device may not cause interference, and (2) this device must accept any interference, including interference that may cause undesired operation of the device.*

**Caution: Radio Frequency Radiation Exposure**

*This equipment complies with FCC radiation exposure limits set forth for an uncontrolled environment and meets the FCC radio frequency (RF) Exposure Guidelines. This equipment should be installed and operated keeping the radiator at least 0.43 cm or more away from person's body in normal use position.*

**WARNING:** (Part 15.21): Changes or modifications not expressly approved by the party responsible for compliance could void the user's authority to operate this equipment.

*This device complies with part 15 of the FCC Rules and Industry Canada license-exempt RSS standard(s). Operation is subject to the following two conditions:*

- (1) This device may not cause harmful interference, and*
- (2) this device must accept any interference received, including interference that may cause undesired operation.*

*This equipment has been tested and found to comply with the limits for a Class B digital device, pursuant to part 15 of the FCC Rules. These limits are designed to provide reasonable protection against harmful interference in a residential installation. This equipment generates, uses and can radiate radio frequency energy and, if not installed and used in accordance with the instructions, may cause harmful interference to radio communications. However, there is no guarantee that interference will not occur in a particular installation. If this equipment does cause harmful interference to radio or television reception, which can be determined by turning the equipment off and on, the user is encouraged to try to correct the interference by one or more of the following measures:*

- *Reorient or relocate the receiving antenna.*
- *Increase the separation between the equipment and receiver.*
- *Connect the equipment into an outlet on a circuit different from that to which the receiver is connected.*
- *Consult the dealer or an experienced radio/TV technician for help.*

**Notes (ISED):**

*(EN) This Class B digital apparatus complies with Canadian ICES-003 and RSS-210. Operation is subject to the following two conditions: (1) this device may not cause interference, and (2) this device must accept any interference, including interference that may cause undesired operation of the device.*

*(FR) Cet appareil numérique de classe B est conforme aux normes canadiennes ICES-003 et RSS-210. Son fonctionnement est soumis aux deux conditions suivantes: (1) cet appareil ne doit pas causer d'interférence et (2) cet appareil doit accepter toute interférence, notamment les interférences qui peuvent affecter son fonctionnement.*

**(EN) Radio frequency (RF) Exposure Information**

*The radiated output power of the Wireless Device is below the Innovation, Science and Economic Development (ISED) radio frequency exposure limits. The Wireless Device should be used in such a manner such that the potential for human contact during normal operation is minimized.*

*This device has also been evaluated and shown compliant with the ISED RF Exposure limits under mobile exposure conditions (antennas at least 0.58cm from a person's body).*

**(FR) Informations concernant l'exposition aux fréquences radio (RF)**

*La puissance de sortie émise par l'appareil de sans fil est inférieure à la limite d'exposition aux fréquences radio d'Innovation, Sciences et Développement économique Canada (ISDE). Utilisez l'appareil de sans fil de façon à minimiser les contacts humains lors du fonctionnement normal.*

*Ce périphérique a également été évalué et démontré conforme aux limites d'exposition aux RF d'ISDE dans des conditions d'exposition à des appareils mobiles (les antennes se situent à moins de 20cm du corps d'une personne).*

#### 8.1 OEM Statement for Host Integration

The module is assembled only in the assembly department of the company BIG KAISER. It is not permitted to buy the module only. Customers can only buy the final end product. The process of assembly is documented in chapter 9: Assembly Process.

### 8.4 Label Requirements

The required labels will be placed on the module and the end products as shown in the pictures below.

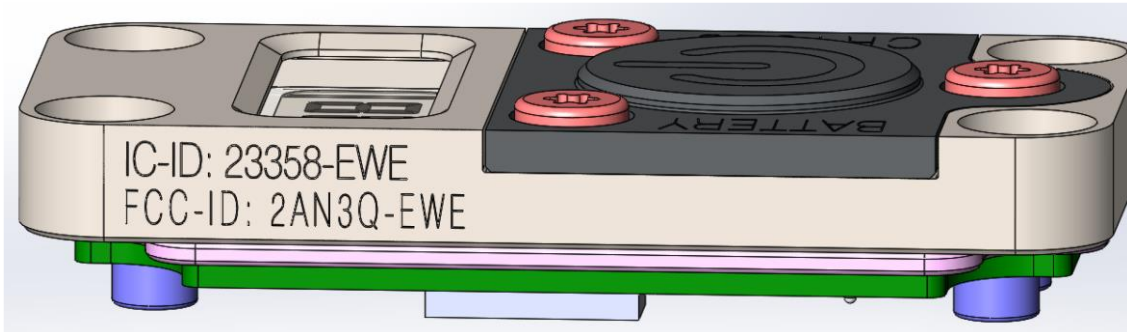

Label on Module (side view)

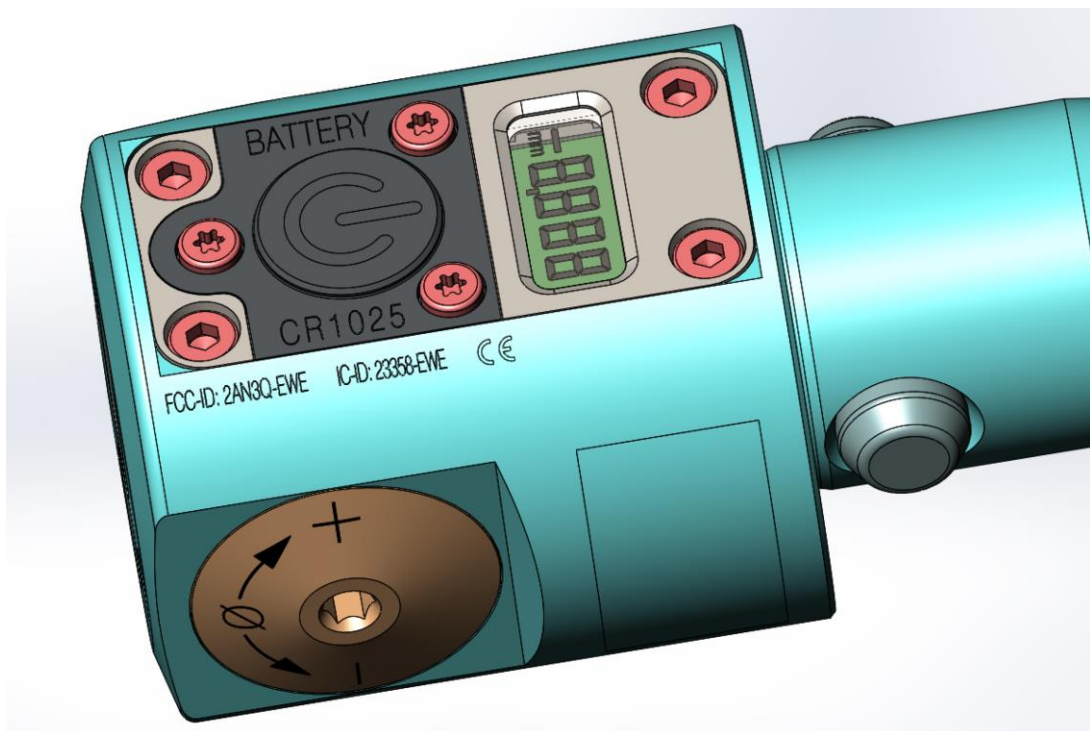

Label on End Product

### 9 Assembly Process

1. Pre assemble the electronic lid (Display, Display contacts, sealing and battery holder)
2. Mount PCB on electronic lid with 4 silver screws
3. Place sealing and rubber mat on PCB
4. Get preassembled tool body (check sensor contacts are clean)
5. Place module in preassembled tool body
6. Mount module on tool body with 4 black screws
7. Place Battery cover on module. Cover 4 black screw heads with gray glue. Customer is not able to open it anymore.

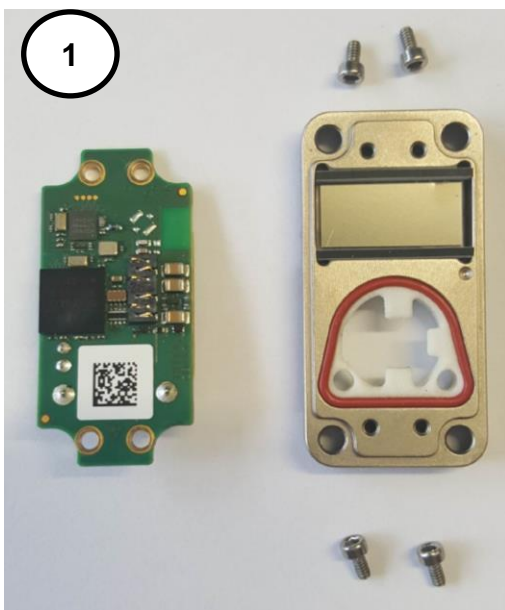

6



7

