

MEASUREMENT REPORT

FCC PART 15C / RSS-247 WLAN 802.11b/g/n

FCC ID: 2AN2O-TSW02
IC: 23317-TSW02
Applicant: Beijing Roborock Technology Co., Ltd.
Application Type: Certification
Product: Robotic Vacuum Cleaner
Model No.: roborock S7
FCC Classification: Digital Transmission System (DTS)
FCC Rule Part(s): Part 15 Subpart C (Section 15.247)
IC Rule(s): RSS 247 Issue 2, RSS-GEN Issue 5
Test Procedure(s): ANSI C63.10-2013
Test Date: September 26 ~ November 24, 2020

Reviewed By: Sherry Jiang
(Sherry Jiang)

Approved By: Robin Wu
(Robin Wu)



The test results relate only to the samples tested.

This equipment has been shown to be capable of compliance with the applicable technical standards as indicated in the measurement report and was tested in accordance with the measurement procedures specified in ANSI C63.10-2013. Test results reported herein relate only to the item(s) tested.

The test report shall not be reproduced except in full without the written approval of MRT Technology (Suzhou) Co., Ltd.

Revision History

Report No.	Version	Description	Issue Date	Note
2009RSU063-U1	Rev. 01	Initial Report	12-17-2020	Valid

CONTENTS

Description	Page
1. General Information	5
1.1. Applicant	5
1.2. Manufacturer	5
1.3. Testing Facility.....	5
2. PRODUCT INFORMATION	6
2.1. Equipment Description	6
2.2. Product Specification Subjective to this Report	6
2.3. Working Frequencies for this report.....	7
2.4. Test Mode	7
2.5. Description of Test Software.....	7
2.6. Duty Cycle.....	8
2.7. EMI Suppression Device(s)/Modifications.....	9
2.8. Test Environment Condition.....	9
2.9. Description of Test Configuration	9
2.10. Test System Details	9
3. ANTENNA REQUIREMENTS.....	10
4. TEST EQUIPMENT CALIBRATION DATE.....	11
5. MEASUREMENT UNCERTAINTY	15
6. TEST RESULT	16
6.1. Summary.....	16
6.2. Occupied Bandwidth Measurement.....	17
6.2.1. Test Limit	17
6.2.2. Test Procedure used.....	17
6.2.3. Test Setting.....	17
6.2.4. Test Setup	18
6.2.5. Test Result.....	19
6.3. Output Power Measurement.....	29
6.3.1. Test Limit	29
6.3.2. Test Procedure Used	29
6.3.3. Test Setting.....	29
6.3.4. Test Setup	30
6.3.5. Test Result.....	31
6.4. Power Spectral Density Measurement.....	33
6.4.1. Test Limit	33

6.4.2.	Test Procedure Used	33
6.4.3.	Test Setting.....	33
6.4.4.	Test Setup	33
6.4.5.	Test Result.....	34
6.5.	Conducted Band Edge and Out-of-Band Emissions	39
6.5.1.	Test Limit	39
6.5.2.	Test Procedure Used	39
6.5.3.	Test Setting.....	39
6.5.4.	Test Setup	40
6.5.5.	Test Result.....	41
6.6.	Radiated Spurious Emission Measurement	50
6.6.1.	Test Limit	50
6.6.2.	Test Procedure Used	51
6.6.3.	Test Setting.....	51
6.6.4.	Test Setup	53
6.6.5.	Test Result.....	54
6.7.	Radiated Restricted Band Edge Measurement.....	68
6.7.1.	Test Limit	68
6.7.2.	Test Procedure Used	71
6.7.3.	Test Setting.....	71
6.7.4.	Test Setup	72
6.7.5.	Test Result.....	73
6.8.	AC Conducted Emissions Measurement	105
6.8.1.	Test Limit	105
6.8.2.	Test Setup	105
6.8.3.	Test Result.....	106
7.	CONCLUSION	108
	Appendix A - Test Setup Photograph	109
	Appendix B - EUT Photograph.....	110

1. General Information

1.1. Applicant

Beijing Roborock Technology Co., Ltd

Floor 6, Suite 6016, 6017, 6018, Building C, Kangjian Baosheng Plaza, No.8
Heiquan Road, Haidian District, Beijing, P.R. China

1.2. Manufacturer

Beijing Roborock Technology Co., Ltd

Floor 6, Suite 6016, 6017, 6018, Building C, Kangjian Baosheng Plaza, No.8
Heiquan Road, Haidian District, Beijing, P.R. China

1.3. Testing Facility

<input checked="" type="checkbox"/>	<p>Test Site – MRT Suzhou Laboratory</p> <p>Laboratory Location (Suzhou - Wuzhong) D8 Building, No.2 Tian'edang Rd., Wuzhong Economic Development Zone, Suzhou, China</p> <p>Laboratory Location (Suzhou - SIP) 4b Building, Liando U Valley, No.200 Xingpu Rd., Shengpu Town, Suzhou Industrial Park, China</p> <p>Laboratory Accreditations</p> <p>A2LA: 3628.01 CNAS: L10551 FCC: CN1166 ISED: CN0001 VCCI: R-20025, G-20034, C-20020, T-20020</p>
<input type="checkbox"/>	<p>Test Site – MRT Shenzhen Laboratory</p> <p>Laboratory Location (Shenzhen) 1G, Building A, Junxiangda Building, Zhongshanyuan Road West, Nanshan District, Shenzhen, China</p> <p>Laboratory Accreditations</p> <p>A2LA: 3628.02 CNAS: L10551 FCC: CN1284 ISED: CN0105</p>
<input type="checkbox"/>	<p>Test Site – MRT Taiwan Laboratory</p> <p>Laboratory Location (Taiwan) No. 38, Fuxing 2nd Rd., Guishan Dist., Taoyuan City 333, Taiwan (R.O.C.)</p> <p>Laboratory Accreditations</p> <p>TAF: L3261-190725 FCC: 291082, TW3261 ISED: TW3261</p>

2. PRODUCT INFORMATION

2.1. Equipment Description

Product Name	Robotic Vacuum Cleaner
Model No.	roborock S7
HVIN	BL-M8189FS6
FVIN	N/A
Series number	TSSB2S03400143
Wi-Fi Specification	802.11b/g/n
Antenna Delivery	1*TX + 1*RX
Accessories	
Rechargeable Li-ion Battery	Model No.: BRR-2P4S-5200S; BRR-2P4S-5200D Capacitance: 5200mAh Rated Voltage: 14.4V, 74.88Wh

Note : EUT can be shipped with two types of batteries of the same specification. We choose BRR-2P4S-5200S for testing.

2.2. Product Specification Subjective to this Report

Frequency Range	802.11b/g/n-HT20: 2412 ~ 2462 MHz 802.11n-HT40: 2422 ~ 2452 MHz
Channel Number	802.11b/g/n-HT20: 11 802.11b/g/n-HT40: 7
Type of Modulation	802.11b: DSSS 802.11g/n: OFDM
Data Rate	802.11b: 1/2/5.5/11Mbps 802.11g: 6/9/12/18/24/36/48/54Mbps 802.11n: up to 150Mbps
Maximum Output Power	802.11b: 20.44 dBm 802.11g: 26.83 dBm 802.11n-HT20: 26.74 dBm 802.11n-HT40: 26.73 dBm
Antenna Type	FPC Antenna
Antenna Gain	3.84dBi

Note: For other features of this EUT, test report will be issued separately.

2.3. Working Frequencies for this report

802.11b/g/n-HT20

Channel	Frequency	Channel	Frequency	Channel	Frequency
01	2412 MHz	02	2417 MHz	03	2422 MHz
04	2427 MHz	05	2432 MHz	06	2437 MHz
07	2442 MHz	08	2447 MHz	09	2452 MHz
10	2457 MHz	11	2462 MHz	--	--

802.11n-HT40

Channel	Frequency	Channel	Frequency	Channel	Frequency
03	2422 MHz	04	2427 MHz	05	2432 MHz
06	2437 MHz	07	2442 MHz	08	2447 MHz
09	2452 MHz	--	--	--	--

2.4. Test Mode

Test Mode	Mode 1: Transmit by 802.11b (1Mbps)
	Mode 2: Transmit by 802.11g (6Mbps)
	Mode 3: Transmit by 802.11n-HT20 (MCS0)
	Mode 4: Transmit by 802.11n-HT40 (MCS0)

2.5. Description of Test Software

The test utility software used during testing was “adb”.

2.6. Duty Cycle

2.4GHz WLAN (DTS) operation is possible in 20MHz channel bandwidths. The maximum achievable duty cycles for all modes were determined based on measurements performed on a spectrum analyzer in zero-span mode with RBW = 8MHz, VBW = 50MHz. The RBW and VBW were both greater than 50/T, where T is the minimum transmission duration, and the number of sweep points across T were greater than 100. The duty cycles are as follows:

Test Mode	Duty Cycle
802.11b	100%
802.11g	100%
802.11n-HT20	100%
802.11n-HT40	100%

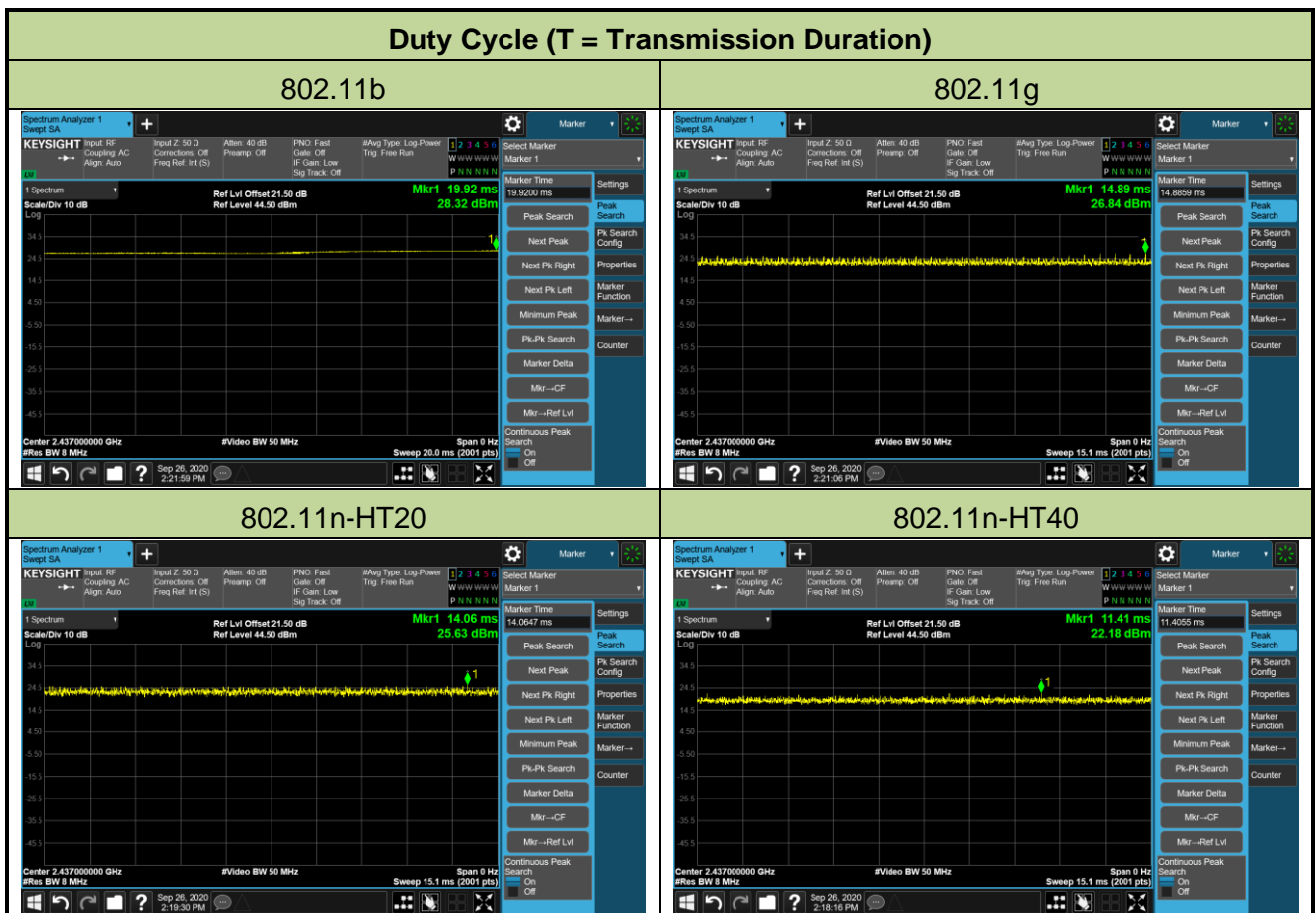

2.7. EMI Suppression Device(s)/Modifications

No EMI suppression device(s) were added and/or no modifications were made during testing.

2.8. Test Environment Condition

Ambient Temperature	15°C ~ 35°C
Relative Humidity	20%RH ~75%RH

2.9. Description of Test Configuration

The device was tested per the guidance ANSI C63.10: 2013 was used to reference the appropriate EUT setup for radiated emissions testing and AC line conducted testing.

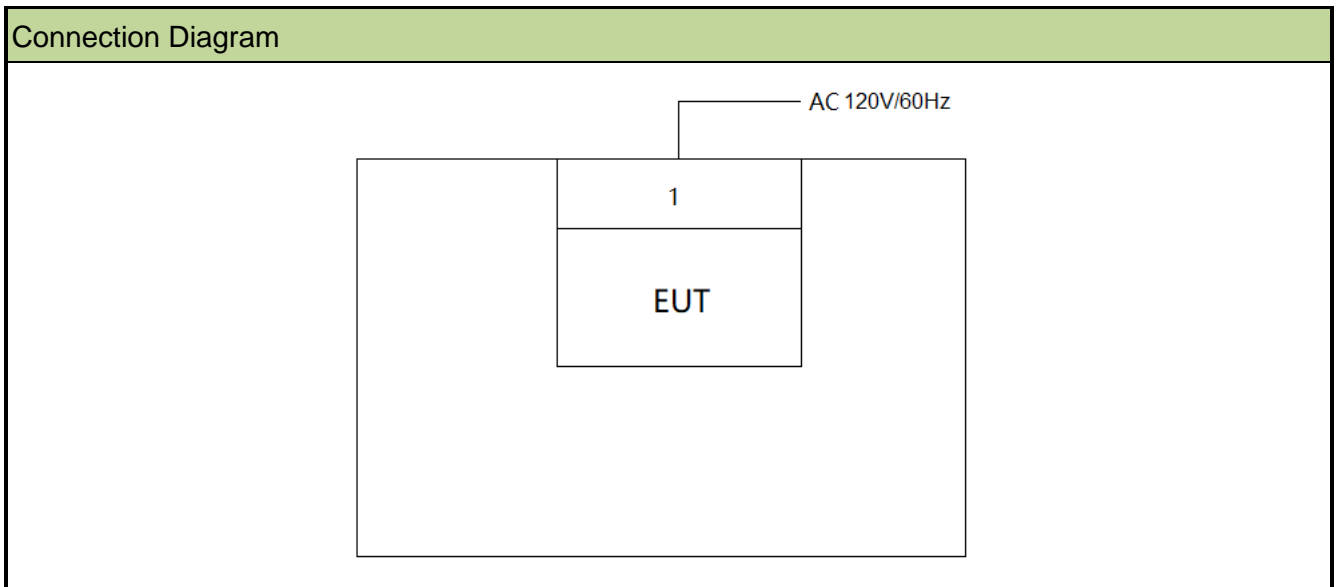

2.10. Test System Details

The types for all equipments, plus descriptions of all cables used in the tested system (including inserted cards) are:

Product	Manufacturer	Model No.	Serial No.
1 Charging base	roborock	CDZ11RR/CDZ12RR	N/A

3. ANTENNA REQUIREMENTS

Excerpt from §15.203 of the FCC Rules/Regulations:

“An intentional radiator antenna shall be designed to ensure that no antenna other than that furnished by the responsible party can be used with the device. The use of a permanently attached antenna or of an antenna that uses a unique coupling to the intentional radiator shall be considered sufficient to comply with the provisions of this section.”

- The antenna of the device is **permanently attached**.
- There are no provisions for connection to an external antenna.

Conclusion:

The unit complies with the requirement of §15.203.

4. TEST EQUIPMENT CALIBRATION DATE

Conducted Emission - WZ-SR2

Instrument	Manufacturer	Type No.	Asset No.	Cali. Interval	Cali. Due Date
EMI Test Receiver	R&S	ESR3	MRTSUE06185	1 year	2021/01/18
Two-Line V-Network	R&S	ENV216	MRTSUE06002	1 year	2021/09/09
Thermal Hygrometer	testo	608-H1	MRTSUE06404	1 year	2021/07/26
Shielding Room	MIX-BEP	Chamber-SR2	MRTSUE06215	N/A	N/A

Conducted Emission - SIP-SR2

Instrument	Manufacturer	Type No.	Asset No.	Cali. Interval	Cali. Due Date
EMI Test Receiver	R&S	ESR3	MRTSUE06613	1 year	2021/07/02
Two-Line V-Network	R&S	ENV216	MRTSUE06003	1 year	2021/09/09
Thermal Hygrometer	testo	608-H1	MRTSUE06621	1 year	2020/12/29

Radiated Emission - WZ-AC1

Instrument	Manufacturer	Type No.	Asset No.	Cali. Interval	Cali. Due Date
EMI Test Receiver	R&S	ESR7	MRTSUE06001	1 year	2021/01/18
PXA Signal Analyzer	Keysight	N9030B	MRTSUE06395	1 year	2021/08/30
Loop Antenna	Schwarzbeck	FMZB 1519	MRTSUE06025	1 year	2021/11/08
Bilog Period Antenna	Schwarzbeck	VULB 9168	MRTSUE06172	1 year	2021/08/08
Horn Antenna	Schwarzbeck	BBHA 9120D	MRTSUE06023	1 year	2021/09/27
Horn Antenna	Schwarzbeck	BBHA9170	MRTSUE06597	1 year	2020/12/17
Microwave System Amplifier	Agilent	83017A	MRTSUE06076	1 year	2020/11/15
Preamplifier	Schwarzbeck	BBV 9721	MRTSUE06121	1 year	2021/06/11
Thermal Hygrometer	testo	608-H1	MRTSUE06403	1 year	2021/07/26
Anechoic Chamber	TDK	Chamber-AC1	MRTSUE06212	1 year	2021/04/30

Radiated Emission - WZ-AC2

Instrument	Manufacturer	Type No.	Asset No.	Cali. Interval	Cali. Due Date
MXE EMI Receiver	Keysight	N9038A	MRTSUE06125	1 year	2021/07/02
Loop Antenna	Schwarzbeck	FMZB 1519	MRTSUE06025	1 year	2021/11/08
Bilog Period Antenna	Schwarzbeck	VULB 9162	MRTSUE06022	1 year	2021/05/26
Broad-Band Horn Antenna	Schwarzbeck	BBHA 9120D	MRTSUE06171	1 year	2021/10/25
Horn Antenna	Schwarzbeck	BBHA9170	MRTSUE06597	1 year	2020/12/17
Broadband Coaxial Preamplifier	Schwarzbeck	BBV 9718	MRTSUE06176	1 year	2020/11/15
Preamplifier	Schwarzbeck	BBV 9721	MRTSUE06121	1 year	2021/06/11
Thermal Hygrometer	Minggao	ETH529	MRTSUE06170	1 year	2020/12/15
Anechoic Chamber	RIKEN	Chamber-AC2	MRTSUE06213	1 year	2021/04/30

Radiated Emission - SIP-AC1

Instrument	Manufacturer	Type No.	Asset No.	Cali. Interval	Cali. Due Date
EMI Test Receiver	R&S	ESR3	MRTSUE06612	1 year	2021/07/02
EXA Signal Analyzer	Keysight	N9010B	MRTSUE06559	1 year	2021/07/23
Loop Antenna	Schwarzbeck	FMZB 1519	MRTSUE06025	1 year	2021/11/08
Bilog Period Antenna	Schwarzbeck	VULB9168	MRTSUE06645	1 year	2021/08/30
Double Ridged Horn Antenna	R&S	HF907	MRTSUE06610	1 year	2021/08/30
Preamplifier	EMCI	EMC051845SE	MRTSUE06600	1 year	2021/11/09
Thermal Hygrometer	testo	608-H1	MRTSUE06620	1 year	2020/12/29
Anechoic Chamber	RIKEN	SIP-AC1	MRTSUE06554	1 year	2020/12/25

Radiated Emission - SIP-AC2

Instrument	Manufacturer	Type No.	Asset No.	Cali. Interval	Cali. Due Date
EMI Test Receiver	R&S	ESR3	MRTSUE06613	1 year	2021/07/02
MXA Signal Analyzer	Keysight	N9020B	MRTSUE06604	1 year	2021/09/26
Loop Antenna	Schwarzbeck	FMZB 1519	MRTSUE06025	1 year	2021/11/08
Bilog Period Antenna	Schwarzbeck	VULB9168	MRTSUE06646	1 year	2021/08/30
Horn Antenna	Schwarzbeck	BBHA9120D	MRTSUE06648	1 year	2020/12/17
Horn Antenna	Schwarzbeck	BBHA9170	MRTSUE06599	1 year	2020/12/17
Preamplifier	EMCI	EMC051845SE	MRTSUE06644	1 year	2021/11/09
Preamplifier	EMCI	EMC184045SE	MRTSUE06602	1 year	2021/10/12
Thermal Hygrometer	testo	608-H1	MRTSUE06624	1 year	2020/12/29
Anechoic Chamber	RIKEN	SIP-AC2	MRTSUE06781	1 year	2020/12/25

Radiated Emission - SIP-AC3

Instrument	Manufacturer	Type No.	Asset No.	Cali. Interval	Cali. Due Date
EMI Test Receiver	R&S	ESR3	MRTSUE06612	1 year	2021/07/02
EXA Signal Analyzer	Keysight	N9010B	MRTSUE06559	1 year	2021/07/23
Loop Antenna	Schwarzbeck	FMZB 1519	MRTSUE06025	1 year	2021/11/08
Bilog Period Antenna	Schwarzbeck	VULB9168	MRTSUE06647	1 year	2021/08/08
Double Ridged Horn Antenna	R&S	HF907	MRTSUE06611	1 year	2021/09/13
Horn Antenna	Schwarzbeck	BBHA9170	MRTSUE06598	1 year	2020/12/17
Preamplifier	EMCI	EMC012645SE	MRTSUE06642	1 year	2021/01/16
Preamplifier	EMCI	EMC184045SE	MRTSUE06641	1 year	2021/01/16
Thermal Hygrometer	testo	608-H1	MRTSUE06622	1 year	2020/12/29
Anechoic Chamber	RIKEN	SIP-AC3	MRTSUE06782	1 year	2020/12/25

Conducted Test Equipment - WZ-TR3

Instrument	Manufacturer	Type No.	Asset No.	Cali. Interval	Cali. Due Date
EXA Signal Analyzer	Agilent	N9020A	MRTSUE06106	1 year	2021/04/14
EXA Signal Analyzer	Keysight	N9010B	MRTSUE06607	1 year	2021/01/08
Signal Analyzer	R&S	FSV40	MRTSUE06218	1 year	2021/04/14
Power Meter	Agilent	U2021XA	MRTSUE06030	1 year	2020/11/18
USB wideband power sensor	Keysight	U2021XA	MRTSUE06446	1 year	2021/08/30
USB wideband power sensor	Keysight	U2021XA	MRTSUE06447	1 year	2021/08/08
Bluetooth Test Set	Anritsu	MT8852B-042	MRTSUE06389	1 year	2021/06/11
Audio Analyzer	Agilent	U8903B	MRTSUE06143	1 year	2021/06/11
Modulation Analyzer	HP	HP8901A	MRTSUE06098	1 year	2021/09/26
Wideband Radio Communication Tester	R&S	CMW 500	MRTSUE06243	1 year	2021/10/20
DC Power Supply	GWINSTEK	DPS-3303C	MRTSUE06064	N/A	N/A
Temperature & Humidity Chamber	BAOYT	BYH-150CL	MRTSUE06051	1 year	2020/11/07
Thermal Hygrometer	testo	608-H1	MRTSUE06401	1 year	2021/07/26
Attenuator	MVE	6 dB	MRTSUE06534	1 year	2020/12/12
Attenuator	MVE	10 dB	MRTSUE06543	1 year	2020/12/12

Conducted Test Equipment - SIP-SR5

Instrument	Manufacturer	Type No.	Asset No.	Cali. Interval	Cali. Due Date
Signal Analyzer	R&S	FSV40	MRTSUE06218	1 year	2021/04/14
PXA Signal Analyzer	Keysight	N9030B	MRTSUE06395	1 year	2021/08/30
USB wideband power sensor	Agilent	U2021XA	MRTSUE06595	1 year	2021/09/26
USB wideband power sensor	Agilent	U2021XA	MRTSUE06596	1 year	2021/09/26
Wideband Radio Communication Tester	R&S	CMW 500	MRTSUE06243	1 year	2021/10/20
Bluetooth Test Set	Anritsu	MT8852B-042	MRTSUE06389	1 year	2021/06/11
Temperature Chamber	BAOYT	BYG-408CS	MRTSUE06847	1 year	2021/03/31
Thermal Hygrometer	testo	622	MRTSUE06629	1 year	2020/12/30

Software	Version	Function
EMI Software	V3	EMI Test Software

5. MEASUREMENT UNCERTAINTY

Where relevant, the following test uncertainty levels have been estimated for tests performed on the EUT as specified in CISPR 16-4-2. This uncertainty represents an expanded uncertainty expressed at approximately the 95% confidence level using a coverage factor of $k = 2$.

AC Conducted Emission Measurement
Measurement Uncertainty for a Level of Confidence of 95% ($U=2Uc(y)$): 9kHz~150kHz: 3.74dB 150kHz~30MHz: 3.44dB
Radiated Disturbance
Measurement Uncertainty for a Level of Confidence of 95% ($U=2Uc(y)$): Horizontal: 30MHz~300MHz: 5.04dB 300MHz~1GHz: 4.95dB 1GHz~40GHz: 6.40dB Vertical: 30MHz~300MHz: 5.24dB 300MHz~1GHz: 6.03dB 1GHz~40GHz: 6.40dB
Spurious Emissions, Conducted
Measuring Uncertainty for a Level of Confidence of 95% ($U=2Uc(y)$): 0.78dB
Output Power
Measuring Uncertainty for a Level of Confidence of 95% ($U=2Uc(y)$): 1.13dB
Power Spectrum Density
Measuring Uncertainty for a Level of Confidence of 95% ($U=2Uc(y)$): 1.15dB
Occupied Bandwidth
Measuring Uncertainty for a Level of Confidence of 95% ($U=2Uc(y)$): 0.28%

6. TEST RESULT

6.1. Summary

FCC Part Section(s)	RSS Section(s)	Test Description	Test Limit	Test Condition	Test Result	Reference
15.247(a)(2)	RSS-247 [5.2]	6dB Bandwidth	$\geq 500\text{kHz}$	Conducted	Pass	Section 6.2
N/A	RSS-Gen [6.7]	99% Bandwidth	N/A		Pass	
15.247(b)(3)	RSS-247 [5.4(d)]	Output Power	$\leq 1\text{Watt}$ & $\text{EIRP} \leq 4\text{Watt}$		Pass	Section 6.3
15.247(e)	RSS-247 [5.2]	Power Spectral Density	$\leq 8\text{dBm} / 3\text{kHz}$		Pass	Section 6.4
15.247(d)	RSS-247 [5.5]	Band Edge / Out-of-Band Emissions	$\geq 20\text{dBc}$ (Peak)		Pass	Section 6.5
15.205 15.209	RSS-247 [5.5]	General Field Strength (Restricted Bands and Radiated Emission)	Emissions in restricted bands must meet the radiated limits detailed in 15.209	Radiated	Pass	Section 6.6 & 6.7
15.207	RSS-Gen [8.8]	AC Conducted Emissions 150kHz - 30MHz	$< \text{FCC } 15.207$ limits	Line Conducted	Pass	Section 6.8

Notes:

- 1) The analyzer plots shown in this section were all taken with a correction table loaded into the analyzer. The correction table was used to account for the losses of the cables and attenuators used as part of the system to connect the EUT to the analyzer at all frequencies of interest.
- 2) All modes of operation and data rates were investigated. For radiated emission test, every axis (X, Y, Z) was also verified. The test results shown in the following sections represent the worst case emissions.

6.2. Occupied Bandwidth Measurement

6.2.1. Test Limit

The minimum 6dB bandwidth shall be at least 500 kHz.

6.2.2. Test Procedure used

ANSI C63.10-2013 - Section 11.8 (6dB bandwidth)

ANSI C63.10-2013 - Section 6.9.3 (99% bandwidth)

6.2.3. Test Setting

For 6dB bandwidth

1. The Spectrum's automatic bandwidth measurement capability was used to perform the 6dB bandwidth measurement. The "X" dB bandwidth parameter was set to $X = 6$. The bandwidth measurement was not influenced by any intermediate power nulls in the fundamental emission.
2. Set RBW = 100 kHz
3. $VBW \geq 3 \times RBW$
4. Detector = Peak
5. Trace mode = Max hold
6. Sweep = Auto couple
7. Allow the trace was allowed to stabilize

For 99% bandwidth

1. Span = 1.5 times to 5 times the OBW
2. Set RBW = 1% to 5% the OBW
3. $VBW \geq 3 \times RBW$
4. Detector = Peak
5. Trace mode = Max hold
6. Sweep = Auto couple
7. Allow the trace was allowed to stabilize

6.2.4. Test Setup

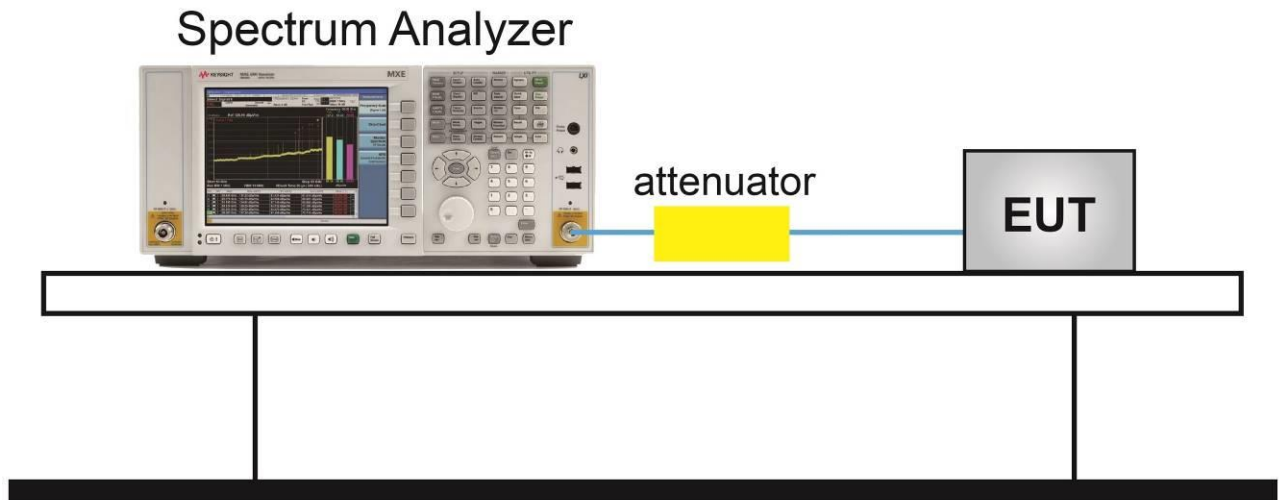

6.2.5. Test Result

Product	Robotic Vacuum Cleaner	Test Engineer	Ternence Wang
Test Site	WZ-TR3	Test Date	2020/09/26

Test Mode	Data Rate / MCS	Channel No.	Frequency (MHz)	6dB Bandwidth (MHz)	Limit (MHz)	Result
802.11b	1Mbps	01	2412	8.61	≥ 0.5	Pass
802.11b	1Mbps	06	2437	9.55	≥ 0.5	Pass
802.11b	1Mbps	11	2462	9.10	≥ 0.5	Pass
802.11g	6Mbps	01	2412	16.58	≥ 0.5	Pass
802.11g	6Mbps	06	2437	16.56	≥ 0.5	Pass
802.11g	6Mbps	11	2462	16.55	≥ 0.5	Pass
802.11n-HT20	MCS0	01	2412	17.74	≥ 0.5	Pass
802.11n-HT20	MCS0	06	2437	17.63	≥ 0.5	Pass
802.11n-HT20	MCS0	11	2462	17.76	≥ 0.5	Pass
802.11n-HT40	MCS0	03	2422	36.45	≥ 0.5	Pass
802.11n-HT40	MCS0	06	2437	36.45	≥ 0.5	Pass
802.11n-HT40	MCS0	09	2452	36.42	≥ 0.5	Pass

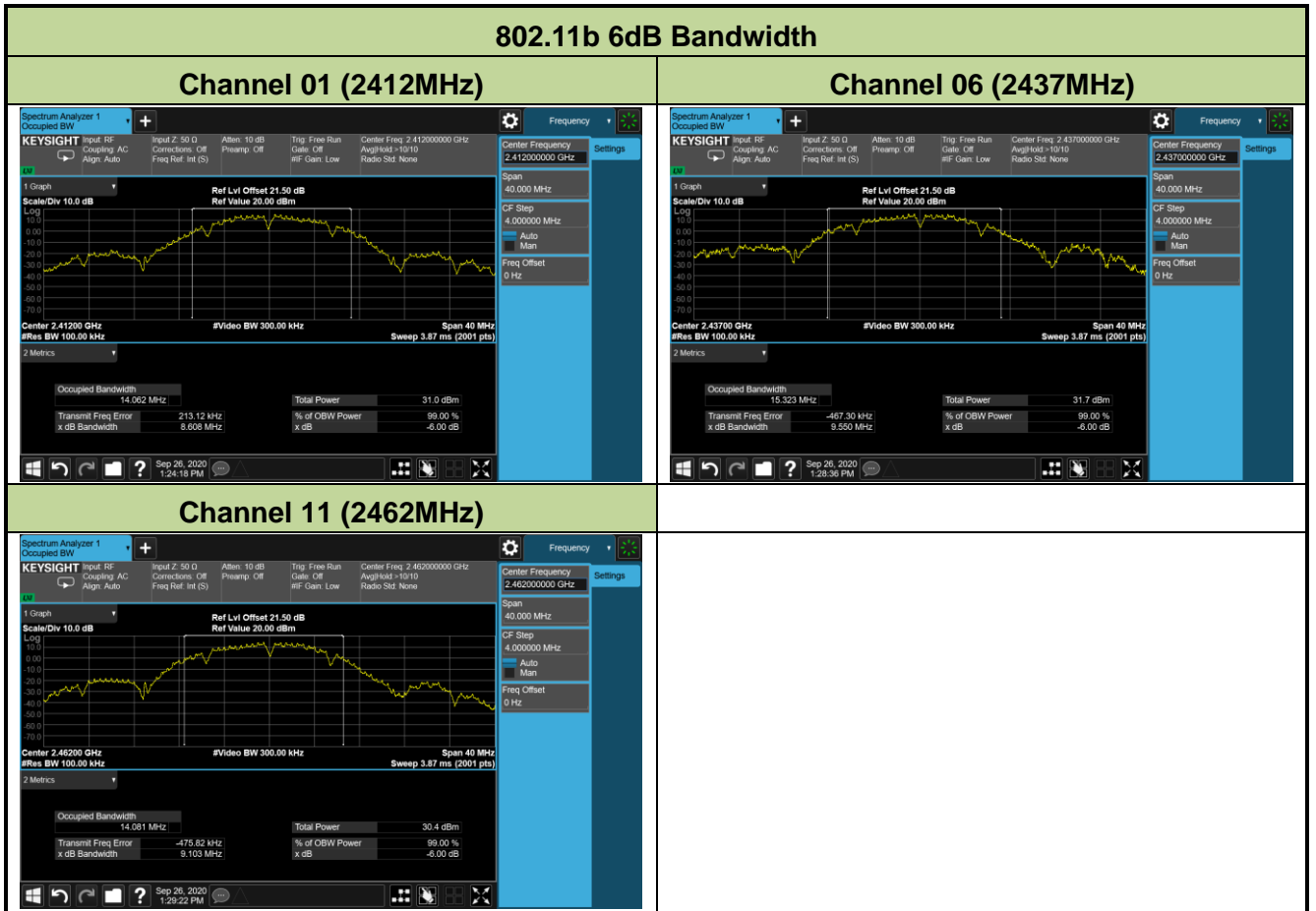

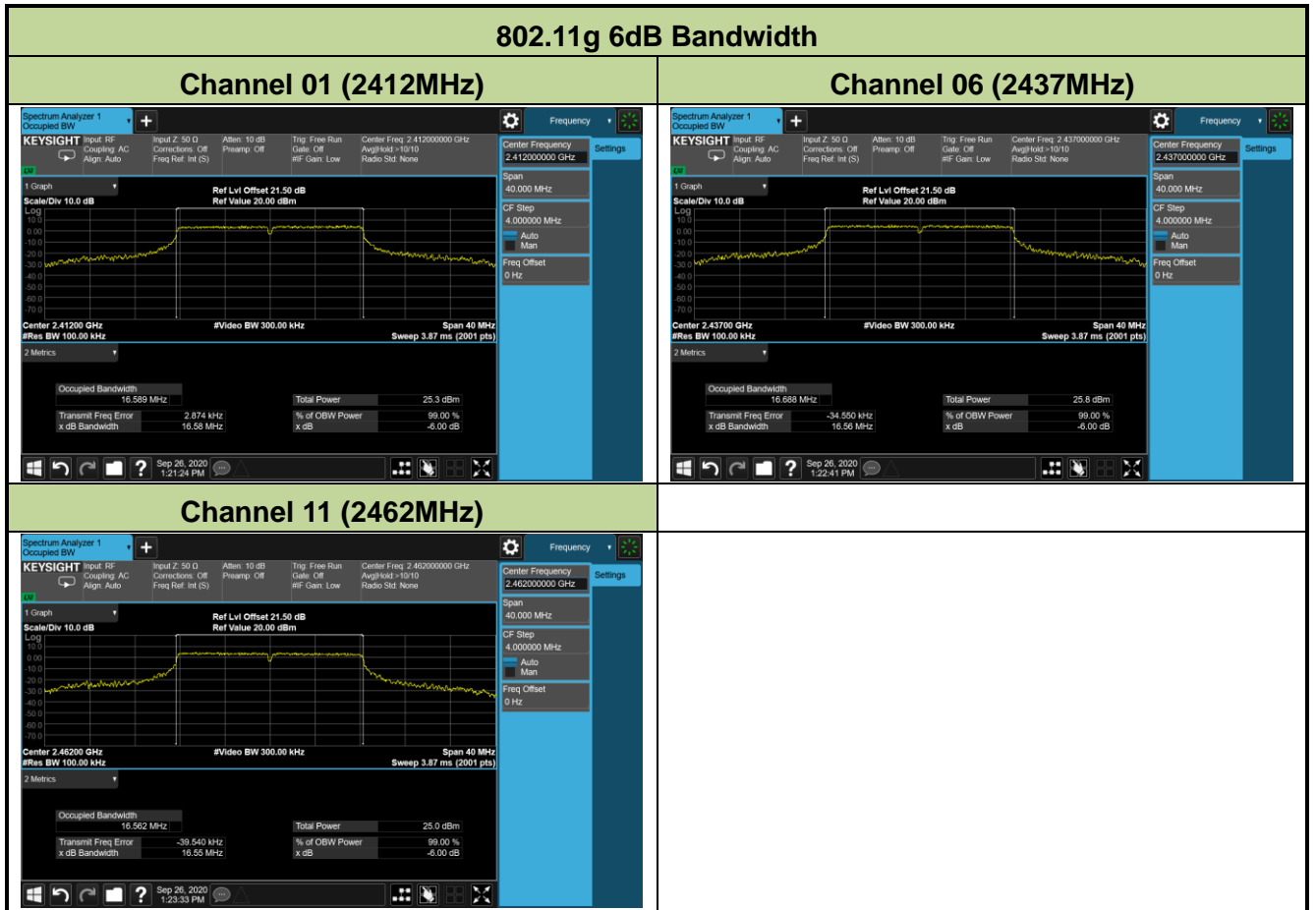

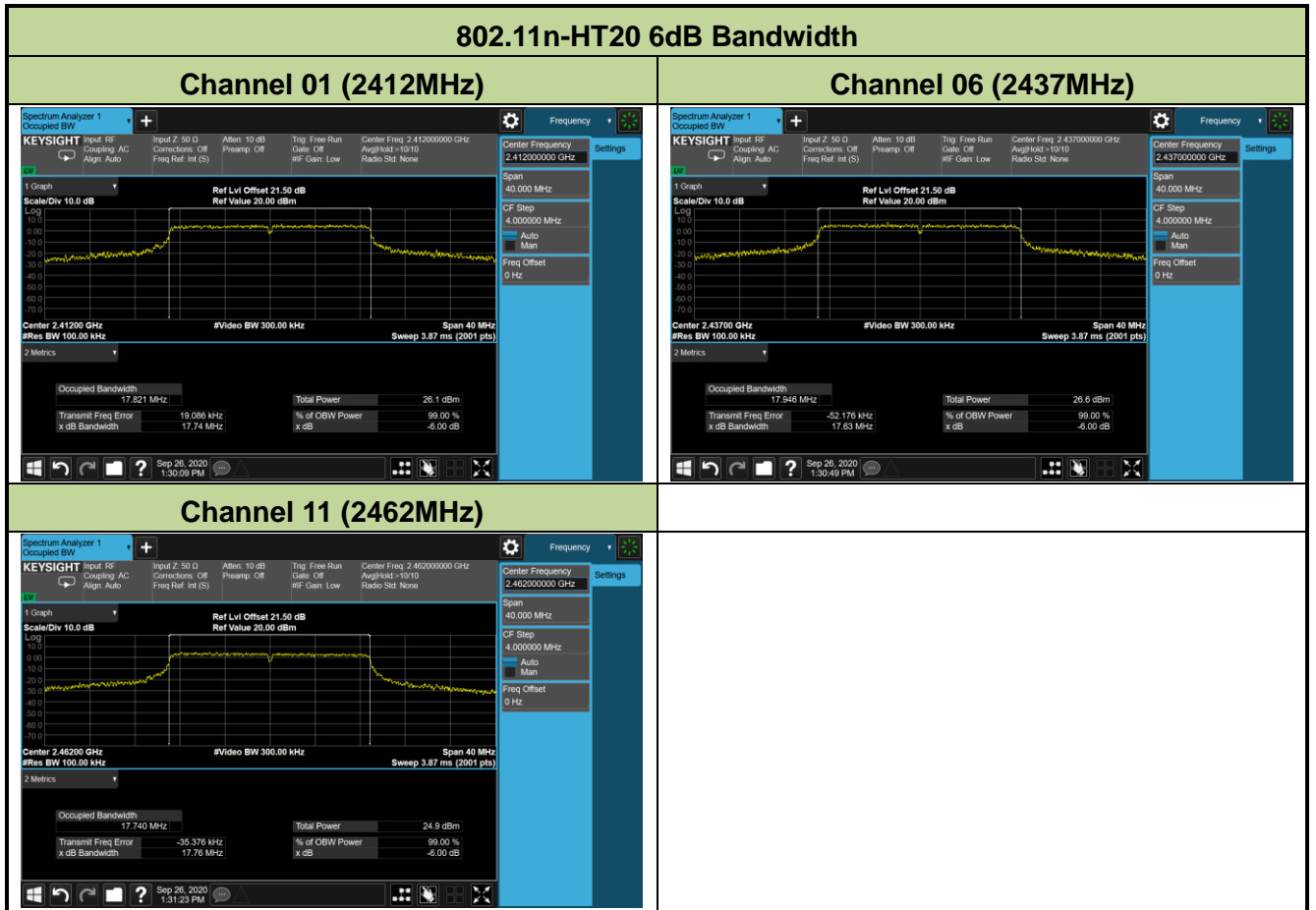

802.11n-HT40 6dB Bandwidth

Channel 03 (2422MHz)

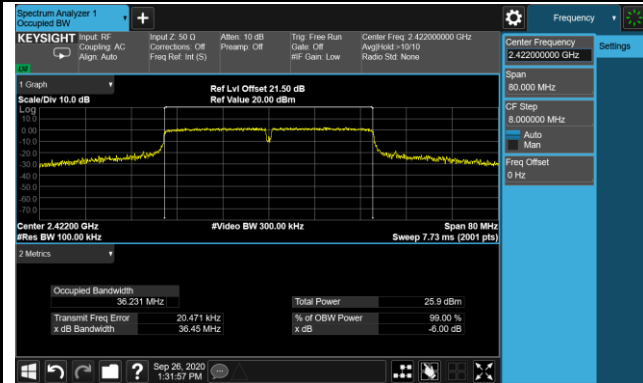

Channel 06 (2437MHz)

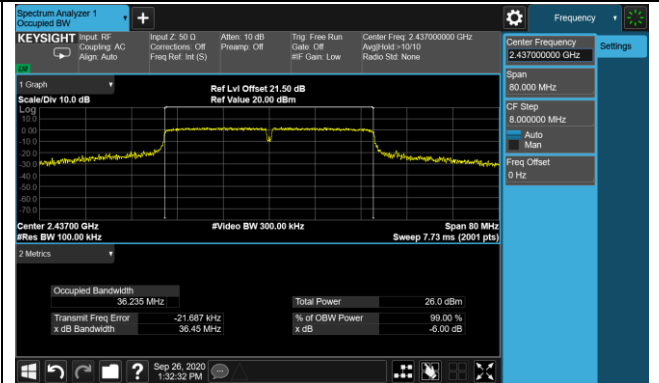

Channel 09 (2452MHz)

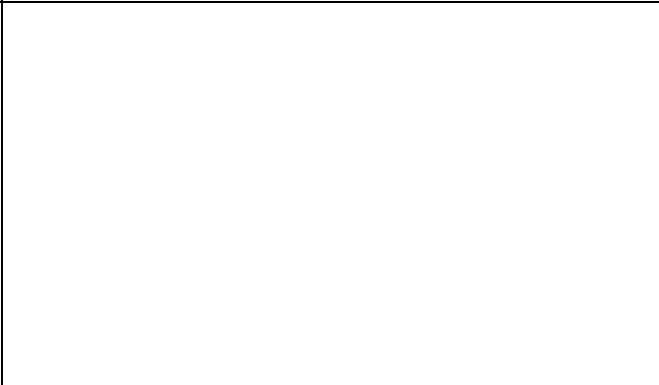
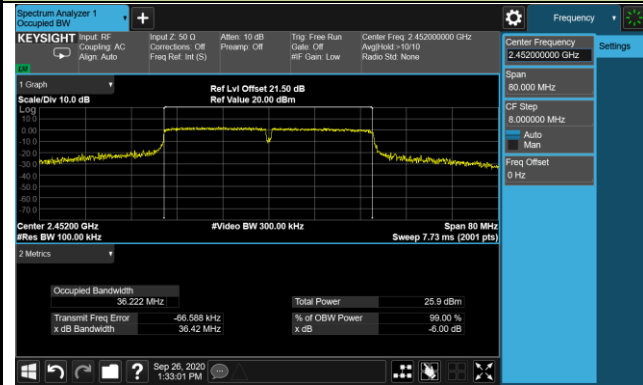

Product	Robotic Vacuum Cleaner	Test Engineer	Ternence Wang
Test Site	WZ-TR3	Test Date	2020/11/16

Test Mode	Data Rate / MCS	Channel No.	Frequency (MHz)	99% Bandwidth (MHz)
802.11b	1Mbps	01	2412	13.53
802.11b	1Mbps	06	2437	13.56
802.11b	1Mbps	11	2462	13.50
802.11g	6Mbps	01	2412	16.61
802.11g	6Mbps	06	2437	17.28
802.11g	6Mbps	11	2462	16.90
802.11n-HT20	MCS0	01	2412	17.76
802.11n-HT20	MCS0	06	2437	18.02
802.11n-HT20	MCS0	11	2462	17.90
802.11n-HT40	MCS0	03	2422	36.16
802.11n-HT40	MCS0	06	2437	36.62
802.11n-HT40	MCS0	09	2452	36.20

802.11b 99% Bandwidth

Channel 01 (2412MHz)

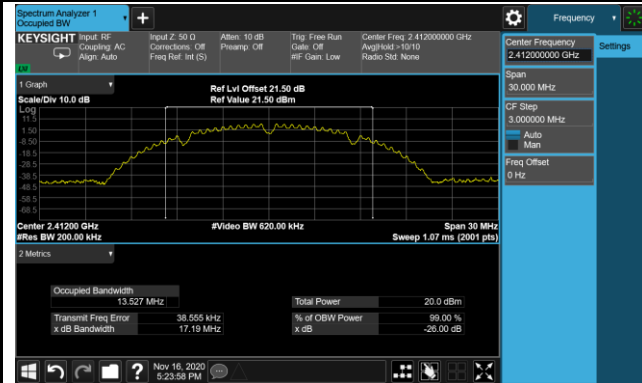

Channel 06 (2437MHz)

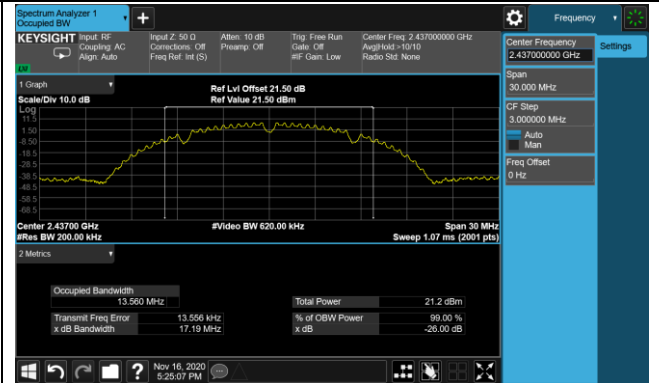

Channel 11 (2462MHz)

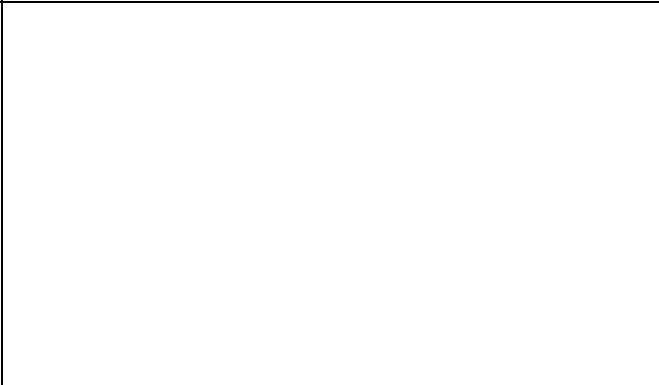
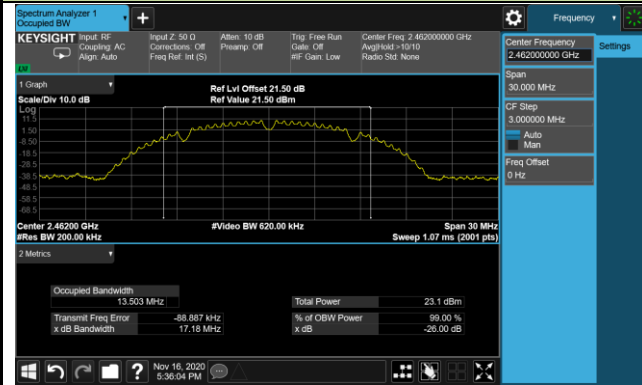

802.11g 99% Bandwidth

Channel 01 (2412MHz)

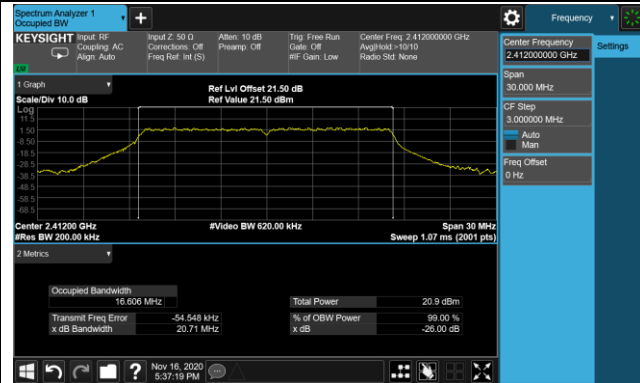

Channel 06 (2437MHz)

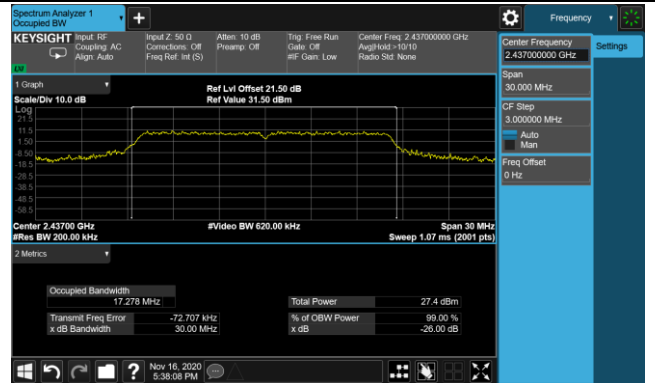

Channel 11 (2462MHz)

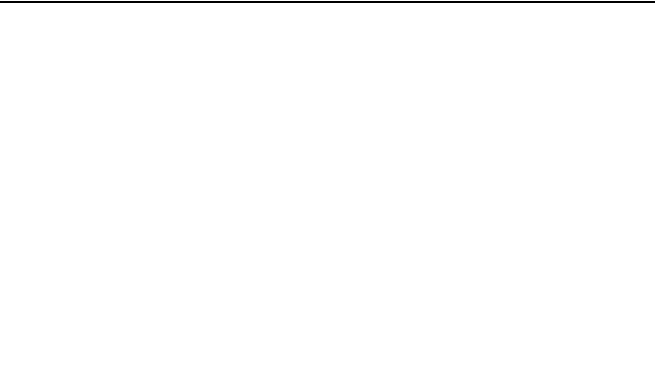
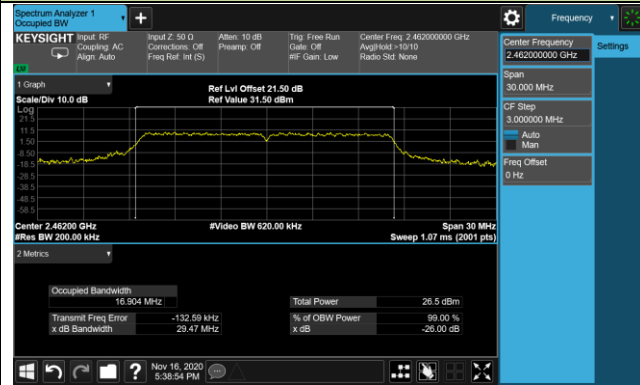

802.11n-HT20 99% Bandwidth

Channel 01 (2412MHz)

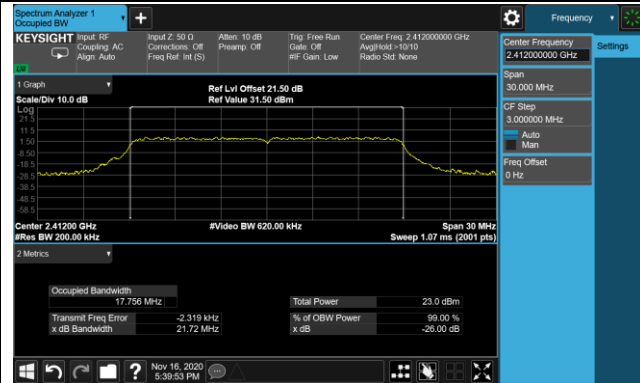

Channel 06 (2437MHz)

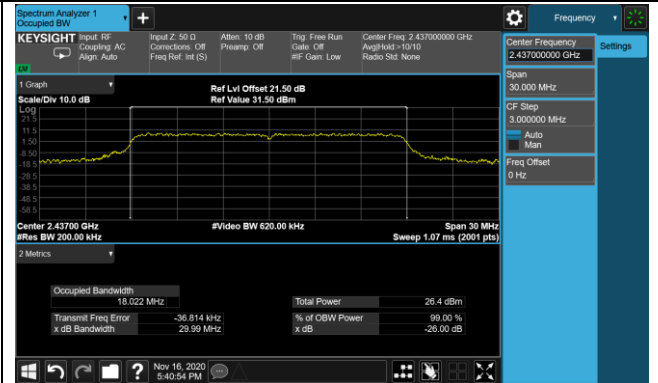

Channel 11 (2462MHz)

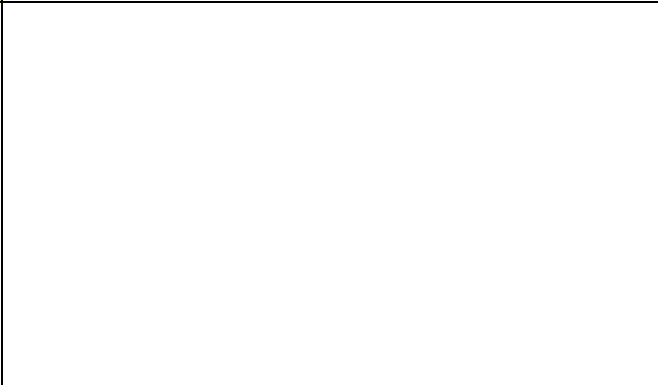
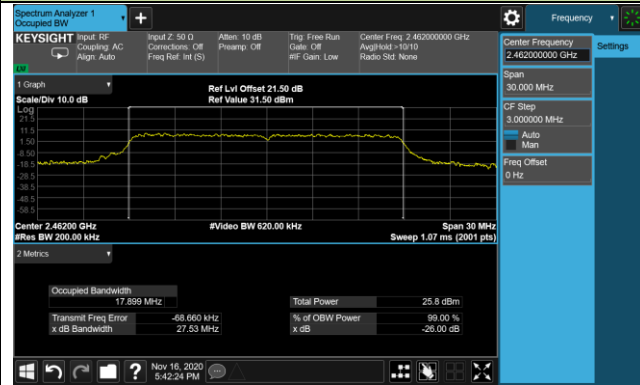

802.11n-HT40 99% Bandwidth

Channel 03 (2422MHz)

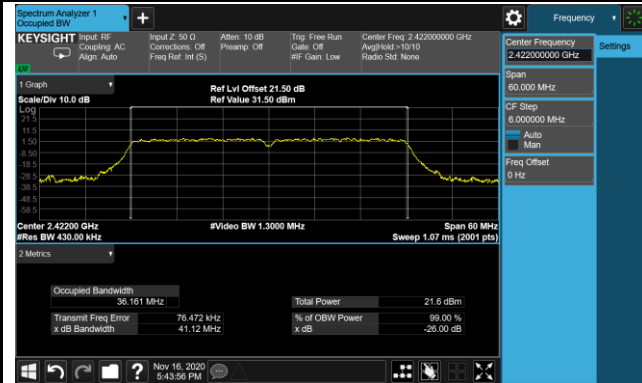

Channel 06 (2437MHz)

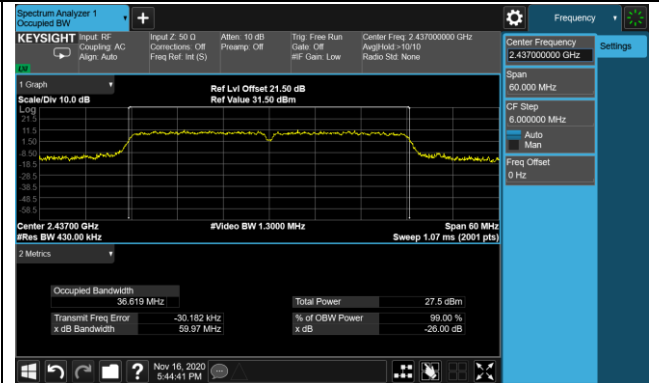

Channel 09 (2452MHz)

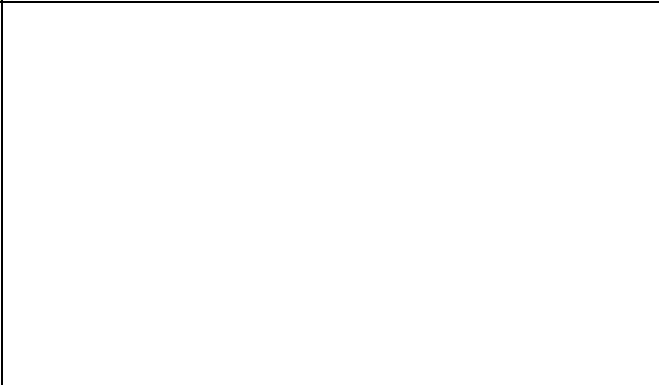
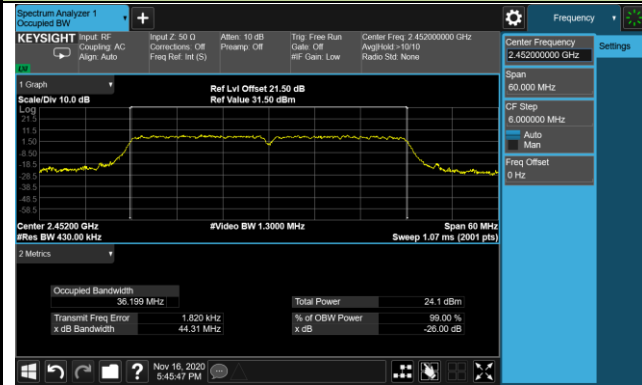

6.3. Output Power Measurement

6.3.1. Test Limit

The maximum conducted output power shall not exceed 1 Watt (30dBm) and the E.I.R.P shall not exceed 4 Watt (36dBm).

6.3.2. Test Procedure Used

ANSI C63.10-2013 - Section 11.9.1.3

ANSI C63.10-2013 - Section 11.9.2.3.2

6.3.3. Test Setting

Method PKPM1 (Peak Power Measurement)

Peak power measurements were performed only when the EUT was transmitting at its maximum power control level using a broadband power meter with a pulse sensor. The pulse sensor employs a VBW = 50MHz so this method was only used for signals whose DTS bandwidth was less than or equal to 50MHz.

Method AVGPM-G (Measurement using a gated RF average-reading power meter)

Measurements may be performed using a wideband gated RF power meter provided that the gate parameters are adjusted such that the power is measured only when the EUT is transmitting at its maximum power control level. Since this measurement is made only during the ON time of the transmitter, no duty cycle correction is required.

6.3.4. Test Setup

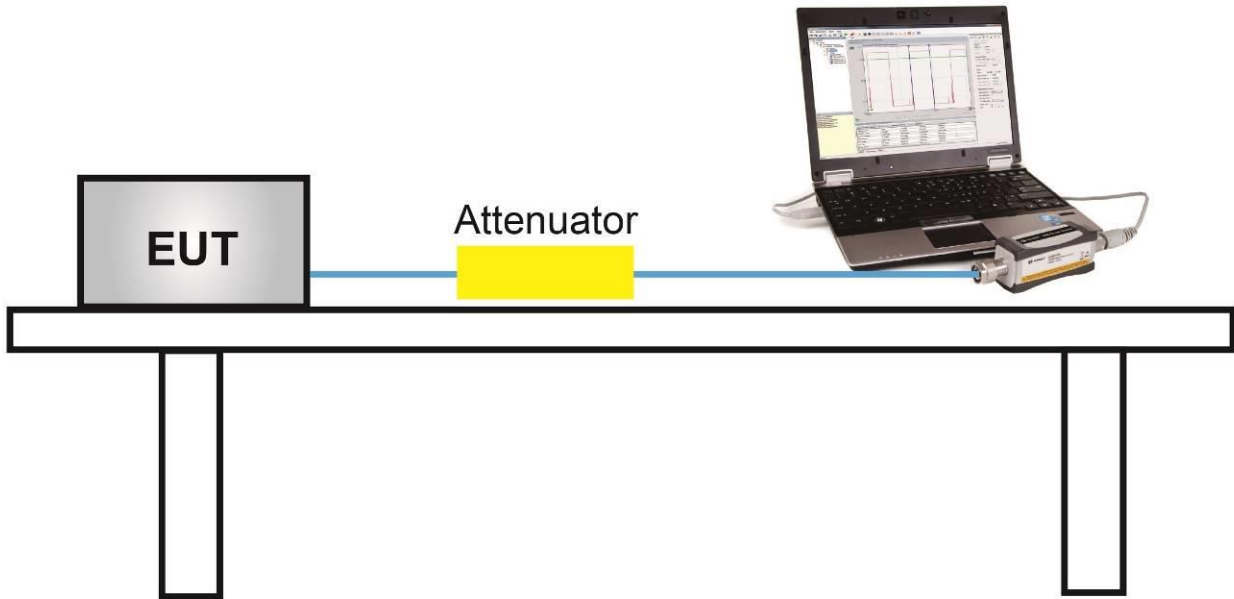

6.3.5. Test Result

Power output test was verified over all data rates of each mode shown as below, and then choose the maximum power output (gray marker) for final test of each channel.

Test Mode	Bandwidth (MHz)	Channel No.	Frequency (MHz)	Data Rate / MCS	Average Power (dBm)
802.11b	20	6	2437	1Mbps	16.03
				5.5Mbps	15.92
				11Mbps	15.84
802.11g	20	6	2437	6Mbps	20.53
				24Mbps	20.41
				54Mbps	20.33
802.11n	20	6	2437	MCS0	20.35
				MCS3	20.26
				MCS7	20.13
802.11n	40	6	2437	MCS0	20.18
				MCS3	20.09
				MCS7	20.01

Product	Robotic Vacuum Cleaner	Test Engineer	Ternence Wang
Test Site	WZ-TR3	Test Date	2020/09/26

Test Result of Peak Output Power

Test Mode	Data Rate / MCS	Channel No.	Freq. (MHz)	Peak Power (dBm)	Limit (dBm)	E.I.R.P (dBm)	E.I.R.P Limit (dBm)	Result
11b	1Mbps	01	2412	17.92	≤ 30.00	21.76	≤36.00	Pass
11b	1Mbps	06	2437	18.80	≤ 30.00	22.64	≤36.00	Pass
11b	1Mbps	11	2462	20.44	≤ 30.00	24.28	≤36.00	Pass
11g	6Mbps	01	2412	24.12	≤ 30.00	27.96	≤36.00	Pass
11g	6Mbps	06	2437	26.83	≤ 30.00	30.67	≤36.00	Pass
11g	6Mbps	11	2462	26.73	≤ 30.00	30.57	≤36.00	Pass
11n-HT20	MCS0	01	2412	25.37	≤ 30.00	29.21	≤36.00	Pass
11n-HT20	MCS0	06	2437	26.74	≤ 30.00	30.58	≤36.00	Pass
11n-HT20	MCS0	11	2462	26.53	≤ 30.00	30.37	≤36.00	Pass
11n-HT40	MCS0	03	2422	23.53	≤ 30.00	27.37	≤36.00	Pass
11n-HT40	MCS0	06	2437	26.73	≤ 30.00	30.57	≤36.00	Pass
11n-HT40	MCS0	09	2452	25.67	≤ 30.00	29.51	≤36.00	Pass

Note: E.I.R.P (dBm) = Peak Power (dBm) + Antenna Gain (dBi), Antenna Gain = 3.84 dBi.

Test Result of Average Output Power (Reporting Only)

Test Mode	Data Rate / MCS	Channel No.	Freq. (MHz)	Average Power (dBm)	Limit (dBm)	E.I.R.P (dBm)	E.I.R.P Limit (dBm)	Result
11b	1Mbps	01	2412	15.13	≤ 30.00	18.97	≤36.00	Pass
11b	1Mbps	06	2437	16.03	≤ 30.00	19.87	≤36.00	Pass
11b	1Mbps	11	2462	17.62	≤ 30.00	21.46	≤36.00	Pass
11g	6Mbps	01	2412	14.38	≤ 30.00	18.22	≤36.00	Pass
11g	6Mbps	06	2437	20.53	≤ 30.00	24.37	≤36.00	Pass
11g	6Mbps	11	2462	19.57	≤ 30.00	23.41	≤36.00	Pass
11n-HT20	MCS0	01	2412	16.68	≤ 30.00	20.52	≤36.00	Pass
11n-HT20	MCS0	06	2437	20.35	≤ 30.00	24.19	≤36.00	Pass
11n-HT20	MCS0	11	2462	19.39	≤ 30.00	23.23	≤36.00	Pass
11n-HT40	MCS0	03	2422	14.87	≤ 30.00	18.71	≤36.00	Pass
11n-HT40	MCS0	06	2437	20.18	≤ 30.00	24.02	≤36.00	Pass
11n-HT40	MCS0	09	2452	17.34	≤ 30.00	21.18	≤36.00	Pass

Note: E.I.R.P (dBm) = Average Power (dBm) + Antenna Gain (dBi), Antenna Gain = 3.84 dBi.

6.4. Power Spectral Density Measurement

6.4.1. Test Limit

The maximum permissible power spectral density is 8dBm in any 3 kHz band.

The same method of determining the conducted output power shall be used to determine the power spectral density.

6.4.2. Test Procedure Used

ANSI C63.10-2013 - Section 11.10.3& 11.10.5

6.4.3. Test Setting

1. Analyzer was set to the center frequency of the DTS channel under investigation
2. Span \geq 1.5 times the OBW
3. RBW = 3kHz
4. VBW = 10kHz
5. Detector = Peak
6. Sweep time = Auto couple
7. Trace mode = Max hold
8. Trace was allowed to stabilize

6.4.4. Test Setup

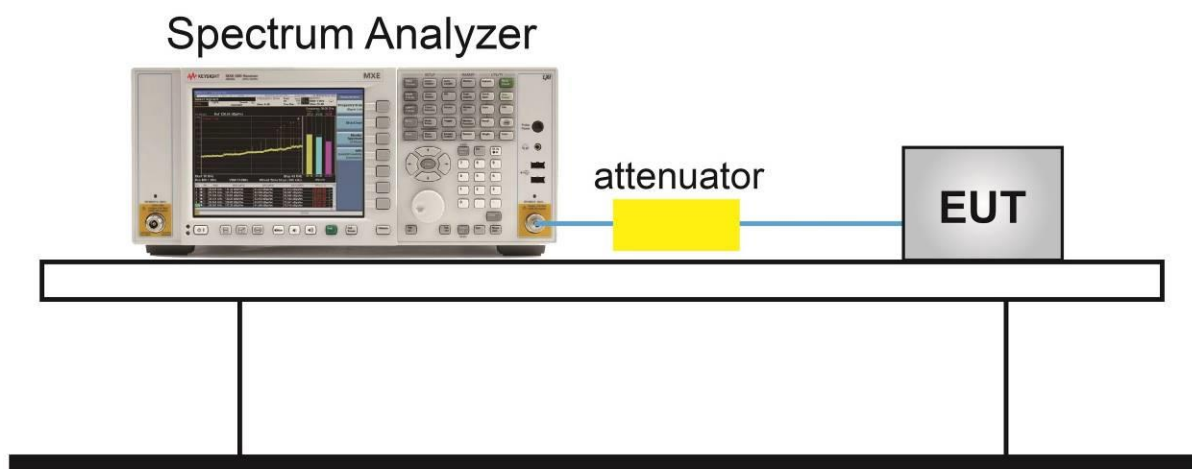

6.4.5. Test Result

Product	Robotic Vacuum Cleaner	Test Engineer	Ternence Wang
Test Site	WZ-TR3	Test Date	2020/09/26~2020/10/10

Test Mode	Data Rate (Mbps)	Channel No.	Frequency (MHz)	PSD Result (dBm / 3kHz)	Limit (dBm / 3kHz)	Result
11b	1Mbps	01	2412	-14.09	≤ 8.00	Pass
11b	1Mbps	06	2437	-12.92	≤ 8.00	Pass
11b	1Mbps	11	2462	-11.73	≤ 8.00	Pass
11g	6Mbps	01	2412	-14.26	≤ 8.00	Pass
11g	6Mbps	06	2437	-8.54	≤ 8.00	Pass
11g	6Mbps	11	2462	-9.14	≤ 8.00	Pass
11n-HT20	MCS0	01	2412	-11.39	≤ 8.00	Pass
11n-HT20	MCS0	06	2437	-7.94	≤ 8.00	Pass
11n-HT20	MCS0	11	2462	-9.09	≤ 8.00	Pass
11n-HT40	MCS0	03	2422	-9.06	≤ 8.00	Pass
11n-HT40	MCS0	06	2437	-9.20	≤ 8.00	Pass
11n-HT40	MCS0	09	2452	-11.49	≤ 8.00	Pass

802.11b Peak PSD

Channel 01 (2412MHz)

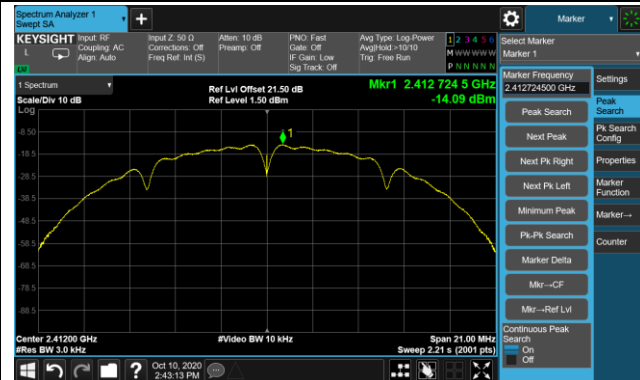

Channel 06 (2437MHz)



Channel 11 (2462MHz)

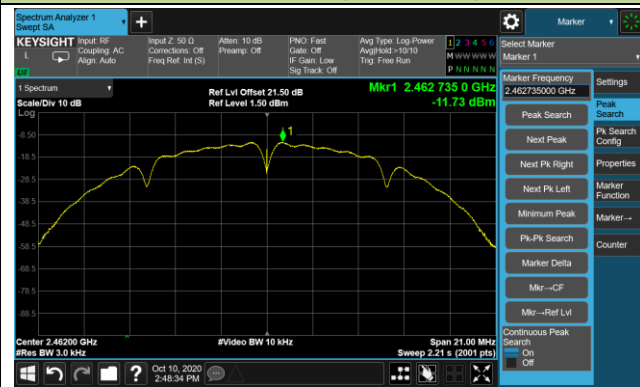

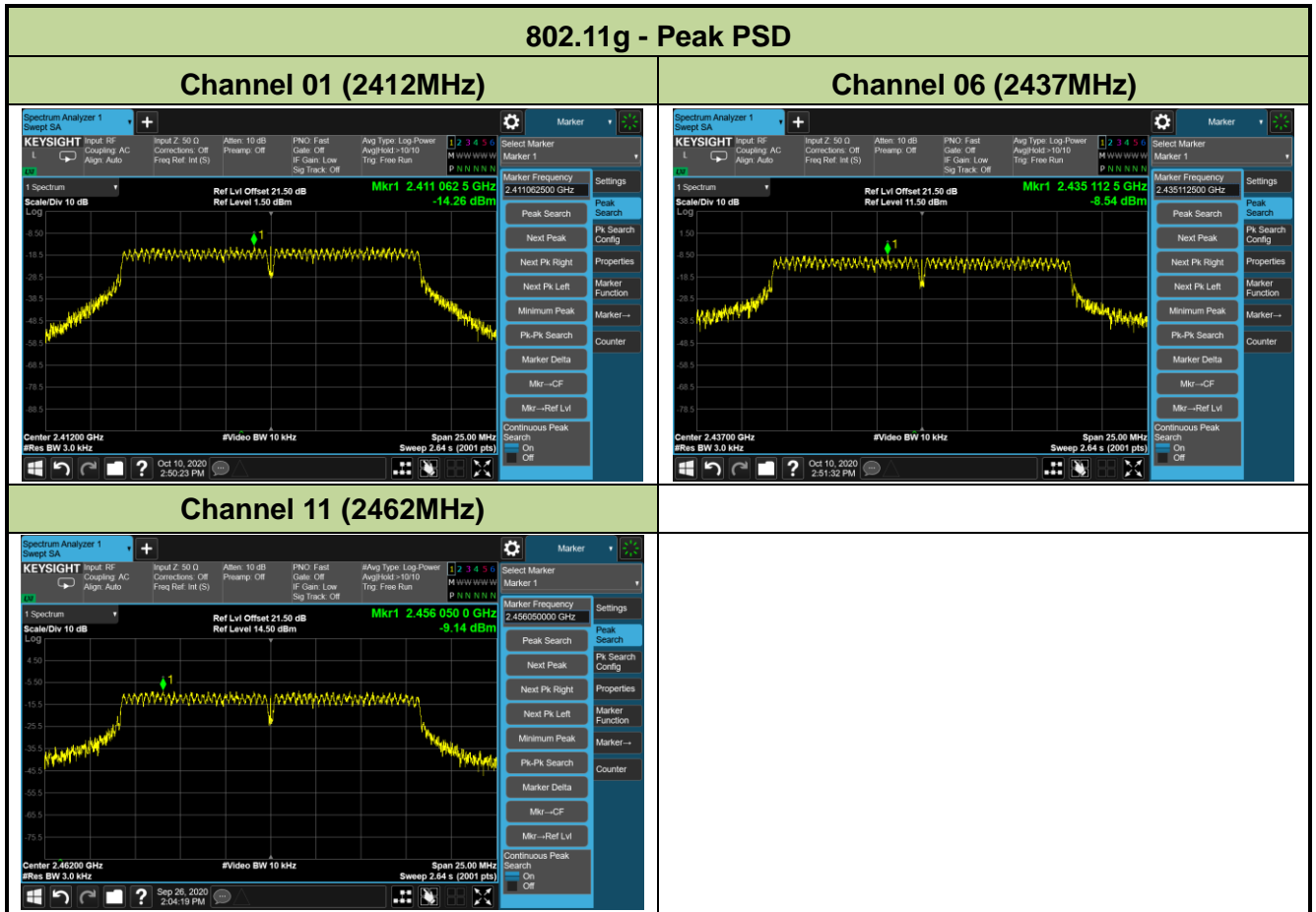

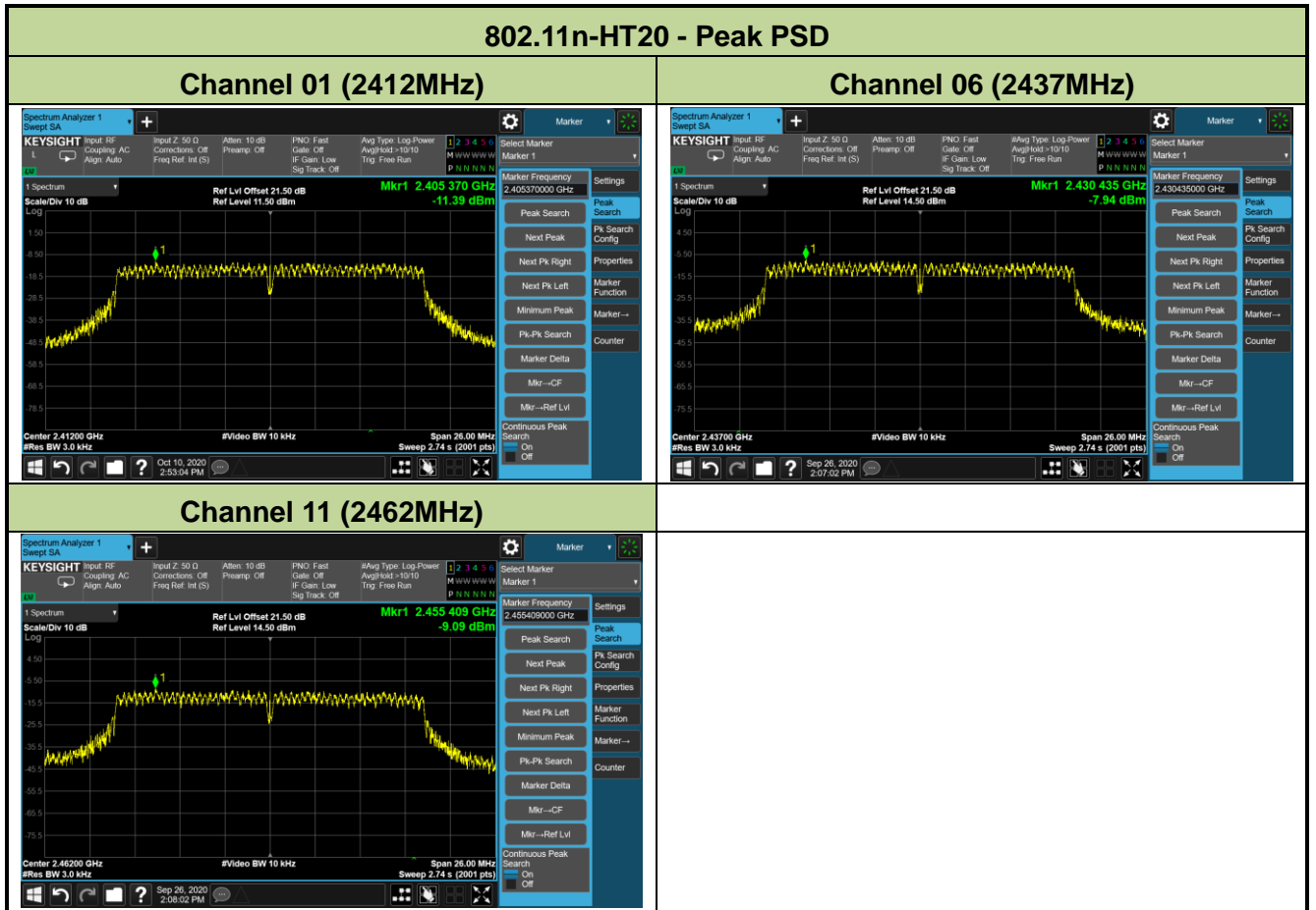

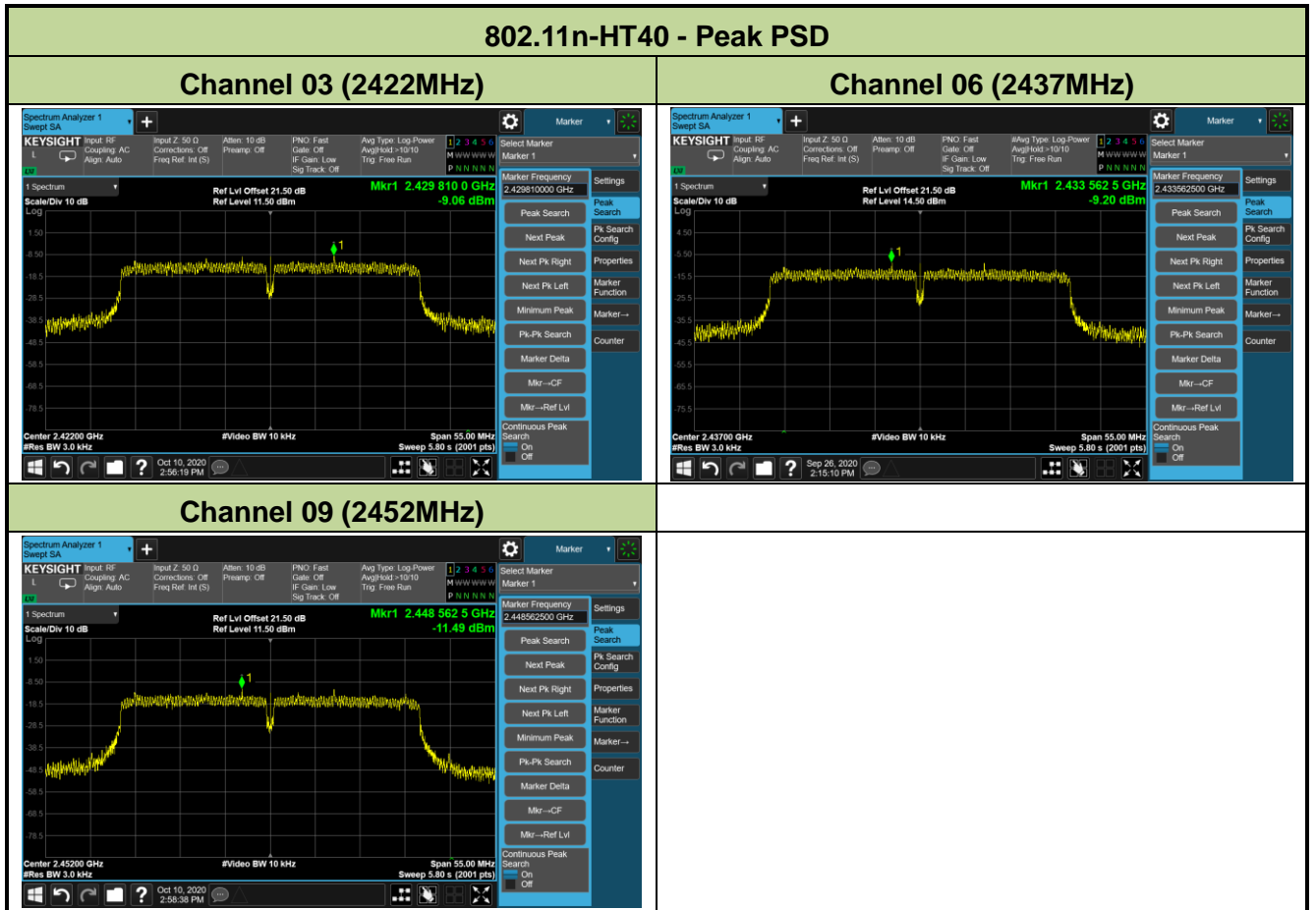

6.5. Conducted Band Edge and Out-of-Band Emissions

6.5.1. Test Limit

The limit for out-of-band spurious emissions at the band edge is 20dB below the fundamental emission level, as determined from the in-band power measurement of the DTS channel performed in a 100 kHz bandwidth per the PSD procedure.

6.5.2. Test Procedure Used

ANSI C63.10-2013 - Section 11.11

6.5.3. Test Setting

Reference level measurement

1. Set instrument center frequency to DTS channel center frequency
2. Set the span to ≥ 1.5 times the DTS bandwidth
3. Set the RBW = 100 kHz
4. Set the VBW $\geq 3 \times$ RBW
5. Detector = peak
6. Sweep time = auto couple
7. Trace mode = max hold
8. Allow trace to fully stabilize

Emission level measurement

1. Set the center frequency and span to encompass frequency range to be measured
2. RBW = 100kHz
3. VBW = 300kHz
4. Detector = Peak
5. Trace mode = max hold
6. Sweep time = auto couple
7. The trace was allowed to stabilize

6.5.4. Test Setup

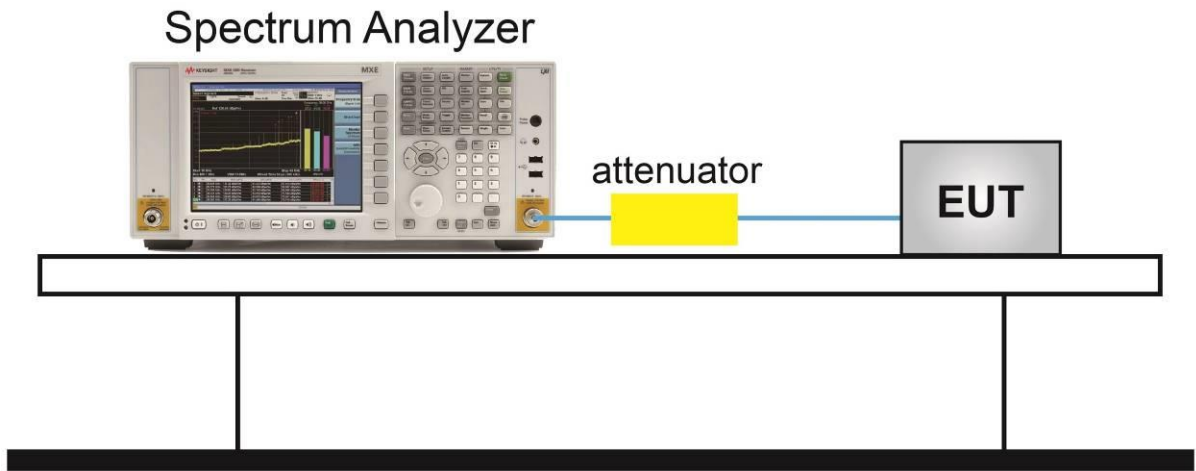

6.5.5. Test Result

Product	Robotic Vacuum Cleaner	Test Engineer	Ternence Wang
Test Site	WZ-TR3	Test Date	2020/09/26~2020/10/10

Test Mode	Data Rate / MCS	Channel No.	Frequency (MHz)	Limit	Result
802.11b	1Mbps	01	2412	20dBc	Pass
802.11b	1Mbps	06	2437	20dBc	Pass
802.11b	1Mbps	11	2462	20dBc	Pass
802.11g	6Mbps	01	2412	20dBc	Pass
802.11g	6Mbps	06	2437	20dBc	Pass
802.11g	6Mbps	11	2462	20dBc	Pass
802.11n-HT20	MCS0	01	2412	20dBc	Pass
802.11n-HT20	MCS0	06	2437	20dBc	Pass
802.11n-HT20	MCS0	11	2462	20dBc	Pass
802.11n-HT40	MCS0	03	2422	20dBc	Pass
802.11n-HT40	MCS0	06	2437	20dBc	Pass
802.11n-HT40	MCS0	09	2452	20dBc	Pass

802.11b Out-of-Band Emissions Channel 01 (2412MHz)

100kHz PSD Reference Level

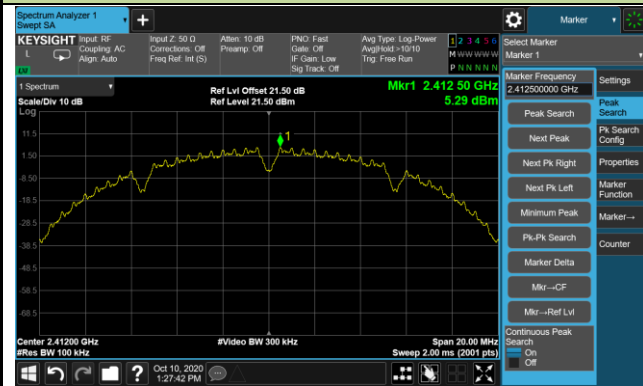

Low Band Edge

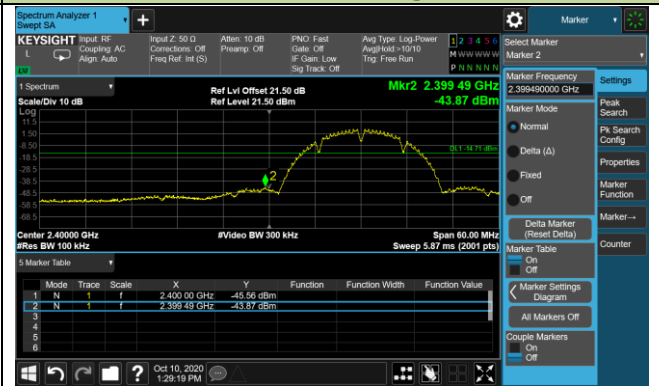

Spurious Emission

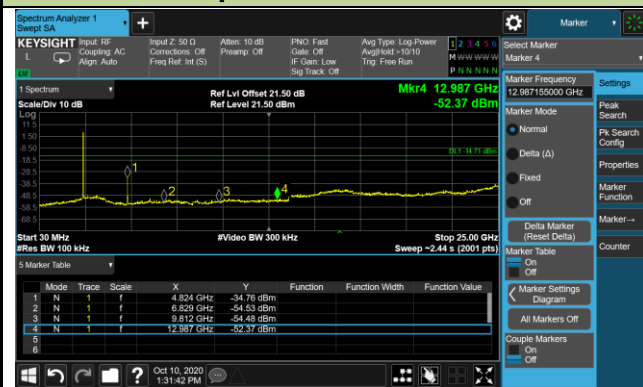

Channel 06 (2437MHz)

100kHz PSD Reference Level

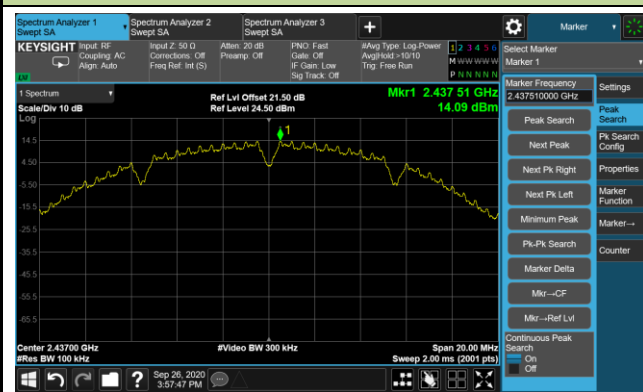

Spurious Emission



802.11b Out-of-Band Emissions

Channel 11 (2462MHz)

100kHz PSD Reference Level

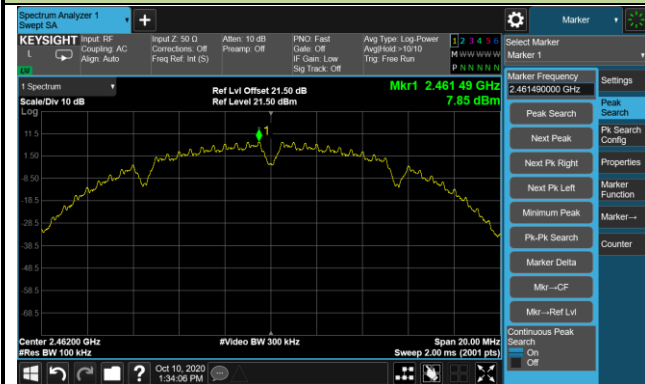

High Band Edge



Spurious Emission

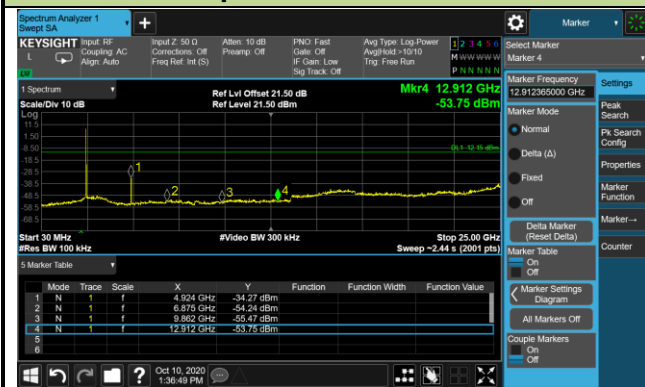

802.11g Out-of-Band Emissions

Channel 01 (2412MHz)

100kHz PSD Reference Level

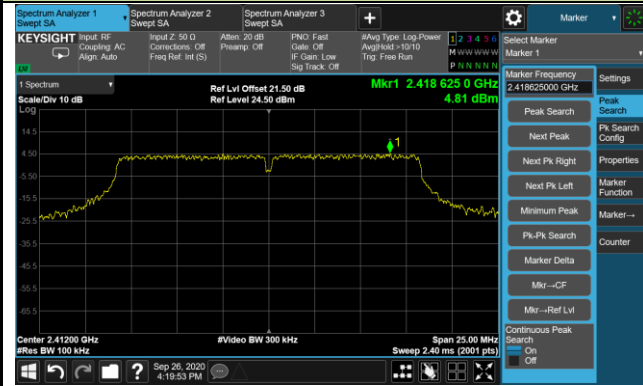

Low Band Edge

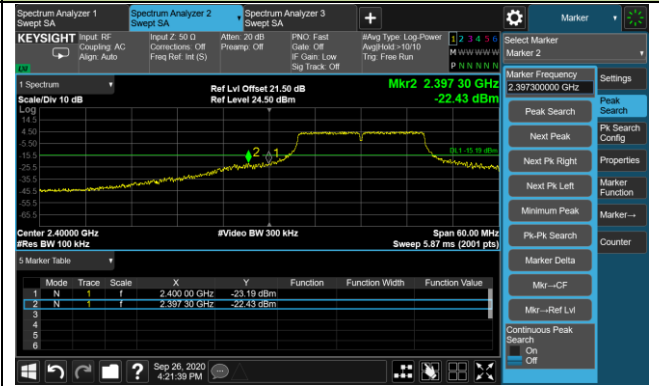

Spurious Emission



Channel 06 (2437MHz)

100kHz PSD Reference Level

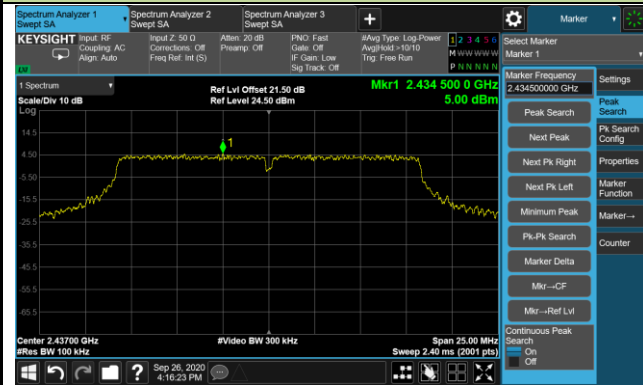

Spurious Emission



802.11g Out-of-Band Emissions Channel 11 (2462MHz)

100kHz PSD Reference Level

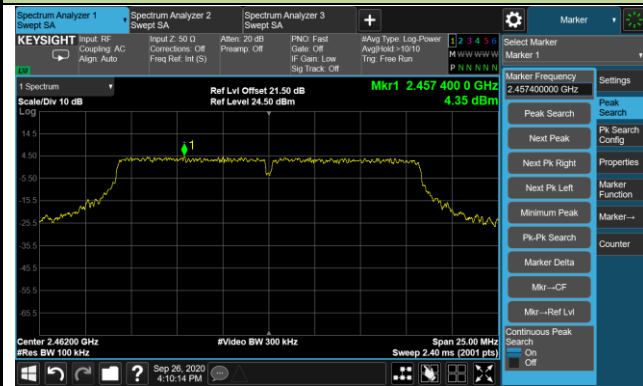

High Band Edge

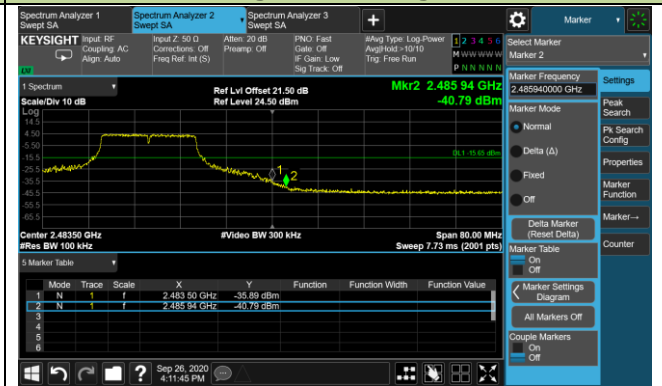

Spurious Emission



802.11n-HT20 Out-of-Band Emissions

Channel 01 (2412MHz)

100kHz PSD Reference Level

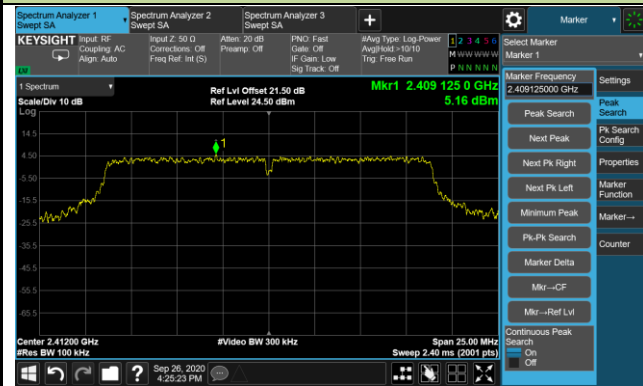

Low Band Edge

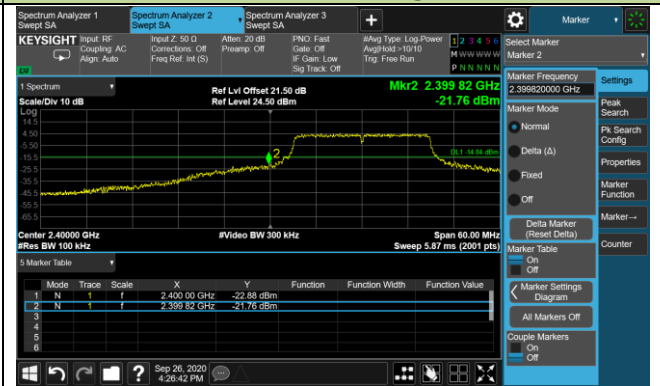

Spurious Emission

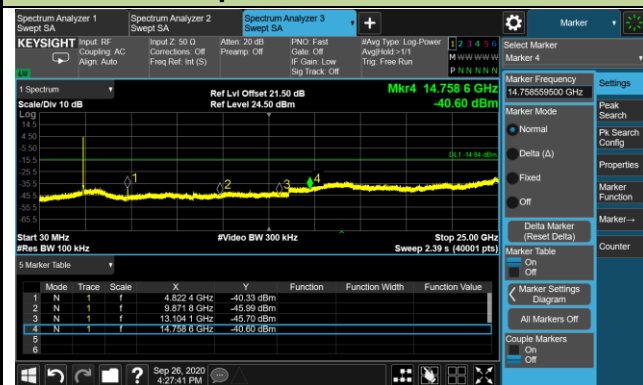

Channel 06 (2437MHz)

100kHz PSD Reference Level



Spurious Emission



802.11n-HT20 Out-of-Band Emissions Channel 11 (2462MHz)

100kHz PSD Reference Level

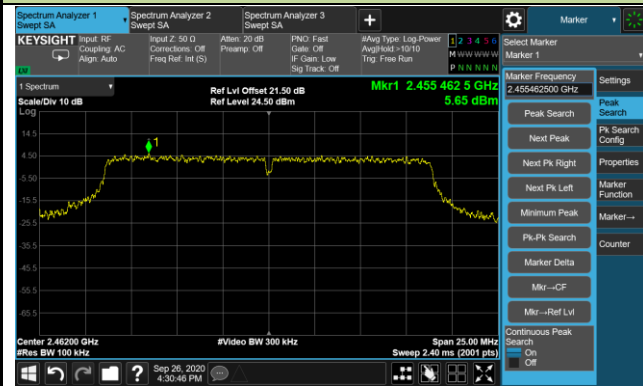

High Band Edge

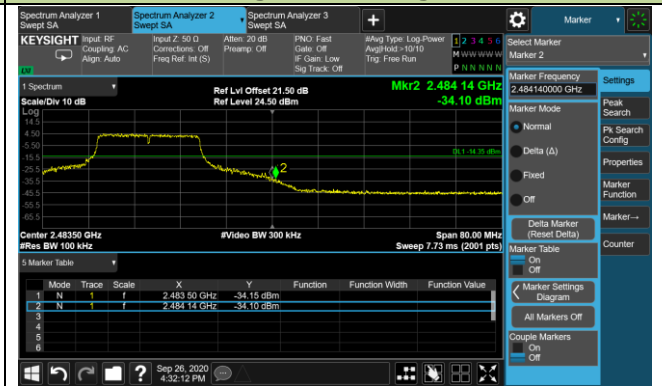

Spurious Emission



802.11n-HT40 Out-of-Band Emissions

Channel 03 (2422MHz)

100kHz PSD Reference Level

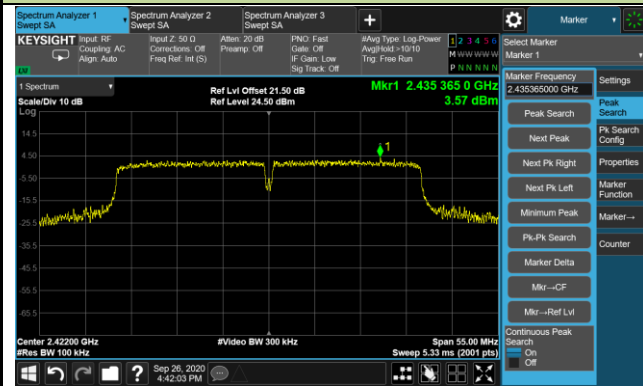

Low Band Edge

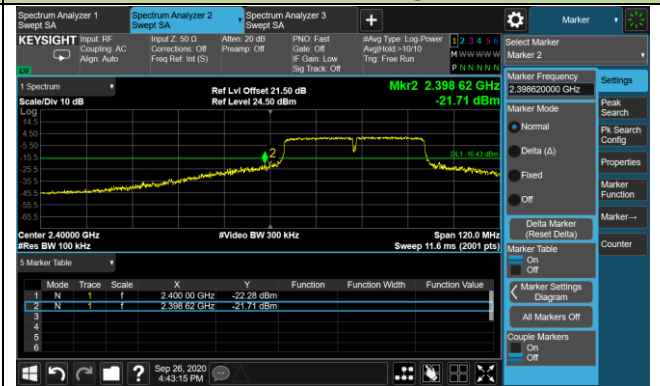

Spurious Emission

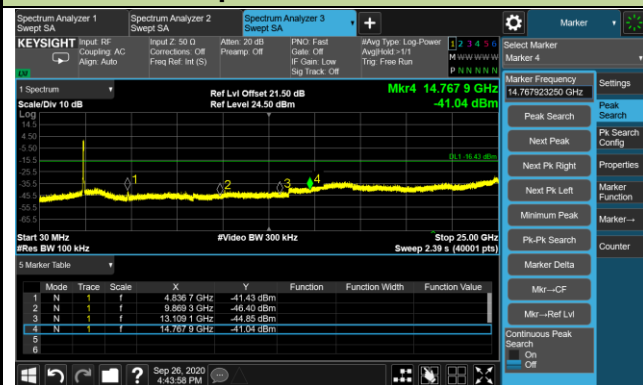

Channel 06 (2437MHz)

100kHz PSD Reference Level

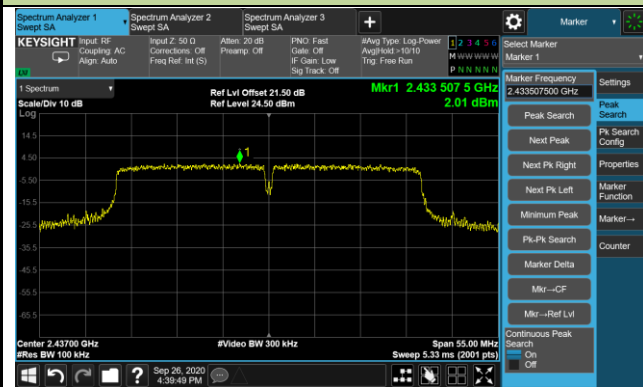

Spurious Emission



802.11n-HT40 Out-of-Band Emissions Channel 09 (2452MHz)

100kHz PSD Reference Level

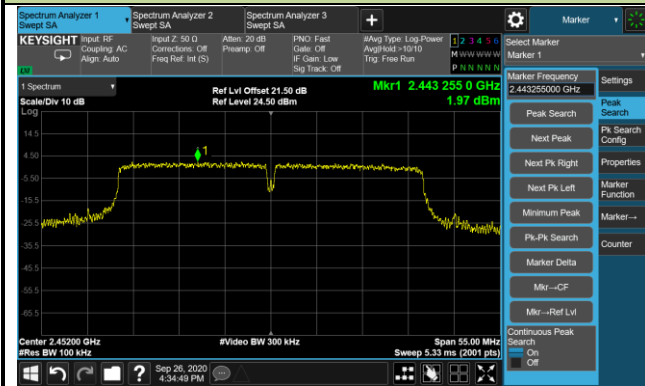

High Band Edge

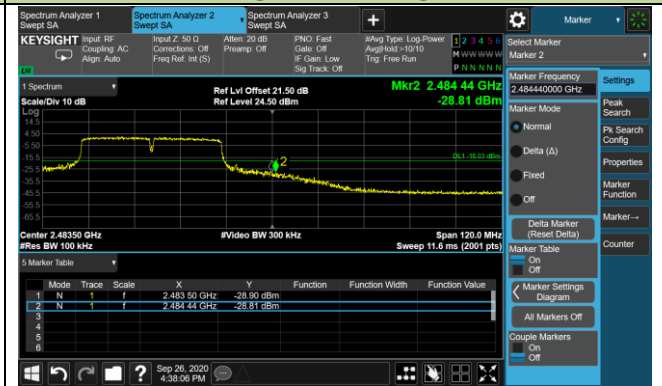

Spurious Emission

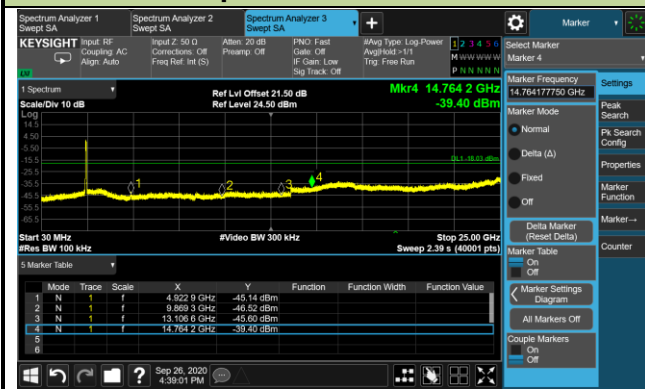

6.6. Radiated Spurious Emission Measurement

6.6.1. Test Limit

All out of band emissions appearing in a restricted band as specified in Section 15.205 of the Title 47 CFR must not exceed the limits shown in Table per Section 15.209.

FCC Part 15 Subpart C Paragraph 15.209		
Frequency [MHz]	Field Strength [uV/m]	Measured Distance [Meters]
0.009 - 0.490	2400/F (kHz)	300
0.490 - 1.705	24000/F (kHz)	30
1.705 - 30	30	30
30 - 88	100	3
88 - 216	150	3
216 - 960	200	3
Above 960	500	3

Except where otherwise indicated in the applicable RSS, radiated emissions shall comply with the field strength limits shown in below table. Additionally, the level of any transmitter unwanted emission shall not exceed the level of the transmitter's fundamental emission.

RSS Gen 8.9 Transmitter emission limits		
General field strength limits at frequencies above 30 MHz		
Frequency [MHz]	Field Strength [uV/m]	Measured Distance [Meters]
30 - 38	100	3
88 - 216	150	3
216 - 960	200	3
Above 960	500	3
RSS Gen 8.9 Transmitter emission limits		
General field strength limits at frequencies below 30 MHz		
Frequency [MHz]	Field Strength [uV/m]	Measured Distance [Meters]
9 – 490 KHz ^{Note 1}	6.37/F (F in kHz)	300
490 -1705 kHz	63.7/F (F in kHz)	30
1.705 -30 MHz	0.08	30

Note 1: The emission limits for the ranges 9-90 kHz and 110-490 kHz are based on measurements employing a linear average detector.

6.6.2. Test Procedure Used

ANSI C63.10 - Section 6.3 (General Requirements)

ANSI C63.10 - Section 6.4 (Standard test method below 30MHz)

ANSI C63.10 - Section 6.5 (Standard test method above 30MHz to 1GHz)

ANSI C63.10 - Section 6.6 (Standard test method above 1GHz)

6.6.3. Test Setting

Table 1 - RBW as a function of frequency

Frequency	RBW
9 ~ 150 kHz	200 ~ 300 Hz
0.15 ~ 30 MHz	9 ~ 10 kHz
30 ~ 1000 MHz	100 ~ 120 kHz
> 1000MHz	1MHz

Quasi-Peak Measurements below 1GHz

1. Analyzer center frequency was set to the frequency of the radiated spurious emission of interest
2. Span was set greater than 1MHz
3. RBW = as specified in Table 1
4. Detector = CISPR quasi-peak
5. Sweep time = auto couple
6. Trace was allowed to stabilize

Peak Measurements above 1GHz

1. Analyzer center frequency was set to the frequency of the radiated spurious emission of interest
2. RBW = 1MHz
3. VBW = 3MHz
4. Detector = peak
5. Sweep time = auto couple

6. Trace mode = max hold

7. Trace was allowed to stabilize

Average Measurements above 1GHz (Method VB)

1. Analyzer center frequency was set to the frequency of the radiated spurious emission of interest

2. RBW = 1MHz

3. VBW; If the EUT is configured to transmit with duty cycle $\geq 98\%$, set VBW = 10 Hz.

If the EUT duty cycle is $< 98\%$, set VBW $\geq 1/T$. T is the minimum transmission duration.

4. Detector = Peak

5. Sweep time = auto

6. Trace mode = max hold

7. Trace was allowed to stabilize

6.6.4. Test Setup

Below 1GHz Test Setup:

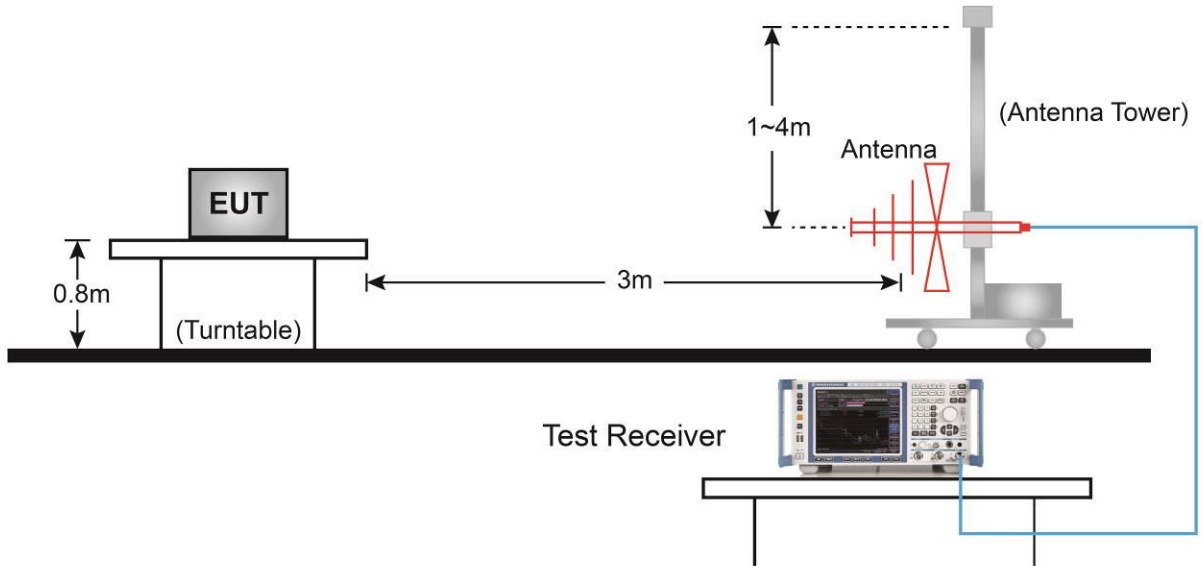

Above 1GHz Test Setup:

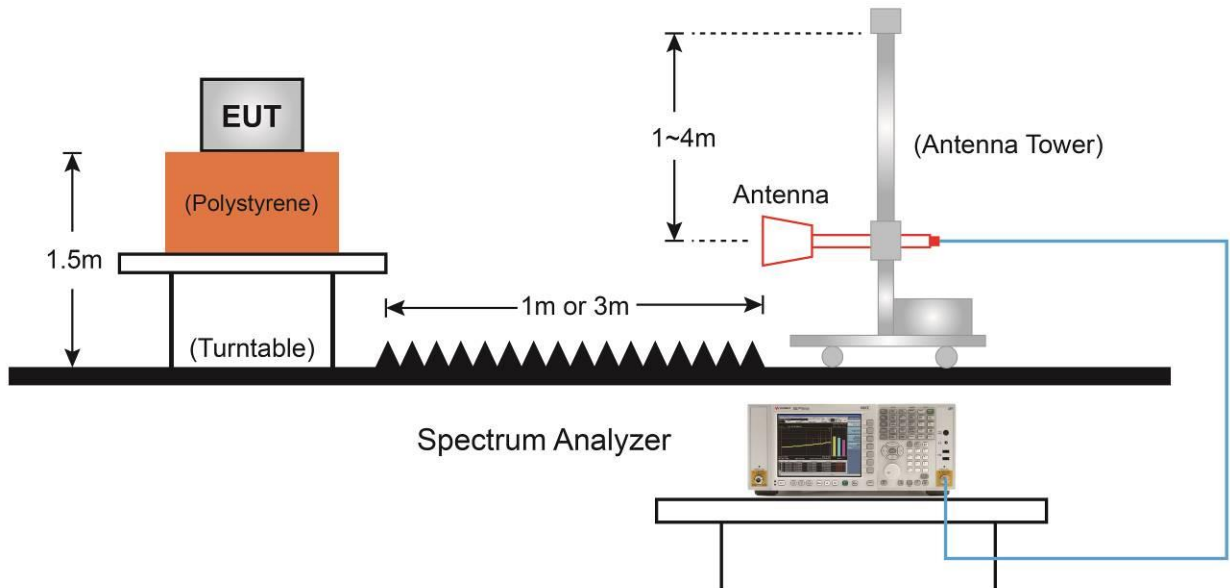

6.6.5. Test Result

Product	Robotic Vacuum Cleaner	Test Engineer	Allen Zou
Test Site	SIP-AC2	Test Date	2020/09/27
Test Mode:	802.11b	Test Channel:	01
Remark:	1. Average measurement was not performed if peak level lower than average limit. 2. Other frequency was 20dB below limit line within 1-18GHz, there is not show in the report.		

Mark	Frequency (MHz)	Reading Level (dBμV)	Factor (dB)	Measure Level (dBμV/m)	Limit (dBμV/m)	Margin (dB)	Detector	Polarization
	4646.5	52.8	-13.8	39.0	74.0	-35.0	Peak	Horizontal
	4825.0	66.5	-13.5	53.0	74.0	-21.0	Peak	Horizontal
*	6516.5	50.9	-8.8	42.1	74.0	-31.9	Peak	Horizontal
*	7230.5	51.8	-6.6	45.2	74.0	-28.8	Peak	Horizontal
	4825.0	66.2	-13.5	52.7	74.0	-21.3	Peak	Vertical
	5114.0	51.2	-12.5	38.7	74.0	-35.3	Peak	Vertical
*	6890.5	51.1	-8.0	43.1	74.0	-30.9	Peak	Vertical
*	7239.0	53.9	-6.6	47.3	74.0	-26.7	Peak	Vertical

Note 1: "*" means test frequency didn't fall into restricted band.

Note 2: Measure Level (dBμV/m) = Reading Level (dBμV) + Factor (dB)

Factor (dB) = Cable Loss (dB) + Antenna Factor (dB/m) - Pre_Amplifier Gain (dB)

Product	Robotic Vacuum Cleaner	Test Engineer	Allen Zou
Test Site	SIP-AC2	Test Date	2020/09/27
Test Mode:	802.11b	Test Channel:	06
Remark:	1. Average measurement was not performed if peak level lower than average limit. 2. Other frequency was 20dB below limit line within 1-18GHz, there is not show in the report.		

Mark	Frequency (MHz)	Reading Level (dB μ V)	Factor (dB)	Measure Level (dB μ V/m)	Limit (dB μ V/m)	Margin (dB)	Detector	Polarization
	4621.0	53.4	-14.0	39.4	74	-34.6	Peak	Horizontal
	4876.0	66.3	-13.4	52.9	74	-21.1	Peak	Horizontal
*	6567.5	50.9	-8.8	42.1	74	-31.9	Peak	Horizontal
*	7111.5	50.2	-6.8	43.4	74	-30.6	Peak	Horizontal
	4621.0	52.7	-14.0	38.7	74	-35.3	Peak	Vertical
	4876.0	67.2	-13.4	53.8	74	-20.2	Peak	Vertical
*	6465.5	51.1	-9.1	42.0	74	-32.0	Peak	Vertical
*	7035.0	50.1	-6.9	43.2	74	-30.8	Peak	Vertical

Note 1: "*" means test frequency didn't fall into restricted band.

Note 2: Measure Level (dB μ V/m) = Reading Level (dB μ V) + Factor (dB)

Factor (dB) = Cable Loss (dB) + Antenna Factor (dB/m) - Pre_Amplifier Gain (dB)