

# 石头科技产品包装图纸

模切

标注

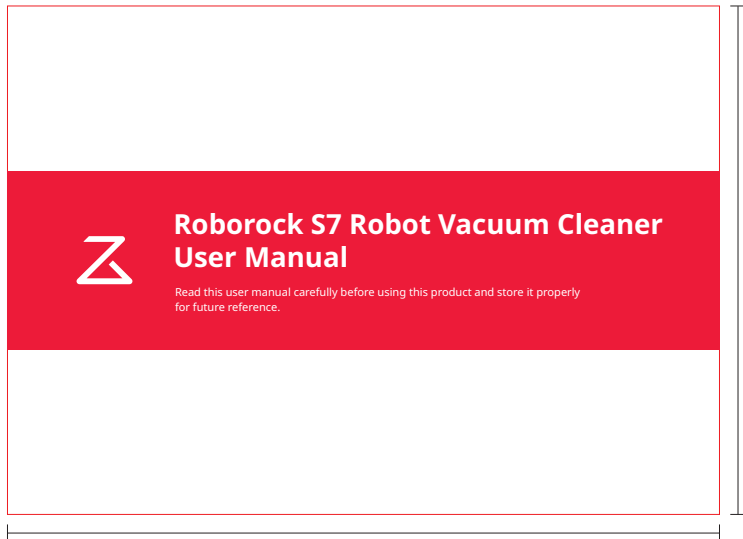

182mm

130mm

图纸  
提供  
单位

北京石头世纪科技股份有限公司

材  
质  
工  
艺  
要  
求

材质：105g 哑粉，骑钉  
成品尺寸：182\*130mm  
页数：44P  
参考色：PANTONE Cool Gray 11 C  
PANTONE 185 C  
尺寸偏差：±0.5mm  
印刷偏位：±1mm

备  
注



项目名称 Tanos\_S 说明书 (FCC)

料号 4.03.0264

版本号 V1.0

设计时间 2020.09.17

设计师 许戈

设计师

比例

1:1

单位

mm

历史  
版本

版本号：  
修改点：  
修改人：

版本号：  
修改点：  
修改人：

版本号：  
修改点：  
修改人：

版本号：  
修改点：  
修改人：

版本号：  
修改点：  
修改人：

版本号：  
修改点：  
修改人：

版本号：  
修改点：  
修改人：

版本号：  
修改点：  
修改人：

版本号：  
修改点：  
修改人：

版本号：  
修改点：  
修改人：



# Roborock S7 Robot Vacuum Cleaner User Manual

Read this user manual carefully before using this product and store it properly for future reference.

# Safety Information

## IMPORTANT SAFETY INSTRUCTIONS

When using an electrical appliance, basic precautions should always be followed, including the following: READ ALL INSTRUCTIONS BEFORE USING (THIS APPLIANCE), Failure to follow the warnings and instructions may result in electric shock, fire and/or serious injury.

### WARNING

To reduce the risk of fire, electric shock, or injury:

- Do not use outdoors or on wet surfaces.
- Do not allow to be used as a toy. Close attention is necessary when used by or near children, pets or plants.
- Please clean up pet waste manually before automatic cleaning.
- Use only as described in this manual. Use only manufacturer's recommended attachments.
- Do not use with damaged cord or plug. If appliance is not working as it should, has been dropped, damaged, left outdoors, or dropped into water, return it to a service center.
- Do not pull or carry by cord, use cord as a handle, close a door on cord, or pull cord around sharp edges or corners.
- Do not run appliance over cord. Keep cord away from heated surfaces.
- Do not unplug by pulling on cord. To unplug, grasp the plug, not the cord.
- Do not handle charger, including charger plug, and charger terminals with wet hands.
- Do not put any object into openings. Do not use with any opening blocked; keep free of dust, lint, hair, and anything that may reduce air flow.
- Keep hair, loose clothing, fingers, and all parts of body away from openings and moving parts.
- Do not use to pick up flammable or combustible liquids, such as gasoline, or use in areas where they may be present.
- Do not pick up anything that is burning or smoking, such as cigarettes, matches, or hot ashes.
- Do not use without dust bag.
- Prevent unintentional starting. Ensure the switch is in the off-position before connecting to battery pack, picking up or carrying the appliance. Carrying the appliance with your finger on the switch or energizing appliance that have the switch on invites accidents.

# Safety Information

- For use only with roborock CDZ11RR or CDZ12RR charger. Recharge only with the charger specified by the manufacturer. A charger that is suitable for one type of battery pack may create a risk of fire when used with another battery pack.
- Use appliances only with specifically designated battery packs. Use of any other battery packs may create a risk of injury and fire.
- Turn off the appliance before making any adjustments, changing accessories, or storing appliance. Such preventive safety measures reduce the risk of starting the appliance accidentally.
- When battery pack is not in use, keep it away from other metal objects, like paper clips, coins, keys, nails, screws or other small metal objects, that can make a connection from one terminal to another. Shorting the battery terminals together may cause burns or a fire.
- Under abusive conditions, liquid may be ejected from the battery; avoid contact. If contact accidentally occurs, flush with water. If liquid contacts eyes, additionally seek medical help. Liquid ejected from the battery may cause irritation or burns.
- Do not use a battery pack or appliance that is damaged or modified. Damaged or modified batteries may exhibit unpredictable behavior resulting in fire, explosion or risk of injury.
- Do not expose a battery pack or appliance to fire or excessive temperature. Exposure to fire or temperature above 130°C may cause explosion.
- Follow all charging instructions and do not charge the battery pack or appliance outside of the temperature range specified in the instructions. Charging improperly or at temperatures outside of the specified range may damage the battery and increase the risk of fire.
- Have servicing performed by a qualified repair person using only identical replacement parts. This will ensure that the safety of the product is maintained.
- Do not modify or attempt to repair the appliance or the battery pack except as indicated in the instructions for use and care. Place the cords from other appliances out of the area to be cleaned.
- Do not operate the vacuum in a room where an infant or child is sleeping.
- Do not operate the vacuum in an area where there are lit candles or fragile objects on the floor to be cleaned.
- Do not operate the vacuum in a room that has lit candles on furniture that the vacuum may accidentally hit or bump into.
- Do not allow children to sit on the vacuum.
- Do not use the vacuum cleaner on a wet surface.

# Safety Information

- Risk Of Injury. Brush May Start Unexpectedly. Disconnect the main Brush Before Cleaning or Servicing.
- Do not use the product when the temperature is higher than 40°C or lower than 4°C, or there is any liquid or sticky substance on the floor.

## SAVE THESE INSTRUCTIONS

Household use only.

## IMPORTANTES MESURES DE S CURIT

L'utilisation d'un appareil électrique demande certaines précautions:

LIRE TOUTES LES INSTRUCTIONS AVANT DE FAIRE FONCTIONNER (CETAPPAREIL), Le non-respect des mises en garde et des instructions peut causer des chocs électriques, des incendies et/ou des blessures graves.

## AVERTISSEMENT

- Pour réduire les risques d'incendie, de choc électrique ou de blessure:
- Ne pas exposer à la pluie, Ranger à l'intérieur.
- Ne pas permettre aux enfants de jouer avec l'appareil. Une attention particulière est nécessaire lorsque l'appareil est utilisé par des enfants ou à proximité de ces derniers.
- N'utiliser que conformément à cette notice avec les accessoires recommandés par le fabricant.
- Ne pas utiliser si le cordon ou la fiche est endommagé. Retourner l'appareil à un atelier de réparation s'il ne fonctionne pas bien, s'il est tombé ou s'il a été endommagé, oublié à l'extérieur ou immergé.
- Ne pas tirer soulever ni trainer l'appareil par le cordon. Ne pas utiliser le cordon comme une poignée, le coincer dans l'embrasure d'une porte ou l'appuyer contre des arêtes vives ou des coins. Ne pas faire rouler l'appareil sur le cordon.
- Garder le cordon à l'écart des surfaces chaudes. Ne pas débrancher en tyrant sur le cordon. Tirer plutt la fiche. Ne pas manipuler le chargeur, y compris la prise du chargeur, et les bornes du chargeur avec les mains mouillées.

# Safety Information

- N'insérer aucun objet dans les ouvertures. Ne pas utiliser l'appareil lorsqu'une ouverture est bloquée. S'assurer que de la poussière, de la peluche, des cheveux ou d'autres matières ne réduisent pas le débit d'air. Maintenir les cheveux, les vêtements amples, les doigts et toutes les parties du corps à l'écart des ouvertures et des pièces mobiles.
- User de prudence lors du nettoyage des escaliers.
- Ne pas aspirer des liquides inflammables ou combustibles, comme de l'essence, et ne pas faire fonctionner dans des endroits où peuvent se trouver de tels liquides.
- Ne pas aspirer de matières en combustion ou qui dégagent de la fumée, comme des cigarettes, des allumettes ou des cendres chaudes.
- Ne pas utiliser l'appareil si le sac à poussière ou le filtre n'est pas en place.
- Éviter une mise en marche accidentelle. S'assurer que l'interrupteur est à la position arrêt avant de raccorder la batterie, de lever ou de déplacer l'appareil. Transporter l'appareil en gardant un doigt sur l'interrupteur, ou mettre sous tension un appareil dont l'interrupteur est à la position marche peut causer un accident.
- Pour emploi seulement avec roborock CDZ11RR or CDZ12RR chargeur. Recharger uniquement avec le chargeur prescrit par le fabricant. Un chargeur convenant à un type de batterie peut présenter un risque d'incendie lorsqu'il est utilisé avec une autre batterie.
- Retirer la batterie de l'appareil avant d'effectuer des réglages, changer les accessoires ou ranger l'appareil. Ces mesures de sécurité ont pour but d'éviter une mise en marche accidentelle de l'appareil.
- Utiliser uniquement les batteries recommandées pour l'appareil. L'utilisation d'autres types de batteries peut présenter un risque de blessure ou d'incendie.
- Lorsque l'appareil n'est pas utilisé, tenir la batterie loin d'objets métalliques comme des trombones, des pièces de monnaie, des clés, des clous, des vis ou autres petits objets qui pourraient établir une liaison entre les bornes. Un court-circuit des bornes des batteries peut causer des brûlures ou un incendie.
- En condition d'usage abusif, du liquide peut s'échapper de la batterie ; éviter tout contact avec ce liquide.
- En cas de contact accidentel, rincer abondamment avec de l'eau. En cas de contact avec les yeux, consulter également un médecin. Le liquide projeté peut causer des irritations ou des brûlures.
- Ne pas utiliser une batterie ou un appareil endommagé ou qui a été modifié. Des batteries endommagées ou modifiées peuvent avoir un comportement imprévisible pouvant causer un incendie, une explosion ou un risque de blessure.

# Safety Information

- Ne pas exposer une batterie ou un appareil à la flamme ou à des températures excessives. L'exposition à une flamme ou à des températures supérieures à 130 °C peut causer une explosion.
- Respecter toutes les instructions de chargement et ne pas charger la batterie ou l'appareil à des températures qui ne sont pas incluses dans la gamme de températures indiquées dans la notice d'instructions. Un chargement mal effectué.
- Confier les réparations à une personne qualifiée qui utilisera uniquement des pièces de remplacement identiques. Cette façon de faire garantira la sécurité du produit.
- Ne pas modifier ni tenter de réparer l'appareil ou la batterie sauf comme il est indiqué dans les instructions d'utilisation et d'entretien.
- Éloigner les cordons d'autres appareils de la zone à nettoyer.
- Ne pas utiliser l'aspirateur dans une pièce où un nourrisson ou un enfant dort.
- Ne pas utiliser l'aspirateur dans un endroit où il ya des bougies allumées ou des objets fragiles sur le plancher à nettoyer.
- Ne pas utiliser l'aspirateur dans une pièce où il ya des bougies allumées sur les meubles que l'aspirateur peut heurter ou se cogner accidentellement.
- Ne pas laisser les enfants s'asseoir sur l'aspirateur.
- Ne pas utiliser l'aspirateur sur une surface mouillée. Risque de blessures. La brosse motorisée peut se mettre en marche d'une manière imprévue.
- Déconnecter la brosse principale avant le nettoyage ou le service.

## CONSERVER CES INSTRUCTIONS

Usage Domestique seulement.

## Laser Safety

Class 1 laser product, Complies with FDA 21 CFR 1040.10 and 1040.11 except for conformance with IEC 60825-1 Ed. 3., as described in Laser Notice 56, dated May 8, 2019.

# FCC IC Statement

<b>Compliance Information</b>	
Product Name	Robotic Vacuum Cleaner with Dock Charger
Produce Model	Robotic Vacuum Cleaner Model: roborock S7 Dock Charger Model: CDZ11RR or CDZ12RR
Compliance Statement	This device complies with part 15 of the FCC Rules. This device contains licence-exempt transmitter(s)/receiver(s) that comply with Innovation, Science and Economic Development Canada's licence-exempt RSS(s). Operation is subject to the following two conditions: (1) This device may not cause harmful interference, and (2) this device must accept any interference received, including interference that may cause undesired operation.
<b>Correspondence of the responsible party in USA</b>	
Company	Roborock Technology Co.
Address	108 West 13th Street, Wilmington, Delaware 19801.
Email	support@roborock.com

## Warning

Any changes or modifications to this unit not expressly approved by the party responsible for compliance could void the user's authority to operate the equipment.

Le présent appareil est conforme aux CNR d'Industrie Canada applicables aux appareils radio exempts de licence.



# FCC IC Statement

L'exploitation est autorisée aux deux conditions suivantes :

- (1) l'appareil ne doit pas produire de brouillage, et
- (2) l'utilisateur de l'appareil doit accepter tout brouillage radioélectrique subi, même si le brouillage est susceptible d'en compromettre le fonctionnement.

This equipment has been tested and found to comply with the limits for a Class B digital device, pursuant to part 15 of the FCC Rules. These limits are designed to provide reasonable protection against harmful interference in a residential installation. This equipment generates uses and can radiate radio frequency energy and, if not installed and used in accordance with the instructions, may cause harmful interference to radio communications. However, there is no guarantee that interference will not occur in a particular installation. If this equipment does cause harmful interference to radio or television reception, which can be determined by turning the equipment off and on, the user is encouraged to try to correct the interference by one or more of the following measures:

- Reorient or relocate the receiving antenna.
- Increase the separation between the equipment and receiver.
- Connect the equipment into an outlet on a circuit different from that to which the receiver is connected.
- Consult the dealer or an experienced radio/TV technician for help.

# MPE Requirements

To satisfy FCC / IC RF exposure requirements, a separation distance of 20 cm or more should be maintained between the antenna of this device and persons during device operation. To ensure compliance, operations at closer than this distance is not recommended.

L'antenne installée doit être située de façon à ce que la population ne puisse être exposée à une distance de moins de 20 cm. Installer l'antenne de façon à ce que le personnel ne puisse approcher à 20 cm ou moins de la position centrale de l'antenne. La FCC des États-Unis stipule que cet appareil doit être en tout temps éloigné d'au moins 20 cm des personnes pendant son fonctionnement.

CAN ICES-3 (B)/NMB-3(B)

# Battery and Charging

- Please keep the dock charger away from heat (such as heating plates).
- Do not wipe or clean the chargers shrapnel with a piece of wet cloth or wet hands.
- Please make sure the cleaner is powered off in shipment and original packaging is advised.
- If left unused for a long period, please store the cleaner in a cool and dry place after having it fully charged and switched off, charge it at least every three months to avoid the battery being over discharged.
- Please do not use the product when the temperature is higher than 40°C or lower than 4°C , or there is any liquid or sticky substance on the floor.

Battery pack charging temperature		4°C ~ 40°C	@Max Charging Current:0.5C
Battery pack using temperature		4°C ~ 40°C	@Max Discharge Current:0.5C
Battery pack storage temperature	Storage(1month)	-20°C ~ 60°C @Less than 70% RH	If the battery pack store at 25°C over the 3 months period, it should be recharged.
	Long Storage(3months)	-20°C ~ 45°C @Less than 70% RH	
	Long Storage(1year)	-20°C ~ 20°C @Less than 70% RH	

# Product overview

## Robot

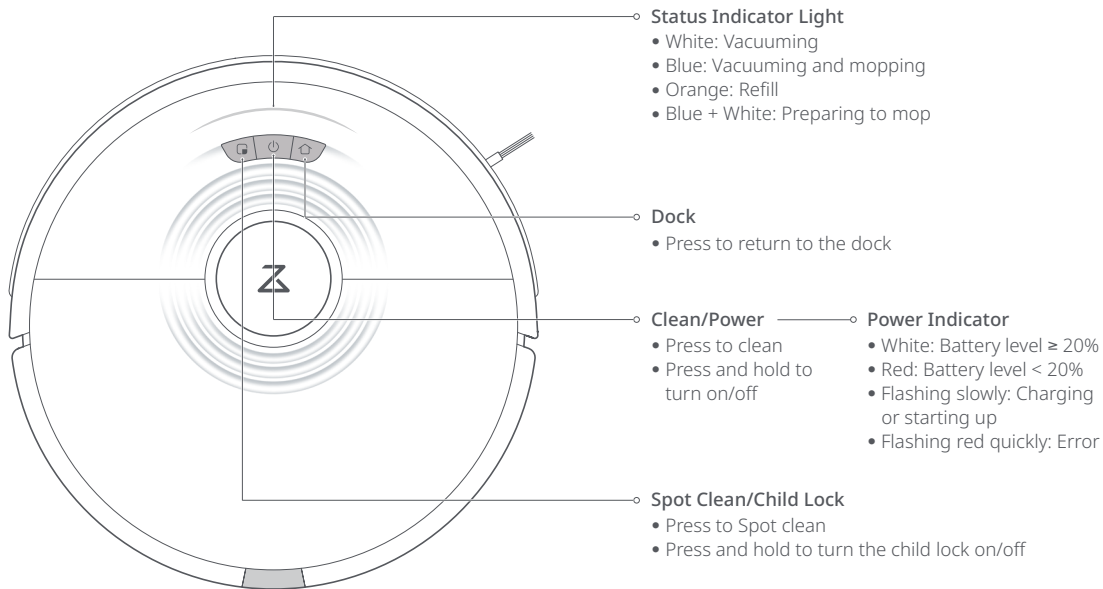

**Note:** Press any button to pause the robot when cleaning or returning to the dock.

# Product overview

## Parts List

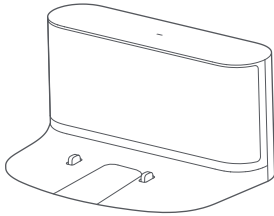

Charging Dock

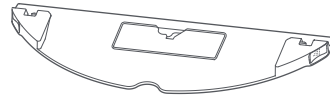

VibraRise Mop Cloth Bracket

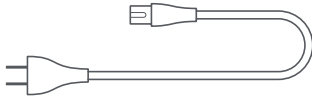

Power Cable



Mop Cloth

# Product overview

## Robot

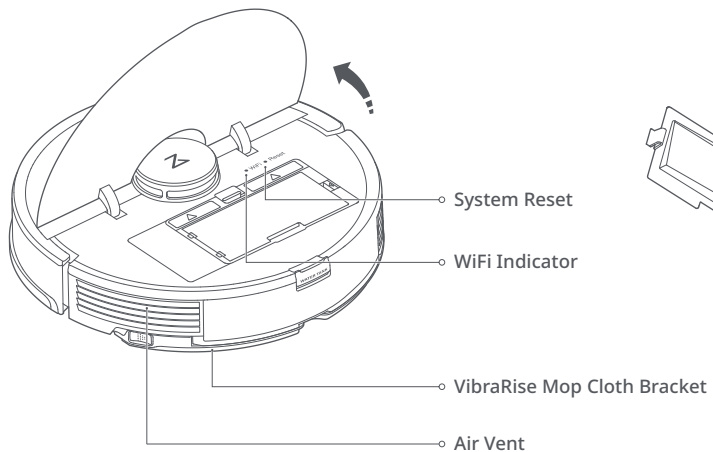

## Dustbin

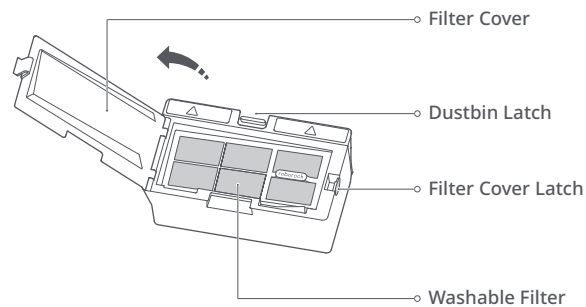

# Product overview

## Sensors

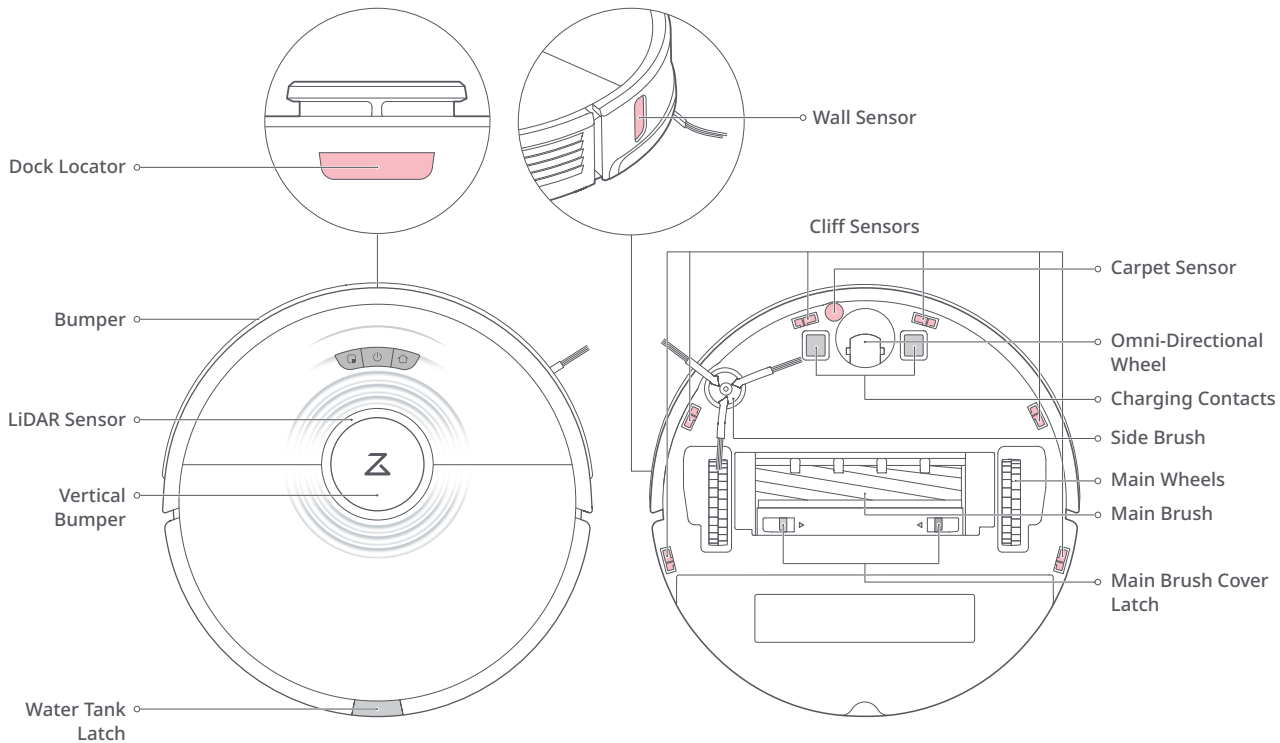

# Product overview

## VibraRise Module

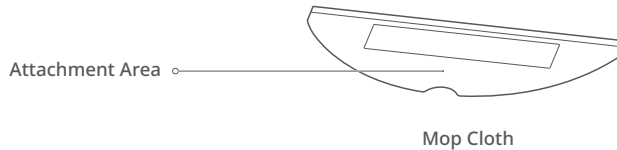
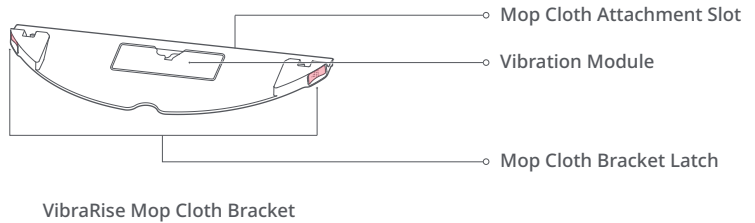
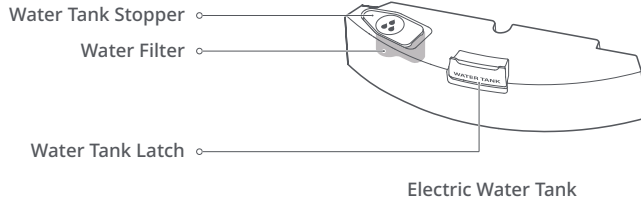

# Product overview

## Charging Dock

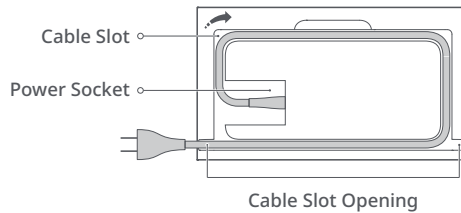
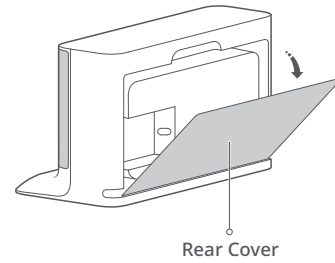
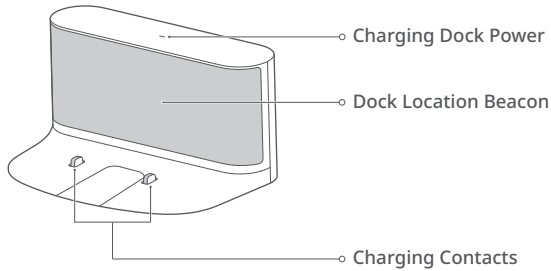

**Note:** Cables can exit from the left or right openings.



# Installation

## Important

1. Tidy cables and loose items from the ground and move any unstable, fragile, precious, or dangerous objects to prevent personal injury or property damage due to things becoming tangled in, struck by, or knocked over by the robot.

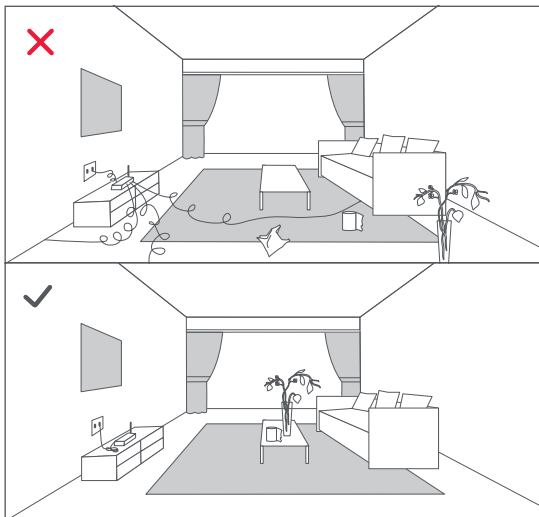

### Note:

- When using the robot for the first time, follow it throughout its whole cleaning route and watch for major obstacles. The robot will be able to clean by itself in future uses.
- If some areas do not need to be cleaned or when some objects that may cause the robot to become stuck, use in-app No-Go Zones or Invisible Walls to prevent access.

2. If using this robot in a raised area, always use a secure physical barrier to prevent accidental falls that may result in personal injury or property damage.

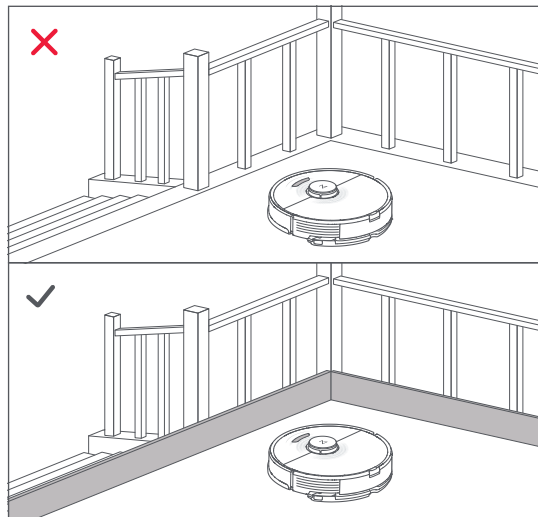

# Installation

## 1 Position the charging dock

Keep the charging dock on a level surface, flat against a wall. Connect the power cable to the charging dock and place any loose wire into the cable slot. To ensure a better mobile app experience, place the charging dock in an area with strong WiFi coverage.

### Note:

- Keep least 0.5m (1.6ft) on each side and 1.5m (4.9ft) in front of the charging dock clear.
- If the power cable hangs vertically, it may be caught by the robot, causing the charging dock to be disconnected.
- The charging dock indicator is lit when the charging dock is powered up, and off when the robot is charging.
- Do not place the charging dock in direct sunlight or block the location beacon, as the robot may not be able to return.

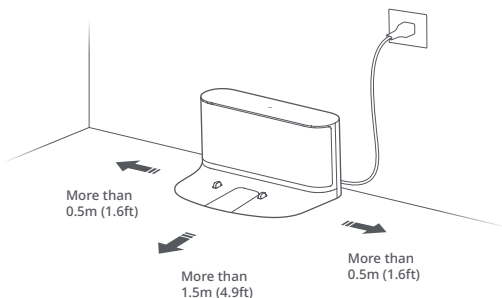

## 2 Power on and charge the robot

Press and hold the  button to power on the robot. When the power light goes on, place it on the dock to charge. To maintain the performance of the high-performance lithium-ion rechargeable battery pack, keep the robot charged.

**Note:** The robot may not turn on when the battery is low. In this case, place the robot directly onto the dock to charge.

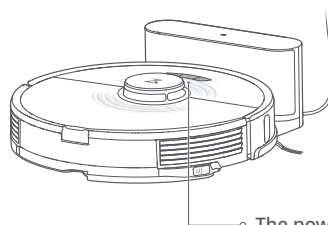

The power indicator color indicates the battery level.

- White: Battery level  $\geq$  20%
- Red: Battery level  $<$  20%

# Installation

## 3 Mopping the floor

**Note:** To prevent excessive buildup of dirt on the mop, floors should be vacuumed at least three times before the first mopping cycle.

### 1. Remove the water tank

Release the water tank latch and slide the tank backward.

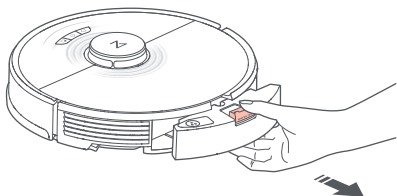

### 2. Fill the water tank

Open the water tank, fill it with water, and close it tightly.

**Note:**

- Fill with water only. Cleaning fluids and/or disinfectants may corrode the water tank.
- Use cold/room temperature water only. Hot water may cause water tank deformation.

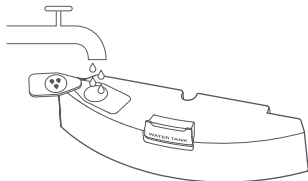

### 3. Reinstall the water tank

Slide the water tank along the grooves until you hear it click in place.

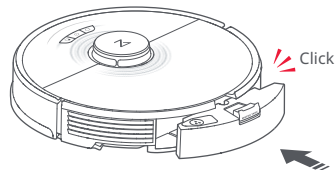

### 4. Install the mop cloth

Wet the mop cloth and squeeze to remove excess water. Slide it along the attachment slot and stick it firmly in place.

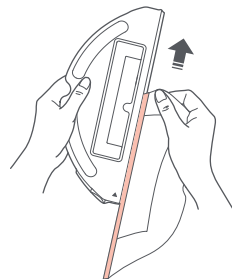

# Installation

## 5. Install the mop cloth bracket

Slide the vibrating mop cloth bracket along the bottom of the water tank until you hear it click in place.

### Note:

- Clean the mop cloth after 60 minutes of mopping to maintain water flow and cleaning quality.
- Only mop in non-carpeted areas.

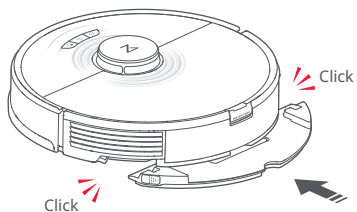

## 6. Remove the mop cloth bracket

After returning to the dock, remove the mop cloth bracket by pressing both side latches and sliding back.

### Note:

- Wash the mop cloth after each use, and regularly empty the water tank of unused water.
- Remove the mop cloth bracket when not mopping. The water tank can be kept in place.

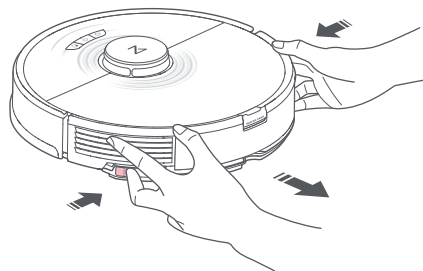

# Installation

## WARNING

Risk of injury do not put your hand into the seam, it may cut your finger.

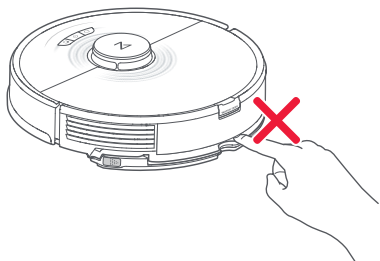

# Connecting to the App

This robot supports both Roborock and Mi Home apps. Choose the one that best meets your needs.

## 1 Downloading the app

1. Search for "Roborock" in the App Store or Google Play or scan the QR code to download and install the app.





2. Search for "Mi Home" in the App Store or Google Play or scan the QR code to download and install the app.



# Connecting to the App

## 2 Reset WiFi

1. Open the upper cover and find the WiFi indicator.
2. Press and hold the  and  buttons until you hear the "Resetting WiFi" voice alert. The reset is complete when the WiFi indicator flashes slowly. The robot will then wait for a connection.

**Note:** If you cannot connect to the robot due to your router configuration, a forgotten password, or any other reason, reset the WiFi and add your robot as a new device.

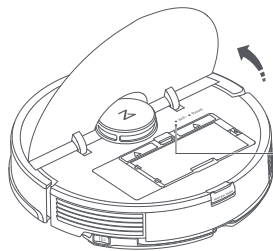

### WiFi indicator light

- Off: WiFi disabled
- Flashing slowly: Waiting for connection
- Flashing quickly: Connecting
- Steady: WiFi connected

## 3 Add device



On the app homepage, tap "+" in the top right corner and follow the prompts to add a device.

### Note:

- The actual process may vary due to ongoing app updates. Follow the instructions provided in the app.
- Only 2.4GHz WiFi is supported.
- If the robot waits more than 1 hour for a connection, WiFi will be automatically disabled. If you need to reconnect, reset the WiFi before proceeding.

# Instructions

## On/Off

Press and hold the  button to turn on the robot. The power indicator will turn on, and the robot will enter standby mode. Press and hold the  button to turn off the robot and end the current cleaning cycle.

**Note:** The robot cannot be turned off when it is charging.

## Start Cleaning

Press the  button to start cleaning. The robot will plan its route based on its scan of the room. It then splits each room into squares, cleaning the edges of the square first before covering the inside in a zigzag pattern. Afterward, it moves to the next square until every zone in every room has been efficiently covered.

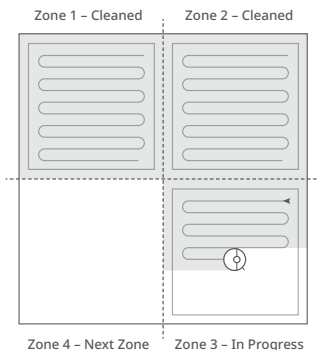

### Note:

- Cleaning cannot start if the battery level is too low. Allow the robot to charge before starting cleanup.
- Before cleaning, tidy cables (including the charging dock power cable) and fragile items from the floor. Loose wires and objects may get caught in the robot, resulting in disconnection or damage to wires and property.
- If cleaning is completed in less than 10 minutes, the area will be cleaned twice.
- If the battery runs low during the clean, the robot will automatically return to the charging dock to top up and continue where it left off.
- If the mop bracket is attached, the robot will lift the mop to clean carpeted areas. You can choose to avoid carpeted areas in the app.

## Mode Setting

Use the app to adjust suction power and water flow when mopping.

# Instructions

## Spot Clean



Press  to start Spot cleaning.

Area: 1.5m (4.9ft) square centered on the robot.

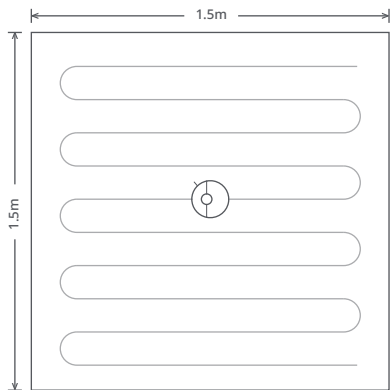
**Note:** After spot cleaning, the robot will return to the starting point and enter Standby mode.



## Pause

During a clean, press any button to pause, press  to continue, or press  to send the robot back to the dock.

**Note:** Placing a paused robot on the charging dock will end the current cleanup.

## Sleep

If the robot is inactive for over 10 minutes, it will enter Sleep mode, and its power indicator will flash slowly. Press any button to wake it up.

**Note:**

- The robot will not enter Sleep mode when charging.
- The robot will automatically shut down if left in Sleep mode for more than 12 hours.

## Do Not Disturb (DND) mode

DND mode is enabled by default from 22:00 to 08:00. It can be disabled or customized in the app. In DND mode, cleaning is stopped, voice prompts are silenced, and the power indicator dims.

## Child Lock

On/Off: Press and hold the  button on the robot or turn the Child Lock on/off in the app. The Child Lock only works when the robot is charging.



# Instructions

## Charging

The robot will return to the charging dock automatically after finishing. If it is paused, press the  button to send it to the charging dock. The power indicator will flash slowly as the robot charges.

**Note:** If the robot cannot find the charging dock, it will return to the most recent starting location. Place the robot on the charging dock manually to recharge.

## Error

If an error occurs, the power indicator flashes red quickly, and a voice alert sounds. See Troubleshooting for solutions.

**Note:**

- The robot will automatically enter Sleep mode if left in an error state for over 10 minutes.
- Placing the robot on the charging dock in an error state will stop the current cleanup.

## System Reset

If the robot does not respond to button presses or cannot be turned off, reset the system. The robot will then restart.

**Note:** After a system reset, cleaning schedules, WiFi, and other settings will be restored to factory settings.

## Restore Factory Settings

If the robot is not functioning after a system reset, turn it on and press the  button. Then press and hold the Reset button until you hear the "Restoring the initial version" voice prompt. The robot will then be restored to factory settings.

## Selective Room Cleaning

The robot will clean the areas selected in the app.

**Note:**

- Map Saving mode must be switched on, and a full clean completed before this function can be used.
- The robot may enter unselected areas during cleaning. Clear obstacles from the ground around the selected rooms as the robot may enter these areas.

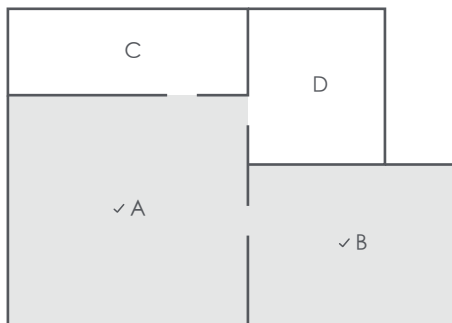

## Zone Cleaning

The robot will clean the Zone(s) drawn in-app.

**Note:** The robot may enter unselected areas during cleaning. Clear obstacles from the ground around the selected rooms as the robot may enter these areas.

# Instructions

## Scheduled Cleaning

Set cleaning schedules, and at the defined times, the robot will clean and return to the dock.

## No-Go Zones, No-Mop Zones, and Invisible Walls

Use No-Go Zones, and Invisible Walls created in-app to prevent access to certain areas and rooms. By default, No-Mop Zones will activate when the mopping module is mounted.

**Note:**

- Map Saving mode must be switched on, and a full clean completed before this function can be used.
- No-Go Zones, No-Mop Zones, and Invisible Walls should only be used to customize the cleaning area. They should not be used to isolate hazards.
- Moving the robot by hand or making significant changes to the environment may cause the loss of No-Go Zones, No-Mop Zones, and Invisible Walls.

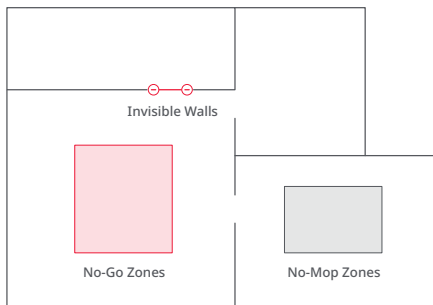

## Firmware Updates

Use the app to update the robot firmware. Update when the robot is on the charging dock and has at least 20% battery power. The power indicator will flash white quickly during the update.

## More App Functions

Real-Time Map View	Carpet Boost
Cleaning History	Maintenance Schedule
Find Robot	Adjust Volume
View Robot Status	Map Management
Firmware Updates	

**Note:** Actual app functions and details may differ slightly due to ongoing development and upgrades.

# Routine Maintenance

To maintain optimum performance, maintain the robot according to the following guidelines:

Part	Maintenance Frequency	Replacement Frequency	Maintenance Method
Omni-Directional Wheel	As required	/	Use a screwdriver or similar tool to pry out the axles. Rinse, allow to dry and press the wheel back in place.
Main Brush	2 weeks	6-12 months	Rotate in the Unlock direction and remove. Extract any entangled dirt then reinstall.
Side Brush	Monthly	3-6 months	Use a screwdriver to unscrew the side brush. Remove any entangled dirt and screw it back in place.
Washable Filter	2 weeks	6-12 months	Remove and rinse, gently tapping to remove any dirt. Air-dry for at least 24h before reuse.
Mop Cloth	After each use	3-6 months	Remove and clean the mop after each use.
Charging Contacts (Robot)	Monthly	/	Wipe clean with a soft dry cloth.
Charging Contacts (Charging Dock)	Monthly	/	Wipe clean with a soft dry cloth.
Dock Locator	Monthly	/	Wipe clean with a soft dry cloth.
Cliff Sensors	Monthly	/	Wipe clean with a soft dry cloth.
Carpet Sensor	Monthly	/	Wipe clean with a soft dry cloth.
Main Wheels	Monthly	/	Wipe clean with a soft dry cloth.

**Note:** Replacement frequency will vary depending on the actual situation. Should abnormal wear and tear occur, replace the relevant part.

# Routine Maintenance

## Main Brush

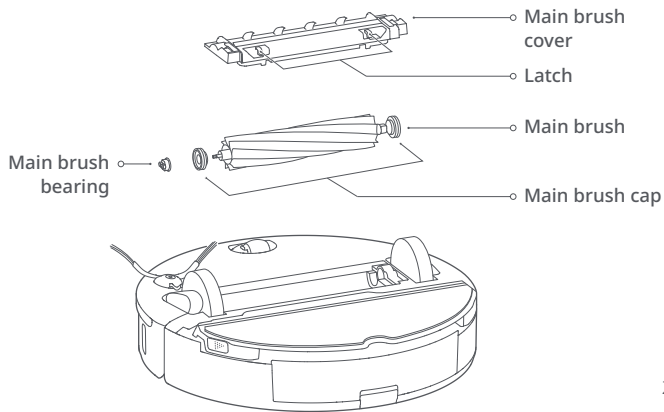

1. Turn the robot over, then unlatch and remove the main brush cover.

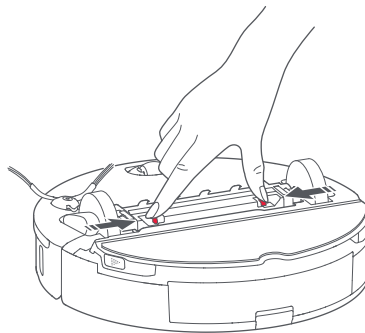

2. Take out the main brush, then remove and clean the bearings.

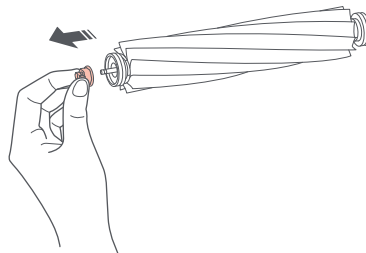

# Routine Maintenance

## Main brush

3. Remove the main brush cap, rotating in the unlock direction. After cleaning, reattach it turning in the lock direction.

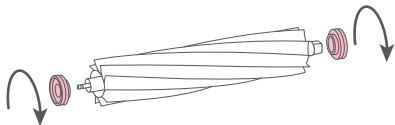

4. After removing the tangled hair or dirt at both ends of the main brush, reinstall it, press on the main brush cover to lock it in place.

**Note:** Use a wet cloth to wipe the main brush. Dry thoroughly before use while avoiding direct exposure to the sun.

## Side Brush

1. Unscrew the side brush and remove any entangled dirt.
2. Reinstall and tighten in place.

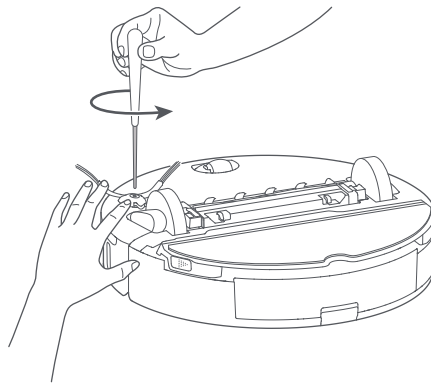

# Routine Maintenance

## Omni-Directional Wheel

1. Use a small screwdriver or similar tool to pry out the axles and remove the wheel.

**Note:** The omni-directional wheel bracket cannot be removed.

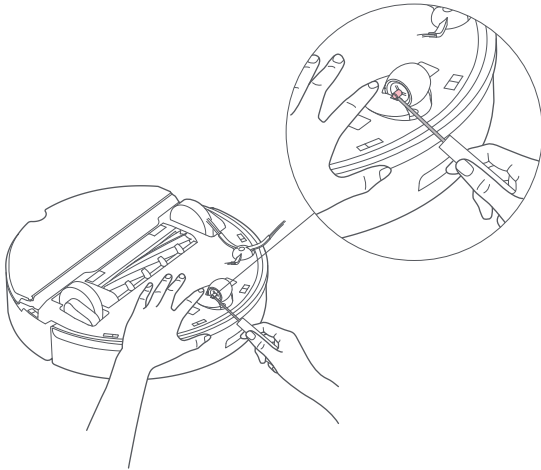

2. Rinse the wheel and axle to remove any hair or dirt.

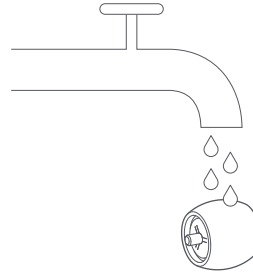

3. Dry and reattach the wheel, pressing it firmly in place.

# Routine Maintenance

## Main Wheels

Use a soft dry cloth to wipe and clean the main wheels.

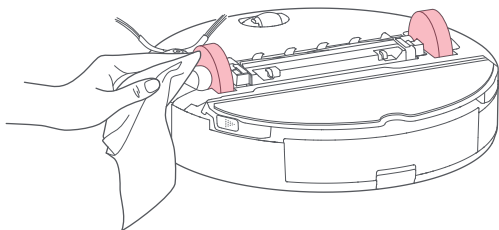

## Dustbin

1. Open the top cover of the robot and remove the dustbin.

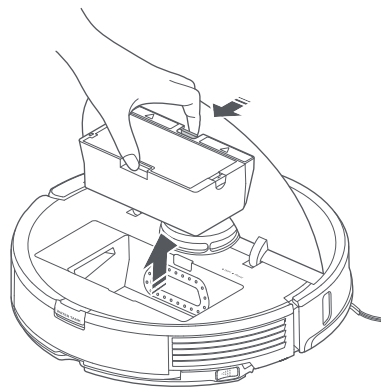

# Routine Maintenance

## Dustbin

2. Open the lid and empty the dustbin.

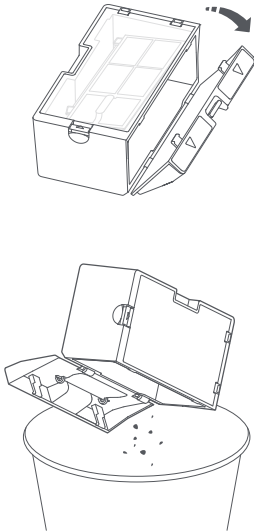

3. Fill it with clean water and close the lid. Gently shake the dustbin, then pour out the dirty water.

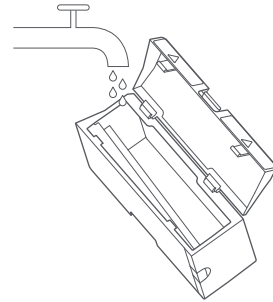

4. Air-dry the dustbin and washable filter.

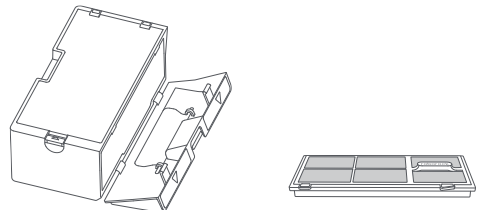



# Routine Maintenance

## Washable Filter

1. Open the filter cover and remove the filter.

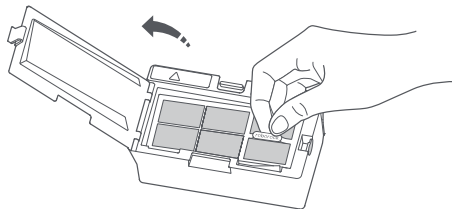

2. Rinse repeatedly and tap the filter frame to remove as much dirt as possible.

**Note:** To avoid damage, do not touch the filter with hands, brushes, or sharp objects.

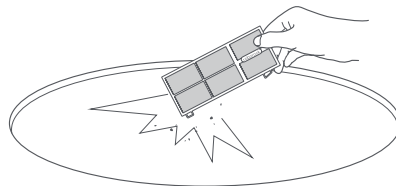
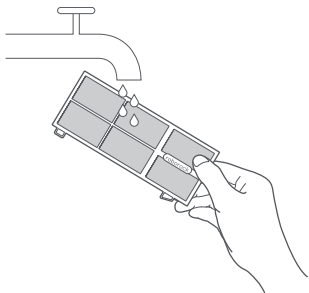

3. Leave the filter to dry thoroughly before reinstalling it.

**Note:** Use an alternate filter if necessary.

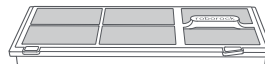

# Routine Maintenance

## Water Tank

1. Open the water tank and fill it with clean water.

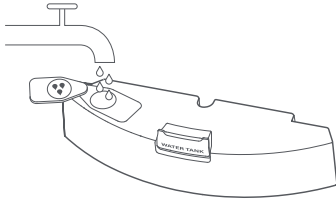

2. Close up the water tank and shake it gently.

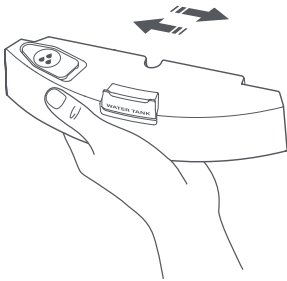

3. Pour out dirty water.

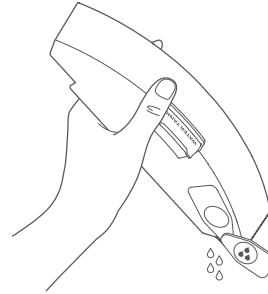

# Routine Maintenance

## Mop cloth

1. Remove the mop cloth from the mop cloth bracket.

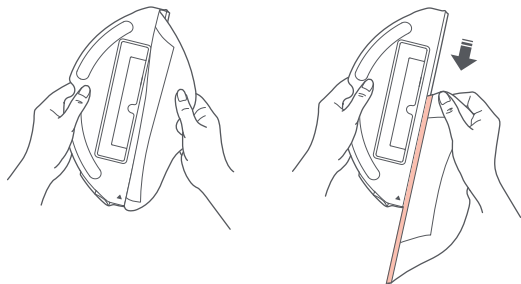

2. Clean the mop cloth and air-dry it.

**Note:** A dirty mop cloth will affect mopping performance. Always start with a clean cloth.

## Robot Sensors

Use a soft dry cloth to wipe and clean all sensors, including:

1. The dock locator in the front
2. The wall sensor on the right.
3. The carpet sensor on the bottom.
4. The six cliff sensors on the bottom.

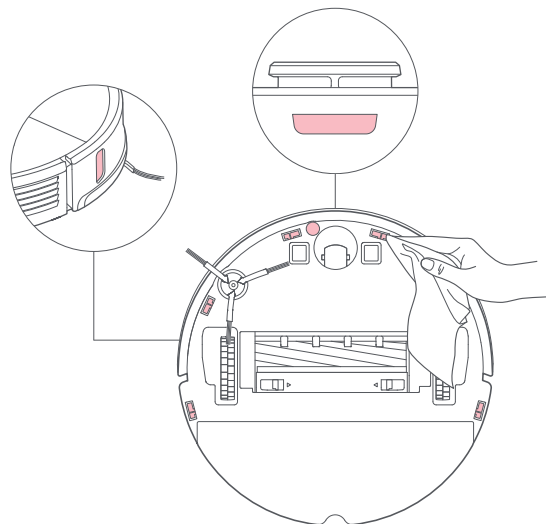

# Routine Maintenance

## Charging Contact Areas

Use a soft dry cloth to wipe the charging contacts on the charging dock and the robot.

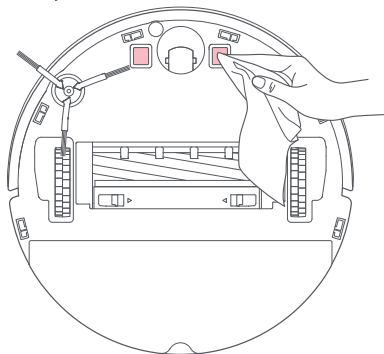
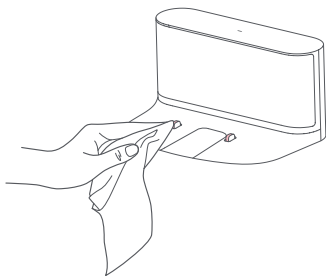

## Battery

The robot is equipped with a high-performance lithium-ion rechargeable battery pack. To maintain battery performance, keep the robot charged.

**Note:** If the robot will not be used for an extended period, turn it off and charge it at least every three months to avoid battery damage caused by over-discharging.

# Basic Parameters

## Robot

Model	roborock S7
Dimensions	353×350×96.5mm
Battery	14.4V/5200mAh lithium battery
Weight	Approx. 4.7kg
Wireless Connection	WiFi Smart Connect
Rated Input	20V 1.2A
Charging Time	< 6 hours

**Note:** The serial number is on a sticker on the underside of the robot.

## Charging Dock

Model	CDZ11RR or CDZ12RR
Dimensions	151×130×98mm
Rated Power	28W
Rated Input	100-240V~
Rated Output	20V 1.2A
Rated Frequency	50-60Hz

# Errors

If an error occurs while the robot is cleaning, the power indicator will flash red quickly, and a voice alert will sound. Refer to the following table for Troubleshooting.

Error	Solution
Error 1: Turn the laser unit and check that it is not jammed or blocked.	LiDAR unit is jammed. Rotate to clear it. Move the robot to a new location and restart.
Error 2: Clean and lightly tap the bumper.	The bumper is stuck. Lightly and repeatedly tap the bumper to remove any blockages. If none is found, move the robot to a new location and restart.
Error 3: Move the main unit to a new location and restart.	A wheel is suspended. Move the robot to a new location and restart.
Error 4: Clean cliff sensors, move the main unit away from any drops, then restart.	Move the robot away from raised edges, and restart. If the problem persists, clean the cliff sensors.
Error 5: Remove and clean the main brush and brush bearing.	The main brush is jammed. Remove it for cleaning, then reinstall and restart.
Error 6: Remove and clean the side brush.	The side brush is jammed. Remove it for cleaning, then reinstall and restart.
Error 7: Check that wheels are not blocked, then move the main unit to a new location and restart.	The main wheels may be jammed. Remove and clean them, then re-install and restart.
Error 8: Remove any obstacles around the main unit.	The robot is trapped. Clear away any obstacles around it and restart.
Error 9: Reinstall dustbin and filter.	Check that the dustbin and filter are correctly installed. If the problem persists, replace the filter.

# Errors

If an error occurs while the robot is cleaning, the power indicator will flash red quickly, and a voice alert will sound. Refer to the following table for Troubleshooting.

Error	Solution
Error 11: Strong magnetic field detected. Move the device away from barrier tape and restart.	A high-intensity magnetic field detected. Move the robot away from magnetic tape and restart.
Error 12: Battery level too low. Recharge before use.	Low battery. Recharge before use.
Error 13: Charging error. Cleaning charging contacts and try again.	Charging contacts are dirty. Wipe the contacts on the robot and the Charging Dock with a dry cloth.
Error 14: Battery error.	The battery temperature is either too high or too low. Wait until it returns to normal.
Error 15: Clean wall sensor.	The wall sensor is dirty. Wipe it clean.
Error 16: Place and start the main unit on a level floor.	The robot is tilted. Place it on a level surface and restart.
Error 17: Side brush module error. Reset the main unit.	The side brush module is experiencing a fault. Reset the system.
Error 18: Fan error. Reset the main unit.	The vacuum fan is experiencing a fault. Reset the system.
Error 21: Height sensor has been pressed. Move the main unit and restart.	The vertical bumper is jammed on. Move the robot to a new location and restart.
Error 22: Clean the dock locator on the robot.	The dock locator is dirty. Wipe it clean.
Error 23: Clean the transmission area on the charging dock.	The dock location beacon signal has been blocked by dust. Wipe it clean and retry.

# Errors

If an error occurs while the robot is cleaning, the power indicator will flash red quickly, and a voice alert will sound. Refer to the following table for Troubleshooting.

Error	Solution
Error 27: VibraRise Module Jammed.	The VibraRise module is jammed. Clear blockages and move the robot to a new location and restart.
Error 28: Carpet Detected.	The robot may be on a carpet. Move it from the carpeted area. If this is an error, wipe the carpet sensor and restart.
Check the filter. If wet, use a dry one. If dry, clean it and try again.	The filter is not completely dry. Dry the filter for at least 24 hours. The filter may also be blocked and require cleaning. If the problem persists, replace the filter.
No-Go Zone or Invisible Wall Detected.	Remove the virtual barrier or move the robot from the current position and restart.
Unable to Cross Carpet.	The robot cannot cross carpets when mopping. To continue, manually place the robot on the other side of the carpet and restart.
Internal Error.	Malfunction due to an internal error. Reset the system.

**Note:** A system reset may not resolve all problems.



# Common Issues

Problem	Solution
Unable to power on	The battery level is low. Put the robot on the charging dock and charge it before use. The battery temperature is too low or too high. Only use the robot within the range of 4-40°C (32-104°F).
Unable to charge	If the charging dock is not receiving power, check that both ends of the power cable are properly connected. If contact is poor, clean the contact areas on the charging dock and the robot. When the power indicator light turns on, power is normal.
Slow charging	When used at high or low temperatures, the robot will automatically reduce its charging speed to extend battery life. The charging contacts may be dirty. Wipe them with a dry cloth.
Unable to dock	There are too many obstacles near the charging dock. Move it to an open area. The robot is too far from the charging dock. Place it closer and retry.
Abnormal behavior	Restart the robot.
Noise during cleaning	The main brush, side brush, main wheels, or omni-directional wheel may be jammed. Turn off the robot and clean them.
Unable to connect to WiFi	WiFi is disabled. Reset the WiFi and try again. The WiFi signal is poor. Move the robot to an area with good WiFi reception. Abnormal WiFi connection. Reset the WiFi, download the latest mobile app, and retry. The current Roborock robot is not supported. You can find supported models in the app. Unable to connect to WiFi. There may be an error with your router settings. Contact Roborock customer service for additional support.

# Common Issues

Problem	Solution
Poor cleaning ability or dust falling out	The dustbin is full and needs emptying. The filter is blocked and needs cleaning. The main brush is jammed and needs cleaning.
Scheduled cleaning is not working	Keep the robot charged. Scheduled cleaning can only begin when the battery level is above 20%.
Is power always being drawn when the robot is on the charging dock?	The robot will draw power while it is docked to maintain battery performance, but power consumption is minimal.
Does the robot need to be charged for at least 16 hours the first three times it is used?	No. The robot can be used any time after it has been fully charged.
No or little water during mopping	Follow the instructions in the user manual to correctly install the mop cloth and mop cloth bracket, and check whether there is water in the water tank.
Cleaning does not resume after recharging	Make sure that the robot is not in DND mode. DND mode will prevent cleanup. When cleaning a space requiring a top-up charge, if the robot was placed manually on the charging dock before it returned to the dock automatically, it will not be able to continue cleanup.
The robot cannot return to the charging dock after Spot cleaning or when it has been moved manually.	After spot cleaning or a significant position change, the robot will re-generate the map. If the charging dock is too far away, it may not be able to return to recharge and must be placed on the charging dock manually.
The robot has begun to miss certain spots	The wall sensor or cliff sensors may be dirty. Wipe them with a soft dry cloth.
It takes a long time to fill the water tank	The filter may be blocked and need cleaning.



## Robot Vacuum Cleaner

Manufacturer: Beijing Roborock Technology Co., Ltd.

Product Model: roborock S7

Address of Manufacturer: Floor 6, Suite 6016, 6017, 6018, Building C, Kangjian Baosheng Plaza,  
No.8 Heiquan Road, Haidian District, Beijing, P.R.CHINA

For more product information, visit our website: [www.roborock.com](http://www.roborock.com)

For after-sales support, email our after-sales service team:

US/Non-Europe Support: [support@roborock.com](mailto:support@roborock.com)

Europe Support: [support@roborock-eu.com](mailto:support@roborock-eu.com)

