

(Plan structure diagram: Unit: MM)

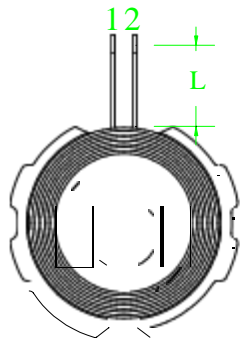
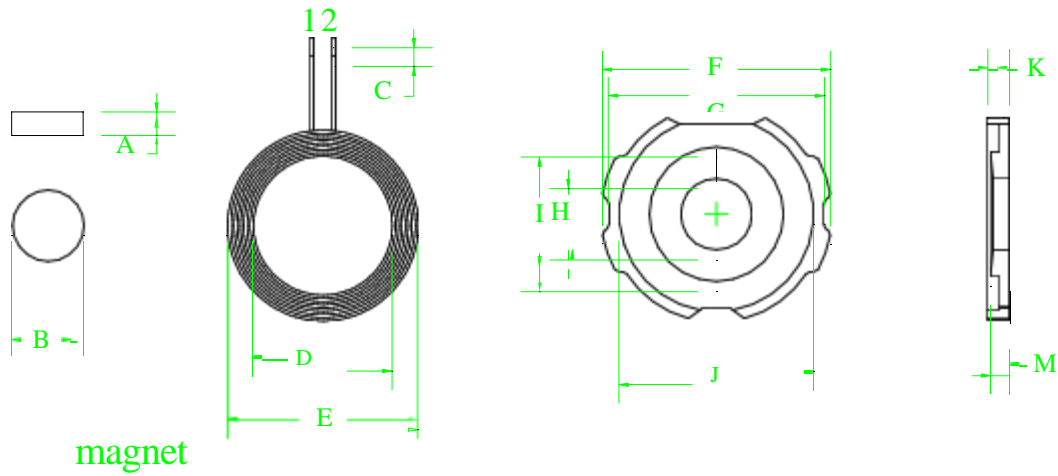

A	2 ±0.1
B	7.5 ±0.05
C	1.5 ±0.5
D	15 ±0.2
E	20.5 ±0.5
F	25 ±0.3
G	23.5 ±0.3
H	7.8 ±0.05
I	135 ±0.1
J	21 ±0.2
K	2.75 ±0.1
L	6.0 ±1.0
M	2.5 ±0.05

(Product parameters) :

(Foot position)	(Wire diameter)	(Number of laps)	(remarks)
1 -- 2	0.08*24P	1211	(Hot air twisted wire)

(technical requirement) :

1.

Fix the wire ends and prevent loose or broken wires

2

Cut the excessively long wire ends according to customer requirements, tin them with a uniform depth of $1.5 \pm 0.5\text{MM}$

3

Apply appropriate white glue on the hard magnetic sheet, attach the coil, and ensure that the product surface is clean and tidy during the process

4.

Additional process (as requested by the customer): Install a 7.5x2.0mm magnet into the circular hole in the middle of the finished product and apply a 23.5mm round double-sided foam adhesive to the back of the product. The ear length is 4mm, and then package it

(Electrical parameters) :

Inductance value, Q value: PIN 1-2= $6.4\mu\text{H} \pm 0.3\text{UH}$

Q value ≥ 27 . For inductance values, use the Tonghui 2817B instrument, with 100KHZ/0.3Vrms as the standard or equivalent instrument.

The Q value is based on the Tonghui 2817B instrument, with 100KHZ/0.3Vrms as the standard or equivalent instrument

(Material List) :

(Serial number)	(name)	(texture of material)	(supplier)	(Prepare)
1	(Hot air twisted wire)	0.08X24P		
2	(Magnetic)	(88 hard substrate)		
3	(tin)	(High temperature environmental protection)		
4	(White glue)	BY882		
5	(Strong magnetic field)	7.50*2.0 (> 3000GS)		
6	(Double sided foam adhesive)	23.5mm		Ear Length 4mm