

Shenzhen Ruitong thousand industry technology Co., LTD

客户/Ciient名称/

TYPE A28 Wireless charging transmitter coil

product model

Model NO G43.5*0.6 Double slot with hole back adhesive length 210MM/0.07*100

产品编号 Part numbering systey

Customer Material Number Cient p/NO

工程编号

Enginrer NO

日期/Date 2024年7月3日

本公司工程部/For Enginer Departner Only	
修改内容/Rvised Cintent	认可日期/APProved Date

编制/Prepared

审核/Checked

认可/Approved

万纪美

万纪美

刘成昭

客户认可回签/Authorixed Signaturure Company Chop		
工程/ Enginrer	认可/QC APProved	认可日期/APProved

Wireless coil manufacturer: Shenzhen Ruitong thousand industry technology Co., LTD
Address: RM301, No.30 Xincheng Road, Xinzhuang Community, Matian Street, Guangming District, Shenzhen

Shenzhen Ruitong thousand industry technology Co., LTD

一、线圈工艺/Winding Procese:

NO	winding	guage	number of turns	direction of	winding
1	N1	2UEW-B-0.07*100	10TS	CCW	
2					

二. 电气性能/FEATURES:

1.测试条件 (Test conditions) : 25°C,65%RH@100KHz/1V

1.1 电感量 (Inductance)

1.11 L0A(线圈+磁片)=6.3uH±5%

1.2 Q 值=80MIN

1.3 直流电阻 (DCR) : 40mΩ MAX

1.4 工作温度(Operating Temperature): -25°C~85°C

2.测试仪器(Test instrument): L:创达 1068+1310;DCR:502BC;SIZE:Callipers

3.材料清单

NO	项目	材料
1	WIRE	φ 0.07*100 2UEW-
2	FERRITE	43.5*0.6L double slot perforated ferrite hard magnetic back double-sided tape
3	GLUE	Water-based white glue
4	SOLDER	HQ-996/JS-996
5	Tin	Thousand Island tin
6	High temperature adhesive	8MM high-temperature tape
7		
8		

三. 电路图/CIRCUIT DIAGRAM

Shenzhen Ruitong thousand industry technology Co., LTD

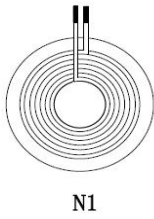

单位: MM

四. 外形图/OUTSIDE DIAGRA

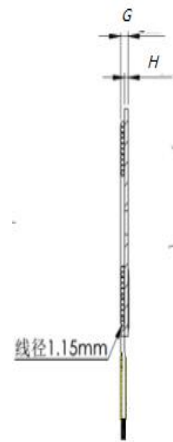
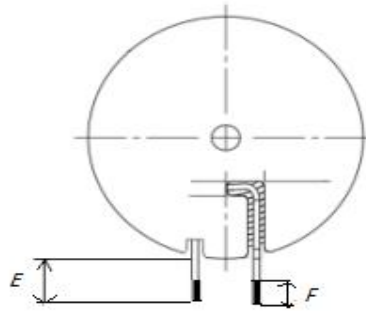
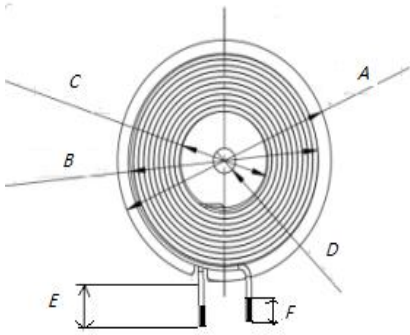

Note: Wrap 8MM (ref) high-temperature adhesive paper around the coil outlet position, and attach double-sided adhesive on the back of the magnetic disc.

标准	A	B	C	D	E	F	G	
STD	43.5±0.5	40±0.5	20.5±0.2	5±0.2	210±2	3±1	2.0±0.3	

单位: MM

五. 包装/PACKAGE

5.1 包装图片 Packing pictures:

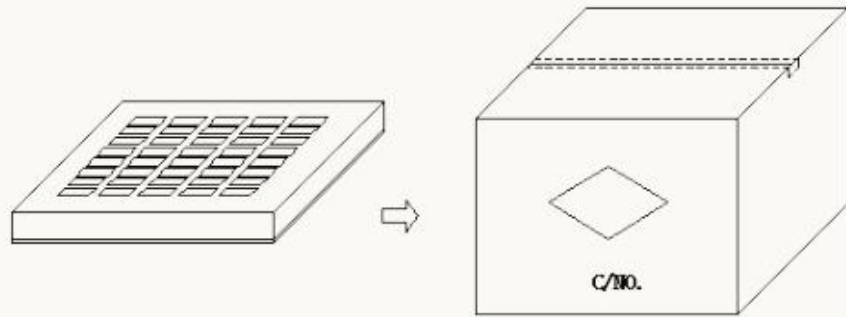

5.2 包装数量及规格 Packing Quantity:

项目 Item	数量 Quantity	材料规格 Material
盒 Box	350 Pcs	345*330*50 mm
箱 Big Carton	1750 Pcs	360*340*280 mm

5.3 包装以现有包装盘为参照标准，以实际出货包装为准，如有特殊要求可定制。

The packaging shall be based on the exusting packing plate and the actual delivery package shall prevail .If there is any requirement,we can customize it.

Shenzhen Ruitong thousand industry technology Co., LTD

六、贮存和使用条件 Storage and Use condition

6.1 贮存条件 Storage condition

6.1.1 建议贮存条件：温度 $-25^{\circ}\text{C} \sim 85^{\circ}\text{C}$ ，湿度 70% (Max.)

Recommended keeping conditions: $-25^{\circ}\text{C} \sim 85^{\circ}\text{C}$, 70%RH (Max.)

6.1.2 贮存期限：自生产之日起六个月内

Storage life : Within the limits of six months from being produced.

6.2 使用条件 Use condition

使用条件限制：温度 $=-25^{\circ}\text{C} \sim 85^{\circ}\text{C}$ ，湿度 $\leq 90\%$

Use condition limit: $T=-25^{\circ}\text{C} \sim 85^{\circ}\text{C}$, $\text{RH} \leq 90\%$.