

specification



Specification number	202408024001
availability date	2024/8/24

customer name	Ai small electricity
product type	coil
Top wisdom material number	TX-DZ43.505.3006-K6.5-L40 Open the double groove
Customer material number	

[✓ ✓ New version release, version revision] [This specification contains 7 pages of the directory] [RoH S CompliantParts]

authorized strength	examine and verify	ratify
The clock to establish	/	Ma Xiangping

Guangdong Dingzhi Electronic Technology Co., LTD

Factory Address: 1st Floor, No.1231, Yingbin Avenue, Longmen County, Huizhou City, Guangdong Province

Tel. : 13147097490

This acceptance must be returned within 30 days of receipt by the customer, which shall be deemed to be executed according to the standard of this acceptance.

[Customer Approval] Date:

Admission status: fully acknowledged conditional recognition refused to admit

ratify	examine and verify	recheck	check up

explain:

specification

customer name	Ai small electricity	Customer material number	
Top wisdom material number	TX-DZ43.505.3006-K6.5-L40 open double groove	Specificati on number	202408024001
Issue / Revision Records			
editio n	availability date	Change the content / reason	approval
01	2024/8/24	New specifications issued	Ma Xiangping
authorized strength	examine and verify	ratify	

The clock to establish	/	Ma Xiangping	
---------------------------	---	-----------------	--

specification

customer name	Ai small electricity	Customer material number			
Top wisdom material number	TX-DZ43.505.3006-K6.5-L40 open double groove	Specification number	202408024001	edition	01

◆, outline dimension

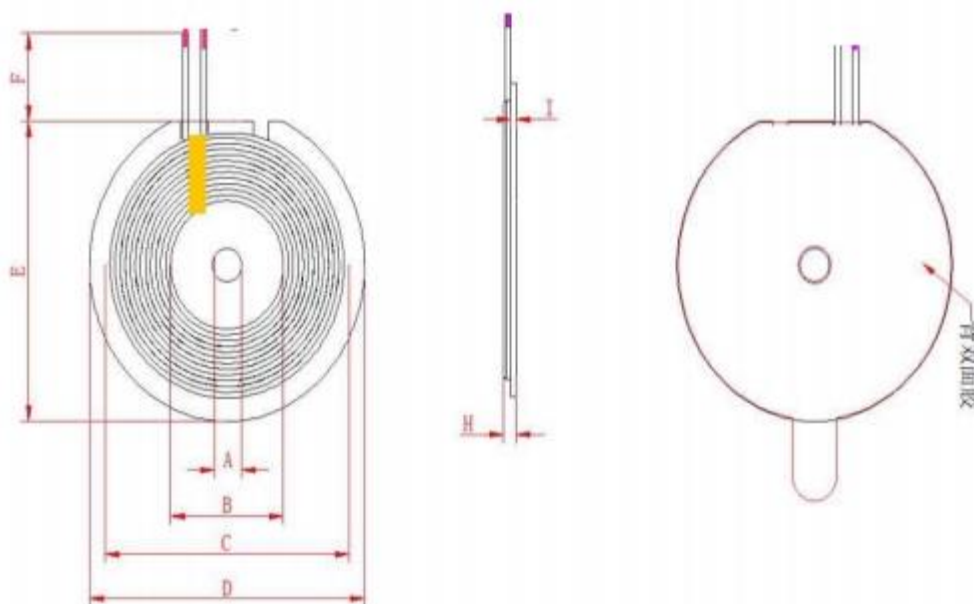

(unit:mm)

A	5.3±1.5
B	20.5±1.5
C	38.5±1.5
D	43.5±1.5
E	43.0±1.5
F	40.0±2.0
H	1.7±0.3
I	0.60 ± 0.1 (magnetic chip thickness)

(1) Line diameter: 0.08 * (24 * 2P) enameled wire

(2) Number of winding coil: 10TS

(3) Whether the starting and tail line crosses: yes

(4) Coil wrap 4mm wide high temperature tape

(5) The coil and the magnetic film should be pasted in the center

(6) Magnetic film back 42 round white glue

◆, electrical character:

parameter	specifications	test condition	measuring and test instruments
L0	6.5±10%μH	100KHz/1V	■ TH1816B
Q	>30 min	100KHz/1V	■ TH1816B
DCR	<95mΩ	@25°C	■ CH-502 BC

◆, temperature grade:

service temperature	-40°C~125°C
---------------------	-------------

◆, bill of material:

order number	name of a part	material specification	supplier	remarks
1	magnetic sheet	43.5*5.3*0.6T Open the double groove		PC40 fierce zinc

2	copper line	0.08* (24*2P)		varnished wire			
3	High temperature tape	4MM		Environmental protection tape			
4	glue	42 Round white glue		Environmental rubber paper			
5	tin	107H		Thousand island environmental protection tin			
6	glue	Yellow gum		Environmental glue			
authorized strength		examine and verify			ratify		
The clock to establish		/			Ma Xiangping		