

Product Maintenance

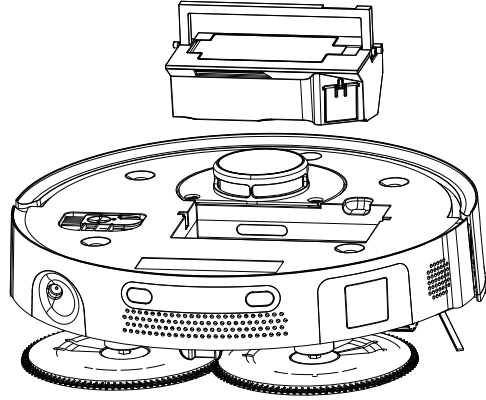

Lift the dust box handle up and take out the dust box.

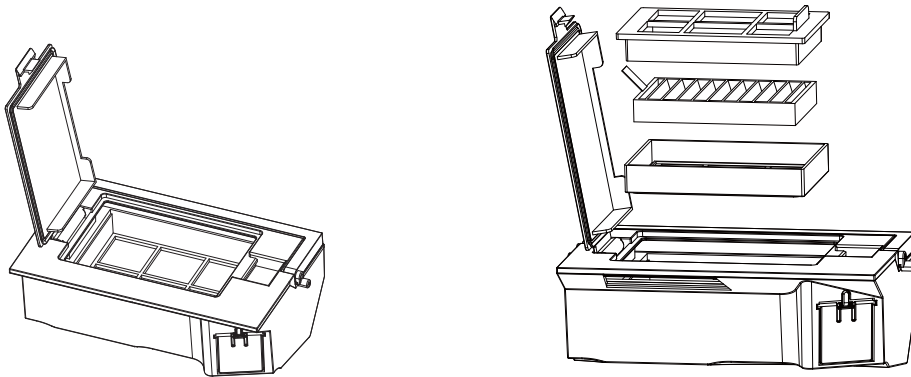

Open the flip cover of the dust box, and take out the Hypa bracket, HEPA filter and Hypa silica gel. It is not recommended to wash the high-efficiency filter, please tap it to remove dust

Product Maintenance

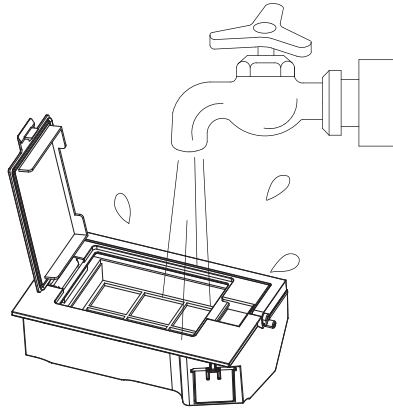

After rinsing the dust box, shake the water from the dust outlet vigorously.

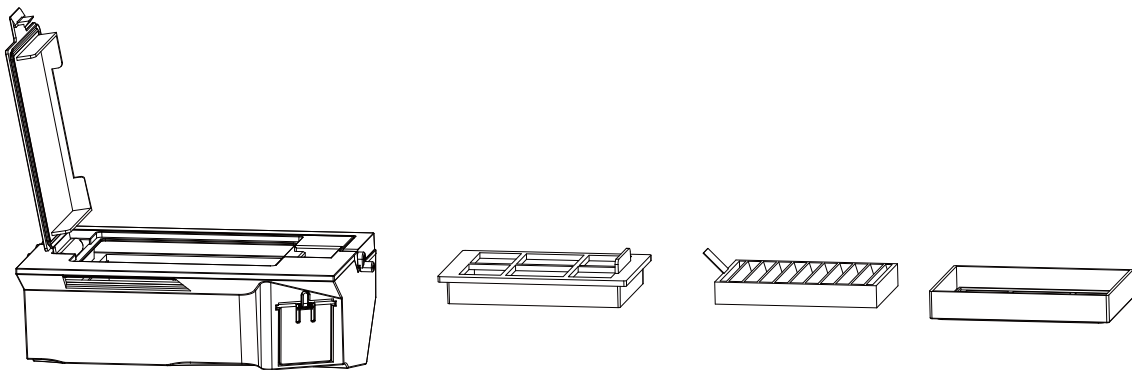

Dry the dust box and filter material components and keep them dry to ensure their service life. When the dust box is used for 15-30 days, it is recommended to wash it once. The maximum service life of the high-efficiency filter is 3 months.

Product Maintenance

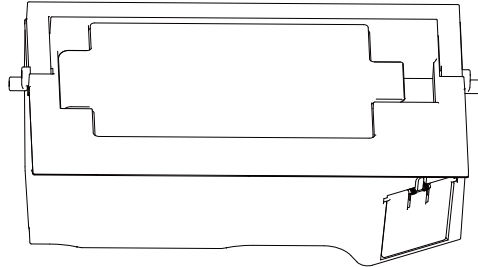

Reinstall the Hypa bracket, Hypa silica gel and high-efficiency filter back into the dust box
Before installing the filter, please ensure that the primary filter and the high-efficiency filter in the dust box are in a dry state. Do not expose the high-efficiency filter and the primary filter to the sun.

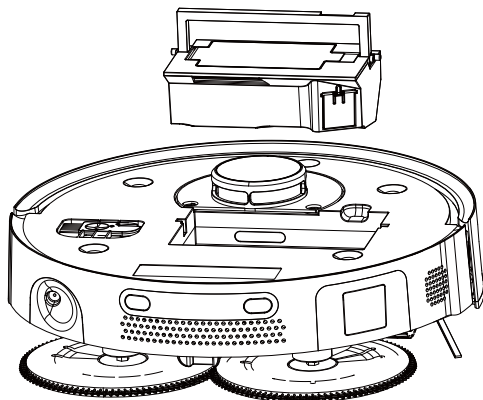

Put the dust box on the dust box position of the machine.

Product Maintenance

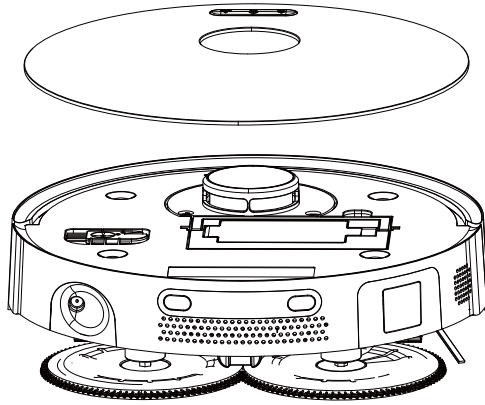

Close the magnetic cover to complete the installation of the dust box.

5.3 Maintenance of mop components

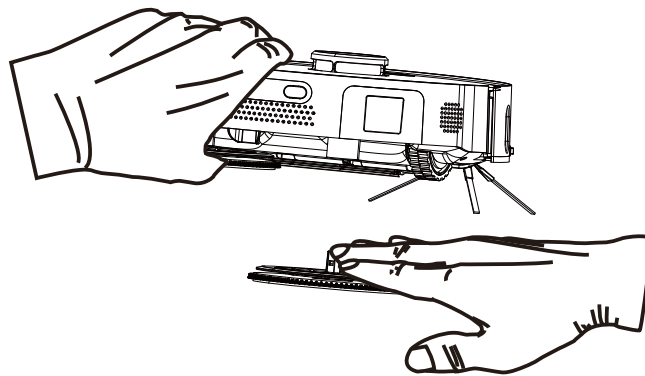

Lift up the rear of the machine and press firmly on the mop assembly to remove it. Prevent water on the mop from seeping inside the machine and causing damage.

Product Maintenance

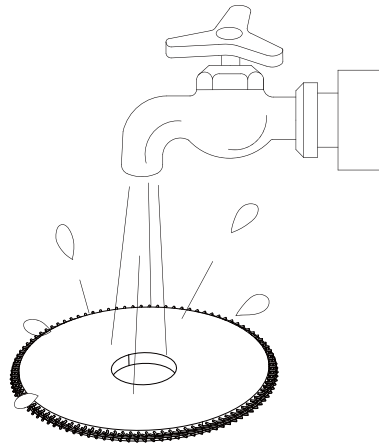
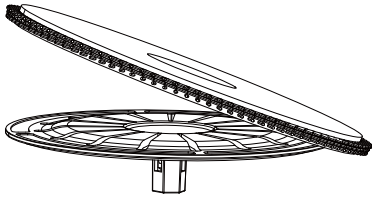

Peel the soaked mop off the mop holder. Then rinse and dry the water seepage mop.

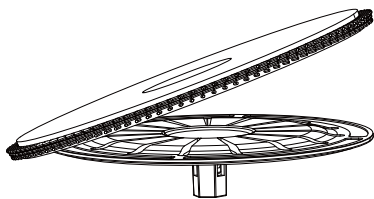

Put the dried mop on the mop holder.

Product Maintenance

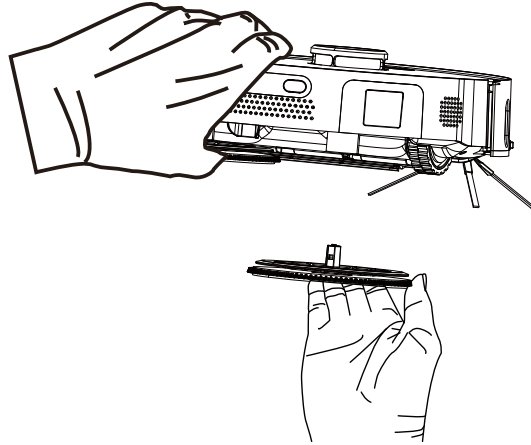

Hold up the rear of the machine, align the mop assembly with the machine mount and press firmly to fit.

Product Maintenance

5.4 Base station maintenance

pallet maintenance

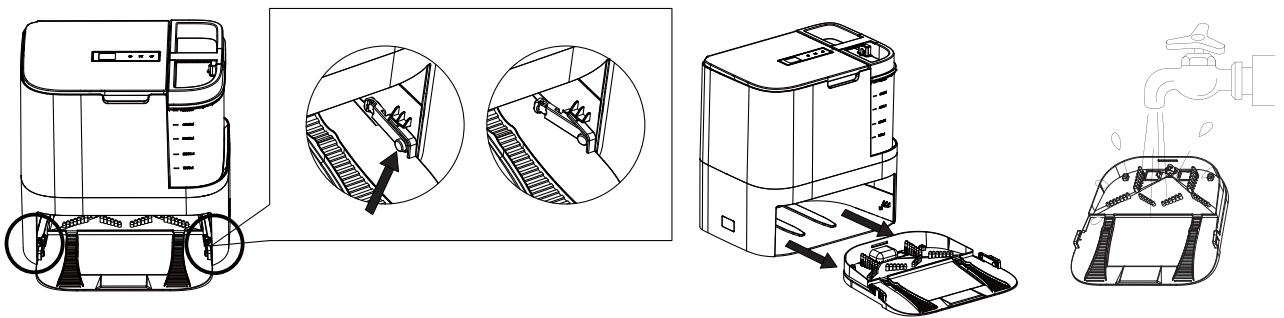

Press the retaining buckles on both sides to disengage the washable tray buckles from the base station. Then pull out the washable tray. Rinse and put back into the base station.

Replace the

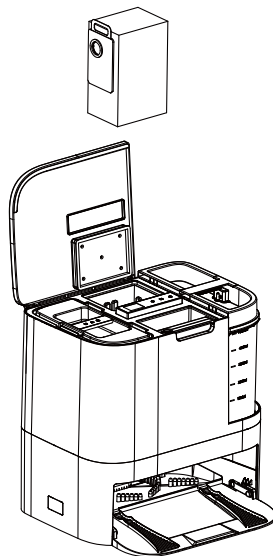

Open the top cover, pinch the handle of the dust bag and pull it up, so that the dust bag is detached from the base station. Then follow the step of placing the dust bag and replace with a new dust bag.

Product Maintenance

Recovery tank maintenance

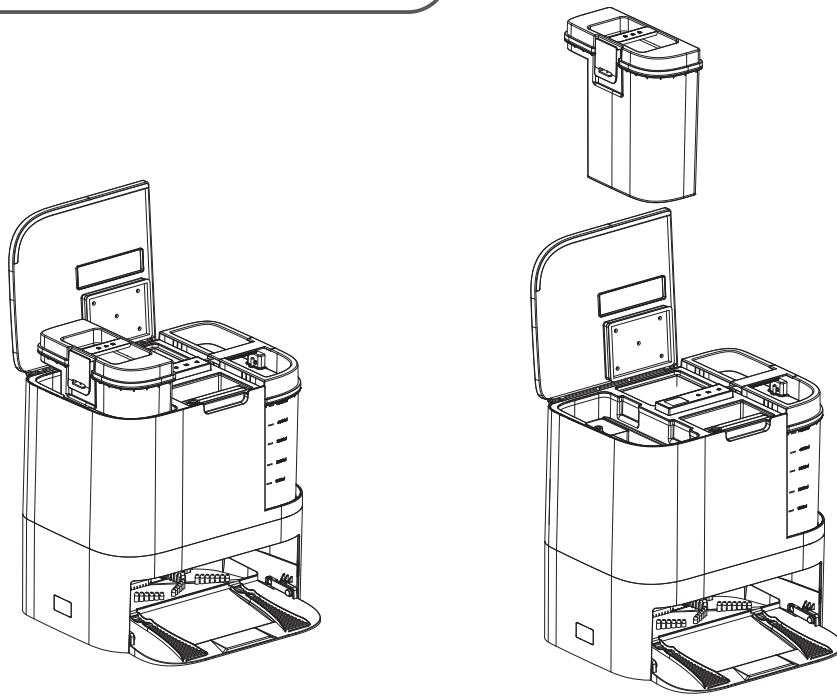

Open the top cover, lift up the sewage tank vertically, and take out the sewage tank.

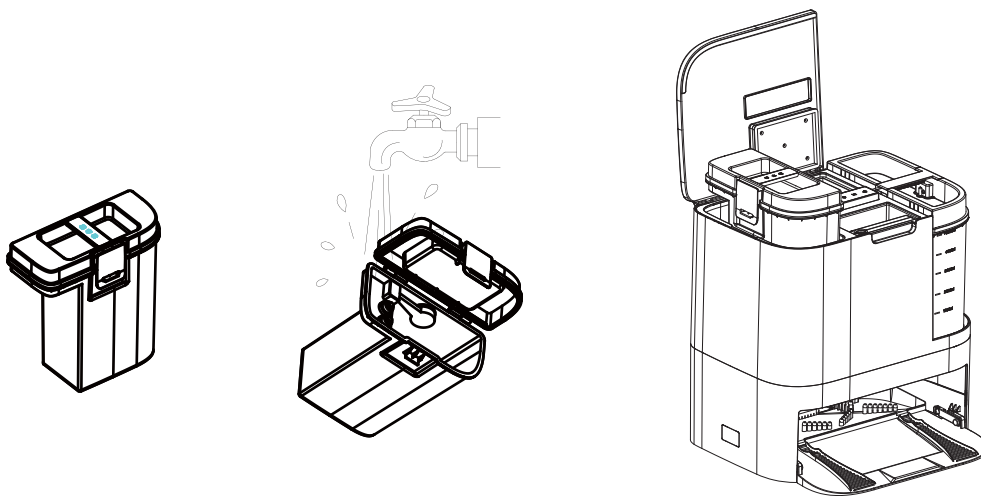

Open the cover of the sewage tank, dump the sewage in the sewage tank, rinse the sewage tank, and install it back to the base station.

Product Maintenance

5.5 Maintenance of Roller Brush Assembly

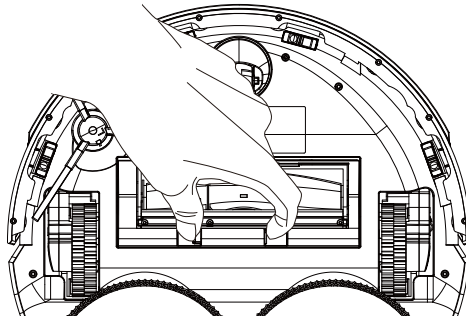

Hold the elastic buckle of the roller brush cover with your hands, and pull up to open the roller brush cover assembly

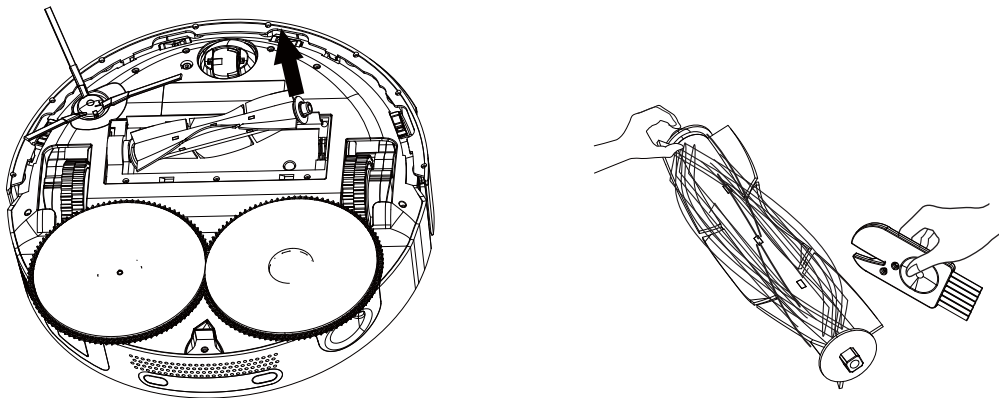

Take out the roller brush shaft, and clean the sundries and hair on the roller brush shaft.

Product Maintenance

5.6 Maintenance of other components

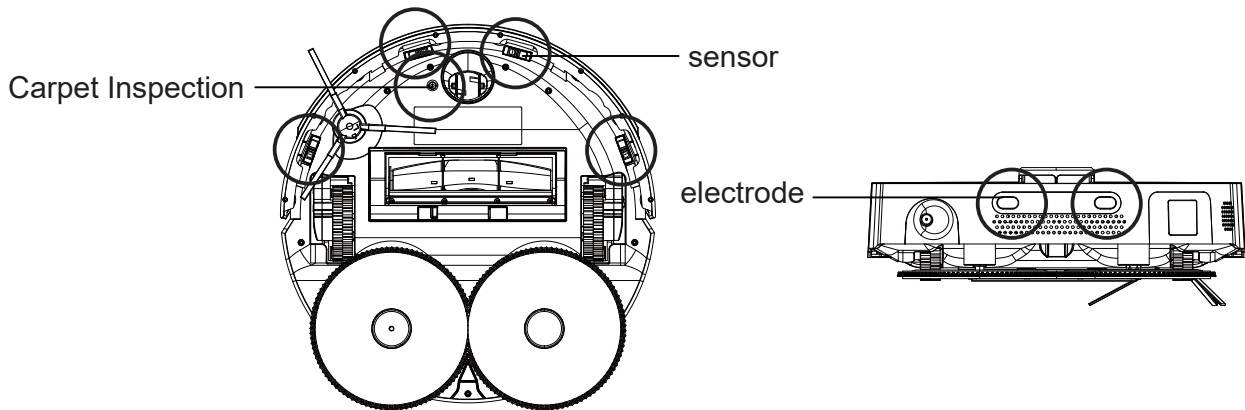

Occasionally use a cleaning tool or a dry soft cloth to gently wipe the machine chassis sensor window and carpet detection window, as well as the charging electrode sheet on the back of the machine.

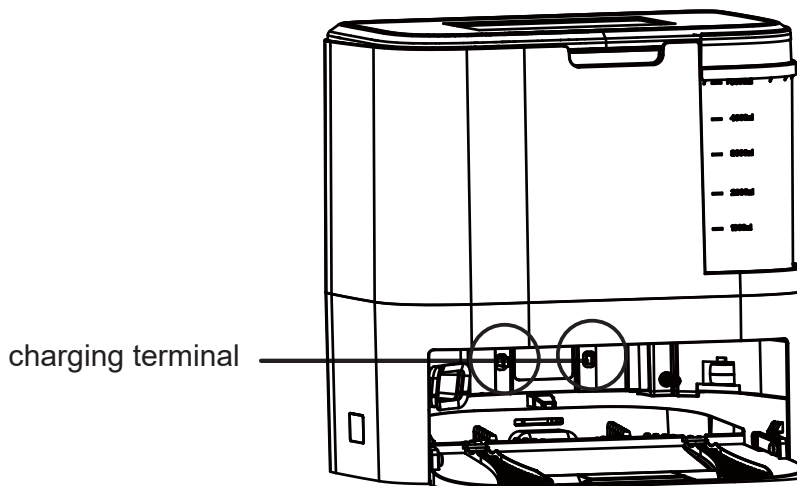

Clean the terminals of the charging stand with a dry cleaning tool or a soft cloth after power off

Common malfunctions

6.1 Fault description

Host failure description

Fault conditions	Possible Causes	solution
The host cannot be charged	The host and the charging pole of the base station are not in full contact.	Make sure that the main unit is fully connected to the charging pole piece of the charging base station.
	The power of the charging base station is turned off, and the power switch of the main unit is turned on, resulting in power consumption.	When the main unit is not performing work, it is recommended to keep it in a charging state, so as to better carry out the next work.
Stuck when host works	The main unit is hindered by entanglement of scattered wires on the ground, drooping curtains or carpet fringes.	The host will try various methods to get out of trouble independently. If it fails to get out of trouble, it is recommended to help manually.
The cleaning is not completed, the host returns to charge	The main unit can sense the lack of power when it is working, and it will automatically return to charging.	Charge the host.
	Wooden floors, ceramic tiles and other flat ground hosts work at different speeds and for different periods of time.	The working time of the host varies with the complexity of the room, the amount of garbage and the cleaning mode.
The host does not automatically clean according to the scheduled time	The host power switch is not turned on, and the host cannot work by itself according to the agreed time when it is turned off.	Turn on the host power switch.
	The power of the main unit is low.	When the host is in standby, it should be kept charging on the charging stand to ensure that it has sufficient power to work at any time.
	The host components are clogged and entangled with garbage.	Turn off the power, clean the dust box and turn the bottom of the host up. Clean each part separately.
When the main machine is working, there are phenomena such as missed scanning, chaotic routes, deviation, and irregular and untidy display of the cleaning Figure on the APP side.	It may be that when the main engine climbs small steps, thresholds, and door bars, the driving wheel and the ground slip, which affects the main engine's judgment on the working environment of the whole house.	It is recommended to close the door to the area and clean the area separately. The main unit has the function of independently identifying single rooms, and it will return to the starting point after cleaning, so please feel free to use it.
	Work on freshly waxed, polished floors or smooth surface tiles, resulting in less friction between the drive wheels and the floor	It is recommended that you wait for the floor wax to dry before cleaning.
	Wires, slippers and other objects placed on the ground affect the normal operation of the host	Before the host works, please sort out the scattered wires, slippers and other objects on the ground to reduce the scattered items on the ground as much as possible.

Common malfunctions

Base Station Fault Description

Fault conditions	Possible Causes	solution
Unable to fill the sweeper with water	Clean water tank is not installed.	Install the clean water tank correctly.
	Clean water tank lacks clean water.	Add clean water to the clean water tank.
No water was added to the tray when the base station was self-cleaning	Clean water tank is not installed.	Install the clean water tank correctly.
	Clean water tank lacks clean water.	Add clean water to the clean water tank.
	The tray is full of dirty water.	Click the self-cleaning button on the base station body to switch to the water suction mode. After the water in the tray is sucked away, the self-cleaning will start again.
	The tray is not installed correctly.	Check whether the buckles on the left and right ends of the tray are in place.
Tray water overflow	The base station tray was not installed properly, causing water leaks.	Install the base station tray correctly.
	The tray full sensor is clogged with dirt.	Remove the tray and wash the tray manually.
Unable to suck up tray sewage	Recovery tank not installed properly.	Correctly install the recovery tank.
	Recovery tank not fastened properly.	Snap the waste water tank tight and fit properly into place.
	The recovery tank is full.	Pour out the waste water from the waste water tank.
	The suction port of the tray is blocked by dirt.	Clean the filter cover of the water suction port in time.
Unable to collect dust normally	The dust bag is not installed correctly.	Install the dust bag correctly.
	The dust bag is full of trash.	Replace with a new dust bag.
	The dust cover is not closed when collecting dust.	The dust collection cover should be closed when collecting dust.
Unable to charge the host	Base station charging metal terminal contacts are dirty.	After power off, clean the charging metal terminal contacts.

Common malfunctions

6.2 Replaceable modules

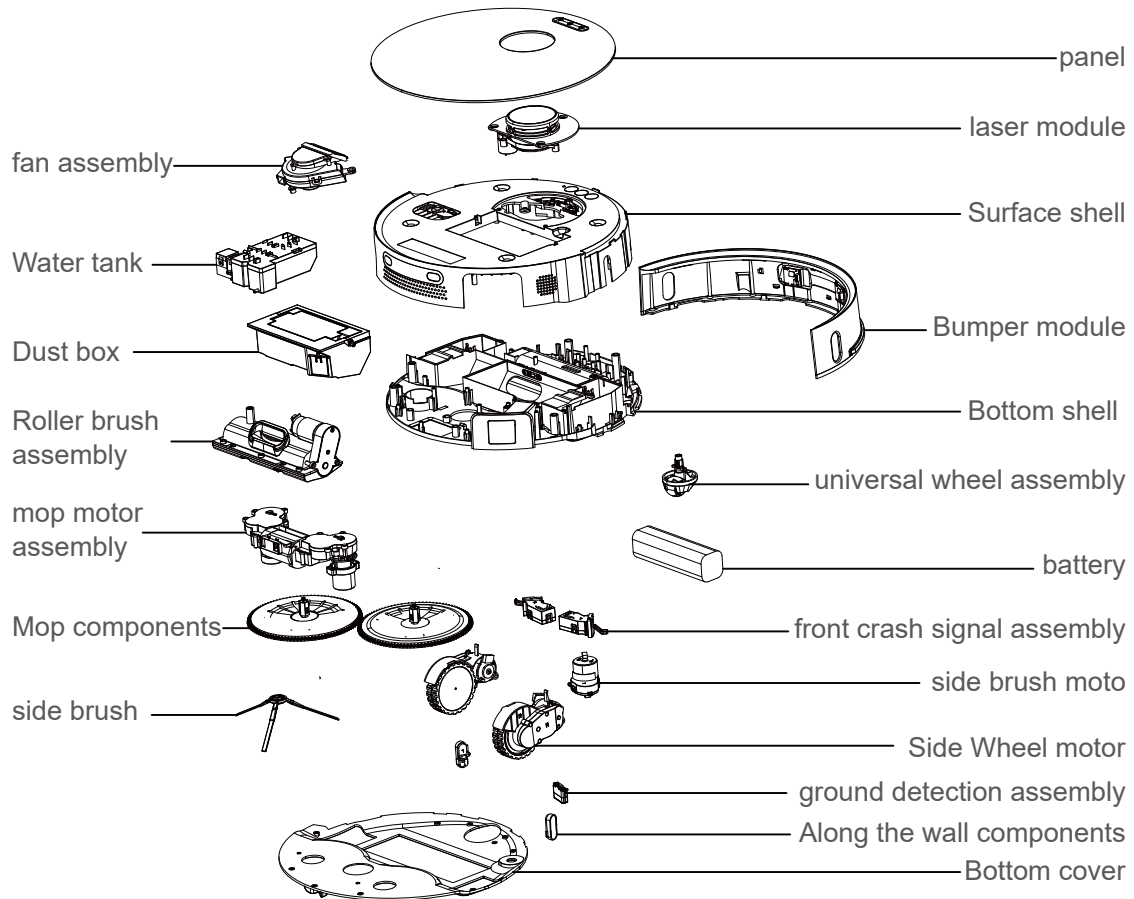

scope of application

This product is suitable for the cleaning of family houses, hotel rooms, and small offices. For all kinds of short and long carpets (carpet hair less than 1.5 cm), wooden floors, hard floors and ceramic tiles have a good cleaning effect.

FCC compliance statement

This device complies with Part 15 of the FCC Rules. Operation is subject to the following two conditions: (1) this device may not cause harmful interference, and (2) this device must accept any interference received, including interference that may cause undesired operation.

changes or modifications not expressly approved by the party responsible for compliance could void the user's authority to operate the equipment.

This equipment has been tested and found to comply with the limits for a Class B digital device, pursuant to Part 15 of the FCC Rules. These limits are designed to provide reasonable protection against harmful interference in a residential installation. This equipment generates, uses and can radiate radio frequency energy and, if not installed and used in accordance with the instructions, may cause harmful interference to radio communications. However, there is no guarantee that interference will not occur in a particular installation.

If this equipment does cause harmful interference to radio or television reception, which can be determined by turning the equipment off and on, the user is encouraged to try to correct the interference by one or more of the following measures:

- Reorient or relocate the receiving antenna.
- Increase the separation between the equipment and receiver.
- Connect the equipment into an outlet on a circuit different from that to which the receiver is connected.
- Consult the dealer or an experienced radio/TV technician for help.

FCC Radiation Exposure statement

This equipment complies with FCC radiation exposure limits set forth for an uncontrolled environment. This equipment should be installed and operated with minimum distance 20cm between the radiator and your body. This transmitter must not be co-located or operating in conjunction with any other antenna or transmitter.

Hereby, [MANUFACTURER] declares that the radio equipment type [Model No.] is in compliance with Directive 2014/53/EU. The full text of the EU declaration of conformity is available at the following internet address: [www.http:\\xxxxx](http://xxxxx)

This equipment complies with radiation exposure limits, it should be installed and operated with minimum distance 20cm between the radiator and your body. This transmitter must not be co-located or operating in conjunction with any other antenna or transmitter.

