



## 7.7 PEAK POWER SPECTRAL DENSITY

<b>Product</b>	: EUT-Sample	<b>Test Mode</b>	: See section 3.4
<b>Test Item</b>	: Peak Power Spectral Density	<b>Temperature</b>	: 25 °C
<b>Test Voltage</b>	: DC 3.8V	<b>Humidity</b>	: 56%RH
<b>Test Result</b>	: PASS		

Band	Channel	Frequency (MHz)	Total PSD (dBm)	Limit (dBm)	Verdict
<b>20MHz(IEEE 802.11a/n/ac)-worst</b>					
1	Low	5180	-1.94	11	Pass
	High	5240	-1.65	11	Pass
2	Low	5260	-1.69	11	Pass
	High	5320	-2.84	11	Pass
3	Low	5500	-2.12	11	Pass
	High	5700	-0.54	11	Pass
4	Low	5745	-3.86	30	Pass
	High	5825	-3.26	30	Pass
<b>40MHz(IEEE 802.11n/ac)-worst</b>					
1	Low	5190	-4.91	11	Pass
	High	5230	-5.36	11	Pass
2	Low	5270	-6.52	11	Pass
	High	5310	-6.38	11	Pass
3	Low	5510	-6.08	11	Pass
	High	5670	-3.67	11	Pass
4	Low	5755	-7.25	30	Pass
	High	5795	-7.93	30	Pass
<b>80MHz(IEEE 802.11ac)-worst</b>					
1	Low	5210	-10.3	11	Pass
2	Low	5290	-9.98	11	Pass
3	Low	5530	-9.17	11	Pass
	High	5610	-10.04	11	Pass
4	Low	5775	-12.91	30	Pass





Report No.: WSCT-A2LA-R&E230300002A-Wi-Fi2

Certificate #5768.01

For Question, Please Contact with WSCT www.wsct-cert.com

20MHz(IEEE 802.11a/n/ac)

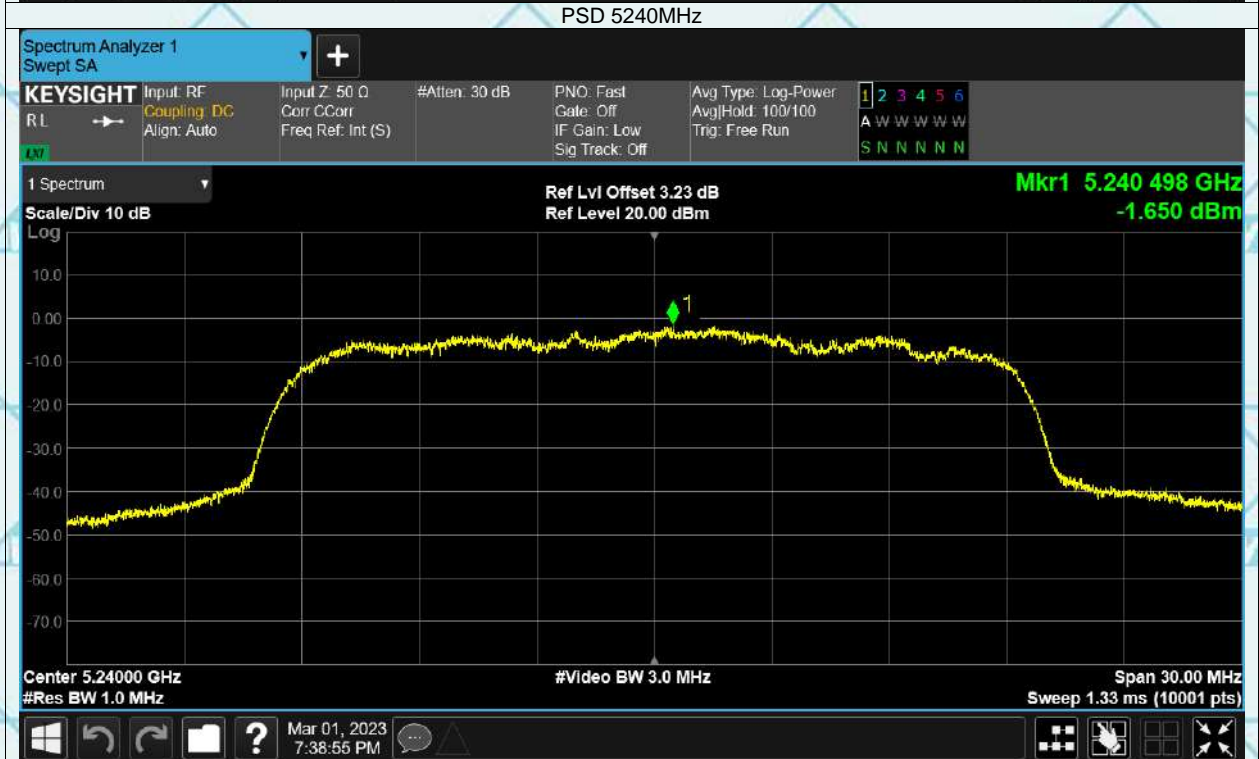
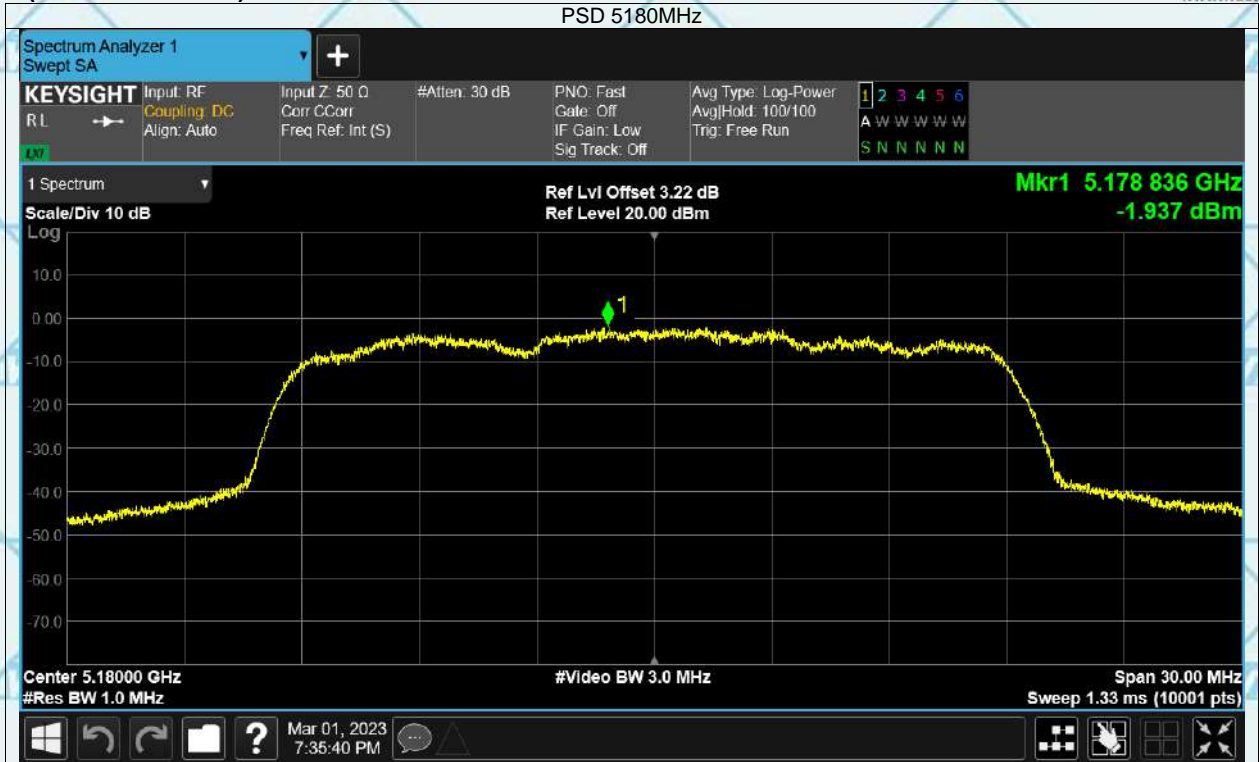

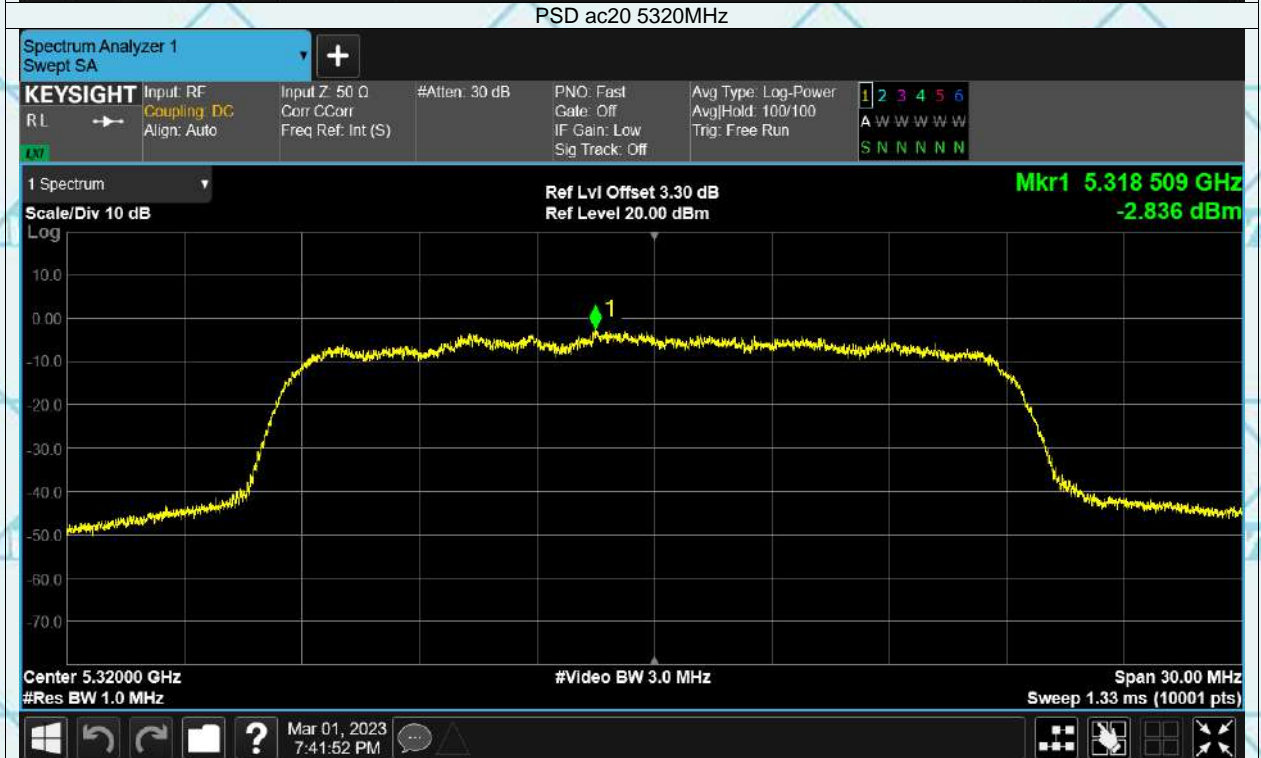



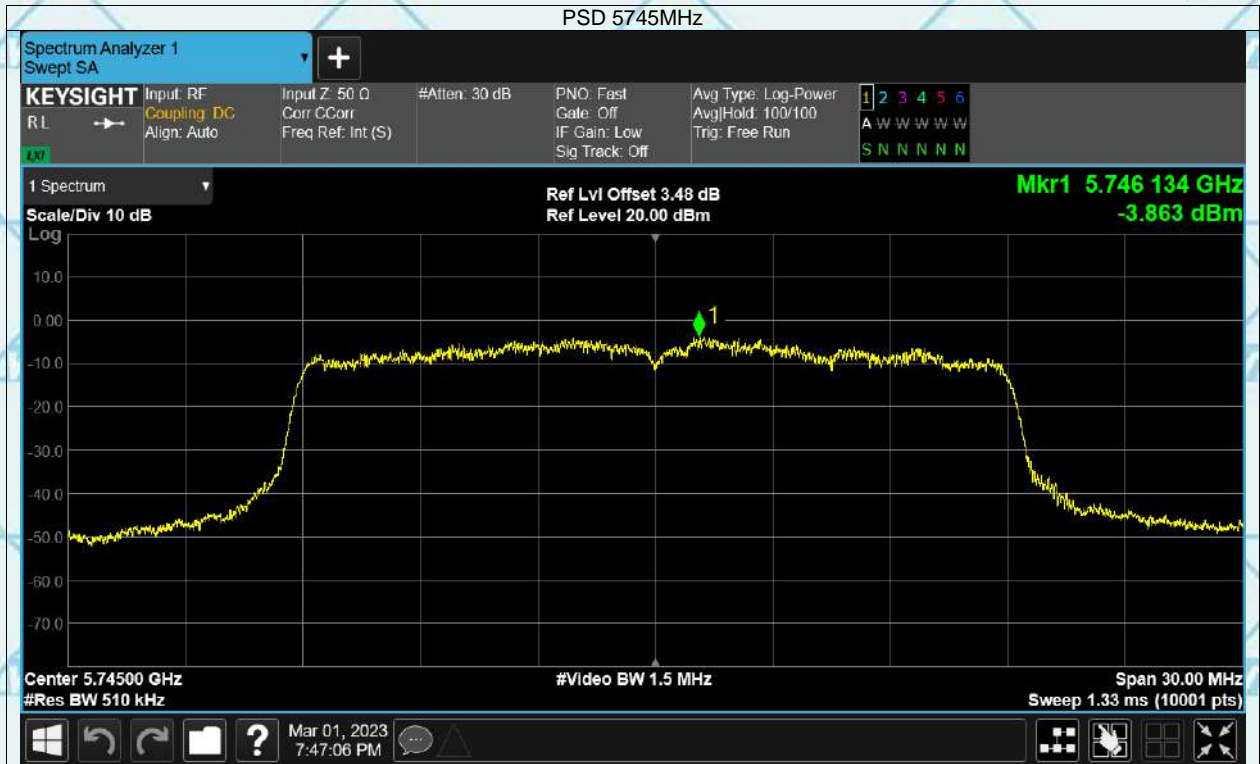



Report No.: WSCT-A2LA-R&E230300002A-Wi-Fi2

Certificate #5768.01

For Question, Please Contact with WSCT www.wsct-cert.com

40MHz(IEEE 802.11n/ac)

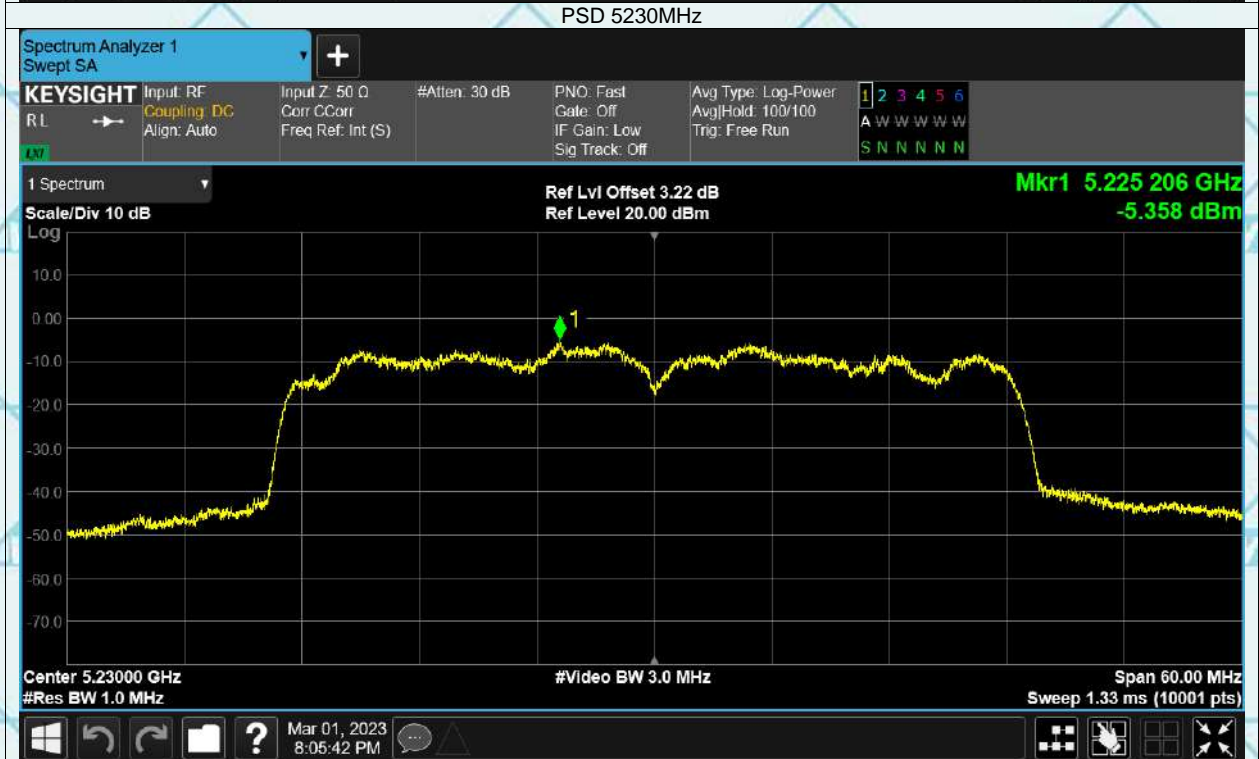
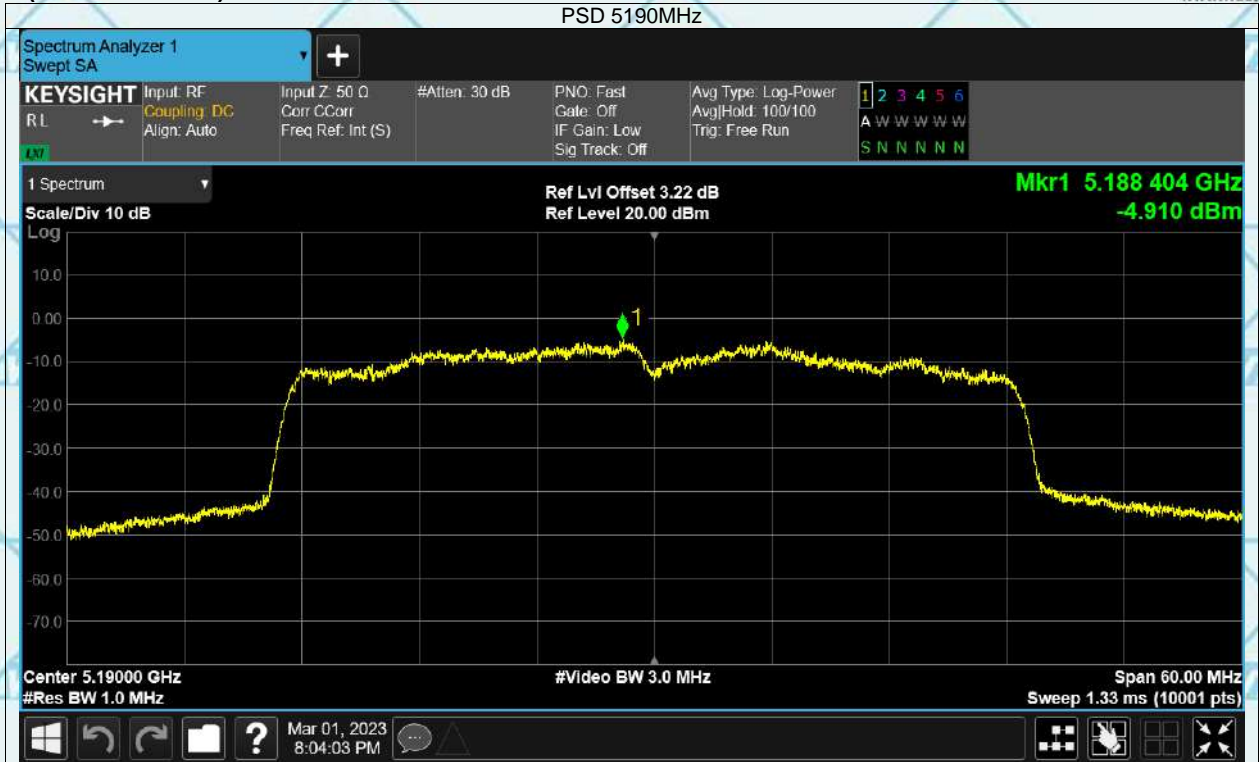

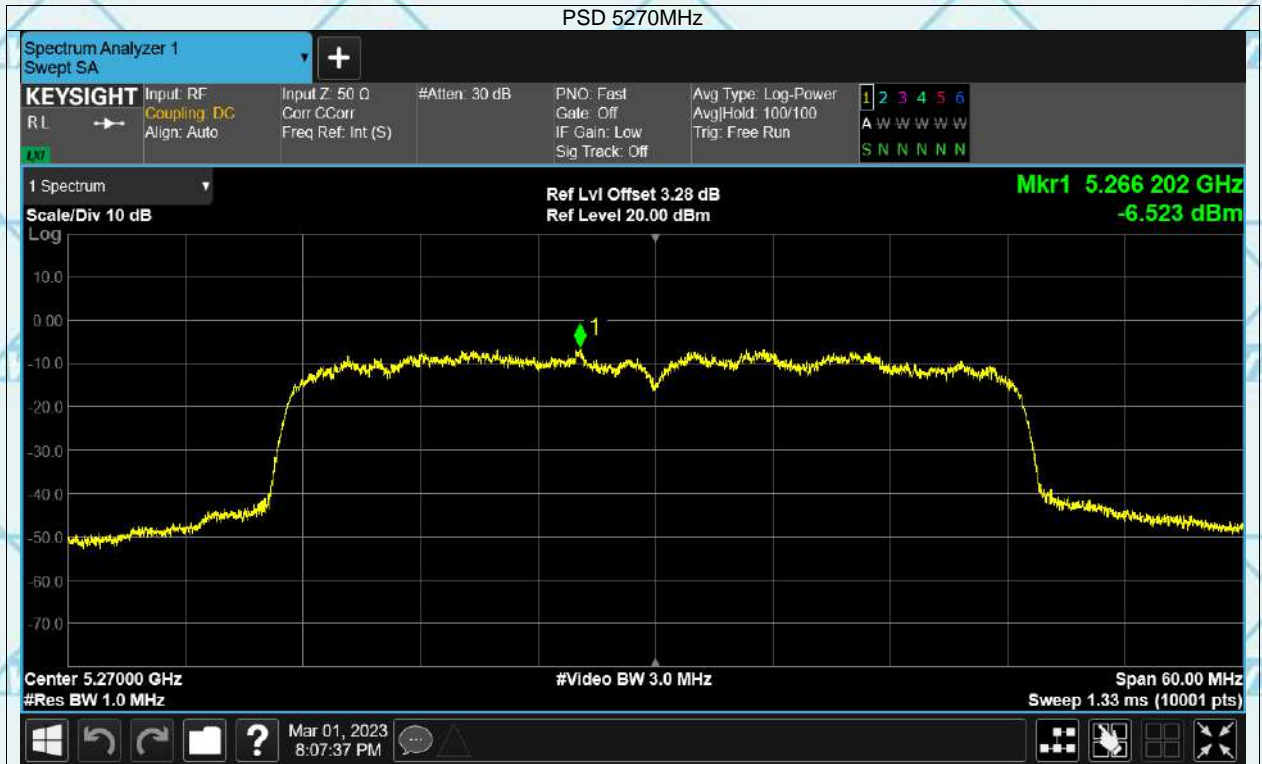

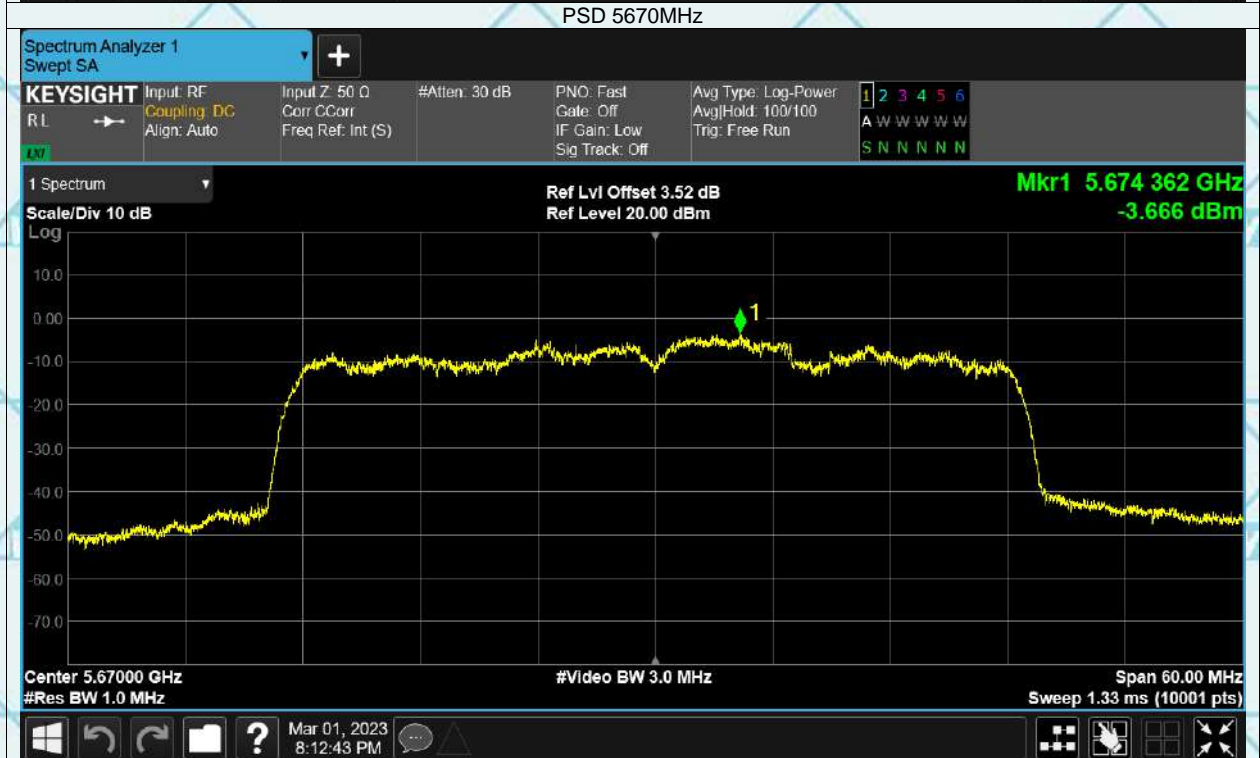
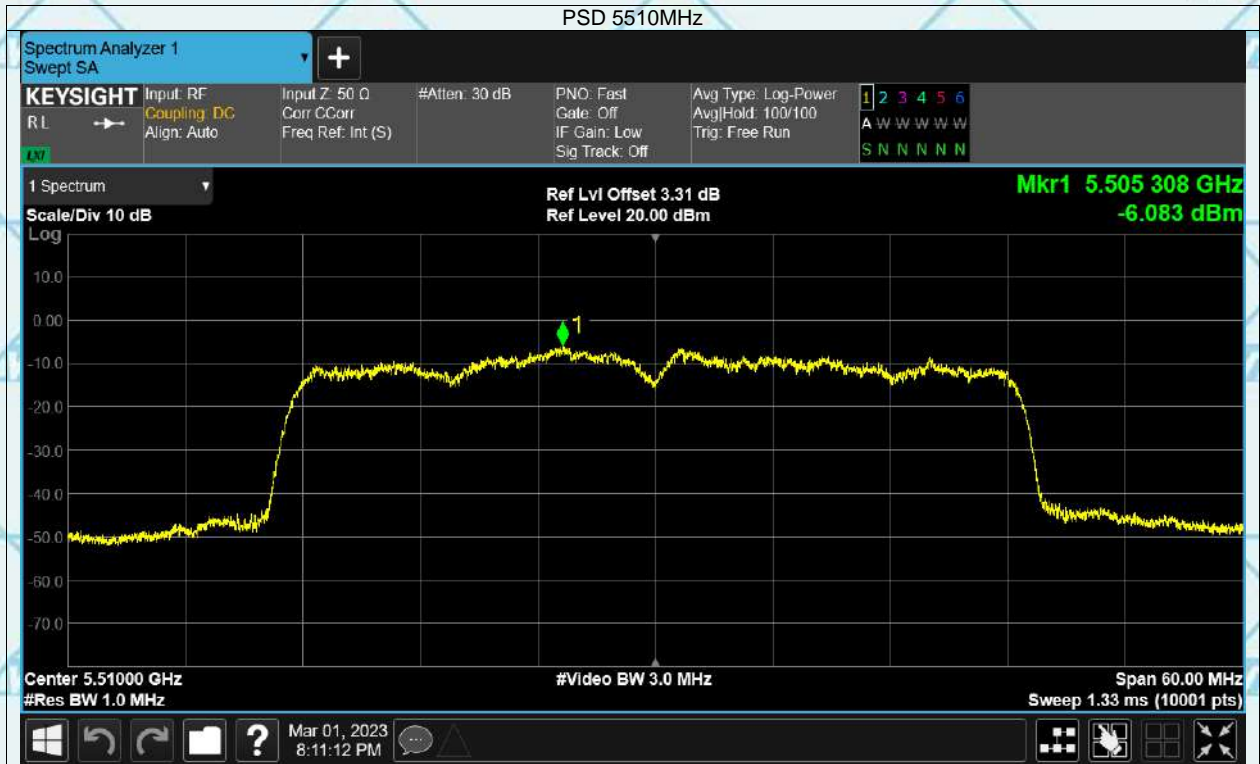



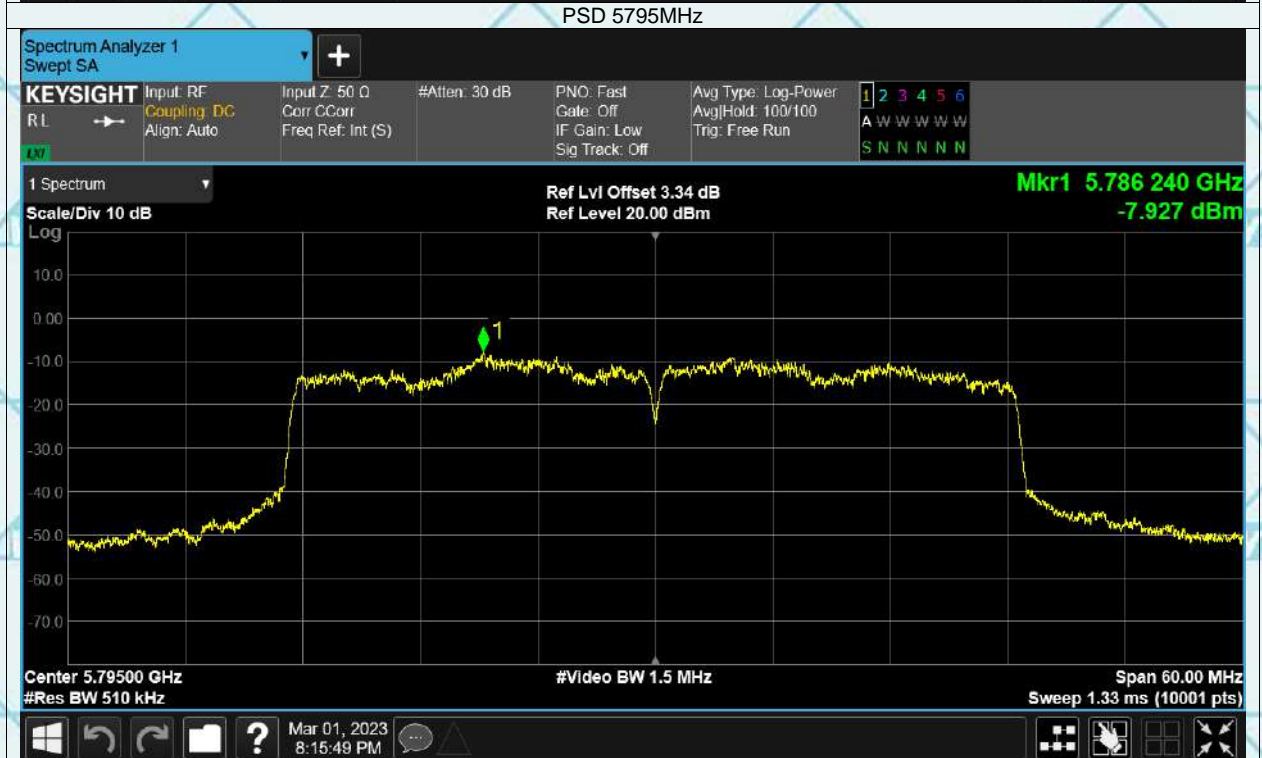
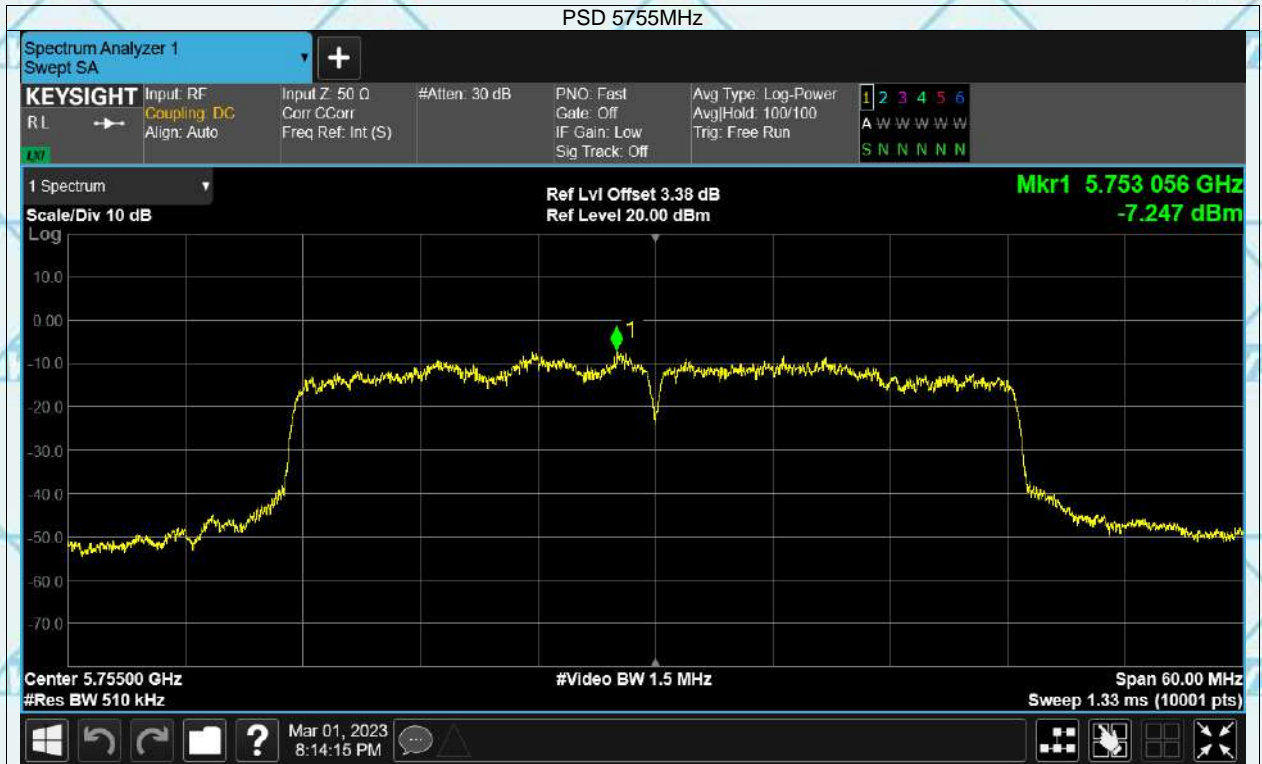



Report No.: WSCT-A2LA-R&E230300002A-Wi-Fi2

Certificate #5768.01

For Question, Please Contact with WSCT www.wsct-cert.com

80MHz(IEEE 802.11ac)

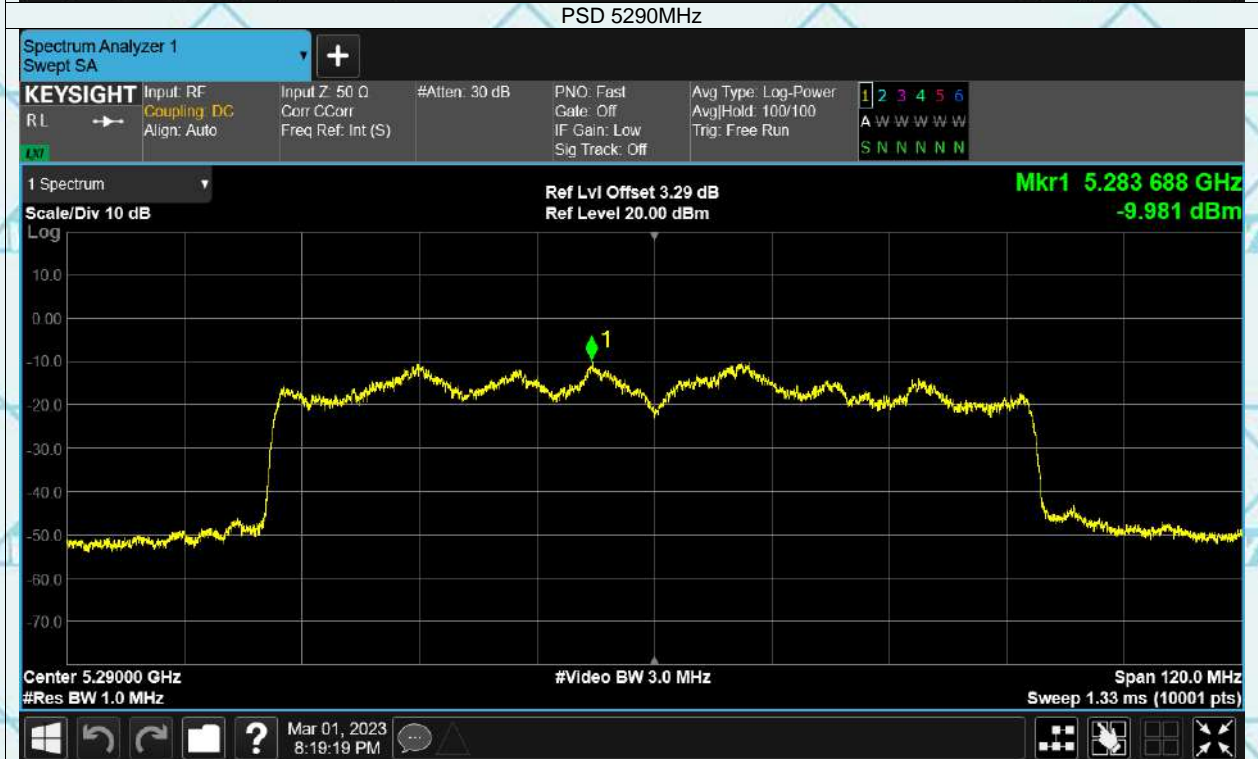



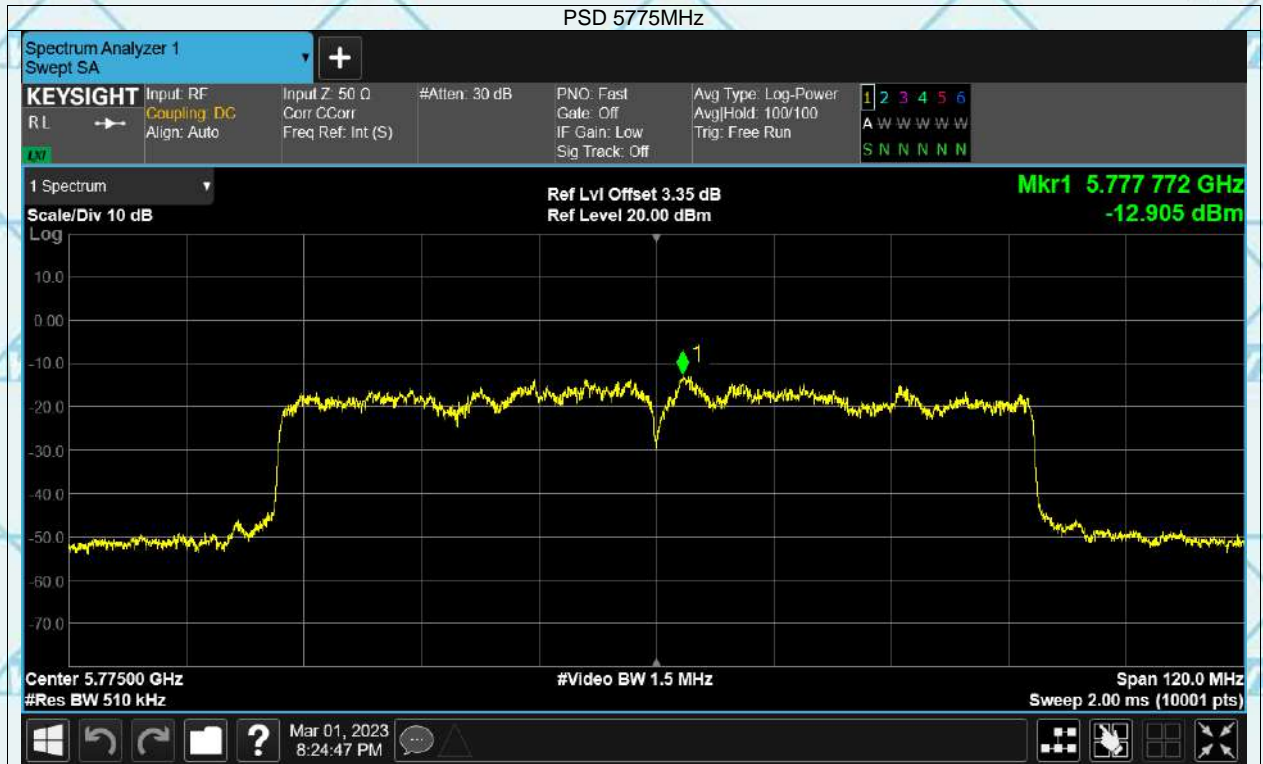



## 7.8 FREQUENCY STABILITY

<b>Product:</b>	EUT-Sample	<b>Test Item:</b>	Frequency Stability
<b>Temperature:</b>	25 °C	<b>Humidity:</b>	56%RH
<b>Test Voltage:</b>	DC 3.8V	<b>Test Result:</b>	PASS

Band	Frequency (MHz)	Measured Frequency (MHz)	Frequency Error (Hz)	Deviation (ppm)	Limit (ppm)	Verdict
20MHz(IEEE 802.11a/n/ac)						
1	5180	5179.98	-20000	-3.86	25	Pass
	5240	5240.02	20000	3.82	25	Pass
2	5260	5259.98	-20000	-3.8	25	Pass
	5320	5320	0	0	25	Pass
3	5500	5499.98	-20000	-3.64	25	Pass
	5700	5699.98	-20000	-3.51	25	Pass
4	5745	5744.98	-20000	-3.48	25	Pass
	5825	5824.98	-20000	-3.43	25	Pass
400MHz(IEEE 802.11n/ac)						
1	5190	5190	0	0	25	Pass
	5230	5229.96	-40000	-7.65	25	Pass
2	5270	5269.96	-40000	-7.59	25	Pass
	5310	5310	0	0	25	Pass
3	5510	5509.96	-40000	-7.26	25	Pass
	5670	5669.96	-40000	-7.05	25	Pass
4	5755	5755	0	0	25	Pass
	5795	5795	0	0	25	Pass
80MHz(IEEE 802.11ac)						
1	5210	5210	0	0	25	Pass
2	5290	5290.08	80000	15.12	25	Pass
3	5530	5529.92	-80000	-14.47	25	Pass
	5610	5609.92	-80000	-14.26	25	Pass
4	5775	5775	0	0	25	Pass





Report No.: WSCT-A2LA-R&E230300002A-Wi-Fi2

Certificate #5768.01

For Question, Please Contact with WSCT  
www.wsct-cert.com

20MHz(IEEE 802.11a/n/ac)  
Band1

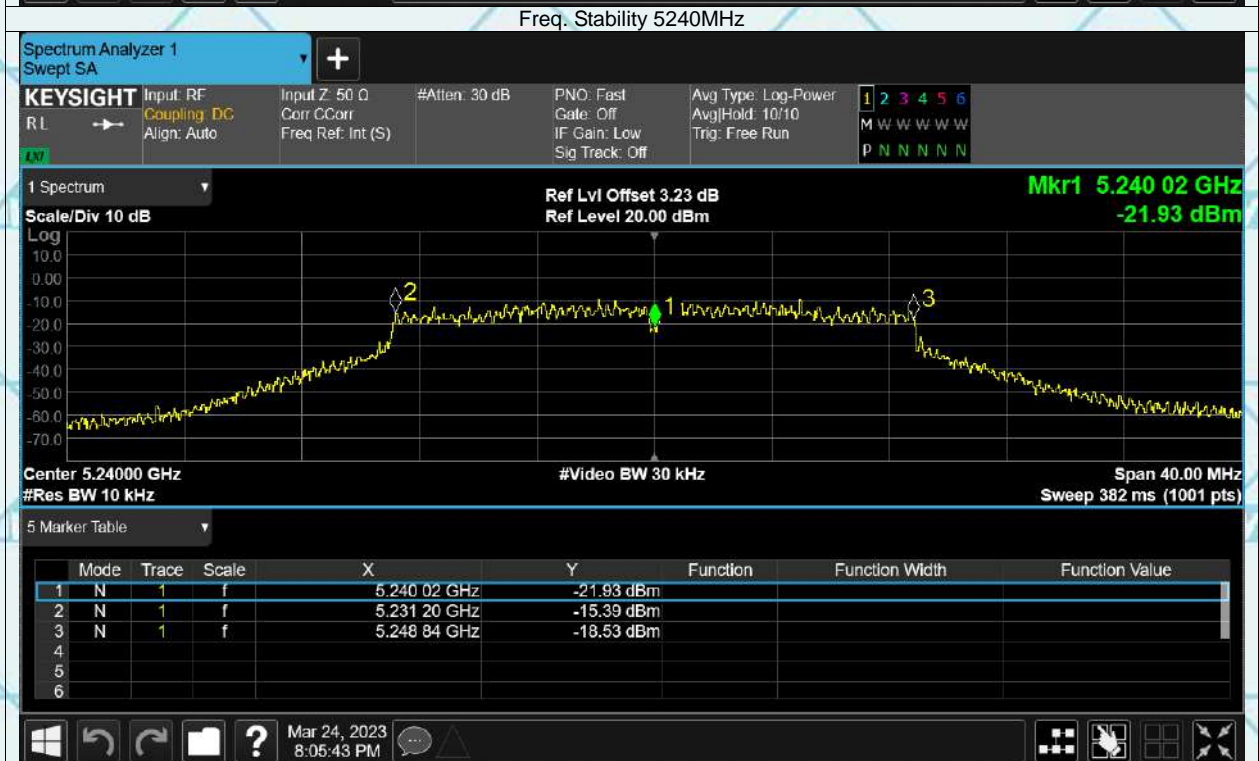
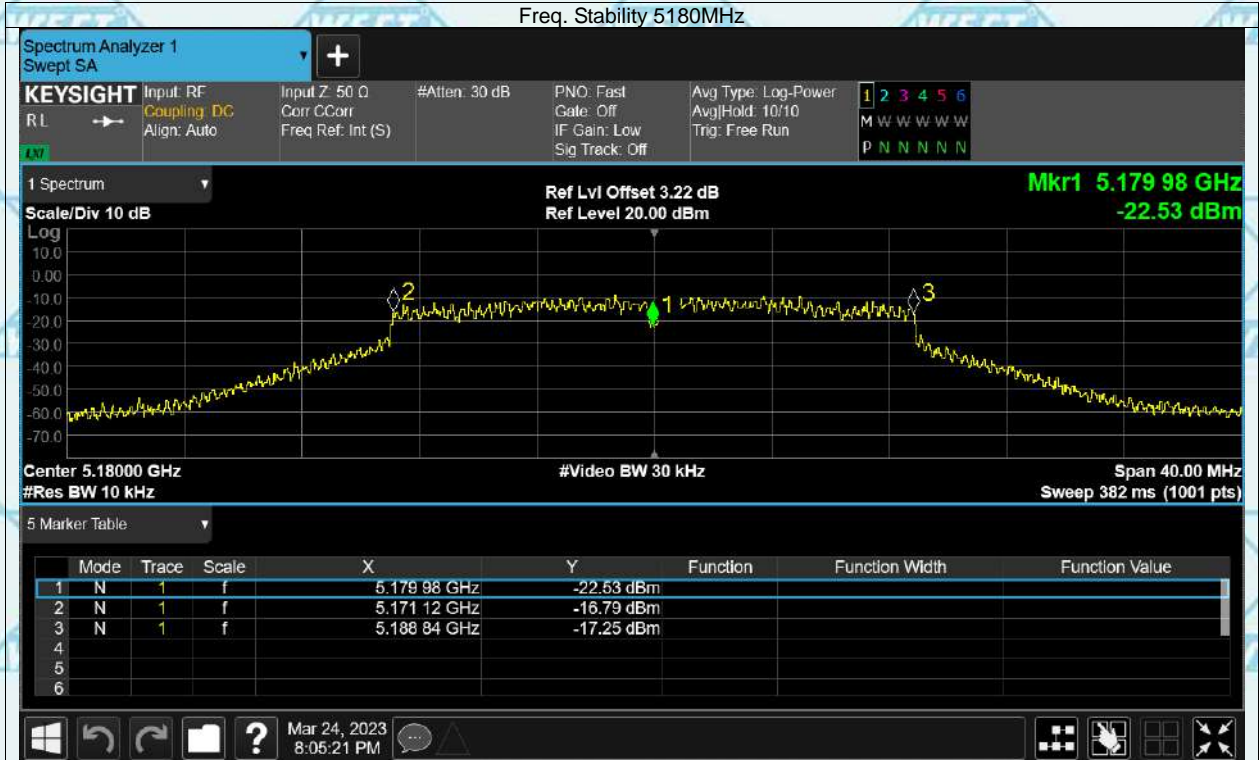



**Band2**

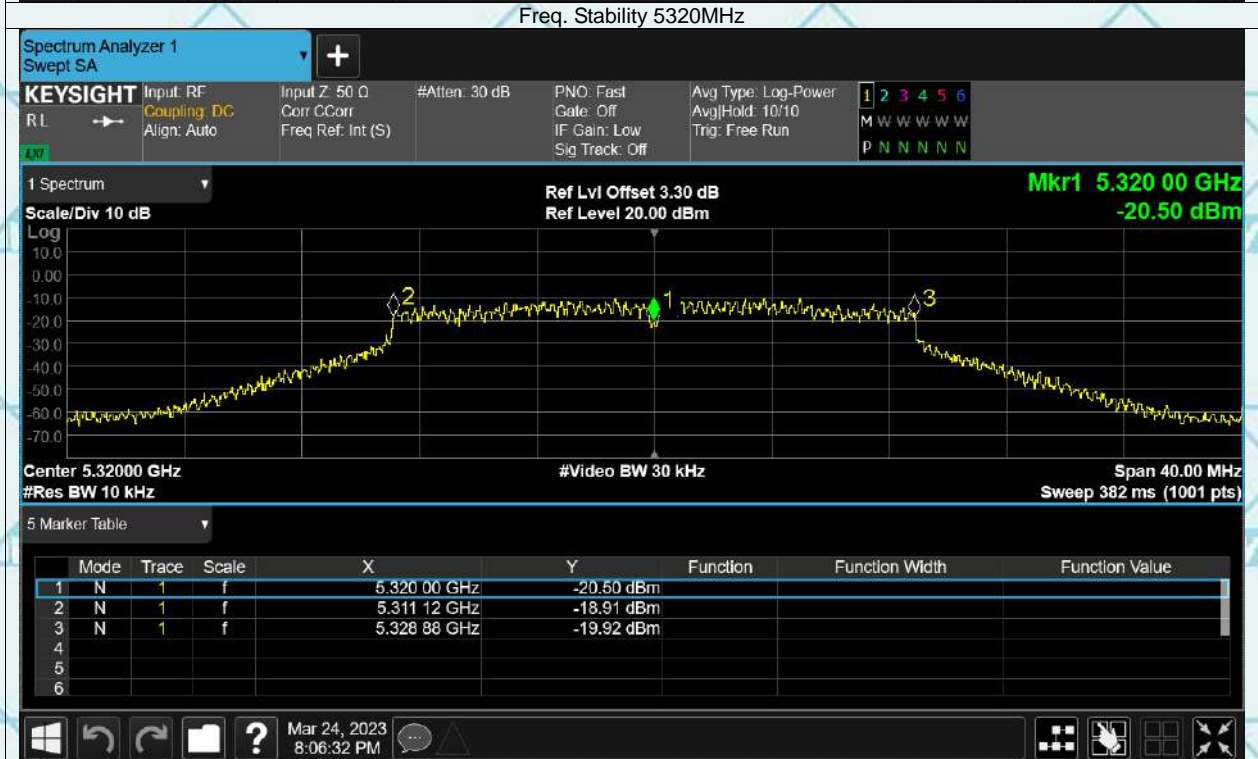



Band3

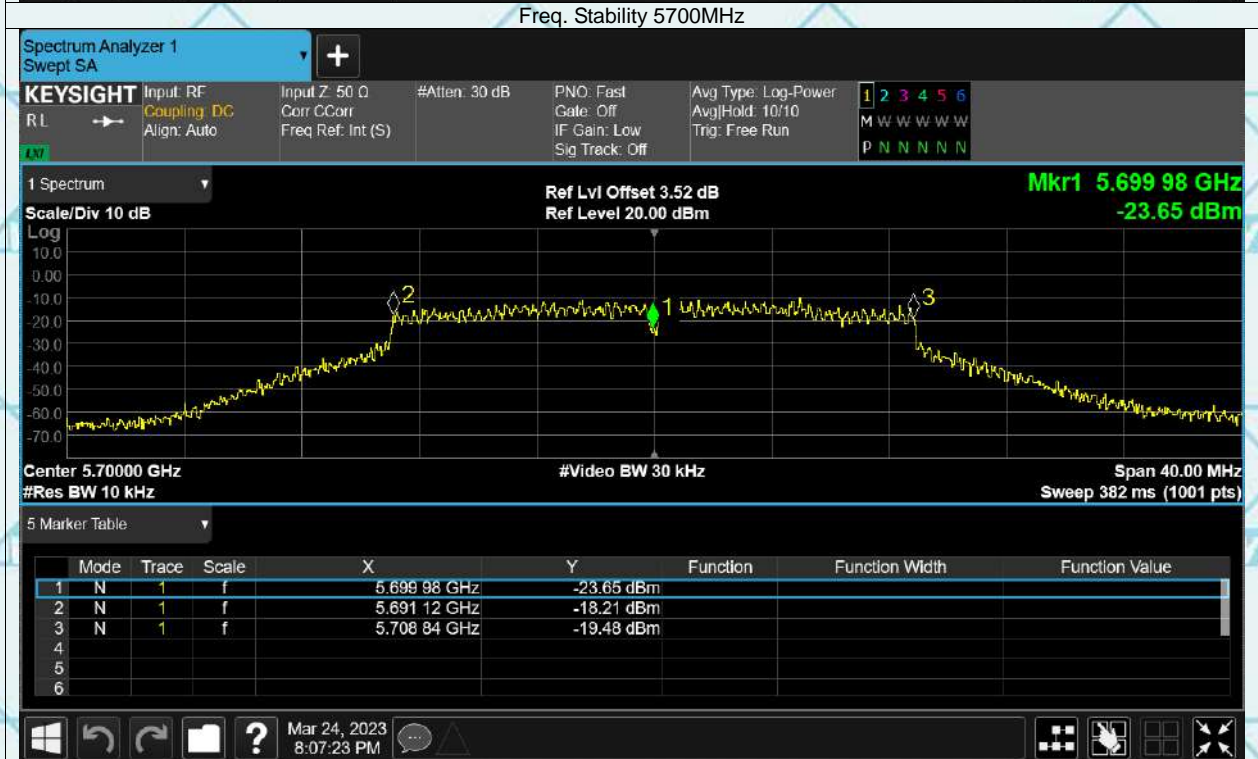





Band4

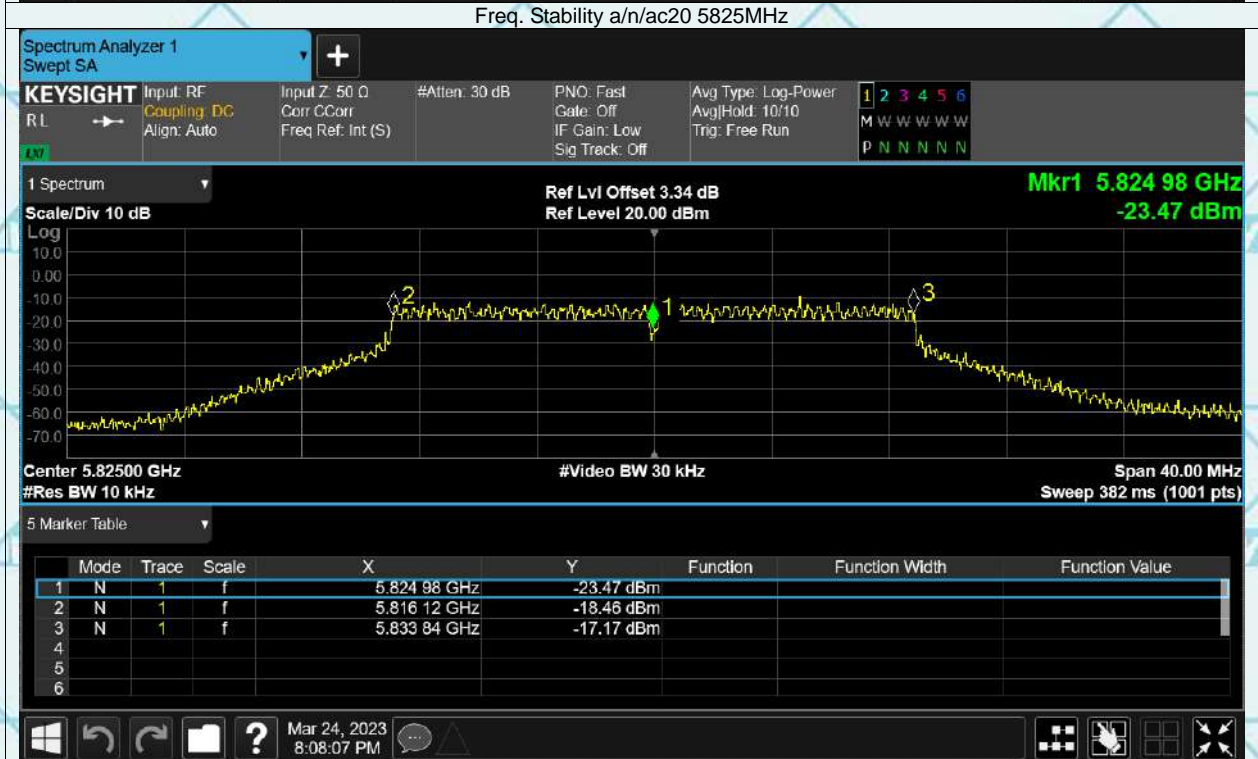
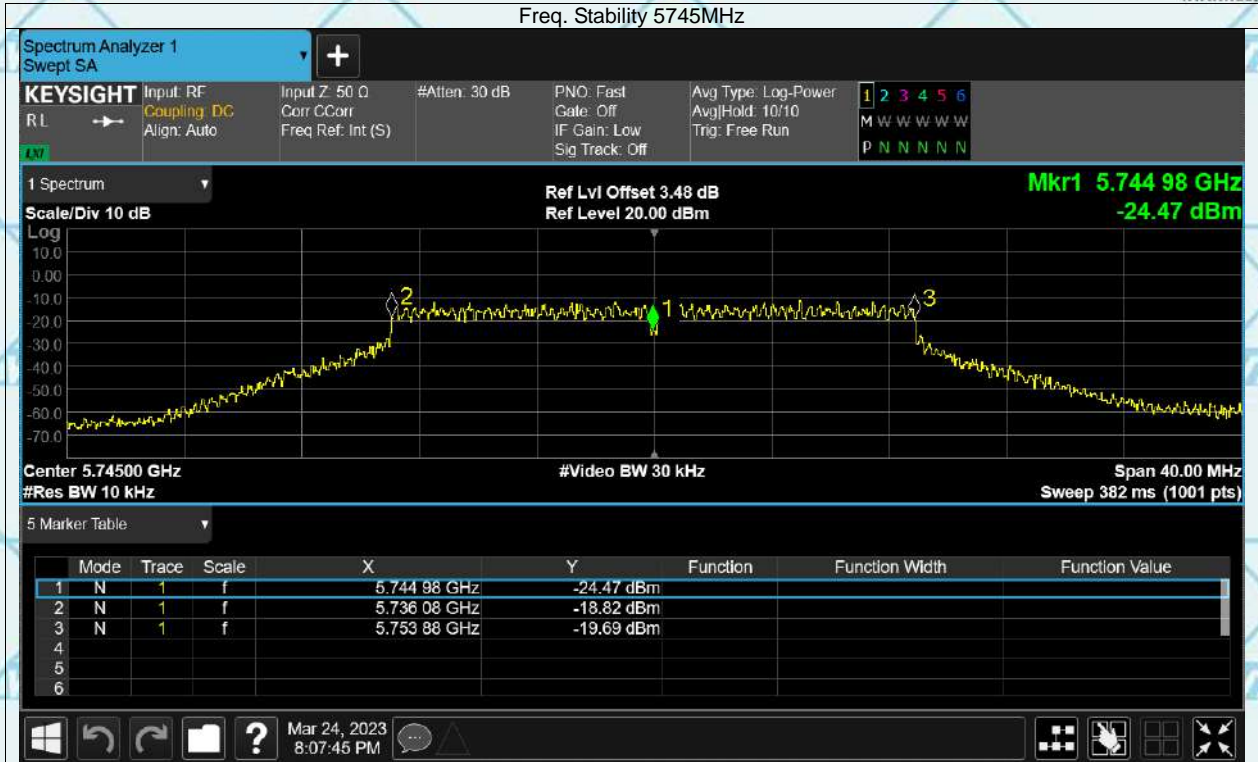



Report No.: WSCT-A2LA-R&E230300002A-Wi-Fi2

Certificate #5768.01

For Question, Please Contact with WSCT  
www.wsct-cert.com

40MHz(IEEE 802.11n/ac)  
Band1

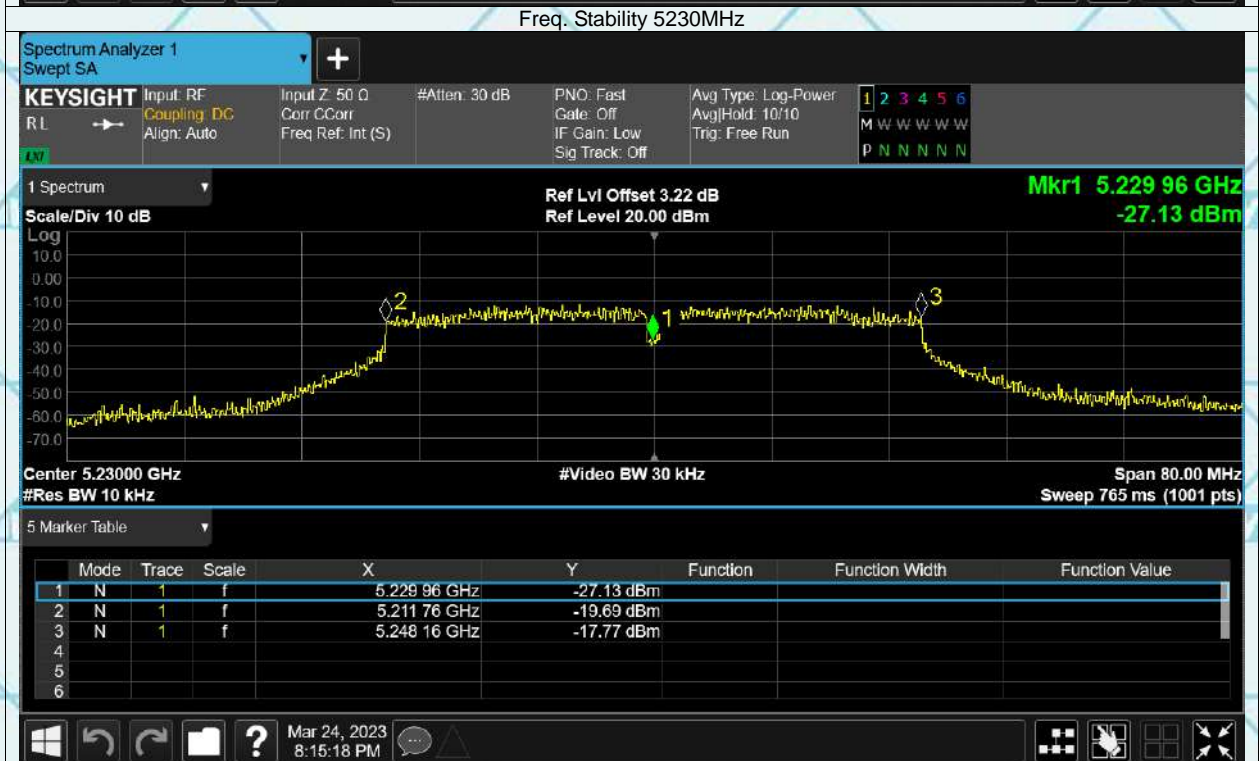
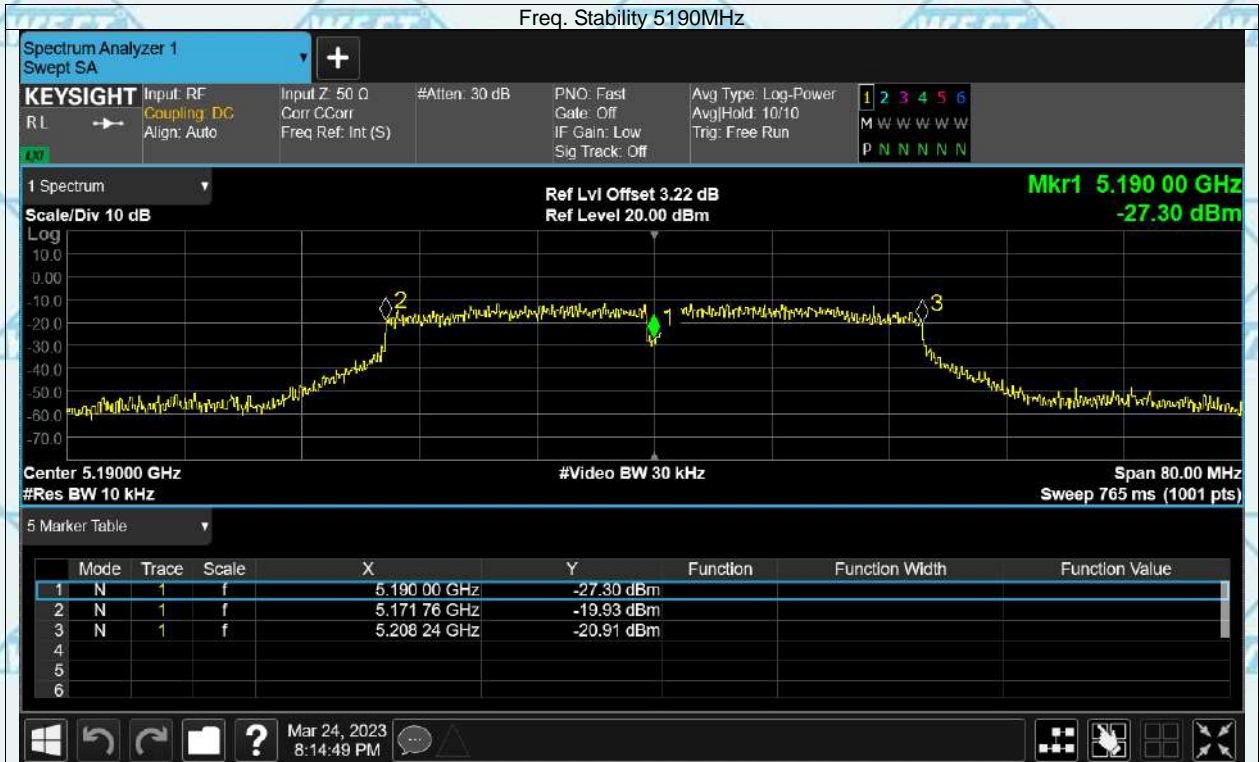



Band2

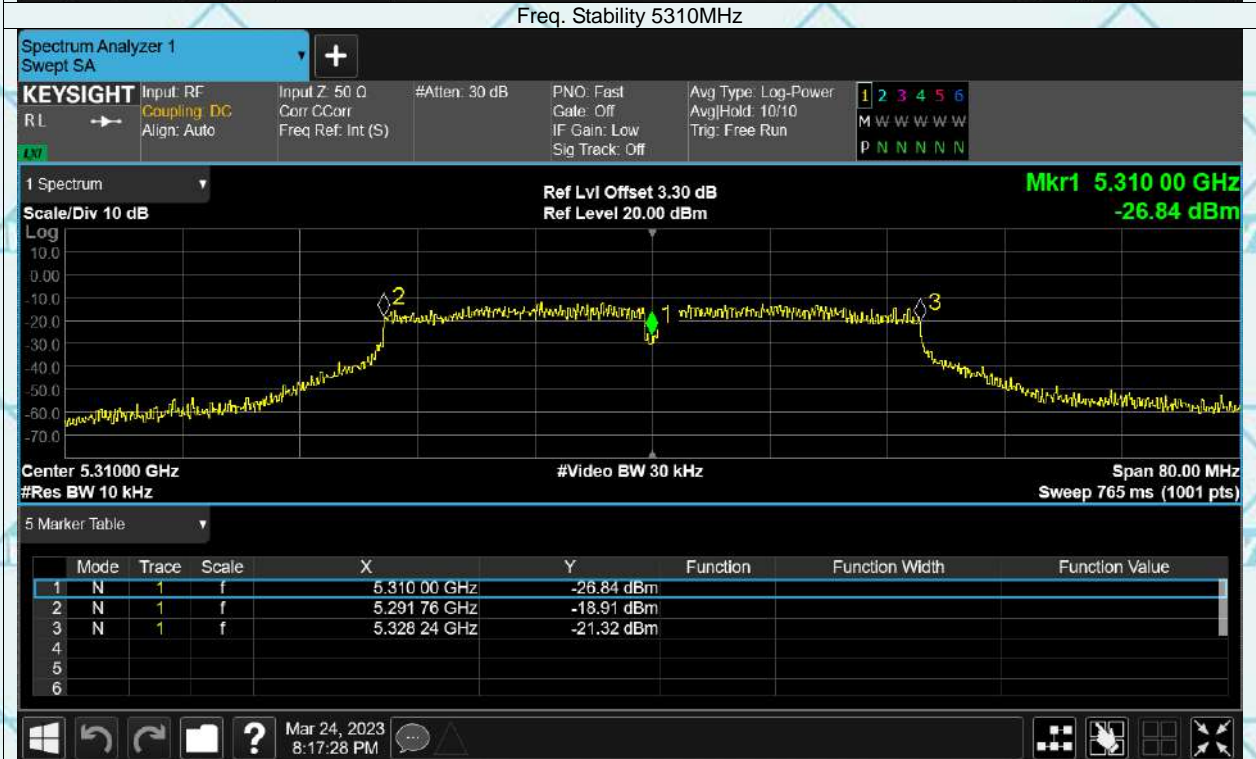



Band3

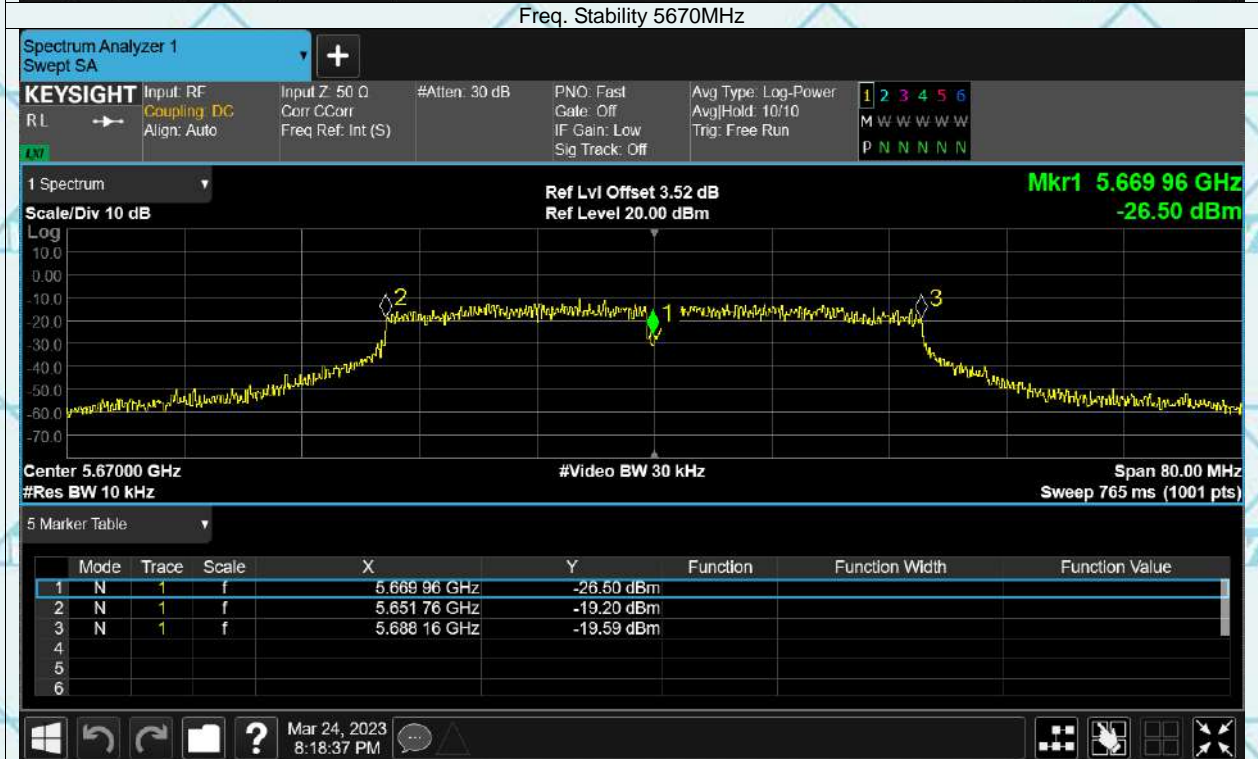



Band4

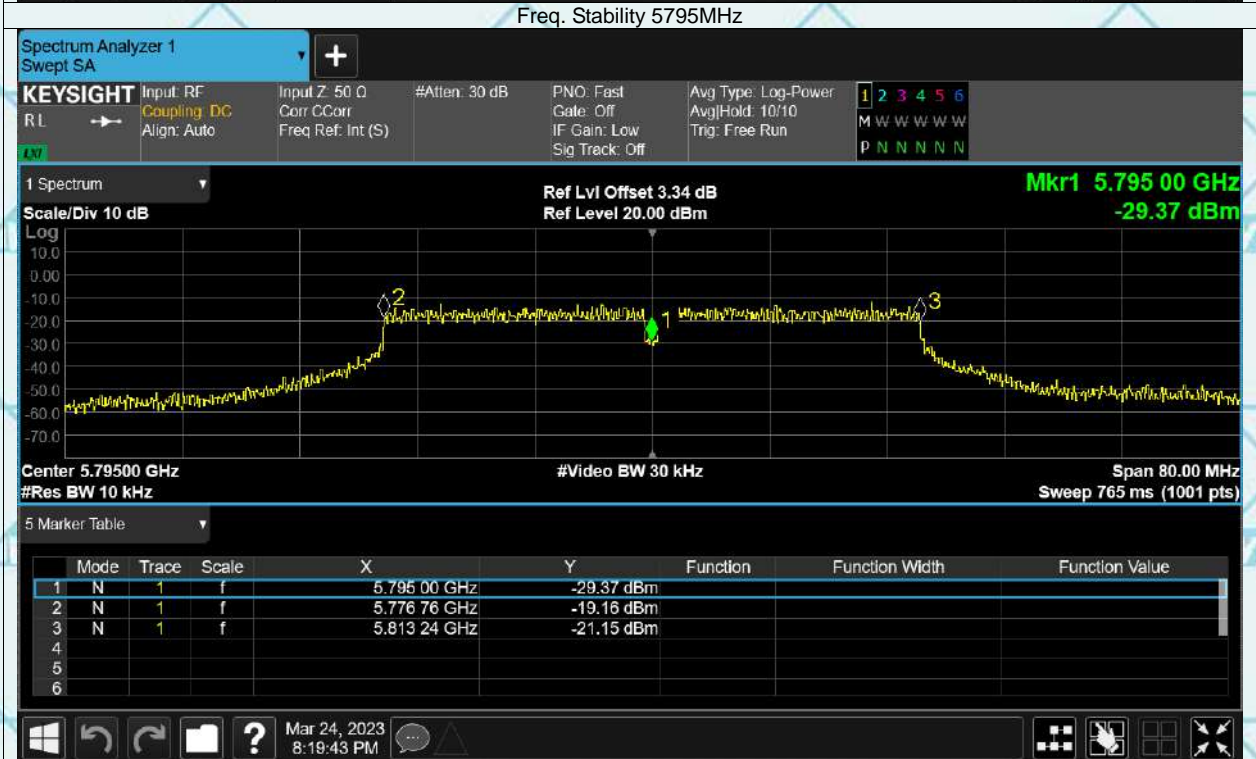
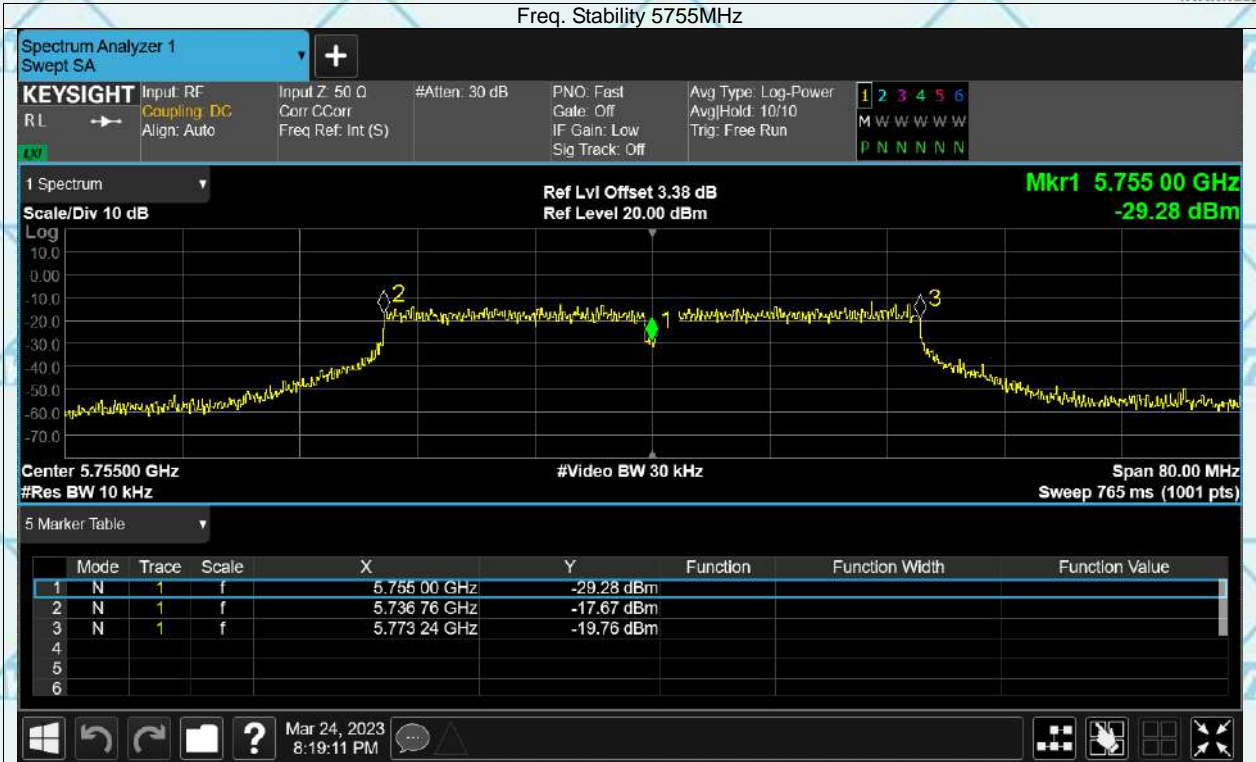



Report No.: WSCT-A2LA-R&E230300002A-Wi-Fi2

Certificate #5768.01

For Question,  
Please Contact with WSCT  
www.wsct-cert.com

**80MHz(IEEE 802.11ac)**  
**Band1**

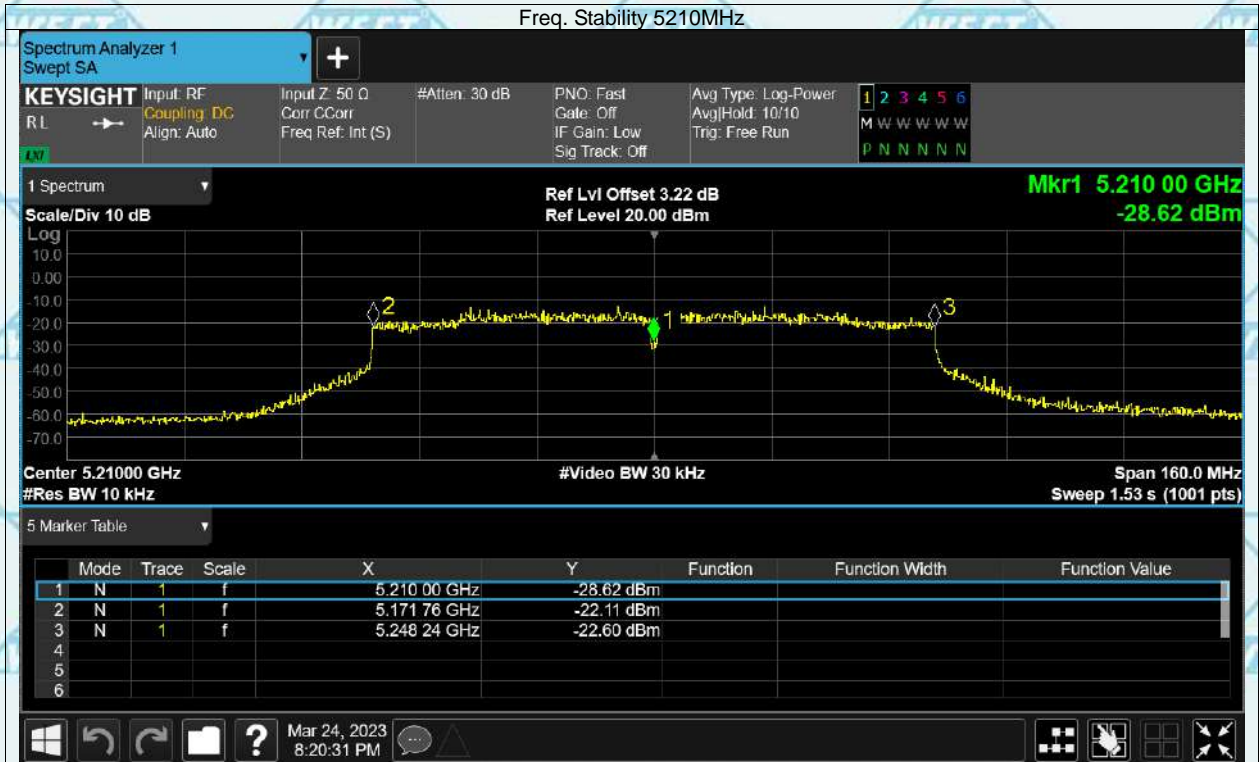

**Band2**





Band3

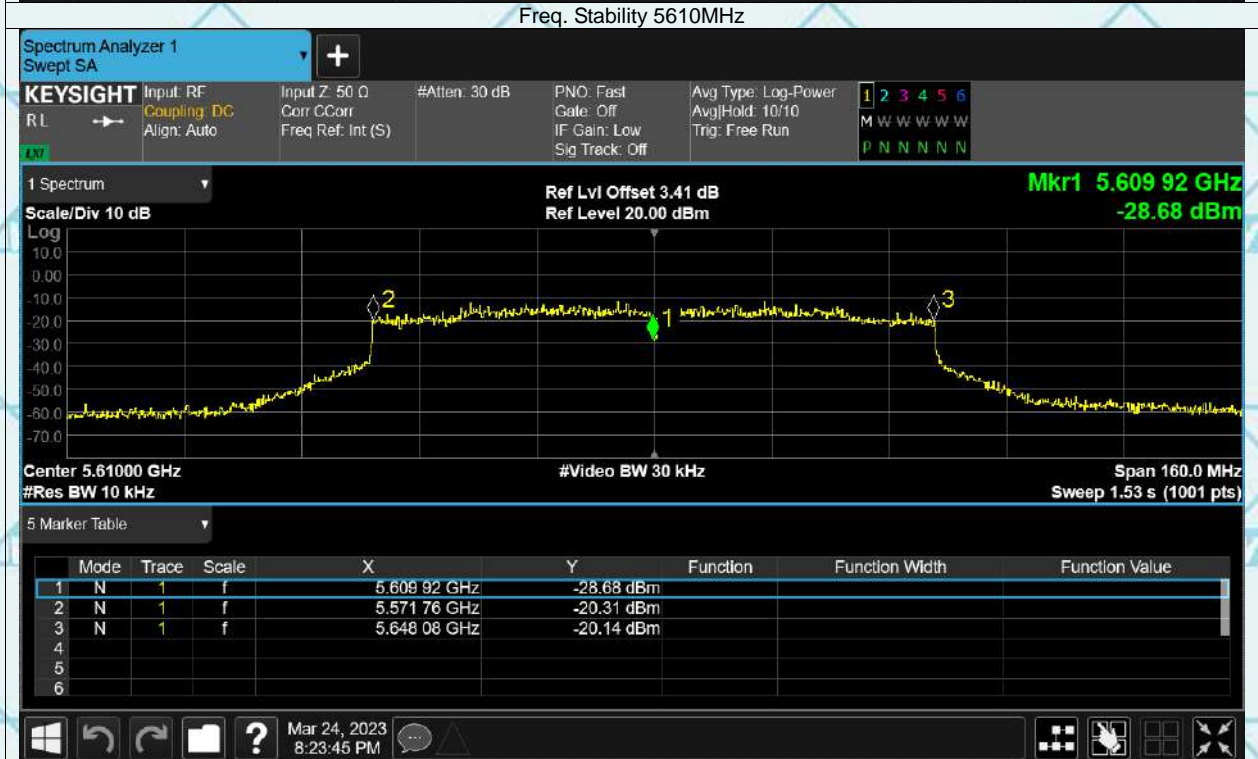
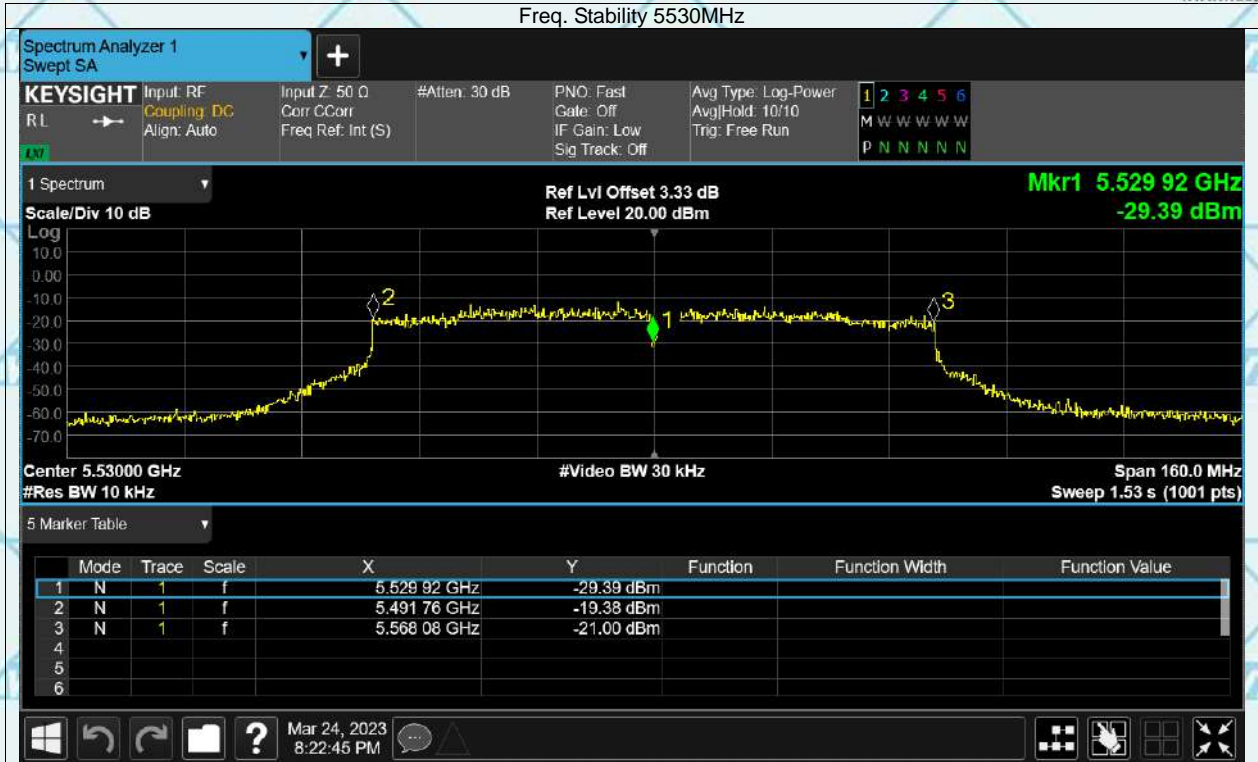



Band4

Freq. Stability 5775MHz







## 7.9 BAND EDGE EMISSIONS

### 7.9.1 TEST EQUIPMENT

Please refer to Section 4 this report.

### 7.9.2 TEST PROCEDURE

<b>Band Edge Emissions Measurement:</b>	
Test Method:	<p>a.)The EUT was tested according to ANSI C63.10.</p> <p>b)The EUT, peripherals were put on the turntable which table size is 1m x 1.5 m, table high 1.5 m. All set up is according to ANSI C63.10.</p> <p>c)The frequency spectrum from 9 kHz to 40 GHz was investigated. All readings from 9 kHz to 150 kHz are quasi-peak values with a resolution bandwidth of 200 Hz. All readings from 150 kHz to 30 MHz are quasi-peak values with a resolution bandwidth of 9 KHz. All readings from 30 MHz to 1 GHz are quasi-peak values with a resolution bandwidth of 120 KHz. All readings are above 1 GHz , peak values with a resolution bandwidth of 1 MHz . Measurements were made at 3 meters.</p> <p>d)The emissions from the EUT were measured continuously at every azimuth by rotating the turntable. The Receiving antenna high is varied from 1 m to 4 m high to find the maximum emission for each frequency. Emissions below 30MHz were measured with a loop antenna while emission above 30MHz were measured using a broadband E-field antenna.</p> <p>e) Maximizing procedure was performed on the six (6) highest emissions to ensure EUT compliance is with all installation combinations. All data was recorded in the peak detection mode. Quasi-peak readings was performed only when an emission was found to be marginal (within -4 dB of specification limit), and are distinguished with a "QP" in the data table.</p> <p>f)Each emission was to be maximized by changing the polarization of receiving antenna both horizontal and vertical. In order to find out the max. emission, the relative positions of this transmitter(EUT) was rotated through three orthogonal axes according to the requirements in Section 8 and 13 of ANSI C63.10.</p>
<b>Band Edge Emissions Measurement:</b>	
Test Equipment Setting:	
<p>a)Attenuation: Auto</p> <p>b)Span Frequency: 100 MHz</p> <p>c)RBW/VBW (Emission in restricted band): 1MHz / 3MHz for Peak, 1MHz / 1/T for Average</p>	<p>d)RBW/VBW(Emission in non-restricted band) 1MHz / 3MHz for peak</p>

### 7.9.3 TEST SETUP

Same as section 3.4 of this report

### 7.9.4 CONFIGURATION OF THE EUT

Same as section 3.4 of this report

### 7.9.5 EUT OPERATING CONDITION

Same as section 3.4 of this report.





### 7.9.6 LIMIT

**Spurious Radiated Emission & Band Edge Emissions Measurement:**

**Limit:** For transmitters operating in the 5.15-5.35 GHz band: all emissions outside of the 5.15-5.35 GHz band shall not exceed an e.i.r.p. of -27 dBm/MHz.  
 For transmitters operating in the 5.470-5.725 GHz band: all emissions outside of the 5.47-5.725 GHz band shall not exceed an e.i.r.p. of -27 dBm/MHz.  
 For transmitters operating in the 5.725-5.85 GHz band: all emissions within the frequency range from the band edge to 10 MHz above or below the band edge shall not exceed an e.i.r.p. of -17 dBm/MHz; for frequencies 10 MHz or greater above or below the band edge, emissions shall not exceed an e.i.r.p. of -27 dBm/MHz.

In any 100 KHz bandwidth outside the operating frequency band, the radio frequency power that is produced by modulation products of the spreading sequence, the information sequence and the carrier frequency shall be either at least 20 dB below that in any 100 KHz bandwidth within the band that contains the highest level of the desired power or shall not exceed the general levels specified in section 15.209(a), which lesser attenuation.

All other emissions inside restricted bands specified in section 15.205(a) shall not exceed the general radiated emission limits specified in section 15.209(a)

**Note:**  
 Applies to harmonics/spurious emissions that fall in the restricted bands listed in section 15.205. The maximum permitted average field strength is listed in section 15.209.  
 47 CFR § 15.237(c): The emission limits as specified above are based on measurement instrument employing an average detector. The provisions in section 15.35 for limiting peak emissions apply.





Report No.: WSCT-A2LA-R&amp;E230300002A-Wi-Fi2

Certificate #5768.01

For Question,  
Please Contact with WSCT  
[www.wsct-cert.com](http://www.wsct-cert.com)

### 7.9.7 TEST RESULT

#### Band Edge and Fundamental Emissions

<b>Product:</b>	EUT-Sample	<b>Test Mode:</b>	20MHzIEEE 802.11a/n/ac
<b>Test Item:</b>	Band Edge and Fundamental Emissions	<b>Temperature:</b>	25 °C
<b>Test Voltage:</b>	DC 3.8V	<b>Humidity:</b>	56%RH
<b>Test Result:</b>	PASS		





Report No.: WSCT-A2LA-R&E230300002A-Wi-Fi2

Certificate #5768.01

For Question,  
Please Contact with WSCT  
www.wsct-cert.com

20MHz(IEEE 802.11a/n/ac)  
Channel Low (5180MHz)



Channel High (5320MHz)

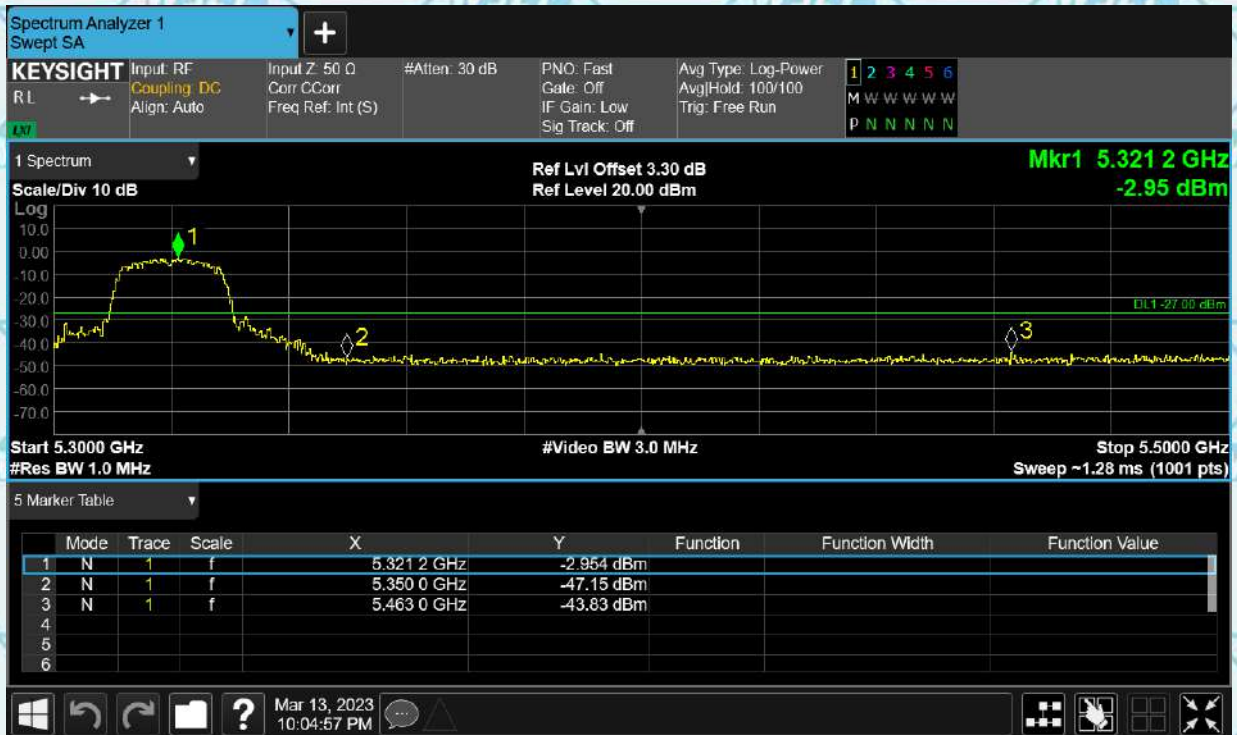



Report No.: WSCT-A2LA-R&E230300002A-Wi-Fi2

Certificate #5768.01

For Question, Please Contact with WSCT  
www.wsct-cert.com

Channel Low (5745MHz)



Channel High (5825MHz)

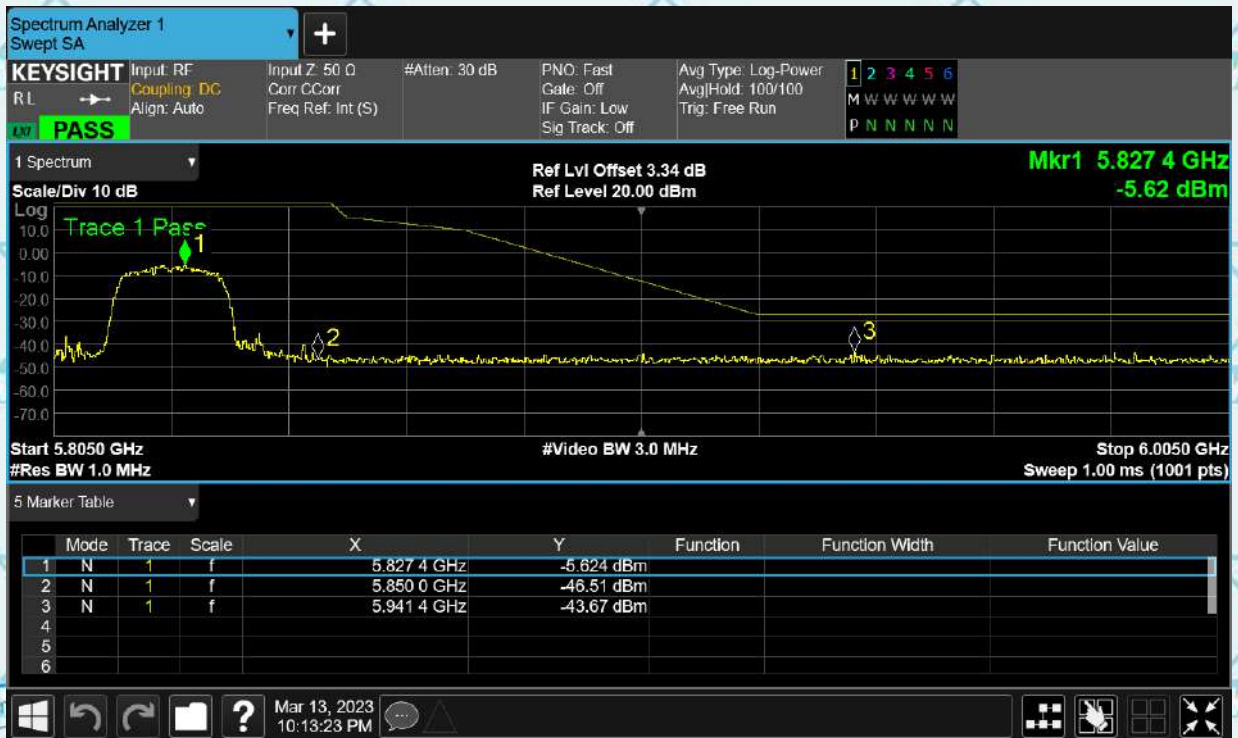



Report No.: WSCT-A2LA-R&E230300002A-Wi-Fi2

Certificate #5768.01

For Question, Please Contact with WSCT  
www.wsct-cert.com

40MHz IEEE 802.11n/ac  
Channel Low (5190MHz)



Channel High (5310MHz)





Report No.: WSCT-A2LA-R&E230300002A-Wi-Fi2

Certificate #5768.01

For Question, Please Contact with WSCT  
www.wsct-cert.com

Channel Low (5755MHz)



Channel High (5795MHz)





Report No.: WSCT-A2LA-R&E230300002A-Wi-Fi2

Certificate #5768.01

For Question, Please Contact with WSCT  
www.wsct-cert.com

80MHz IEEE 802.11ac  
Channel Low (5210MHz)



Channel High (5290MHz)







Report No.: WSCT-A2LA-R&E230300002A-Wi-Fi2

Certificate #5768.01

For Question,  
Please Contact with WSCT  
www.wsct-cert.com

**Channel Low (5775MHz)**





## 7.10 DYNAMIC FREQUENCY SELECTION (DFS)

### 7.10.1 DFS OVERVIEW

A U-NII network will employ a DFS function to detect signals from radar systems and to avoid co-channel operation with these systems. This applies to the 5250-5350 MHz and/or 5470-5725 MHz bands.

Within the context of the operation of the DFS function, a U-NII device will operate in either *Master Mode* or *Client Mode*. U-NII devices operating in *Client Mode* can only operate in a network controlled by a U-NII device operating in *Master Mode*.

Tables 1 and 2 shown below summarize the information contained in sections 5.1.1 and 5.1.2

**Table 1: Applicability of DFS Requirements Prior to Use of a Channel**

Requirement	Operational Mode		
	Master	Client Without Radar Detection	Client With Radar Detection
<i>Non-Occupancy Period</i>	Yes	Not required	Yes
<i>DFS Detection Threshold</i>	Yes	Not required	Yes
<i>Channel Availability Check Time</i>	Yes	Not required	Not required
<i>U-NII Detection Bandwidth</i>	Yes	Not required	Yes

**Table 2: Applicability of DFS requirements during normal operation**

Requirement	Operational Mode	
	Master Device or Client with Radar Detection	Client Without Radar Detection
<i>DFS Detection Threshold</i>	Yes	Not required
<i>Channel Closing Transmission Time</i>	Yes	Yes
<i>Channel Move Time</i>	Yes	Yes
<i>U-NII Detection Bandwidth</i>	Yes	Not required

Additional requirements for devices with multiple bandwidth modes	Master Device or Client with Radar Detection	Client Without Radar Detection
<i>U-NII Detection Bandwidth and Statistical Performance Check</i>	All BW modes must be tested	Not required
<i>Channel Move Time and Channel Closing Transmission Time</i>	Test using widest BW mode available	Test using the widest BW mode available for the link
<i>All other tests</i>	Any single BW mode	Not required

**Note:** Frequencies selected for statistical performance check (Section 7.8.4) should include several frequencies within the radar detection bandwidth and frequencies near the edge of the radar detection bandwidth. For 802.11 devices it is suggested to select frequencies in each of the bonded 20 MHz channels and the channel center frequency.





Report No.: WSCT-A2LA-R&E230300002A-Wi-Fi2

Certificate #5768.01

For Question, Please Contact with WSCT  
www.wsct-cert.com

The operational behavior and individual DFS requirements that are associated with these modes are as follows:

**DFS Detection Thresholds**

**Table 3** below provides the *DFS Detection Thresholds* for *Master Devices* as well as *Client Devices* incorporating *In-Service Monitoring*.

**Table 3: DFS Detection Thresholds for Master Devices and Client Devices with Radar Detection**

Maximum Transmit Power	Value (See Notes 1, 2, and 3)
EIRP ≥ 200 milliwatt	-64 dBm
EIRP < 200 milliwatt and power spectral density < 10 dBm/MHz	-62 dBm
EIRP < 200 milliwatt that do not meet the power spectral density requirement	-64 dBm

**Note 1:** This is the level at the input of the receiver assuming a 0 dBi receive antenna.  
**Note 2:** Throughout these test procedures an additional 1 dB has been added to the amplitude of the test transmission waveforms to account for variations in measurement equipment. This will ensure that the test signal is at or above the detection threshold level to trigger a DFS response.  
**Note 3:** EIRP is based on the highest antenna gain. For MIMO devices refer to KDB Publication 662911 D01.

**Response Requirements**

**Table 4** provides the response requirements for *Master* and *Client Devices* incorporating DFS.

**Table 4: DFS Response Requirement Values**

Parameter	Value
<i>Non-occupancy period</i>	Minimum 30 minutes
<i>Channel Availability Check Time</i>	60 seconds
<i>Channel Move Time</i>	10 seconds See Note 1.
<i>Channel Closing Transmission Time</i>	200 milliseconds + an aggregate of 60 milliseconds over remaining 10 second period. See Notes 1 and 2.
<i>U-NII Detection Bandwidth</i>	Minimum 100% of the U-NII 99% transmission power bandwidth. See Note 3.

**Note 1:** *Channel Move Time* and the *Channel Closing Transmission Time* should be performed with Radar Type 0. The measurement timing begins at the end of the Radar Type 0 burst.  
**Note 2:** The *Channel Closing Transmission Time* is comprised of 200 milliseconds starting at the beginning of the *Channel Move Time* plus any additional intermittent control signals required to facilitate a *Channel move* (an aggregate of 60 milliseconds) during the remainder of the 10 second period. The aggregate duration of control signals will not count quiet periods in between transmissions.  
**Note 3:** During the *U-NII Detection Bandwidth* detection test, radar type 0 should be used. For each frequency step the minimum percentage of detection is 90 percent. Measurements are performed with no data traffic.





## RADAR TEST WAVEFORMS

This section provides the parameters for required test waveforms, minimum percentage of successful detections, and the minimum number of trials that must be used for determining DFS conformance. Step intervals of 0.1 microsecond for Pulse Width, 1 microsecond for PRI, 1 MHz for chirp width and 1 for the number of pulses will be utilized for the random determination of specific test waveforms.

### Short Pulse Radar Test Waveforms

Table 5 – Short Pulse Radar Test Waveforms

Radar Type	Pulse Width (μsec)	PRI (μsec)	Number of Pulses	Minimum Percentage of Successful Detection	Minimum Number of Trials
0	1	1428	18	See Note 1	See Note 1
1	1	Test A: 15 unique PRI values randomly selected from the list of 23 PRI values in Table 5a	Roundup $\left\{ \left( \frac{1}{360} \right) \cdot \left( \frac{19 \cdot 10^6}{PRI_{\mu sec}} \right) \right\}$	60%	30
		Test B: 15 unique PRI values randomly selected within the range of 518-3066 μsec, with a minimum increment of 1 μsec, excluding PRI values selected in Test A			
2	1-5	150-230	23-29	60%	30
3	6-10	200-500	16-18	60%	30
4	11-20	200-500	12-16	60%	30
Aggregate (Radar Types 1-4)				80%	120
<b>Note 1:</b> Short Pulse Radar Type 0 should be used for the detection bandwidth test, channel move time, and channel closing time tests.					

A minimum of 30 unique waveforms are required for each of the Short Pulse Radar Types 2 through 4. If more than 30 waveforms are used for Short Pulse Radar Types 2 through 4, then each additional waveform must also be unique and not repeated from the previous waveforms. If more than 30 waveforms are used for Short Pulse Radar Type 1, then each additional waveform is generated with Test B and must also be unique and not repeated from the previous waveforms in Tests A or B.

For example if in Short Pulse Radar Type 1 Test B a PRI of 3066 μsec is selected, the number of pulses would be

$$\text{Roundup} \left\{ \left( \frac{1}{360} \right) \cdot \left( \frac{19 \cdot 10^6}{3066} \right) \right\} = \text{Round up } \{ 17.2 \} = 18.$$



**Table 5a - Pulse Repetition Intervals Values for Test A**

Pulse Repetition Frequency Number	Pulse Repetition Frequency (Pulses Per Second)	Pulse Repetition Interval (Microseconds)
1	1930.5	518
2	1858.7	538
3	1792.1	558
4	1730.1	578
5	1672.2	598
6	1618.1	618
7	1567.4	638
8	1519.8	658
9	1474.9	678
10	1432.7	698
11	1392.8	718
12	1355	738
13	1319.3	758
14	1285.3	778
15	1253.1	798
16	1222.5	818
17	1193.3	838
18	1165.6	858
19	1139	878
20	1113.6	898
21	1089.3	918
22	1066.1	938
23	326.2	3066

The aggregate is the average of the percentage of successful detections of Short Pulse Radar Types 1-4. For example, the following table indicates how to compute the aggregate of percentage of successful detections.

Radar Type	Number of Trials	Number of Successful Detections	Minimum Percentage of Successful Detection
1	35	29	82.9%
2	30	18	60%
3	30	27	90%
4	50	44	88%
<b>Aggregate (82.9% + 60% + 90% + 88%)/4 = 80.2%</b>			





## Long Pulse Radar Test Waveform

**Table 6 – Long Pulse Radar Test Waveform**

Radar Type	Pulse Width (µsec)	Chirp Width (MHz)	PRI (µsec)	Number of Pulses per Burst	Number of Bursts	Minimum Percentage of Successful Detection	Minimum Number of Trials
5	50-100	5-20	1000-2000	1-3	8-20	80%	30

The parameters for this waveform are randomly chosen. Thirty unique waveforms are required for the Long Pulse Radar Type waveforms. If more than 30 waveforms are used for the Long Pulse Radar Type waveforms, then each additional waveform must also be unique and not repeated from the previous waveforms.

Each waveform is defined as follows:

- 1) The transmission period for the Long Pulse Radar test signal is 12 seconds.
- 2) There are a total of 8 to 20 *Bursts* in the 12 second period, with the number of *Bursts* being randomly chosen. This number is *Burst Count*.
- 3) Each *Burst* consists of 1 to 3 pulses, with the number of pulses being randomly chosen. Each *Burst* within the 12 second sequence may have a different number of pulses.
- 4) The pulse width is between 50 and 100 microseconds, with the pulse width being randomly chosen. Each pulse within a *Burst* will have the same pulse width. Pulses in different *Bursts* may have different pulse widths.
- 5) Each pulse has a linear frequency modulated chirp between 5 and 20 MHz, with the chirp width being randomly chosen. Each pulse within a *transmission period* will have the same chirp width. The chirp is centered on the pulse. For example, with a radar frequency of 5300 MHz and a 20 MHz chirped signal, the chirp starts at 5290 MHz and ends at 5310 MHz.
- 6) If more than one pulse is present in a *Burst*, the time between the pulses will be between 1000 and 2000 microseconds, with the time being randomly chosen. If three pulses are present in a *Burst*, the random time interval between the first and second pulses is chosen independently of the random time interval between the second and third pulses.
- 7) The 12 second transmission period is divided into even intervals. The number of intervals is equal to *Burst Count*. Each interval is of length  $(12,000,000 / \textit{Burst Count})$  microseconds. Each interval contains one *Burst*. The start time for the *Burst*, relative to the beginning of the interval, is between 1 and  $[(12,000,000 / \textit{Burst Count}) - (\textit{Total Burst Length}) + (\textit{One Random PRI Interval})]$  microseconds, with the start time being randomly chosen. The step interval for the start time is 1 microsecond. The start time for each *Burst* is chosen randomly.

### A representative example of a Long Pulse Radar Type waveform:

- 1) The total test waveform length is 12 seconds.
- 2) Eight (8) *Bursts* are randomly generated for the *Burst Count*.

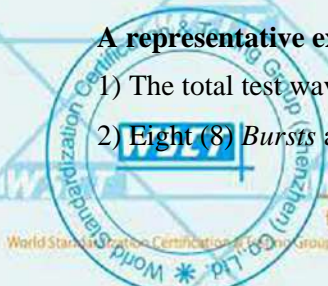



Report No.: WSCT-A2LA-R&E230300002A-Wi-Fi2

- 3) *Burst 1* has 2 randomly generated pulses.
- 4) The pulse width (for both pulses) is randomly selected to be 75 microseconds.
- 5) The PRI is randomly selected to be at 1213 microseconds.
- 6) *Bursts 2* through 8 are generated using steps 3 – 5.
- 7) Each *Burst* is contained in even intervals of 1,500,000 microseconds. The starting location for Pulse 1, *Burst 1* is randomly generated (1 to 1,500,000 minus the total *Burst 1* length + 1 random

PRI interval) at the 325,001 microsecond step. *Bursts 2* through 8 randomly fall in successive 1,500,000 microsecond intervals (i.e. *Burst 2* falls in the 1,500,001 – 3,000,000 microsecond range).

**Figure 1** provides a graphical representation of the Long Pulse Radar Test Waveform.

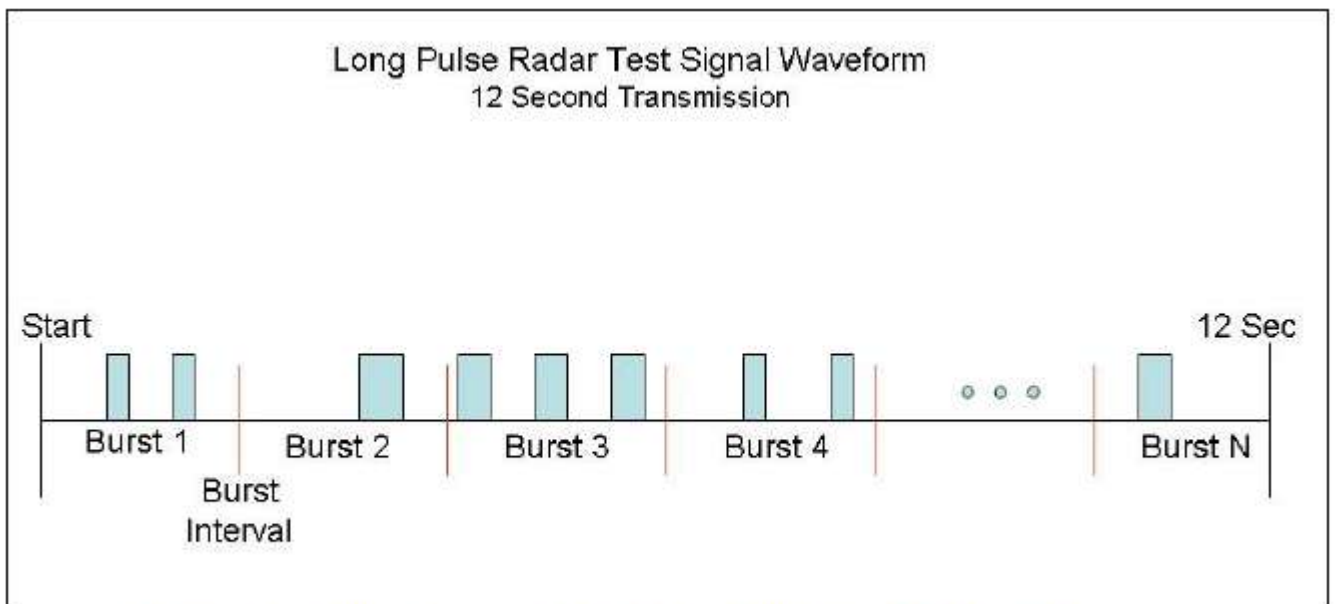

*Figure 1: Graphical Representation of a Long Pulse Radar Type Waveform*





### Frequency Hopping Radar Test Waveform

**Table 7 – Frequency Hopping Radar Test Waveform**

Radar Type	Pulse Width (μsec)	PRI (μsec)	Pulses per Hop	Hopping Rate (kHz)	Hopping Sequence Length (msec)	Minimum Percentage of Successful Detection	Minimum Number of Trials
6	1	333	9	0.333	300	70%	30

For the Frequency Hopping Radar Type, the same *Burst* parameters are used for each waveform. The hopping sequence is different for each waveform and a 100-length segment is selected from the hopping sequence defined by the following algorithm: 4

The first frequency in a hopping sequence is selected randomly from the group of 475 integer frequencies from 5250 – 5724 MHz. Next, the frequency that was just chosen is removed from the group and a frequency is randomly selected from the remaining 474 frequencies in the group. This process continues until all 475 frequencies are chosen for the set. For selection of a random frequency, the frequencies remaining within the group are always treated as equally likely.







7.10.2 TEST PROCEDURE

DFS MEASUREMENT SYSTEM

A complete DFS Measurement System consists of two subsystems:

- (1) The Radar Signal Generating Subsystem and
- (2) The Traffic Monitoring Subsystem.

The control PC is necessary for generating the Radar waveforms in Table 10, 11 and 12. The traffic monitoring subsystem is specified to the type of unit under test (UUT).

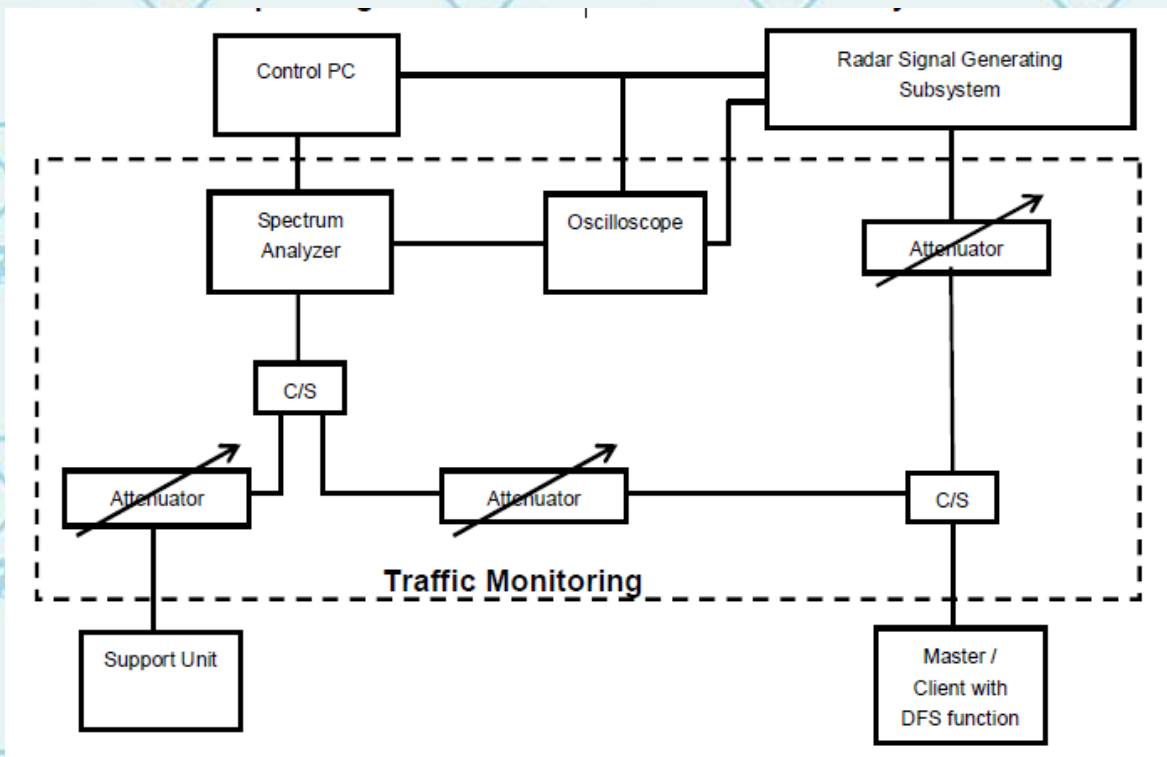

The test transmission will always be from the Master Device to the Client Device. While the Client device is set up to associate with the Master device and play the MPEG file (6 y Magic Hours) from Master device, the designated MPEG test file and instructions are located at: <http://ntiacsd.ntia.doc.gov/dfs/>.





**CALIBRATION OF DFS DETECTION THRESHOLD LEVEL**

The measured channel is 5260MHz. The radar signal was the same as transmitted channels, and injected into the antenna port of Client Device with Radar Detection, measured the channel closing transmission time and channel move time.

**SLAVE WITHOUT RADAR DETECTION MODE**

The antenna gain is -4dBi and required detection threshold is -65dBm (= -62 +1 - 4)dBm. The calibrated conducted detection threshold level is set to -65dBm.

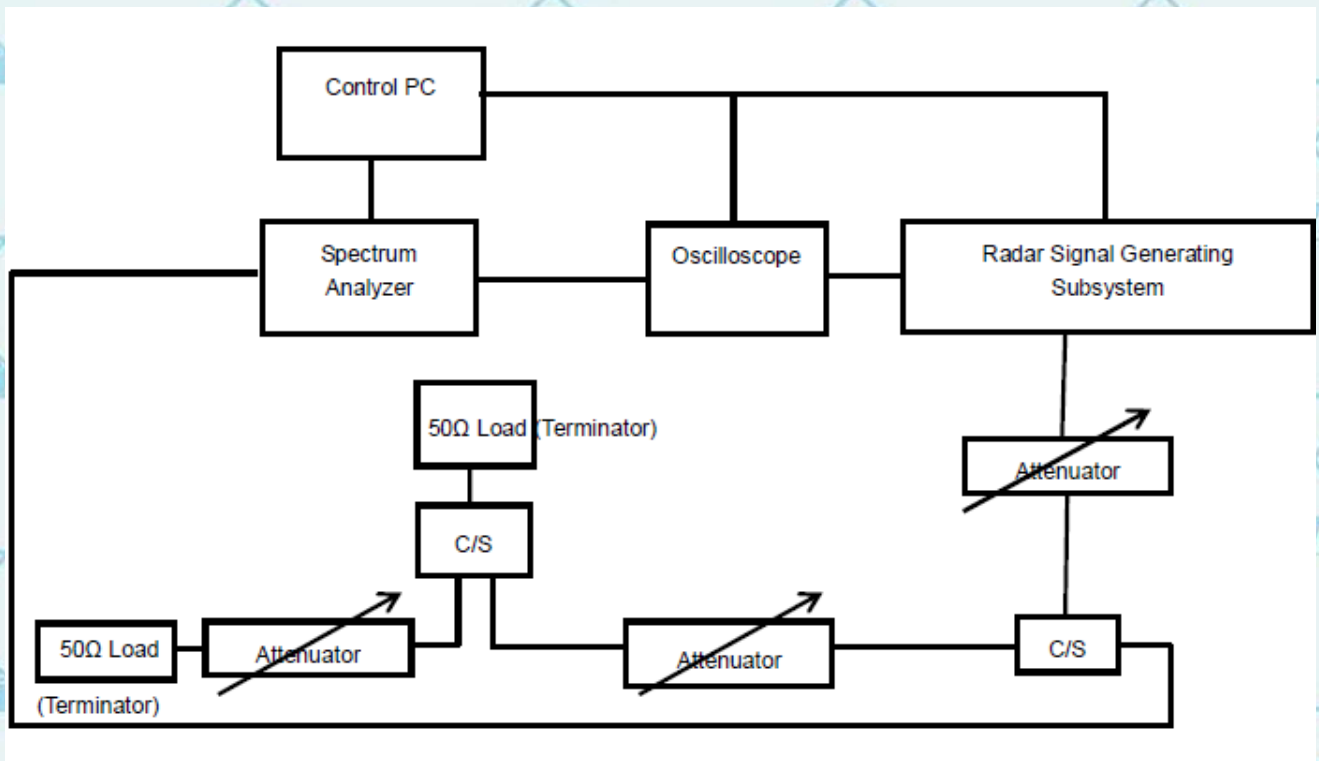

**DEVIATION FROM TEST STANDARD**

No deviation.





### 7.10.3 TEST RESULT

Test Items	Remark	Result
Channel Closing Transmission Time	Applicable	PASS
Channel Move Time	Applicable	PASS

Note: This phone can only be used as a slave without radar detection function.

#### Measurement Record (the worst case)

Measurement data below:

5320MHz			
Test Items	Value (s)	Limit (s)	Test Result
Channel Closing Transmission Time	0.0296	1	Pass
Channel Move Time	0.8582	10	Pass

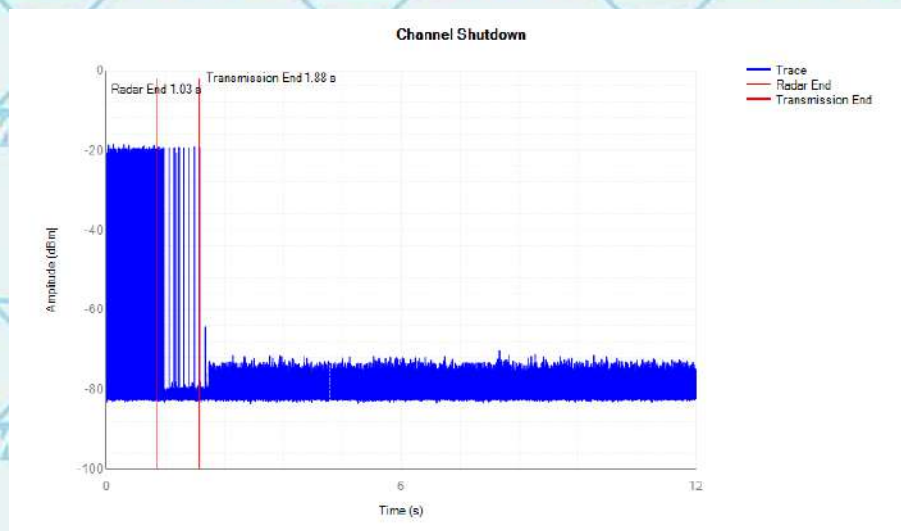
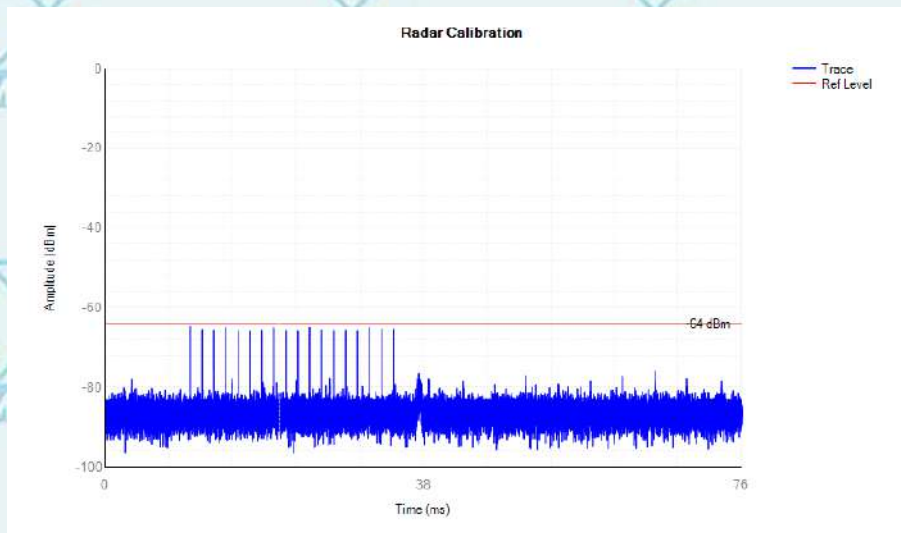



Report No.: WSCT-A2LA-R&E230300002A-Wi-Fi2

Certificate #5768.01

For Question,  
Please Contact with WSCT  
www.wsct-cert.com

**Measurement data below:**

5500MHz			
Test Items	Value (s)	Limit (s)	Test Result
Channel Closing Transmission Time	0.0088	1	Pass
Channel Move Time	0.9278	10	Pass

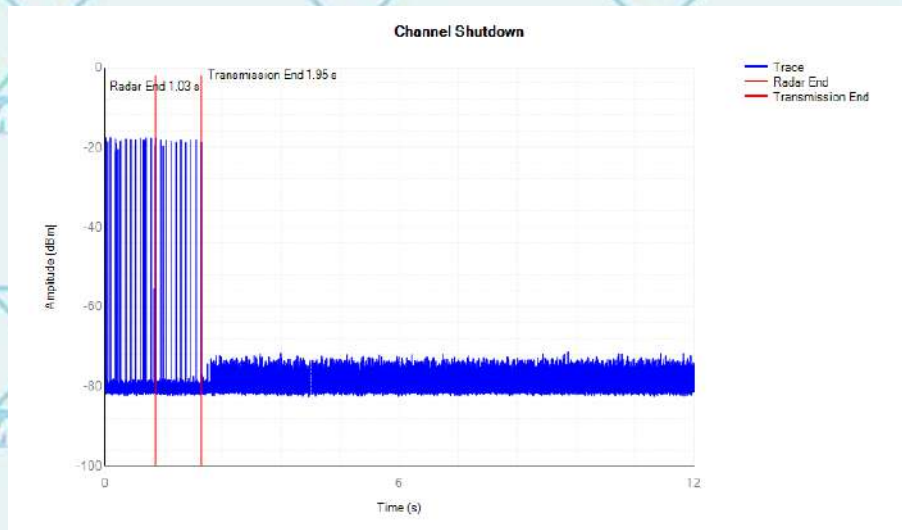
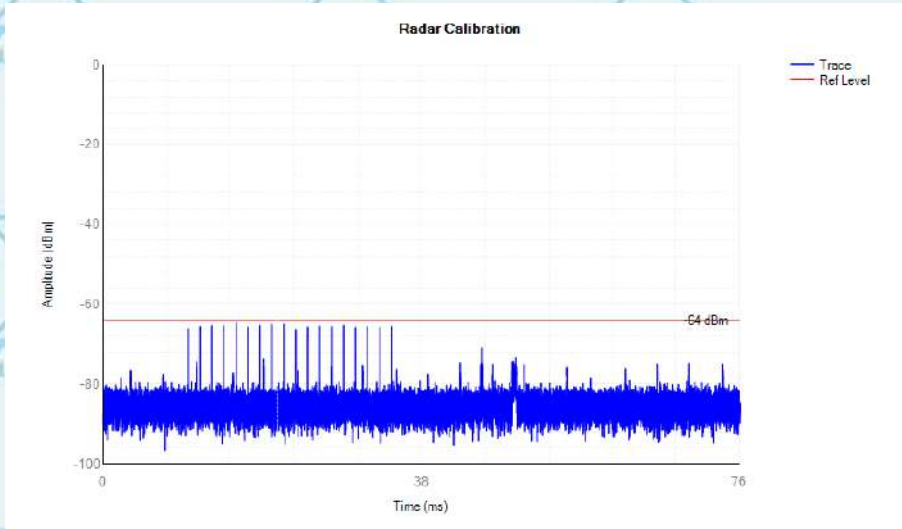

**\*\*\*\*\*END OF REPORT\*\*\*\*\***

