



FCC TEST REPORT

FCC ID: 2AMX5-SC230-V2

On Behalf of

Saregama Inc

CARVAAN

Model No.: SC230

Prepared for : Saregama Inc
Address : 200 Continental Drive, Suite 401, Newark, Delaware 19713, United States

Prepared By : Shenzhen Alpha Product Testing Co., Ltd.
Address : Building i, No.2, Lixin Road, Fuyong Street, Bao'an District, 518103, Shenzhen, Guangdong, China

Report Number : A2008280-C01-R02
Date of Receipt : June 21, 2022
Date of Test : June 21, 2022 – June 24, 2022
Date of Report : June 24, 2022
Version Number : V0

TABLE OF CONTENTS

Description	Page
1. Summary Of Standards And Results.....	6
1.1. Description of Standards and Results	6
2. General Information.....	7
2.1. Description of Device (EUT)	7
2.2. Accessories of Device (EUT)	8
2.3. Tested Supporting System Details	8
2.4. Block Diagram of connection between EUT and simulators	8
2.5. Test Mode Description	8
2.6. Test Conditions	8
2.7. Test Facility.....	9
2.8. Measurement Uncertainty	9
2.9. Test Equipment List	10
3. Maximum Peak Output Power	12
3.1. Limit	12
3.2. Test Procedure	12
3.3. Test Setup.....	12
3.4. Test Result.....	12
4. Bandwidth	13
4.1. Limit	13
4.2. Test Procedure	13
4.3. Test Result.....	13
5. Carrier Frequency Separation	23
5.1. Limit	23
5.2. Test Procedure	23
5.3. Test Result.....	23
6. Number Of Hopping Channel	25
6.1. Limit	25
6.2. Test Procedure	25
6.3. Test Result.....	25
7. Dwell Time	27
7.1. Test limit.....	27
7.2. Test Procedure	27
7.3. Test Result.....	27
8. Radiated Emissions.....	37
8.1. Limit	37
8.2. Block Diagram of Test setup.....	38
8.3. Test Procedure	39
8.4. Test Result.....	39
9. Band Edge Compliance	42

9.1. Block Diagram of Test Setup	42
9.2. Limit	42
9.3. Test Procedure	42
9.4. Test Result.....	42
10. Power Line Conducted Emissions.....	61
10.1. Block Diagram of Test Setup	61
10.2. Limit	61
10.3. Test Procedure	61
10.4. Test Result.....	61
11. Antenna Requirements	63
11.1. Limit	63
11.2. Result	63
12. Test Setup Photo	64
12.1. Photos of Radiated emission.....	64
13. Photos Of EUT	66

TEST REPORT DECLARATION

Applicant : Saregama Inc
 Address : 200 Continental Drive, Suite 401, Newark, Delaware 19713, United States
 Manufacturer : Shenzhen Kenuo Digital Technology Co., Ltd
 Address : 4F, Building B, Jinhong Industrial Park, Jiuwei Community, Hangcheng Street, Baoan District, Shenzhen, China
 EUT Description : CARVAAN
 (A) Model No. : SC230
 (B) Trademark : N/A

Measurement Standard Used:

FCC Rules and Regulations Part 15 Subpart C Section 15.247
ANSI C63.10:2013

The device described above is tested by Shenzhen Alpha Product Testing Co., Ltd. to determine the maximum emission levels emanating from the device. The maximum emission levels are compared to the FCC Part 15 Subpart C limits both conducted and radiated emissions. The test results are contained in this test report and Shenzhen Alpha Product Testing Co., Ltd. is assumed of full responsibility for the accuracy and completeness of these tests.

After the test, our opinion is that EUT compliance with the requirement of the above standards.

This report applies to above tested sample only. This report shall not be reproduced in parts without written approval of Shenzhen Alpha Product Testing Co., Ltd.

Tested by (name + signature).....: Yanniss Wen
 Project Engineer

Yanniss Wen

Approved by (name + signature).....: Simple Guan
 Project Manager

Simple Guan

Date of issue.....: June 24, 2022

Revision History

Revision	Issue Date	Revisions	Revised By
V0	June 24, 2022	Initial released Issue	Yannis Wen

1. Summary Of Standards And Results

1.1. Description of Standards and Results

The EUT have been tested according to the applicable standards as referenced below:

Test Item	Standards Paragraph	Result
Maximum Peak Output Power	FCC Part 15: 15.247(b)(1) ANSI C63.10 :2013	P
Bandwidth	FCC Part 15: 15.215 ANSI C63.10 :2013	P
Carrier Frequency Separation	FCC Part 15: 15.247(a)(1) ANSI C63.10 :2013	P
Number Of Hopping Channel	FCC Part 15: 15.247(a)(1)(iii) ANSI C63.10 :2013	P
Dwell Time	FCC Part 15: 15.247(a)(1)(iii) ANSI C63.10 :2013	P
Radiated Emission	FCC Part 15: 15.209 FCC Part 15: 15.247(d) ANSI C63.10 :2013	P
Band Edge Compliance	FCC Part 15: 15.247(d) ANSI C63.10 :2013	P
Power Line Conducted Emissions	FCC Part 15: 15.207 ANSI C63.10 :2013	P
Antenna requirement	FCC Part 15: 15.203	P
Note:	1. P is an abbreviation for Pass. 2. F is an abbreviation for Fail. 3. N/A is an abbreviation for Not Applicable.	

2. General Information

2.1. Description of Device (EUT)

Description	: CARVAAN
Trademark	: N/A
Model Number	: SC230
DIFF.	: N/A
Test Voltage	: DC 3.7V From Battery, DC 5V From Adapter
Radio Technology	: Bluetooth
Operation frequency	: 2402-2480MHz
Channel No.	: 79 Channels
Modulation type	: GFSK, $\pi/4$ DQPSK, 8DPSK
Antenna Type	: Internal antenna, Maximum Gain is 2dBi
Software version	: V1.0
Hardware version	: V1.0

2.2. Accessories of Device (EUT)

Accessories1	:	Adaptor
Manufacturer	:	Donguan jiyi Electric Co., Ltd
Model	:	JY6-050-100
INPUT	:	100-240V-50-60Hz 0.2A
OUTPUT	:	5V =1000mA

2.3. Tested Supporting System Details

No.	Description	Manufacturer	Model	Serial Number	Certification
1.	N/A	N/A	N/A	N/A	N/A

2.4. Block Diagram of connection between EUT and simulators

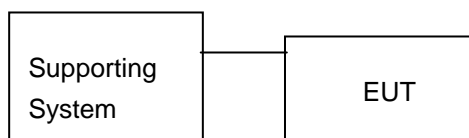

2.5. Test Mode Description

Tested mode, channel, and data rate information		
Mode	Channel	Frequency (MHz)
GFSK	Low :CH1	2402
	Middle: CH40	2441
	High: CH79	2480
$\pi/4$ DQPSK	Low :CH1	2402
	Middle: CH40	2441
	High: CH79	2480
8DPSK	Low :CH1	2402
	Middle: CH40	2441
	High: CH79	2480

2.6. Test Conditions

Items	Required	Actual
Temperature range:	15-35°C	24°C
Humidity range:	25-75%	56%
Pressure range:	86-106kPa	98kPa

2.7. Test Facility

Shenzhen Alpha Product Testing Co., Ltd
 Building i, No.2, Lixin Road, Fuyong Street, Bao'an District, 518103,
 Shenzhen, Guangdong, China

June 21, 2018 File on Federal Communication Commission
 Registration Number: 293961

July 15, 2019 Certificated by IC
 Registration Number: CN0085

2.8. Measurement Uncertainty

(95% confidence levels, k=2)

Item	Uncertainty
Uncertainty for Power point Conducted Emissions Test	1.63dB
Uncertainty for Radiation Emission test in 3m chamber (below 30MHz)	3.5dB
Uncertainty for Radiation Emission test in 3m chamber (30MHz to 1GHz)	3.74dB(Polarize: V)
	3.76dB(Polarize: H)
Uncertainty for Radiation Emission test in 3m chamber (1GHz to 25GHz)	3.77dB(Polarize: V)
	3.80dB(Polarize: H)
Uncertainty for radio frequency	5.06×10^{-8} GHz
Uncertainty for conducted RF Power	0.40dB
Uncertainty for temperature	0.2°C
Uncertainty for humidity	1%
Uncertainty for DC and low frequency voltages	0.06%

2.9. Test Equipment List

Equipment	Manufacture	Model No.	Firmware version	Serial No.	Last cal.	Cal Interval
9*6*6 anechoic chamber	CHENYU	9*6*6	/	N/A	2020.09.02	3Year
Spectrum analyzer	ROHDE&SCHWARZ	FSV40-N	2.3	102137	2021.08.25	1Year
Spectrum analyzer	Agilent	N9020A	A.14.16	MY499100060	2021.08.25	1Year
Receiver	ROHDE&SCHWARZ	ESR	2.28 SP1	1316.3003K03-10 2082-Wa	2021.08.25	1Year
Receiver	R&S	ESCI	4.42 SP1	101165	2021.08.25	1Year
Bilog Antenna	Schwarzbeck	VULB 9168	/	VULB 9168#627	2021.08.30	2Year
Horn Antenna	SCHWARZBECK	BBHA 9120 D	/	2106	2021.08.30	2Year
Active Loop Antenna	SCHWARZBECK	FMZB 1519B	/	00059	2021.08.30	2Year
RF Cable	Resenberger	Cable 1	/	RE1	2021.08.25	1Year
RF Cable	Resenberger	Cable 2	/	RE2	2021.08.25	1Year
RF Cable	Resenberger	Cable 3	/	CE1	2021.08.25	1Year
Pre-amplifier	HP	HP8347A	/	2834A00455	2021.08.25	1Year
Pre-amplifier	Agilent	8449B	/	3008A02664	2021.08.25	1Year
L.I.S.N.#1	Schwarzbeck	NSLK8126	/	8126-466	2021.08.25	1Year
L.I.S.N.#2	ROHDE&SCHWARZ	ENV216	/	101043	2021.08.25	1 Year
Horn Antenna	SCHWARZBECK	BBHA9170	/	00946	2021.08.30	2 Year
Preamplifier	SKET	LNPA_1840 -50	/	SK2018101801	2021.08.25	1 Year
Power Meter	Agilent	E9300A	/	MY41496628	2021.08.25	1 Year
Power Sensor	DARE	RPR3006W	/	15100041SNO91	2021.08.25	1 Year
Temp. & Humid. Chamber	Weihuang	WHTH-1000 -40-880	/	100631	2022.04.22	1 Year
Switching Mode Power Supply	JUNKE	JK12010S	/	20140927-6	2021.08.25	1 Year
Adjustable attenuator	MWRFTest	N/A	/	N/A	N/A	N/A
10dB Attenuator	Mini-Circuits	DC-6G	/	N/A	N/A	N/A

Software Information			
Test Item	Software Name	Manufacturer	Version
RE	EZ-EMC	farad	Alpha-3A1
CE	EZ-EMC	farad	Alpha-3A1

3. Maximum Peak Output Power

3.1. Limit

Please refer section 15.247.

For frequency hopping systems operating in the 2400-2483.5 MHz band employing at least 75 non-overlapping hopping channels, and all frequency hopping systems in the 5725-5850 MHz band: 1 watt. For all other frequency hopping systems in the 2400-2483.5 MHz band: 0.125 watts, the e.i.r.p shall not exceed 4W

3.2. Test Procedure

The transmitter output is connected to the RF Power Meter. The RF Power Meter is set to the average power detection.

3.3. Test Setup

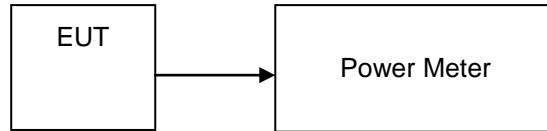

3.4. Test Result

Mode	Freq (MHz)	Average Output Power (dBm)	Limit (dBm)	Result
GFSK	2402	-3.011	21	Pass
	2441	-4.345	21	Pass
	2480	-5.043	21	Pass
$\pi/4$ DQPSK	2402	-1.053	21	Pass
	2441	-2.652	21	Pass
	2480	-3.528	21	Pass
8DPSK	2402	-2.206	21	Pass
	2441	-2.505	21	Pass
	2480	-3.114	21	Pass

Conclusion: PASS

4. Bandwidth

4.1. Limit

Intentional radiators operating under the alternative provisions to the general emission limits, as contained in §§ 15.217 through 15.257 and in Subpart E of this part, must be designed to ensure that the 20 dB bandwidth of the emission, or whatever bandwidth may otherwise be specified in the specific rule section under which the equipment operates, is contained within the frequency band designated in the rule section under which the equipment is operated.

4.2. Test Procedure

The RF output of EUT was connected to the spectrum analyzer by RF cable and attenuator. The bandwidth of the fundamental frequency was measured by spectrum analyzer with 30kHz RBW and 100kHz VBW. The 20dB bandwidth is defined as the total spectrum the power of which is higher than peak power minus 20dB.

4.3. Test Result

Condition	Mode	Frequency (MHz)	Antenna	99% OBW (MHz)	-20 dB Bandwidth (MHz)	Limit -20 dB Bandwidth (MHz)	Verdict
NVNT	1-DH1	2402	Ant 1	0.775	0.886	0	Pass
NVNT	1-DH1	2441	Ant 1	0.777	0.848	0	Pass
NVNT	1-DH1	2480	Ant 1	0.787	0.838	0	Pass
NVNT	2-DH1	2402	Ant 1	1.173	1.244	0	Pass
NVNT	2-DH1	2441	Ant 1	1.165	1.264	0	Pass
NVNT	2-DH1	2480	Ant 1	1.173	1.234	0	Pass
NVNT	3-DH1	2402	Ant1	1.143	1.206	0	Pass
NVNT	3-DH1	2441	Ant1	1.151	1.206	0	Pass
NVNT	3-DH1	2480	Ant1	1.149	1.206	0	Pass

OBW NVNT 1-DH1 2402MHz Ant1

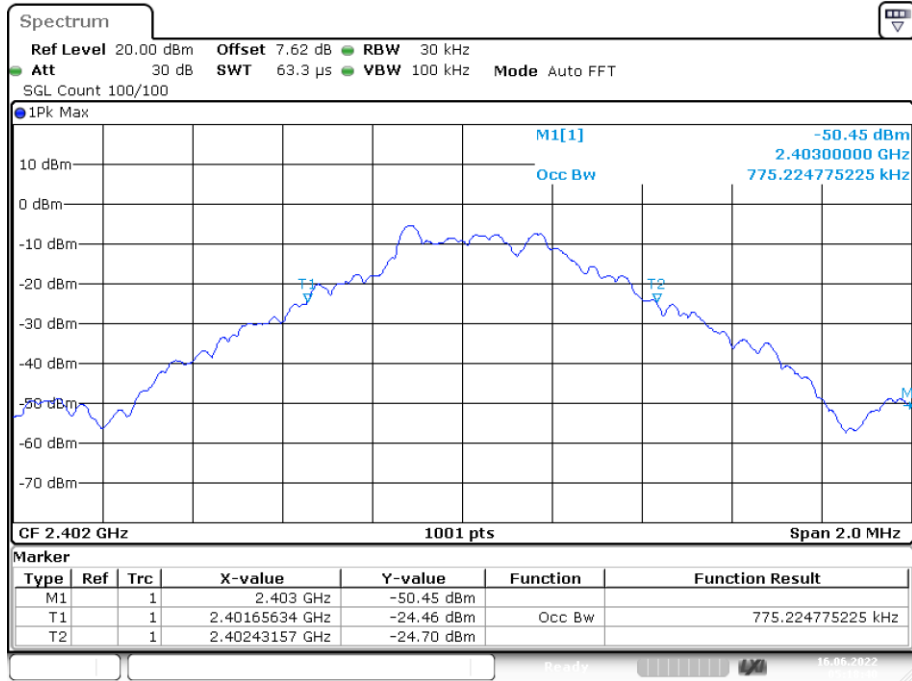

-20 dB BW NVNT 1-DH1 2402MHz Ant1

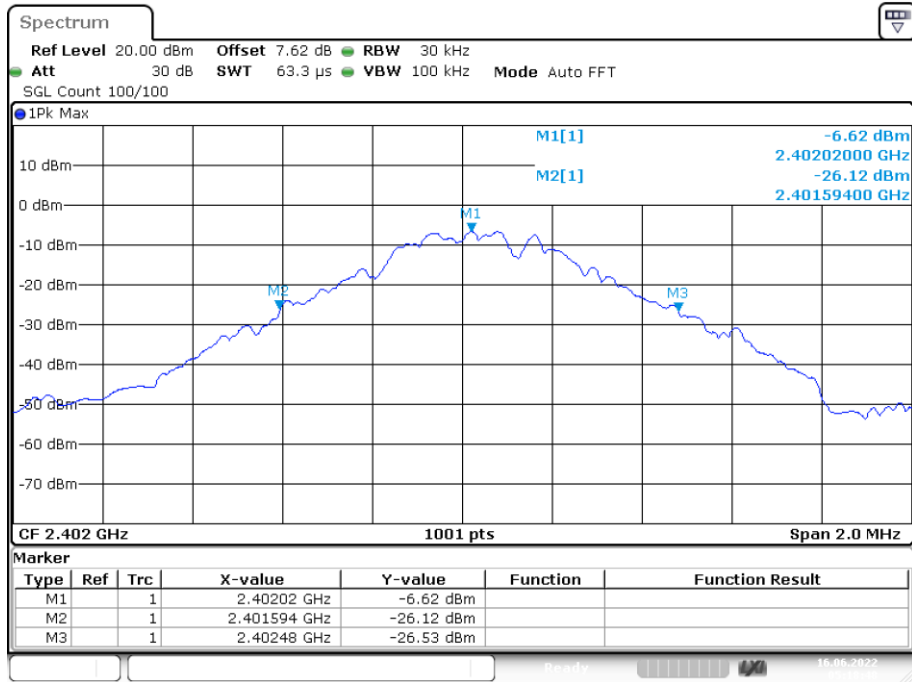

OBW NVNT 1-DH1 2441MHz Ant1

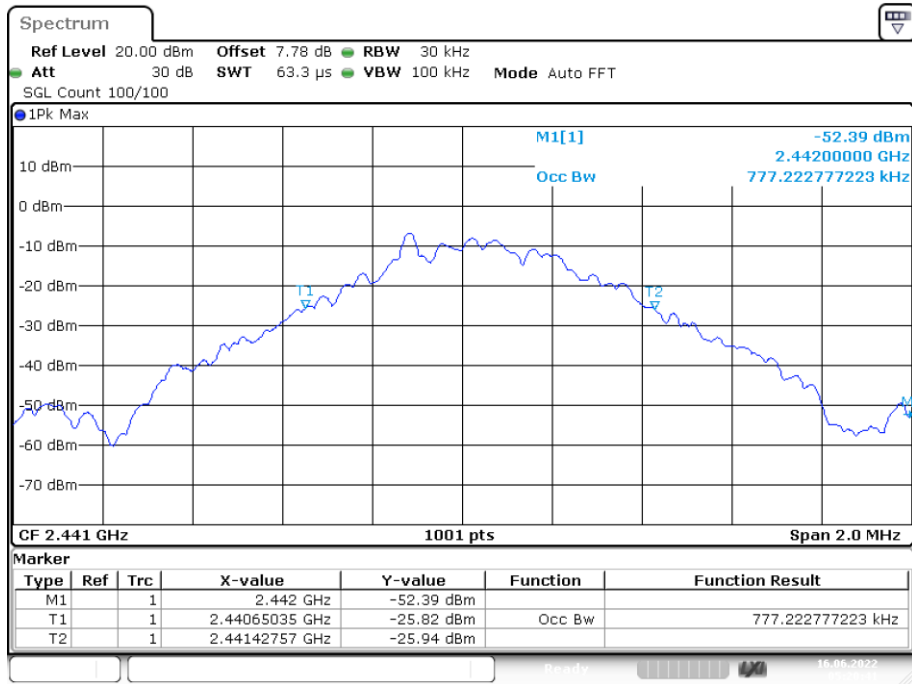

Date: 16.JUN.2022 05:20:40

-20 dB BW NVNT 1-DH1 2441MHz Ant1

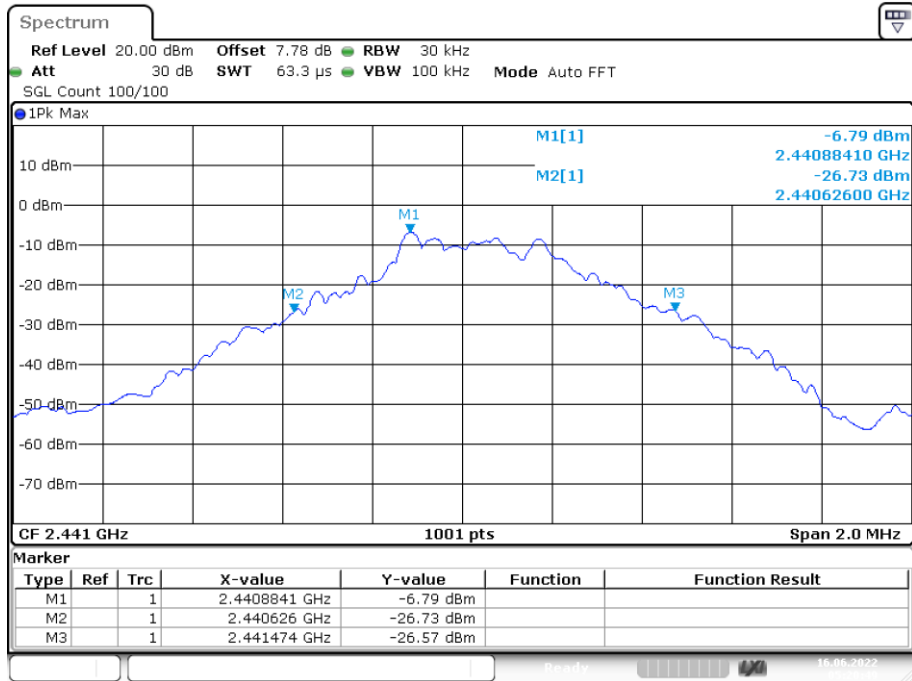

Date: 16.JUN.2022 05:20:48

OBW NVNT 1-DH1 2480MHz Ant1

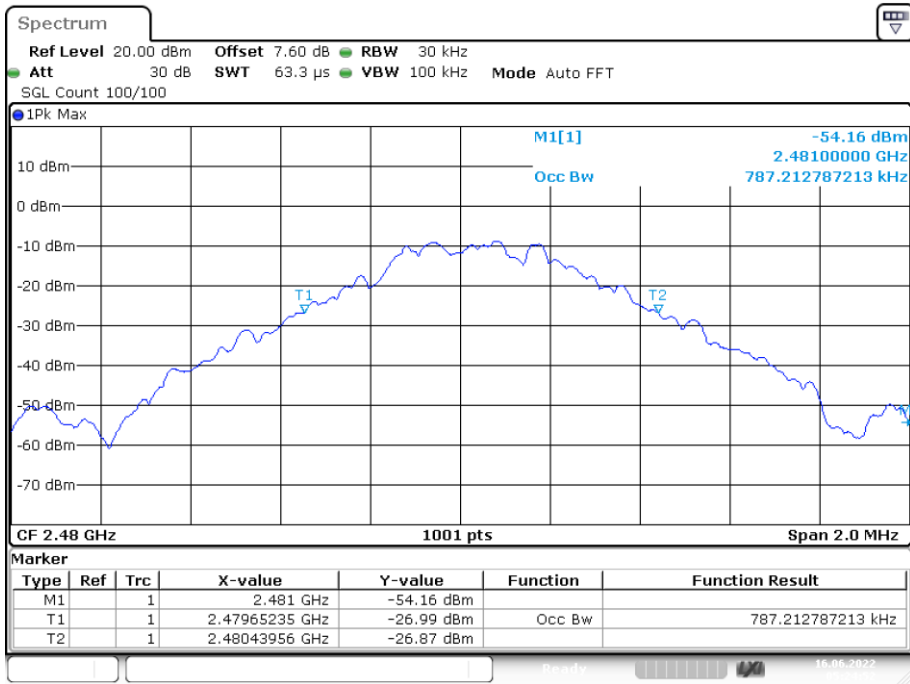

Date: 16.JUN.2022 05:24:52

-20 dB BW NVNT 1-DH1 2480MHz Ant1

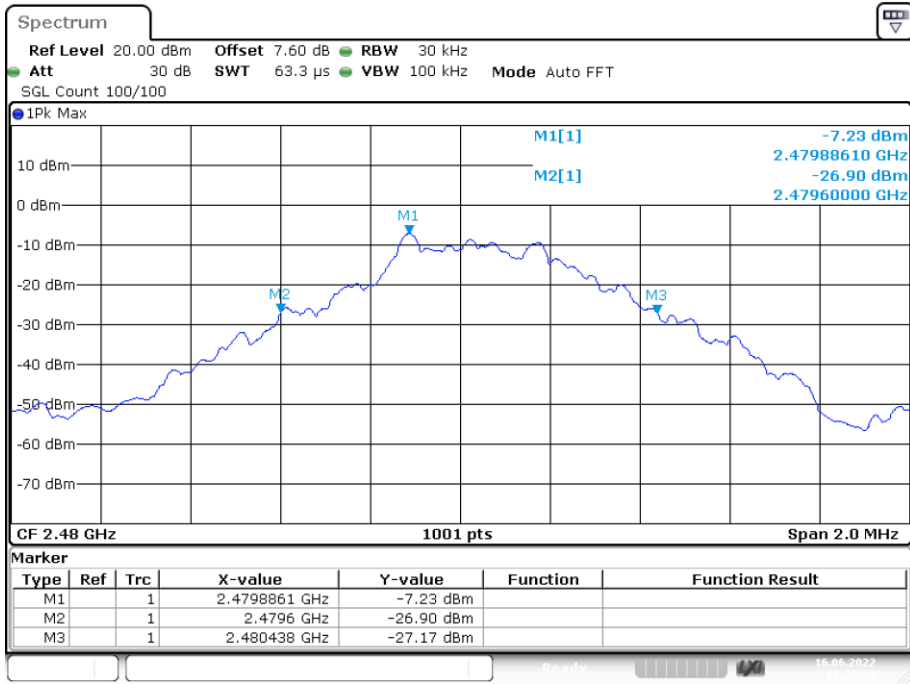

Date: 16.JUN.2022 05:25:00

OBW NVNT 2-DH1 2402MHz Ant1

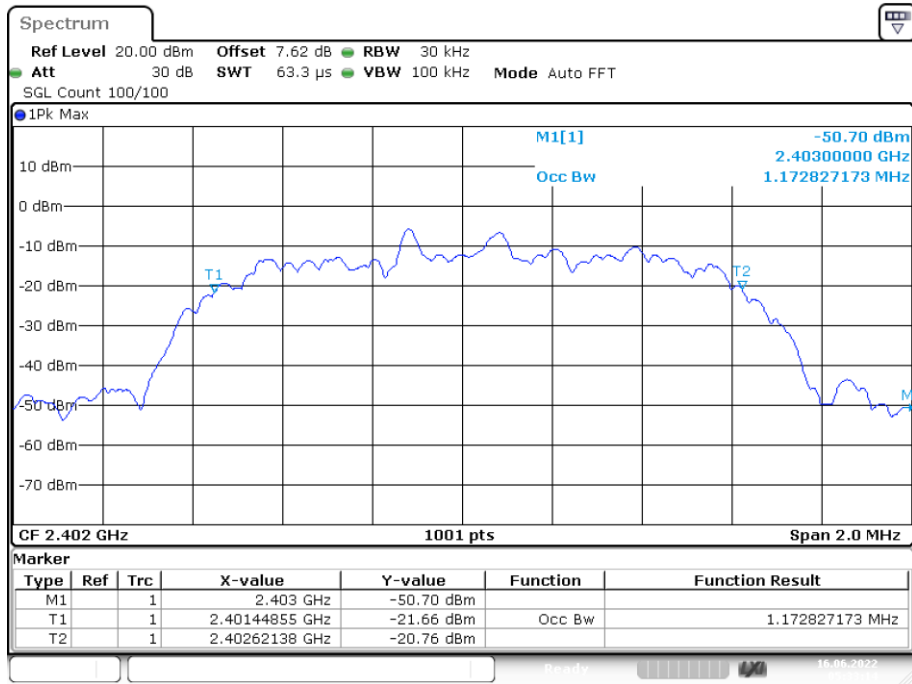

Date: 16.JUN.2022 05:33:14

-20 dB BW NVNT 2-DH1 2402MHz Ant1

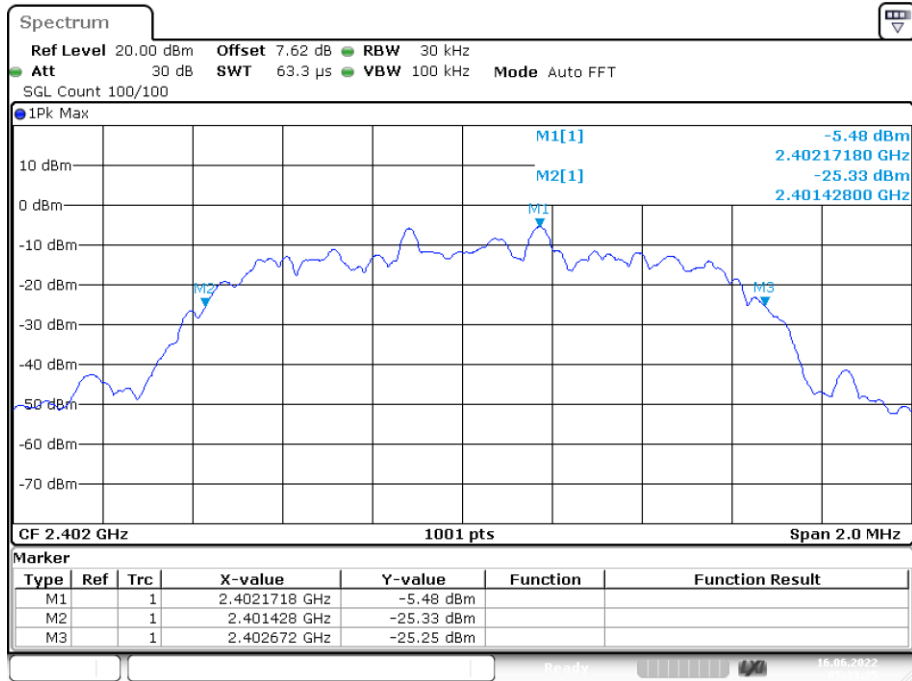

Date: 16.JUN.2022 05:33:25

OBW NVNT 2-DH1 2441MHz Ant1

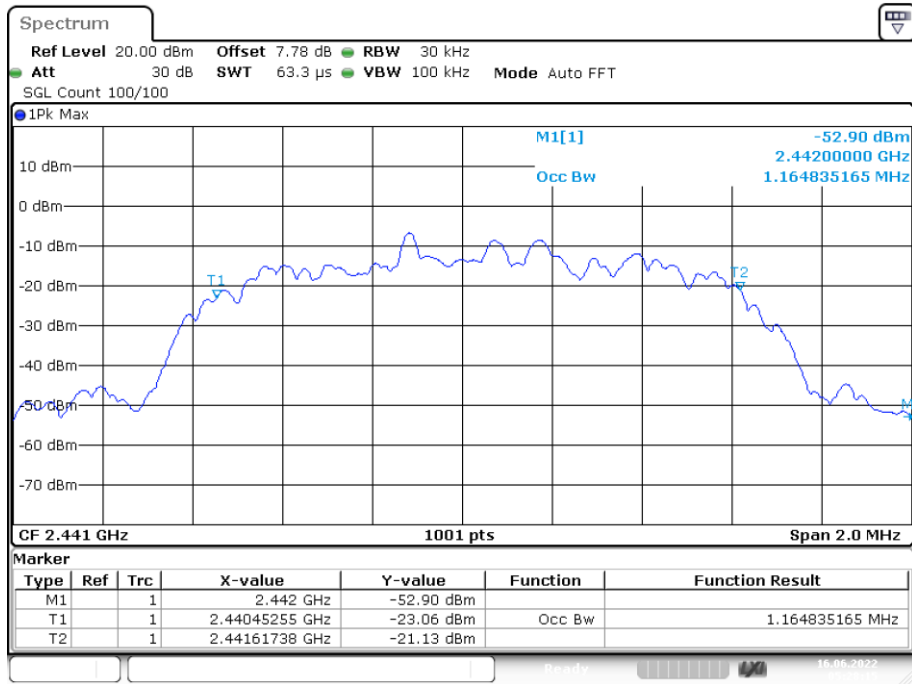

Date: 16.JUN.2022 05:28:15

-20 dB BW NVNT 2-DH1 2441MHz Ant1

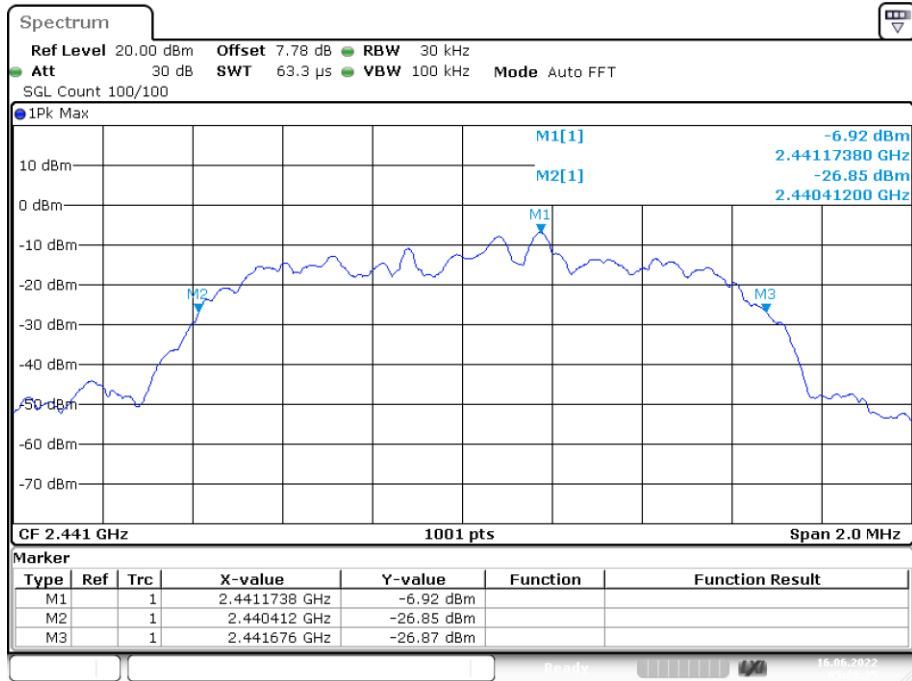

Date: 16.JUN.2022 05:28:24

OBW NVNT 2-DH1 2480MHz Ant1

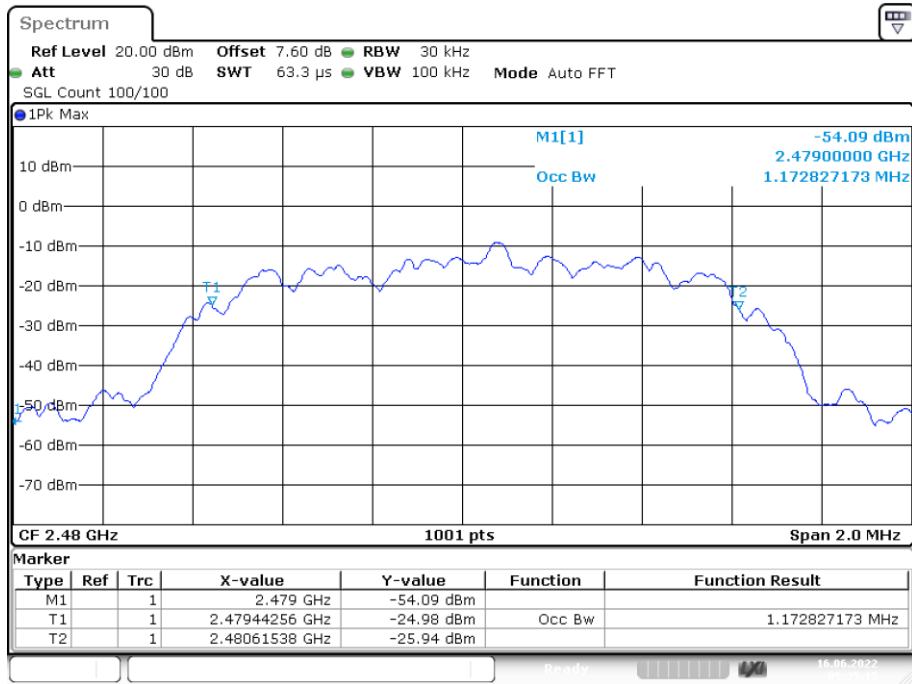

Date: 16.JUN.2022 05:35:15

-20 dB BW NVNT 2-DH1 2480MHz Ant1

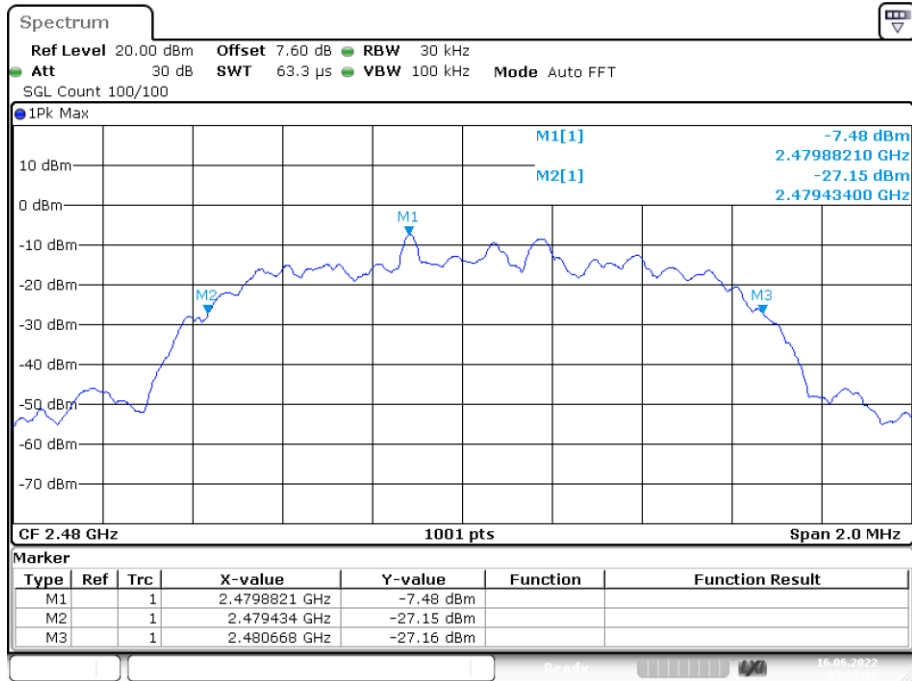

Date: 16.JUN.2022 05:35:26

OBW NVNT 3-DH1 2402MHz Ant1

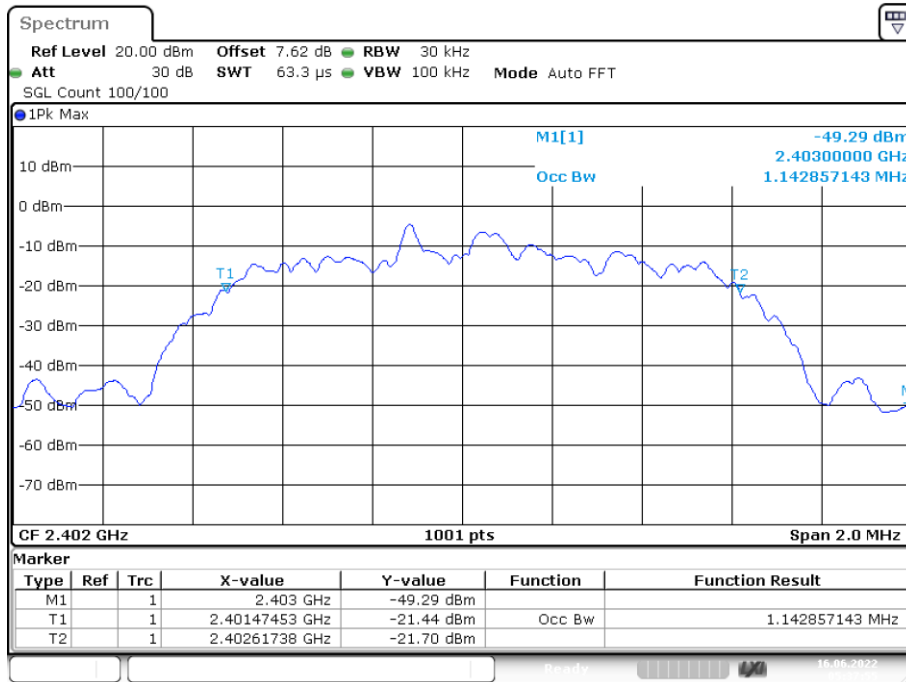

Date: 16.JUN.2022 05:37:55

-20 dB BW NVNT 3-DH1 2402MHz Ant1

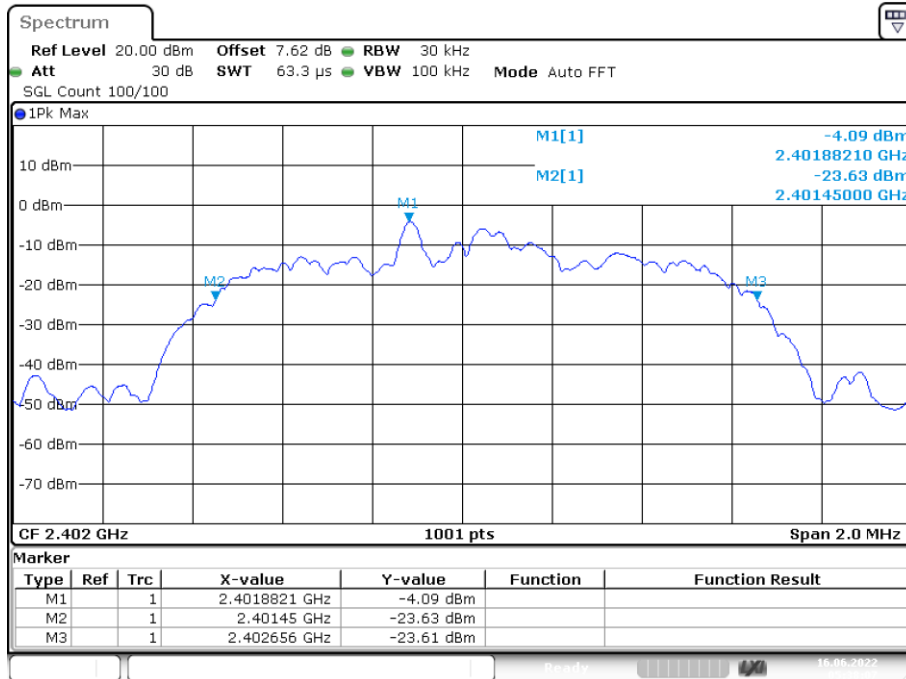

Date: 16.JUN.2022 05:38:07

OBW NVNT 3-DH1 2441MHz Ant1

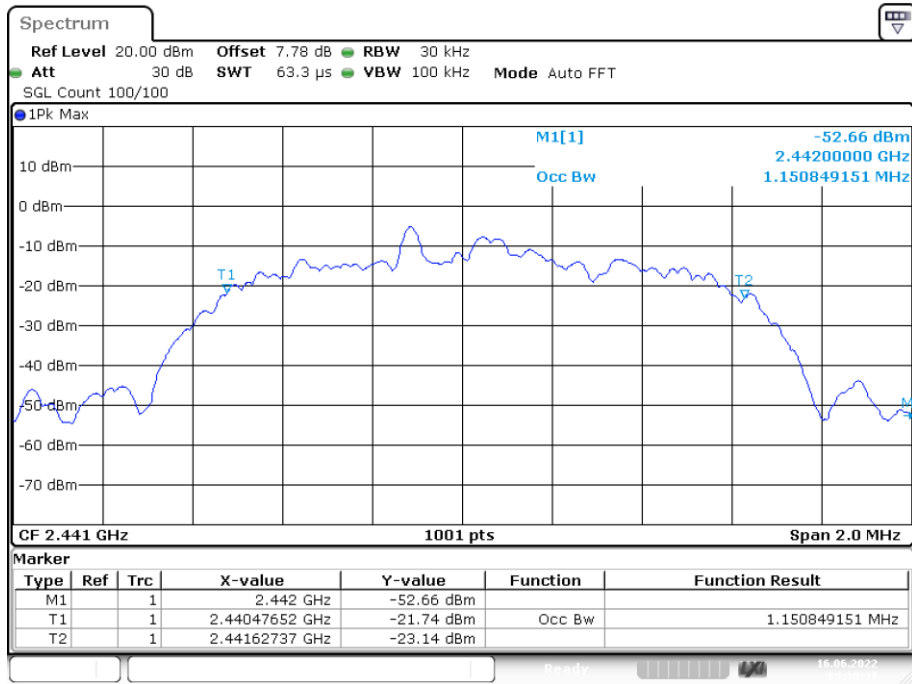

Date: 16.JUN.2022 05:30:37

-20 dB BW NVNT 3-DH1 2441MHz Ant1

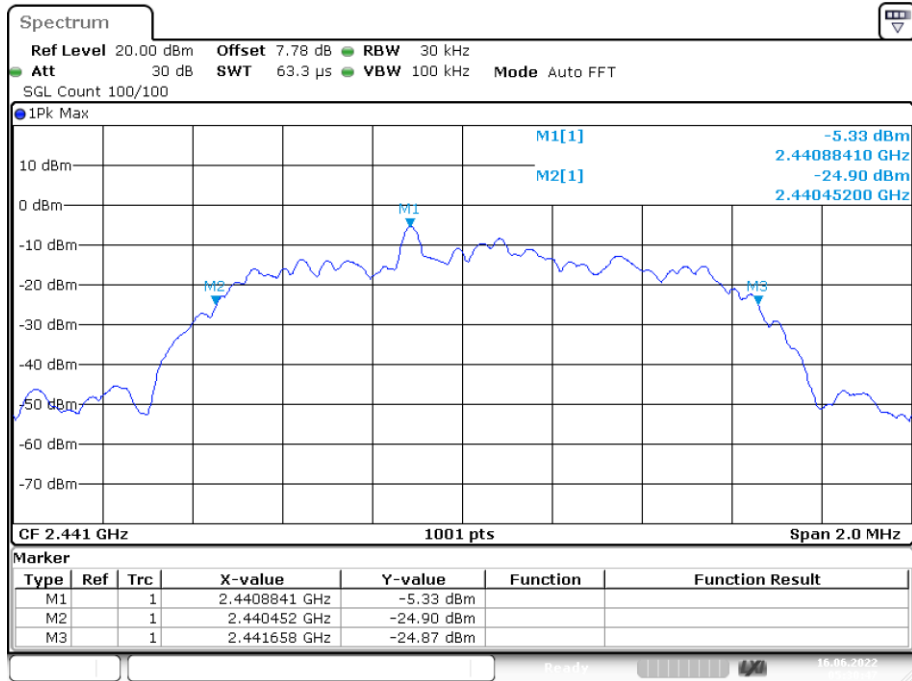

Date: 16.JUN.2022 05:30:47

OBW NVNT 3-DH1 2480MHz Ant1

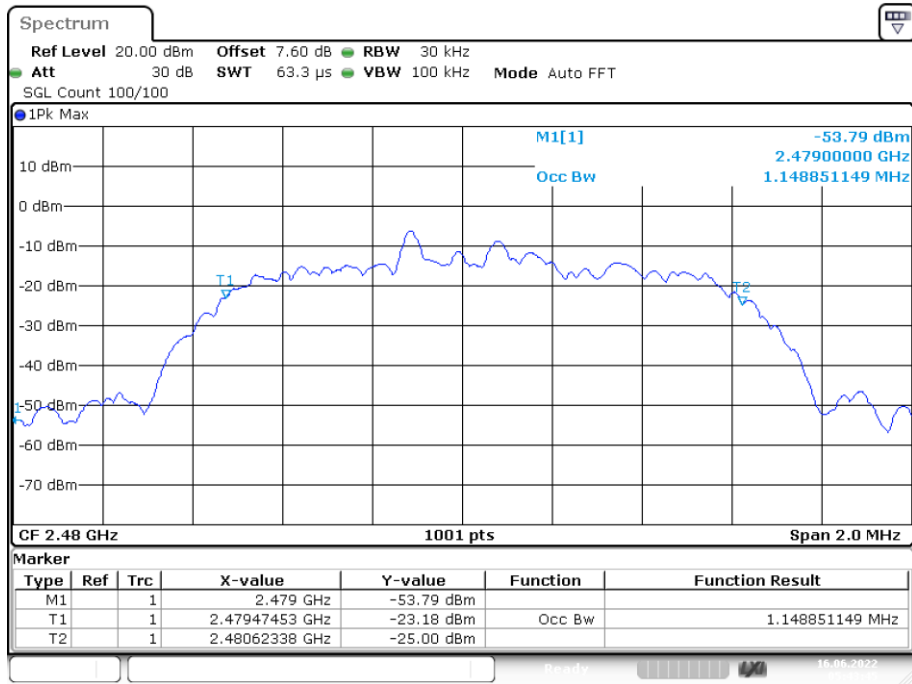

Date: 16.JUN.2022 05:43:44

-20 dB BW NVNT 3-DH1 2480MHz Ant1

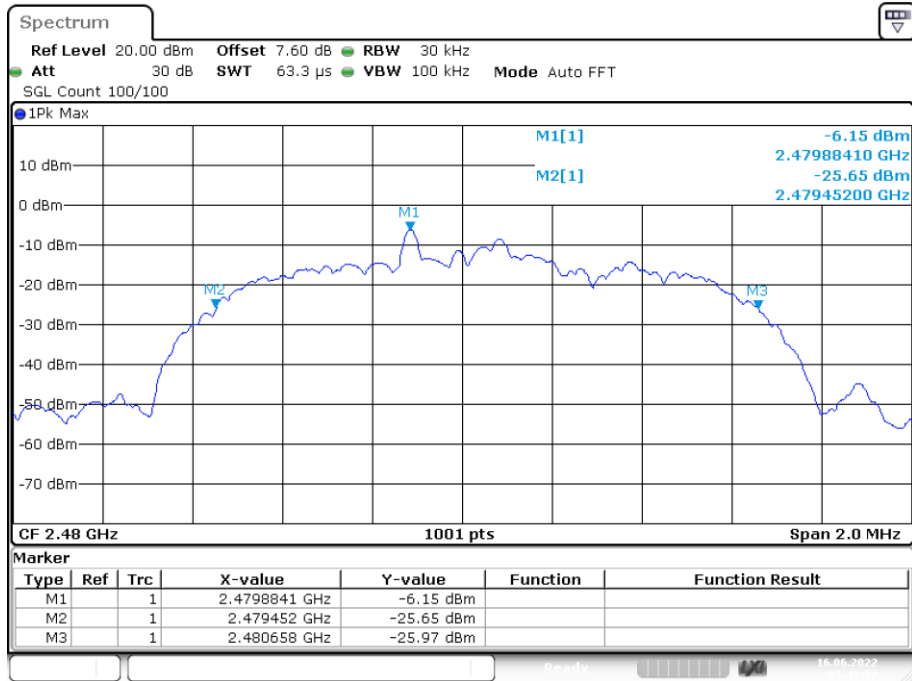

Date: 16.JUN.2022 05:43:56

5. Carrier Frequency Separation

5.1. Limit

Frequency hopping systems shall have hopping channel carrier frequencies separated by a minimum of 25 kHz or the 20 dB bandwidth of the hopping channel, whichever is greater. Alternatively, frequency hopping systems operating in the 2400-2483.5 MHz band may have hopping channel carrier frequencies that are separated by 25 kHz or two-thirds of the 20 dB bandwidth of the hopping channel, whichever is greater, provided the systems operate with an output power no greater than 125 mW

5.2. Test Procedure

The RF output of EUT was connected to the spectrum analyzer by RF cable and attenuator. The carrier frequency was measured by spectrum analyzer with 20kHz RBW and 62kHz VBW.

5.3. Test Result

Condition	Mode	Antenna	Hopping Freq1 (MHz)	Hopping Freq2 (MHz)	HFS (MHz)	Limit (MHz)	Verdict
NVNT	1-DH1	Ant1	2441.047	2442.047	1	0.848	Pass
NVNT	2-DH1	Ant1	2440.882	2441.882	1	0.843	Pass
NVNT	3-DH1	Ant1	2440.884	2441.884	1	0.804	Pass

CFS NVNT 1-DH1 2441MHz Ant1

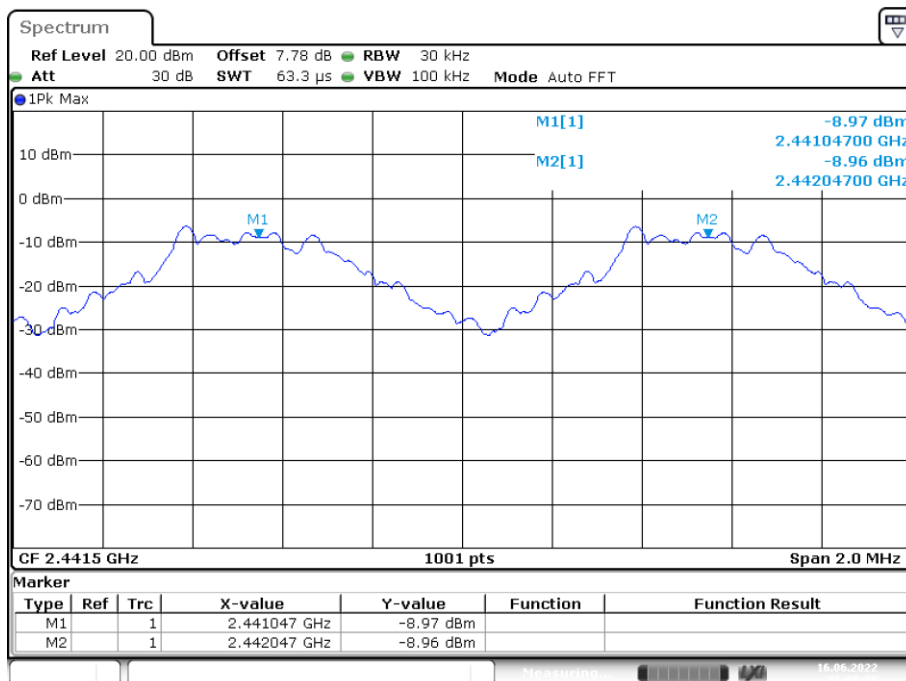

Date: 16.JUN.2022 06:00:59

CFS NVNT 2-DH1 2441MHz Ant1

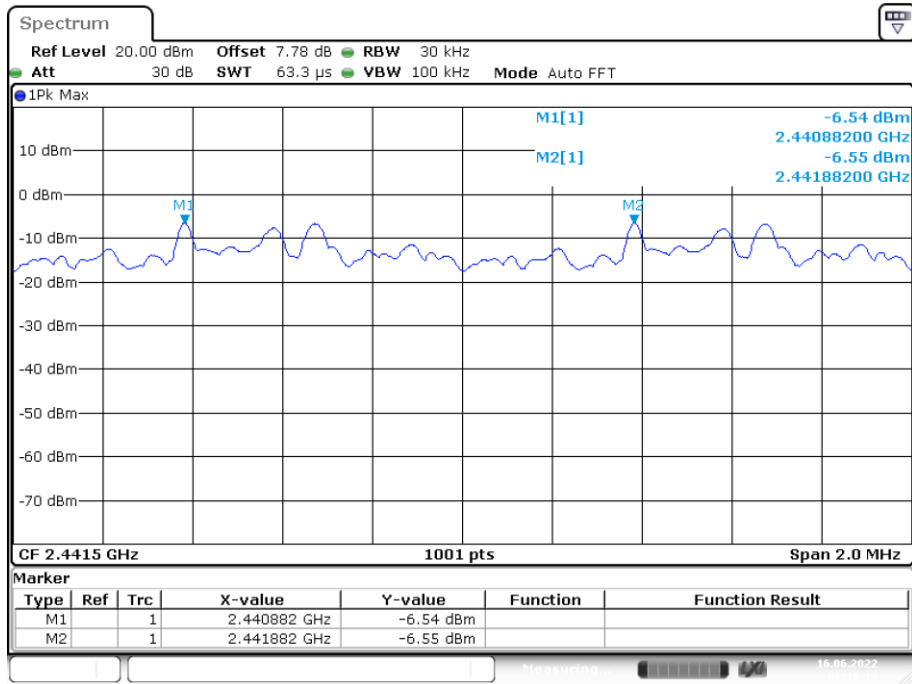

Date: 16.JUN.2022 06:16:14

CFS NVNT 3-DH1 2441MHz Ant1

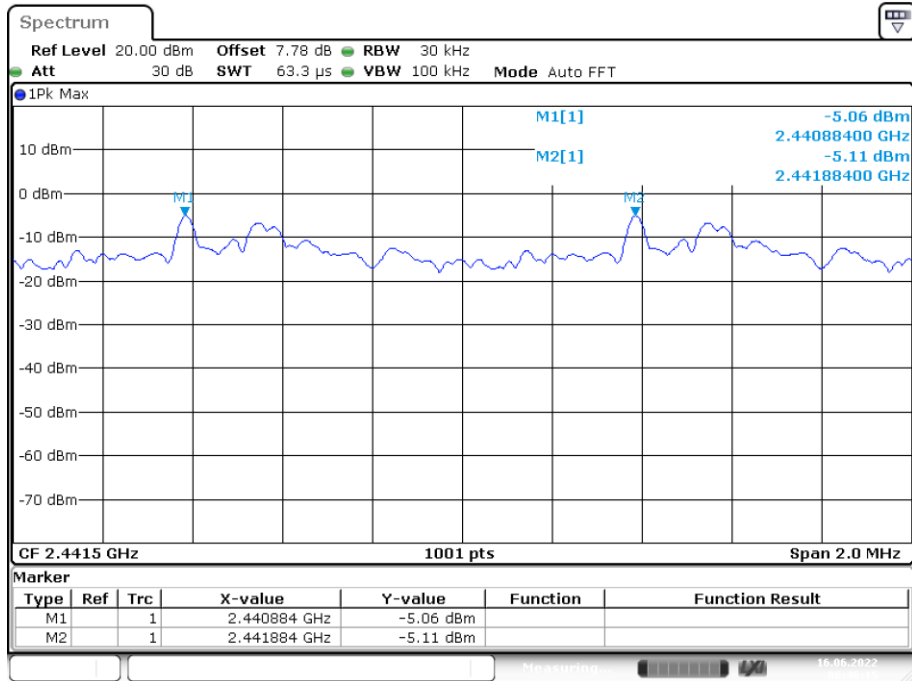

Date: 16.JUN.2022 06:46:15

6. Number Of Hopping Channel

6.1. Limit

Frequency hopping systems in the 2400-2483.5 MHz band shall use at least 15 channels

6.2. Test Procedure

The RF output of EUT was connected to the spectrum analyzer by RF cable and attenuator. The number of hopping channel was measured by spectrum analyzer with 100kHz RBW and 300KHz VBW.

6.3. Test Result

Condition	Mode	Hopping Number	Limit	Verdict
NVNT	1-DH1	79	15	Pass
NVNT	2-DH1	79	15	Pass
NVNT	3-DH1	79	15	Pass

Hopping No. NVNT 1-DH1 2441MHz Ant1

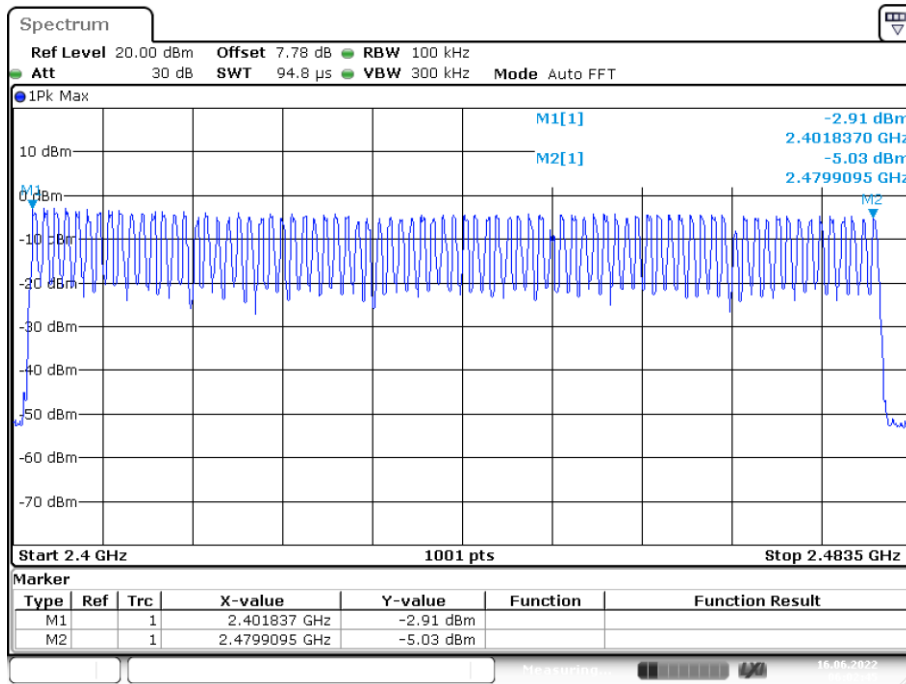

Date: 16.JUN.2022 06:02:45

Hopping No. NVNT 2-DH1 2441MHz Ant1

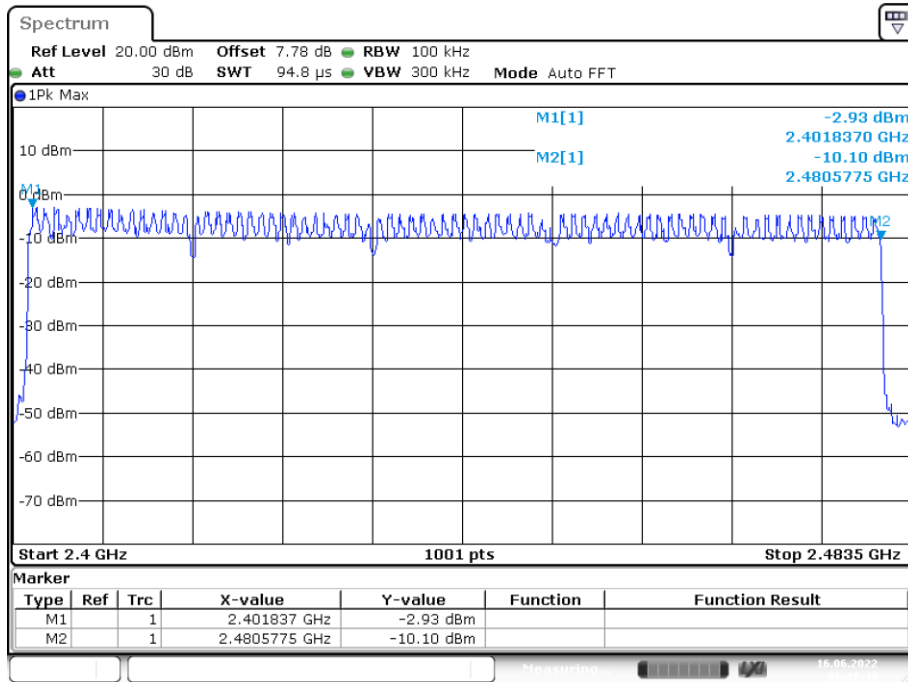

Date: 16.JUN.2022 06:19:49

Hopping No. NVNT 3-DH1 2441MHz Ant1

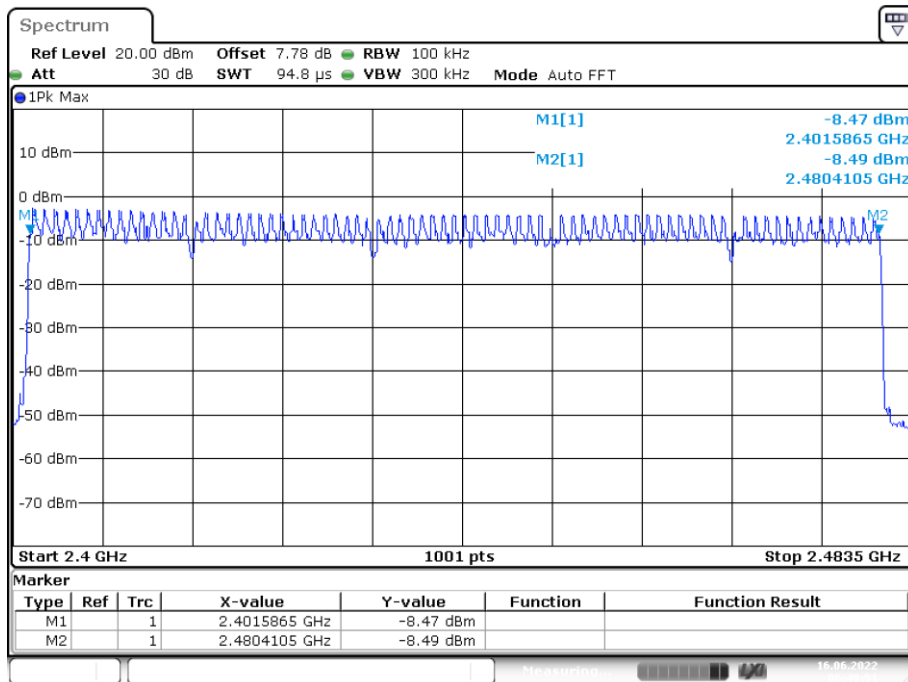

Date: 16.JUN.2022 06:49:51

7. Dwell Time

7.1. Test limit

Please refer section 15.247

According to §15.247(a)(1)(iii), Frequency hopping systems operating in the 2400MHz-2483.5 MHz. The average time of occupancy on any frequency shall not greater than 0.4 s within period of 0.4 sec- onds multiplied by the number of hopping channel employed.

7.2. Test Procedure

7.2.1. Place the EUT on the table and set it in transmitting mode.

7.2.2. Remove the antenna from the EUT and then connect a low loss RF cable from the antenna port to the spectrum analyzer.

7.2.3. Set center frequency of spectrum analyzer = operating frequency.

7.2.4. Set the spectrum analyzer as RBW=1MHz, VBW=1MHz, Span = 0Hz, Sweep = auto.

7.2.5. Repeat above procedures until all frequency measured were complete.

7.3. Test Result

PASS.

Condition	Mode	Frequency (MHz)	Pulse Time (ms)	Total Dwell Time (ms)	Period Time (ms)	Limit (ms)	Verdict
NVNT	1-DH1	2441	0.389	124.480	31600	400	Pass
NVNT	1-DH3	2441	1.642	262.720	31600	400	Pass
NVNT	1-DH5	2441	2.89	308.267	31600	400	Pass
NVNT	2-DH1	2441	0.395	126.400	31600	400	Pass
NVNT	2-DH3	2441	1.625	260.000	31600	400	Pass
NVNT	2-DH5	2441	2.897	309.013	31600	400	Pass
NVNT	3-DH1	2441	0.4	128.000	31600	400	Pass
NVNT	3-DH3	2441	1.644	263.040	31600	400	Pass
NVNT	3-DH5	2441	2.9	309.333	31600	400	Pass

Note: 1. A period time = 0.4 (s) * 79 = 31.6(s)

2. DH1 Dwell Time = Pulse Time * (1600/(2*79)) * A period time

DH3 Dwell Time = Pulse Time * (1600/(4*79)) * A period time

DH5 Dwell Time = Pulse Time * (1600/(6*79)) * A period time

Dwell NVNT 1-DH1 2441MHz Ant1 One Burst

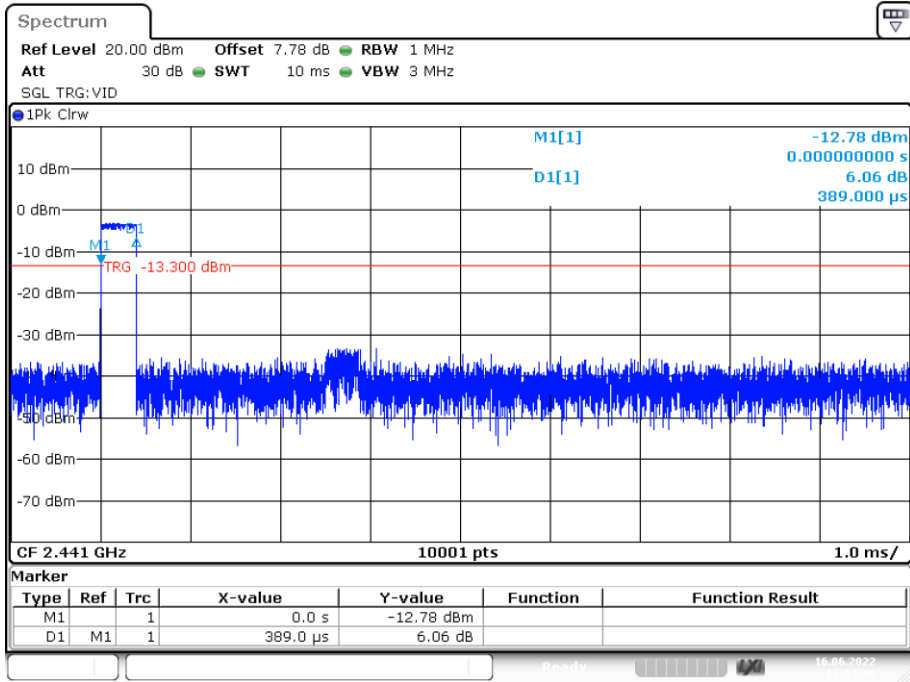

Date: 16.JUN.2022 06:03:00

Dwell NVNT 1-DH1 2441MHz Ant1 Accumulated

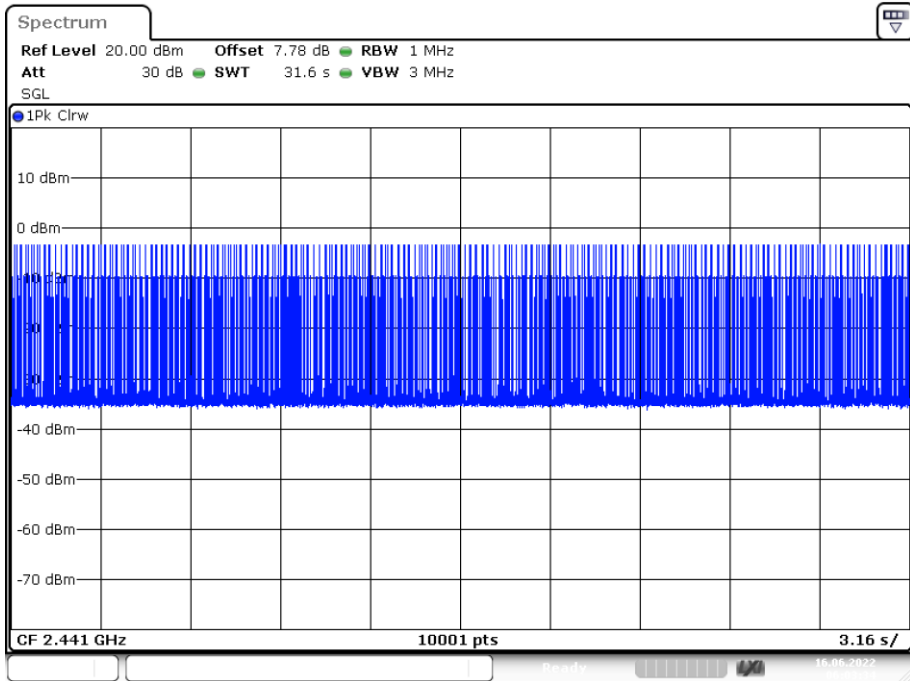

Date: 16.JUN.2022 06:03:34

Dwell NVNT 1-DH3 2441MHz Ant1 One Burst

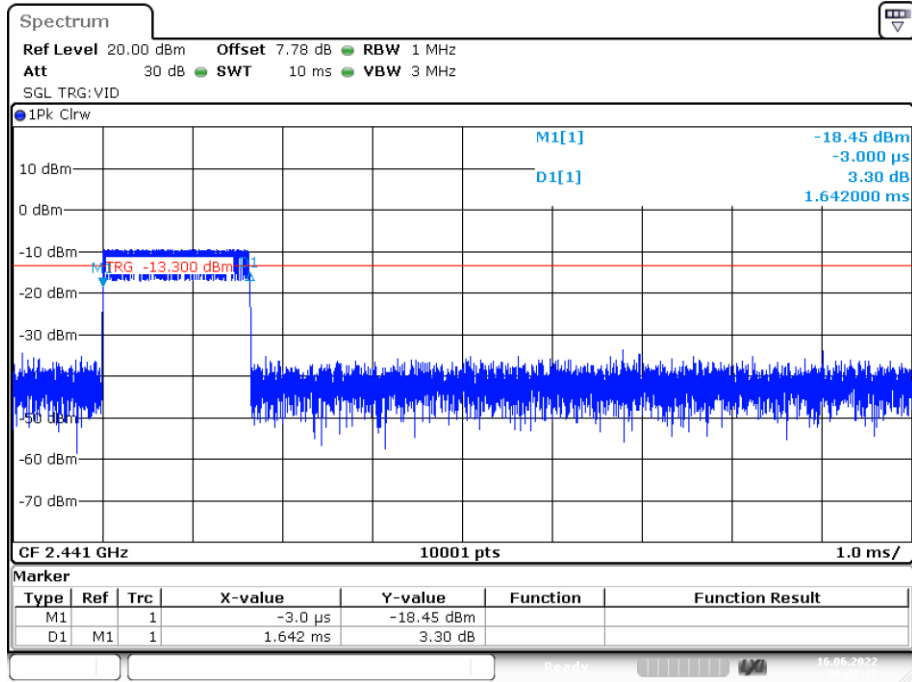

Date: 16.JUN.2022 06:07:17

Dwell NVNT 1-DH3 2441MHz Ant1 Accumulated

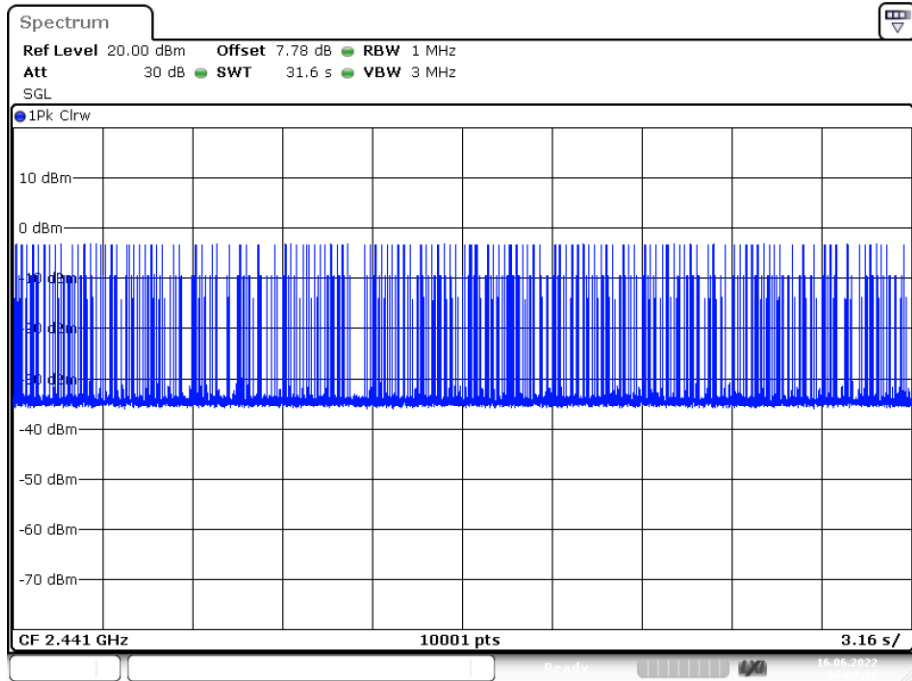

Date: 16.JUN.2022 06:07:51

Dwell NVNT 1-DH5 2441MHz Ant1 One Burst

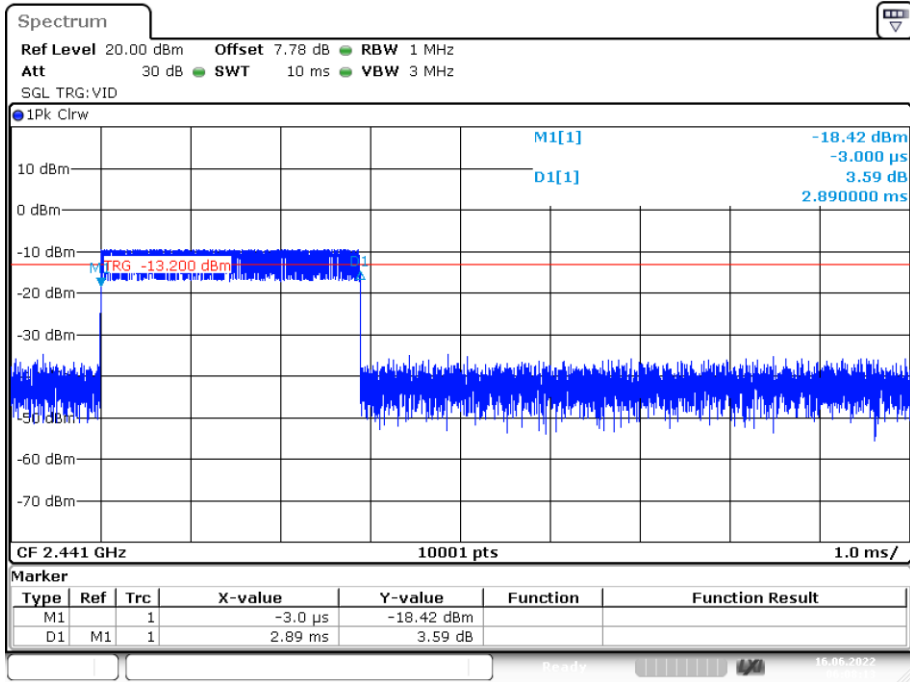

Date: 16.JUN.2022 06:08:12

Dwell NVNT 1-DH5 2441MHz Ant1 Accumulated

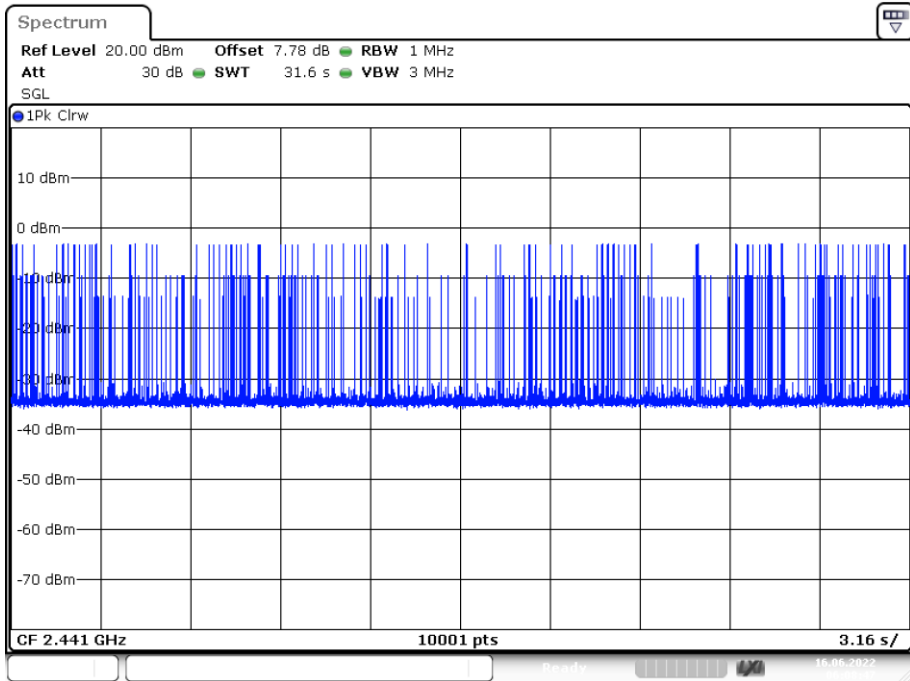

Date: 16.JUN.2022 06:08:47

Dwell NVNT 2-DH1 2441MHz Ant1 One Burst

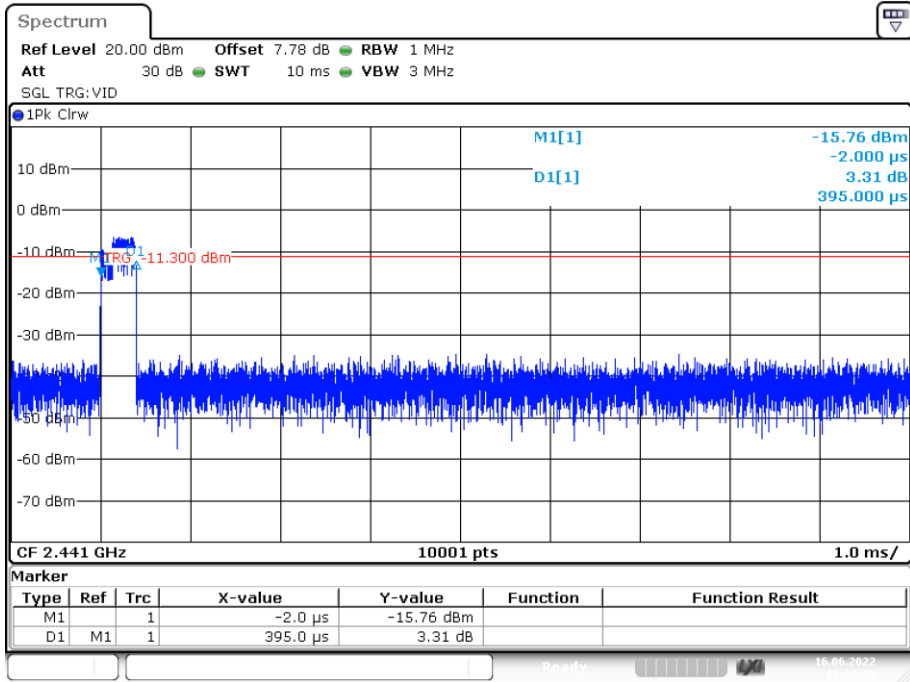

Date: 16.JUN.2022 06:20:05

Dwell NVNT 2-DH1 2441MHz Ant1 Accumulated

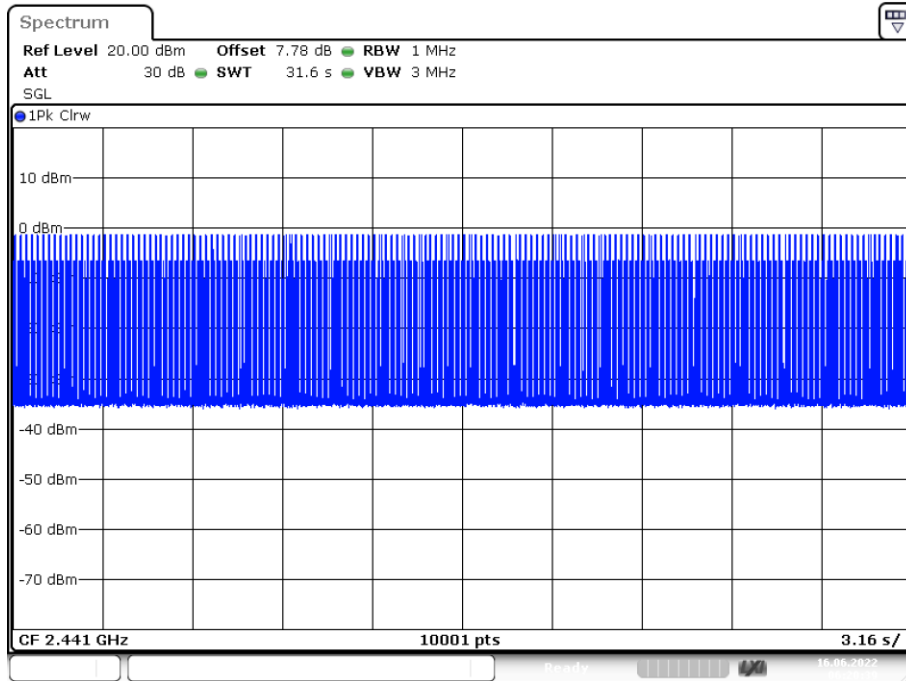

Date: 16.JUN.2022 06:20:39

Dwell NVNT 2-DH3 2441MHz Ant1 One Burst

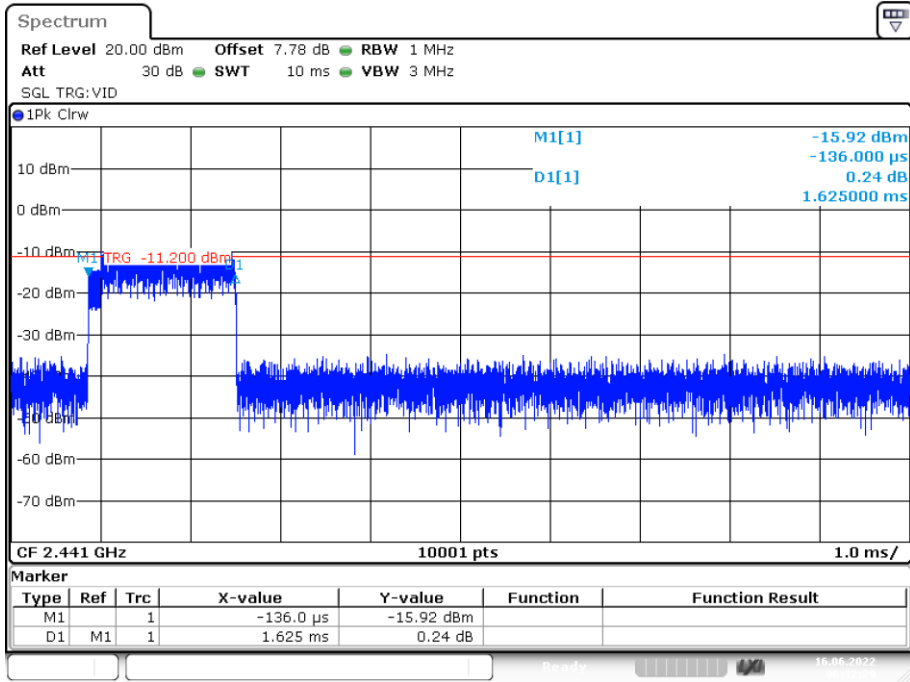

Date: 16.JUN.2022 06:32:29

Dwell NVNT 2-DH3 2441MHz Ant1 Accumulated

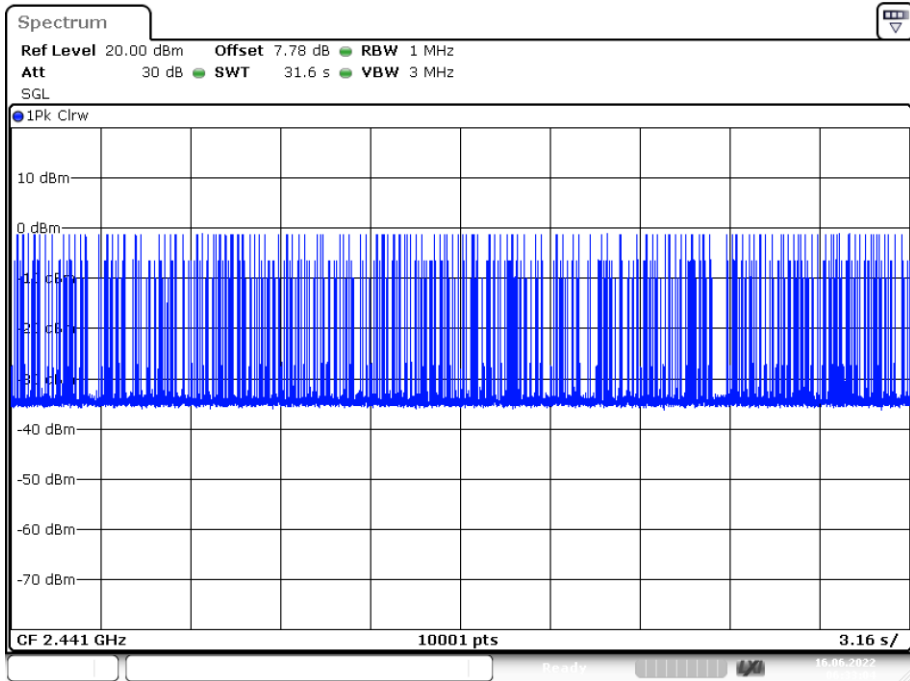

Date: 16.JUN.2022 06:33:04

Dwell NVNT 2-DH5 2441MHz Ant1 One Burst

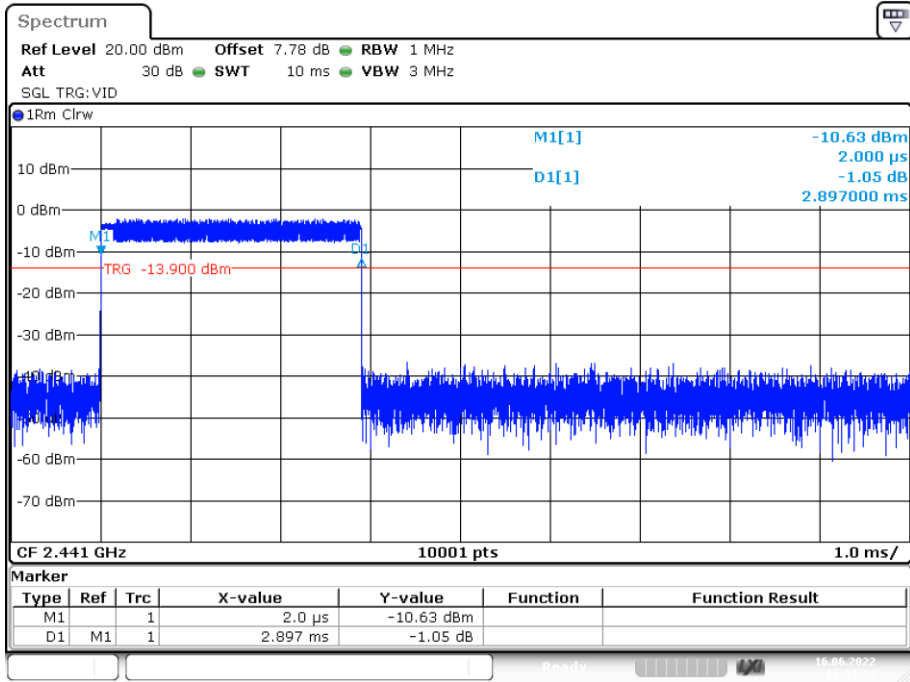

Date: 16.JUN.2022 06:33:24

Dwell NVNT 2-DH5 2441MHz Ant1 Accumulated

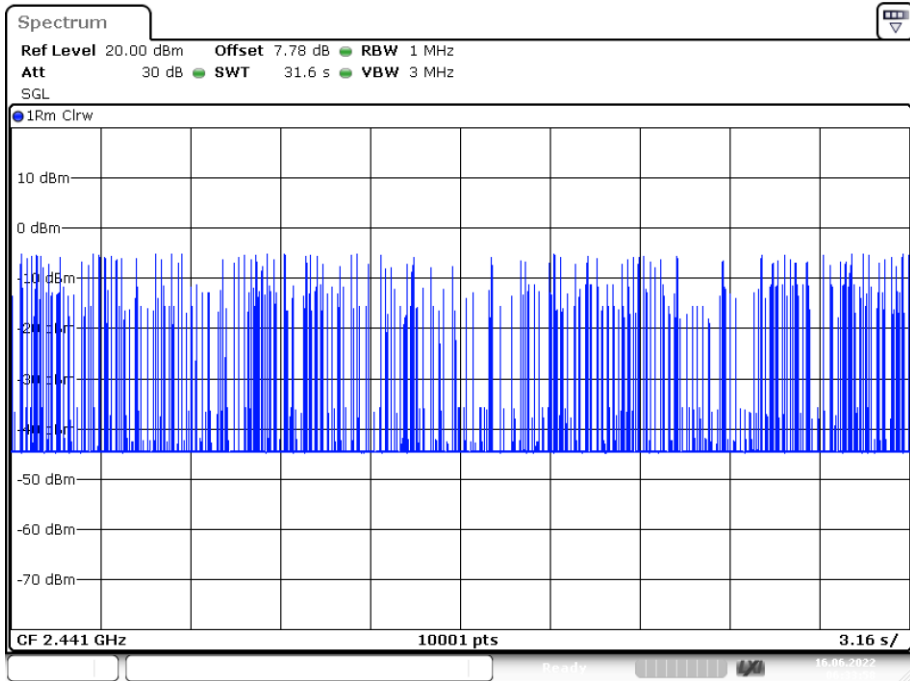

Date: 16.JUN.2022 06:33:59

Dwell NVNT 3-DH1 2441MHz Ant1 One Burst

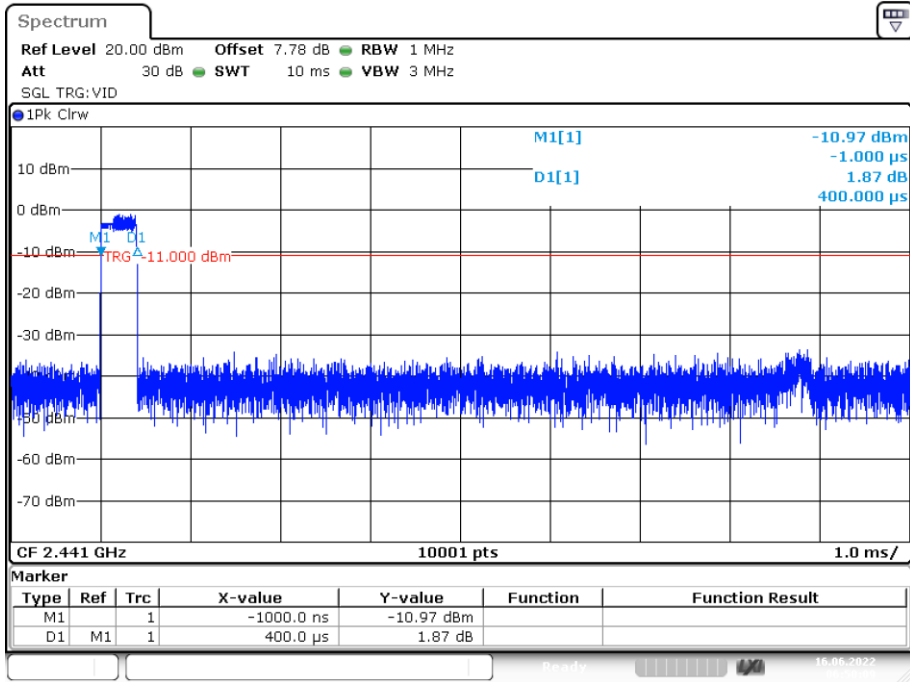

Dwell NVNT 3-DH1 2441MHz Ant1 Accumulated

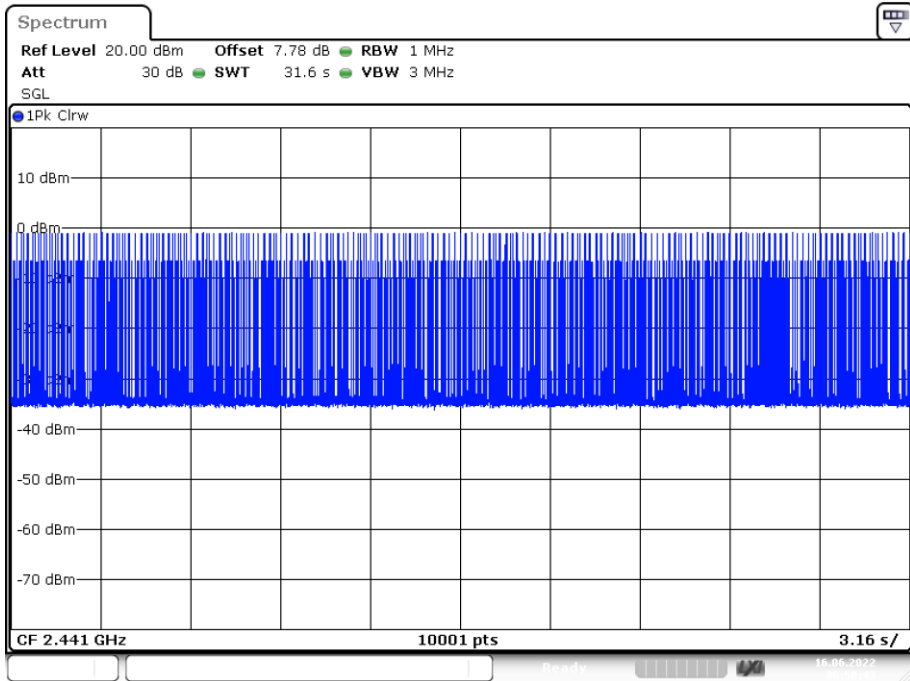

Dwell NVNT 3-DH3 2441MHz Ant1 One Burst

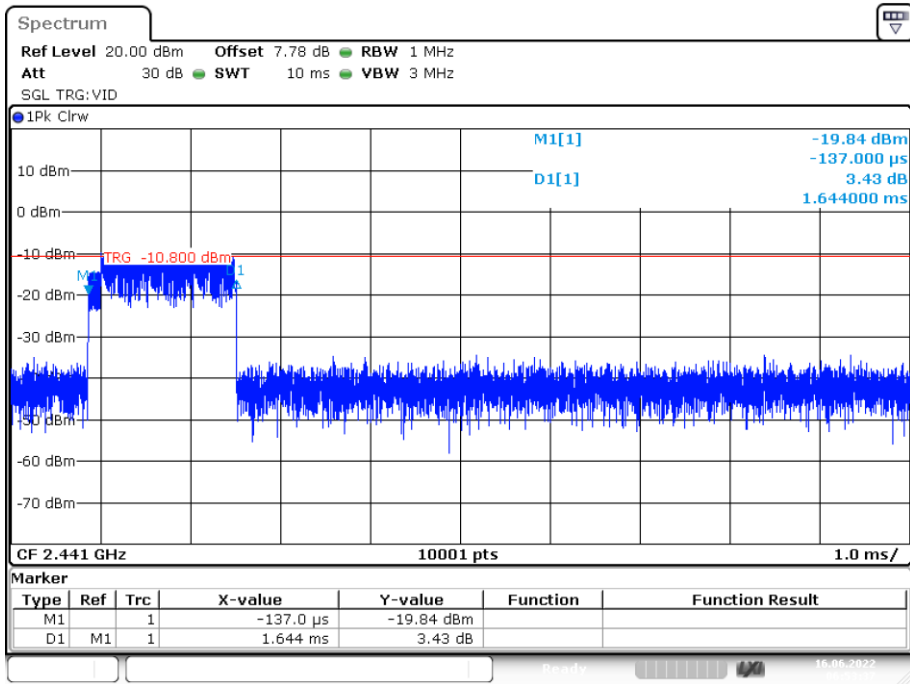

Dwell NVNT 3-DH3 2441MHz Ant1 Accumulated

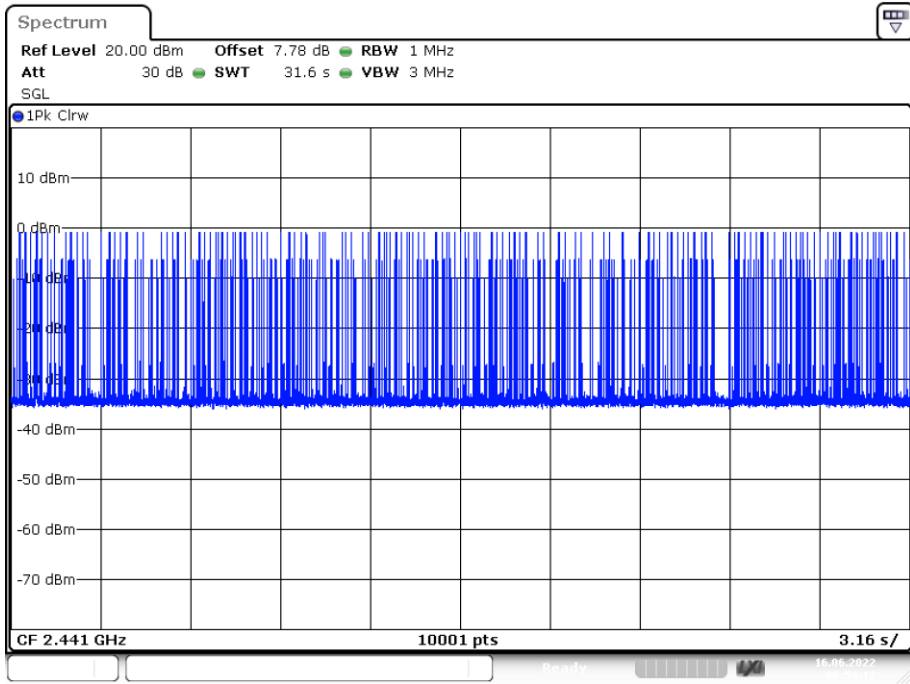

Dwell NVNT 3-DH5 2441MHz Ant1 One Burst

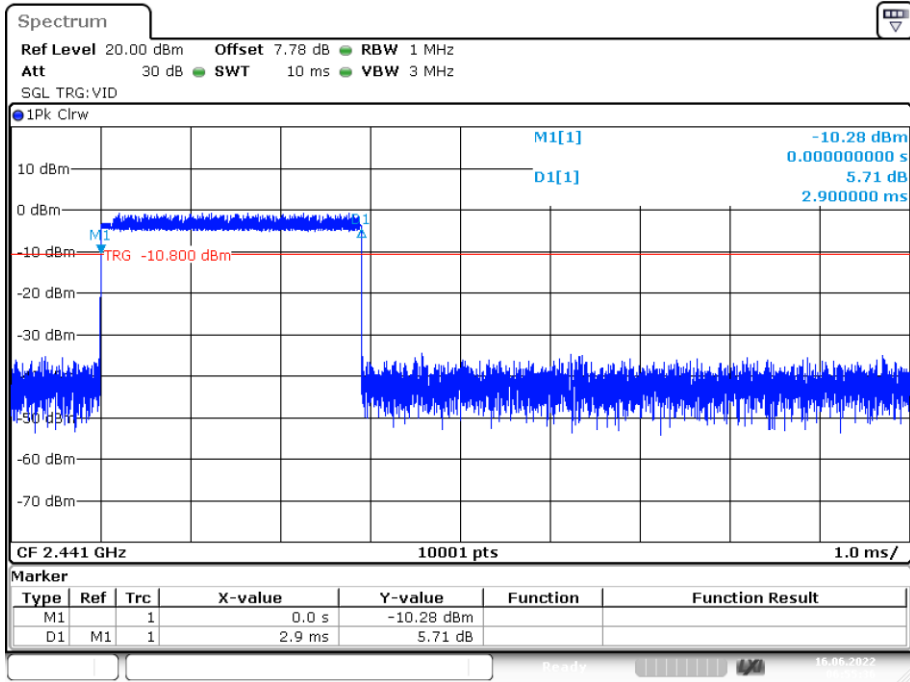

Date: 16.JUN.2022 06:55:36

Dwell NVNT 3-DH5 2441MHz Ant1 Accumulated

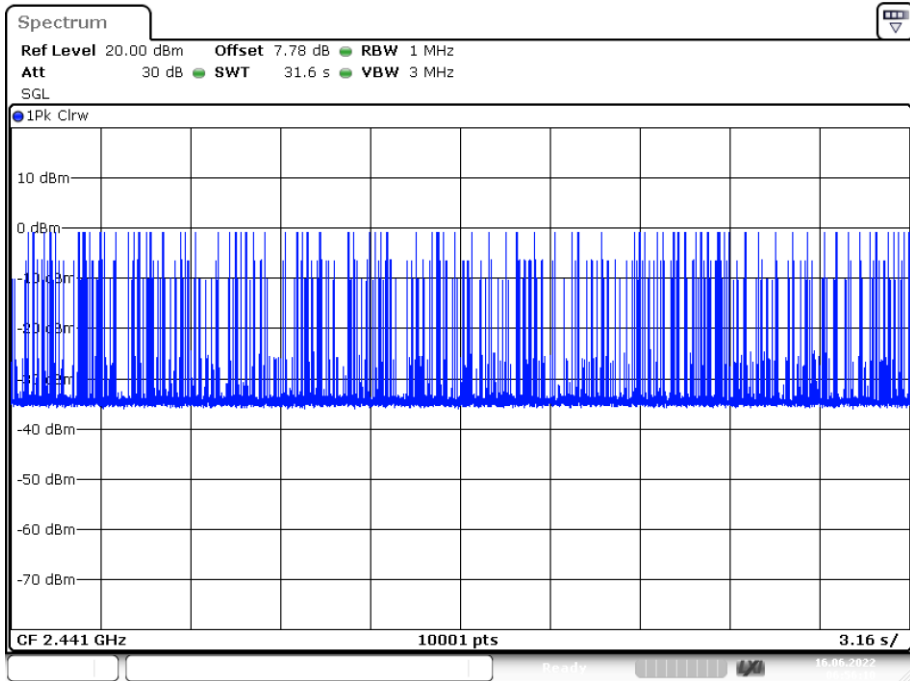

Date: 16.JUN.2022 06:56:10

8. Radiated Emissions

8.1. Limit

All the emissions appearing within 15.205 restricted frequency bands shall not exceed the limits shown in 15.209, all the other emissions shall be at least 20dB below the fundamental emissions, or comply with 15.209 limits.

15.205 Restricted frequency band

MHz	MHz	MHz	GHz
0.090 - 0.110	16.42 - 16.423	399.9 - 410	4.5 - 5.15
¹ 0.495 - 0.505	16.69475 - 16.69525	608 - 614	5.35 - 5.46
2.1735 - 2.1905	16.80425 - 16.80475	960 - 1240	7.25 - 7.75
4.125 - 4.128	25.5 - 25.67	1300 - 1427	8.025 - 8.5
4.17725 - 4.17775	37.5 - 38.25	1435 - 1626.5	9.0 - 9.2
4.20725 - 4.20775	73 - 74.6	1645.5 - 1646.5	9.3 - 9.5
6.215 - 6.218	74.8 - 75.2	1660 - 1710	10.6 - 12.7
6.26775 - 6.26825	108 - 121.94	1718.8 - 1722.2	13.25 - 13.4
6.31175 - 6.31225	123 - 138	2200 - 2300	14.47 - 14.5
8.291 - 8.294	149.9 - 150.05	2310 - 2390	15.35 - 16.2
8.362 - 8.366	156.52475 - 156.52525	2483.5 - 2500	17.7 - 21.4
8.37625 - 8.38675	156.7 - 156.9	2690 - 2900	22.01 - 23.12
8.41425 - 8.41475	162.0125 - 167.17	3260 - 3267	23.6 - 24.0
12.29 - 12.293	167.72 - 173.2	3332 - 3339	31.2 - 31.8
12.51975 - 12.52025	240 - 285	3345.8 - 3358	36.43 - 36.5
12.57675 - 12.57725	322 - 335.4	3600 - 4400	(²)

15.209 Limit

FREQUENCY MHz	DISTANCE Meters	FIELD STRENGTHS LIMIT	
		$\mu\text{V}/\text{m}$	$\text{dB}(\mu\text{V})/\text{m}$
0.009-0.490	300	2400/F(KHz)	/
0.490-1.705	30	24000/F(KHz)	/
1.705-30	30	30	29.5
30 ~ 88	3	100	40.0
88 ~ 216	3	150	43.5
216 ~ 960	3	200	46.0
960 ~ 1000	3	500	54.0
Above 1000	3	74.0 $\text{dB}(\mu\text{V})/\text{m}$ (Peak) 54.0 $\text{dB}(\mu\text{V})/\text{m}$ (Average)	

8.2. Block Diagram of Test setup

8.2.1 In 3m Anechoic Chamber Test Setup Diagram for below 30MHz

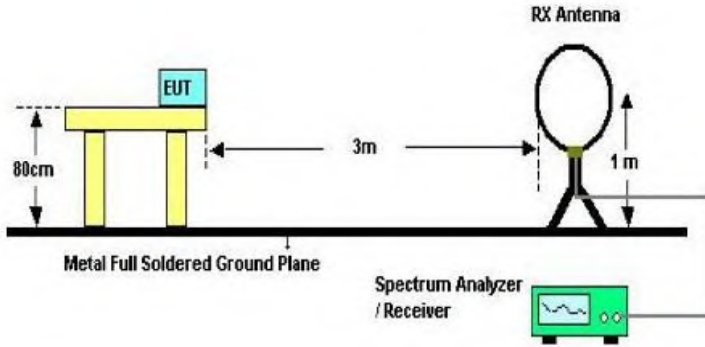

8.2.1 In 3m Anechoic Chamber Test Setup Diagram for below 1GHz

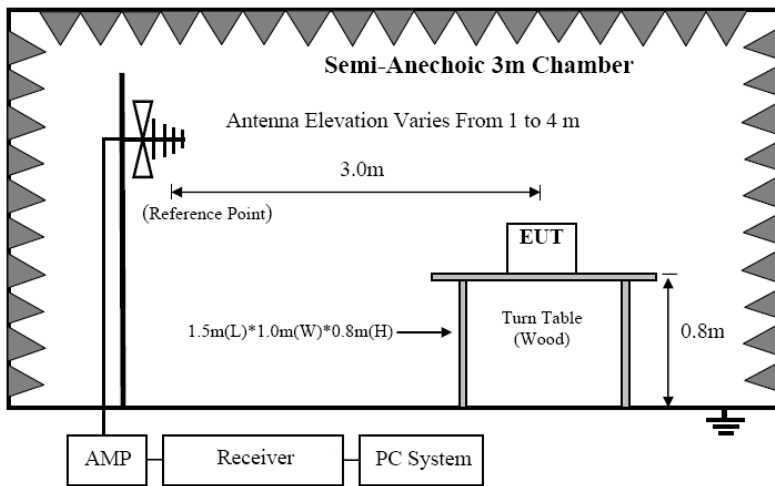

8.2.2 In 3m Anechoic Chamber Test Setup Diagram for frequency above 1GHz

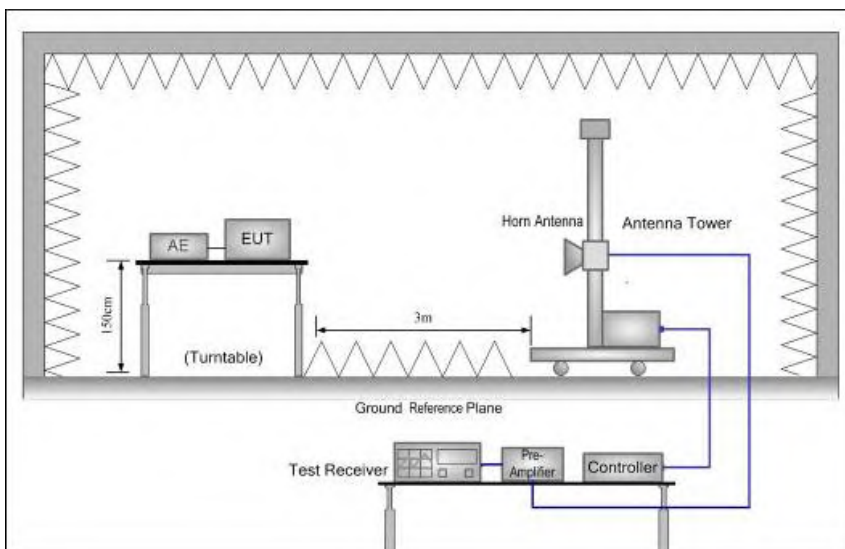

Note: For harmonic emissions test a appropriate high pass filter was inserted in the input port of AMP.

8.3. Test Procedure

- (1) EUT was placed on a non-metallic table, 80 cm above the ground plane inside a semi-anechoic chamber.
- (2) Setup EUT and simulator as shown in section 1.4 and 6.1
- (3) Test antenna was located 3m from the EUT on an adjustable mast. Below pre-scan procedure was first performed in order to find prominent radiated emissions.
 - (a) Change work frequency or channel of device if practicable.
 - (b) Change modulation type of device if practicable.
 - (c) Rotated EUT though three orthogonal axes to determine the attitude of EUT arrangement produces highest emissions
- (4) Spectrum frequency from 9KHz to 25GHz (tenth harmonic of fundamental frequency) was investigated
- (5) For final emissions measurements at each frequency of interest, the EUT were rotated and the antenna height was varied between 1m and 4m in order to maximize the emission. Measurements in both horizontal and vertical polarities were made and the data was recorded. In order to find the maximum emission, the relative positions of equipments and all of the interface cables were changed according to ANSI C63.10 :2013on Radiated Emission test.
- (6) For emissions above 1GHz, both Peak and Average level were measured with Spectrum Analyzer, and the RBW is set at 1MHz, VBW is set at 3MHz for Peak measure; RBW is set at 1MHz, VBW is set at 10Hz for Average measure.

8.4. Test Result

We have scanned the 10th harmonic from 9KHz to the EUT's highest frequency..
Detailed information please see the following page.

From 9KHz to 30MHz: Conclusion: PASS

Note: The amplitude of spurious emissions which are attenuated by more than 20dB below the permissible value has no need to be reported.

From 30MHz to 1000MHz: Conclusion: PASS

Pol Vertical

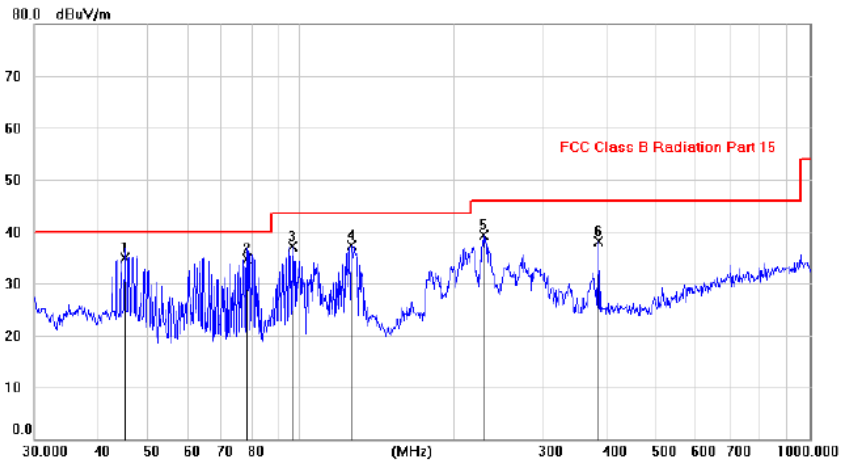

No.	Mk.	Freq.	Reading Level	Correct Factor	Measurement	Limit	Margin	Antenna Height	Table Degree	
		MHz	dBuV	dB	dBuV/m	dBuV/m	dB	cm	degree	Comment
1	*	45.1848	20.85	14.10	34.95	40.00	-5.05			QP
2		78.6335	24.67	10.00	34.67	40.00	-5.33			QP
3		96.2672	26.54	10.57	37.11	43.50	-6.39			peak
4		125.5776	24.01	13.35	37.36	43.50	-6.14			peak
5		229.2930	26.99	12.27	39.26	46.00	-6.74			peak
6		384.0663	22.11	15.99	38.10	46.00	-7.90			peak

Pol Horizontal

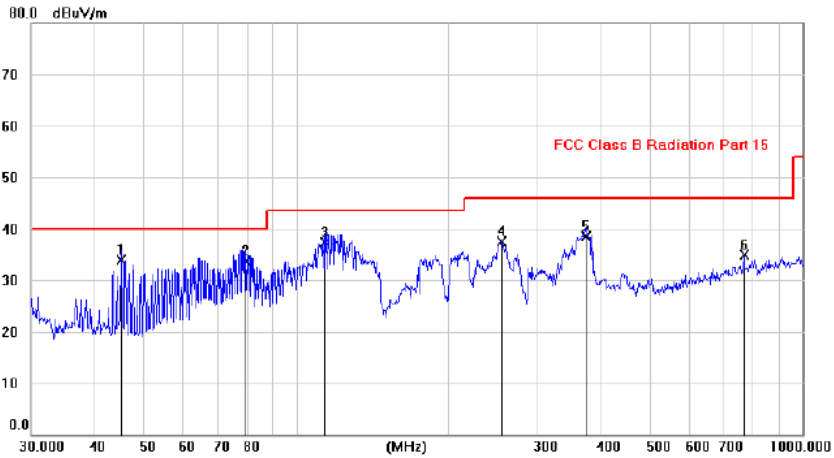

No.	Mk.	Freq.	Reading Level	Correct Factor	Measurement	Limit	Margin	Antenna Height	Table Degree	
		MHz	dBuV	dB	dBuV/m	dBuV/m	dB	cm	degree	Comment
1	*	45.2006	19.72	14.10	33.82	40.00	-6.18			QP
2		79.5486	23.78	9.89	33.67	40.00	-6.33			QP
3		113.9137	24.99	12.30	37.29	43.50	-6.21			QP
4		255.3541	24.56	12.88	37.44	46.00	-8.56			peak
5		373.4420	22.81	15.73	38.54	46.00	-7.46			QP
6		768.2092	12.24	22.68	34.92	46.00	-11.08			peak

*:Maximum data x:Over limit !:over margin

Note: Measurement=Reading Level+Correc Factor. Factor=(LISN or ISN or PLC or Current Probe)Factor+Cable

Remark: All modes have been tested, and only worst data of (GFSK) was listed in this report.

From 1G-25GHz

Test Mode: GFSK TX Low									
Freq (MHz)	Read Level (dBuV/m)	Polar (H/V)	Antenna Factor (dB/m)	Cable loss(dB)	Amp Factor (dB)	Result (dBuV/m)	Limit (dBuV/m)	Margin (dB)	Remark
4804	46.52	V	33.95	10.18	34.26	56.39	74	17.61	PK
4804	40.35	V	33.95	10.18	34.26	50.22	54	3.78	AV
7206	/	/	/	/	/	/	/	/	/
9608	/	/	/	/	/	/	/	/	/
4824	43.72	H	33.95	10.18	34.26	53.59	74	20.41	PK
4824	34.48	H	33.95	10.18	34.26	44.35	54	9.65	AV
7206	/	/	/	/	/	/	/	/	/
9608	/	/	/	/	/	/	/	/	/
Test Mode: GFSK TX Mid									
4882	44.88	V	33.93	10.2	34.29	54.72	74	19.28	PK
4882	35.70	V	33.93	10.2	34.29	45.54	54	8.46	AV
7323	/	/	/	/	/	/	/	/	/
9764	/	/	/	/	/	/	/	/	/
4882	45.24	H	33.93	10.2	34.29	55.08	74	18.92	PK
4882	34.27	H	33.93	10.2	34.29	44.11	54	9.89	AV
7323	/	/	/	/	/	/	/	/	/
9764	/	/	/	/	/	/	/	/	/
Test Mode: GFSK TX High									
4960	45.86	V	33.98	10.22	34.25	55.81	74	18.19	PK
4960	34.96	V	33.98	10.22	34.25	44.91	54	9.09	AV
7440	/	/	/	/	/	/	/	/	/
9920	/	/	/	/	/	/	/	/	/
4960	45.39	H	33.98	10.22	34.25	55.34	74	18.66	PK
4960	33.78	H	33.98	10.22	34.25	43.73	54	10.27	AV
7440	/	/	/	/	/	/	/	/	/
9920	/	/	/	/	/	/	/	/	/
Note:									
1, Result = Read level + Antenna factor + cable loss-Amp factor									
2, All the other emissions not reported were too low to read and deemed to comply with FCC limit.									

Remark: All modes have been tested, and only worst data of (GFSK) was listed in this report.

9. Band Edge Compliance

9.1. Block Diagram of Test Setup

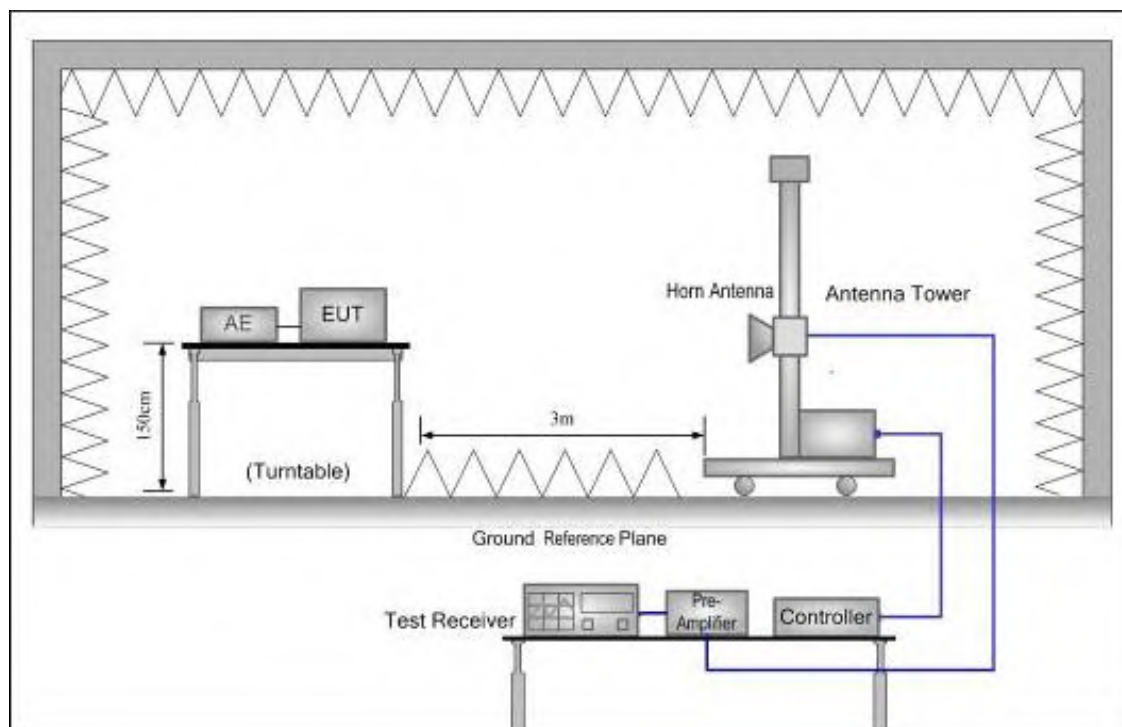

9.2. Limit

All the lower and upper band-edges emissions appearing within restricted frequency bands shall not exceed the limits shown in 15.209, all the other emissions outside operation shall be at least 20dB below the fundamental emissions, or comply with 15.209 limits.

9.3. Test Procedure

All restriction band and non- restriction band have been tested, only worse case is reported.

9.4. Test Result

PASS. (See below detailed test data)

Radiated Method:

Hopping-off

Polarization: Vertical

Test Mode:

GFSK-Low

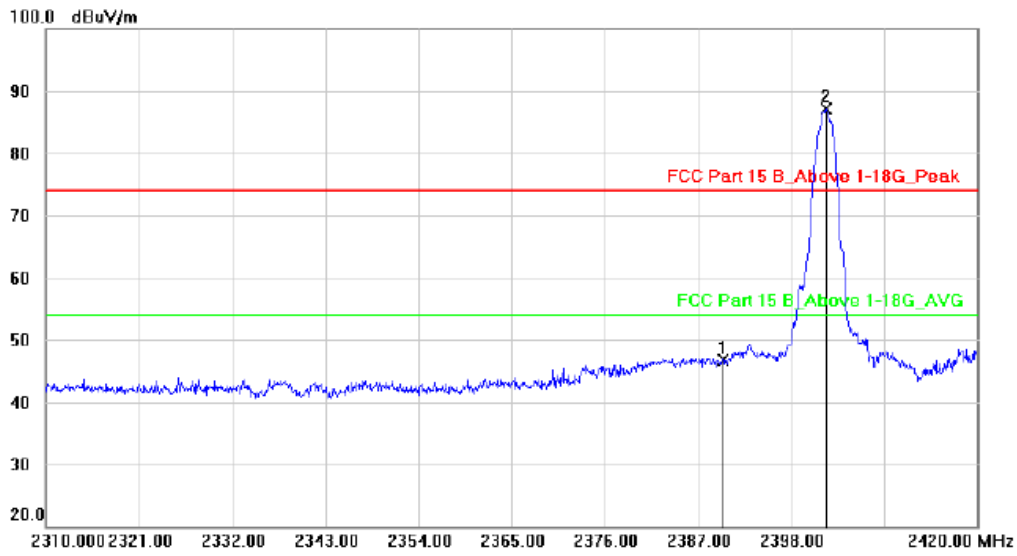

No. Mk.	Freq. MHz	Reading Level dBuV	Correct Factor dB	Measurement dBuV/m	Limit dBuV/m	Margin dB	Detector	Antenna Height cm	Table Degree	Comment
1	2390.000	50.01	-3.40	46.61	74.00	-27.39	peak			
2 *	2402.180	90.51	-3.41	87.10	74.00	13.10	peak			

Polarization: Horizontal

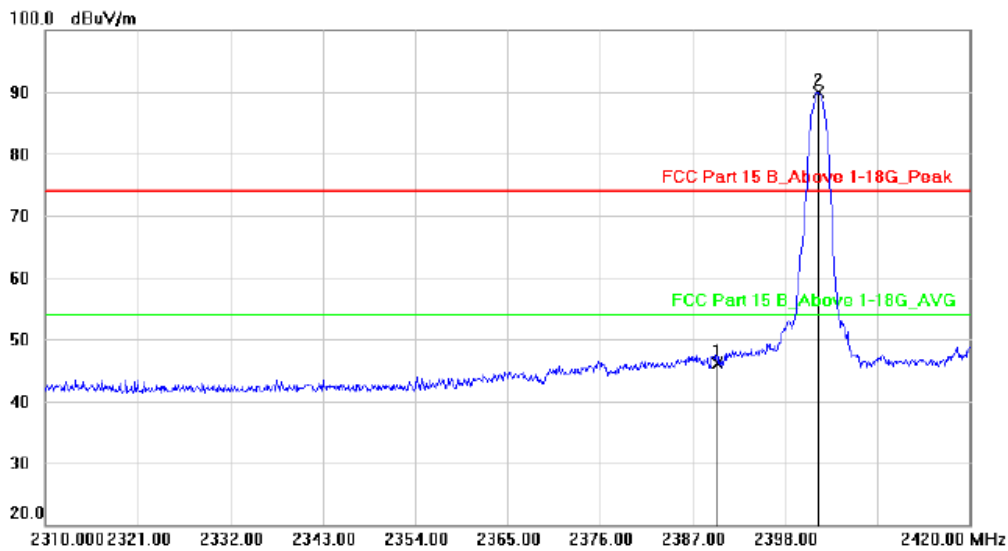

No. Mk.	Freq. MHz	Reading Level dBuV	Correct Factor dB	Measurement dBuV/m	Limit dBuV/m	Margin dB	Detector	Antenna Height cm	Table Degree	Comment
1	2390.000	49.45	-3.40	46.05	74.00	-27.95	peak			
2 *	2402.070	93.36	-3.41	89.95	74.00	15.95	peak			

Hopping-on

Polarization: Vertical

Test Mode: GFSK-Low

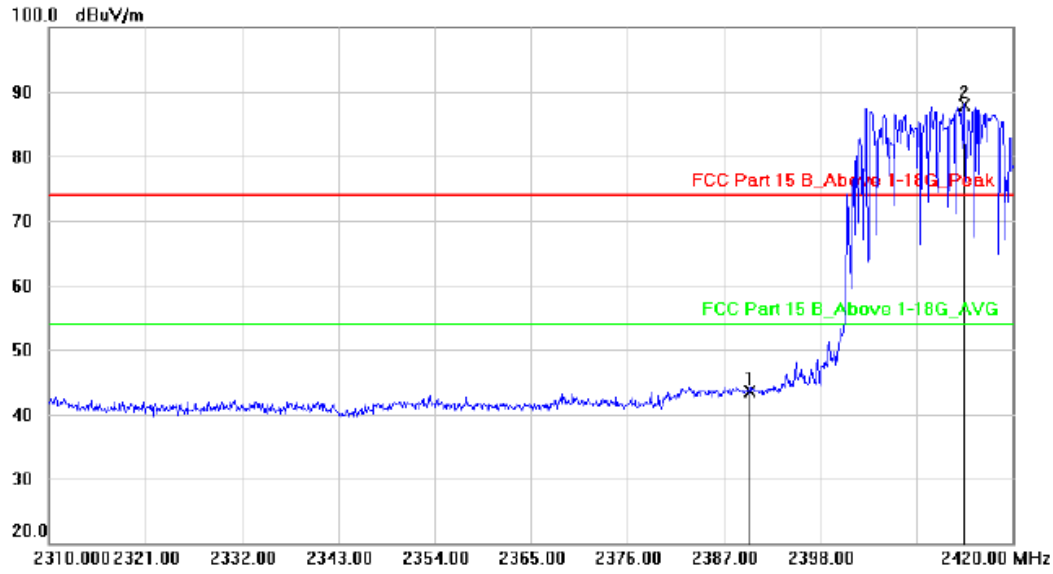

No.	Mk.	Freq.	Reading Level	Correct Factor	Measurement	Limit	Margin	Antenna Height	Table Degree	
		MHz	dBuV	dB	dBuV/m	dBuV/m	dB	cm	degree	Comment
1		2390.000	46.97	-3.40	43.57	74.00	-30.43			peak
2	*	2414.500	91.41	-3.41	88.00	74.00	14.00			peak

Polarization: Horizontal

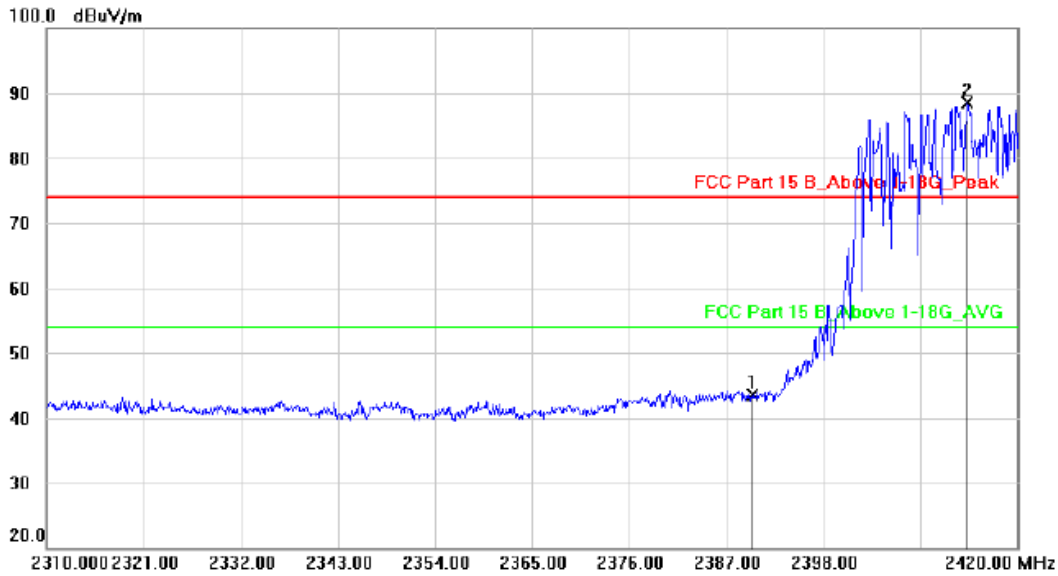

No.	Mk.	Freq.	Reading Level	Correct Factor	Measurement	Limit	Margin	Antenna Height	Table Degree	
		MHz	dBuV	dB	dBuV/m	dBuV/m	dB	cm	degree	Comment
1		2390.000	46.96	-3.40	43.56	74.00	-30.44			peak
2	*	2414.390	91.84	-3.41	88.43	74.00	14.43			peak

Hopping-off

Polarization: Vertical

Test Mode: GFSK-High

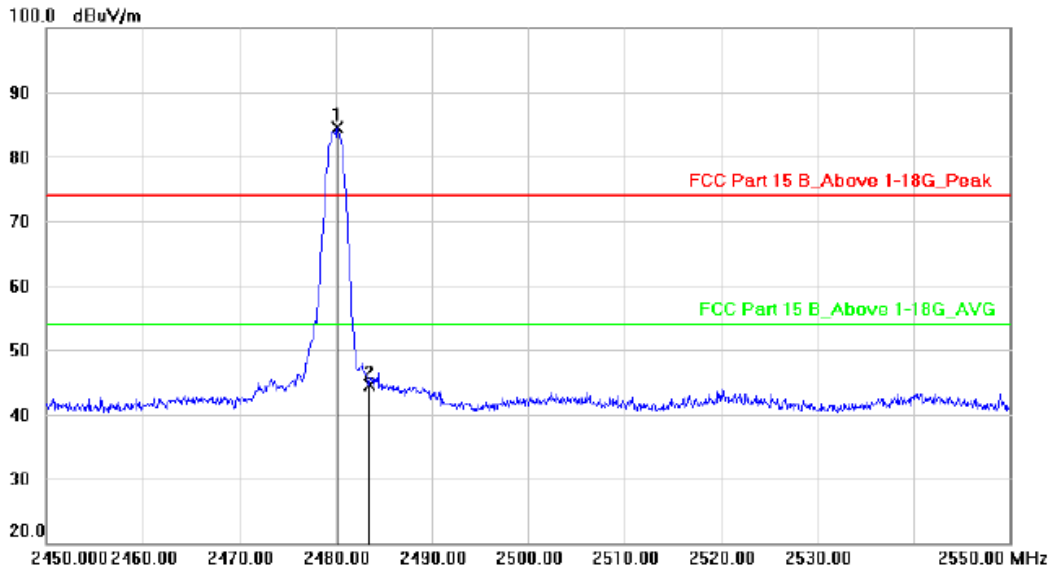

No.	Mk.	Freq.	Reading Level	Correct Factor	Measurement	Limit	Margin	Antenna Height	Table Degree
		MHz	dBuV	dB	dBuV/m	dBuV/m	dB	cm	degree
1	*	2480.200	87.90	-3.38	84.52	74.00	10.52	peak	
2		2483.500	47.86	-3.38	44.48	74.00	-29.52	peak	

Polarization: Horizontal

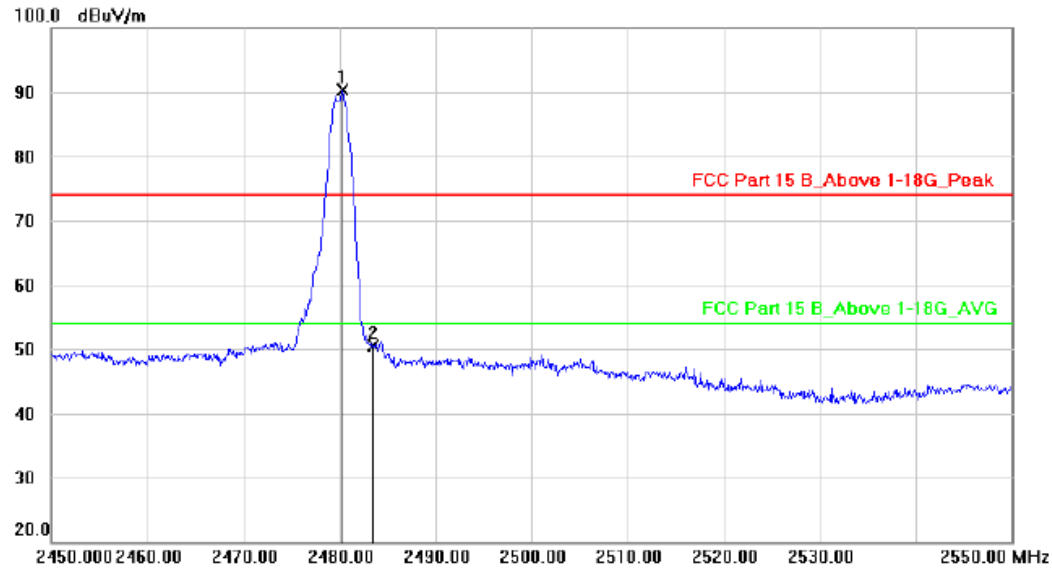

No.	Mk.	Freq.	Reading Level	Correct Factor	Measurement	Limit	Margin	Antenna Height	Table Degree
		MHz	dBuV	dB	dBuV/m	dBuV/m	dB	cm	degree
1	*	2480.300	93.60	-3.38	90.22	74.00	16.22	peak	
2		2483.500	53.82	-3.38	50.44	74.00	-23.56	peak	

Hopping-on

Polarization: Vertical

Test Mode: GFSK-High

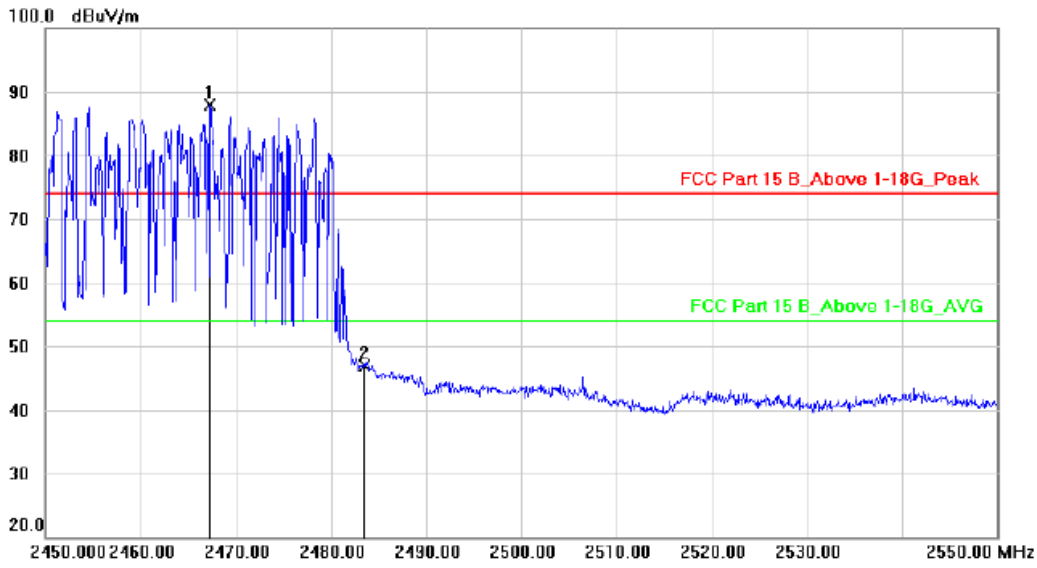

No.	Mk.	Freq.	Reading Level	Correct Factor	Measurement	Limit	Margin	Antenna Height	Table Degree
		MHz	dBuV	dB	dBuV/m	dBuV/m	dB	cm	degree
1	*	2467.300	91.25	-3.39	87.86	74.00	13.86	peak	
2		2483.500	50.26	-3.38	46.88	74.00	-27.12	peak	

Polarization: Horizontal

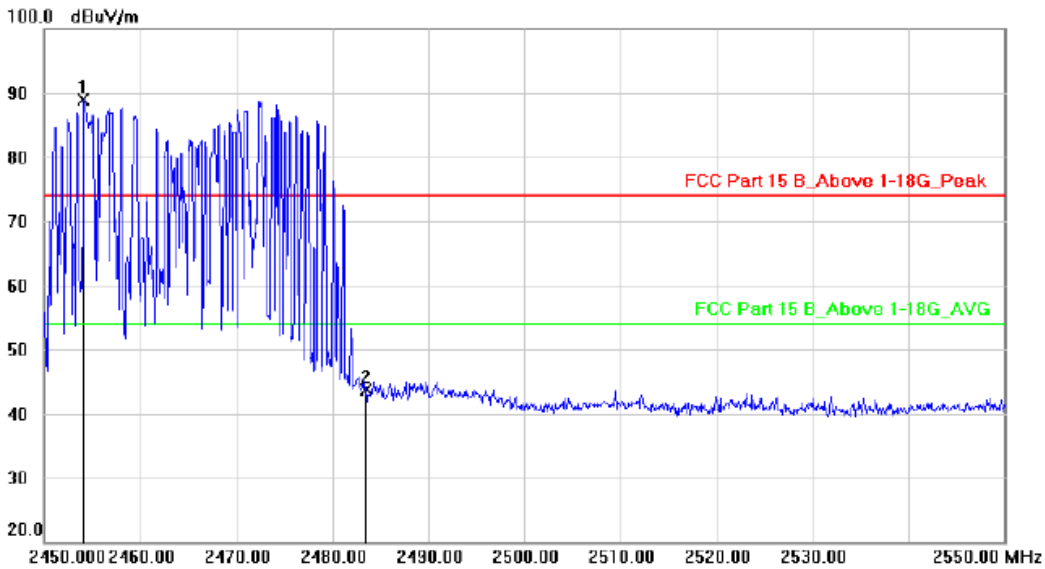

No.	Mk.	Freq.	Reading Level	Correct Factor	Measurement	Limit	Margin	Antenna Height	Table Degree
		MHz	dBuV	dB	dBuV/m	dBuV/m	dB	cm	degree
1	*	2454.100	92.28	-3.39	88.89	74.00	14.89	peak	
2		2483.500	47.17	-3.38	43.79	74.00	-30.21	peak	

hopping-on

Hopping-off

Polarization: Vertical

Test Mode: $\pi/4$ -DQPSK-Low

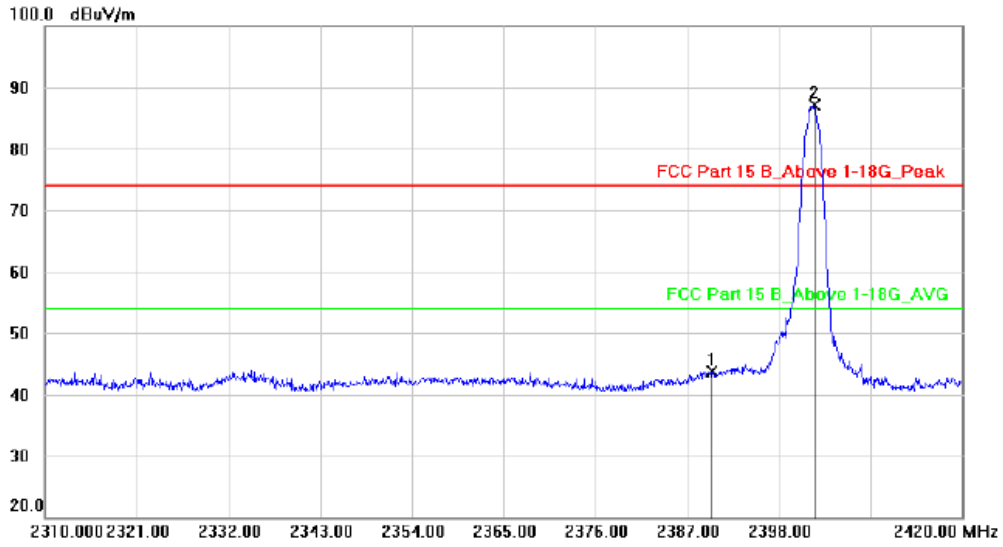

No.	Mk.	Freq.	Reading Level	Correct Factor	Measurement	Limit	Margin	Antenna Height	Table Degree	
		MHz	dBuV	dB	dBuV/m	dBuV/m	dB	cm	degree	Comment
1		2390.000	47.11	-3.40	43.71	74.00	-30.29			peak
2	*	2402.290	90.48	-3.41	87.07	74.00	13.07			peak

Polarization: Horizontal

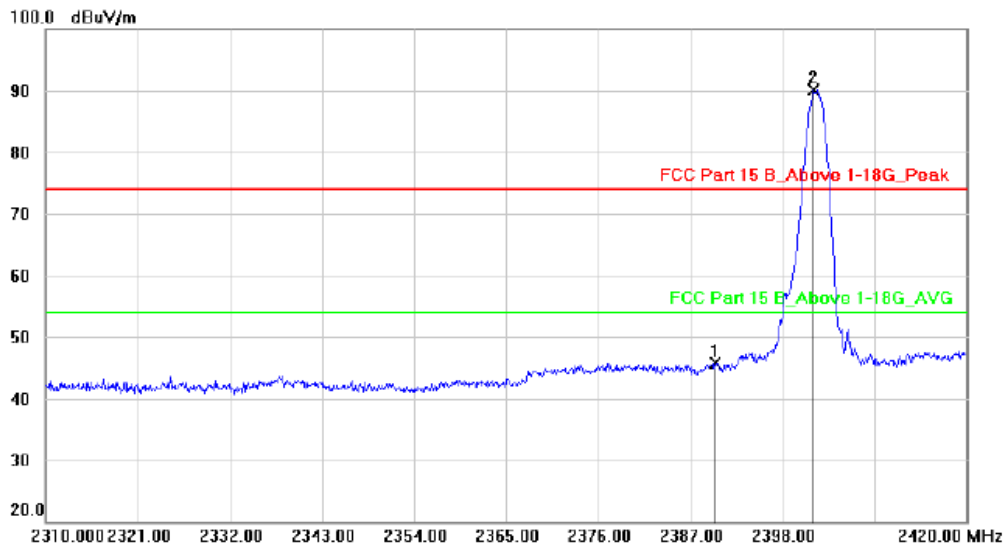

No.	Mk.	Freq.	Reading Level	Correct Factor	Measurement	Limit	Margin	Antenna Height	Table Degree	
		MHz	dBuV	dB	dBuV/m	dBuV/m	dB	cm	degree	Comment
1		2390.000	49.18	-3.40	45.78	74.00	-28.22			peak
2	*	2401.740	93.44	-3.41	90.03	74.00	16.03			peak

Hopping-on

Polarization: Vertical

Test Mode: $\pi/4$ -DQPSK-Low

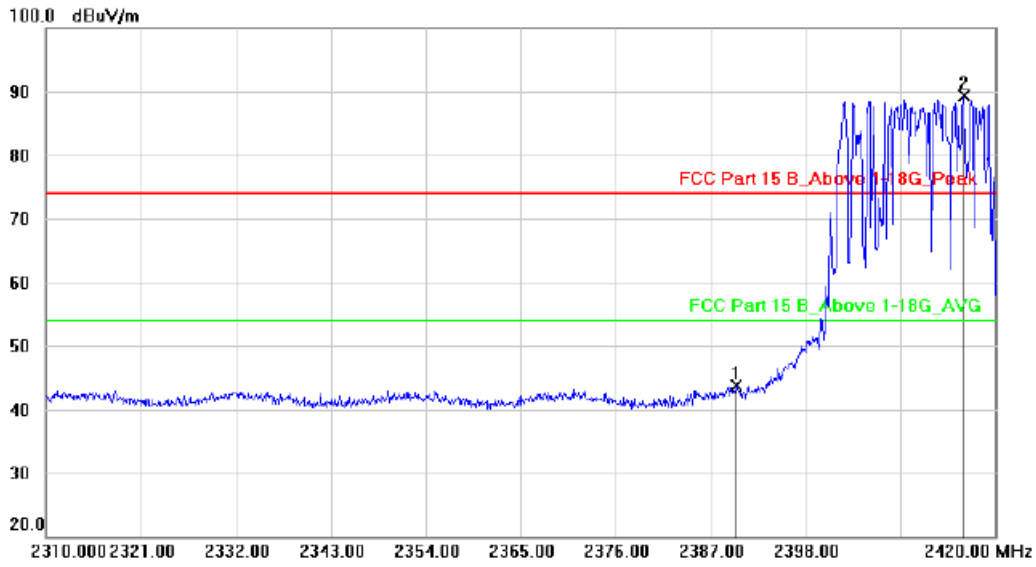

No.	Mk.	Freq.	Reading Level	Correct Factor	Measurement	Limit	Margin	Antenna Height	Table Degree	
		MHz	dBuV	dB	dBuV/m	dBuV/m	dB	cm	degree	Comment
1		2390.000	47.07	-3.40	43.67	74.00	-30.33			peak
2	*	2416.370	92.80	-3.41	89.39	74.00	15.39			peak

Polarization: Horizontal

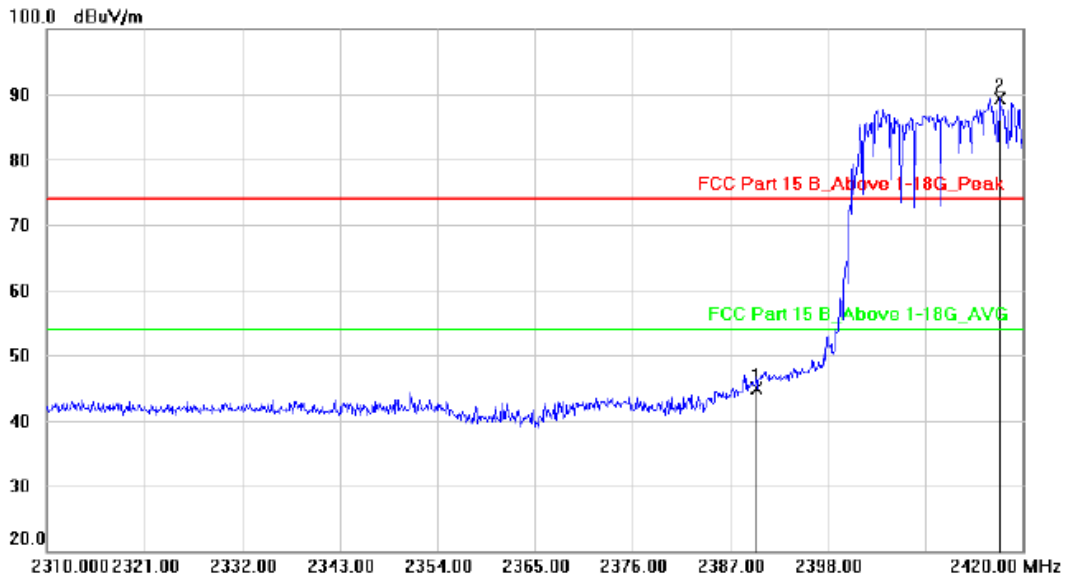

No.	Mk.	Freq.	Reading Level	Correct Factor	Measurement	Limit	Margin	Antenna Height	Table Degree	
		MHz	dBuV	dB	dBuV/m	dBuV/m	dB	cm	degree	Comment
1		2390.000	48.29	-3.40	44.89	74.00	-29.11			peak
2	*	2417.360	92.75	-3.41	89.34	74.00	15.34			peak

Hopping-off

Polarization: Vertical

Test Mode: $\pi/4$ -DQPSK-High

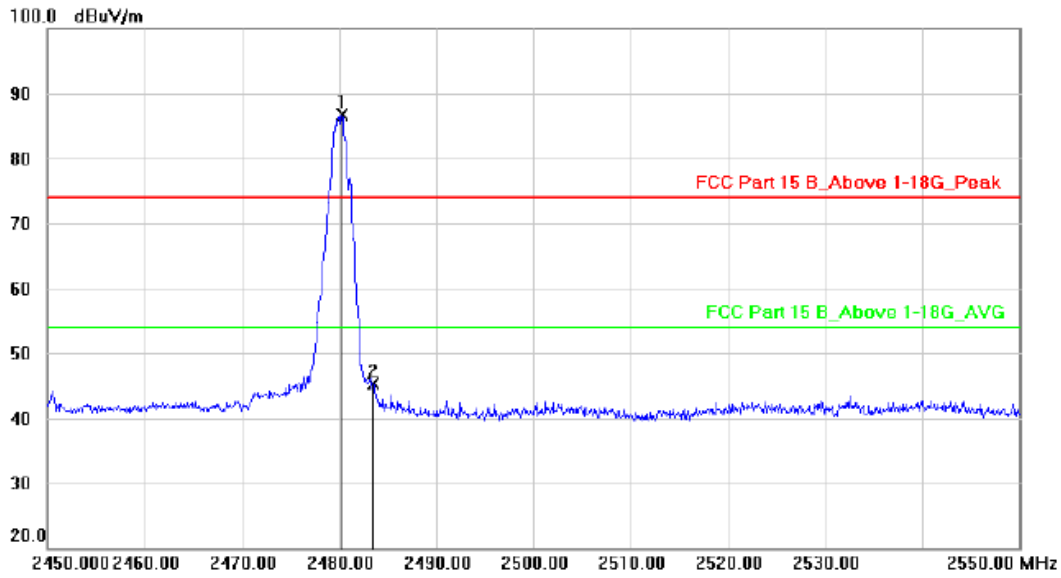

No.	Mk.	Freq.	Reading Level	Correct Factor	Measurement	Limit	Margin	Antenna Height	Table Degree	
		MHz	dBuV	dB	dBuV/m	dBuV/m	dB	cm	degree	Comment
1	*	2480.300	90.04	-3.38	86.66	74.00	12.66			peak
2		2483.500	48.71	-3.38	45.33	74.00	-28.67			peak

Polarization: Horizontal

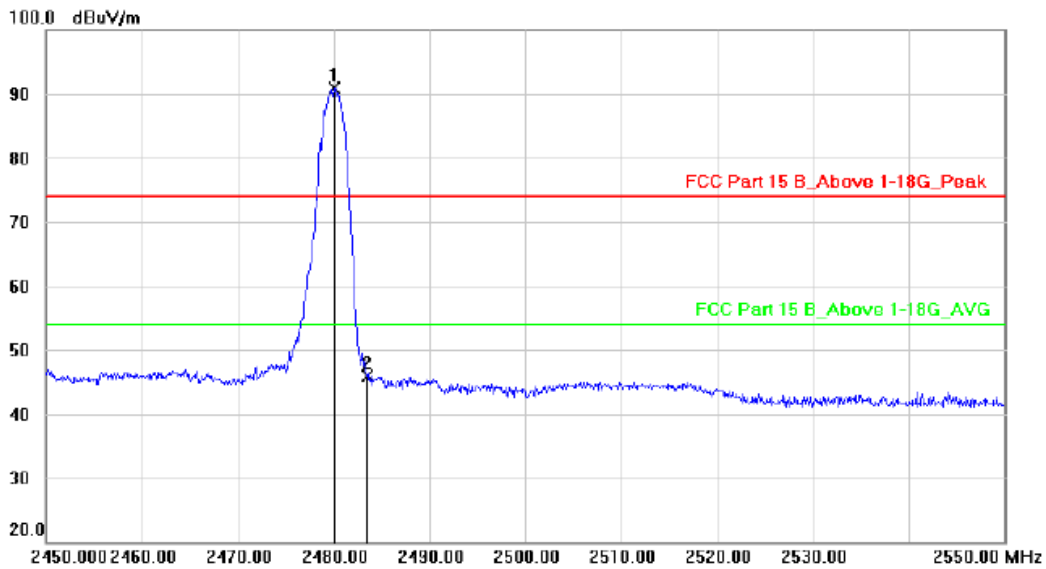

No.	Mk.	Freq.	Reading Level	Correct Factor	Measurement	Limit	Margin	Antenna Height	Table Degree	
		MHz	dBuV	dB	dBuV/m	dBuV/m	dB	cm	degree	Comment
1	*	2480.000	94.32	-3.38	90.94	74.00	16.94			peak
2		2483.500	49.36	-3.38	45.98	74.00	-28.02			peak

Hopping-on

Polarization: Vertical

Test Mode: $\pi/4$ -DQPSK-High

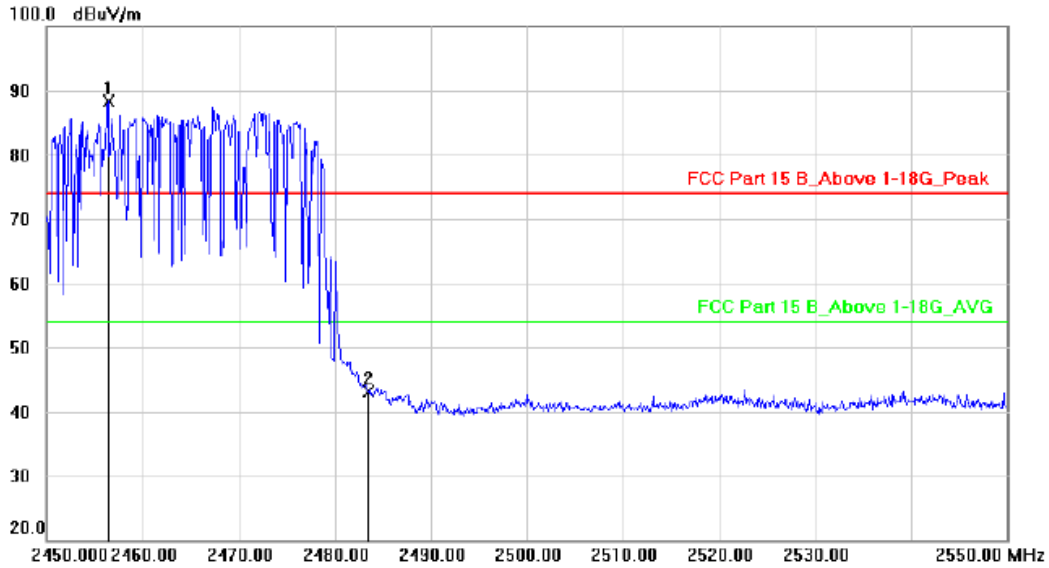

No.	Mk.	Freq.	Reading Level	Correct Factor	Measurement	Limit	Margin	Antenna Height	Table Degree	Detector	Comment
		MHz	dBuV	dB	dBuV/m	dBuV/m	dB	cm	degree		
1	*	2456.400	91.72	-3.39	88.33	74.00	14.33			peak	
2		2483.500	46.42	-3.38	43.04	74.00	-30.96			peak	

Polarization: Horizontal

Test Mode:

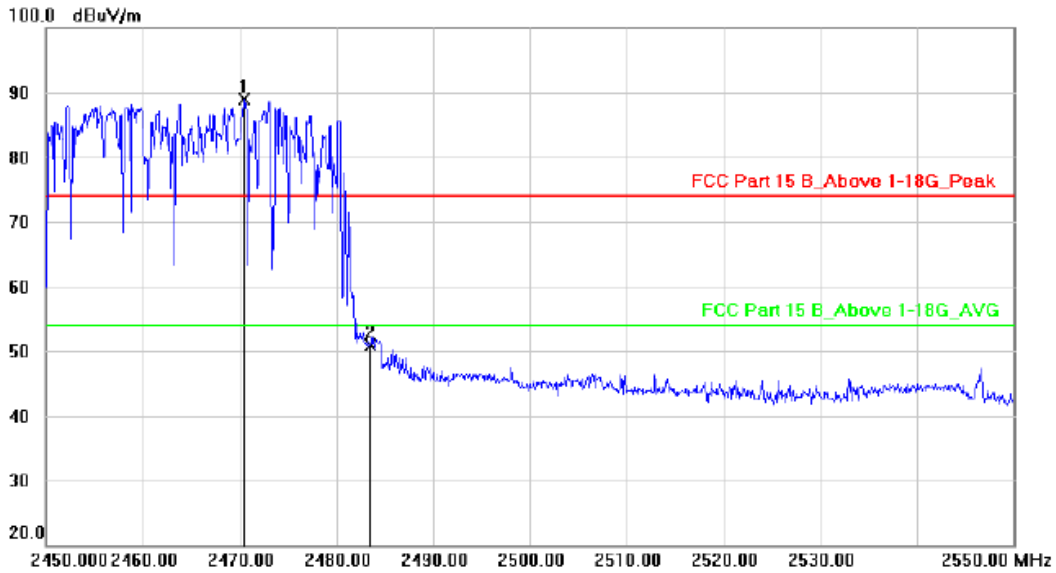

No.	Mk.	Freq.	Reading Level	Correct Factor	Measurement	Limit	Margin	Antenna Height	Table Degree	Detector	Comment
		MHz	dBuV	dB	dBuV/m	dBuV/m	dB	cm	degree		
1	*	2470.500	92.38	-3.39	88.99	74.00	14.99			peak	
2		2483.500	54.24	-3.38	50.86	74.00	-23.14			peak	

hopping-on

Hopping-off

Polarization: Vertical

Test Mode: 8DPSK-Low

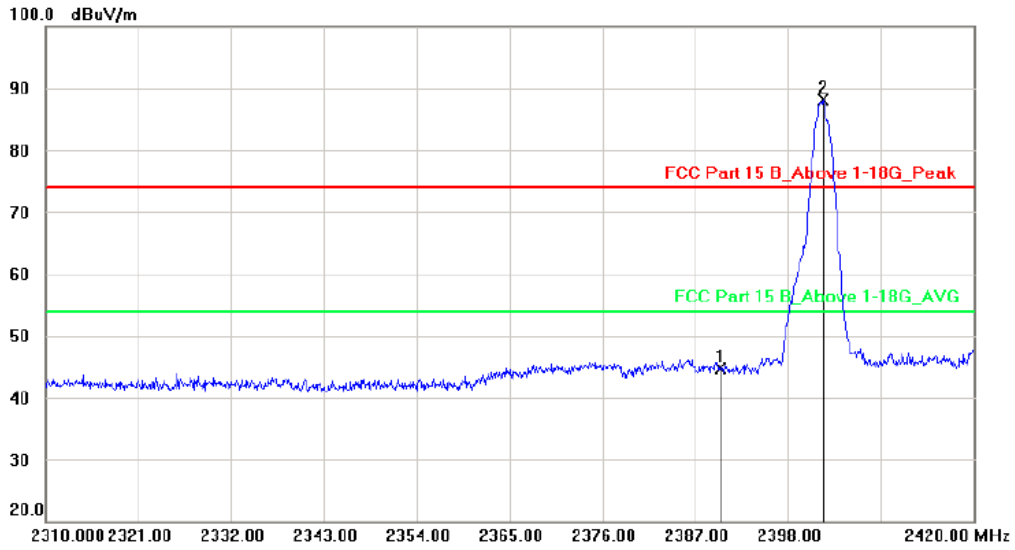

No.	Mk.	Freq.	Reading Level	Correct Factor	Measurement	Limit	Margin	Antenna Height	Table Degree
		MHz	dBuV	dB	dBuV/m	dBuV/m	dB	cm	degree
1		2390.000	48.01	-3.40	44.61	74.00	-29.39	peak	
2	*	2402.180	91.51	-3.41	88.10	74.00	14.10	peak	

Polarization: Horizontal

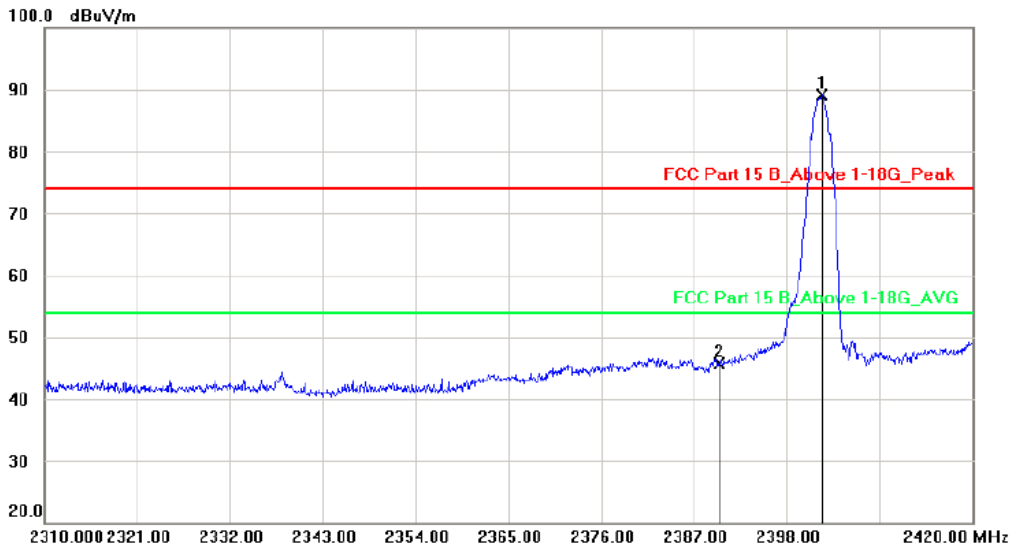

No.	Mk.	Freq.	Reading Level	Correct Factor	Measurement	Limit	Margin	Antenna Height	Table Degree
		MHz	dBuV	dB	dBuV/m	dBuV/m	dB	cm	degree
1	*	2402.180	92.42	-3.41	89.01	74.00	15.01	peak	
2		2390.000	49.18	-3.40	45.78	74.00	-28.22	peak	

Hopping-off

Polarization: Vertical

Test Mode: 8DPSK-High

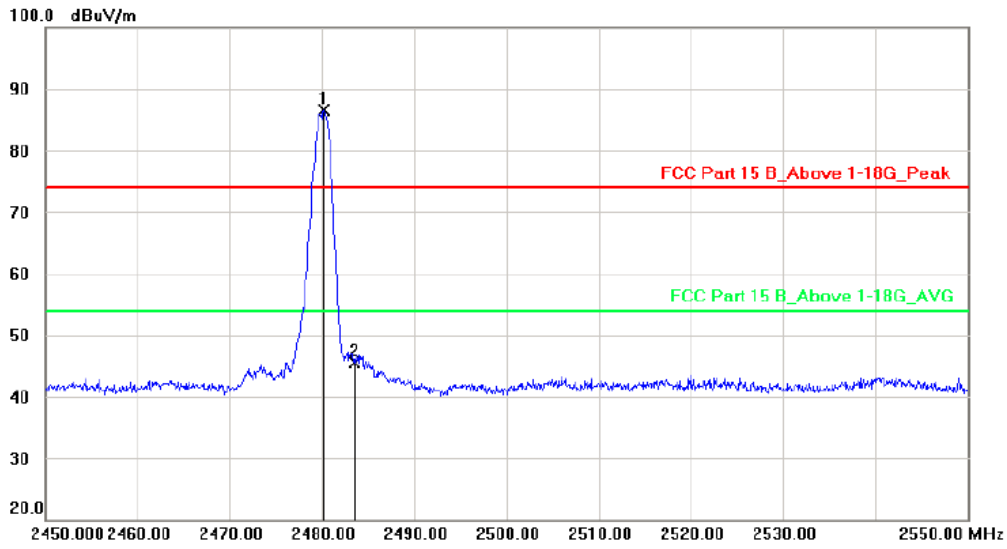

No.	Mk.	Freq. MHz	Reading Level dBuV	Correct Factor dB	Measure- ment dBuV/m	Limit dBuV/m	Margin dB	Detector	Antenna Height cm	Table Degree	Comment
1	*	2480.200	89.90	-3.38	86.52	74.00	12.52	peak			
2		2483.500	48.86	-3.38	45.48	74.00	-28.52	peak			

Polarization: Horizontal

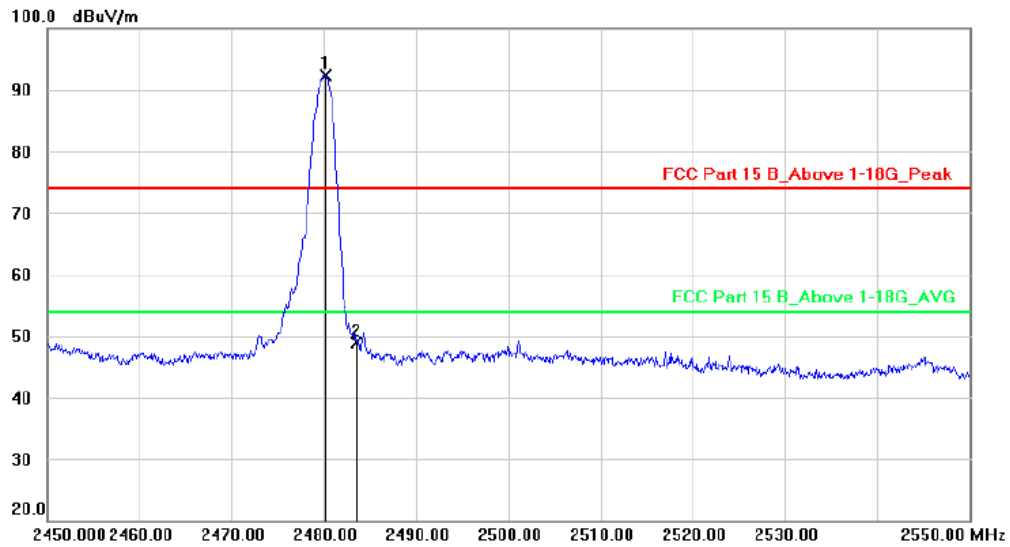

No.	Mk.	Freq. MHz	Reading Level dBuV	Correct Factor dB	Measure- ment dBuV/m	Limit dBuV/m	Margin dB	Detector	Antenna Height cm	Table Degree	Comment
1	*	2480.200	95.75	-3.38	92.37	74.00	18.37	peak			
2		2483.500	52.32	-3.38	48.94	74.00	-25.06	peak			

Hopping-on

Polarization: Vertical

Test Mode: 8DPSK-Low

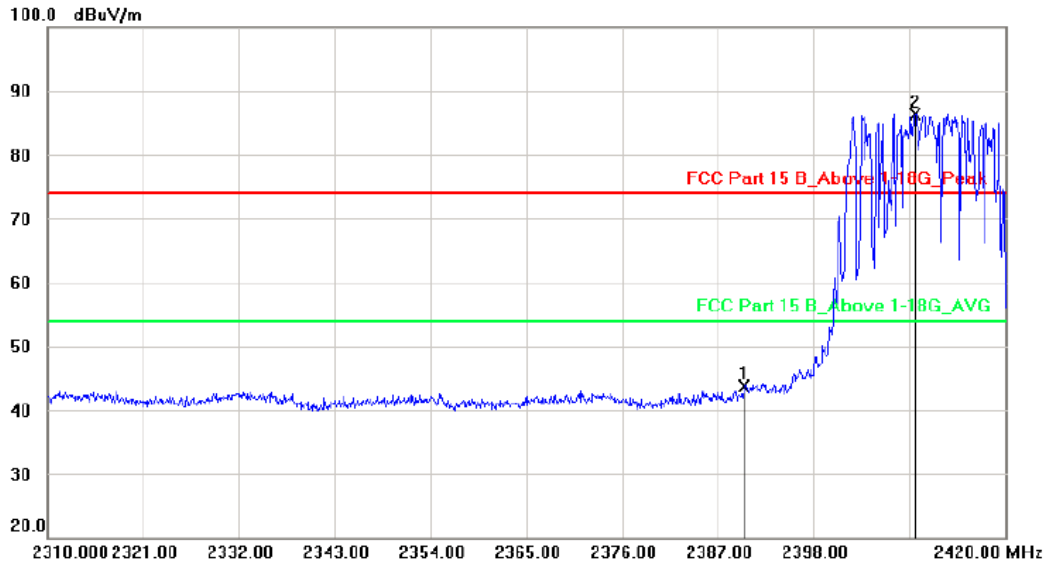

No.	Mk.	Freq. MHz	Reading Level dBuV	Correct Factor dB	Measure- ment dBuV/m	Limit dBuV/m	Margin dB	Detector	Antenna Height cm	Table Degree	Comment
1		2390.000	47.07	-3.40	43.67	74.00	-30.33	peak			
2	*	2409.660	89.73	-3.40	86.33	74.00	12.33	peak			

Polarization: Horizontal

Test Mode:

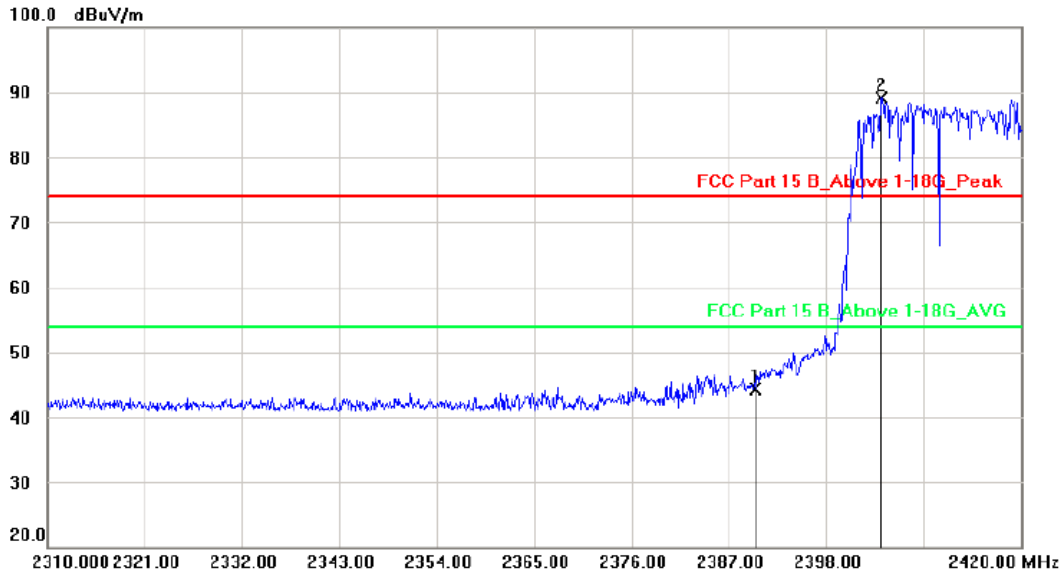

No.	Mk.	Freq. MHz	Reading Level dBuV	Correct Factor dB	Measure- ment dBuV/m	Limit dBuV/m	Margin dB	Detector	Antenna Height cm	Table Degree	Comment
1		2390.000	47.79	-3.40	44.39	74.00	-29.61	peak			
2	*	2404.270	92.57	-3.41	89.16	74.00	15.16	peak			

hopping-on

Hopping-on

Polarization: Vertical

Test Mode: 8DPSK-High

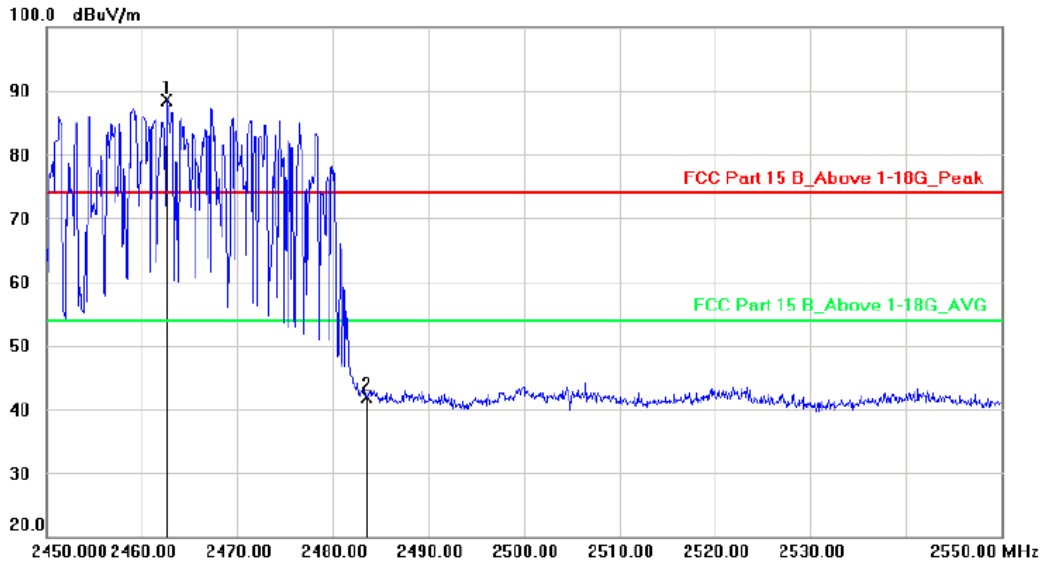

No.	Mk.	Freq.	Reading Level	Correct Factor	Measurement	Limit	Margin	Antenna Height	Table Degree	
		MHz	dBuV	dB	dBuV/m	dBuV/m	dB	cm	degree	Comment
1	*	2462.600	91.90	-3.40	88.50	74.00	14.50			peak
2		2483.500	45.26	-3.38	41.88	74.00	-32.12			peak

Polarization: Horizontal

Test Mode:

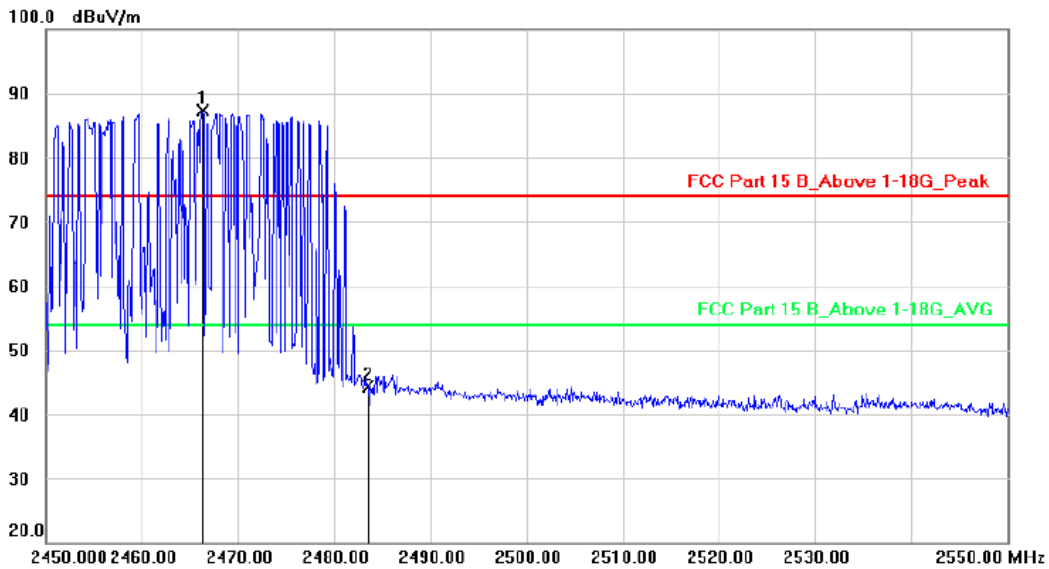

No.	Mk.	Freq.	Reading Level	Correct Factor	Measurement	Limit	Margin	Antenna Height	Table Degree	
		MHz	dBuV	dB	dBuV/m	dBuV/m	dB	cm	degree	Comment
1	*	2466.300	90.67	-3.39	87.28	74.00	13.28			peak
2		2483.500	47.67	-3.38	44.29	74.00	-29.71			peak

hopping-on

Conducted Method

Band Edge NVNT 1-DH1 2402MHz Ant1 Hopping Emission

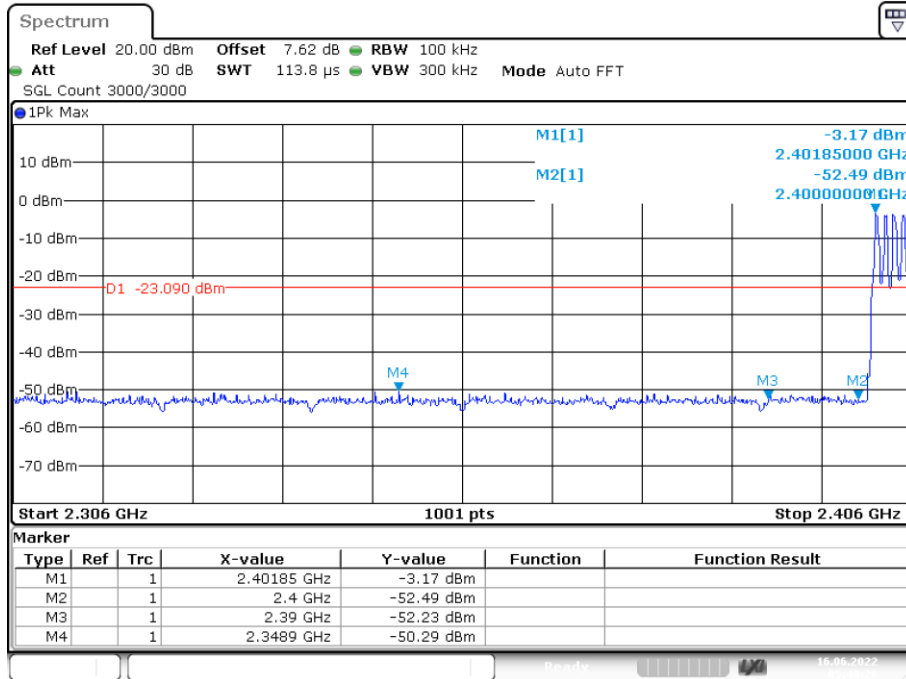

Date: 16.JUN.2022 05:49:26

Band Edge NVNT 1-DH1 2402MHz Ant1 No-Hopping Emission

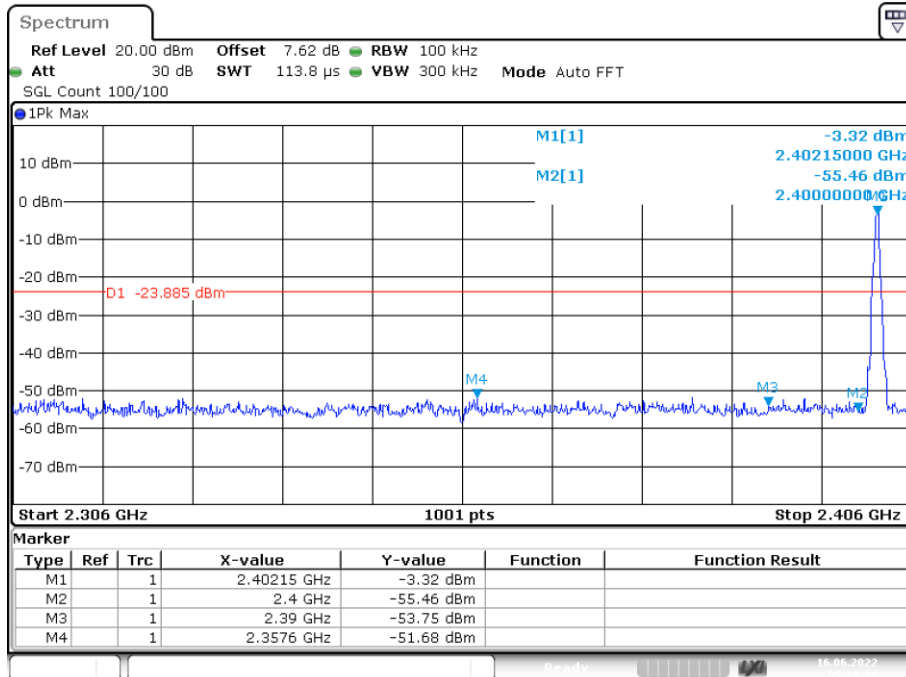

Date: 16.JUN.2022 05:18:59

Band Edge NVNT 1-DH1 2480MHz Ant1 Hopping Emission

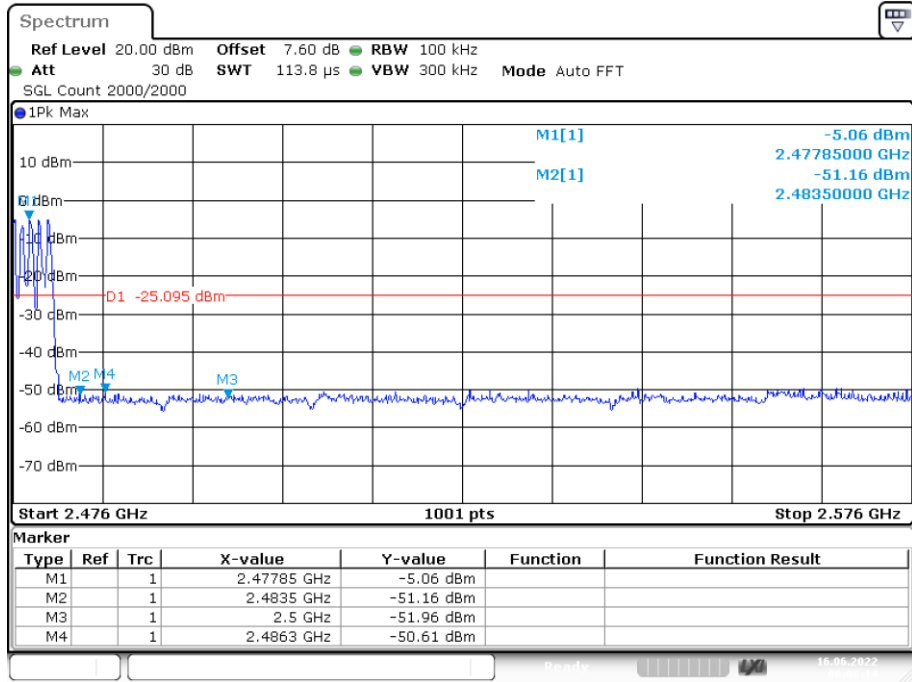

Date: 16.JUN.2022 06:06:14

Band Edge NVNT 1-DH1 2480MHz Ant1 No-Hopping Emission

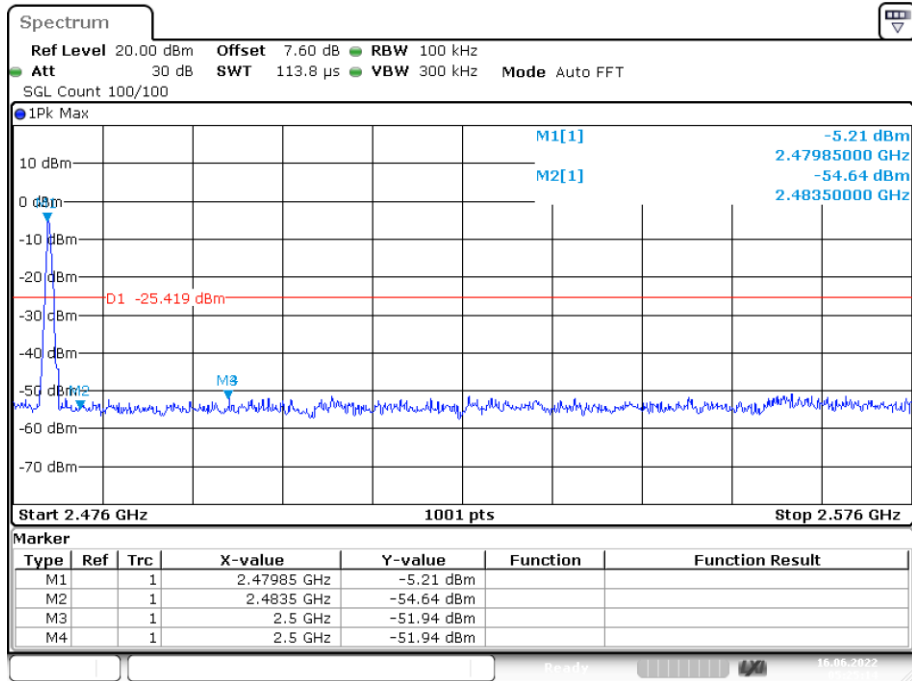

Date: 16.JUN.2022 05:25:13

Band Edge NVNT 2-DH1 2402MHz Ant1 Hopping Emission

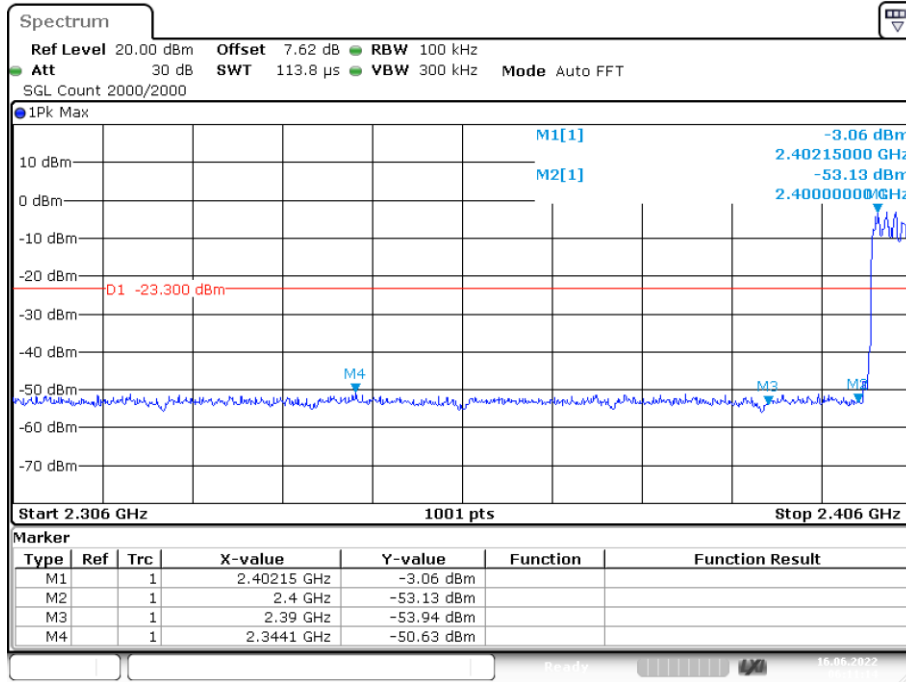

Date: 16.JUN.2022 06:11:14

Band Edge NVNT 2-DH1 2402MHz Ant1 No-Hopping Emission

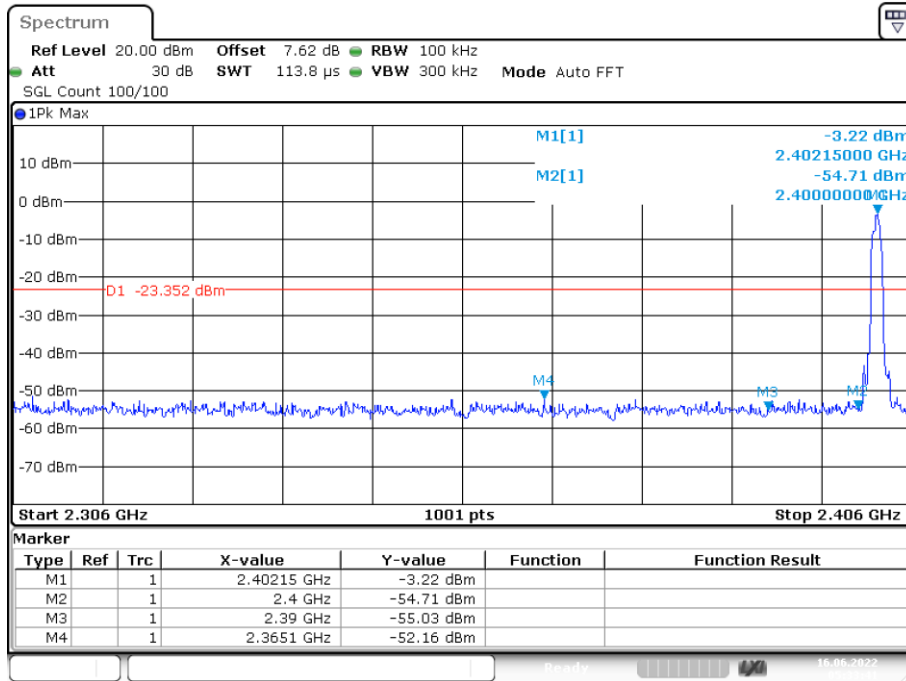

Date: 16.JUN.2022 05:33:41

Band Edge NVNT 2-DH1 2480MHz Ant1 Hopping Emission

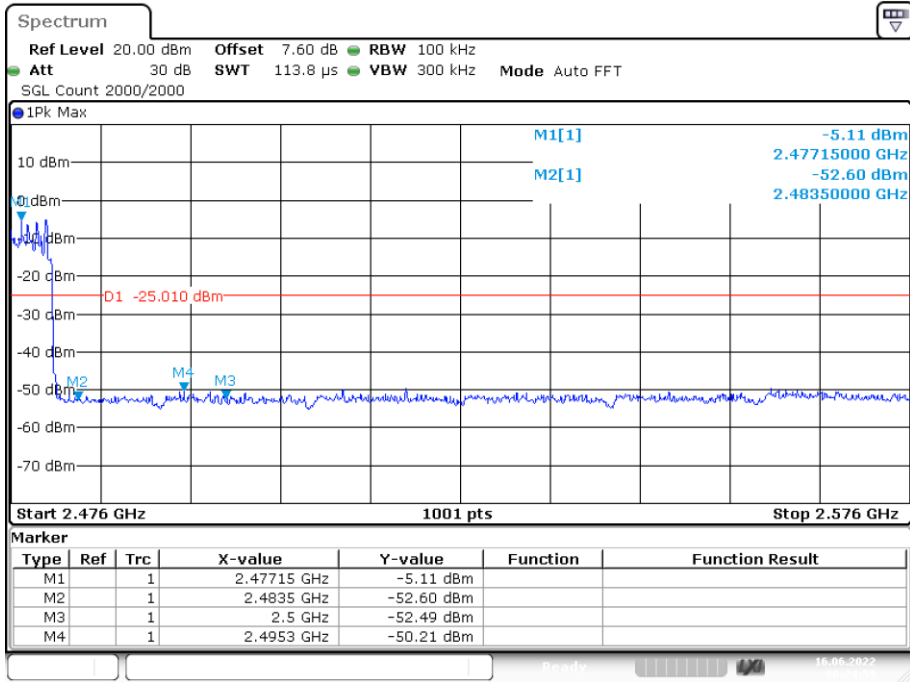

Band Edge NVNT 2-DH1 2480MHz Ant1 No-Hopping Emission

