



FSC-BT958

5.0 Dual Mode Bluetooth Module Datasheet

Version 1.0

Copyright © 2013-2021 Feasycom Technology. All Rights Reserved.

Feasycom Technology reserves the right to make corrections, modifications, and other changes to its products, documentation and services at anytime. Customers should obtain the newest relevant information before placing orders. To minimize customer product risks, customers should provide adequate design and operating safeguards. Without written permission from Feasycom Technology, reproduction, transfer, distribution or storage of part or all of the contents in this document in any form is prohibited.

Revision History

Version	Date	Notes	
1.0	2021/04/20	Initial Version	Fish

Contact Us

Shenzhen Feasycom Technology Co.,LTD

Email: sales@feasycom.com

Address: Room 2004-2005,20th Floor,Huichao Technology Building,Jinhai Road,
Xixiang ,Baoan District,Shenzhen,518100,China.

Tel: 86-755-27924639, 86-755-23062695

Contents

1. INTRODUCTION	4
2. GENERAL SPECIFICATION	5
3. HARDWARE SPECIFICATION	5
3.1 BLOCK DIAGRAM AND PIN DIAGRAM	5
3.2 PIN DEFINITION DESCRIPTIONS	6
4. PHYSICAL INTERFACE	8
4.1 POWER SUPPLY	8
4.2 AUDIO INTERFACES	8
4.2.1 <i>Microphone Input & line IN</i>	8
4.2.2 <i>SPEAKER</i>	8
4.3 RESET	8
4.4 RF INTERFACE	8
4.5 SERIAL INTERFACES	9
4.5.1 <i>UART</i>	9
5. ELECTRICAL CHARACTERISTICS	10
5.1 ABSOLUTE MAXIMUM RATINGS	10
5.2 RECOMMENDED OPERATING CONDITIONS	10
5.3 AUDIO CODEC ELECTRICAL CHARACTERISTICS	10
6. MSL & ESD	11
7. RECOMMENDED TEMPERATURE REFLOW PROFILE	11
8. MECHANICAL DETAILS	13
8.1 MECHANICAL DETAILS	13
9. HARDWARE INTEGRATION SUGGESTIONS	14
9.1 SOLDERING RECOMMENDATIONS	14
9.2 LAYOUT GUIDELINES (INTERNAL ANTENNA)	14
9.3 LAYOUT GUIDELINES (EXTERNAL ANTENNA)	15
9.3.1 <i>Antenna Connection and Grounding Plane Design</i>	15
10. PRODUCT PACKAGING INFORMATION	16
10.1 DEFAULT PACKING	16
10.2 PACKING BOX (OPTIONAL)	17
11. APPLICATION SCHEMATIC	18

1. INTRODUCTION

Overview

FSC-BT958 is a multimedia system-on-chip solution with Bluetooth 5.0 dual-mode and highly integrated, dedicated to music and audio applications.

Integrating all necessary electronic components (including baseband, Bluetooth transceiver, power management) into a single system-on-chip, it provides a best-in-class bill of materials, space requirements, and cost/function ratio for Bluetooth music and audio applications.

By default, Feasycom standard firmware is built-in, and customized firmware is also available.

FSC-BT958 is a suitable product for designers who want to add wireless functions to their products.

Features

- Compliant with Bluetooth 5.0 dual mode specification
- High power output(10dBm) Class2 and Class3 transmission supported
- UART programming and data interface (baudrate can up to 921600bps)
- Postage stamp sized form factor
- A2DP v1.3/AVRCP v1.5/HFP v1.6
- Internal LPO support for low power mode
- Echo Cancellation
- 24 bit audio processing
- HiFi Stereo Audio DAC:
 - 120Db 2NR
 - 110Db DNR
 - Supports Rates From 8 kHz to 384 kHz
- HiFi Stereo Audio ADC:
 - 100dB SNR
 - Sample Rates From 8 kHz to 384 kHz
- RoHS compliant

Application

- True wireless stereo earbud solution
- High-end BT speaker
- Smart BT/WIFI music box
- BT docking stations and Soundbars
- BT boom box
- Other portable audio device
- IOT platform

Module picture as below showing



Figure 1: FSC-BT958 Picture

2. General Specification

Table 1: General Specifications

Categories	Features	Implementation
Wireless Specification	Bluetooth Version	Bluetooth v5.0
	Frequency	2.402 - 2.480 GHz
	Transmit Power	+10 dBm (Maximum)
	Receive Sensitivity	-85 dBm@0.1%BER (Typical)
	Modulation	GFSK, $\pi/4$ DQPSK , 8DPSK
Host Interface and Peripherals	UART Interface	TX, RX, CTS, RTS
		Default 115200,N,8,1
		Baudrate support from 1200 to 921600
Profiles	GPIO	5, 6, 7, 8 data bit character
	GPIO	9(maximum – configurable) lines
Maximum Connections	Classic Bluetooth	SPP (Serial Port Profile) - Up to 600 Kbps
	Bluetooth Low Energy	GATT Client & Peripheral - Any Custom Services
Supply Voltage	Classic Bluetooth	1 Clients
	Bluetooth Low Energy	Support
Physical	Supply	VBAT_IN: 3.4V ~ 4.5V
Environmental	Dimensions	13mm(W) X 26.9mm(L) X 2.0H); Pad Pitch 1mm
	Operating	-20°C to +80°C
Miscellaneous	Storage	-30°C to +90°C
	Lead Free	Lead-free and RoHS compliant
Humidity	Warranty	One Year
MSL grade:		10% ~ 90% non-condensing
ESD grade:		MSL 3
		Human Body Model: Class-2
		Machine Model: Class-B

3. HARDWARE SPECIFICATION

3.1 PIN Diagram

			Alternative Function: I2S2 synchronous data output
7,9	GPIO_01/I2S_WS	I/O	Programmable input/output line Alternative Function: I2S2 word select
8	RESET	I	Reset if low. Pull low for minimum 5 ms to cause a reset
13	BT_TX	I/O	UART Data output
14	BT_RX	I/O	UART Data input
15	GPIO_10/BT_CTS	I/O	UART clear to send, active low Alternative Function: Programmable input/output line
16	GPIO_11/BT_RTS	I/O	UART request to send, active low Alternative Function: Programmable input/output line
17	LED0	I/O	LED driver. (RED LED)
18	LED1	I/O	LED driver. (BLUE LED)
19	LED2	I/O	LED driver. (GREEN LED)
20	GPADC1	I/O	Analogue programmable input/output line
21	NC		
22	GND	Vss	Power Ground
23	NC		
24	DEBUG_RX/I2C_CLK	I/O	Debug_RX Alternative Function2: I2C_SCL
25	DEBUG_TX/I2C_DAT	I/O	Debug_TX Alternative Function2: I2C_SDA
26	NC		
27	NC		
28	NC		
29	NC		
30	NC		
31	NC		
32	GND	Vss	Power Ground
33	VBAT_IN	Vdd	Power supply voltage 3.4V~ 4.5V(Battery positive terminal)
34	VREGENABLE	I	Power enable * Chip power on input, high level/ high pules(min 10ms) is active .
35	NC		
36	NC		
37	NC		
38	NC		
39	VCC_CHG	Vdd	Battery charger input (5V)
40	NC		
41	NC		
42	NC		
43	MIC_P	I	Line or Microphone input positive
44	MIC_N	I	Line or Microphone input negative
45	MIC_BIAS	O	Microphone bias
46	SPK_RN	O	Speaker output negative, right
47	SPK_RP	O	Speaker output positive, right

48	SPK_LN	O	Speaker output negative, left
49	SPK_LP	O	Speaker output positive, left
50	GND	Vss	Power Ground
51	EXT_ANT	RF	Bluetooth 50Ω transmitter output /receiver input
52	GND	Vss	Power Ground

4. PHYSICAL INTERFACE

4.1 Power Supply

The transient response of the regulator is important. If the power rails of the module are supplied from an external voltage source, the transient response of any regulator used should be 20μs or less. It is essential that the power rail recovers quickly.

4.2 Audio Interfaces

4.2.1 Microphone Input & line IN

Check the Application Schematic for the microphone input & line IN design.

If need to use Microphone & Line IN simultaneously, please refer to the **Analog Characteristics** introduction.

4.2.2 SPEAKER

Check the Application Schematic for the microphone input & line IN design.

Please refer to the **Analog Characteristics** introduction.

4.3 Reset

The module may be reset from several sources: Power-on Reset (POR), Low level on the nRESET Pin (nRST), Debug Reset, Watchdog time-out reset (WDT), Global soft reset.

4.4 RF Interface

- Fully integrated RF synthesizer without any external component
- TX output power of +10dBm
- High power output(10dBm) Class2 and Class3 transmission supported
- Supports GFSK,π/4 DQPSK and 8DPSK modulation
- High performance in receiver sensitivity, -93dBm@GFSK, -95dBm@π/4 DQPSK, -87dBm@8DPSK

4.5 Serial Interfaces

4.5.1 UART

FSC-BT958 provides one channels of Universal Asynchronous Receiver/Transmitters(UART)(Full-duplex asynchronous communications). The UART Controller performs a serial-to-parallel conversion on data received from the peripheral and a parallel-to-serial conversion on data transmitted from the CPU. Each UART Controller channel supports ten types of interrupts.

This is a standard UART interface for communicating with other serial devices. The UART interface provides a simple mechanism for communicating with other serial devices using the RS232 protocol.

When the module is connected to another digital device, UART_RX and UART_TX transfer data between the two devices.

This module output is at 3.3V CMOS logic levels (tracks VCC). Level conversion must be added to interface with an RS-232 level compliant interface.

Table 3: Possible UART Settings

Parameter	Possible Values
Baudrate	Minimum 1200 baud ($\leq 2\%$ Error)
	Standard 115200bps($\leq 1\%$ Error)
	Maximum 921600bps($\leq 1\%$ Error)
Flow control	Supports Automatic Flow Control (CTS and RTS lines)
Parity	None, Odd or Even
Number of stop bits	1 /1.5/2
Bits per channel	5/6/7/8

When connecting the module to a host, please make sure to follow .

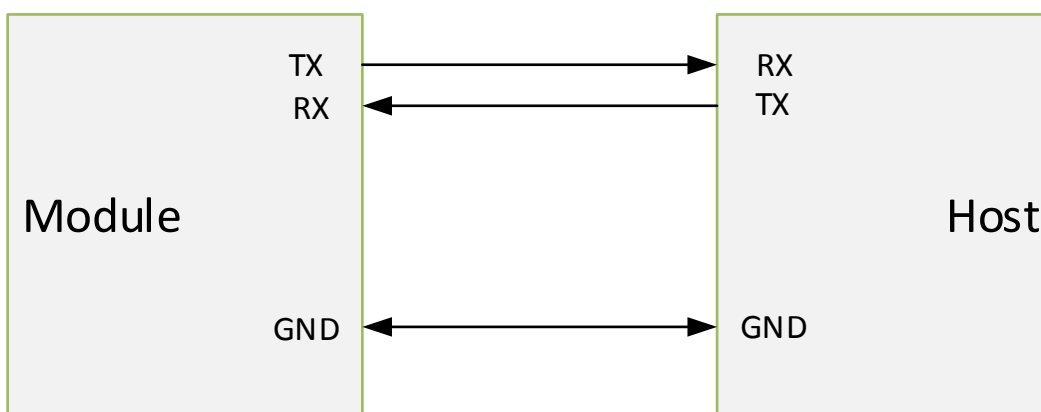

Figure 4: UART Connection

5. ELECTRICAL CHARACTERISTICS

5.1 Absolute Maximum Ratings

Table 4: Absolute Maximum Rating

Parameter	Min	Type	Max	Unit
V _{BAT_IN} Input Voltage	3.4	3.8	4.5	V
V _{IL} CMOS Low Level Input Voltage	0		0.3*1.8	V
V _{IH} CMOS High Level Input Voltage	1.8		0.7*1.8	V

5.2 Recommended Operating Conditions

Table 5: Recommended Operating Conditions

Parameter	Min	Type	Max	Unit
V _{BAT_IN} Input Voltage	3.4	3.8	4.5	V
T _A - Operating Temperature	-20	25	+80	°C
T _{ST} - Storage Temperature	-30	25	+90	°C
I _{IN} Input Current	-10		+10	mA

5.3 Audio Codec Electrical Characteristics

Table 6: Digital to Analogue Converter under 1.95V (b)

Parameter	Condition	Min	Type	Max	Unit	
Resolution				24	Bits	
Output Sample Rete, F _{sample}		8		384	kHz	
SNR	fin=1kHz	Fsample	Load			
	B/W=20Hz~20kHz	48kHz	200kΩ	112	dB	
	A-Weighted	48kHz	32Ω	120	dB	
	1Vrms Output	48kHz	16Ω	120	dB	
THD+N		Fsample	Load			
		8kHz	100kΩ	-100	-95	dB
	fin=1kHz	8kHz	32Ω	-100	-95	dB
	B/W=20Hz~20kHz	8kHz	16Ω	-100	-95	dB
	1Vrms Output	48kHz	100kΩ	-100	-95	dB
		48kHz	32Ω	-100	-95	dB
		48kHz	16Ω	-100	-98	dB
Digital Gain	Digital Gain Resolution = 1dB	-70		24	dB	
Analogue Gain	Analogue Gain Resolution = 0.75dB	-18		3	dB	
Output Voltage	600-Ohm loading			1000	mV rms	
IMD	TMTPE		93			
Freq. Response	0.02-20kHz 30mW output					
Phase	1kHz sine wave					
Pop Up Noise						
Noise Floor	A-WT Noise Gating					

Noise Floor	Aduio PA on A-WT
Crosstalk	100Hz,1Vrms Output
Crosstalk	1KHz,1Vrms Output
Crosstalk	10KHz,1Vrms Output
DNR	A-Weight,32Ω

(a) SNR is the ratio of output level with a 1-kHz full-scale input, to the output level playing an all-zero signal, measured A-weighted over a 20-Hz to 20-kHz bandwidth.

(b) The BES2300-L provides a digital noise gate function for each of the output signal paths. The noise gate ensures best noise performance when the signal path is idle. When the noise gate is enabled, and the applicable signal level is below the noise gate threshold, then the noise gate is activated, causing the signal path to be muted.

Table 7: Codec - Analogue to Digital Converter under 1.95V

Parameter	Condition	Min	Type	Max	Unit
Resolution				24	Bits
Output Sample Rete, Fsample		8		384	kHz
SNR	fin=1kHz	Fsample			
	B/W=20Hz~20kHz A-Weighted 0.7Vrms Input	48kHz	100		dB
THD+N	fin=1kHz	Fsample			
	B/W=20Hz~20KHz 1Vrms Output	48kHz	-95		dB
Digital Gain	Digital Gain Resolution = 1dB	-30		30	dB
Analogue Gain	Analogue Gain Resolution = 3dB	-9		12	dB

6. MSL & ESD

Table 8: MSL and ESD

Parameter	Value
MSL grade:	MSL 3
ESD grade:	Human Body Model: Class-2
	Machine Model: Class-B

7. RECOMMENDED TEMPERATURE REFLOW PROFILE

Prior to any reflow, it is important to ensure the modules were packaged to prevent moisture absorption. New packages contain desiccate (to absorb moisture) and a humidity indicator card to display the level maintained during storage and shipment. If directed to bake units on the card, please check the below **next table** and follow instructions specified by IPC/JEDEC J-STD-033.

Note: The shipping tray cannot be heated above 65°C. If baking is required at the higher temperatures displayed in the below **next table**, the modules must be removed from the shipping tray.

Any modules not manufactured before exceeding their floor life should be re-packaged with fresh desiccate and a new humidity indicator card. Floor life for MSL (Moisture Sensitivity Level) 3 devices is 168 hours in ambient environment

30°C/60%RH.

Table 9: Recommended baking times and temperatures

MSL	125°C Baking Temp.		90°C/≤ 5%RH Baking Temp.		40°C/ ≤ 5%RH Baking Temp.	
	Saturated @	Floor Life Limit	Saturated @	Floor Life Limit	Saturated @	Floor Life Limit
	30°C/85%	+ 72 hours @ 30°C/60%	30°C/85%	+ 72 hours @ 30°C/60%	30°C/85%	+ 72 hours @ 30°C/60%
3	9 hours	7 hours	33 hours	23 hours	13 days	9 days

Feasycom surface mount modules are designed to be easily manufactured, including reflow soldering to a PCB. Ultimately it is the responsibility of the customer to choose the appropriate solder paste and to ensure oven temperatures during reflow meet the requirements of the solder paste. Feasycom surface mount modules conform to J-STD-020D1 standards for reflow temperatures.

The soldering profile depends on various parameters necessitating a set up for each application. The data here is given only for guidance on solder reflow.

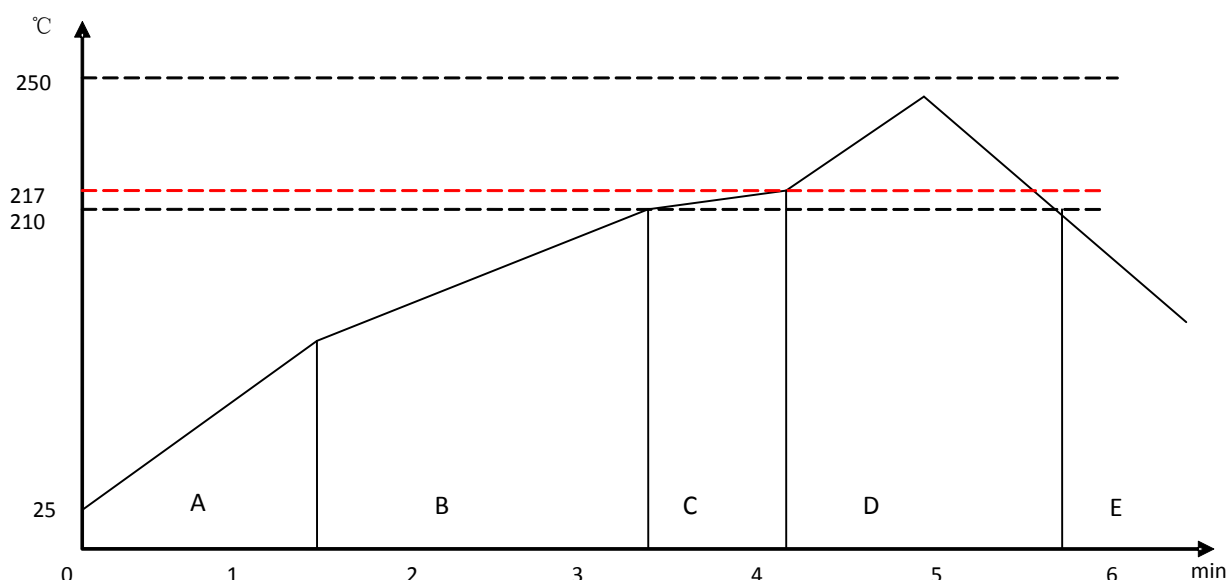
**Figure 5:** Typical Lead-free Re-flow

Pre-heat zone (A) — This zone raises the temperature at a controlled rate, **typically 0.5 – 2 °C/s**. The purpose of this zone is to preheat the PCB board and components to 120 ~ 150 °C. This stage is required to distribute the heat uniformly to the PCB board and completely remove solvent to reduce the heat shock to components.

Equilibrium Zone 1 (B) — In this stage the flux becomes soft and uniformly encapsulates solder particles and spread over PCB board, preventing them from being re-oxidized. Also with elevation of temperature and liquefaction of flux, each activator and rosin get activated and start eliminating oxide film formed on the surface of each solder particle and PCB board. **The temperature is recommended to be 150° to 210° for 60 to 120 second for this zone.**

Equilibrium Zone 2 (C) (optional) — In order to resolve the upright component issue, it is recommended to keep the temperature in 210 – 217 ° for about 20 to 30 second.

Reflow Zone (D) — The profile in the figure is designed for Sn/Ag3.0/Cu0.5. It can be a reference for other lead-free solder. The peak temperature should be high enough to achieve good wetting but not so high as to cause component discoloration or damage. Excessive soldering time can lead to intermetallic growth which can result in a brittle joint. The recommended peak temperature (Tp) is 230 ~ 250 °C. The soldering time should be 30 to 90 second when the temperature is above 217 °C.

Cooling Zone (E) — The cooling rate should be fast, to keep the solder grains small which will give a longer-lasting joint. **Typical cooling rate should be 4 °C.**

8. MECHANICAL DETAILS

8.1 Mechanical Details

- Dimension: 13mm(W) x 26.9mm(L) x 2.0mm(H) Tolerance: $\pm 0.1\text{mm}$
- Module size: 13mm X 26.9mm Tolerance: $\pm 0.2\text{mm}$
- Pad size: 1.6mmX0.6mm Tolerance: $\pm 0.2\text{mm}$
- Pad pitch: 1.0mm Tolerance: $\pm 0.1\text{mm}$

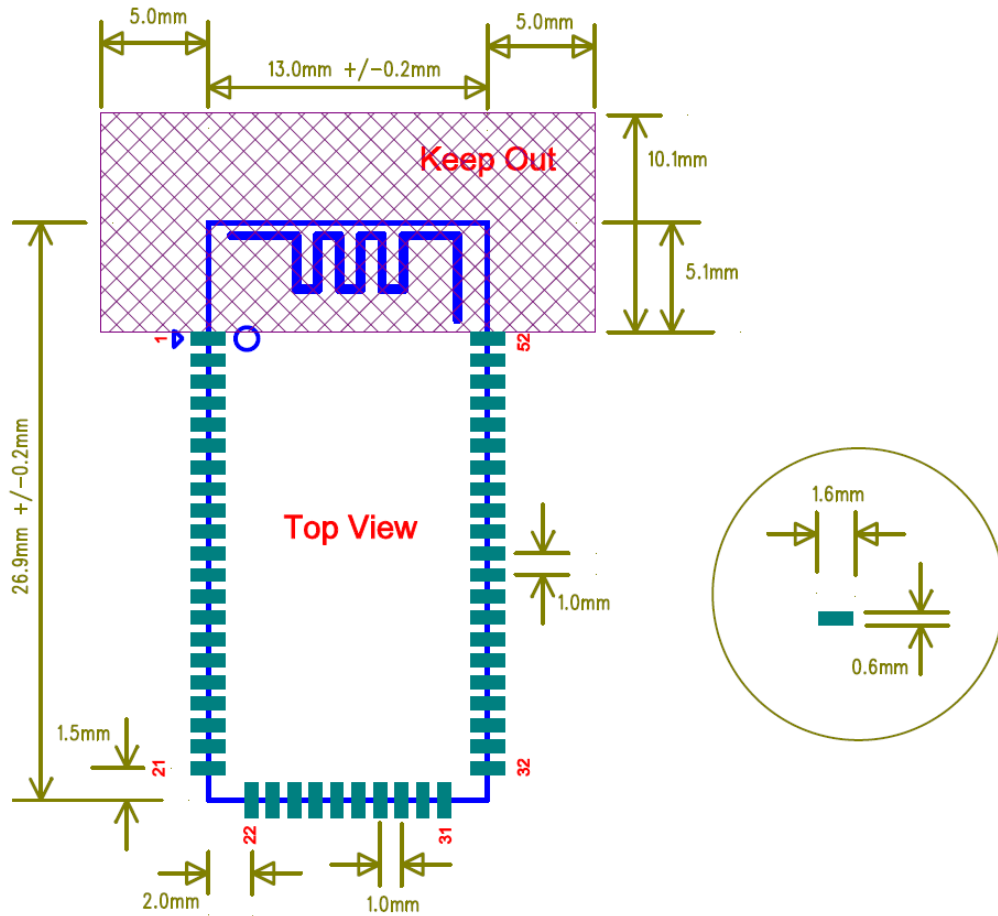

Figure 6: FSC-BT958 footprint

9. HARDWARE INTEGRATION SUGGESTIONS

9.1 Soldering Recommendations

FSC-BT1006A is compatible with industrial standard reflow profile for Pb-free solders. The reflow profile used is dependent on the thermal mass of the entire populated PCB, heat transfer efficiency of the oven and particular type of solder paste used. Consult the datasheet of particular solder paste for profile configurations.

Feasycom will give following recommendations for soldering the module to ensure reliable solder joint and operation of the module after soldering. Since the profile used is process and layout dependent, the optimum profile should be studied case by case. Thus following recommendation should be taken as a starting point guide.

9.2 Layout Guidelines(Internal Antenna)

It is strongly recommended to use good layout practices to ensure proper operation of the module. Placing copper or any metal near antenna deteriorates its operation by having effect on the matching properties. Metal shield around the antenna will prevent the radiation and thus metal case should not be used with the module. Use grounding vias separated max 3 mm apart at the edge of grounding areas to prevent RF penetrating inside the PCB and causing an unintentional resonator. Use GND vias all around the PCB edges.

The mother board should have no bare conductors or vias in this restricted area, because it is not covered by stop mask print. Also no copper (planes, traces or vias) are allowed in this area, because of mismatching the on-board antenna.

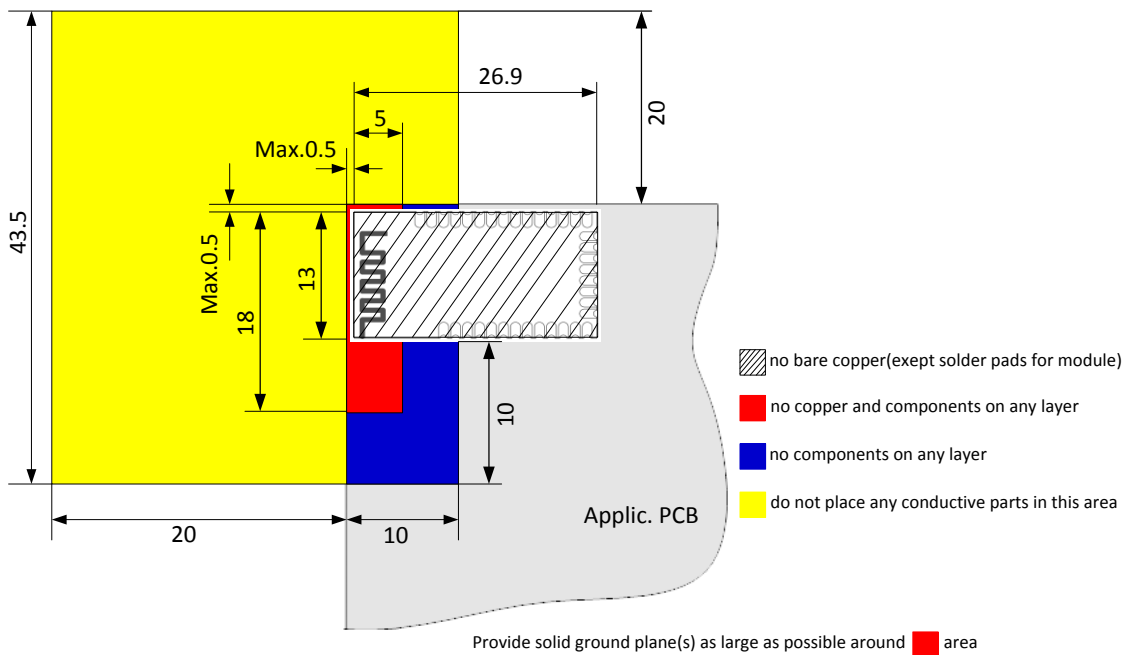

Figure 7: FSC-BT1006A Restricted Area

Following recommendations helps to avoid EMC problems arising in the design. Note that each design is unique and the following list do not consider all basic design rules such as avoiding capacitive coupling between signal lines. Following list is aimed to avoid EMC problems caused by RF part of the module. Use good consideration to avoid problems arising from digital signals in the design.

Ensure that signal lines have return paths as short as possible. For example if a signal goes to an inner layer through a via, always use ground vias around it. Locate them tightly and symmetrically around the signal vias. Routing of any sensitive signals should be done in the inner layers of the PCB. Sensitive traces should have a ground area above and under the line. If this is not possible, make sure that the return path is short by other means (for example using a ground line next to the signal line).

9.3 Layout Guidelines(External Antenna)

Placement and PCB layout are critical to optimize the performances of a module without on-board antenna designs. The trace from the antenna port of the module to an external antenna should be 50Ω and must be as short as possible to avoid any interference into the transceiver of the module. The location of the external antenna and RF-IN port of the module should be kept away from any noise sources and digital traces. A matching network might be needed in between the external antenna and RF-IN port to better match the impedance to minimize the return loss.

As indicated in **Figure** below, RF critical circuits of the module should be clearly separated from any digital circuits on the system board. All RF circuits in the module are close to the antenna port. The module, then, should be placed in this way that module digital part towards your digital section of the system PCB.

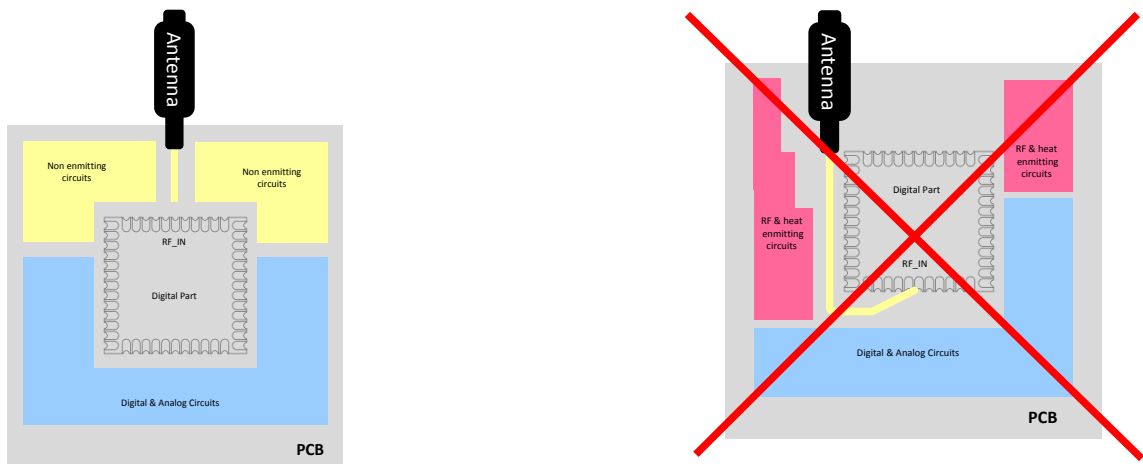

Figure 8: Placement the Module on a System Board

9.3.1 Antenna Connection and Grounding Plane Design

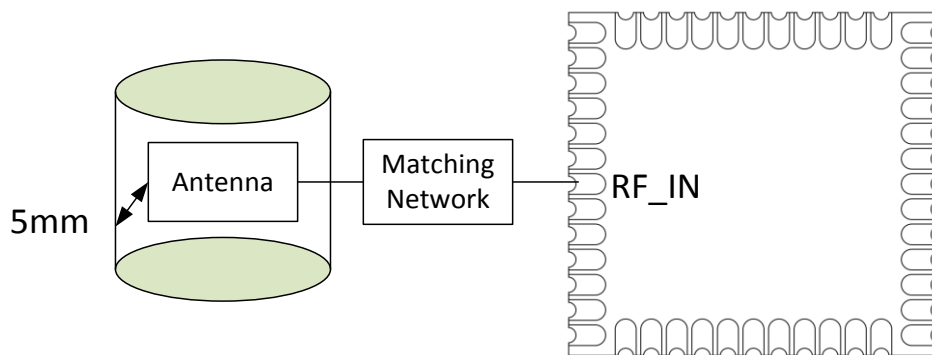

Figure 9: Leave 5mm Clearance Space from the Antenna

General design recommendations are:

- The length of the trace or connection line should be kept as short as possible.
- Distance between connection and ground area on the top layer should at least be as large as the dielectric thickness.
- Routing the RF close to digital sections of the system board should be avoided.

- To reduce signal reflections, sharp angles in the routing of the micro strip line should be avoided. Chamfers or fillets are preferred for rectangular routing; 45-degree routing is preferred over Manhattan style 90-degree routing.

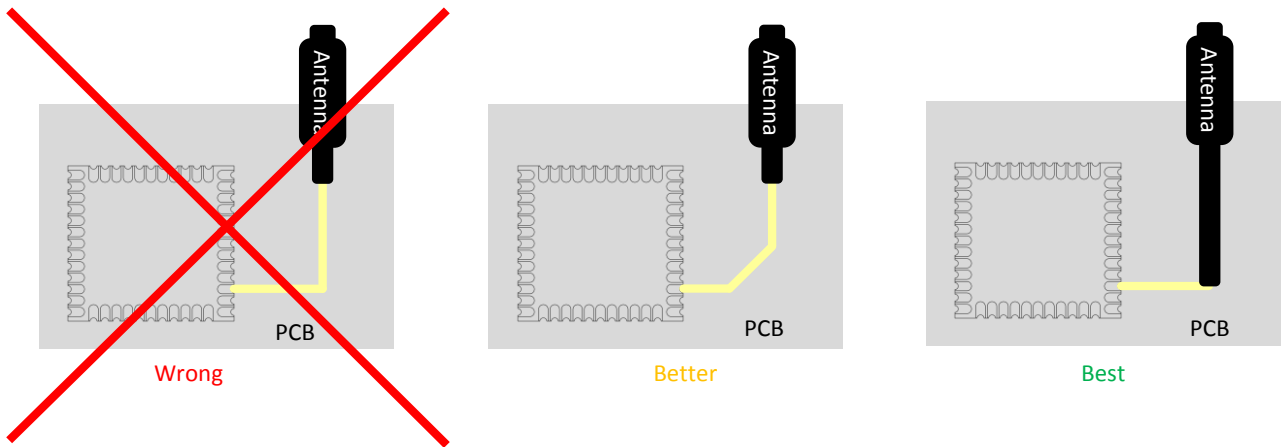

Figure 10: Recommended Trace Connects Antenna and the Module

- Routing of the RF-connection underneath the module should be avoided. The distance of the micro strip line to the ground plane on the bottom side of the receiver is very small and has huge tolerances. Therefore, the impedance of this part of the trace cannot be controlled.
- Use as many vias as possible to connect the ground planes.

10. PRODUCT PACKAGING INFORMATION

10.1 Default Packing

- a, Tray vacuum
- b, Tray Dimension: 180mm * 195mm





Figure 11: Tray vacuum

10.2 Packing box(Optional)

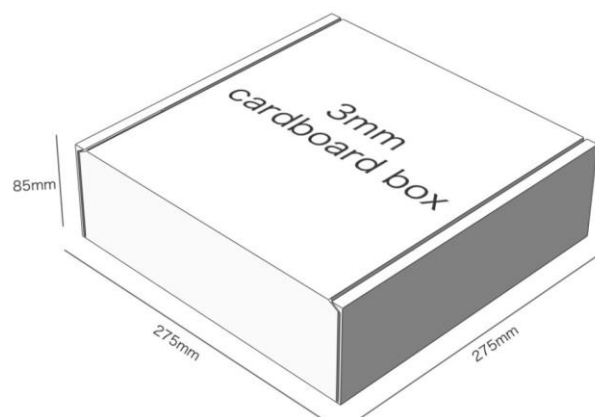

* If require any other packing, must be confirmed with customer

* Package: 1000PCS Per Carton (Min Carton Package)

Figure 12: Packing Box

11. APPLICATION SCHEMATIC

Integration instructions for host product manufacturers according to KDB 996369 D03 OEM Manual v01

2.2 List of applicable FCC rules

FCC Part 15.247

2.3 Specific operational use conditions

This transmitter/module and its antenna(s) must not be co-located or operating in conjunction with any transmitter. This information also extends to the host manufacturer's instruction manual.

2.4 Limited module procedures

not applicable

2.5 Trace antenna designs

not applicable

2.6 RF exposure considerations

This equipment complies with FCC RF radiation exposure limits set forth for an uncontrolled environment. This compliance to FCC radiation exposure limits for an uncontrolled environment, and minimum of 5mm separation between antenna and body.

The host product manufacturer would provide the above information to end users in their end-product manuals.

2.7 Antennas

PCB antenna; 2dBi; 2.402 GHz~2.480GHz

2.8 Label and compliance information

The end product must carry a physical label or shall use e-labeling followed KDB784748D01 and KDB 784748 stating "Contains Transmitter Module FCC ID: 2AMWOFSC-BT958".

2.9 Information on test modes and additional testing requirements

For more information on testing, please contact the manufacturer.

2.10 Additional testing, Part 15 Subpart B disclaimer

The modular transmitter is only FCC authorized for the specific rule parts (FCC Part 15.247) listed on the grant, and that the host product manufacturer is responsible for compliance to any other FCC rules that apply to the host not covered by the modular transmitter grant of certification. The final host product still requires Part 15 Subpart B compliance testing with the modular transmitter installed when contains digital circuitry.

FCC Statements

(OEM) Integrator has to assure compliance of the entire end-product incl. the integrated RF Module. For 15 B (§15.107 and if applicable §15.109) compliance, the host manufacturer is required to show compliance with 15 while the module is installed and operating.

Furthermore the module should be transmitting and the evaluation should confirm that the module's intentional emissions (15C) are compliant (fundamental / out-of-band). Finally the integrator has to apply the appropriate equipment authorization (e.g. Verification) for the new host device per definition in §15.101.

Integrator is reminded to assure that these installation instructions will not be made available to the end-user of the final host device.

The final host device, into which this RF Module is integrated" has to be labeled with an auxiliary label stating the FCC ID of the RF Module, such as "Contains FCC ID: 2AMWOFSC-BT958

"This device complies with part 15 of the FCC rules. Operation is subject to the following two conditions:

- (1) this device may not cause harmful interference, and
- (2) this device must accept any interference received, including interference that may cause undesired operation."

"Changes or modifications to this unit not expressly approved by the party responsible for compliance could void the user's authority to operate the equipment."

the Integrator will be responsible to satisfy SAR/ RF Exposure requirements, when the module integrated into the host device.

Module statement

The single-modular transmitter is a self-contained, physically delineated, component for which compliance can be demonstrated independent of the host operating conditions, and which complies with all eight requirements of § 15.212(a)(1) as summarized below.

- 1) The radio elements have the radio frequency circuitry shielded.
- 2) The module has buffered modulation/data inputs to ensure that the device will comply with Part 15 requirements with any type of input signal.
- 3) The module contains power supply regulation on the module.
- 4) The module contains a permanently attached antenna.
- 5) The module demonstrates compliance in a stand-alone configuration.
- 6) The module is labeled with its permanently affixed FCC ID label.
- 7) The module complies with all specific rules applicable to the transmitter, including all the conditions provided in the integration instructions by the grantee.
- 8) The module complies with RF exposure requirements.

NOTE: This equipment has been tested and found to comply with the limits for a Class B digital device, pursuant to part 15 of the FCC Rules. These limits are designed to provide reasonable protection against harmful interference in a residential installation. This equipment generates uses and can radiate radio frequency energy and, if not installed and used in accordance with the instructions, may cause harmful interference to radio communications. However, there is no guarantee that interference will not occur in a particular installation. If this equipment does cause harmful interference to radio or television reception, which can be determined by turning the equipment off and on, the user is encouraged to try to correct the interference by one or more of the following measures:

- Reorient or relocate the receiving antenna.
- Increase the separation between the equipment and receiver.
- Connect the equipment into an outlet on a circuit different from that to which the receiver is connected.
- Consult the dealer or an experienced radio/TV technician for help