



# FSC-BT1026

Bluetooth Module Datasheet

Version 1.3

# 1. INTRODUCTION

## Overview

FSC-BT1026x is a Bluetooth dual-mode module series. It supports a Bluetooth Low Energy and compliant system for audio and data communication.

FSC-BT1026x integrates an ultra-low-power DSP and application processor with embedded flash memory, a high-performance stereo codec, a power management subsystem, I<sup>2</sup>S, LED drivers and ADC I/O in a SOC IC.

Both cores use external flash to execute code, making it easy for user to differentiate products from new features without delaying the development

By default, FSC-BT1026x module is equipped with powerful and easy-to-use Feasycom firmware. It's easy to use and completely encapsulated. Feasycom firmware enables users to access Bluetooth functionality with simple ASCII commands delivered to the module over serial interface - it's just like a Bluetooth modem.

Therefore, FSC-BT1026x provides an ideal solution for developers who want to integrate Bluetooth wireless technology into their design.

## Features

- Qualified to Bluetooth® v5.1 specification
- 32 MHz Developer Processor for applications
- Firmware Processor for system
- Advanced audio algorithms
- High-performance 24-bit stereo audio interface
- Digital and analog microphone interfaces
- I<sup>2</sup>S/PCM, SPDIF interfaces input/output
- aptX, aptX HD, aptX Low Latency
- SBC and AAC audio codecs support
- Serial interfaces: UART, Bit Serializer (I<sup>2</sup>C/SPI), USB 2.0
- Integrated PMU: Dual SMPS for system/digital circuits, Integrated Li-ion battery charger

## Application subsystem

- Dual core application subsystem 32 MHz operation
- 32-bit Firmware Processor:
  - Reserved for system use
  - Runs Bluetooth upper stack, profiles, house-keeping code
- 32-bit Developer Processor:
  - Runs developer applications
- Both cores execute code from external flash memory using QSPI clocked at 32MHz
- On-chip caches per core allow for optimized performance and power consumption

## Bluetooth subsystem

- Qualified to Bluetooth v5.1 specification including 2 Mbps Bluetooth low energy(Production parts)
- Single ended antenna connection with on-chip balun and Tx/Rx switch
- Bluetooth, Bluetooth low energy, and mixed topologies supported
- Class 1 support

## Application

- Bluetooth speakers
- Bluetooth music box
- Wired/wireless stereo headsets/headphones
- USB audio/USB to Bluetooth dongle



Figure 1: FSC-BT1026 picture

## 2. General Specification

**Table 1:** General Specifications

Categories	Features	Implementation
Wireless Specification	Chip	QCC30XX
	Bluetooth Version	V5.1 Dual-mode
	Frequency	2.402 - 2.480 GHz
	Transmit Power	+6.221 dBm (Maximum)
	Receive Sensitivity	-96.0 dBm (typ.) $\pi/4$ DQPSK receiver sensitivity -89.0 dBm (typ.) 8DPSK receiver sensitivity -100 dBm (typ.) BLE 1 Ms/s receiver sensitivity Real-time digitised RSSI available to application
	Raw Data Rates (Air)	3 Mbps (Classic BT - BR/EDR)
Host Interface and Peripherals	UART Interface	TX, RX, CTS, RTS
		General Purpose I/O
		Default 115200,N,8,1
		Baudrate support from 1200 to 4000000
	GPIO	20 (maximum – configurable) lines
		O/P drive strength (2, 4, 8, or 12 mA)
		Pull-up resistor (33 K $\Omega$ ) control
	I <sup>2</sup> C Interface	1 I <sup>2</sup> C Master interface with speed up to 400 kbps
	SPI Interface	SPI debug and programming interface with read access disable locking
	ADC Interface	Analog input voltage range: 0~ 1.854V
		10-bit ADC
	USB Interface	1 channels (configured from GPIO total)
		1 full-speed (12Mbps)
		aptX, aptX HD, aptX Low Latency, SBC and AAC audio codecs
		Configurable Signal Detection to trigger events
1 bank of up to 10-stage Speaker Parametric EQ		
6 banks of up to 5-stage User Parametric EQ for music enhancement		
Compannder to compress or expand the dynamic range of the audio		
Post Mastering to improve DAC fidelity		
I <sup>2</sup> S/PCM outputs with crossover		
USB audio		
Audio CODEC	Stereo audio ADC with line input, stereo audio DAC	
	Supported sample rates of 8, 16, 32, 44.1, 48 and 96 kHz,192kHz(Input)	
	MIC SNR: 92 dB	
	MIC THD+N: 0.004%	
	Audio Output SNR: 100dBA typ	
	Audio Output THD+N: -90.5 typ	

		Audio Output Power: 1000mV (max) (0dBFS 10K load)
		Stereo separation (crosstalk): -80dB(Min)
Profiles	BR/EDR	SPP (Serial Port Profile) - Up to 600 Kbps A2DP/AVRCP/HFP/HSP/HOGP/PBAP/SPP Profiles support
	Bluetooth Low Energy	GATT Client & Peripheral Simultaneous BR/EDR and BLE support
Maximum Connections	BR/EDR	up to 7 active slaves
	Bluetooth Low Energy	1 connection as peripheral , up to 5 connections as central
FW upgrade		Via UART(TBD)
		USB(TBD)
		OTA
		SPI
Supply Voltage	Supply	VDD_IO: 1.7 ~ 3.3V; VBAT_IN: 2.8V~ 4.3V
Power Consumption		Max Peak Current(TX Power @ +8dBm TX): 78mA
		Standby Doze (Wait event) - 15mA (TBD)
		Deep Sleep - <1mA(TBD)
Physical	Dimensions	13mm(W) X 26.9mm(L) X 2.2mm(H); Pad Pitch 1mm
Environmental	Operating	-40°C to +85°C
	Storage	-40°C to +85°C
Miscellaneous	Lead Free	Lead-free and RoHS compliant
	Warranty	One Year
Humidity		10% ~ 90% non-condensing
MSL grade:		MSL 3
ESD grade:		Human Body Model: Class 2 2kV (all pins)
		Charged Device Model: Class III 500 V (all pins)

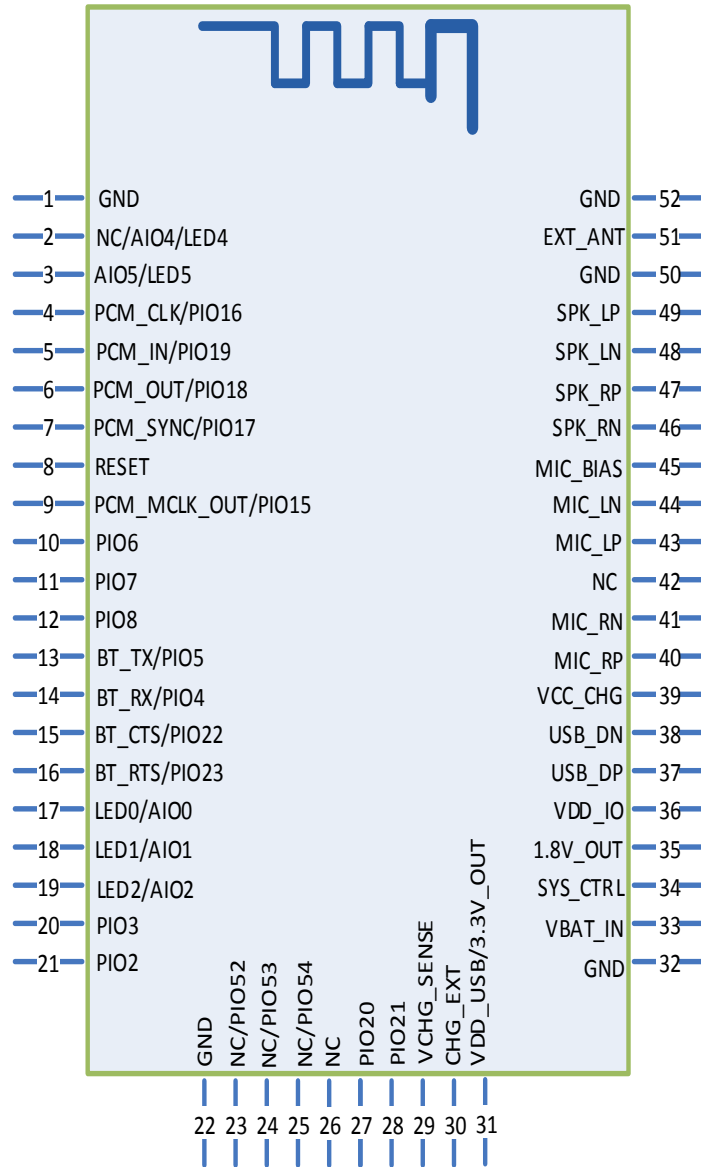

Figure 2: FSC-BT1026x PIN Diagram(Top View)

### 3.0 PIN Definition Descriptions

Table 2: Pin definition

Pin	Pin Name	Type	Pin Descriptions	Notes
1	GND	Vss	Power Ground	
2	NC/AIO4/LED4	A,I/O	NC General-purpose analog/digital input or open drain LED output.	
3	AIO5/LED5	A,I/O	General-purpose analog/digital input or open drain LED output.	Note 8
4	PCM_CLK/PIO16	I/O	Programmable I/O line 16. Alternative function: PCM_CLK	Note 6

5	PCM_IN/PIO19	I/O	Programmable I/O line 19. Alternative function: PCM_DIN[0]	Note 6
6	PCM_OUT/PIO18	I/O	Programmable I/O line 18. Alternative function: PCM_DOUT[0]	Note 6
7	PCM_SYNC/PIO17	I/O	Programmable I/O line 17. Alternative function: PCM_SYNC	Note 6
8	RESET	I/O	Automatically defaults to RESET# mode when the device is unpowered, or in off modes. Reconfigurable as a PIO after boot.	
9	PCM_MCLK_OUT/PIO15	I/O	Programmable I/O line 15. Alternative function: MCLK_OUT	
10	PIO6	I/O	Programmable I/O line 6. Alternative function: TBR_MOSI[0]	
11	PIO7	I/O	Programmable I/O line 7. Alternative function: TBR_MISO[0]	
12	PIO8	I/O	Programmable I/O line 8. Alternative function: TBR_CLK	
13	BT_TX/PIO5	I/O	BT_TX /Programmable I/O line 5. Alternative function: TBR_MISO[1]	Note 6
14	BT_RX/PIO4	I/O	BT_RX/Programmable I/O line 4. Alternative function: TBR_MOSI[1]	Note 6
15	BT_CTS/PIO22 PIO3	I/O I/O	BT_CTS/Programmable I/O line 22 BT_CTS/Programmable I/O line 3	Note 6
16	BT_RTS/PIO23 PIO2	I/O I/O	BT_RTS/Programmable I/O line 23 BT_RTS/Programmable I/O line 2	Note 6
17	AIO0/LED0	A,I/O	General-purpose analog/digital input or open drain LED output.	Note 6,8
18	AIO1/LED1	A,I/O	General-purpose analog/digital input or open drain LED output.	Note 6,8
19	AIO2/LED2	A,I/O	General-purpose analog/digital input or open drain LED output.	Note 6,8
20	PIO3 PIO60	I/O	Programmable I/O line 3 Programmable I/O line 60	
21	PIO2 PIO61	I/O	Programmable I/O line 2 Programmable I/O line 61	
22	GND	Vss	Power Ground	
23	NC/PIO52	I/O	NC (For FSC-BT1026AB) Programmable I/O line 52	
24	NC/PIO53	I/O	NC (For FSC-BT1026AB) Programmable I/O line 53	
25	NC/PIO54	I/O	NC (For FSC-BT1026AB) Programmable I/O line 54	
26	NC			

27	PIO20	I/O	Programmable I/O line 20. Alternative function: PCM_DOUT[1]	Note 5
28	PIO21	I/O	Programmable I/O line 21. Alternative function: PCM_DOUT[2]	Note 5
29	VCHG_SENSE		Charger input sense pin after external mode sense-resistor. High impedance. NOTE: If using internal charger or no charger, connect VCHG_SENSE direct to VCHG.	
30	CHG_EXT		External charger transistor current control. Connect to base of external charger transistor as per application schematic.	
31	VDD_USB/3.3V_OUT		3.3V voltage output (MAX. 50mA OUT)	Note 7
32	GND	Vss	Power Ground	
33	VBAT_IN	Vdd	Battery voltage input.	
34	SYS_CTRL	I	Typically connected to an ON/OFF push button. Boots device in response to a button press when power is still present from battery and/or charger but software has placed the device in the OFF or DORMANT state. Additionally useable as a digital input in normal operation. No pull.	Note 3
35	1.8V_OUT	Vdd	1.8V voltage output	Note 1
36	VDD_IO	I	PIO supply(1.8 V~3.3V)	Note 2
37	USB_DP		USB Full Speed device D+ I/O. IEC-61000-4-2 (device level) ESD Protection	Note 4
38	USB_DN		USB Full Speed device D- I/O. IEC-61000-4-2 (device level) ESD Protection	Note 4
39	VCC_CHG	Vdd	Charger input to Bypass regulator.	Note 4
40	MIC_RP	A	Microphone differential 2 input, positive. Alternative function: Differential audio line input right, positive	
41	MIC_RN	A	Microphone differential 2 input, negative. Alternative function: Differential audio line input right, negative	
42	NC			
43	MIC_LP	A	Microphone differential 1 input, positive. Alternative function: Differential audio line input left, positive	
44	MIC_LN	A	Microphone differential 1 input, negative. Alternative function: Differential audio line input left, negative	
45	MIC_BIAS	Vdd	Mic bias output.	
46	AUDIO_HPR_N/ SPK_RN	A	Headphone/speaker differential right output, negative. Alternative function: Differential right line output, negative	
47	AUDIO_HPR_P/ SPK_RP	A	Headphone/speaker differential right output, positive.	

			Alternative function: Differential right line output, positive	
48	AUDIO_HPL_N/ SPK_LN	A	Headphone/speaker differential left output, negative. Alternative function: Differential left line output, negative	
49	AUDIO_HPL_P/ SPK_LP	A	Headphone/speaker differential left output, positive. Alternative function: Differential left line output, positive	
50	GND	Vss	Power Ground	
51	RF_OUT	RF	Bluetooth transmit/receive.	Note 9
52	GND	Vss	Power Ground	

**Module Pin Notes:**

Note 1	The internal output of 1.8 V power supply provides maximum 30mA current, and the specific use method can see the application circuit diagram
Note 2	Provid voltage reference to I/O, such as: PIO, UART, SPI, I <sup>2</sup> S, PCM,etc
Note 3	Regulator enable input. Can also be sensed as an input. Regulator enable and multifunction button. A high input (tolerant to VBAT) enables the on-chip regulators, which can then be latched on internally and the button used as a multifunction input. <b>* Reset this pin for at least 100ms after VBAT_IN and VDD_IO is up, then set this pin for more than 100 ms (can use MCU/button/delayed circuit to achieve this) to start the system.</b>
Note 4	Using USB function and Lithium battery charging function, the pin should connect 5V voltage
Note 5	1, Alternate I <sup>2</sup> C function 2, I <sup>2</sup> C Serial Clock and Data. It is essential to remember that pull-up resistors on both SCL and SDA lines are not provided in the module and MUST be provided external to the module.
Note 6	For customized module, this pin can be work as I/O Interface.
Note 7	1, When the Pin33(BAT_IN) with a 3V3~4V2 this pin outputs 2V8 ~ 3V0 (maximum current: 50mA) 2, when the No. 39 PIN (VCC_CHG) with a 5V input pin, this pin outputs 3.2V ~ 3.4V (maximum current: 50mA)
Note 8	Analog input voltage range: 0~ 1.8V
Note 9	By default, this PIN is an empty feet. This PIN can connect to an external antenna to improve the Bluetooth signal coverage. To use an external antenna, the position of an 0Ω resistor needs to be changed to disconnect the on-board antenna and connect to the external antenna; Or contact Feasycom for modification.



## 4. MECHANICAL DETAILS

### 4.1 Mechanical Details

- Dimension: 13mm(W) x 26.9mm(L) x 2.2mm(H) Tolerance:  $\pm 0.1\text{mm}$
- Module size: 13mm X 26.9mm Tolerance:  $\pm 0.2\text{mm}$
- Pad size: 1.6mmX0.6mm Tolerance:  $\pm 0.2\text{mm}$
- Pad pitch: 1.0mm Tolerance:  $\pm 0.1\text{mm}$

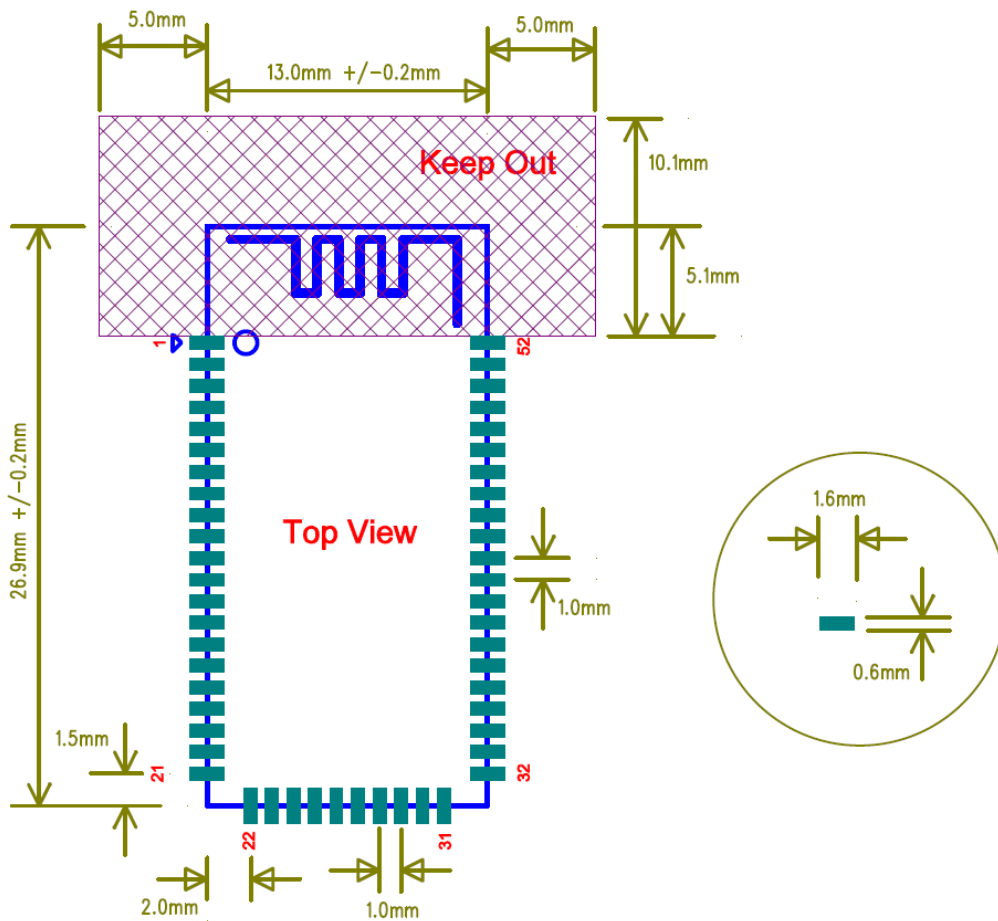

Figure 3: FSC-BT1026 footprint

## FCC Warning

Integration instructions for host product manufacturers according to KDB 996369 D03 OEM Manual v01

## 2.2 List of applicable FCC rules

FCC Part 15.247

## 2.3 Specific operational use conditions

This transmitter/module and its antenna(s) must not be co-located or operating in conjunction with any transmitter. This information also extends to the host manufacturer's instruction manual.

## 2.4 Limited module procedures

Not applicable

## 2.5 Trace antenna designs

It is "not applicable" as trace antenna which is not used on the module.

## 2.7 Antennas

2.4GHZ PCB antenna; 2dBi; 2.400 GHz~2.500GHz

## 2.8 Label and compliance information

The end product must carry a physical label or shall use e-labeling followed KDB784748D01 and KDB 784748 stating "Contains Transmitter Module FCC ID: 2AMWO-FSCBT1026".

## 2.9 Information on test modes and additional testing requirements

For more information on testing, please contact the manufacturer.

## 2.10 Additional testing, Part 15 Subpart B disclaimer

The modular transmitter is only FCC authorized for the specific rule parts (FCC Part 15.247) listed on the grant, and that the host product manufacturer is responsible for compliance to any other FCC rules that apply to the host not covered by the modular transmitter grant of certification. The final host product still requires Part 15 Subpart B compliance testing with the modular transmitter installed when contains digital circuitry.

### FCC Statements

(OEM) Integrator has to assure compliance of the entire end-product incl. the integrated RF Module. For 15 B (§15.107 and if applicable §15.109) compliance, the host manufacturer is required to show compliance with 15 while the module is installed and operating.

Furthermore the module should be transmitting and the evaluation should confirm that the module's intentional emissions (15C) are compliant (fundamental / out-of-band). Finally the integrator has to apply the appropriate equipment authorization (e.g. Verification) for the new host device per definition in §15.101.

Integrator is reminded to assure that these installation instructions will not be made available to the end-user of the final host device.

The final host device, into which this RF Module is integrated" has to be labeled with an auxiliary label stating the FCC ID of the RF Module, such as "Contains FCC ID: FCC ID: 2AMWO-FSCBT1026

"This device complies with part 15 of the FCC rules. Operation is subject to the following two conditions:

- (1) this device may not cause harmful interference, and
- (2) this device must accept any interference received, including interference that may cause undesired operation."

"Changes or modifications to this unit not expressly approved by the party responsible for compliance could void the user's authority to operate the equipment."

The Integrator will be responsible to satisfy SAR/ RF Exposure requirements, when the module integrated into the host device.

#### Module statement

The single-modular transmitter is a self-contained, physically delineated, component for which compliance can be demonstrated independent of the host operating conditions, and which complies with all eight requirements of § 15.212(a)(1) as summarized below.

- 1) The radio elements have the radio frequency circuitry shielded.
- 2) The module has buffered modulation/data inputs to ensure that the device will comply with Part 15 requirements with any type of input signal.
- 3) The module contains power supply regulation on the module.
- 4) The module contains a permanently attached antenna.
- 5) The module demonstrates compliance in a stand-alone configuration.
- 6) The module is labeled with its permanently affixed FCC ID label.
- 7) The module complies with all specific rules applicable to the transmitter, including all the conditions provided in the integration instructions by the grantee.
- 8) The module complies with RF exposure requirements.

NOTE: This equipment has been tested and found to comply with the limits for a Class B digital device, pursuant to part 15 of the FCC Rules. These limits are designed to provide reasonable protection against harmful interference in a residential installation. This equipment generates uses and can radiate radio frequency energy and, if not installed and used in accordance with the instructions, may cause harmful interference to radio communications. However, there is no guarantee that interference will not occur in a particular installation. If this equipment does cause harmful interference to radio or television reception, which can be determined by turning the equipment off and on, the user is encouraged to try to correct the interference by one or more of the following measures:

- Reorient or relocate the receiving antenna.
- Increase the separation between the equipment and receiver.

- Connect the equipment into an outlet on a circuit different from that to which the receiver is connected.
- Consult the dealer or an experienced radio/TV technician for help

## IC Statements

The final host device, into which this RF Module is integrated" has to be labeled with an auxiliary label stating the IC of the RF Module, such as" Contains transmitter module IC: 23872-FSCBT1026 Le périphérique hôte final, dans lequel ce module RF est intégré "doit être étiqueté avec une étiquette auxiliaire indiquant le CI du module RF, tel que" Contient le module émetteur IC: 23872-FSCBT1026

This device contains licence-exempt transmitter(s)/receiver(s) that comply with Innovation, Science and Economic Development Canada's licence-exempt RSS(s). Operation is subject to the following two conditions:

- (1) This device may not cause interference.
- (2) This device must accept any interference, including interference that may cause undesired operation of the device.

L'émetteur/récepteur exempt de licence contenu dans le présent appareil est conforme aux CNR d'Innovation, Sciences et Développement économique Canada applicables aux appareils radio exempts de licence. L'exploitation est autorisée aux deux conditions suivantes :

- (1) L' appareil ne doit pas produire de brouillage;
- (2) L' appareil doit accepter tout brouillage radioélectrique subi, même si le brouillage est susceptible d'en compromettre le fonctionnement.

## Radio Frequency Exposure Statement for IC

The device has been evaluated to meet general RF exposure requirements. The device can be used in mobile exposure conditions. The min separation distance is 15mm.

## Déclaration d'exposition aux radiofréquences pour IC

L'appareil a été évalué pour répondre aux exigences générales en matière d'exposition aux RF. L'appareil peut être utilisé dans des conditions d'exposition mobiles. La distance de séparation minimale est de 15 mm.