



Test Report

FCC Part15 Subpart C& RSS-247 Issue 2

Product Name : Push Button
Model No. : TBPB100-915
FCC ID : 2AMUGTBPB100
IC : 22980-TBPB100

Applicant : TrackNet, Inc

Address : 900 Lafayette Street #329 Santa Clara, CA 95050 USA

Date of Receipt : Aug. 22, 2017
Test Date : Aug. 22, 2017~ Dec. 01, 2017
Issued Date : Apr. 10, 2018
Report No. : 1782102R-RF-US-P06V01
Report Version : V 2.1

The test results relate only to the samples tested.

The test results shown in the test report are traceable to the national/international standard through the calibration of the equipment and evaluated measurement uncertainty herein.

This report must not be used to claim product endorsement by A2LA, TAF or any agency of the government.

The test report shall not be reproduced without the written approval of DEKRA Testing & Certification (Suzhou) Co., Ltd.

Test Report Certification

Issued Date : Apr. 10, 2018

Report No. : 1782102R-RF-US-P06V01



Product Name : Push Button
 Applicant : TrackNet, Inc
 Address : 900 Lafayette Street #329 Santa Clara, CA 95050 USA
 Manufacturer : FLEXTRONICS COMPUTING (SUZHOU) CO., LTD
 Address : No. 1 Guanpu Road, Guoxiang Street, Wuzhong District
 Suzhou, Jiangsu, China, 215124
 Model No. : TBPB100-915
 FCC ID : 2AMUGTBPB100
 IC : 22980-TBPB100
 EUT Voltage : DC 3.7V
 Test Voltage : AC120V/60Hz
 Applicable Standard : FCC CFR Title 47 Part 15 Subpart C: 2017
 KDB DA 00-705 Released March 30, 2000
 ANSI C63.10: 2013
 ISED RSS-Gen Issue 4 / RSS-247 Issue 2
 Test Result : Complied
 Performed Location : DEKRA Testing & Certification (Suzhou) Co., Ltd.
 No.99 Hongye Rd., Suzhou Industrial Park, Suzhou, 215006,
 Jiangsu, China
 TEL: +86-512-6251-5088 / FAX: +86-512-6251-5098
 FCC Registration Number: CN1199

Documented By : Kitty Li

(Project Assistant: Kitty Li)

Reviewed By : Frank He

(Senior Engineer: Frank He)

Approved By : Harry Zhao

(Engineering Manager: Harry Zhao)

TABLE OF CONTENTS

Description	Page
1. General Information	7
1.1. EUT Description	7
1.2. Antenna information	9
1.3. Mode of Operation	10
1.4. Tested System Details.....	11
1.5. Configuration of Tested System	12
1.6. EUT Exercise Software	13
2. Technical Test.....	14
2.1. Summary of Test Result	14
2.2. Test Environment	16
3. Conducted Emission	17
3.1. Test Equipment	17
3.2. Test Setup	17
3.3. Limit.....	18
3.4. Test Procedure	18
3.5. Uncertainty	18
3.6. Test Result	19
4. Emissions in restricted frequency bands.....	21
4.1. Test Equipment	21
4.2. Test Setup	22
4.3. Limit.....	23
4.4. Test Procedure	26
4.5. Uncertainty	26
4.6. Test Result	27
5. 20dB Bandwidth	35
5.1 Test Equipment	35
5.2 Test Setup	35
5.3 Limit.....	35
5.4 Test Procedure	36
5.5 Uncertainty	36
5.6 Test Result	37
6. Carrier Frequency Separation.....	39
6.1. Test Equipment	39
6.2. Test Setup	39
6.3. Limit.....	40
6.4. Test Procedure	40
6.5. Uncertainty	40

6.6.	Test Result	41
7.	Number of Hopping Frequencies	43
7.1.	Test Equipment	43
7.2.	Test Setup	43
7.3.	Limit.....	43
7.4.	Test Procedure	44
7.5.	Uncertainty	44
7.6.	Test Result	45
8.	Time of Occupancy (Dwell Time)	46
8.1.	Test Equipment	46
8.2.	Test Setup	46
8.3.	Limit.....	46
8.4.	Test Procedure	47
8.5.	Uncertainty	47
8.6.	Test Result	48
9.	Peak Output Power	51
9.1.	Test Equipment	51
9.2.	Test Setup	51
9.3.	Limit.....	52
9.4.	Test Procedure	52
9.5.	Uncertainty	52
9.6.	Test Result	53
10.	Emissions in non-restricted frequency bands	54
10.1.	Test Equipment	54
10.2.	Test Setup	54
10.3.	Limit.....	55
10.4.	Test Procedure	55
10.5.	Uncertainty	55
10.6.	Test Result	56
11.	Radiated Emission Band Edge	57
11.1.	Test Equipment	57
11.2.	Test Setup	57
11.3.	Limit.....	58
11.4.	Test Procedure	58
11.5.	Uncertainty	58
11.6.	Test Result	59
12.	Antenna Requirement	64
12.1.	Limit.....	64

12.2. Antenna Connector Construction64

History of This Test Report

REPORT NO.	VERSION	DESCRIPTION	ISSUED DATE
1782102R-RF-US-P06V01	V1.0	Initial Issued Report	Dec. 18, 2017
1782102R-RF-US-P06V01	V2.0	Update Model No. and Antenna Gain	Dec. 22, 2017
1782102R-RF-US-P06V01	V2.1	<ol style="list-style-type: none"> 1. In Page 48-50, added the Time of Occupancy with the configuration of minimum number hopping channels data and description 2. In Page 63, added the Power Spectral Density data 	Apr. 10, 2018

1. General Information

1.1. EUT Description

Product Name	Push Button
Model No.	TBPB100-915
Working Voltage	DC 3.7V
Test Voltage	120V/60Hz
Frequency Range	902- 928 MHz
Channel Number	64
Channel Separation	200kHz
Type of Modulation	LoRa
Data Rate	DR0~DR3:980bps/1760bps/3125bps/5470bps
Antenna Type	Reference to Antenna List
Peak Antenna Gain	Reference to Antenna List

Note: The power of DR1-DR3 is less than the power of DR0, so only DR0 mode was performed.

Working Frequency of Each Channel							
Channel	Frequency	Channel	Frequency	Channel	Frequency	Channel	Frequency
00	902.3 MHz	01	902.5 MHz	02	902.7 MHz	03	902.9 MHz
04	903.1 MHz	05	903.3 MHz	06	903.5 MHz	07	903.7 MHz
08	903.9 MHz	09	904.1 MHz	10	904.3 MHz	11	904.5 MHz
12	904.7 MHz	13	904.9 MHz	14	905.1 MHz	15	905.3 MHz
16	905.5 MHz	17	905.7 MHz	18	905.9 MHz	19	906.1 MHz
20	906.3 MHz	21	906.5 MHz	22	906.7 MHz	23	906.9 MHz
24	907.1 MHz	25	907.3 MHz	26	907.5 MHz	27	907.7 MHz
28	907.9 MHz	29	908.1 MHz	30	908.3 MHz	31	908.5 MHz
32	908.7 MHz	33	908.9 MHz	34	909.1 MHz	35	909.3 MHz
36	909.5 MHz	37	909.7 MHz	38	909.9 MHz	39	910.1 MHz
40	910.3 MHz	41	910.5 MHz	42	910.7 MHz	43	910.9 MHz
44	911.1 MHz	45	911.3 MHz	46	911.5 MHz	47	911.7 MHz
48	911.9 MHz	49	912.1 MHz	50	912.3 MHz	51	912.5 MHz
52	912.7 MHz	53	912.9 MHz	54	913.1 MHz	55	913.3 MHz
56	913.5 MHz	57	913.7 MHz	58	913.9 MHz	59	914.1 MHz
60	914.3 MHz	61	914.5 MHz	62	914.7 MHz	63	914.9 MHz

1.2. Antenna information

Model No.	N/A		
Antenna manufacturer	N/A		
Antenna Delivery	<input checked="" type="checkbox"/> 1*TX+1*RX	<input type="checkbox"/> 2*TX+2*RX	<input type="checkbox"/> 3*TX+3*RX
Antenna technology	<input checked="" type="checkbox"/> SISO		
	<input type="checkbox"/> MIMO	<input type="checkbox"/> Basic	
		<input type="checkbox"/> CDD	
		<input type="checkbox"/> Beam-forming	
Antenna Type	<input type="checkbox"/> External	<input type="checkbox"/> Dipole	
	<input checked="" type="checkbox"/> Internal	<input checked="" type="checkbox"/> PIFA	
		<input type="checkbox"/> PCB	
		<input type="checkbox"/> Ceramic Chip Antenna	
		<input type="checkbox"/> Metal plate type F antenna	
		<input type="checkbox"/> Printed Antenna	
Antenna Gain	-1.69dBi		

1.3. Mode of Operation

DEKRA has verified the construction and function in typical operation. All the test modes were carried out with the EUT in normal operation, which was shown in this test report and defined as:

Test Mode
Mode 1: Transmit

Note:

1. For portable device, radiated spurious emission was verified over X, Y, Z Axis, and shown the worst case on this report.
2. Regards to the frequency band operation for systems using FHSS modulation: normal operation (hopping) was selected to test for conducted spurious test.
3. The extreme test condition for voltage and temperature were declared by the manufacturer.
4. The reading values of all the test items contain cable loss.

1.4. Tested System Details

The types for all equipment, plus descriptions of all cables used in the tested system (including inserted cards) are:

Product	Manufacturer	Model No.	Serial No.	Power Cord
1 Notebook	Think Pad	2526	LV-A3285	Power by adapter
A USB Cable	N/A	N/A	N/A	Shield, 0.75m
B Serial Cable	N/A	N/A	N/A	Shield, 0.75m
C USB Cable	N/A	N/A	N/A	Shield, 10m
D Serial Cable	N/A	N/A	N/A	Shield, 10m

1.5. Configuration of Tested System

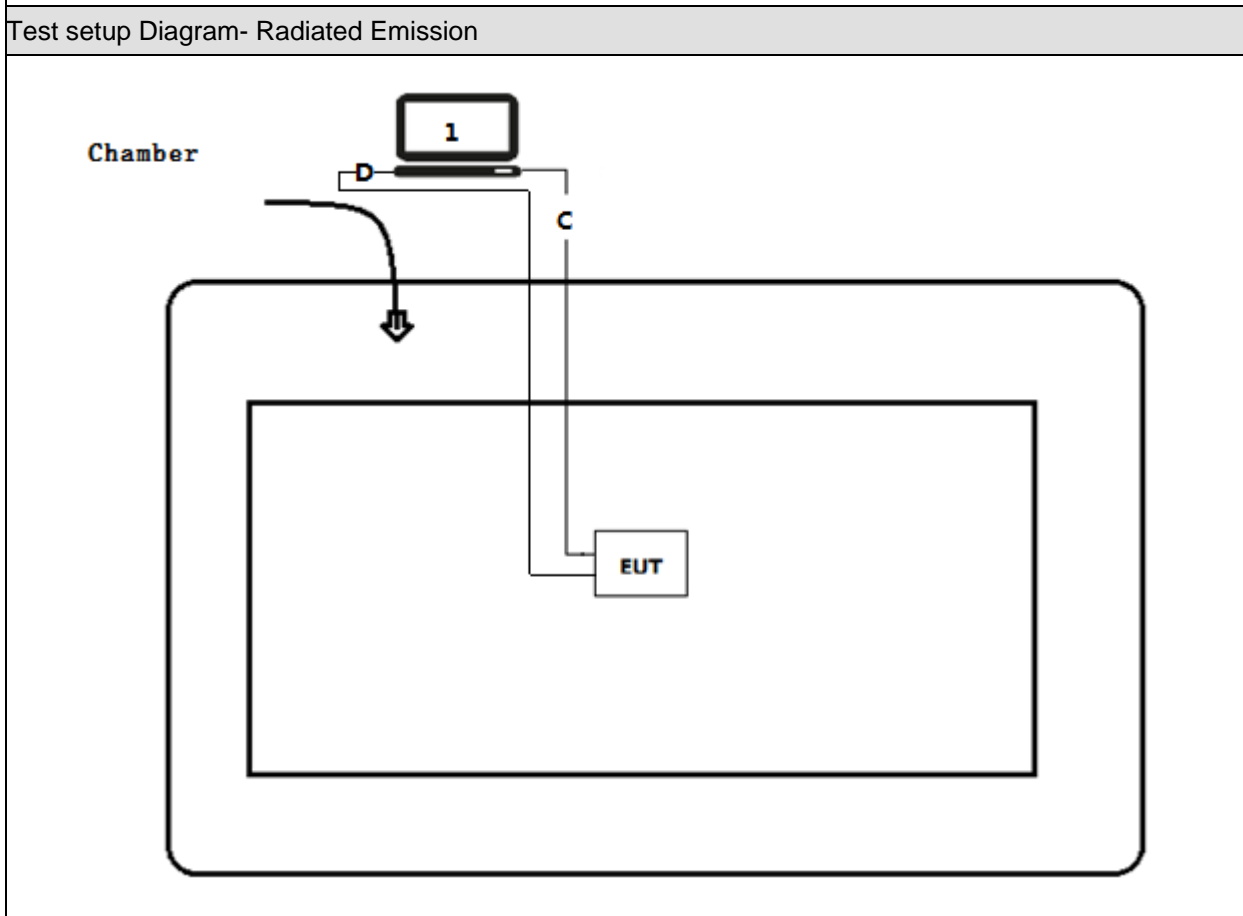
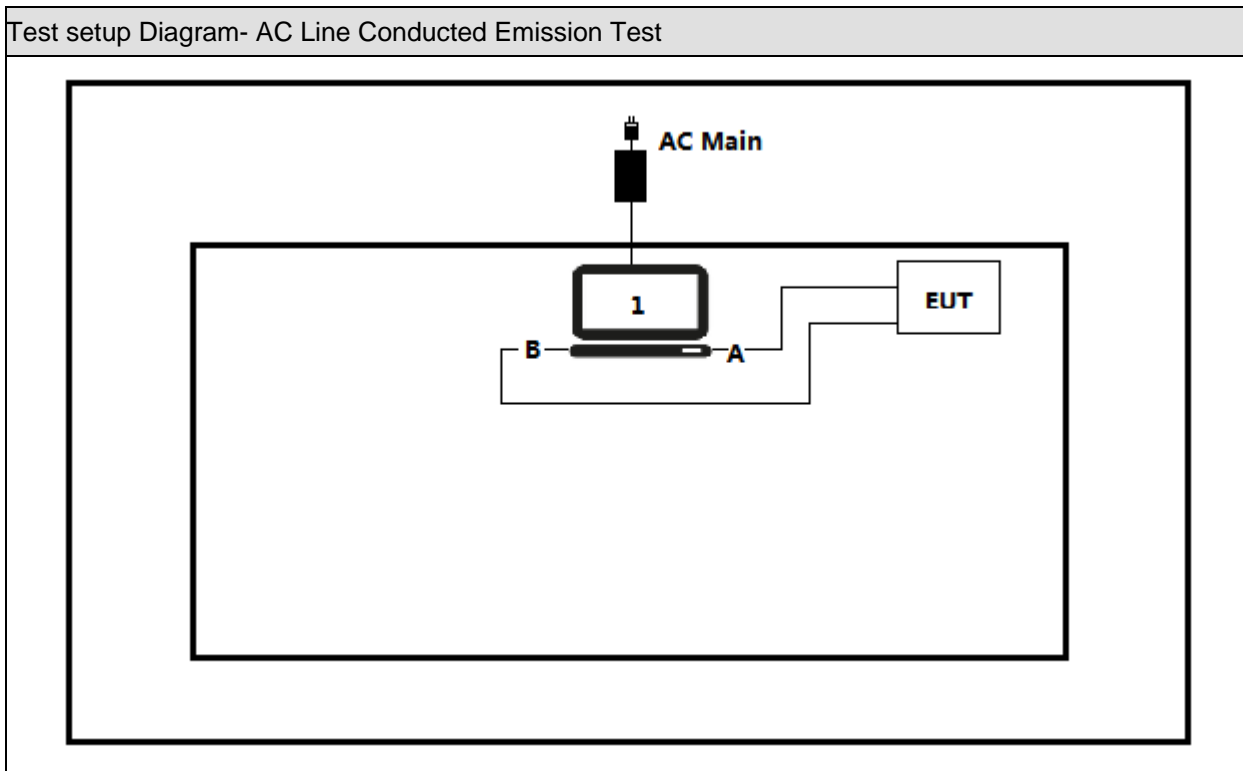

1.6. EUT Exercise Software

1	Setup the EUT and simulators as shown on above.
2	Turn on the power of all equipment.
3	Run "cmd", and set the test mode and channel, then start continue Transmit.

2. Technical Test

2.1. Summary of Test Result

Performed Test Item	Normative References	Test Performed	Deviation
Conducted Emission	FCC CFR Title 47 Part 15 Subpart C: 2015 Section 15.207	Yes	No
Emissions in restricted frequency bands	FCC CFR Title 47 Part 15 Subpart C: 2015 Section 15.209	Yes	No
20dB Bandwidth	FCC CFR Title 47 Part 15 Subpart C: 2015 Section 15.247(a)(1)	Yes	No
Carrier Frequency Separation	FCC CFR Title 47 Part 15 Subpart C: 2015 Section 15.247(a)(1)	Yes	No
Number of Hopping Frequencies	FCC CFR Title 47 Part 15 Subpart C: 2015 Section 15.247(a)(1)(iii)	Yes	No
Time of Occupancy (Dwell Time)	FCC CFR Title 47 Part 15 Subpart C: 2015 Section 15.247(a)(1)(iii)	Yes	No
Peak Output Power	FCC CFR Title 47 Part 15 Subpart C: 2015 Section 15.247(b)(1)	Yes	No
Emissions in non-restricted frequency bands	FCC CFR Title 47 Part 15 Subpart C: 2015 Section 15.215(c), 15.247(d)	Yes	No
Radiated Emission Band Edge	FCC CFR Title 47 Part 15 Subpart C: 2015 15.247(d)	Yes	No
Antenna Requirement	FCC CFR Title 47 Part 15 Subpart C: 2015 Section 15.203	Yes	No

For ISED:

Performed Test Item	Normative References	Test Performed	Deviation
Conducted Emission	RSS-Gen Issue 4 Section 8.8	Yes	No
Emissions in restricted frequency bands	RSS-Gen Issue 4 Section 8.9	Yes	No
20dB Bandwidth	RSS-247 Issue 2 Section 5.1	Yes	No
Carrier Frequency Separation	RSS-247 Issue 2 Section 5.1	Yes	No
Number of Hopping Frequencies	RSS-247 Issue 2 Section 5.1	Yes	No
Time of Occupancy (Dwell Time)	RSS-247 Issue 2 Section 5.1	Yes	No
Peak Output Power	RSS-247 Issue 2 Section 5.4	Yes	No
Emissions in non-restricted frequency bands	RSS-247 Issue 2 Section 5.5	Yes	No
Radiated Emission Band Edge	RSS-Gen Issue 4 Section 8.10	Yes	No
Antenna Requirement	RSS-Gen Issue 4 Section 8.3	Yes	No

2.2. Test Environment

Items	Required (IEC 68-1)	Actual
Temperature (°C)	15-35	21
Humidity (%RH)	25-75	50
Barometric pressure (mbar)	860-1060	950-1000

3. Conducted Emission

3.1. Test Equipment

AC Power Line Conducted Emission / TR-1					
Instrument	Manufacturer	Type No.	Serial No.	Cal. Date	Cal. Due Date
EMI Test Receiver	R&S	ESCI	100906	2017.03.05	2018.03.04
Two-Line V-Network	R&S	ENV 216	101189	2017.07.16	2018.07.15
Two-Line V-Network	R&S	ENV 216	101044	2017.09.15	2018.09.15
50ohm Coaxial Switch	Anritsu	MP59B	6200464462	N/A	N/A
50ohm Termination	SHX	TF2	07081402	2017.09.15	2018.09.15
Temperature/Humidity Meter	Zhichen	ZC1-2	TR1-TH	2017.01.05	2018.01.04

Note: All equipments are calibrated with traceable calibrations. Each calibration is traceable to the national or international standards.

3.2. Test Setup

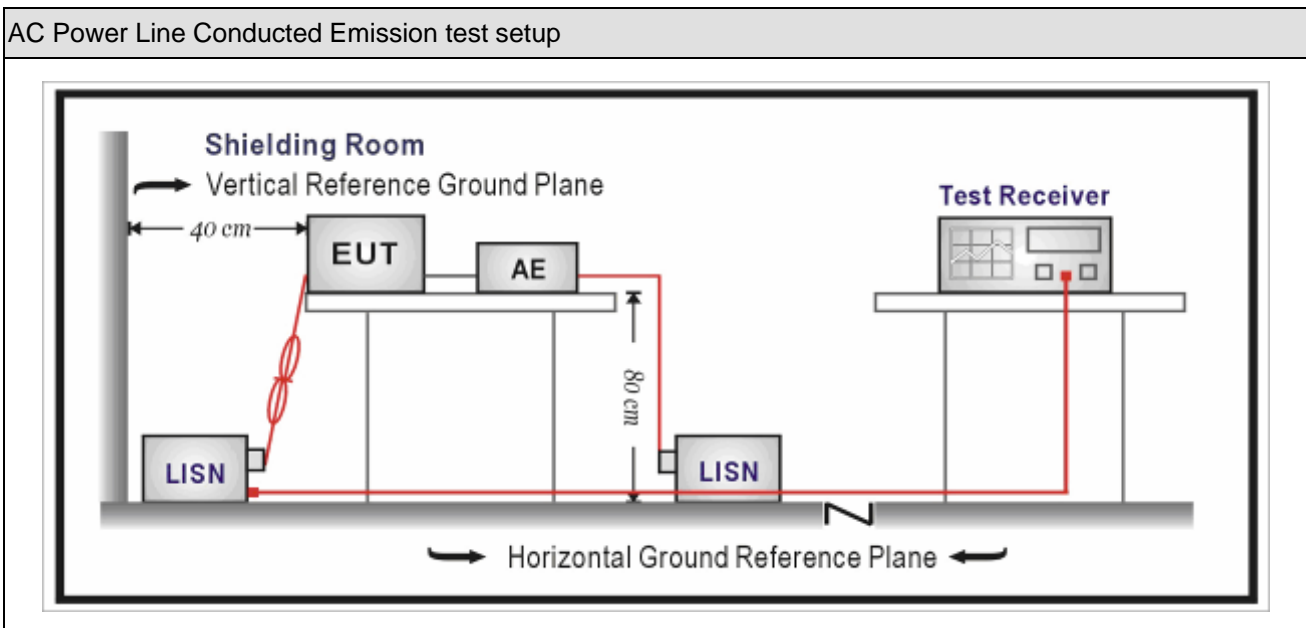

3.3. Limit

Frequency of Emission (MHz)	Conducted Limit	
	Quasi-peak (dB μ V)	Average (dB μ V)
0.15-0.5	66 to 56	56 to 46
0.5-5	56	46
5-30	60	50

Note 1: The lower limit shall apply at the transition frequencies.
 Note 2: The limit decreases linearly with the logarithm of the frequency in the range 0.15 MHz to 0.5 MHz.

3.4. Test Procedure

Test Method			
	References Rule	Chapter	Item
<input checked="" type="checkbox"/>	ANSI C63.10-2013	6.2	Standard test method for ac power-line conducted emissions from unlicensed wireless devices

3.5. Uncertainty

The measurement uncertainty is defined as ± 2.02 dB

3.6. Test Result

Site: TR1	Time: 2017/09/15
Limit: FCC_Part15.207_CE	Margin: 0
Probe: ENV216_101190(0.009-30MHz)	Polarity: Line
EUT: Push Button	Power: AC 120V/60Hz
Note: Mode 1:Transmit at channel 902.3MHz	

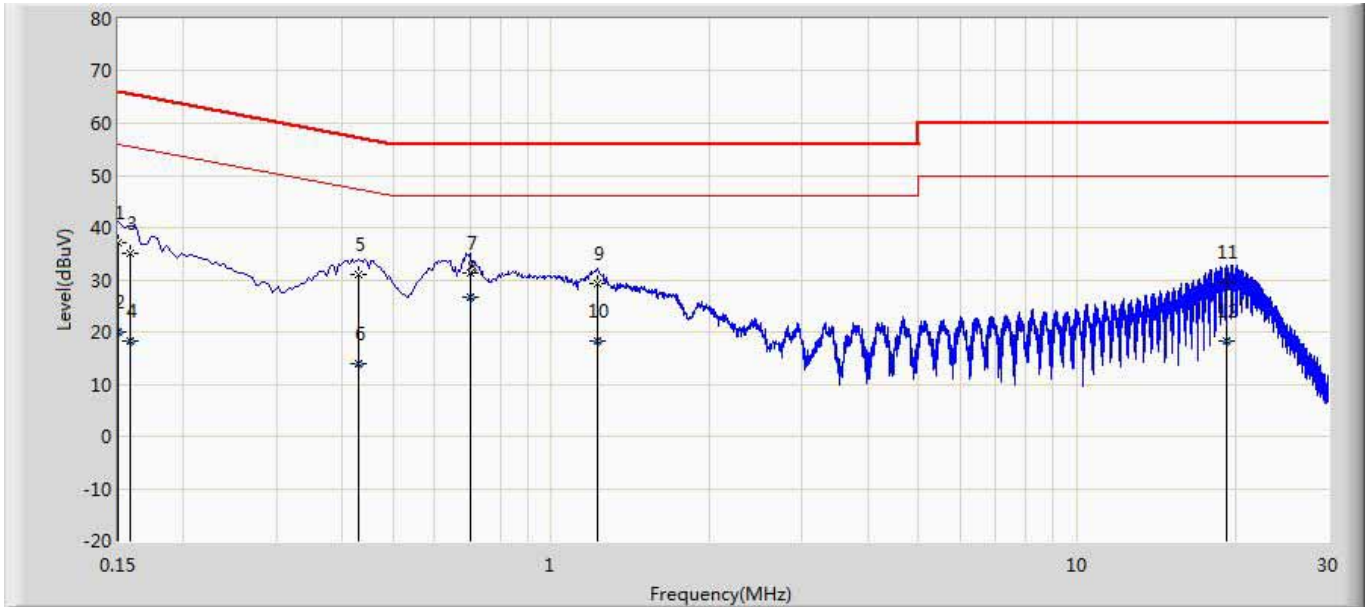

No	Mark	Frequency (MHz)	Measure Level (dBuV)	Reading Level (dBuV)	Over Limit (dB)	Limit (dBuV)	Probe (dB)	Cable (dB)	Amp (dB)	Type
1		0.150	37.079	27.444	-28.921	66.000	9.610	0.025	0.000	QP
2		0.150	20.074	10.440	-35.926	56.000	9.610	0.025	0.000	AV
3		0.158	35.083	25.449	-30.485	65.568	9.608	0.026	0.000	QP
4		0.158	18.285	8.651	-37.283	55.568	9.608	0.026	0.000	AV
5		0.430	30.924	21.284	-26.329	57.253	9.600	0.040	0.000	QP
6		0.430	13.972	4.332	-33.281	47.253	9.600	0.040	0.000	AV
7		0.702	31.443	21.793	-24.557	56.000	9.600	0.050	0.000	QP
8	*	0.702	26.602	16.952	-19.398	46.000	9.600	0.050	0.000	AV
9		1.226	29.336	19.660	-26.664	56.000	9.610	0.066	0.000	QP
10		1.226	18.123	8.447	-27.877	46.000	9.610	0.066	0.000	AV
11		19.286	29.443	19.054	-30.557	60.000	10.106	0.283	0.000	QP
12		19.286	18.123	7.735	-31.877	50.000	10.106	0.283	0.000	AV

Site: TR1	Time: 2017/09/15
Limit: FCC_Part15.207_CE	Margin: 0
Probe: ENV216_101190(0.009-30MHz)	Polarity: Neutral
EUT: Push Button	Power: AC 120V/60Hz
Note: Mode 1:Transmit at channel 902.3MHz	

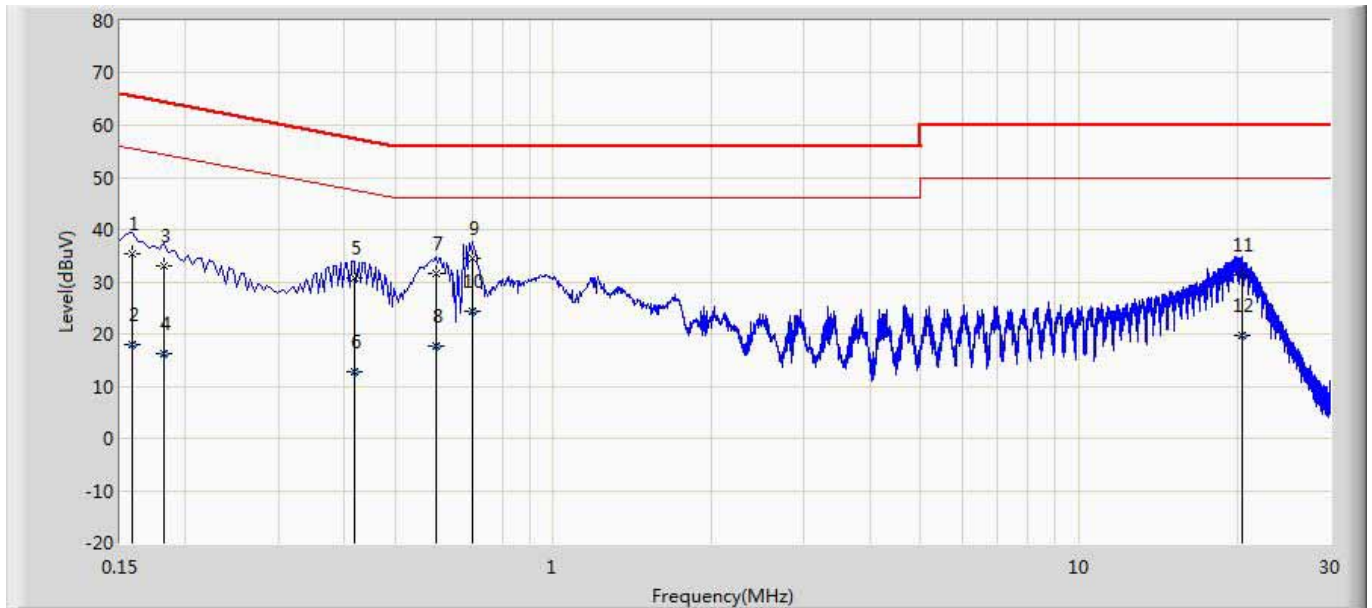

No	Mark	Frequency (MHz)	Measure Level (dBuV)	Reading Level (dBuV)	Over Limit (dB)	Limit (dBuV)	Probe (dB)	Cable (dB)	Amp (dB)	Type
1		0.158	35.351	25.733	-30.218	65.568	9.592	0.026	0.000	QP
2		0.158	17.888	8.270	-37.681	55.568	9.592	0.026	0.000	AV
3		0.182	32.984	23.359	-31.410	64.394	9.597	0.028	0.000	QP
4		0.182	16.263	6.638	-38.131	54.394	9.597	0.028	0.000	AV
5		0.418	30.776	21.145	-26.712	57.488	9.592	0.039	0.000	QP
6		0.418	12.716	3.085	-34.771	47.488	9.592	0.039	0.000	AV
7		0.598	31.710	22.074	-24.290	56.000	9.590	0.046	0.000	QP
8		0.598	17.794	8.158	-28.206	46.000	9.590	0.046	0.000	AV
9	*	0.702	34.354	24.714	-21.646	56.000	9.590	0.050	0.000	QP
10		0.702	24.266	14.626	-21.734	46.000	9.590	0.050	0.000	AV
11		20.374	31.291	20.783	-28.709	60.000	10.216	0.291	0.000	QP
12		20.374	19.796	9.289	-30.204	50.000	10.216	0.291	0.000	AV

4. Emissions in restricted frequency bands

4.1. Test Equipment

Radiated Emission(Below 1GHz) / AC-2					
Instrument	Manufacturer	Type No.	Serial No.	Cal. Date	Cal. Due Date
EMI Test Receiver	R&S	ESCI	100573	2017.03.29	2018.03.28
Loop Antenna	R&S	HFH2-Z2	833799/003	2017.11.16	2018.11.15
Bilog Antenna	Teseq GmbH	CBL6112D	27611	2017.10.16	2018.10.15
Coaxial Cable	Huber+Suhner	SUCOFLEX 106	AC2-C	2017.03.02	2018.03.01
Temperature/Humidity Meter	Zhichen	ZC1-2	AC2-TH	2017.01.04	2018.01.03
Note: All equipments are calibrated with traceable calibrations. Each calibration is traceable to the national or international standards.					

Radiated Emission(Above 1GHz) / AC-5					
Instrument	Manufacturer	Type No.	Serial No.	Cal. Date	Cal. Due Date
Spectrum Analyzer	Agilent	E4446A	MY45300103	2017.01.04	2018.01.03
Preamplifier	Miteq	NSP1800-25	1364185	2017.05.06	2018.05.05
Preamplifier	QuieTek	AP-040G	CHM-0906001	2017.05.06	2018.05.05
DRG Horn	ETS-Lindgren	3117	00123988	2017.01.22	2018.01.21
Broad-Band Horn Antenna	Schwarzbeck	BBHA9170	294	2017.11.25	2018.11.24
Coaxial Cable	Huber+Suhner	SUCOFLEX 106	AC5-C1	2017.03.02	2018.03.01
Coaxial Cable	Huber+Suhner	SUCOFLEX 106	AC5-C2	2017.03.02	2018.03.01
Coaxial Cable	Huber+Suhner	SUCOFLEX 102	AC5-C3	2017.03.02	2018.03.01
EMI Receiver	Agilent	N9038A	MY51210196	2017.06.10	2018.06.09
Temperature/Humidity Meter	Zhichen	ZC1-2	AC5-TH	2017.01.04	2018.01.03
Note: All equipments are calibrated with traceable calibrations. Each calibration is traceable to the national or international standards.					

4.2. Test Setup

Below 30MHz Test Setup:

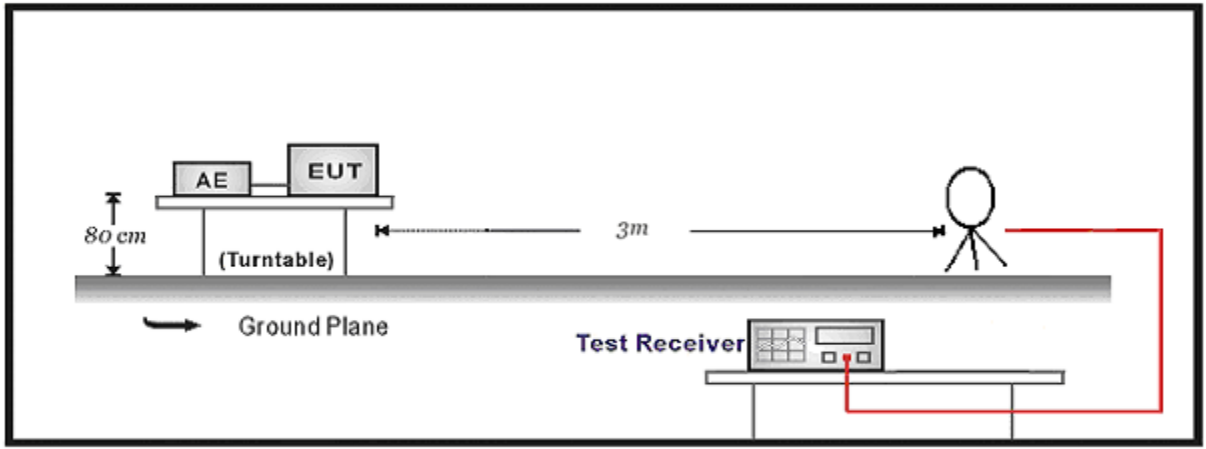

30MHz-1GHz Test Setup:

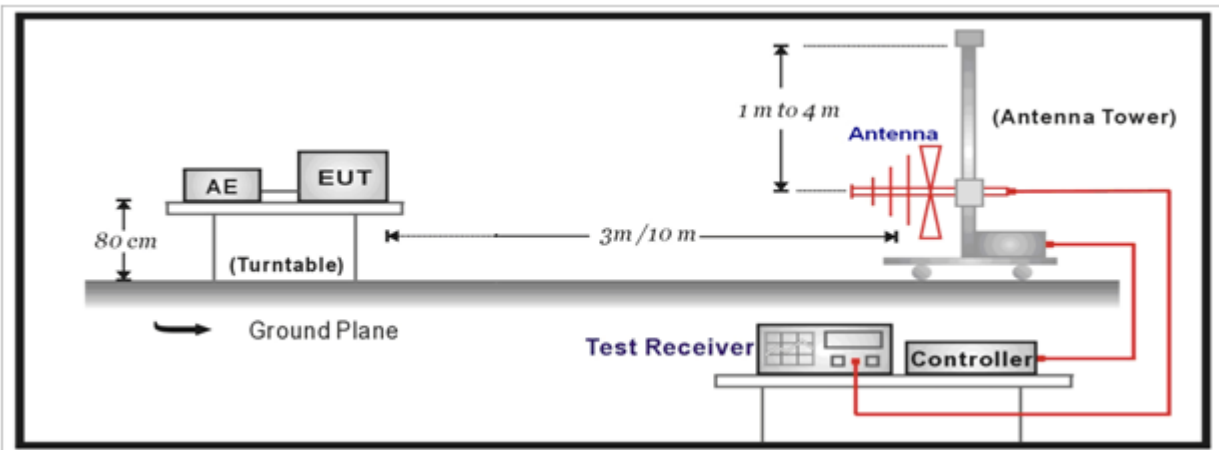

Above 1GHz Test Setup:

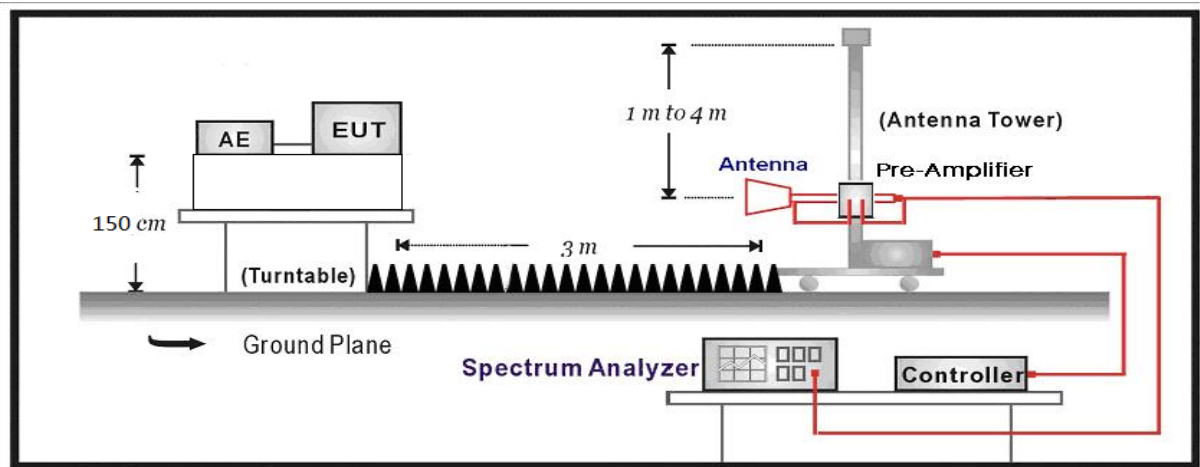

4.3. Limit

For FCC:

Restricted Bands of operation			
Frequency (MHz)	Frequency (MHz)	Frequency (MHz)	Frequency (GHz)
0.090 – 0.110	16.42 – 16.423	399.9 – 410	4.5 – 5.15
0.495 – 0.505	16.69475 – 16.69525	608 – 614	5.35 – 5.46
2.1735 – 2.1905	16.80425 – 16.80475	960 – 1240	7.25 – 7.75
4.125 – 4.128	25.5 – 25.67	1300 – 1427	8.025 – 8.5
4.17725 – 4.17775	37.5 – 38.25	1435 – 1626.5	9.0 – 9.2
4.20725 – 4.20775	73 – 74.6	1645.5 – 1646.5	9.3 – 9.5
6.215 – 6.218	74.8 – 75.2	1660 – 1710	10.6 – 12.7
6.26775 – 6.26825	108 – 121.94	1718.8 – 1722.2	13.25 – 13.4
6.31175 – 6.31225	123 – 138	2200 – 2300	14.47 – 14.5
8.291 – 8.294	149.9 – 150.05	2310 – 2390	15.35 – 16.2
8.362 – 8.366	156.52475 – 156.52525	2483.5 – 2500	17.7 – 21.4
8.37625 – 8.38675	156.7 – 156.9	2690 – 2900	22.01 – 23.12
8.81425 – 8.81475	162.0125 – 167.17	3260 – 3267	23.6 – 24.0
12.29 – 12.293	167.72 – 173.2	3332 – 3339	31.2 – 31.8
12.51975 – 12.52025	240 – 285	3345.8 – 3358	36.43 – 36.5
12.57675 – 12.57725	322 – 335.4	3600 – 4400	
13.36 – 13.41			

For ISED:

Restricted Bands of operation			
Frequency (MHz)	Frequency (MHz)	Frequency (MHz)	Frequency (GHz)
0.090-0.110	13.36-13.41	1645.5-1646.5	13.25-13.4
2.1735-2.1905	16.42-16.423	1660-1710	14.47-14.5
3.020-3.026	16.69475-16.69525	1718.8-1722.2	15.35-16.2
4.125-4.128	16.80425-16.80475	2200-2300	17.7-21.4
4.17725-4.17775	25.5-25.67	2310-2390	22.01-23.12
4.20725-4.20775	37.5-38.25	2655-2900	23.6-24.0
5.677-5.683	73-74.6	3260-3267	31.2-31.8
6.215-6.218	74.8-75.2	3332-3339	36.43-36.5
6.26775-6.26825	108-138	3345.8-3358	Above 38.6
6.31175-6.31225	156.52475-156.52525	3500-4400	
8.291-8.294	156.7-156.9	4500-5150	
8.362-8.366	240-285	5350-5460	
8.37625-8.38675	322-335.4	7250-7750	
8.41425-8.41475	399.9-410	8025-8500	
12.29-12.293	608-614	9.0-9.2	
12.51975-12.52025	960-1427	9.3-9.5	
12.57675-12.57725	1435-1626.5	10.6-12.7	

Restricted Band Emissions Limit			
Frequency (MHz)	Field strength (μ V/m)	Field strength (dB μ V/m)	Measurement distance (m)
0.009 - 0.49	2400/F(kHz)	48.5 – 13.8	300 _(Note 1)
0.49 - 1.705	24000/F(kHz)	33.8 - 23	30 _(Note 1)
1.705 - 30	30	29.5	30 _(Note 1)
30 - 88	100	40	3 _(Note 2)
88 - 216	150	43.5	3 _(Note 2)
216 - 960	200	46	3 _(Note 2)
Above 960	500	54	3 _(Note 2)

Note 1: At frequencies below 30 MHz, measurements may be performed at a distance closer than that specified in the regulations; however, an attempt should be made to avoid making measurements in the near field. Pending the development of an appropriate measurement procedure for measurements performed below 30 MHz, when performing measurements at a closer distance than specified, the results shall be extrapolated to the specified distance by either making measurements at a minimum of two distances on at least one radial to determine the proper extrapolation factor or by using the square of an inverse linear distance extrapolation factor (40 dB/decade).

Note 2: At frequencies at or above 30 MHz, measurements may be performed at a distance other than what is specified provided: measurements are not made in the near field except where it can be shown that near field measurements are appropriate due to the characteristics of the device; and it can be demonstrated that the signal levels needed to be measured at the distance employed can be detected by the measurement equipment. Measurements shall not be performed at a distance greater than 30 meters unless it can be further demonstrated that measurements at a distance of 30 meters or less are impractical. When performing measurements at a distance other than that specified, the results shall be extrapolated to the specified distance using an extrapolation factor of 20 dB/decade (inverse linear-distance for field strength measurements; inverse-linear-distance-squared for power density measurements).

4.4. Test Procedure

Test Method			
	References Rule	Chapter	Description
<input checked="" type="checkbox"/>	ANSI C63.10	6.4	Radiated emissions from unlicensed wireless devices below 30 MHz
<input checked="" type="checkbox"/>	ANSI C63.10	6.5	Radiated emissions from unlicensed wireless devices in the frequency range of 30 MHz to 1000 MHz
<input checked="" type="checkbox"/>	ANSI C63.10	6.6	Radiated emissions from unlicensed wireless devices above 1 GHz

4.5. Uncertainty

The measurement uncertainty above 1G is defined as ± 3.9 dB
below 1G is defined as ± 3.8 dB

4.6. Test Result

Site: AC5	Time: 2017/11/21 - 14:40
Limit: FCC_Part15.209_RE(3m)	Margin: 0
Probe: Horn_3117_00167055(1-18GHz)	Polarity: Horizontal
EUT: Push Button	Power: 120V/60Hz
Note: Mode 1:Transmit at channel 902.3MHz	

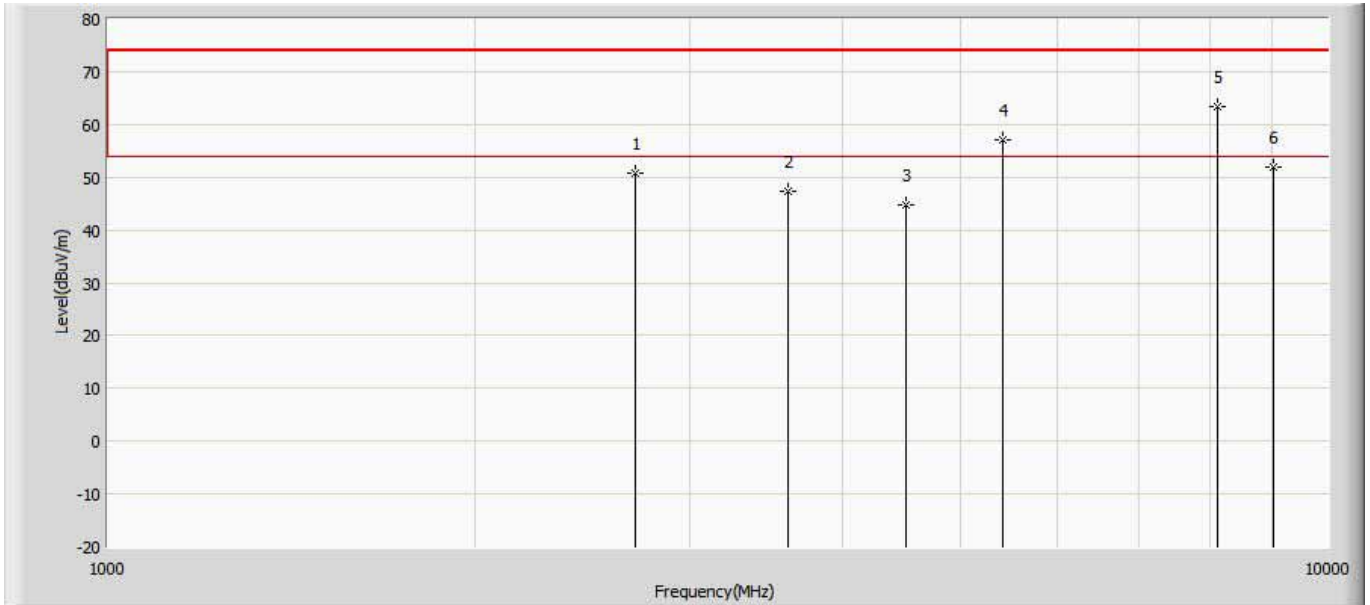

No	Mark	Frequency (MHz)	Measure Level (dBuV/m)	Reading Level (dBuV)	Over Limit (dB)	Limit (dBuV/m)	Factor (dB)	Type
1		2705.500	50.854	67.804	-23.146	74.000	-16.950	PK
2		3610.000	47.417	62.057	-26.583	74.000	-14.640	PK
3		4510.000	44.774	57.784	-29.226	74.000	-13.010	PK
4		5414.500	57.218	69.448	-16.782	74.000	-12.230	PK
5	*	8119.000	63.450	68.350	-10.550	74.000	-4.900	PK
6		9023.500	52.035	53.875	-21.965	74.000	-1.840	PK

No	Mark	Frequency (MHz)	PK Level (dBuV/m)	AV Level (dBuV)	Over Limit (dB)	Limit (dBuV/m)	Factor (dB)	Type
1		2705.500	50.854	33.594	-20.406	54.000	-17.260	AV
2		3610.000	47.417	30.157	-23.843	54.000	-17.260	AV
3		4510.000	44.774	27.514	-26.486	54.000	-17.260	AV
4		5414.500	57.218	39.958	-14.042	54.000	-17.260	AV
5	*	8119.000	63.450	46.190	-7.810	54.000	-17.260	AV
6		9023.500	52.035	34.775	-19.225	54.000	-17.260	AV

Site: AC5	Time: 2017/11/21 - 14:40
Limit: FCC_Part15.209_RE(3m)	Margin: 0
Probe: Horn_3117_00167055(1-18GHz)	Polarity: Vertical
EUT: Push Button	Power: 120V/60Hz
Note: Mode 1: Transmit at channel 902.3MHz	

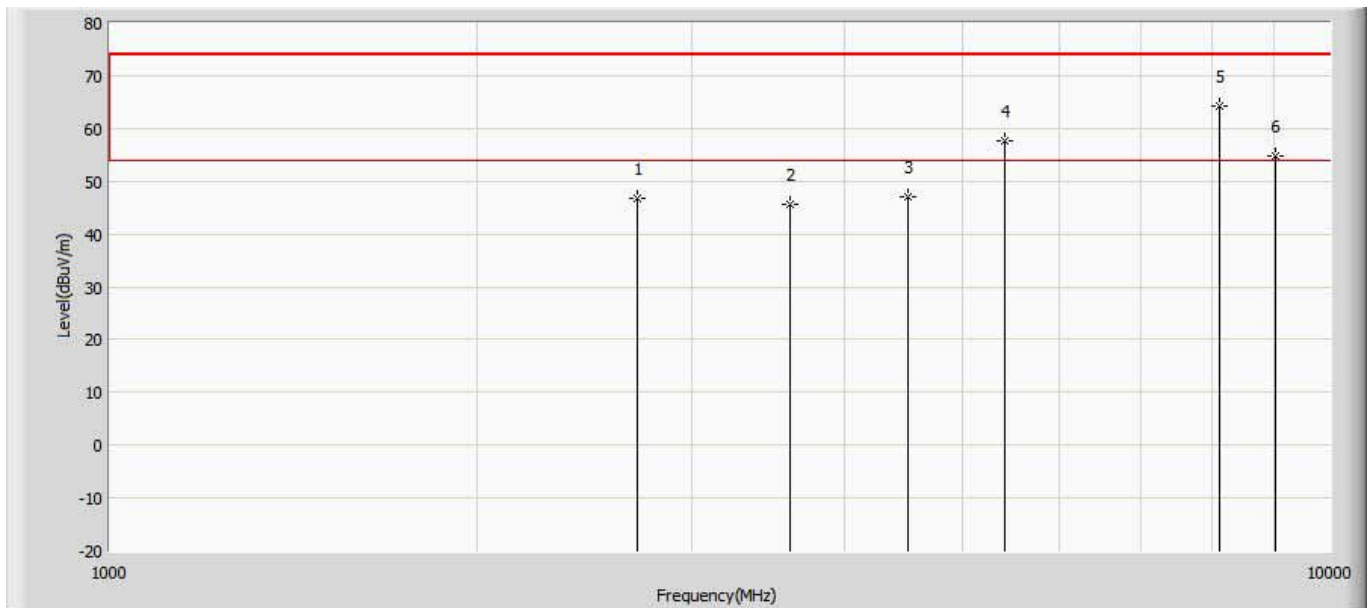

No	Mark	Frequency (MHz)	Measure Level (dBuV/m)	Reading Level (dBuV)	Over Limit (dB)	Limit (dBuV/m)	Factor (dB)	Type
1		2705.500	46.689	63.639	-27.311	74.000	-16.950	PK
2		3610.000	45.520	60.160	-28.480	74.000	-14.640	PK
3		4510.000	47.061	60.071	-26.939	74.000	-13.010	PK
4		5414.500	57.526	69.756	-16.474	74.000	-12.230	PK
5	*	8119.000	64.287	69.187	-9.713	74.000	-4.900	PK
6		9023.500	54.884	56.724	-19.116	74.000	-1.840	PK

No	Mark	Frequency (MHz)	PK Level (dBuV/m)	AV Level (dBuV)	Over Limit (dB)	Limit (dBuV/m)	Factor (dB)	Type
1		2705.500	46.689	29.429	-24.571	54.000	-17.260	AV
2		3610.000	45.520	28.260	-25.740	54.000	--17.260	AV
3		4510.000	47.061	29.801	-24.199	54.000	-17.260	AV
4		5414.500	57.526	40.266	-13.734	54.000	-17.260	AV
5	*	8119.000	64.287	47.027	-6.973	54.000	-17.260	AV
6		9023.500	54.884	37.624	-16.376	54.000	-17.260	AV

Site: AC5	Time: 2017/11/21 - 14:40
Limit: FCC_Part15.209_RE(3m)	Margin: 0
Probe: Horn_3117_00167055(1-18GHz)	Polarity: Horizontal
EUT: Push Button	Power: 120V/60Hz
Note: Mode 1:Transmit at channel 908.5MHz	

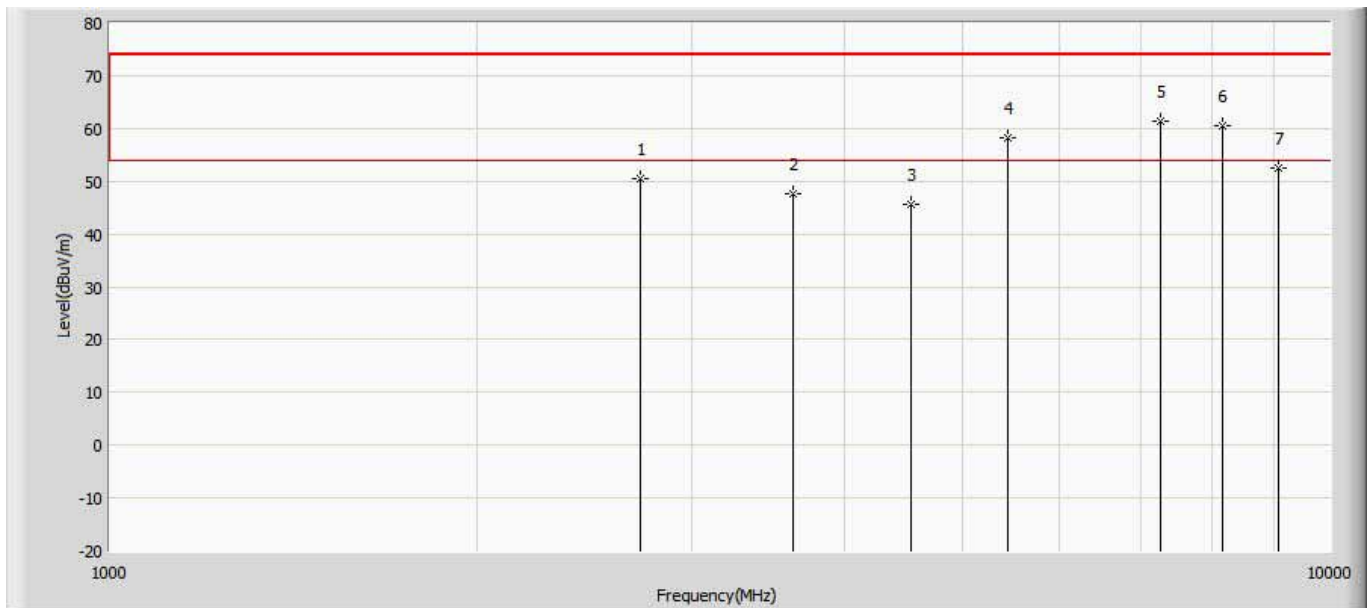

No	Mark	Frequency (MHz)	Measure Level (dBuV/m)	Reading Level (dBuV)	Over Limit (dB)	Limit (dBuV/m)	Factor (dB)	Type
1		2723.500	50.355	67.305	-23.645	74.000	-16.950	PK
2		3632.500	47.490	62.130	-26.510	74.000	-14.640	PK
3		4541.500	45.703	58.713	-28.297	74.000	-13.010	PK
4		5450.500	58.339	69.059	-15.661	74.000	-10.720	PK
5	*	7268.500	61.369	69.079	-12.631	74.000	-7.710	PK
6		8177.500	60.465	65.365	-13.535	74.000	-4.900	PK
7		9086.500	52.447	54.287	-21.553	74.000	-1.840	PK

No	Mark	Frequency (MHz)	PK Level (dBuV/m)	AV Level (dBuV)	Over Limit (dB)	Limit (dBuV/m)	Factor (dB)	Type
1		2723.500	50.355	33.095	-20.905	54.000	-17.260	AV
2		3632.500	47.490	30.230	-23.770	54.000	--17.260	AV
3		4541.500	45.703	28.443	-25.557	54.000	-17.260	AV
4		5450.500	58.339	41.079	-12.921	54.000	-17.260	AV
5	*	7268.500	61.369	44.109	-9.891	54.000	-17.260	AV
6		8177.500	60.465	43.205	-10.795	54.000	-17.260	AV
7		9086.500	52.447	35.187	-18.813	54.000	-17.260	AV

Site: AC5	Time: 2017/11/21 - 14:40
Limit: FCC_Part15.209_RE(3m)	Margin: 0
Probe: Horn_3117_00167055(1-18GHz)	Polarity: Vertical
EUT: Push Button	Power: 120V/60Hz
Note: Mode 1:Transmit at channel 908.5MHz	

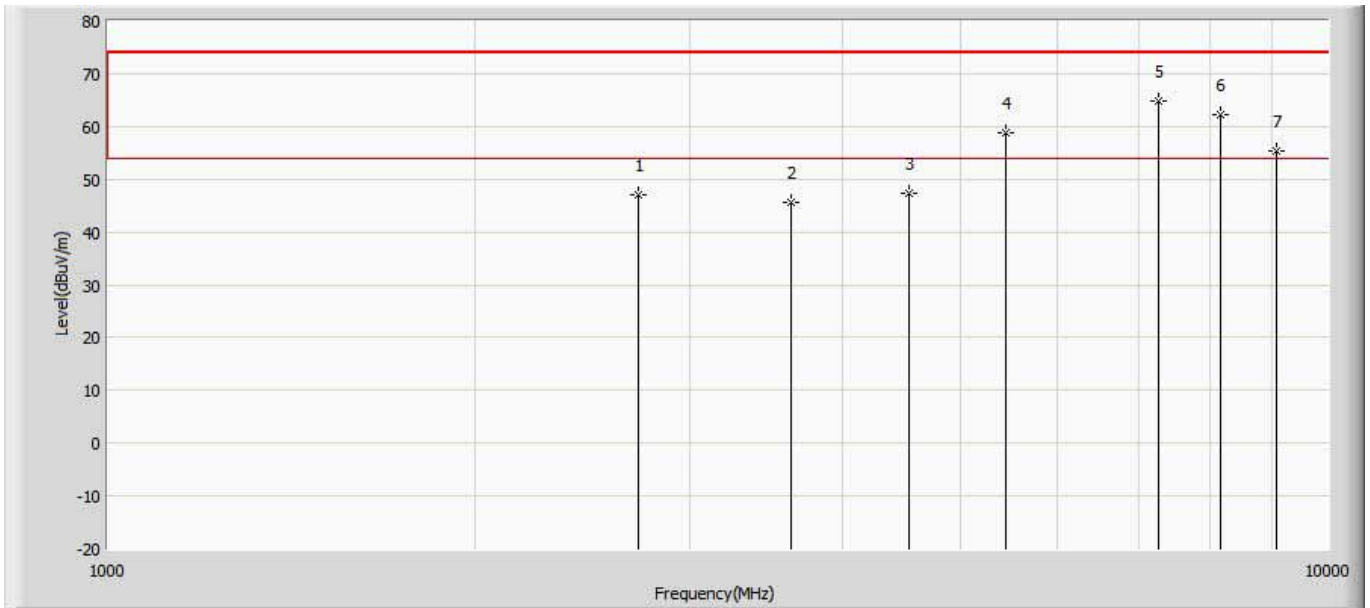

No	Mark	Frequency (MHz)	Measure Level (dBuV/m)	Reading Level (dBuV)	Over Limit (dB)	Limit (dBuV/m)	Factor (dB)	Type
1		2723.500	46.995	63.945	-27.005	74.000	-16.950	PK
2		3632.500	45.555	60.195	-28.445	74.000	-14.640	PK
3		4541.500	47.360	60.370	-26.640	74.000	-13.010	PK
4		5450.500	58.717	69.437	-15.283	74.000	-10.720	PK
5	*	7268.500	64.686	72.396	-9.314	74.000	-7.710	PK
6		8177.500	62.248	67.148	-11.752	74.000	-4.900	PK
7		9086.500	55.271	57.111	-18.729	74.000	-1.840	PK

No	Mark	Frequency (MHz)	PK Level (dBuV/m)	AV Level (dBuV)	Over Limit (dB)	Limit (dBuV/m)	Factor (dB)	Type
1		2723.500	46.995	29.735	-24.265	54.000	-17.260	AV
2		3632.500	45.555	28.295	-25.705	54.000	--17.260	AV
3		4541.500	47.360	30.100	-23.900	54.000	-17.260	AV
4		5450.500	58.717	41.457	-12.543	54.000	-17.260	AV
5	*	7268.500	64.686	47.426	-6.574	54.000	-17.260	AV
6		8177.500	62.248	44.988	-9.012	54.000	-17.260	AV
7		9086.500	55.271	38.011	-15.989	54.000	-17.260	AV

Site: AC5	Time: 2017/11/21 - 14:40
Limit: FCC_Part15.209_RE(3m)	Margin: 0
Probe: Horn_3117_00167055(1-18GHz)	Polarity: Horizontal
EUT: Push Button	Power: 120V/60Hz
Note: Mode 1:Transmit at channel 914.9MHz	

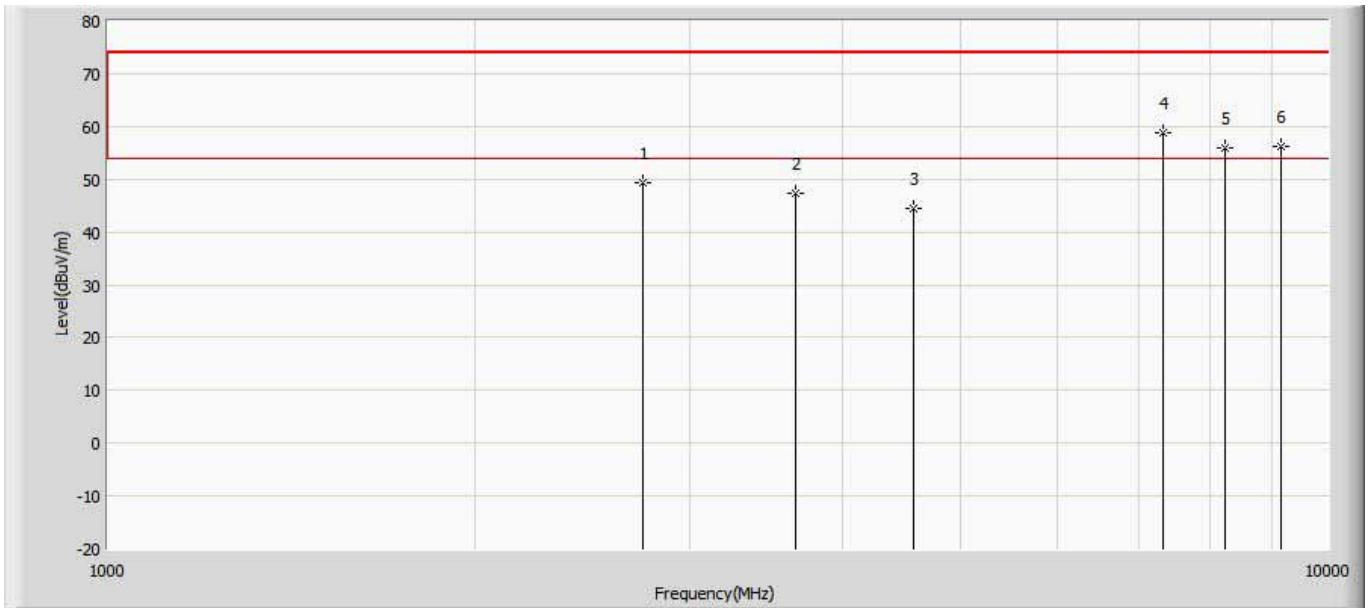

No	Mark	Frequency (MHz)	Measure Level (dBuV/m)	Reading Level (dBuV)	Over Limit (dB)	Limit (dBuV/m)	Factor (dB)	Type
1		2746.000	49.358	66.308	-24.635	74.000	-16.950	PK
2		3659.500	47.264	61.904	-26.702	74.000	-14.640	PK
3		4573.000	44.352	57.362	-29.633	74.000	-13.010	PK
4	*	7318.000	58.783	66.493	-15.225	74.000	-7.710	PK
5		8236.000	55.975	60.875	-18.006	74.000	-4.900	PK
6		9149.500	56.247	58.087	-17.729	74.000	-1.840	PK

No	Mark	Frequency (MHz)	PK Level (dBuV/m)	AV Level (dBuV)	Over Limit (dB)	Limit (dBuV/m)	Factor (dB)	Type
1		2746.000	49.358	32.098	-21.902	54.000	-17.260	AV
2		3659.500	47.264	30.004	-23.996	54.000	--17.260	AV
3		4573.000	44.352	27.092	-26.908	54.000	-17.260	AV
4	*	7318.000	58.783	41.523	-12.477	54.000	-17.260	AV
5		8236.000	55.975	38.715	-15.285	54.000	-17.260	AV
6		9149.500	56.247	38.987	-15.013	54.000	-17.260	AV

Site: AC5	Time: 2017/11/21 - 14:40
Limit: FCC_Part15.209_RE(3m)	Margin: 0
Probe: Horn_3117_00167055(1-18GHz)	Polarity: Vertical
EUT: Push Button	Power: 120V/60Hz
Note: Mode 1:Transmit at channel 914.9MHz	

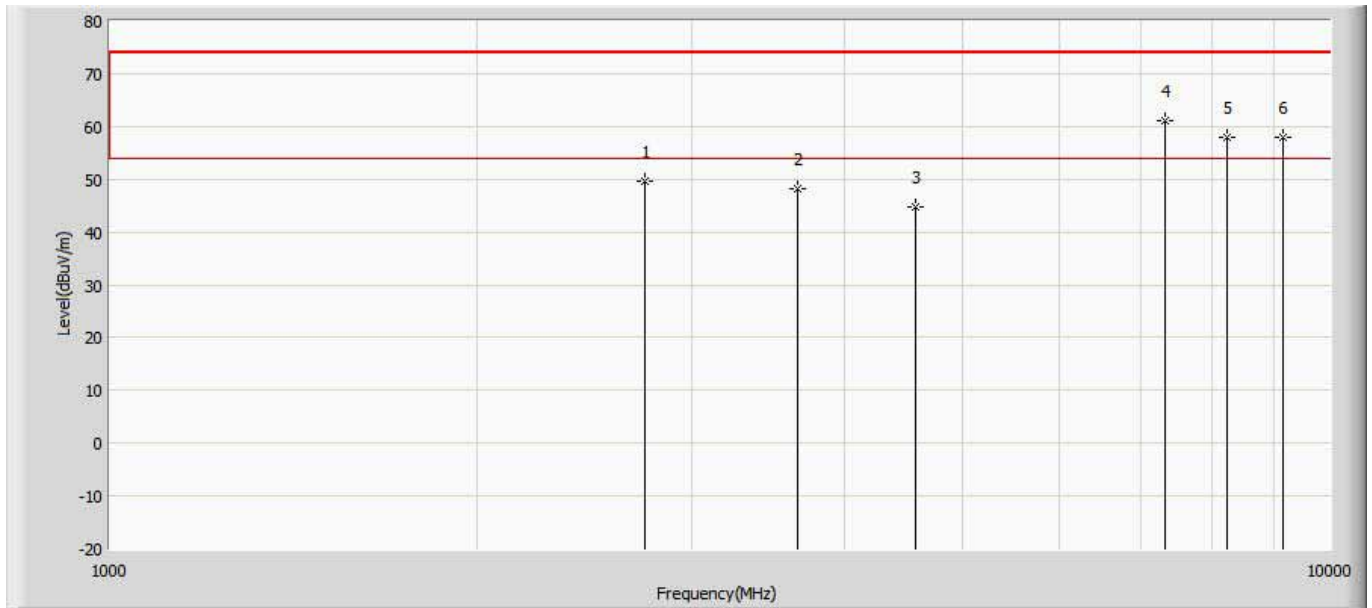

No	Mark	Frequency (MHz)	Measure Level (dBuV/m)	Reading Level (dBuV)	Over Limit (dB)	Limit (dBuV/m)	Factor (dB)	Type
1		2746.000	49.565	66.515	-24.435	74.000	-16.950	PK
2		3659.500	48.098	62.738	-25.902	74.000	-14.640	PK
3		4573.000	44.767	57.777	-29.233	74.000	-13.010	PK
4	*	7318.000	61.075	68.785	-12.925	74.000	-7.710	PK
5		8236.000	57.994	62.894	-16.006	74.000	-4.900	PK
6		9149.500	57.971	59.811	-16.029	74.000	-1.840	PK

No	Mark	Frequency (MHz)	PK Level (dBuV/m)	AV Level (dBuV)	Over Limit (dB)	Limit (dBuV/m)	Factor (dB)	Type
1		2746.000	49.565	32.305	-21.695	54.000	-17.260	AV
2		3659.500	48.098	30.838	-23.162	54.000	--17.260	AV
3		4573.000	44.767	27.507	-26.493	54.000	-17.260	AV
4	*	7318.000	61.075	43.815	-10.185	54.000	-17.260	AV
5		8236.000	57.994	40.734	-13.266	54.000	-17.260	AV
6		9149.500	57.971	40.711	-13.289	54.000	-17.260	AV

The worst case of Radiated Emission below 1GHz:

Site: AC3	Time: 2017/09/19
Limit: FCC_Part15.209_RE(3m)	Margin: 0
Probe: AC3_3m (30-1000MHz)	Polarity: Horizontal
EUT: Push Button	Power: AC 120V/60Hz
Note: Mode 1:Transmit at channel 902.3MHz	

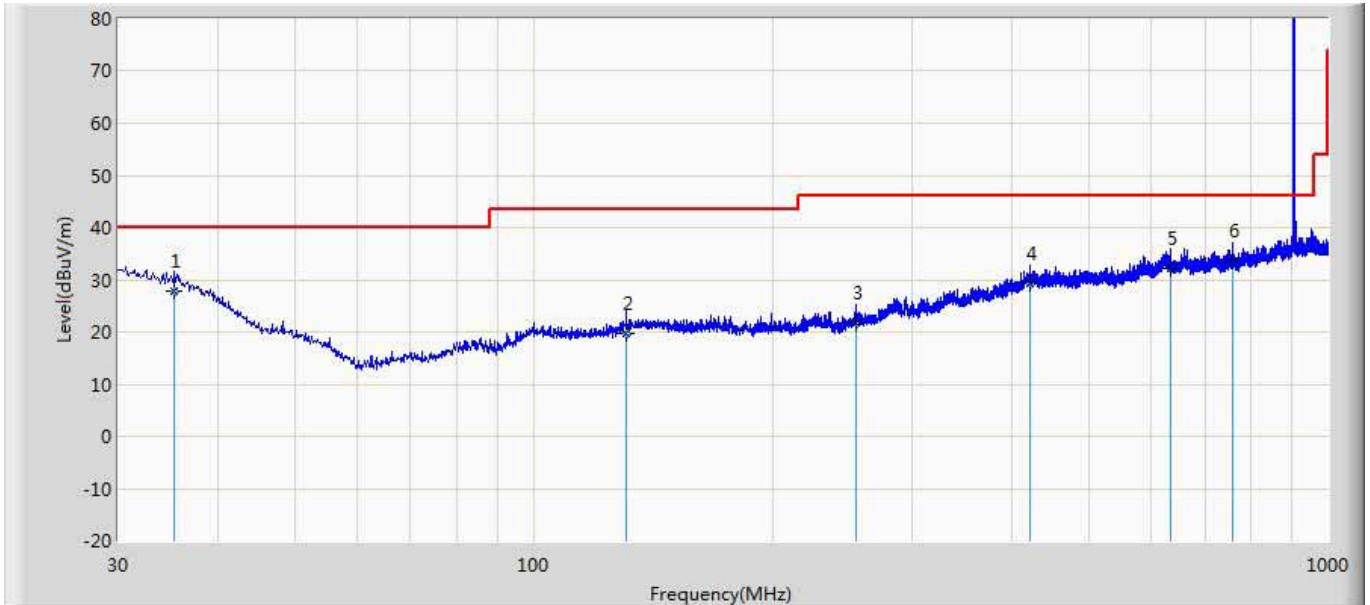

No	Mark	Frequency (MHz)	Measure Level (dBuV/m)	Reading Level (dBuV)	Over Limit (dB)	Limit (dBuV/m)	Probe (dB/m)	Cable (dB)	Amp (dB)	Ant Pos (cm)	Table Pos (deg)	Type
1	*	35.335	27.747	2.100	-12.253	40.000	19.154	6.494	0.000	300	185	QP
2		131.001	19.737	2.400	-23.763	43.500	10.341	6.996	0.000	400	265	QP
3		255.161	21.757	2.800	-24.243	46.000	11.485	7.472	0.000	200	19	QP
4		421.510	29.303	2.100	-16.697	46.000	19.243	7.960	0.000	208	0	QP
5		635.037	32.179	3.400	-13.821	46.000	20.263	8.516	0.000	300	311	QP
6		758.349	33.537	3.900	-12.463	46.000	20.842	8.795	0.000	100	296	QP

Site: AC3	Time: 2017/09/19
Limit: FCC_Part15.209_RE(3m)	Margin: 0
Probe: AC3_3m (30-1000MHz)	Polarity: Vertical
EUT: Push Button	Power: AC 120V/60Hz
Note: Mode 1:Transmit at channel 902.3MHz	

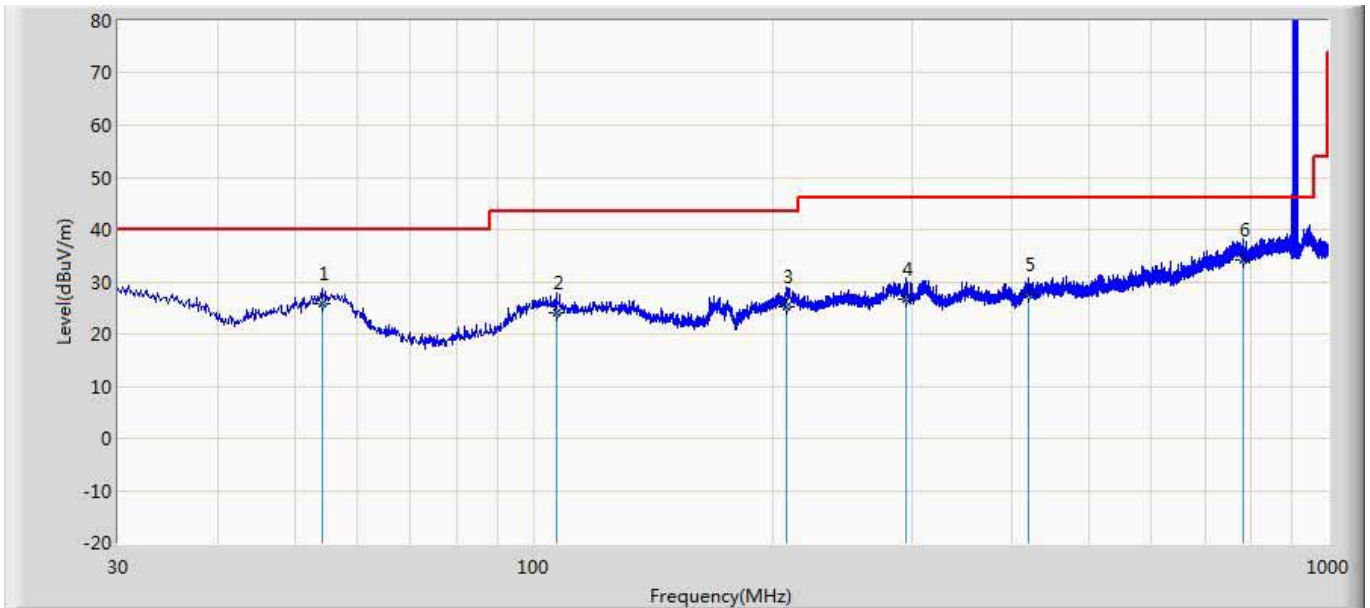

No	Mark	Frequency (MHz)	Measure Level (dBuV/m)	Reading Level (dBuV)	Over Limit (dB)	Limit (dBuV/m)	Probe (dB/m)	Cable (dB)	Amp (dB)	Ant Pos (cm)	Table Pos (deg)	Type
1		54.129	25.756	8.600	-14.244	40.000	10.537	6.619	0.000	100	322	QP
2		106.751	24.014	2.200	-19.486	43.500	14.928	6.886	0.000	100	283	QP
3		208.359	25.188	1.900	-18.312	43.500	15.975	7.313	0.000	100	101	QP
4		294.689	26.771	2.800	-19.229	46.000	16.366	7.605	0.000	100	322	QP
5		420.304	27.665	2.200	-18.335	46.000	17.505	7.960	0.000	300	53	QP
6	*	781.144	34.168	2.500	-11.832	46.000	22.828	8.839	0.000	298	0	QP

5. 20dB Bandwidth

5.1 Test Equipment

20dB Occupied Bandwidth / TR-8					
Instrument	Manufacturer	Type No.	Serial No.	Cal. Date	Cal. Due Date
Spectrum Analyzer	Agilent	N9010A	MY48030494	2017.02.04	2018.02.03
EXA Spectrum Analyzer	Keysight	N9010A	MY55370495	2017.04.09	2018.04.08
MXA Signal Analyzer	Keysight	N9020A	MY56060147	2017.04.09	2018.04.08
Temperature/Humidity Meter	zhichen	ZC1-2	TR8-TH	2017.04.10	2018.04.09

Note: All equipments are calibrated with traceable calibrations. Each calibration is traceable to the national or international standards.

5.2 Test Setup

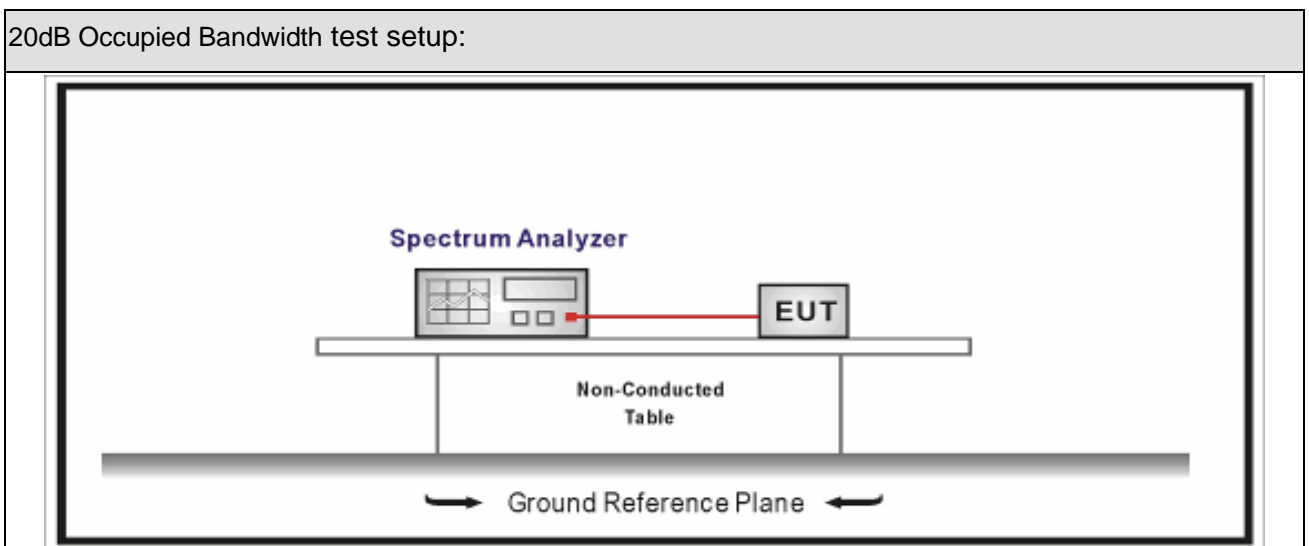

5.3 Limit

Carrier Frequency Separation	
<input type="checkbox"/>	For frequency hopping systems operating in 2400-2483.5 MHz band, within frequency range.
<input checked="" type="checkbox"/>	For frequency hopping systems operating in 902-928 MHz band, the maximum allowed 20 dB bandwidth of the hopping channel is 500 kHz.
<input type="checkbox"/>	For frequency hopping systems operating in 5725-5850 MHz band, the maximum 20 dB bandwidth of the hopping channel is 1 MHz.

5.4 Test Procedure

Test Method			
	References Rule	Chapter	Description
<input checked="" type="checkbox"/>	DA 00-705	N/A	20 dB Bandwidth

5.5 Uncertainty

The measurement uncertainty is defined as ± 1 kHz

5.6 Test Result

Product Name	: Push Button	Power	: AC 120V/60Hz
Test Mode	: Mode 1	Test Site	: TR-8
Test Date	: 2017.10.26		

Channel No.	Frequency (MHz)	20dB Bandwidth (kHz)	99% Bandwidth (kHz)
00	902.3	165.3	143.20
31	908.5	162.2	143.15
63	914.9	165.8	143.63

Channel 00 (902.3MHz)

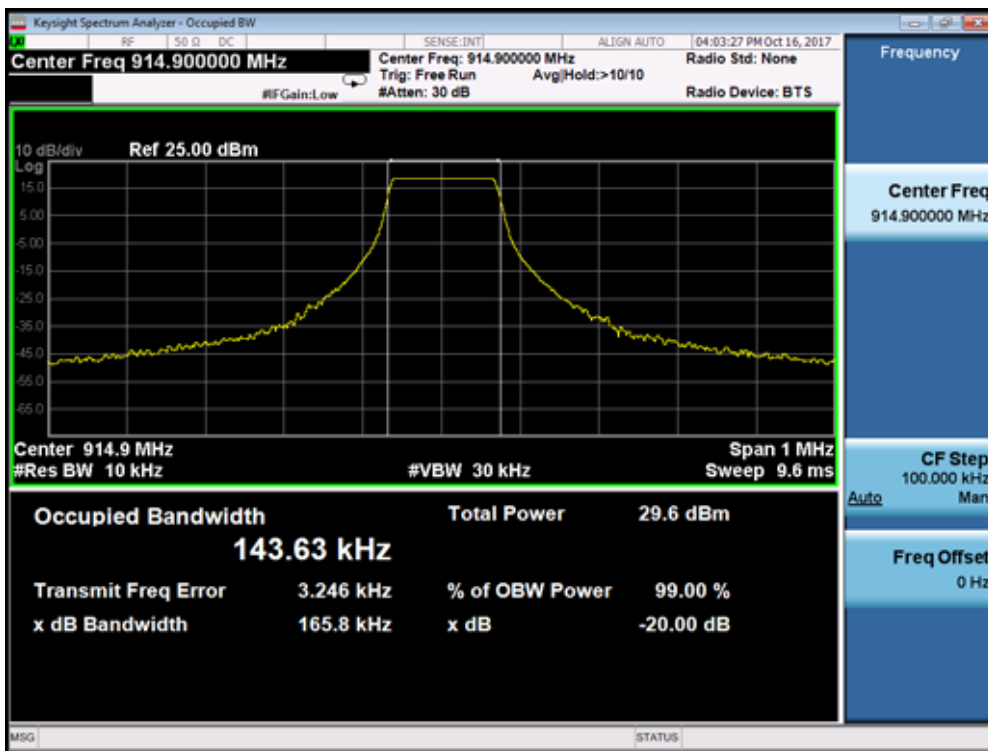

Channel 31 (908.5MHz)

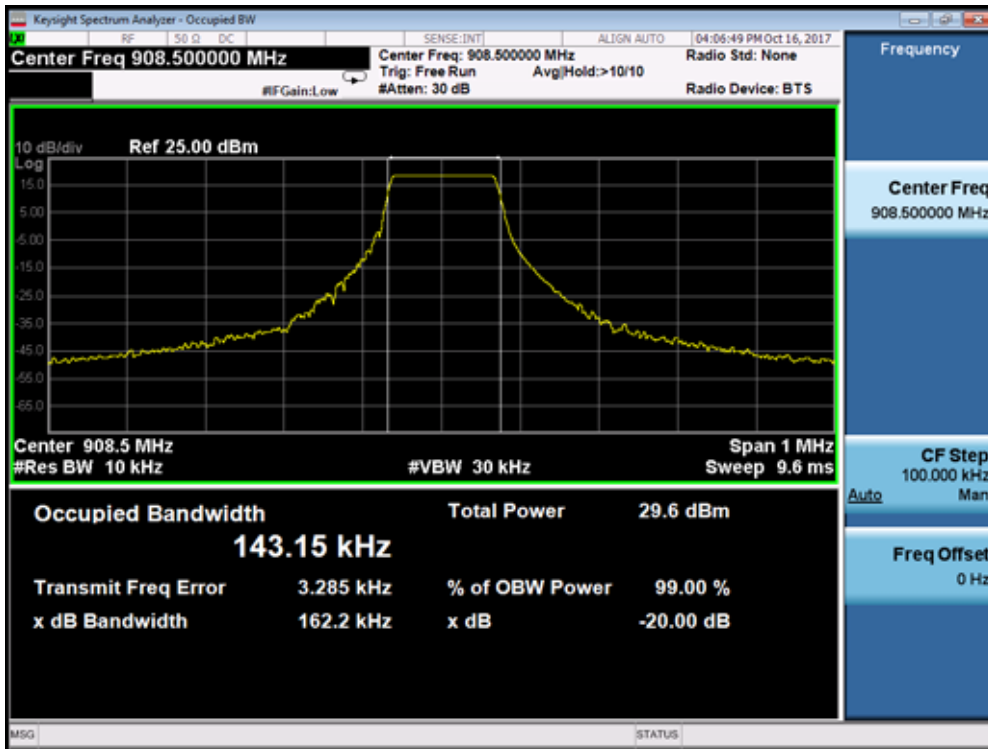

Channel 63 (914.9MHz)

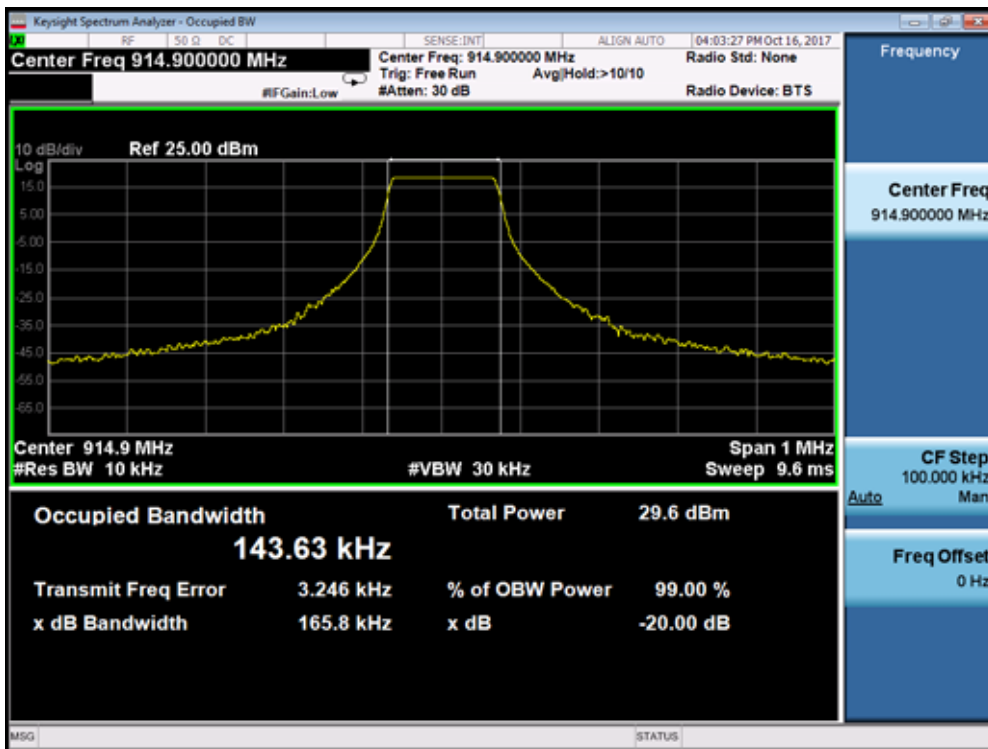

6. Carrier Frequency Separation

6.1. Test Equipment

Carrier Frequency Separation / TR-8					
Instrument	Manufacturer	Type No.	Serial No.	Cal. Date	Cal. Due Date
Spectrum Analyzer	Agilent	N9010A	MY48030494	2017.02.04	2018.02.03
EXA Spectrum Analyzer	Keysight	N9010A	MY55370495	2017.04.09	2018.04.08
MXA Signal Analyzer	Keysight	N9020A	MY56060147	2017.04.09	2018.04.08
Temperature/Humidity Meter	zhichen	ZC1-2	TR8-TH	2017.04.10	2018.04.09

Note: All equipments are calibrated with traceable calibrations. Each calibration is traceable to the national or international standards.

6.2. Test Setup

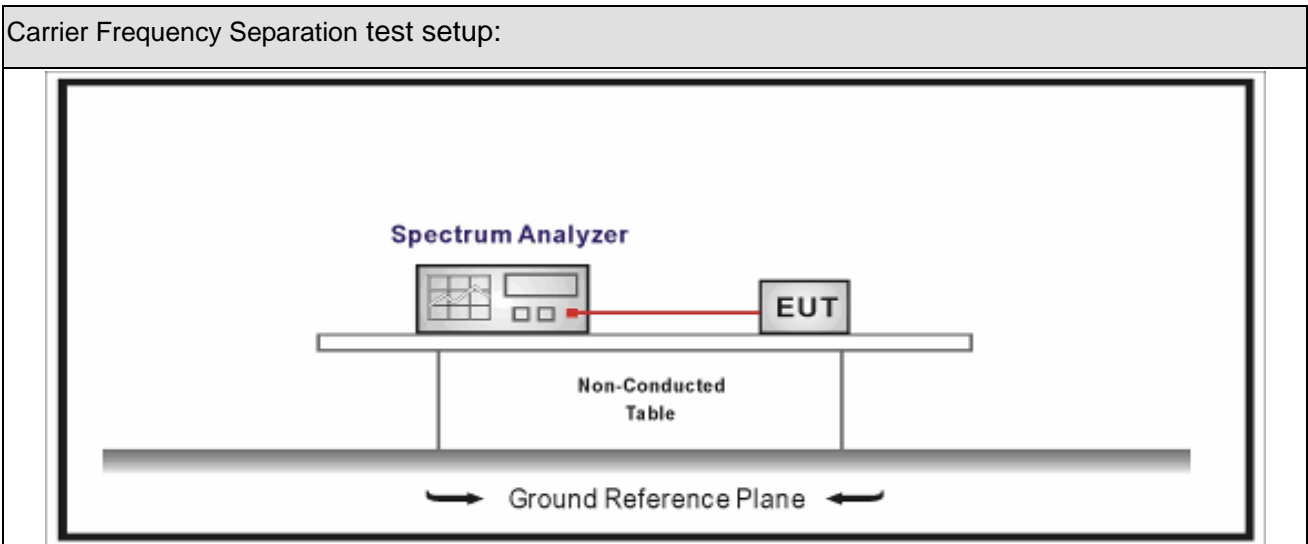

6.3. Limit

Carrier Frequency Separation	
<input checked="" type="checkbox"/>	Frequency hopping systems shall have hopping channel carrier frequencies separated by a minimum of 25 kHz or the 20 dB bandwidth of the hopping channel, whichever is greater.
<input type="checkbox"/>	Frequency hopping systems operating in the 2400-2483.5 MHz band may have hopping channel carrier frequencies that are separated by 25 kHz or two-thirds of the 20 dB bandwidth of the hopping channel.
<input type="checkbox"/>	The 20 dB bandwidth of the hopping channel is less than 250 kHz, the system shall use at least 50 hopping frequencies and the average time of occupancy on any frequency shall not be greater than 0.4 seconds within a 20 second period;
<input type="checkbox"/>	The 20 dB bandwidth of the hopping channel is 250 kHz or greater, the system shall use at least 25 hopping frequencies and the average time of occupancy on any frequency shall not be greater than 0.4 seconds within a 10 second period. The maximum allowed 20 dB bandwidth of the hopping channel is 500 kHz.
<input type="checkbox"/>	Frequency hopping systems operating in the 5725-5850 MHz band shall use at least 75 hopping frequencies. The maximum 20 dB bandwidth of the hopping channel is 1 MHz.

6.4. Test Procedure

Test Method			
	References Rule	Chapter	Description
<input checked="" type="checkbox"/>	ANSI C63.10	7.8.2	Carrier frequency separation

6.5. Uncertainty

The measurement uncertainty is defined as ± 1 kHz

6.6. Test Result

Product Name	: Push Button	Power	: AC 120V/60Hz
Test Mode	: Mode 1	Test Site	: TR-8
Test Date	: 2017.10.16		

Channel No.	Frequency (MHz)	Carrier Frequency Separation (kHz)	Limit (kHz)	Result
00	902.3	200	165.3	Pass
31	908.5	200	162.2	Pass
63	914.9	200	165.8	Pass

Channel 00 (902.3MHz)

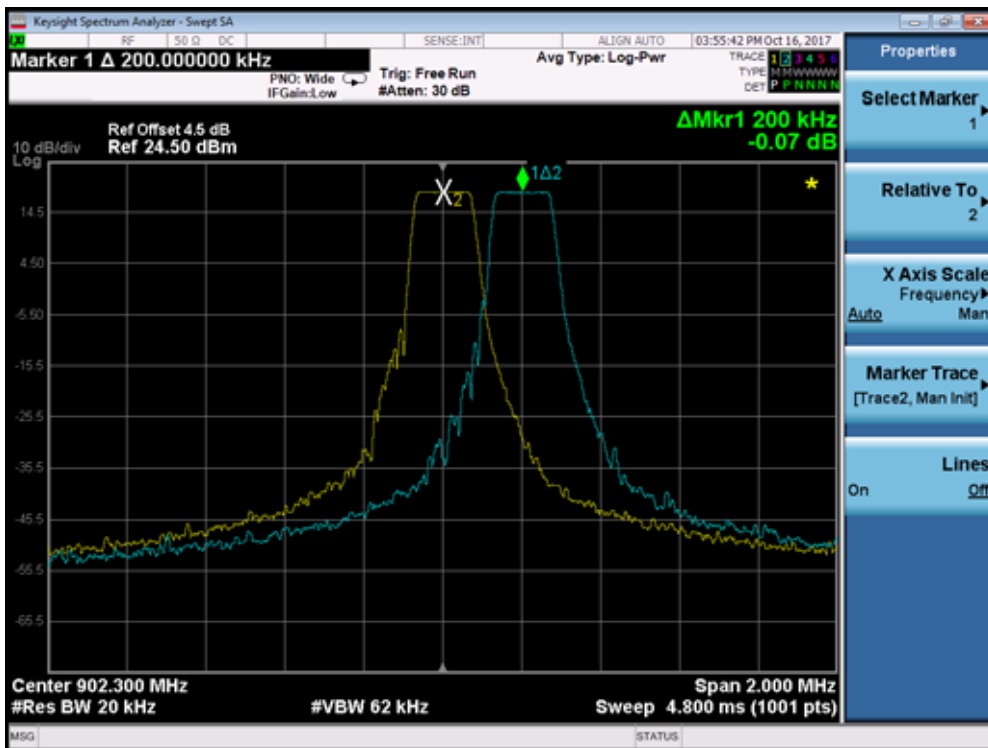

Channel 31 (908.5MHz)

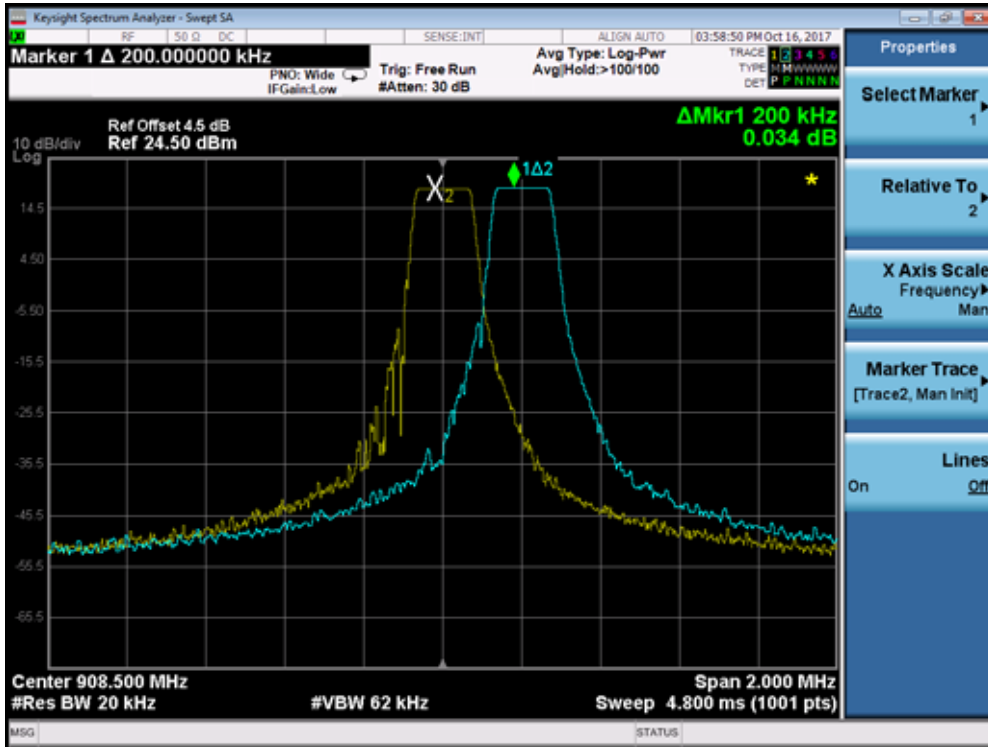

Channel 63 (914.9MHz)

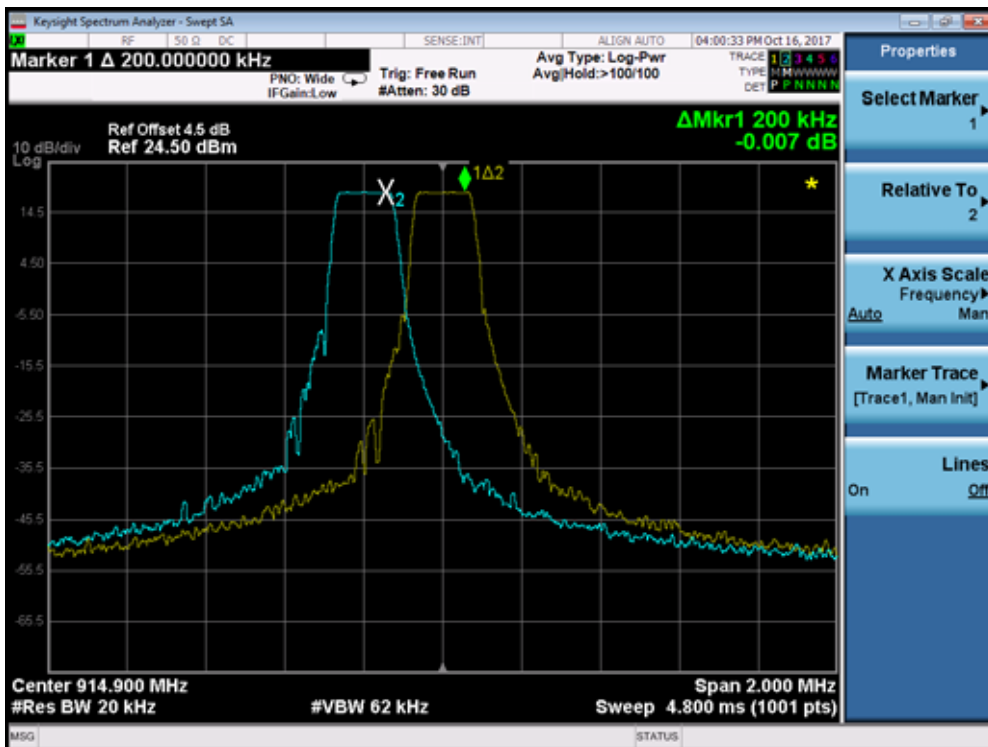

7. Number of Hopping Frequencies

7.1. Test Equipment

Number of Hopping Frequencies / TR-8					
Instrument	Manufacturer	Type No.	Serial No.	Cal. Date	Cal. Due Date
Spectrum Analyzer	Agilent	N9010A	MY48030494	2017.02.04	2018.02.03
EXA Spectrum Analyzer	Keysight	N9010A	MY55370495	2017.04.09	2018.04.08
MXA Signal Analyzer	Keysight	N9020A	MY56060147	2017.04.09	2018.04.08
Temperature/Humidity Meter	zhichen	ZC1-2	TR8-TH	2017.04.10	2018.04.09

Note: All equipments are calibrated with traceable calibrations. Each calibration is traceable to the national or international standards.

7.2. Test Setup

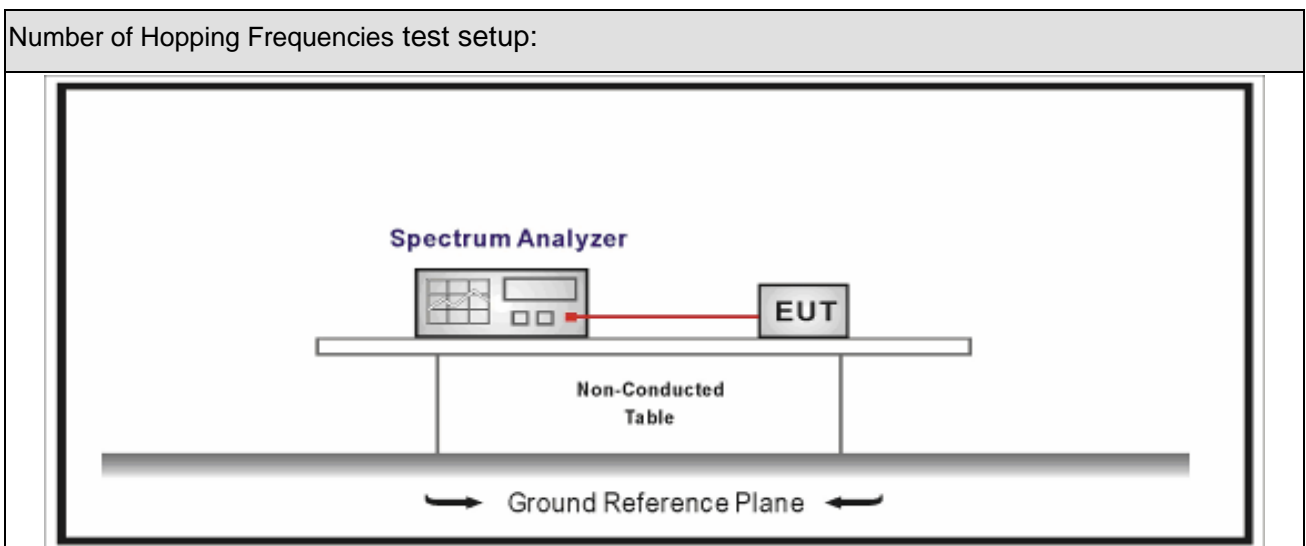

7.3. Limit

Carrier Frequency Separation	
<input type="checkbox"/>	For frequency hopping systems operating in the 2400-2483.5 MHz band shall use at least 15 hopping frequencies.
<input checked="" type="checkbox"/>	For frequency hopping systems operating in 902-928 MHz band, if the 20 dB bandwidth of the hopping channel is less than 250 kHz, shall use at least 50 hopping frequencies.
<input type="checkbox"/>	For frequency hopping systems operating in 902-928 MHz band, if the 20 dB bandwidth of the hopping channel is higher than 250 kHz, shall use at least 25 hopping frequencies.
<input type="checkbox"/>	For frequency hopping systems operating in the 5725-5850 MHz band shall use at least 75 hopping frequencies.

7.4. Test Procedure

Test Method			
	References Rule	Chapter	Description
<input checked="" type="checkbox"/>	ANSI C63.10	7.8.3	Number of Hopping Frequencies

7.5. Uncertainty

The measurement uncertainty is defined as ± 1 kHz

7.6. Test Result

Product Name	: Push Button	Power	: AC 120V/60Hz
Test Mode	: Mode 1	Test Site	: TR-8
Test Date	: 2017.10.16		

Frequency Band (MHz)	Number of Hopping Frequencies	Limit	Result
902 - 928	64	>50	Pass

902 - 928MHz

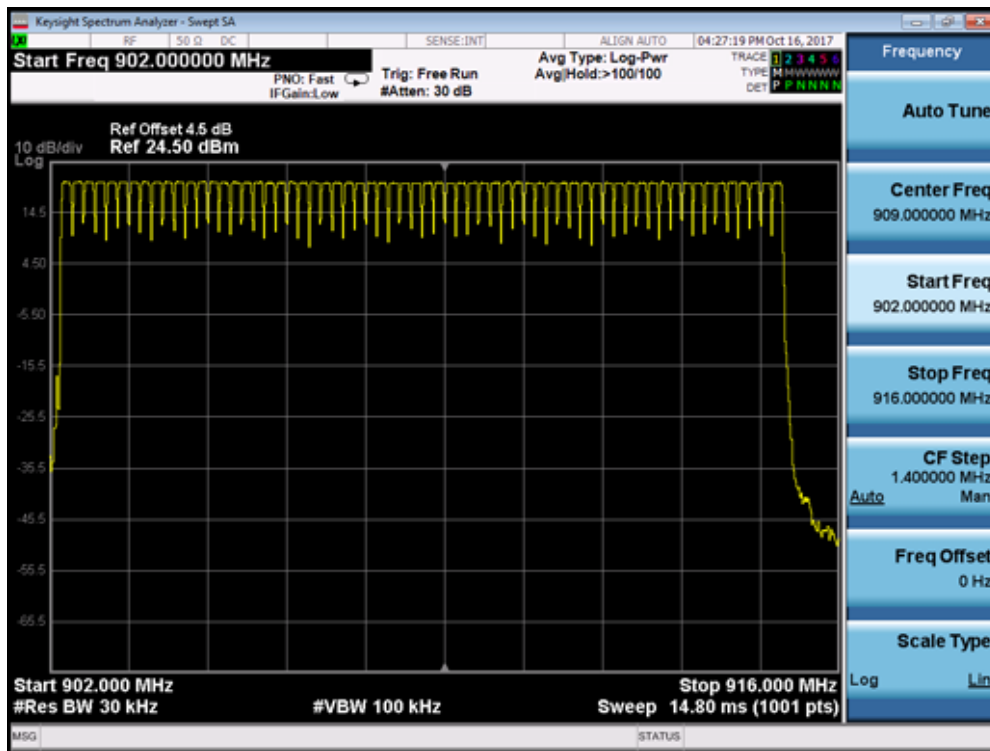

8. Time of Occupancy (Dwell Time)

8.1. Test Equipment

Time of Occupancy (Dwell Time) / TR-8					
Instrument	Manufacturer	Type No.	Serial No.	Cal. Date	Cal. Due Date
Spectrum Analyzer	Agilent	N9010A	MY48030494	2017.02.04	2018.02.03
EXA Spectrum Analyzer	Keysight	N9010A	MY55370495	2017.04.09	2018.04.08
MXA Signal Analyzer	Keysight	N9020A	MY56060147	2017.04.09	2018.04.08
Temperature/Humidity Meter	zhichen	ZC1-2	TR8-TH	2017.04.10	2018.04.09

Note: All equipments are calibrated with traceable calibrations. Each calibration is traceable to the national or international standards.

8.2. Test Setup

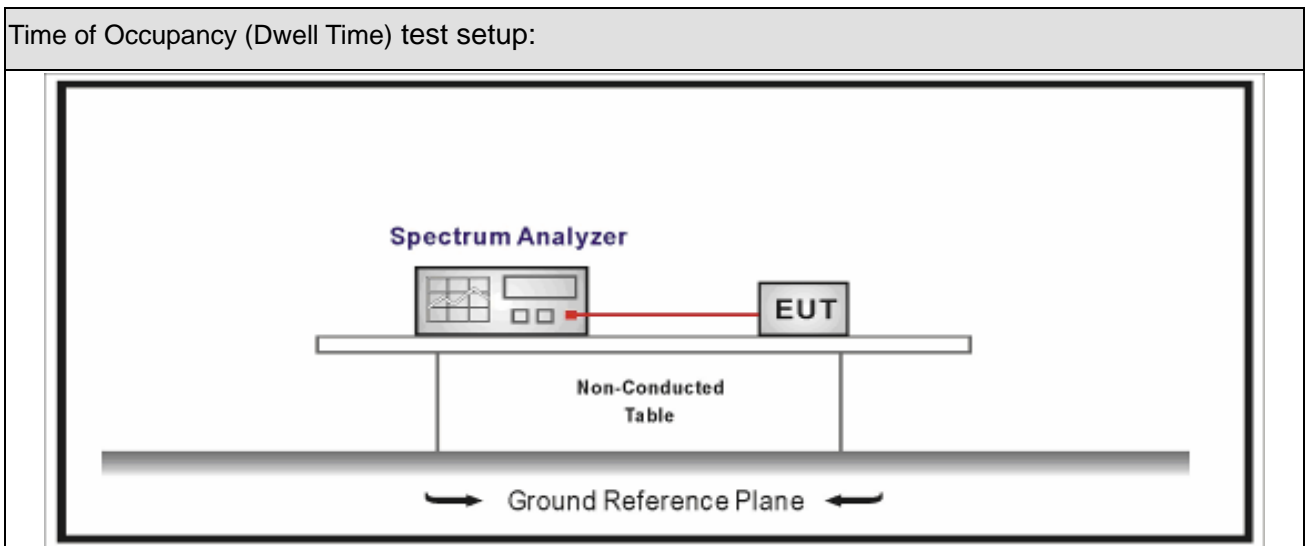

8.3. Limit

Time of Occupancy (Dwell Time)	
<input type="checkbox"/>	Frequency hopping systems in the 2400-2483.5 MHz band shall use at least 15 channels. The average time of occupancy on any channel shall not be greater than 0.4 seconds within a period of 0.4 seconds multiplied by the number of hopping channels employed.
<input checked="" type="checkbox"/>	For frequency hopping systems operating in the 902-928 MHz band: if the 20 dB bandwidth of the hopping channel is less than 250 kHz, the system shall use at least 50 hopping frequencies and the average time of occupancy on any frequency shall not be greater than 0.4 seconds within a 20 second period
<input type="checkbox"/>	For frequency hopping systems operating in the 902-928 MHz band: if the 20 dB bandwidth of the hopping channel is 250 kHz or greater, the system shall use at least 25 hopping

	frequencies and the average time of occupancy on any frequency shall not be greater than 0.4 seconds within a 10 second period.
<input type="checkbox"/>	Frequency hopping systems operating in the 5725-5850 MHz band shall use at least 75 hopping frequencies. The maximum 20 dB bandwidth of the hopping channel is 1 MHz. The average time of occupancy on any frequency shall not be greater than 0.4 seconds within a 30 second period.

8.4. Test Procedure

Test Method			
	References Rule	Chapter	Description
<input checked="" type="checkbox"/>	ANSI C63.10	7.8.4	Time of Occupancy (Dwell Time)

8.5. Uncertainty

The measurement uncertainty is defined as $\pm 0.1 \text{ us}$

8.6. Test Result

Product Name	: Push Button	Power	: AC 120V/60Hz
Test Mode	: Mode 1	Test Site	: TR-8
Test Date	: 2017.10.16		

Channel No.	Frequency (MHz)	Time of Occupancy (ms)	Limit (ms)	Result
31	902.3	278.64	< 400	Pass

Channel 31 (902.3MHz)

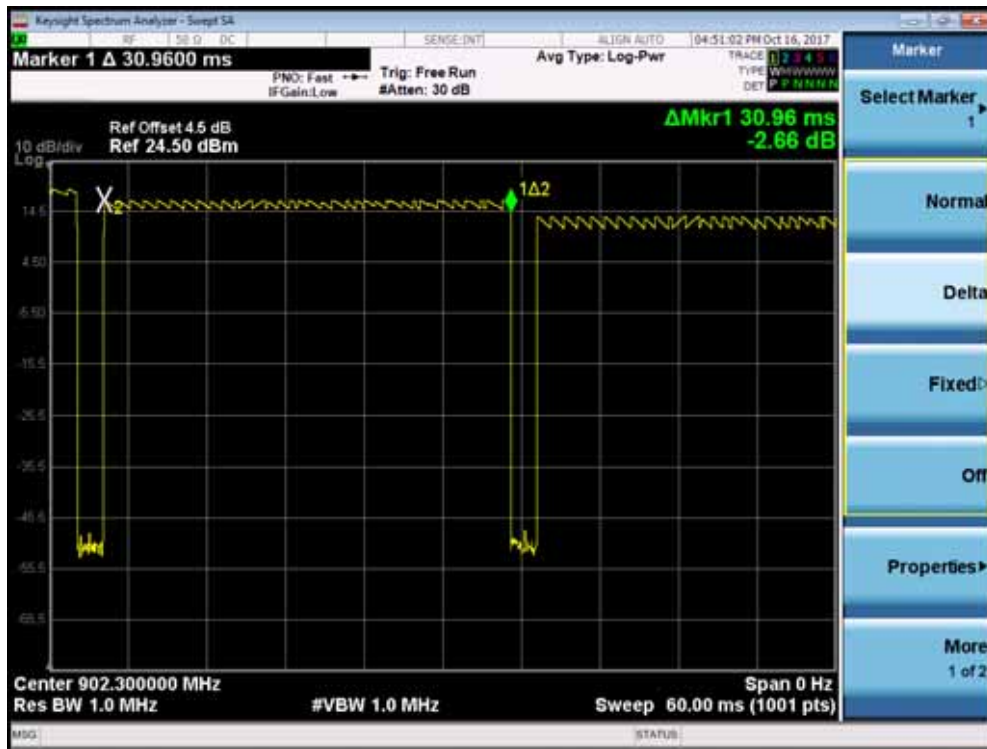

Note: Dwell time with the configuration of maximum number of hopping channels.

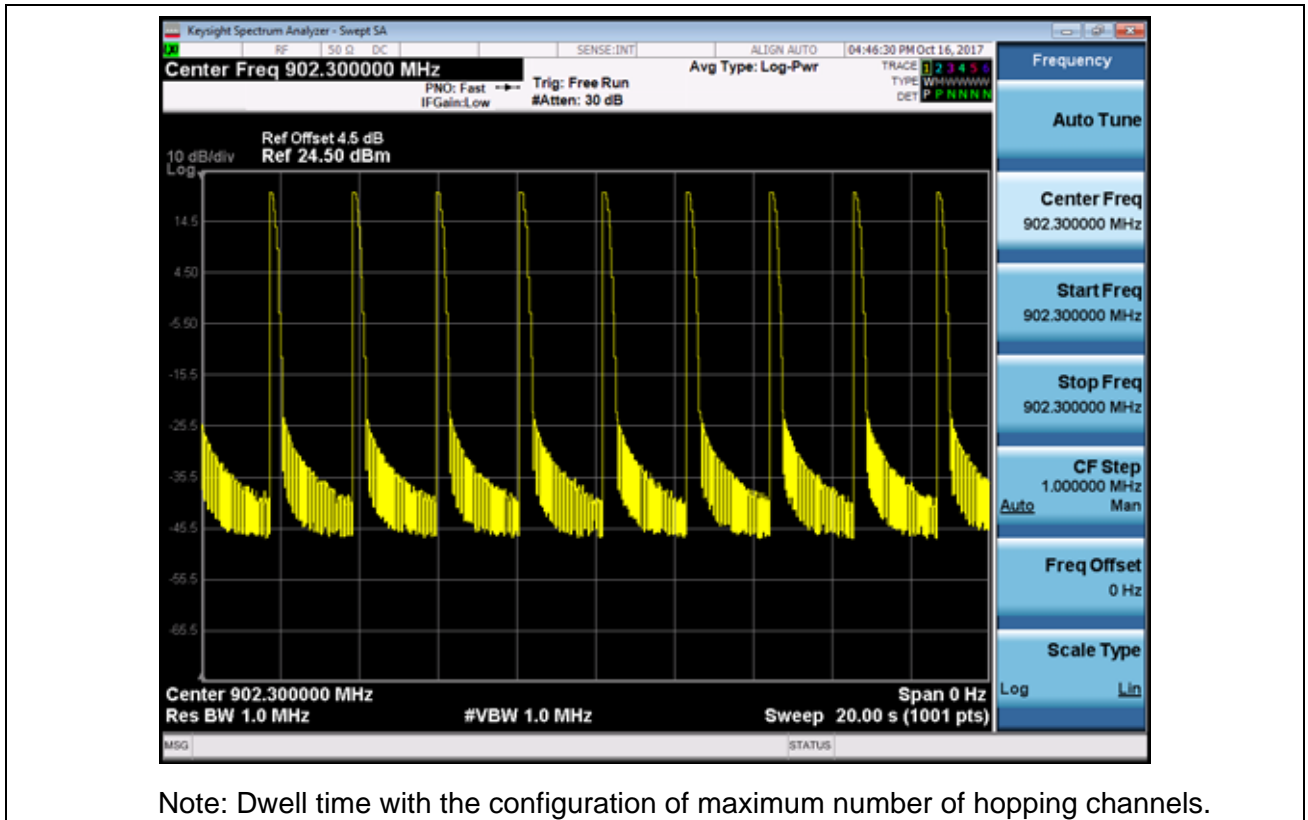

Channel No.	Frequency (MHz)	Time of Occupancy (ms)	Limit (ms)	Result
00	902.3	370.4	< 400	Pass

Channel 00 (902.3MHz)

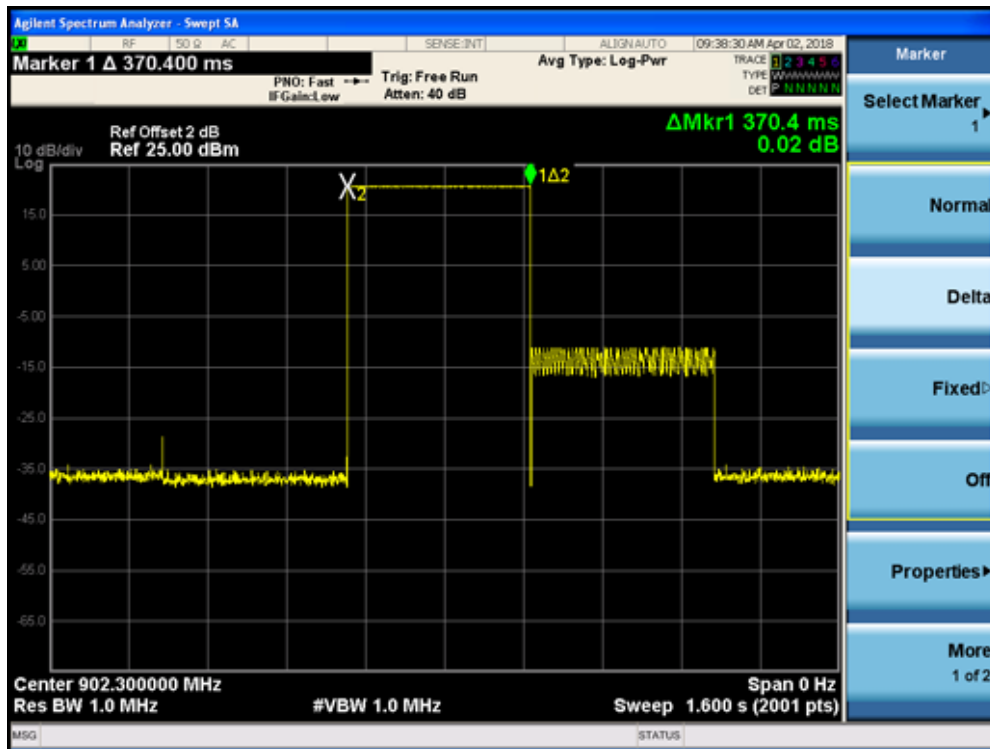

Note: Dwell time with the configuration of minimum number of hopping channels.

9. Peak Output Power

9.1. Test Equipment

Peak Output Power / TR-8					
Instrument	Manufacturer	Type No.	Serial No.	Cal. Date	Cal. Due Date
Spectrum Analyzer	Agilent	N9010A	MY48030494	2017.02.04	2018.02.03
EXA Spectrum Analyzer	Keysight	N9010A	MY55370495	2017.04.09	2018.04.08
MXA Signal Analyzer	Keysight	N9020A	MY56060147	2017.04.09	2018.04.08
Temperature/Humidity Meter	zhichen	ZC1-2	TR8-TH	2017.04.10	2018.04.09

Note: All equipments are calibrated with traceable calibrations. Each calibration is traceable to the national or international standards.

9.2. Test Setup

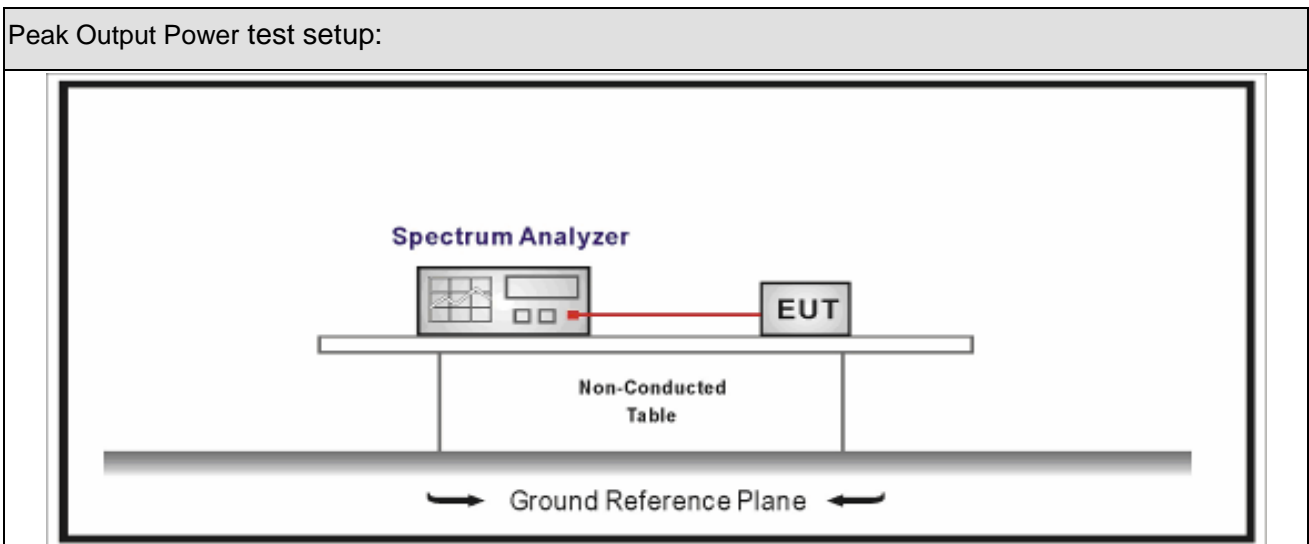

9.3. Limit

Peak Output Power	
<input type="checkbox"/>	Frequency hopping systems operating in the 2400-2483.5 MHz band employing at least 75 non-overlapping hopping channels, and all frequency hopping systems in the 5725-5850 MHz band: 1 watt. For all other frequency hopping systems in the 2400-2483.5 MHz band: 0.125 watts.
<input type="checkbox"/>	Frequency hopping systems operating in the 2400-2483.5 MHz band may have hopping channel carrier frequencies that are separated by 25 kHz or two-thirds of the 20 dB bandwidth of the hopping channel, whichever is greater, provided the systems operate with an output power no greater than 125 mW.
<input checked="" type="checkbox"/>	For frequency hopping systems operating in the 902-928 MHz band: 1 watt for systems employing at least 50 hopping channels; and, 0.25 watts for systems employing less than 50 hopping channels, but at least 25 hopping channels

9.4. Test Procedure

Test Method			
	References Rule	Chapter	Description
<input checked="" type="checkbox"/>	ANSI C63.10	7.8.5	Output power test procedure for frequency-hopping spread-spectrum (FHSS) devices

9.5. Uncertainty

The measurement uncertainty is defined as ± 1.0 dB

9.6. Test Result

Product Name	:	Push Button	Power	:	AC 120V/60Hz
Test Mode	:	Mode 1	Test Site	:	TR-8
Test Date	:	2017.10.29			

Channel No.	Frequency (MHz)	Measurement Power Output (dBm)	Limit (dBm)	Result
00	902.3	20.36	30.00	Pass
31	908.5	20.41	30.00	Pass
63	914.9	20.27	30.00	Pass

10. Emissions in non-restricted frequency bands

10.1. Test Equipment

Emissions in non-restricted frequency bands / TR-8					
Instrument	Manufacturer	Type No.	Serial No.	Cal. Date	Cal. Due Date
Spectrum Analyzer	Agilent	N9010A	MY48030494	2017.02.04	2018.02.03
EXA Spectrum Analyzer	Keysight	N9010A	MY55370495	2017.04.09	2018.04.08
MXA Signal Analyzer	Keysight	N9020A	MY56060147	2017.04.09	2018.04.08
Temperature/Humidity Meter	zhichen	ZC1-2	TR8-TH	2017.04.10	2018.04.09

Note: All equipments are calibrated with traceable calibrations. Each calibration is traceable to the national or international standards.

10.2. Test Setup

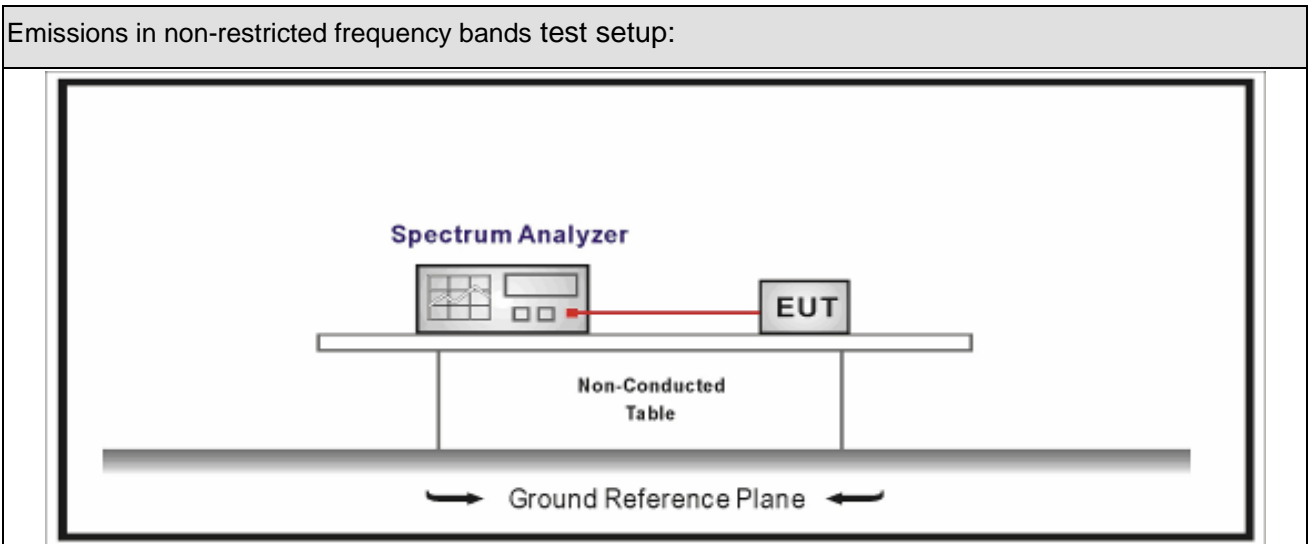

10.3. Limit

Un-Restricted Band Emissions Limit	
RF Output power (Detection methods)	Limit(dB)
RF Output power(Average detector)	30c(Note1)
RF Output power(PK detector)	20c(Note2)
<p>Note 1: If maximum conducted (average) output power was used to demonstrate compliance as described in 9.2, then the peak power in any 100 kHz bandwidth outside of the authorized frequency band shall be attenuated by at least 30 dB relative to the maximum in-band peak PSD level in 100 kHz (i.e., 30 dBc).</p> <p>Note 2: If the maximum peak conducted output power procedure was used, then the peak output power measured in any 100 kHz bandwidth outside of the authorized frequency band shall be attenuated by at least 20 dB relative to the maximum in-band peak PSD level in 100 kHz (i.e., 20 dBc).</p>	

10.4. Test Procedure

Test Method			
	References Rule	Chapter	Description
<input checked="" type="checkbox"/>	ANSI C63.10	7.8.6	Band-edge Compliance of RF Conducted Emissions

10.5. Uncertainty

The measurement uncertainty is defined as ± 1.0 dB

10.6. Test Result

Product Name	: Push Button	Power	: AC 120V/60Hz
Test Mode	: Mode 1	Test Site	: TR-8
Test Date	: 2017.10.06		

Mode	Channel	Test Frequency (MHz)	In-Band PSD[a] (dBm/100kHz)	Frequency (MHz)	Out-Band PSD[b] (dBm/100kHz)	[a]-[b] (dB)	Limit (dB)	Result
1	00	902.3	20.560	918.9	-49.544	70.104	>20	Pass
1	63	914.9	20.891	930.0	-48.861	69.752	>20	Pass
1	00~63	00~63	20.302	-44.43	-52.260	72.562	>20	Pass

Note1: The worst case of Emissions in non-restricted frequency bands as below:

Mode 1 CH63(914.9MHz)

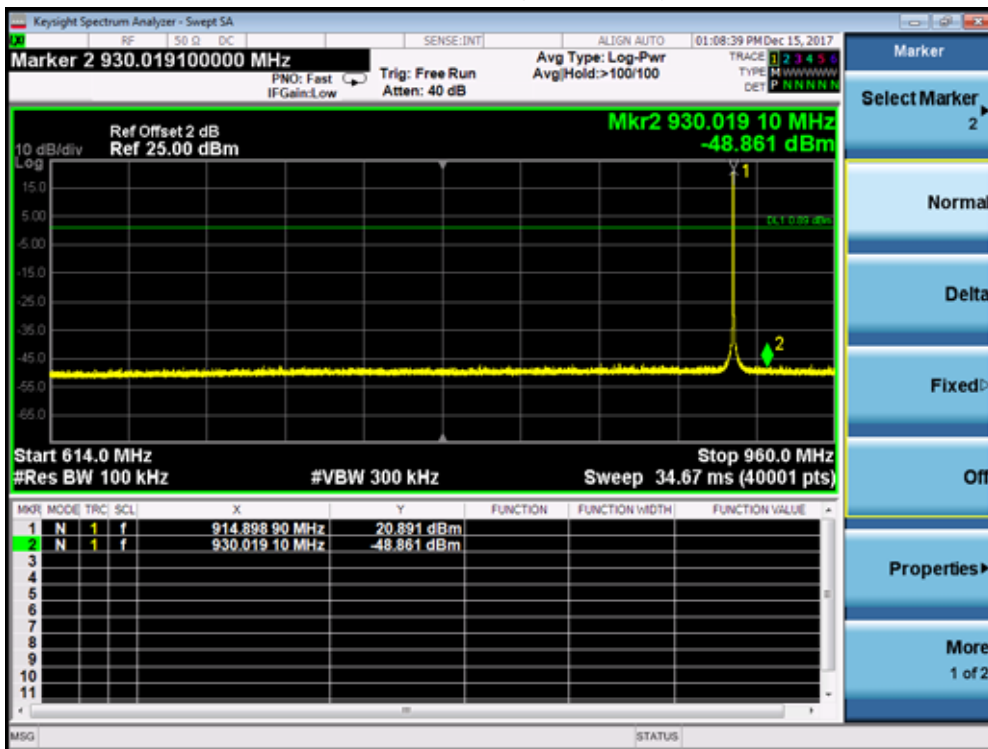

11. Radiated Emission Band Edge

11.1. Test Equipment

Radiated Emission(Above 1GHz) / AC-5					
Instrument	Manufacturer	Type No.	Serial No.	Cal. Date	Cal. Due Date
EMI Receiver	Agilent	N9038A	MY51210196	2017.07.16	2018.07.15
Pre-Amplifier	Miteq	NSP1800-25	1364185	2017.05.03	2018.05.02
DRG Horn Antenna	ETS-Lindgren	3117	00167055	2017.07.12	2018.07.11
Broad-Band Horn Antenna	Schwarzbeck	BBHA9170	294	2017.09.18	2018.09.17
Coaxial Cable	Huber+Suhner	SUCOFLEX 106	AC5-C1	2017.02.28	2018.02.27
Coaxial Cable	Huber+Suhner	SUCOFLEX 106	AC5-C2	2017.02.28	2018.02.27
Temperature/Humidity Meter	Zhichen	ZC1-2	AC5-TH	2017.01.05	2018.01.04

11.2. Test Setup

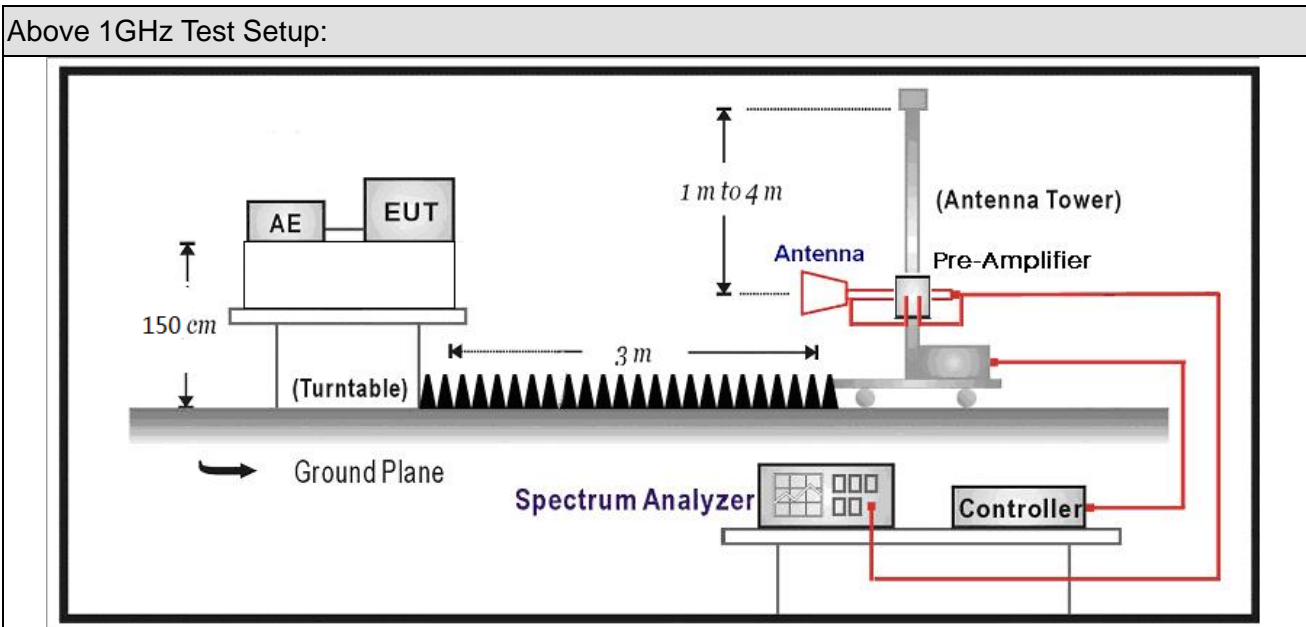

11.3. Limit

Band edge Limit				
Frequency bands (MHz)	Detector	Limit (dB μ V/m)	RBW (KHz)	Distance (m)
608-614	PK	74	100	3
960-1240	AV	54	300	3

Note: The field strength of emissions appearing within these frequency bands shall not exceed the limits.

11.4. Test Procedure

Test Method			
	References Rule	Chapter	Description
<input checked="" type="checkbox"/>	DA 00-705	N/A	duty cycle correction factor
<input checked="" type="checkbox"/>	ANSI C63.10	6.10	Band-edge testing
	<input checked="" type="checkbox"/> ANSI C63.10	6.10.5	Restricted-band band-edge measurements
	<input type="checkbox"/> ANSI C63.10	6.10.6	Marker-delta method
<input type="checkbox"/>	ANSI C63.10	6.4	Radiated emissions from unlicensed wireless devices below 30 MHz
<input type="checkbox"/>	ANSI C63.10	6.5	Radiated emissions from unlicensed wireless devices in the frequency range of 30 MHz to 1000 MHz
<input checked="" type="checkbox"/>	ANSI C63.10	6.6	Radiated emissions from unlicensed wireless devices above 1 GHz

11.5. Uncertainty

The measurement uncertainty above 1G is defined as ± 3.9 dB
 below 1G is defined as ± 3.8 dB

11.6. Test Result

No restricted band in the range ± 2 channel bandwidths of the Band-edges of the specified emission band! (608 MHz – 614 MHz and 960 MHz – 1240 MHz).

12. Power Spectral Density

12.1. Test Equipment

Power Spectral Density / TR-8					
Instrument	Manufacturer	Type No.	Serial No.	Cal. Date	Cal. Due Date
Spectrum Analyzer	Agilent	N9010A	MY48030494	2018.02.04	2019.02.03
EXA Spectrum Analyzer	Keysight	N9010A	MY55370495	2017.04.09	2018.04.08
MXA Signal Analyzer	Keysight	N9020A	MY56060147	2017.04.09	2018.04.08
Temperature/Humidity Meter	zhichen	ZC1-2	TR8-TH	2017.04.10	2018.04.09

Note: All equipment are calibrated with traceable calibrations. Each calibration is traceable to the national or international standards.

12.2. Test Setup

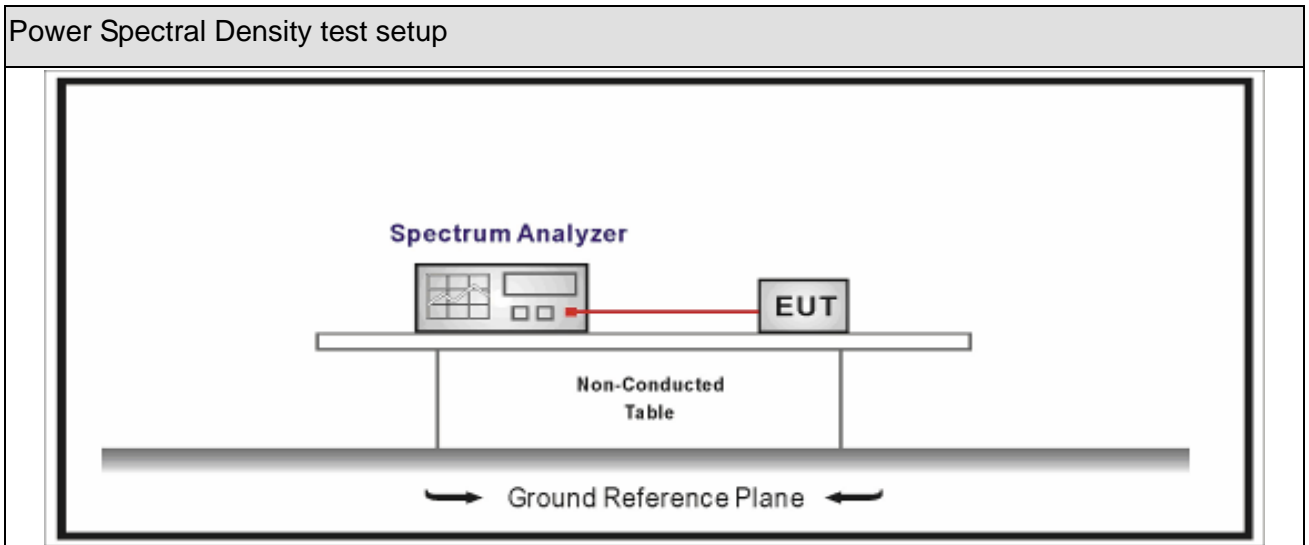



12.3. Limit

Power Spectral Density Limit
Power Spectral Density 8dBm/3kHz

12.4. Test Procedure

Power Spectral Density Test Method			
	References Rule	Chapter	Description
<input checked="" type="checkbox"/>	ANSI C63.10	11.10	Maximum power spectral density level in the fundamental emission
<input type="checkbox"/>	ANSI C63.10	11.10.2	Method PKPSD (peak PSD)
<input checked="" type="checkbox"/>	ANSI C63.10	11.10.3	Method AVGPSD-1(Duty cycle 98%)
<input type="checkbox"/>	ANSI C63.10	11.10.4	Method AVGPSD-1A(Duty cycle 98%)
<input type="checkbox"/>	ANSI C63.10	11.10.5	Method AVGPSD-2(Duty cycle < 98%)
<input type="checkbox"/>	ANSI C63.10	11.10.6	Method AVGPSD-2A(Duty cycle < 98%)
<input type="checkbox"/>	ANSI C63.10	11.10.7	Method AVGPSD-3
<input type="checkbox"/>	ANSI C63.10	11.10.8	Method AVGPSD-3A

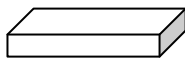
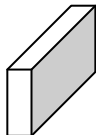
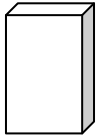
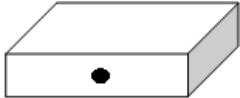
12.5. EUT test definition

Item	Power Spectral Density Test Method			
Device Category	<input type="checkbox"/>	Fixed position use		
	<input checked="" type="checkbox"/>	Mobile position use		
Test mode	Mode 1			
Test method	<input type="checkbox"/>	Radiated		
		X Axis	Y Axis	Z Axis
				
		Worst Axis <input type="checkbox"/>	Worst Axis <input type="checkbox"/>	Worst Axis <input type="checkbox"/>
	<input checked="" type="checkbox"/>	Conducted		
	<input checked="" type="checkbox"/>	Chain 0		
				
	<input type="checkbox"/>	Chain 0	Chain 1	
				
	<input type="checkbox"/>	Chain 0	Chain 1	Chain 2
				

12.6. Test Result

Product Name	: Object Locator	Power	: AC 120V/60Hz
Test Mode	: Mode1	Test Site	: TR8
Test Date	: 2018.04.02		

Mode	Channel	Test Frequency (MHz)	Measurement PSD (dBm/3kHz)	Antenna Gain (dBi)	Limit (dBm/3kHz)	Result
1	00	902.3	7.71	-1.69	8.0	Pass
1	31	908.5	7.74	-1.69	8.0	Pass
1	63	914.9	7.30	-1.69	8.0	Pass

Channel 31 (908.5MHz)



13. Antenna Requirement

12.1. Limit

Antenna Requirement Limit
<p>An intentional radiator shall be designed to ensure that no antenna other than that furnished by the responsible party shall be used with the device. The use of a permanently attached antenna or of an antenna that uses a unique coupling to the intentional radiator shall be considered sufficient to comply with the provisions of this section. The manufacturer may design the unit so that a broken antenna can be replaced by the user, but the use of a standard antenna jack or electrical connector is prohibited. This requirement does not apply to carrier current devices or to devices operated under the provisions of §15.211, §15.213, §15.217, §15.219, or §15.221. Further, this requirement does not apply to intentional radiators that must be professionally installed, such as perimeter protection systems and some field disturbance sensors, or to other intentional radiators which, in accordance with §15.31(d), must be measured at the installation site. However, the installer shall be responsible for ensuring that the proper antenna is employed so that the limits in this part are not exceeded.</p>

12.2. Antenna Connector Construction

Antenna Connector Construction	
<input checked="" type="checkbox"/>	The use of a permanently attached antenna
<input type="checkbox"/>	The antenna use of a unique coupling to the intentional radiator
<input type="checkbox"/>	The use of a nonstandard antenna jack or electrical connector
Please refer to the attached document "Internal Photograph" to show the antenna connector.	

_____ The End _____