Shenzhen Saketron Electronic Technology Co., Ltd.

客 戶:
CUSTOMER: **Shenzhen Yostand Technology Co., Ltd.**

客 戶 料 號:
CUST P/N:

三盛創 料 號:
FINE P/N: **G44-6.8UH Single coil 0.08*24*2*10TS**

產 品 型 號:
DESC: **Φ 43MMX5.3MMX0.5MM**

日 期:
DATE: **2021.10.19**

版 本:
Version: **A.0**

擬制 PREPARED BY	審核 CHECKED BY	批准 APPROVED BY	客戶承認 CUSTOMER APPROVE
Lin suling	An shuaiyin	n shuaiyin	

Adress: No. 9, Yuquan East Road, Yutang Street, Guangming
New District, Shenzhen

SPECIFICATION

產品型號: DESC	Φ 20.5x40-6.8uH-0.08x24*2-15mm	版本 Rev: A.0	客戶 CUST: 客戶料号 CUST P/N:	XXX
---------------	--------------------------------	----------------	----------------------------	------------

一、尺寸 DIMENSION:(mm)

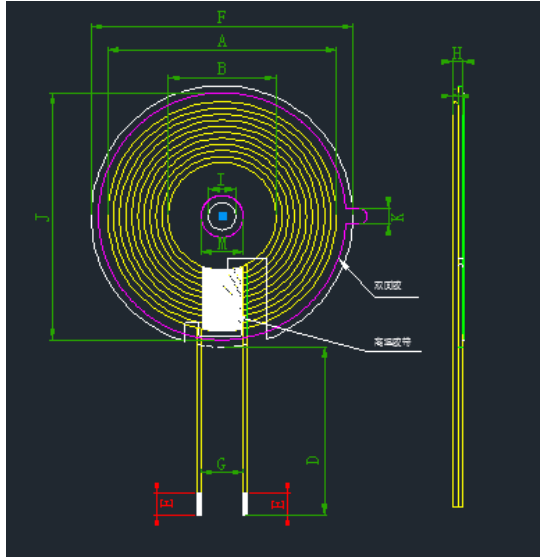

A	41 ± 1.0
B	20.5 ± 0.5
C	1.25
D	15 ± 2
E	3 ± 2
F	43.5 ± 0.5
G	10.0 ± 1
H	1.8
I	5.3 ± 0.5
M	8.0
J	43 ± 1
K	3.0 ± 1

二、原理图 SCHEMATIC DIAGRAM:

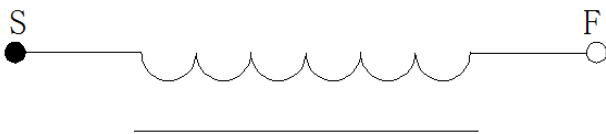

Remark:

1. Cross outgoing line;
2. Wrap 8mm (ref) wide high temperature adhesive tape at the outlet position for 1-2Ts;
3. The coil is pasted with circular hard magnetic sheet with slot, the magnetic sheet size is 43 ± 0.5mm, the inner hole is 5.3mm, and the thickness is 0.8 ± 0.1mm.

三、绕线参数 Winding Specification:

序号 NO.	端子 TERMINAL		线径 WIRE	圈数 Turns	绕线方向 Winding Direction
1	S	F	热风线 0.08*24P	10Ts	CCW

四、电气特性 ELECTRICAL CHARACTERISTICS:

温度 TEMPERATURE: 25 ± 10 °C, 湿度 RELATIVE HUMIDITY: 65 ± 20%

序号 NO.	项目 ITEM	端子 TERMINAL	标准 SPECIFICATION	测试条件 TEST FREQUENCY	测试仪器 TEST EQUIPMENTS
1	IND.	S-F	3.8uH ±10% 单独线圈	100KHz/1.0V	LCZ METER 1062B
2	IND.	S-F	6.8uH ±10% 加磁片	100KHz/1.0V	LCZ METER 1062B
3	DCR	S-F	≤ 50mΩ	100KHz/1.0V	LCZ METER 502B
4	Q	S-F	≤ 74	100KHz/1.0V	LCZ METER 502B

擬制/日期 PREPARED BY/DATE	審核/日期 CHECKED BY/DATE
Lin suling 2021.10.19	An n shuaiyin 2021.10.19