



TEST REPORT

Test Report No. : UL-RPT-RP-11834272-316FCC

Manufacturer : Festo Didactic SE
Model No. : CPS-Gate
Technology : RFID – 13.56 MHz
Test Standard(s) : FCC Parts 15.207, 15.209(a) & 15.225

1. This test report shall not be reproduced in full or partial, without the written approval of UL International Germany GmbH.
2. The results in this report apply only to the sample tested.
3. The test results in this report are traceable to the national or international standards.
4. Test Report Version 1.1 – Supersede the Version 1.0
5. Result of the tested sample: **PASS**

Prepared by: Segun, Adeniji
Title: Laboratory Engineer
Date: 17 October 2017

Approved by: Jakob Reschke
Title: Test Engineer
Date: 20 December 2017



Deutsche
Akkreditierungsstelle
D-PL-19381-02-00

This laboratory is accredited by DAkkS.
The tests reported herein have been performed in
accordance with its' terms of accreditation.

UL INTERNATIONAL GERMANY GMBH

Hedelfinger Str. 61
70327 Stuttgart, Germany
STU.CTECHLab@ul.com

This page has been left intentionally blank.

Table of Contents

1. Customer Information..... 4

2. Summary of Testing..... 5

 2.1. General Information 5

 Applied Standards 5

 Location 5

 Date information 5

 2.2. Summary of Test Results 6

 2.3. Methods and Procedures 6

 2.4. Deviations from the Test Specification 6

3. Equipment Under Test (EUT) 7

 3.1. Identification of Equipment Under Test (EUT) 7

 3.2. Description of EUT 7

 3.3. Modifications Incorporated in the EUT 7

 3.4. Additional Information Related to Testing 8

 3.5. Support Equipment 8

4. Operation and Monitoring of the EUT during Testing 9

 4.1. Operating Modes 9

 4.2. Configuration and Peripherals 9

5. Measurements, Examinations and Derived Results10

 5.1. General Comments 10

 5.2. Test Results 11

 5.2.1. Transmitter AC Conducted Spurious Emissions 11

 5.2.2. Transmitter Fundamental Field Strength 20

 5.2.3. Transmitter Frequency Stability (Temperature & Voltage Variation) 31

6. Measurement Uncertainty34

7. Used equipment35

8. Open-Area-Test Site comparison.....37

9. Report Revision History41

1. Customer Information

Company Name:	Festo Didactic SE
Company Address:	Rechbergstrasse 3, 73770 Denkendorf, Germany
Contact Person:	Andreas Hemminger
Contact E-Mail Address:	Andreas.Hemminger@festo.com
Contact Phone No.:	+49-(0)711-3467-1311

2. Summary of Testing

2.1. General Information

Specification Reference:	47CFR15.225
Specification Title:	Code of Federal Regulations Volume 47 (Telecommunications): Part 15 Subpart C (Radio Frequency Devices) - Section 15.225
Specification Reference:	47CFR15.207 and 47CFR15.209
Specification Title:	Code of Federal Regulations Volume 47 (Telecommunications): Part 15 Subpart C (Intentional Radiators) - Sections 15.207 and 15.209
Test Firm Registration:	399704

Applied Standards

Location

Location of Testing:	UL International Germany GmbH Hedelfinger Str. 61 70327 Stuttgart Germany
-----------------------------	--

Date information

Order Date:	22 June 2017
EUT arrived:	28 August 2017
Test Dates:	13 September 2017 to 13 December 2017
EUT returned:	-/-

2.2. Summary of Test Results

Clause	Measurement	Complied	Did not comply	Not performed	Not applicable
Part 15.207	Transmitter AC Conducted Emissions	<input checked="" type="checkbox"/>	<input type="checkbox"/>	<input type="checkbox"/>	<input type="checkbox"/>
Part 15.225(a)(b)(c)(d)	Transmitter Fundamental Field Strength	<input checked="" type="checkbox"/>	<input type="checkbox"/>	<input type="checkbox"/>	<input type="checkbox"/>
Part 15.209(a)/15.225(d)	Transmitter Radiated Emissions	<input checked="" type="checkbox"/>	<input type="checkbox"/>	<input type="checkbox"/>	<input type="checkbox"/>
Part 15.209(a)/15.225(c)(d)	Transmitter Band Edge Radiated Emissions	<input checked="" type="checkbox"/>	<input type="checkbox"/>	<input type="checkbox"/>	<input type="checkbox"/>
Part 15.225(e)	Transmitter Frequency Stability (Temperature & Voltage Variation)	<input checked="" type="checkbox"/>	<input type="checkbox"/>	<input type="checkbox"/>	<input type="checkbox"/>

2.3. Methods and Procedures

Reference:	ANSI C63.10-2013
Title:	American National Standard of Procedures for Compliance Testing of Unlicensed Wireless Devices
Reference:	KDB 414788 D01 Radiated Test Site v01
Title:	TEST SITES FOR RADIATED EMISSION MEASUREMENTS

2.4. Deviations from the Test Specification

For the measurements contained within this test report, there were no deviations from, additions to, or exclusions from the test specification identified above.

3. Equipment Under Test (EUT)

3.1. Identification of Equipment Under Test (EUT)

Brand Name:	Festo
Model Name or Number:	CPS-Gate
Serial Number:	2266312
Hardware Version Number:	2
Software Version Number:	Not stated
Firmware Version Number:	Not stated
FCC ID	2AMRG-CPSGATE

3.2. Description of EUT

The equipment under test was a Light industrial PLC including a pneumatic stopper incorporating an RFID technology.

3.3. Modifications Incorporated in the EUT

No modifications were applied to the EUT during testing.

3.4. Additional Information Related to Testing

Tested Technology:	RFID	
Category of Equipment:	Transceiver	
Channel Spacing:	Single channel device	
Transmit Frequency Range:	13.56 MHz	
Power Supply Requirement:	Nominal	24 VDC
	Minimum	20.4 VDC
	Maximum	28.8 VDC
Tested Temperature Range:	-20°C to 50°C	

3.5. Support Equipment

The following support equipment was used to exercise the EUT during testing:

Item	Description	Brand Name	Model Name or Number	Serial Number
1	Wiring set including load resistors and LED's for Dig. I/O Test	Not marked/stated	Not marked/stated	Not marked/stated
2	NFC Tag	Not marked/stated	Not marked/stated	Not marked/stated
3	Ethernet Switch	Not marked/stated	Not marked/stated	Not marked/stated
4	Ethernet cable	Not marked/stated	Not marked/stated	Not marked/stated
5	Power Supply	FESTO	D:AS-NG-PSU24V	8049633

4. Operation and Monitoring of the EUT during Testing

4.1. Operating Modes

The EUT was tested in the following operating mode(s):

- Constantly transmitting at full power with a modulated carrier in RFID test mode.

4.2. Configuration and Peripherals

The EUT was tested in the following configuration(s):

- The RFID transmitter test mode was enabled using instructions provided by the customer in document '*Test Proposal Form.pdf*' dated 08 September 2017.
- By placing an RFID Tag close to the EUT's RFID slot, the continuous transmission was enabled.
- Frequency stability tests were performed with the EUT connected to a variable power supply.
- The sample with serial number 2266312 was used for all tests.

5. Measurements, Examinations and Derived Results

5.1. General Comments

Measurement uncertainties are evaluated in accordance with current best practice. Our reported expanded uncertainties are based on standard uncertainties, which are multiplied by an appropriate coverage factor to provide a statistical confidence level of approximately 95%. Please refer to Section 6 *Measurement Uncertainty* for details.

In accordance with DAkkS requirements all the measurement equipment is on a calibration schedule. All equipment was within the calibration period on the date of testing.

5.2. Test Results

5.2.1. Transmitter AC Conducted Spurious Emissions

Test Summary:

Test Engineer:	Asim Shahzad	Test Date:	16.10.2017
Test Sample Serial Number:	2266312		
Test Site Identification	SR 7/8		

FCC Reference:	Part 15.207
Test Method Used:	ANSI C63.10 Section 6.2 / FCC KDB 174176 and Notes below

Environmental Conditions:

Temperature (°C):	22
Relative Humidity (%):	35

Settings of the Instrument

Detector	Quasi Peak/ Average Peak
-----------------	--------------------------

Note(s):

1. The EUT (EUT + 24V DC Power Supply) was connected to a 120 VAC 60 Hz single phase supply via a LISN.
2. The final measured value, for the given emission, in the table below incorporates the cable loss.
3. All other emissions shown on the pre-scan plot were investigated and found to be ambient or >20 dB below the applicable limit or below the measurement system noise floor.
4. Measurements were performed in shielded room (SR7/ 8 Asset Number 1603671). The EUT was placed at a height of 80 cm above the reference ground plane and in a distance of 40 cm from the vertical ground plane at the edge of the table

Transmitter AC Conducted Spurious Emissions (continued)

Test setup:

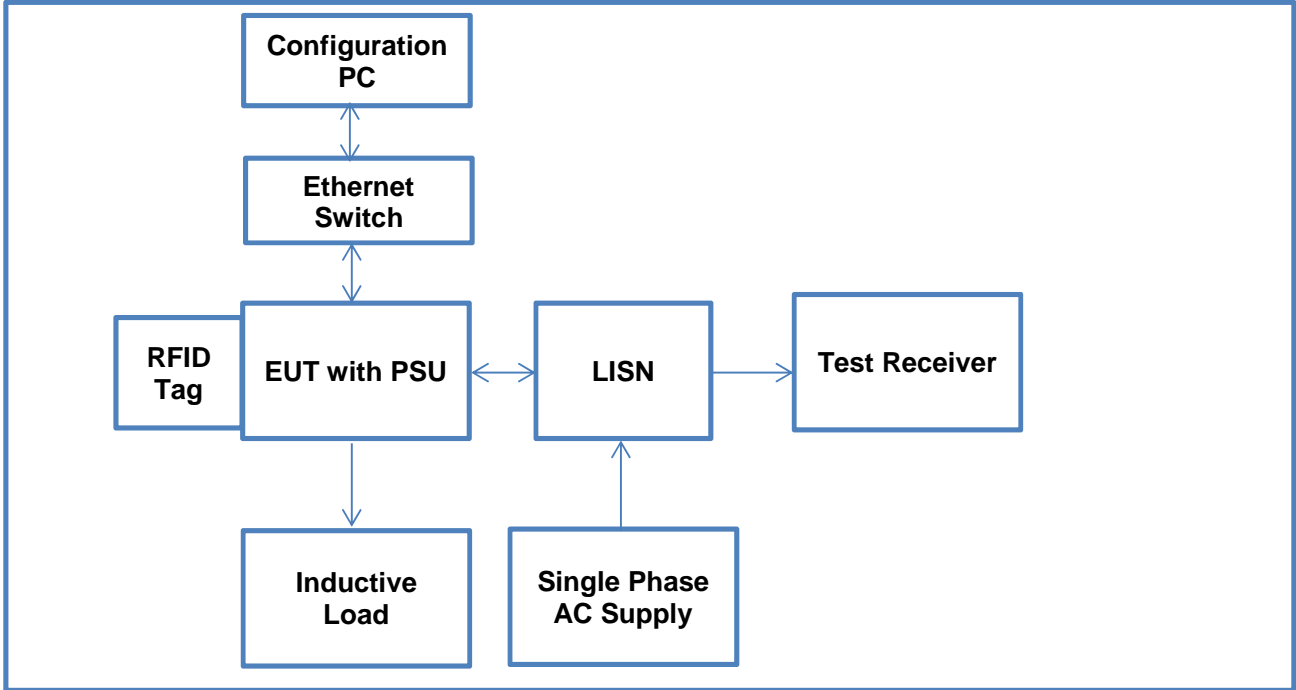

Results: Live / Quasi Peak

Frequency (MHz)	Line	Level (dB μ V)	Limit (dB μ V)	Margin (dB)	Result
0.15872	L	51.9	65.5	13.6	Pass
0.25368	L	24.2	61.6	37.4	Pass
0.34685	L	21.4	59	37.6	Pass
6.7663	L	33.6	60	26.4	Pass
18.12118	L	35.1	60	24.9	Pass
24.65272	L	37.5	60	22.5	Pass

Results: Live / Average

Frequency (MHz)	Line	Level (dB μ V)	Limit (dB μ V)	Margin (dB)	Result
0.15872	L	41.0	55.5	14.5	Pass
0.25368	L	13.3	51.6	38.3	Pass
0.34685	L	14.4	49	34.6	Pass
6.7663	L	32.7	50	17.3	Pass
18.12118	L	33.0	50	17.0	Pass
24.65272	L	36.3	50	13.7	Pass

Result: Pass

Results: Neutral / Quasi Peak

Frequency (MHz)	Line	Level (dB μ V)	Limit (dB μ V)	Margin (dB)	Result
0.16295	N	46.3	65.3	19.0	Pass
0.23645	N	30.1	62.2	32.1	Pass
0.46093	N	29.0	56.7	27.7	Pass
6.7684	N	32.6	60	27.4	Pass
18.12395	N	35.0	60	25.0	Pass
24.65917	N	34.4	60	25.6	Pass

Results: Neutral / Average

Frequency (MHz)	Line	Level (dB μ V)	Limit (dB μ V)	Margin (dB)	Result
0.16295	N	35.7	55.3	19.6	Pass
0.23645	N	24.2	52.2	28.0	Pass
0.46093	N	28.6	46.7	18.1	Pass
6.7684	N	31.7	50	18.3	Pass
18.12395	N	33.3	50	16.7	Pass
24.65917	N	33.3	50	16.7	Pass

Result: Pass

Transmitter Mode Conducted Spurious Emissions (continued)

Phase L

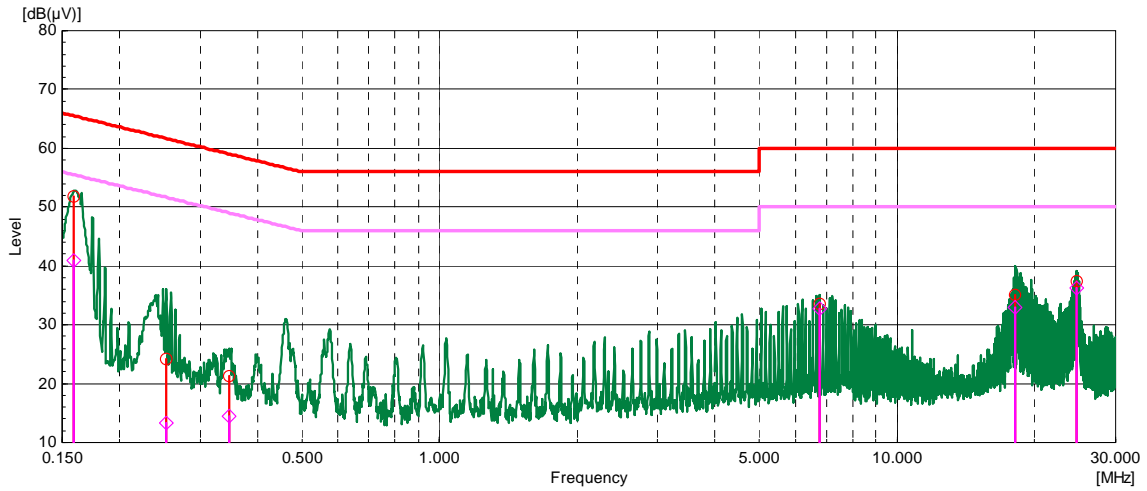

Phase N

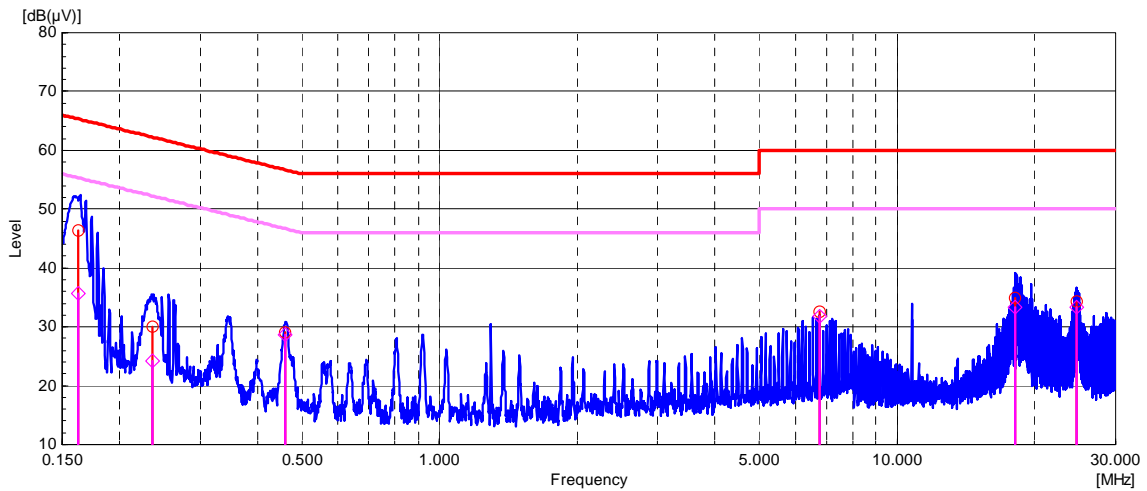

Note: This plot is a pre-scan and for indication purposes only. For final measurements, see accompanying table.

Note: The carrier of the RFID transmitter has been identified during pre-scan measurement at a frequency of 13.56313MHz with a carrier level of < 30dBµV.

Transmitter AC Conducted Spurious Emissions (continued)

Test setup: RFID Tag removed

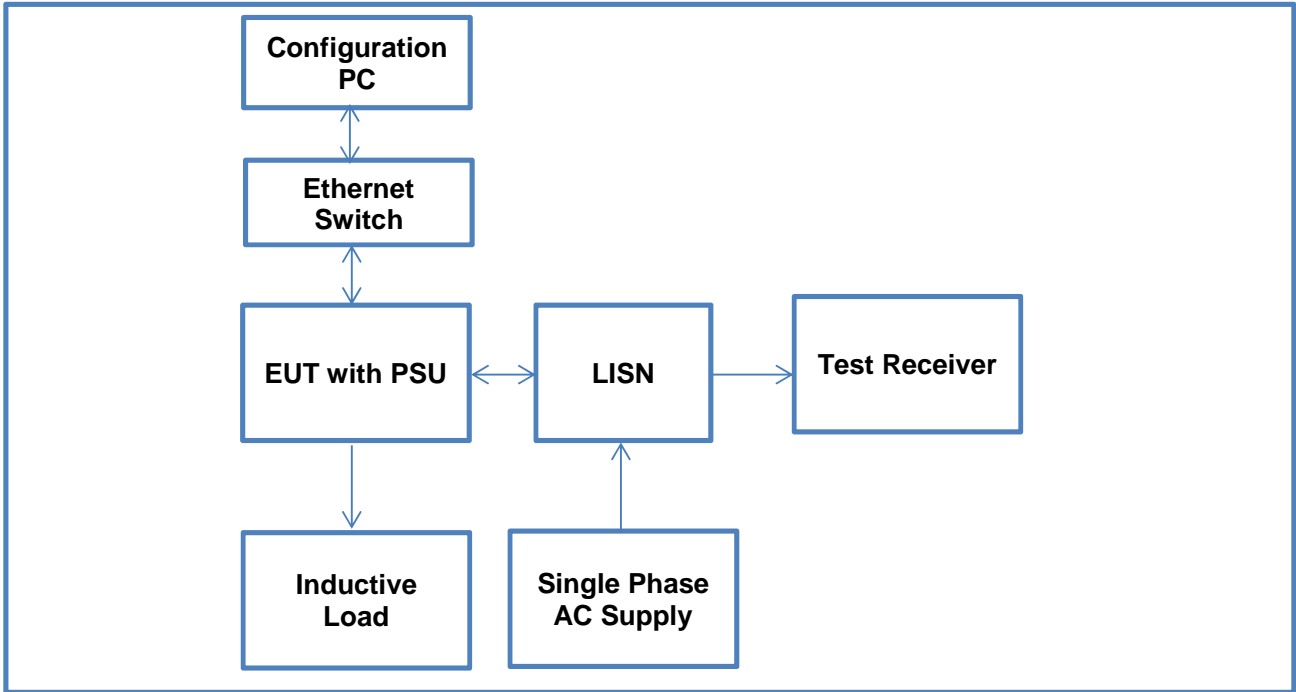

Results: Live / Quasi Peak

Frequency (MHz)	Line	Level (dB μ V)	Limit (dB μ V)	Margin (dB)	Result
0.15904	L	51.8	65.5	13.7	Pass
0.25337	L	24.0	61.6	37.6	Pass
0.3459	L	22.4	59.1	36.7	Pass
6.75756	L	32.0	60.0	28.0	Pass
18.10116	L	32.4	60.0	27.6	Pass
24.63273	L	38.9	60.0	21.1	Pass

Results: Live / Average

Frequency (MHz)	Line	Level (dB μ V)	Limit (dB μ V)	Margin (dB)	Result
0.15904	L	40.9	55.5	14.6	Pass
0.25337	L	13.0	51.6	38.6	Pass
0.3459	L	17.4	49.1	31.7	Pass
6.75756	L	30.4	50.0	19.6	Pass
18.10116	L	31.5	50.0	18.5	Pass
24.63273	L	37.0	50.0	13.0	Pass

Result: Pass

Results: Neutral / Quasi Peak

Frequency (MHz)	Line	Level (dB μ V)	Limit (dB μ V)	Margin (dB)	Result
0.16193	N	47.9	65.4	17.5	Pass
0.2374	N	30.9	62.2	31.3	Pass
0.45849	N	30.5	56.7	26.2	Pass
6.75932	N	29.7	60.0	30.3	Pass
18.10225	N	28.8	60.0	31.2	Pass
24.63357	N	36.3	60.0	23.7	Pass

Results: Neutral / Average

Frequency (MHz)	Line	Level (dB μ V)	Limit (dB μ V)	Margin (dB)	Result
0.16193	N	37.2	55.4	18.2	Pass
0.2374	N	24.9	52.2	27.3	Pass
0.45849	N	30.1	46.7	16.6	Pass
6.75932	N	28.7	50.0	21.3	Pass
18.10225	N	27.5	50.0	22.5	Pass
24.63357	N	34.5	50.0	15.5	Pass

Result: Pass

Transmitter Mode Conducted Spurious Emissions (continued)

Phase L

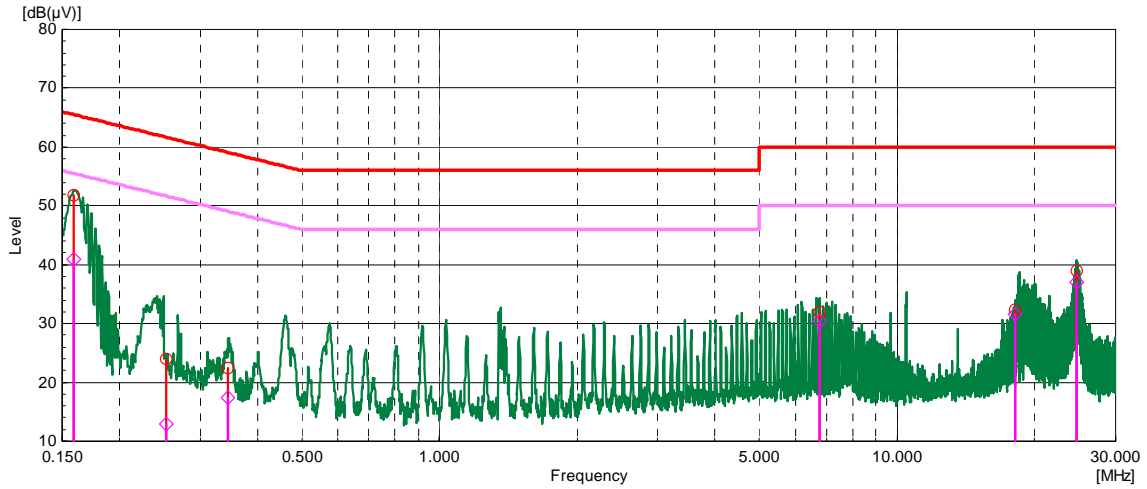

Phase N

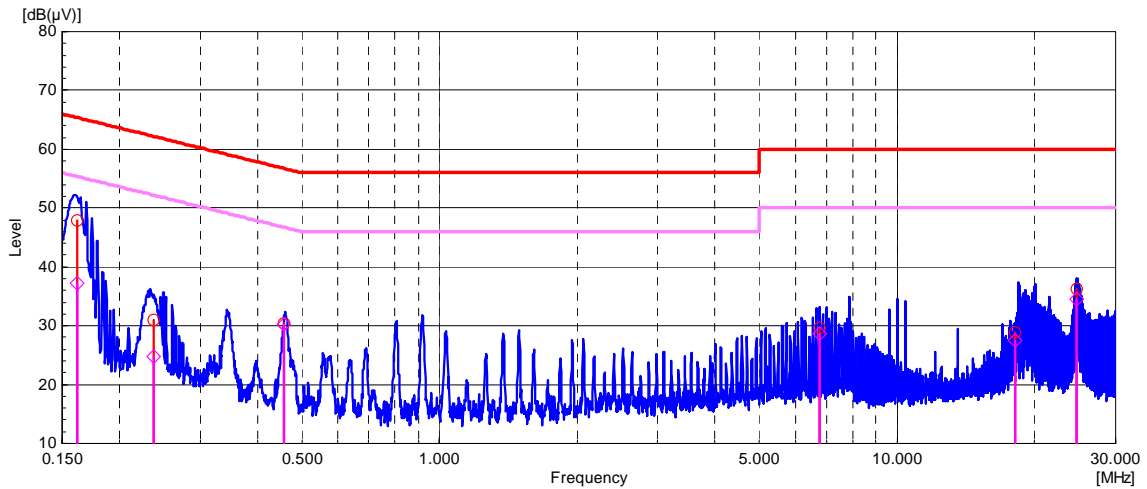

Note: This plot is a pre-scan and for indication purposes only. For final measurements, see accompanying table.

Note: The carrier of the RFID transmitter has been identified during pre-scan measurement at a frequency of 13.56313MHz with a carrier level of < 30dBμV.

5.2.2. Transmitter Fundamental Field Strength

Test Summary:

Test Engineer:	Segun Adeniji	Test Date:	14 September 2017
Test Sample Serial Number:	2266312		
Test Site Identification	SR 1/2		

FCC Reference:	Part 15.225(a)(b)(c)(d)
Test Method Used:	ANSI C63.10 Section 6.4

Environmental Conditions:

Temperature (°C):	22.5
Relative Humidity (%):	62

Settings of the Instrument

RBW/VBW	10 kHz/30 kHz
Span	1.0 MHz
Sweep time	25 ms
Detector	Peak

Note(s):

1. The limit is specified at a test distance of 30 metres. However, as specified by FCC Section 15.31 (f)(2), measurements may be performed at a closer distance and the measured level corrected to the specified measurement distance by using the square of an inverse linear distance extrapolation factor (40dB/decade).
2. In accordance with 414788 D01 Radiated Test Site v01 an alternative Test Site was used. Instead of an OATS a Semi Anechoic Chamber was used where evidence was shown that the behaviour is the same. A maximum deviation of 1.38dB for 13.56 MHz could be determined. This deviation is also taken into account to the result.
3. The measurement was performed at a measurement distance of 3 m where field strength of 49.83 dBuV/m was measured. This value was later extrapolated to a distance of 30 m by subtracting 40 dB from the result.
4. Pre-scan measurements were performed using a spectrum analyser with a peak detector and measurement bandwidth of 10 kHz. The fundamental field strength was maximized by rotating the measurement antenna and EUT. The spectrum analyser was then switched to test receiver mode and the final measurement on the maximized level was performed. In accordance with ANSI C63.10 Clause 4.2.3.2.1 and CISPR 16-1-1, a quasi-peak detector was used in conjunction with a measurement bandwidth of 9 kHz and 0.2 second sweep time. A quasi-peak level 49.83 dBµV/m was recorded. The quasi-peak level of 49.83 dBµV/m is the fundamental field strength at 3 meters. The corrected level to the specified measurement distance (using a linear distance extrapolation factor of 40 dB/decade) is 9.83 dBµV/m.
5. Compliance with the spectrum mask is shown by final measurements performed in a semi-anechoic chamber. For the field strength measurements in a semi-anechoic chamber, a transducer factor on the measuring instrument was used to extrapolate the results at 3 metres to a distance of 30 metres. A distance extrapolation factor of 40 dB was used.
6. A transducer factor was used on the spectrum analyser during measurement. This factor includes correction between the fixed gain of the magnetic loop antenna and the calibration values. It also includes the value of the RF cable used to connect the antenna to the spectrum analyser which was incorporated into the annual calibration of the magnetic loop antenna.

Transmitter Fundamental Field strength test setup

Open Area Test Site

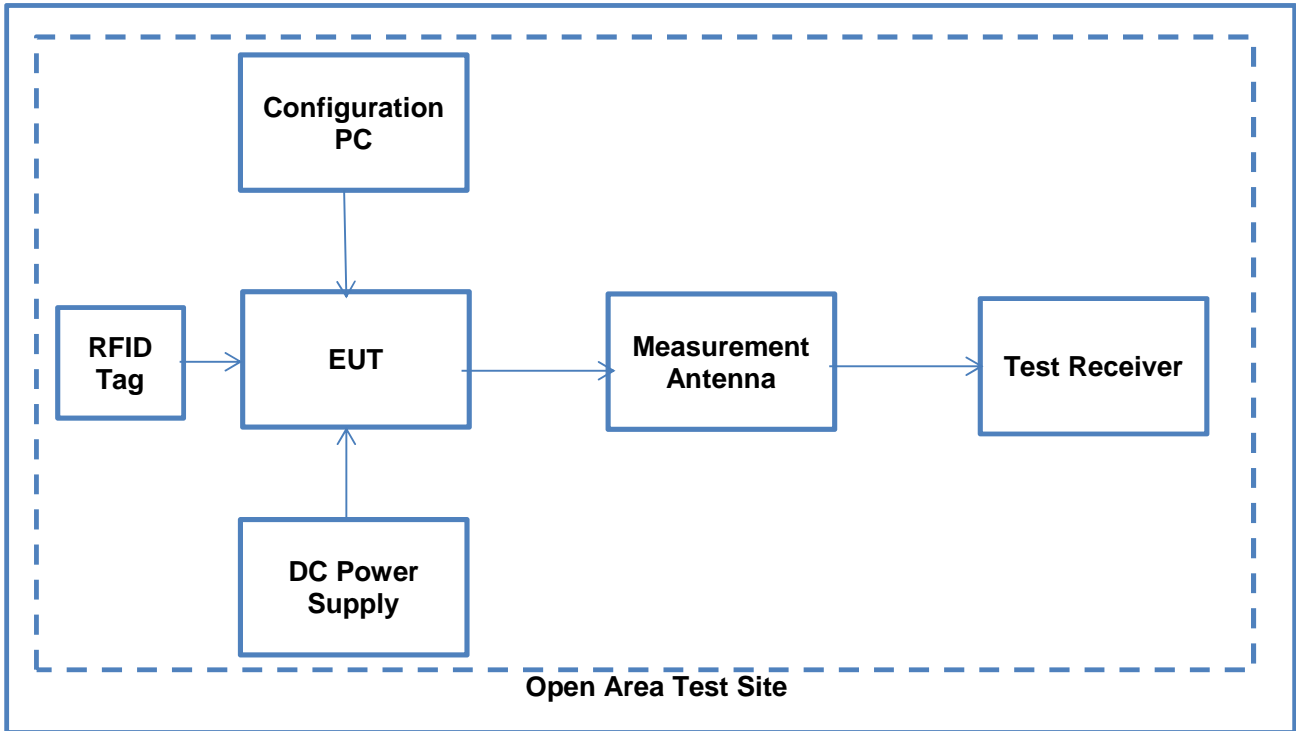

Semi Anechoic Chamber

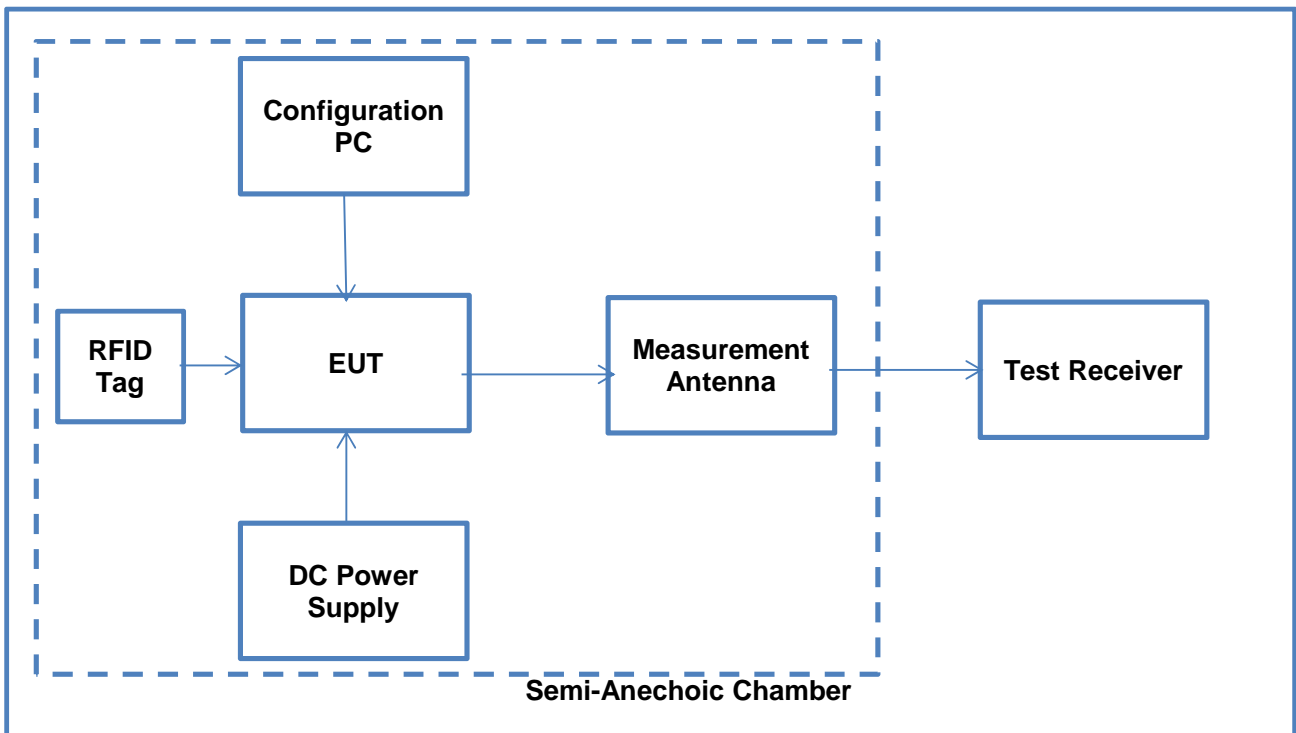

Results: Quasi Peak

Frequency (MHz)	Antenna Polarity	Level at 3 m (dB μ V/m)	Level at 30 m (dB μ V/m)	Deviation from OATS to SAC	Level at 30 m (dB μ V/m) with deviation added	Limit at 30 m (dB μ V/m)	Margin (dB)	Result
13.56	0° to EUT	49.83	9.83	1.38	11.21	84.0	72.79	Pass

Result: Pass

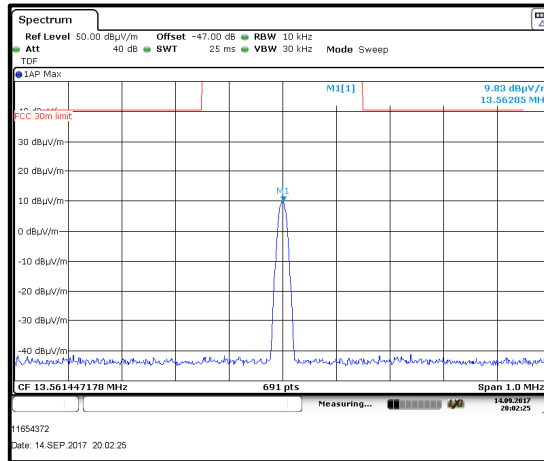

Plot 1: Fundamental field strength and spectrum mask / measured at 3 metres extrapolated to 30 metres / measured in a semi-anechoic chamber

5.2.2.1. Transmitter Radiated Spurious Emissions

Test Summary:

Test Engineer:	Segun Adeniji	Test Date:	13 September 2017
Test Sample Serial Number:	2266312		
Test Site Identification	1/2		

FCC Reference:	Parts 15.225(d) & 15.209(a)
Test Method Used:	ANSI C63.10 Sections 6.3, 6.4 and 6.5
Frequency Range:	9 kHz to 1000 MHz

Environmental Conditions:

Temperature (°C):	22
Relative Humidity (%):	62

Settings of the Instrument

Frequency Range	RBW	VBW	Detector
9 kHz-150 kHz	300 Hz	1 KHz	Peak Detector
150 kHz-30 MHz	10 KHz	30 kHz	Peak Detector
30 MHz-1 GHz	100 kHz	300 kHz	Peak Detector

Note(s):

1. In accordance with FCC KDB 414788, an alternative test site may be used for the measurement. Therefore the result from the semi-anechoic chamber tests on 15th September 2017 is shown in this section of the test report.
2. The final measured value, for the given emission, in the table below incorporates the calibrated antenna factor and cable loss. Only spurious emissions in the range 30 MHz to 1 GHz were recorded. Markers were placed on the peaks of the prescan plot and final measurements were performed using a quasi peak detector.
3. All other emissions were greater than 20 dB below the applicable limit, below the noise floor of the measurement system or ambient.
4. Measurements on 13th September 2017 were performed in a semi-anechoic chamber at a distance of 3 metres. The EUT was placed at a height of 80 cm above the reference ground plane in the centre of the chamber turntable. Between 30 MHz and 1 GHz, maximum emission levels were determined by height searching the measurement antenna over the range 1 metre to 4 metres.
5. A transducer factor was used on the spectrum analyser during open field tests. This factor includes correction between the fixed gain of the magnetic loop antenna and the calibration values. It also includes the value of the RF cable used to connect the antenna to the spectrum analyser which was incorporated into the annual calibration of the magnetic loop antenna.

Transmitter Radiated Spurious Emission test setup (Measurement below 30 MHz)

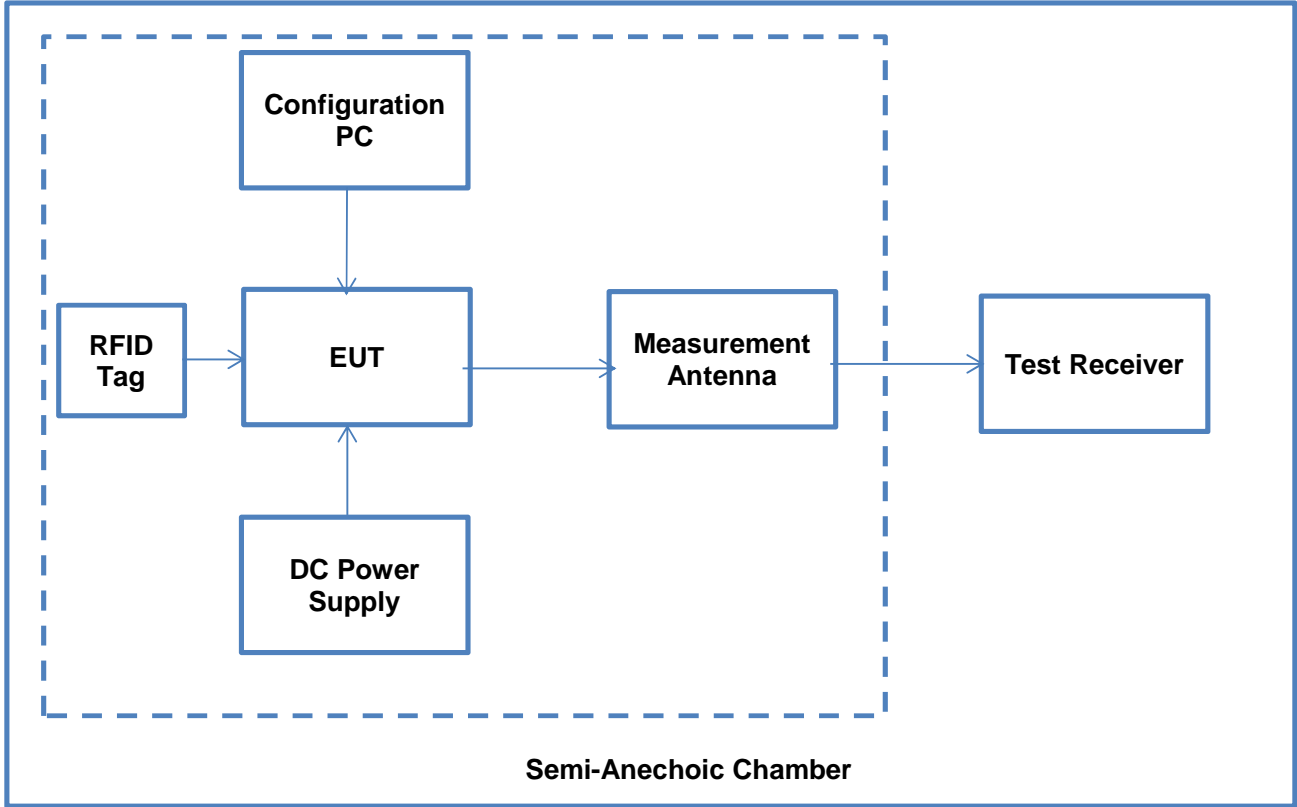

Receiver/Idle Mode Radiated Spurious Emissions (continued)

Setup for radiated measurements: Semi-anechoic chamber for measurement up to 1 GHz

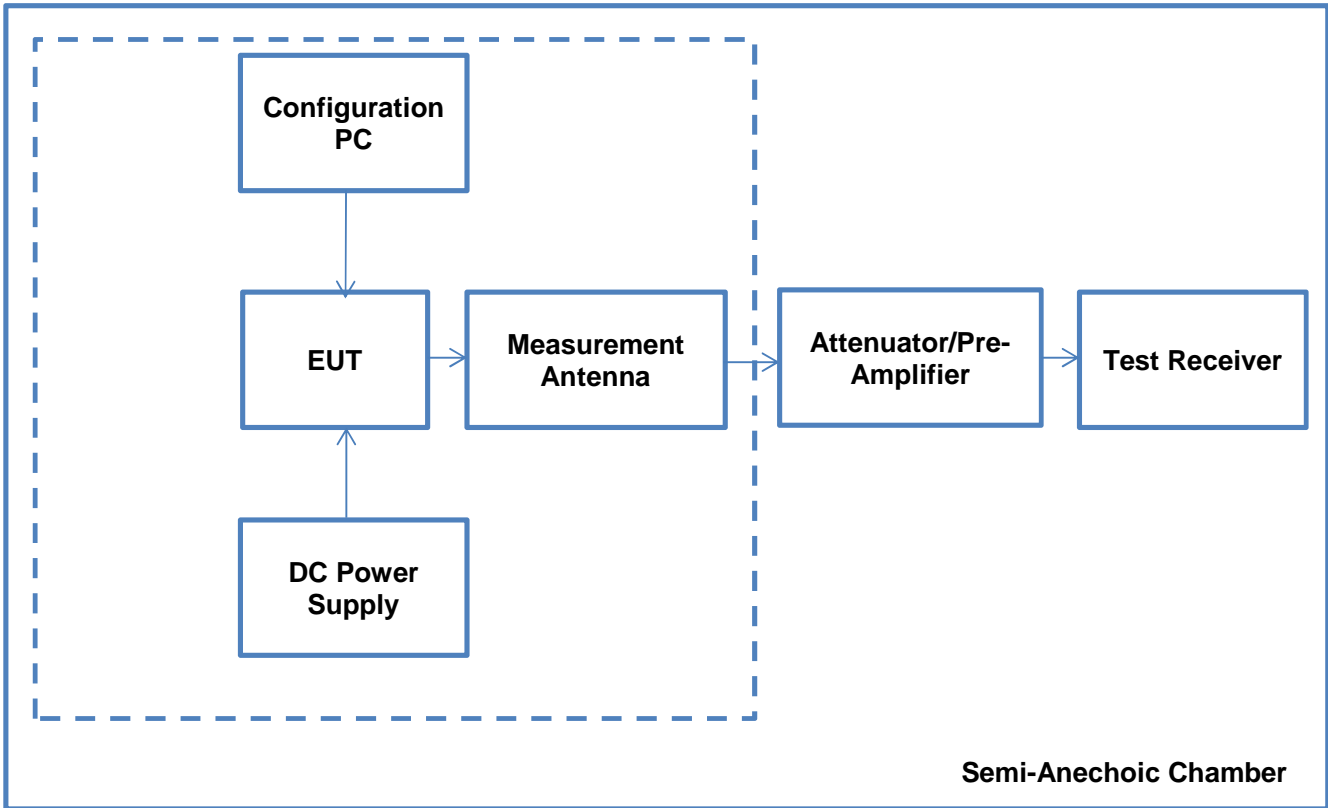

Results: Quasi Peak

Frequency (MHz)	Antenna Polarity	Level (dB μ V/m)	Limit (dB μ V/m)	Margin (dB)	Result
42.420000	V	28.19	40.00	11.81	Complied
43.005000	V	29.30	40.00	10.70	Complied
83.415000	V	29.58	40.00	10.42	Complied
87.960000	V	29.01	40.00	10.99	Complied
286.905000	H	34.79	46.00	11.21	Complied
400.466667	H	33.45	46.00	12.55	Complied

Result: Pass

Transmitter Radiated Spurious Emissions (continued)

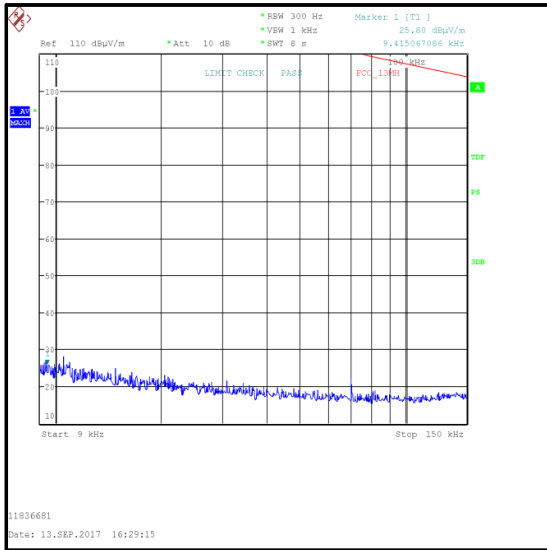

9 kHz to 150 kHz / peak detector / 300 Hz measured at 3 metres extrapolated to 30 metres / measured in a semi-anechoic chamber

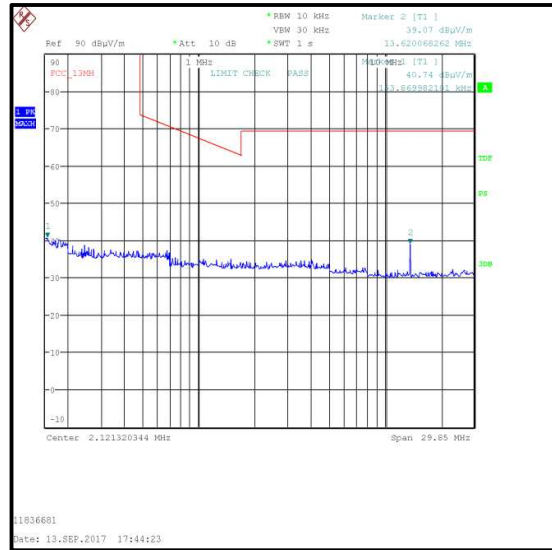

150 kHz to 30 MHz / peak detector / 10 kHz measured at 3 metres extrapolated to 30 metres / measured in a semi-anechoic chamber

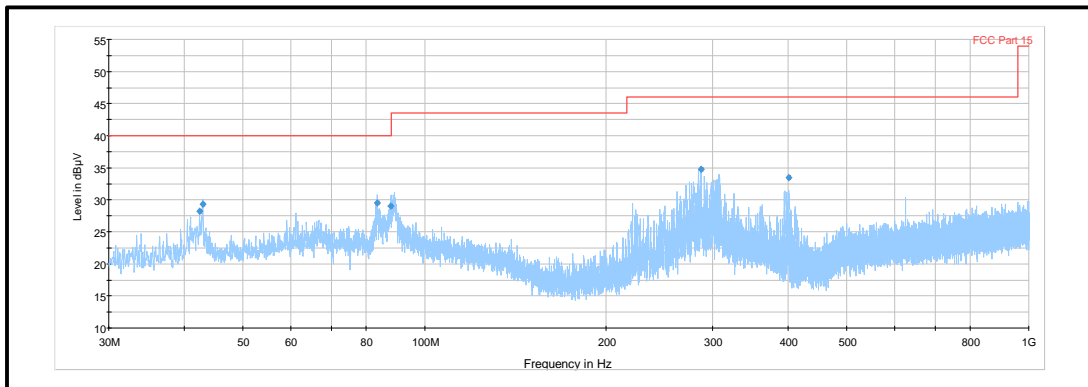

30 MHz to 1 GHz / peak detector (worst case) / measured at 3 metres in a semi-anechoic chamber

Note: These plots are pre-scans and for indication purposes only. For final measurements, see accompanying table.

5.2.2.2. Transmitter Band Edge Radiated Emissions

Test Summary:

Test Engineer:	Segun Adeniji	Test Date:	15 September 2017
Test Sample Serial Number:	2266312		
Test Site Identification	1/2		

FCC Reference:	Parts 15.225(c)(d) & 15.209(a)
Test Method Used:	ANSI C63.10 Section 6.10.4 and Notes below

Environmental Conditions:

Temperature (°C):	22
Relative Humidity (%):	62

Settings of the Instrument

RBW/VBW	10 kHz/30 kHz
Span	1 MHz
Sweep time	Auto
Detector	Peak

Note(s):

1. In accordance with FCC KDB 414788, an alternative test site may be used for the measurement. Therefore the result from the semi-anechoic chamber tests on 15th September 2017 is shown in this section of the test report.
2. For the field strength measurements in a semi-anechoic chamber, a transducer factor on the measuring instrument was used to extrapolate the results at 3 metres to a distance of 30 metres as required. A distance extrapolation factor of 40 dB was used.
3. The plot below is the result obtained with the test receiver resolution bandwidth set to 10 kHz and video bandwidth 30 kHz. A peak detector was used, sweep time was set to auto and the trace mode was Max Hold. The span was set to 1 MHz. The measurement was repeated with a quasi-peak detector and the results obtained are given in the table below.

Transmitter Band Edge Radiated Emissions test setup

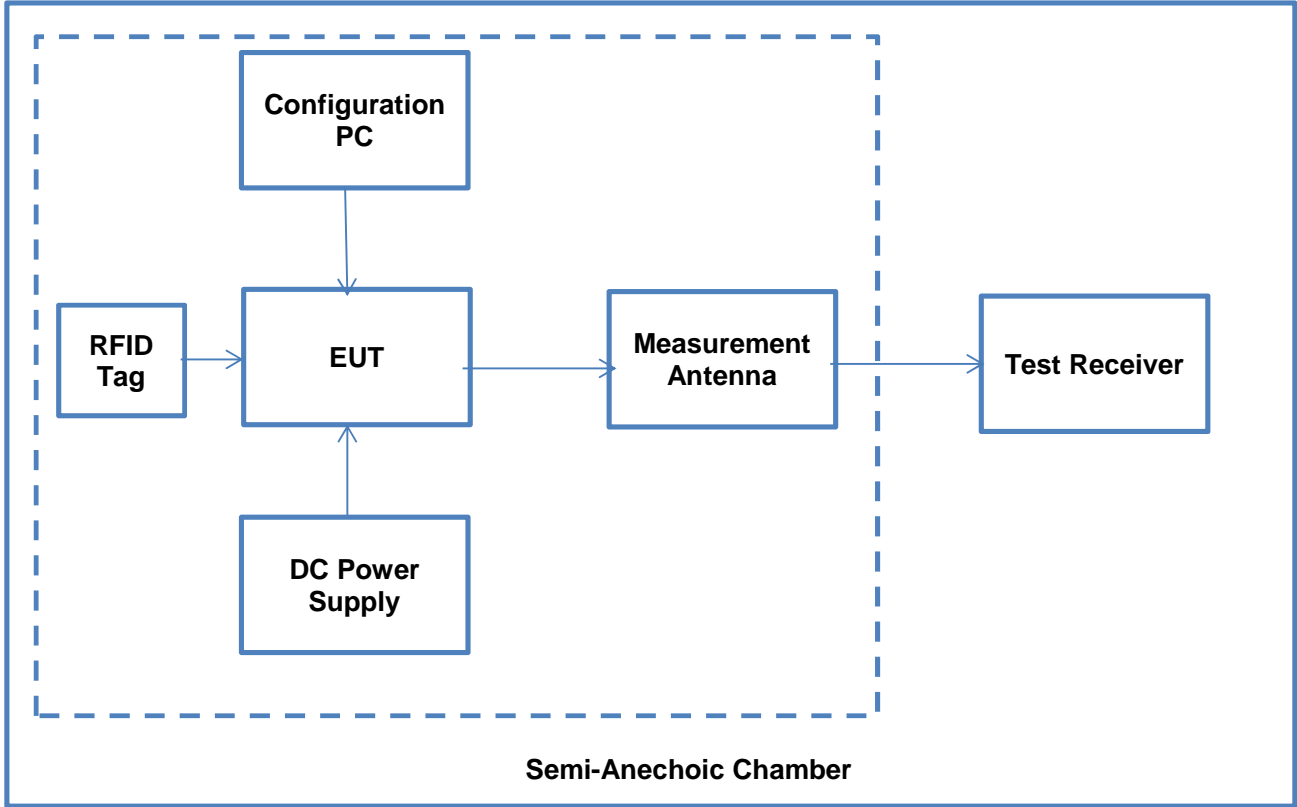

Results: Quasi Peak / Lower Band Edge

Frequency (MHz)	Level (dB μ V/m)	Limit (dB μ V/m)	Margin (dB)	Result
13.11	-24.73	29.5	-54.23	Complied

Results: Quasi Peak / Upper Band Edge

Frequency (MHz)	Level (dB μ V/m)	Limit (dB μ V/m)	Margin (dB)	Result
14.01	-24.73	29.5	-54.23	Complied

Result: Pass

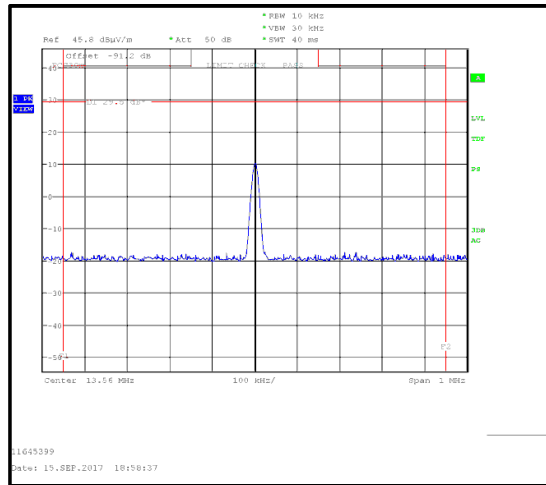

5.2.3. Transmitter Frequency Stability (Temperature & Voltage Variation)**Test Summary:**

Test Engineer:	Segun Adeniji	Test Date:	13 December 2017
Test Sample Serial Number:	2266312		
Test Site Identification	SR 9		

FCC Reference:	Part 15.225(e)
Test Method Used:	ANSI C63.10 Section 6.8.1 and 6.8.2

Environmental Conditions:

Ambient Temperature (°C):	23.3
Ambient Relative Humidity (%):	39.5

Settings of the Instrument

RBW/VBW	300 Hz/1 kHz
Span	10 kHz
Sweep time	1 s
Detector	Peak

Note(s):

1. Testing at voltage extremes was performed with the EUT powered by a variable DC power supply.
2. Frequency stability measurements were performed with a modulated carrier. The measurements were performed using the spectrum analyser marker counter function. The marker counter function was set to 1 Hz before any measurements were performed.

Transmitter Frequency Stability Emissions test setup

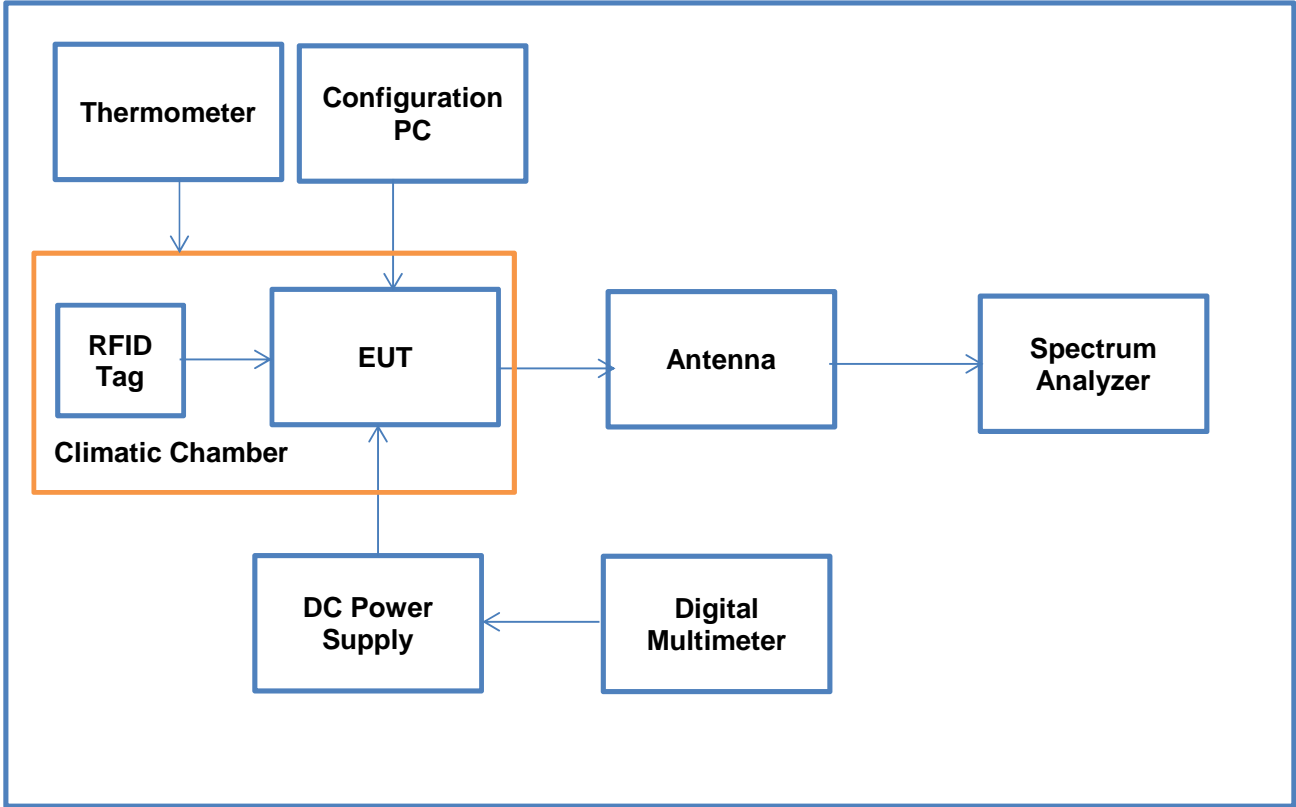

Results: Maximum frequency error of the EUT with variations in ambient temperature

Temperature (°C)	Time after Start-up			
	0 minutes	2 minutes	5 minutes	10 minutes
-20	13.5608769	13.5608879	13.5609114	13.5609160
-10	13.5608773	13.5608877	13.5609111	13.5609158
0	13.5608777	13.5608880	13.5609115	13.5609159
5	13.5608774	13.5608881	13.5609117	13.5609160
10	13.5608674	13.5608610	13.5608581	13.5608559
20	13.5608732	13.5608731	13.5608731	13.5608732
30	13.5608674	13.5608611	13.5608581	13.5608560
40	13.5608773	13.5608877	13.5609110	13.5609160
45	13.5608678	13.5608613	13.5608584	13.5608568
50	13.5608774	13.5608879	13.5609110	13.5609159

Frequency with Worst Case Deviation (MHz)	Frequency Error (Hz)	Frequency Error (%)	Limit (%)	Margin (%)	Result
13.5609160	916	0.006755162	0.01	0.003245	Complied

Results: Maximum frequency error of the EUT with variations in nominal operating voltage at an ambient temperature of 20°C

Supply Voltage (V)	Nominal Frequency (MHz)	Measured Frequency (MHz)	Frequency Error (Hz)	Frequency Error (%)	Limit (%)	Margin (%)	Result
20.4	13.56	13.5608751	875.1	0.006445354	0.01	0.003546	Complied
22.8	13.56	13.5608744	874.4	0.006448378	0.01	0.003552	Complied
25.2	13.56	13.5608758	875.8	0.006458702	0.01	0.003541	Complied
27.6	13.56	13.5608752	875.2	0.006454277	0.01	0.003546	Complied

Result: Pass

6. Measurement Uncertainty

The expression of uncertainty of a measurement result allows realistic comparison of results with reference values and limits given in specifications and standards.

The uncertainty of the result may need to be taken into account when interpreting the measurement results.

The reported expanded uncertainties below are based on a standard uncertainty multiplied by an appropriate coverage factor such that a confidence level of approximately 95% is maintained. For the purposes of this document "approximately" is interpreted as meaning "effectively" or "for most practical purposes".

Measurement Type	Range	Confidence Level (%)	Calculated Uncertainty
AC Conducted Spurious Emissions	0.15 MHz to 30 MHz	95%	±4.69 dB
Frequency Stability	13 MHz to 14 MHz	95%	±0.92 ppm
Radiated Spurious Emissions	9 kHz to 30 MHz	95%	±2.53 dB
Radiated Spurious Emissions	30 MHz to 1000 MHz	95%	±2.53 dB
Transmitter Fundamental Field Strength	13 MHz to 14 MHz	95%	±3.73 dB

The methods used to calculate the above uncertainties are in line with those recommended within the various measurement specifications. Where measurement specifications do not include guidelines for the evaluation of measurement uncertainty the published guidance of the appropriate accreditation body is followed.

7. Used equipment

Test site: SR 1/ 2

ID	Manufacturer	Type	Model	Serial No.	Calibration Date	Cal. Cycle
1	Rohde & Schwarz	Antenna, Loop	HFH2-Z2	831247/012	8/5/2016	36
103	EMCO	Antenna, Horn	3115	9008/3485	7/20/2016	36
104	EMCO	Antenna, Horn	3115	9008/3486	7/20/2016	36
156	Rohde & Schwarz	V-Network	ESH3-Z6	843864/004	7/12/2017	12
350	Rohde & Schwarz	Receiver, EMI Test	ESIB7	836697/014	7/13/2017	12
377	BONN Elektronik	Amplifier, Low Noise Pre	BLMA 0118-1A	025294B	7/11/2017	12
383	Rohde & Schwarz	Antenna, Rod	HFH2-Z1	890151/11	7/14/2017	24
423	Bonn Elektronik	Amplifier, Low Noise Pre	BLMA 1840-1A	055929	7/12/2017	12
424	EMCO	Antenna, Horn	EMCO 3116	00046537	7/28/2016	24
425	Agilent	Generator, CW Signal	E8247C	MY43320849	7/19/2016	24
426	Agilent	Spectrum Analyzer	E4446A	US44020316	7/20/2016	24
460	Deisl	Turntable	DT 4250 S		n/a	n/a
465	Schwarzbeck	Antenna, Trilog Broadband	VULB 9168	9168-240	8/8/2016	36
474	Agilent	Analyzer, ENA Network	E5071C	MY46100912	7/20/2016	24
495	Rohde & Schwarz	Antenna, Log.- Periodical	HL050	100296	7/20/2016	24
496	Rohde & Schwarz	Antenna, log. - periodical	HL050	100297	7/20/2016	24
497	Schwarzbeck	Antenna, Biconical	VHBB 9124	423	7/7/2016	36
499	Schwarzbeck	Antenna, log.-per	VUSLP 9111	317	8/2/2016	36
587	Maturo	antenna mast, tilting	TAM 4.0-E	011/7180311	n/a	n/a
588	Maturo	Controller	NCD	029/7180311	n/a	n/a
591	Rohde & Schwarz	Receiver	ESU 40	100244/040	7/12/2017	12
607	Schwarzbeck	Antenna broadband horn antenna	BBHA 9170	9170-561	7/28/2016	24
608	Rohde & Schwarz	Switch Matrix	OSP 120	101227	4/8/2014	60
363	Wainwright	Notch Filter GSM900	WW-NF9	100002	Lab verification	n/a
611	Wainwright Instruments	Band Reject Filter DL LTE	WRCGV8-	1	Lab verification	n/a
612	Wainwright Instruments	Band Reject Filter UL LTE	WRCGV8-	1	Lab verification	n/a
613	Wainwright Instruments	Band Reject Filter WLAN/ BT	WRCTF12-	1	Lab verification	n/a
614	Wainwright Instruments	Highpass Filter 3GHz	WHKX10-	1	Lab verification	n/a
615	Wainwright Instruments	Highpass Filter 1GHz	WHKX12-	3	Lab verification	n/a
620	Bonn Elektronik	pre-amplifier	BLNA 0110-01N	1510111	7/12/2017	24
624	Wainwright	6 GHz high-pass filter	WHKX10-5850-6500-18000-40SS	5	9/6/2016	60
628	Maturo	Antenna mast	CAM 4.0-P	224/19590716	n/a	n/a
629	Maturo	Kippeinrichtung	KE 2.5-R-M	MAT002	n/a	n/a

Test site: SR 7/8

ID	Manufacturer	Type	Model	Serial No.	Calibration Date	Cal. Cycle
22	Rohde & Schwarz	Artificial Mains	ESH3-Z5	831767/014	7/12/2017	12
23	Rohde & Schwarz	Artificial Mains	ESH3-Z5	831767/013	7/12/2017	12
215	Rohde & Schwarz	Artificial Mains Network	ESH2-Z5	879675/002	7/12/2017	12
229	Schwarzbeck	Absorbing Clamp	MDS21	03020	7/27/2016	24
349	Rohde & Schwarz	Receiver, EMI Test	ESIB7	836697/009	9/4/2017	12
351	Rohde & Schwarz	network, Artificial Mains	ESH3-Z5	862770/018	7/12/2017	12
505	Luethi Feinmechanik AG	Absorbing clamp	MDS21	100005	7/27/2016	24
514	matur	Gliderail & Controller	CGR 5.4 & SCU		n/a	0
564	Teseq	Impedance stabilisation network (ISN)	ISN T800	26076	7/20/2016	24
616	Rohde & Schwarz	ISN	ENY81-CA6	101656	7/13/2017	12

Test site: SR 9

ID	Manufacturer	Type	Model	Serial No.	Calibration Date	Cal. Cycle
424	EMCO	Antenna, Horn	EMCO 3116	00046537	7/28/2016	24
472	Rohde & Schwarz	Generator, Vektorsignal	SMU200A	102409	7/11/2017	12
592	Rohde & Schwarz	Wideband Radio Communication tester	CMW 500	119593	8/15/2017	12
622	Rohde & Schwarz	Step Attenuator	RSC	101904	7/13/2017	12
625	Schwarzbeck	Antenna, H-field	HFSL 7101	109	Verification - only relative measurements	n/a
626	Rohde & Schwarz	Bluetooth Tester	CBT	100481	Signaling Only	24
634	Rohde & Schwarz	Wireless Devices Test System	TS8997		7/11/2017	12
635	Rohde & Schwarz	Signal generator	SMB100A	179875	7/11/2017	12
636	Rohde & Schwarz	switching unit	OSP120	101698	7/14/2017	12
637	Rohde & Schwarz	Spectrum Analyzer	FSV40	101587	7/11/2017	12
423	Bonn Elektronik	Amplifier, Low Noise Pre	BLMA 1840-1A	55929	7/21/2016	24
195	SPS	Power Supply	TOE8842-24	51455	Verified by Multimeter	12
216	Agilent	Multimeter	34401A	US36017458	7/11/2017	24
378	ESPEC/ ThermoTec	Climatic Chamber	PL-1FT	5100869	8/9/2016	36

8. Open-Area-Test Site comparison

GPS coordinates

48.765746, 9.250684



The following listed equipment was used for the measurement:

Manufacturer	Type	Model	Frequency Range
Rohde & Schwarz	Receiver, EMI Test	SML03	9 kHz – 30 MHz
Rohde & Schwarz	Receiver, EMI Test	ESIB7	20 Hz – 7 GHz
Rohde & Schwarz	Antenna, Loop	HFH2-Z2	1 kHz – 30 MHz
ETS LINDGREN	Antenna, Loop	6512	1 kHz – 30 MHz
Huber and Suhner	RF Cable	-	-
Elspec	BNC Cable	-	-

The transmit signal to the ETS Lindgren loop antenna is supplied by the SML signal generator.

The distance of the transmit and receive Antenna was 3m. No other distances can be achieved in SR1 so 10m and 30m distances are not possible. Due to this no comparison is possible.

The Results are valid for equipment which is not larger as the loop antenna which represents in the comparison the EUT.

If an EUT is bigger measurements on an OATS are needed.

The measurement was performed on the lowest frequency 9 kHz and was increased by 10 kHz Steps up to 100 kHz. Then the step size was 100 kHz up to 1000 kHz. From 1 MHz up to the last frequency of 30 MHz the step size was 1 MHz. The HFH2-Z2 loop antenna placed at 80 cm height was used as the receive antenna. The intercepted RF signal from this antenna was measured with the ESIB7 Test Receiver and the values were recorded accordingly.

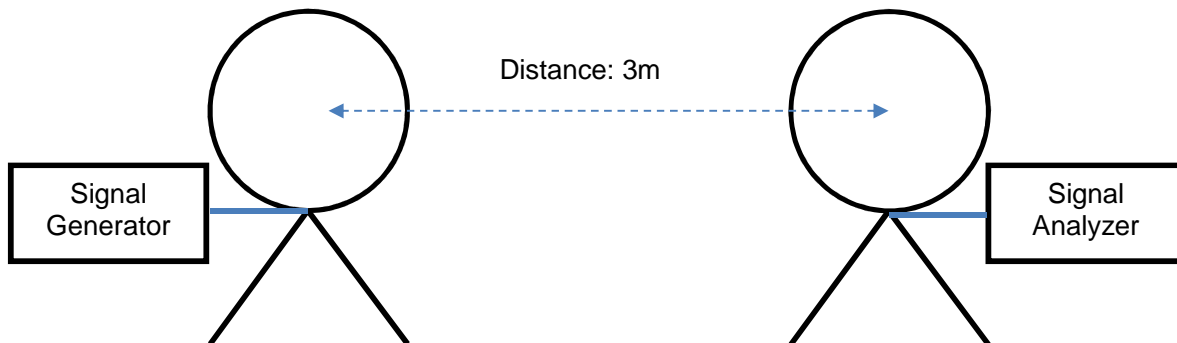

Numeric values

Frequency (MHz)	0.01	0.02	0.03	0.04	0.05	0.06	0.07	0.08	0.09	0.10	0.125	0.20
SR1 Measured power (dBµV)	87.91	87.22	87.01	86.98	86.40	86.32	85.98	85.20	84.30	83.80	82.96	82.55
OATS Measured power (dBµV)	86.22	87.42	87.50	86.49	86.01	85.39	84.32	84.29	84.20	83.10	83.60	82.32
Delta (dB)	-1.69	0.20	0.49	-0.49	-0.39	-0.93	-1.66	-0.91	-0.10	-0.70	0.64	-0.23

Frequency (MHz)	0.30	0.40	0.50	0.60	0.70	0.80	0.90	1.00	2.00	3.00	4.00	5.00
SR1 Measured power (dBµV)	81.98	81.23	80.39	80.00	79.53	79.10	78.87	78.20	77.60	77.01	76.32	76.04
OATS Measured power (dBµV)	80.84	80.49	79.58	79.58	78.85	78.59	77.69	77.50	77.91	76.90	75.45	74.90
Delta (dB)	-1.14	-0.74	-0.81	-0.42	-0.68	-0.51	-1.18	-0.70	0.31	-0.11	-0.87	-1.14

Frequency (MHz)	6.00	7.00	8.00	9.00	10.00	11.00	12.00	13.00	13.56	14.00	15.00	16.00
SR1 Measured power (dBµV)	75.98	75.43	75.20	74.97	74.59	74.32	74.05	73.83	73.50	73.22	73.20	73.05
OATS Measured power (dBµV)	74.94	74.09	74.11	73.58	73.87	74.38	74.84	74.31	74.88	74.29	73.90	73.93
Delta (dB)	-1.04	-1.34	-1.09	-1.39	-0.72	0.06	0.79	0.48	1.38	1.07	0.70	0.88

Frequency (MHz)	17.00	18.00	19.00	20.00	21.00	22.00	23.00	24.00	25.00	26.00	27.00	28.00	29.00	30.00
SR1 Measured power (dBµV)	73.00	72.86	72.74	72.64	72.50	72.52	72.39	72.20	72.04	71.97	71.86	71.64	71.41	71.27
OATS Measured power (dBµV)	73.70	73.98	72.90	72.60	72.45	72.34	72.59	72.59	71.97	71.59	71.58	71.88	71.98	72.49
Delta (dB)	0.70	1.12	0.16	-0.04	-0.05	-0.18	0.20	0.39	-0.07	-0.38	-0.28	0.24	0.57	1.22

Graph

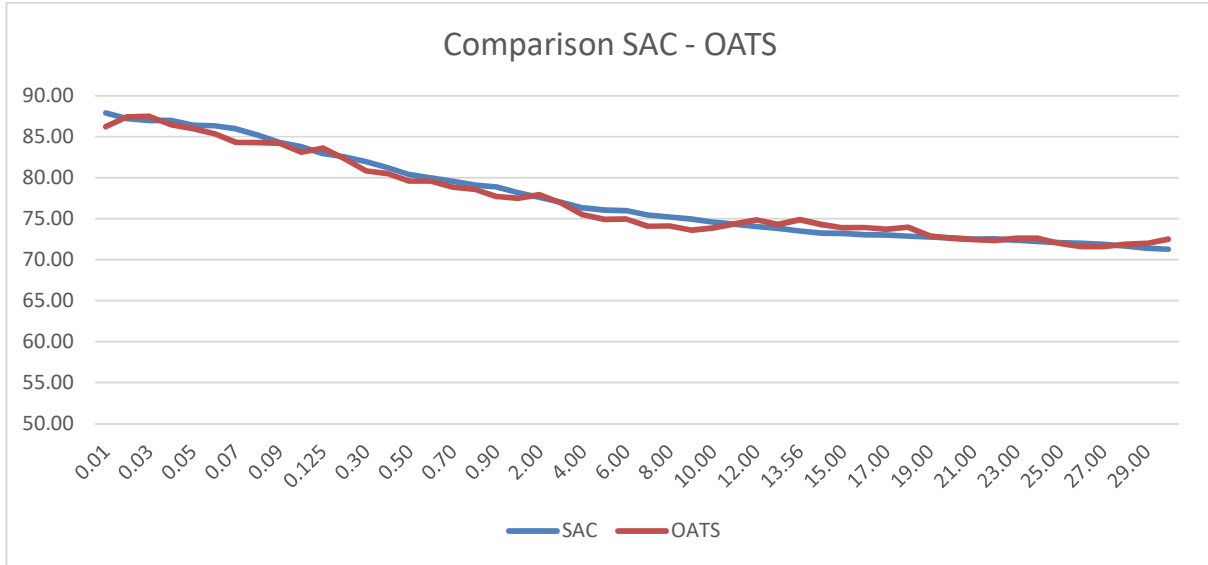

Conclusion: Maximum difference is 1.69 dB @ 9 kHz

9. Report Revision History

Version Number	Revision Details		
	Page No(s)	Clause	Details
1.0	33	-	Initial Version
1.1	39		Administrative references changed Frequency error re-measured with temperature range from -20 degrees to +50 degrees Corrected calibration dates Detailed notes added to AC conducted Specified comparison between OATS and SAC