

FCC Test Report

Report No.: RF170726C40

FCC ID: 2AMRF-FCM9000N

Test Model: FCM9000P-100 , FCM9000E-100 (Refer to section 3.1 for more details)

Received Date: Jul. 26, 2017

Test Date: Aug. 10, 2017 ~ Aug. 23, 2017

Issued Date: Sep. 04, 2017

Applicant: FCI Inc.

Address: 7F, Bld B, SiliconPark, 35, Pangyo-ro 255 beon-gil(Sampyeong-dong),
Bundang-gu, Seongnam-si, Gyeonggi-do KOREA (13486)

Issued By: Bureau Veritas Consumer Products Services (H.K.) Ltd., Taoyuan Branch

Lab Address: No. 47-2, 14th Ling, Chia Pau Vil., Lin Kou Dist., New Taipei City, Taiwan
(R.O.C)

Test Location: No.19, Hwa Ya 2nd Rd., Wen Hwa Vil., Kwei Shan Dist., Taoyuan City
33383, Taiwan, R.O.C



This report is for your exclusive use. Any copying or replication of this report to or for any other person or entity, or use of our name or trademark, is permitted only with our prior written permission. This report sets forth our findings solely with respect to the test samples identified herein. The results set forth in this report are not indicative or representative of the quality or characteristics of the lot from which a test sample was taken or any similar or identical product unless specifically and expressly noted. Our report includes all of the tests requested by you and the results thereof based upon the information that you provided to us. You have 60 days from date of issuance of this report to notify us of any material error or omission caused by our negligence, provided, however, that such notice shall be in writing and shall specifically address the issue you wish to raise. A failure to raise such issue within the prescribed time shall constitute your unqualified acceptance of the completeness of this report, the tests conducted and the correctness of the report contents. Unless specific mention, the uncertainty of measurement has been explicitly taken into account to declare the compliance or non-compliance to the specification.

Table of Contents

Release Control Record	4
1 Certificate of Conformity	5
2 Summary of Test Results	6
2.1 Measurement Uncertainty	6
2.2 Modification Record	6
3 General Information	7
3.1 General Description of EUT	7
3.2 Description of Test Modes	8
3.2.1 Test Mode Applicability and Tested Channel Detail	9
3.3 Duty Cycle of Test Signal	11
3.4 Description of Support Units	13
3.4.1 Configuration of System under Test	13
3.5 General Description of Applied Standards	14
4 Test Types and Results	15
4.1 Radiated Emission and Bandedge Measurement	15
4.1.1 Limits of Radiated Emission and Bandedge Measurement	15
4.1.2 Test Instruments	16
4.1.3 Test Procedures	17
4.1.4 Deviation from Test Standard	17
4.1.5 Test Set Up	18
4.1.6 EUT Operating Conditions	18
4.1.7 Test Results	19
4.2 Conducted Emission Measurement	39
4.2.1 Limits of Conducted Emission Measurement	39
4.2.2 Test Instruments	39
4.2.3 Test Procedures	40
4.2.4 Deviation from Test Standard	40
4.2.5 Test Setup	40
4.2.6 EUT Operating Conditions	40
4.2.7 Test Results	41
4.3 6 dB Bandwidth Measurement	45
4.3.1 Limits of 6 dB Bandwidth Measurement	45
4.3.2 Test Setup	45
4.3.3 Test Instruments	45
4.3.4 Test Procedure	45
4.3.5 Deviation from Test Standard	45
4.3.6 EUT Operating Conditions	45
4.3.7 Test Result	46
4.4 Conducted Output Power Measurement	50
4.4.1 Limits of Conducted Output Power Measurement	50
4.4.2 Test Setup	50
4.4.3 Test Instruments	50
4.4.4 Test Procedures	50
4.4.5 Deviation from Test Standard	50
4.4.6 EUT Operating Conditions	50
4.4.7 Test Results	51
4.5 Power Spectral Density Measurement	53
4.5.1 Limits of Power Spectral Density Measurement	53
4.5.2 Test Setup	53
4.5.3 Test Instruments	53
4.5.4 Test Procedure	53
4.5.5 Deviation from Test Standard	53
4.5.6 EUT Operating Condition	53

4.5.7 Test Results	54
4.6 Conducted Out of Band Emission Measurement	58
4.6.1 Limits of Conducted Out of Band Emission Measurement.....	58
4.6.2 Test Setup.....	58
4.6.3 Test Instruments	58
4.6.4 Test Procedure	58
4.6.5 Deviation from Test Standard	58
4.6.6 EUT Operating Condition	58
4.6.7 Test Results	59
5 Pictures of Test Arrangements.....	71
Appendix – Information on the Testing Laboratories	72

Release Control Record

Issue No.	Description	Date Issued
RF170726C40	Original Release	Sep. 04, 2017

1 Certificate of Conformity

Product: FC9000 Module

Brand: FCI

Test Model: FCM9000P-100 , FCM9000E-100 (Refer to section 3.1 for more details)

Sample Status: Production Unit

Applicant: FCI Inc.

Test Date: Aug. 10, 2017 ~ Aug. 23, 2017

Standards: 47 CFR FCC Part 15, Subpart C (Section 15.247)
ANSI C63.10:2013

The above equipment has been tested by **Bureau Veritas Consumer Products Services (H.K.) Ltd., Taoyuan Branch**, and found compliance with the requirement of the above standards. The test record, data evaluation & Equipment Under Test (EUT) configurations represented herein are true and accurate accounts of the measurements of the sample's EMC characteristics under the conditions specified in this report.

Prepared by :

Rona Chen

,

Date:

Sep. 04, 2017

Rona Chen / Specialist

Approved by :

David Huang

,

Date:

Sep. 04, 2017

David Huang / Project Engineer

2 Summary of Test Results

47 CFR FCC Part 15, Subpart C (Section 15.247)			
FCC Clause	Test Item	Result	Remarks
15.207	AC Power Conducted Emission	Pass	Meet the requirement of limit. Minimum passing margin is -10.38 dB at 0.17338 MHz.
15.205 / 15.209 / 15.247(d)	Radiated Emissions and Band Edge Measurement	Pass	Meet the requirement of limit. Minimum passing margin is -1.16 dB at 2389.92 MHz and 4824 MHz.
15.247(d)	Antenna Port Emission	Pass	Meet the requirement of limit.
15.247(a)(2)	6 dB Bandwidth	Pass	Meet the requirement of limit.
15.247(b)	Conducted power	Pass	Meet the requirement of limit.
15.247(e)	Power Spectral Density	Pass	Meet the requirement of limit.
15.203	Antenna Requirement	Pass	FCM9000P-100: No antenna connector is used. FCM9000E-100: Antenna connector is UFL-R-SMA type.

2.1 Measurement Uncertainty

Where relevant, the following measurement uncertainty levels have been estimated for tests performed on the EUT:

The listed uncertainties are the worst case uncertainty for the entire range of measurement. Please note that the uncertainty values are provided for informational purposes only and are not used in determining the PASS/FAIL results.

Measurement	Frequency	Expanded Uncertainty (k=2) (±)
Conducted Emissions at mains ports	150 kHz ~ 30 MHz	2.44 dB
Radiated Emissions up to 1 GHz	30 MHz ~ 200 MHz	2.93 dB
	200 MHz ~ 1000 MHz	2.95 dB
Radiated Emissions above 1 GHz	1 GHz ~ 18 GHz	2.26 dB
	18 GHz ~ 40 GHz	1.94 dB

2.2 Modification Record

There were no modifications required for compliance.

3 General Information

3.1 General Description of EUT

Product	FC9000 Module
Brand	FCI
Test Model	FCM9000P-100 , FCM9000E-100
Status of EUT	Production Unit
Power Supply Rating	3.3 Vdc (Host equipment)
Modulation Type	CCK, DQPSK, DBPSK for DSSS 64QAM, 16QAM, QPSK, BPSK for OFDM
Modulation Technology	DSSS, OFDM
Transfer Rate	802.11b: 11.0 / 5.5 / 2.0 / 1.0 Mbps 802.11g: 54.0 / 48.0 / 36.0 / 24.0 / 18.0 / 12.0 / 9.0 / 6.0 Mbps 802.11n: up to MCS7
Operating Frequency	2412 ~ 2462 MHz
Number of Channel	11 for 802.11b, 802.11g, 802.11n (HT20)
Output Power	184.502 mW
Antenna Type	Refer to Note as below
Antenna Connector	N/A
Accessory Device	Refer to Note as below
Data Cable Supplied	Refer to Note as below

Note:

- All models are listed as below.

Sample	Brand	Model	Difference	Antenna Gain
A	FCI	FCM9000P-100	PCB pattern antenna type	0.5 dBi
B		FCM9000E-100	External antenna type	2.5 dBi

- The EUT incorporates a MIMO function. Physically, the EUT provides two completed transmitters and two receivers.

Modulation Mode	Tx Function
802.11b	1TX
802.11g	1TX
802.11n (HT20)	1TX

- The above EUT information is declared by manufacturer and for more detailed features description, please refer to the manufacturer's specifications or user's manual.

3.2 Description of Test Modes

11 channels are provided for 802.11b, 802.11g and 802.11n (HT20):

Channel	Frequency (MHz)	Channel	Frequency (MHz)
1	2412	7	2442
2	2417	8	2447
3	2422	9	2452
4	2427	10	2457
5	2432	11	2462
6	2437		

3.2.1 Test Mode Applicability and Tested Channel Detail

EUT Configure Mode	Applicable To				Description
	RE \geq 1G	RE<1G	PLC	APCM	
A	√	√	√	√	Sample A (PCB pattern antenna)
B	√	√	√	√	Sample B (External antenna)

Where **RE \geq 1G**: Radiated Emission above 1 GHz **RE<1G**: Radiated Emission below 1 GHz
PLC: Power Line Conducted Emission **APCM**: Antenna Port Conducted Measurement

NOTE: The EUT had been pre-tested on the positioned of each 3 axis. The worst case was found when positioned on **X-plane**.

Radiated Emission Test (Above 1 GHz):

- Pre-Scan has been conducted to determine the worst-case mode from all possible combinations between available modulations, data rates and antenna ports (if EUT with antenna diversity architecture).
- Following channel(s) was (were) selected for the final test as listed below.

EUT Configure Mode	Mode	Available Channel	Tested Channel	Modulation Technology	Modulation Type	Data Rate (Mbps)
A, B	802.11b	1 to 11	1, 6, 11	DSSS	DBPSK	1.0
	802.11g	1 to 11	1, 6, 11	OFDM	BPSK	6.0
	802.11n (HT20)	1 to 11	1, 6, 11	OFDM	BPSK	MCS0

Radiated Emission Test (Below 1 GHz):

- Pre-Scan has been conducted to determine the worst-case mode from all possible combinations between available modulations, data rates and antenna ports (if EUT with antenna diversity architecture).
- Following channel(s) was (were) selected for the final test as listed below.

EUT Configure Mode	Mode	Available Channel	Tested Channel	Modulation Technology	Modulation Type	Data Rate (Mbps)
A	802.11g	1 to 11	1	OFDM	BPSK	6.0
B	802.11b	1 to 11	1	DSSS	DBPSK	1.0

Power Line Conducted Emission Test:

- Pre-Scan has been conducted to determine the worst-case mode from all possible combinations between available modulations, data rates and antenna ports (if EUT with antenna diversity architecture).
- Following channel(s) was (were) selected for the final test as listed below.

EUT Configure Mode	Mode	Available Channel	Tested Channel	Modulation Technology	Modulation Type	Data Rate (Mbps)
A	802.11g	1 to 11	1	OFDM	BPSK	6.0
B	802.11b	1 to 11	1	DSSS	DBPSK	1.0

Bandedge Measurement:

- Pre-Scan has been conducted to determine the worst-case mode from all possible combinations between available modulations, data rates and antenna ports (if EUT with antenna diversity architecture).
- Following channel(s) was (were) selected for the final test as listed below.

EUT Configure Mode	Mode	Available Channel	Tested Channel	Modulation Technology	Modulation Type	Data Rate (Mbps)
A, B	802.11b	1 to 11	1, 11	DSSS	DBPSK	1.0
	802.11g	1 to 11	1, 11	OFDM	BPSK	6.0
	802.11n (HT20)	1 to 11	1, 11	OFDM	BPSK	MCS0

Antenna Port Conducted Measurement:

- This item includes all test value of each mode, but only includes spectrum plot of worst value of each mode.
- Pre-Scan has been conducted to determine the worst-case mode from all possible combinations between available modulations, data rates and antenna ports (if EUT with antenna diversity architecture).
- Following channel(s) was (were) selected for the final test as listed below.

EUT Configure Mode	Mode	Available Channel	Tested Channel	Modulation Technology	Modulation Type	Data Rate (Mbps)
A, B	802.11b	1 to 11	1, 6, 11	DSSS	DBPSK	1.0
	802.11g	1 to 11	1, 6, 11	OFDM	BPSK	6.0
	802.11n (HT20)	1 to 11	1, 6, 11	OFDM	BPSK	MCS0

Test Condition:

Applicable To	Environmental Conditions	Input Power	Tested by
RE \geq 1G	25 deg. C, 65 % RH	120 Vac, 60 Hz	Gavin Wu
RE $<$ 1G	25 deg. C, 65 % RH	120 Vac, 60 Hz	Gavin Wu
PLC	25 deg. C, 65 % RH	120 Vac, 60 Hz	Han Wu
APCM	25 deg. C, 65 % RH	3.3 Vdc	Carlos Chen

3.3 Duty Cycle of Test Signal

Mode A

802.11b: Duty cycle of test signal is 100 %, duty factor is not required.

802.11g: Duty cycle = $0.160/0.202 = 0.792$, Duty factor = $10 * \log(1/0.792) = 1.01$

802.11n (HT20): Duty cycle = $0.167/0.205 = 0.815$, Duty factor = $10 * \log(1/0.815) = 0.89$

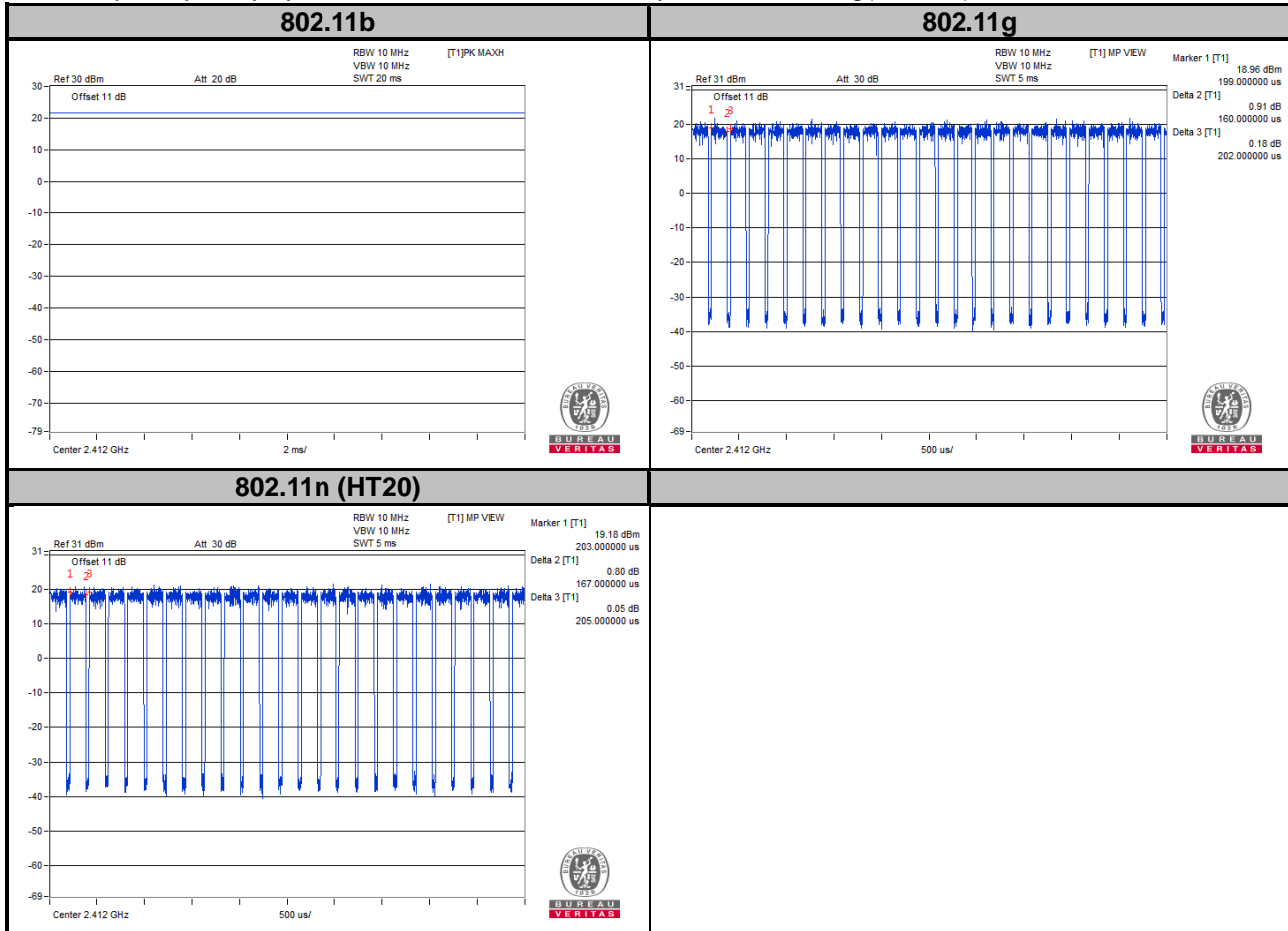

Mode B

802.11b: Duty cycle of test signal is 100 %, duty factor is not required.

802.11g: Duty cycle = $0.160/0.202 = 0.792$, Duty factor = $10 * \log(1/0.792) = 1.01$

802.11n (HT20): Duty cycle = $0.167/0.205 = 0.815$, Duty factor = $10 * \log(1/0.815) = 0.89$

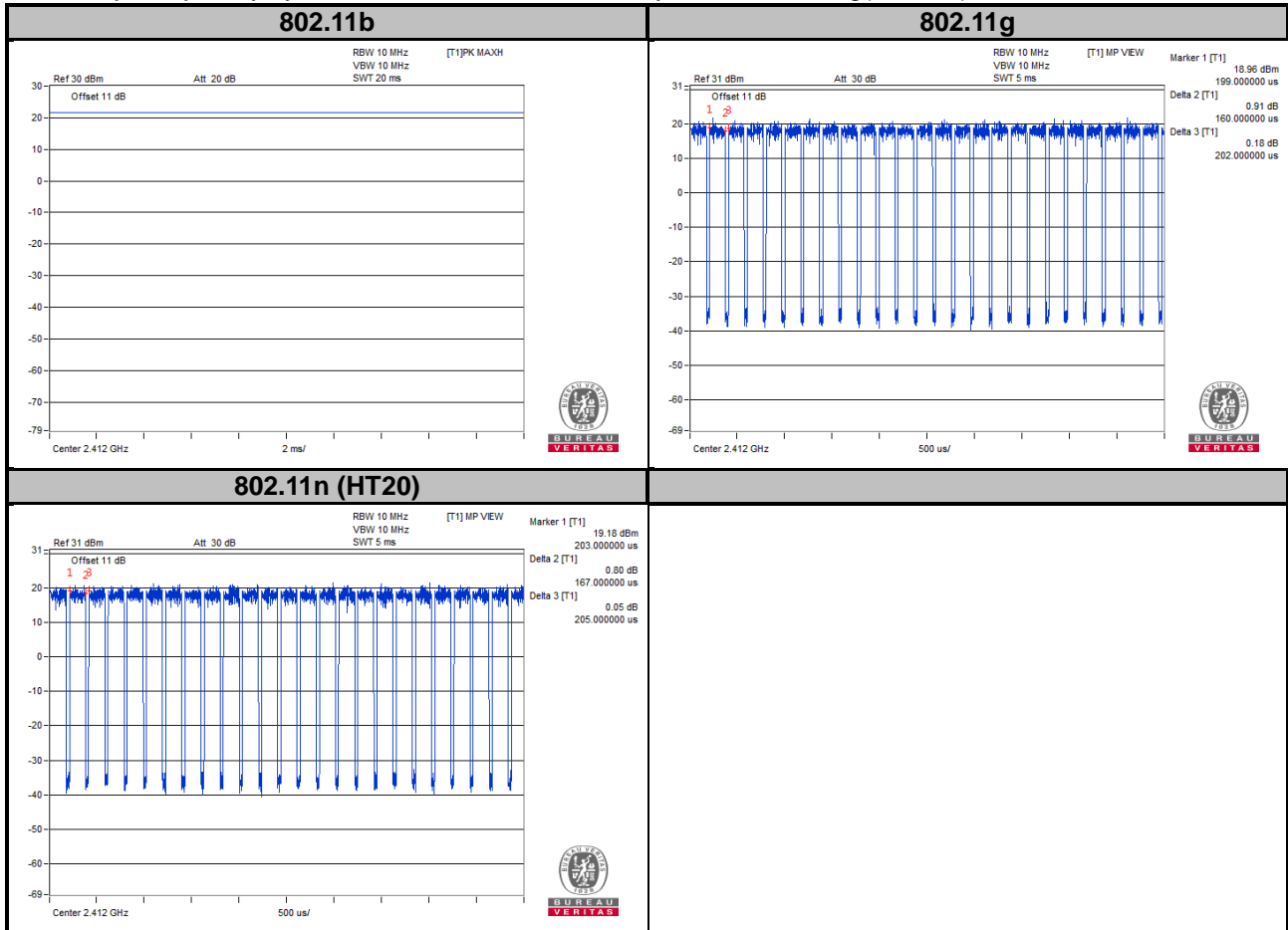

3.4 Description of Support Units

The EUT has been tested as an independent unit together with other necessary accessories or support units. The following support units or accessories were used to form a representative test configuration during the tests.

No.	Product	Brand	Model No.	Serial No.	FCC ID
1.	Notebook	DELL	Inspiron 14R	8LRKKW1	N/A
2.	External Antenna	N/A	TE-2450TO-03-105	N/A	N/A

No.	Signal Cable Description Of The Above Support Units
1.	N/A
2.	N/A

Note:

1. All power cords of the above support units are non-shielded (1.8m).
2. Item 2 was provided by client.

3.4.1 Configuration of System under Test

Mode A

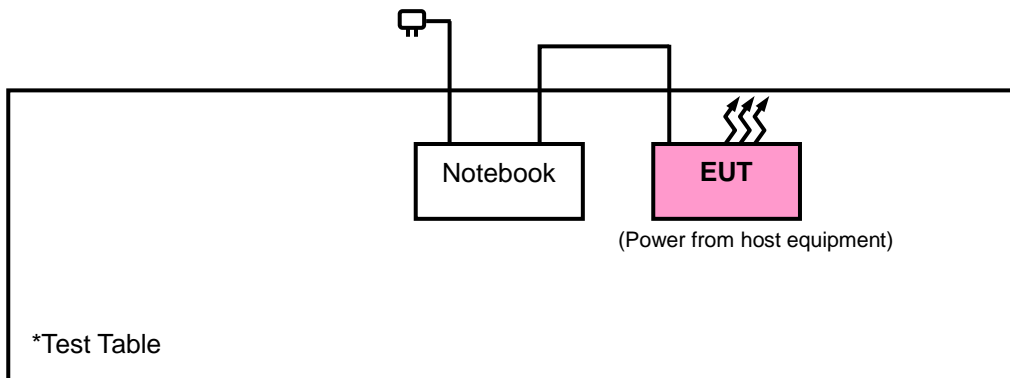

Mode B

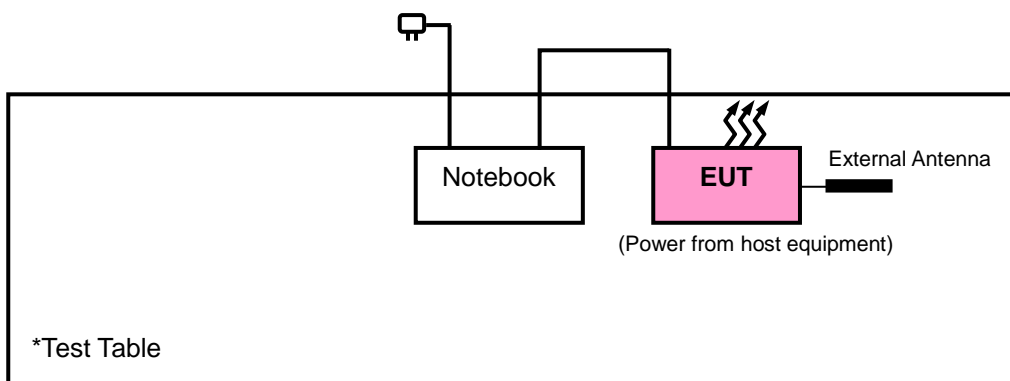

3.5 General Description of Applied Standards

The EUT is a RF Product. According to the specifications of the manufacturer, it must comply with the requirements of the following standards:

FCC Part 15, Subpart C (15.247)

558074 D01 DTS Meas Guidance v04

ANSI C63.10-2013

All test items have been performed and recorded as per the above standards.

NOTE: The EUT has been verified to comply with the requirements of FCC Part 15, Subpart B, Class B (DoC).
The test report has been issued separately.

4 Test Types and Results

4.1 Radiated Emission and Bandedge Measurement

4.1.1 Limits of Radiated Emission and Bandedge Measurement

Radiated emissions which fall in the restricted bands must comply with the radiated emission limits specified as below table. Other emissions shall be at least 20 dB below the highest level of the desired power:

Frequencies (MHz)	Field Strength (microvolts/meter)	Measurement Distance (meters)
0.009 ~ 0.490	2400/F (kHz)	300
0.490 ~ 1.705	24000/F (kHz)	30
1.705 ~ 30.0	30	30
30 ~ 88	100	3
88 ~ 216	150	3
216 ~ 960	200	3
Above 960	500	3

NOTE:

1. The lower limit shall apply at the transition frequencies.
2. Emission level (dBuV/m) = 20 log Emission level (uV/m).
3. For frequencies above 1000 MHz, the field strength limits are based on average detector, however, the peak field strength of any emission shall not exceed the maximum permitted average limits, specified above by more than 20 dB under any condition of modulation.

4.1.2 Test Instruments

Description & Manufacturer	Model No.	Serial No.	Date of Calibration	Due Date of Calibration
Test Receiver Agilent	N9038A	MY51210203	Feb. 17, 2017	Feb. 16, 2018
Spectrum Analyzer Agilent	N9010A	MY52220314	Dec. 16, 2016	Dec. 15, 2017
Spectrum Analyzer ROHDE & SCHWARZ	FSU43	101261	Dec. 13, 2016	Dec. 12, 2017
BILOG Antenna SCHWARZBECK	VULB9168	9168-472	Dec. 26, 2016	Dec. 27, 2017
HORN Antenna SCHWARZBECK	BBHA 9120 D	9120D-969	Dec. 12, 2016	Dec. 13, 2017
HORN Antenna SCHWARZBECK	BBHA 9170	9170-480	Dec. 14, 2016	Dec. 13, 2017
Fixed Attenuator Woken	MDCS18N-10	MDCS18N-10-01	Apr. 17, 2017	Apr. 16, 2018
Loop Antenna TESEQ	HLA 6121	45745	May 19, 2017	May 18, 2018
Preamplifier EMCI	EMC 012645	980115	Oct. 21, 2016	Oct. 20, 2017
Preamplifier EMCI	EMC 184045	980116	Oct. 21, 2016	Oct. 20, 2017
Preamplifier EMCI	EMC 330H	980112	Oct. 21, 2016	Oct. 20, 2017
Power Meter Anritsu	ML2495A	1232002	Sep. 08, 2016	Sep. 07, 2017
Power Sensor Anritsu	MA2411B	1207325	Sep. 08, 2016	Sep. 07, 2017
RF signal cable HUBER+SUHNNER	SUCOFLEX 104	309219/4 2950114	Oct. 21, 2016	Oct. 20, 2017
RF signal cable HUBER+SUHNNER	SUCOFLEX 104	250130/4	Oct. 21, 2016	Oct. 20, 2017
RF Coaxial Cable Worken	8D-FB	Cable-Ch10-01	Oct. 21, 2016	Oct. 20, 2017
Software BV ADT	E3 6.120103	NA	NA	NA
Antenna Tower MF	MFA-440H	NA	NA	NA
Turn Table MF	MFT-201SS	NA	NA	NA
Antenna Tower & Turn Table Controller MF	MF-7802	NA	NA	NA

- Note: 1. The calibration interval of the above test instruments is 12 months and the calibrations are traceable to NML/ROC and NIST/USA.
2. The test was performed in HwaYa Chamber 10.
3. The horn antenna and preamplifier (model: EMC 184045) are used only for the measurement of emission frequency above 1 GHz if tested.
4. The FCC Designation Number is TW0003. The number will be varied with the Lab location and scope as attached.
5. The IC Site Registration No. is IC7450F-10.

4.1.3 Test Procedures

- a. The EUT was placed on the top of a rotating table 0.8 meters (for below 1 GHz) / 1.5 meters (for above 1 GHz) above the ground at 3 meter chamber room for test. The table was rotated 360 degrees to determine the position of the highest radiation.
- b. The EUT was set 3 meters away from the interference-receiving antenna, which was mounted on the top of a variable-height antenna tower.
- c. The height of antenna is varied from one meter to four meters above the ground to determine the maximum value of the field strength. Both horizontal and vertical polarizations of the antenna are set to make the measurement.
- d. For each suspected emission, the EUT was arranged to its worst case and then the antenna was tuned to heights from 1 meter to 4 meters and the rotatable table was turned from 0 degrees to 360 degrees to find the maximum reading.
- e. The test-receiver system was set to quasi-peak detect function and specified bandwidth with maximum hold mode when the test frequency is below 1 GHz.
- f. The test-receiver system was set to peak and average detected function and specified bandwidth with maximum hold mode when the test frequency is above 1 GHz. If the peak reading value also meets average limit, measurement with the average detector is unnecessary.

Note:

1. The resolution bandwidth and video bandwidth of test receiver/spectrum analyzer is 120 kHz & 360 KHz for Quasi-peak detection (QP) at frequency below 1 GHz.
2. The resolution bandwidth of test receiver/spectrum analyzer is 1 MHz and the video bandwidth is 3 MHz for Peak detection (PK) at frequency above 1 GHz.
3. The resolution bandwidth of test receiver/spectrum analyzer is 1 MHz and the video bandwidth is 1/T for Average (Duty cycle < 98 %) detection at frequency above 1 GHz.
4. The resolution bandwidth of test receiver/spectrum analyzer is 1 MHz and the video bandwidth is 10 Hz (Duty cycle \geq 98 %) for Average detection (AV) at frequency above 1 GHz.
5. All modes of operation were investigated and the worst-case emissions are reported.

4.1.4 Deviation from Test Standard

No deviation.

4.1.5 Test Set Up

<Frequency Range below 1 GHz>

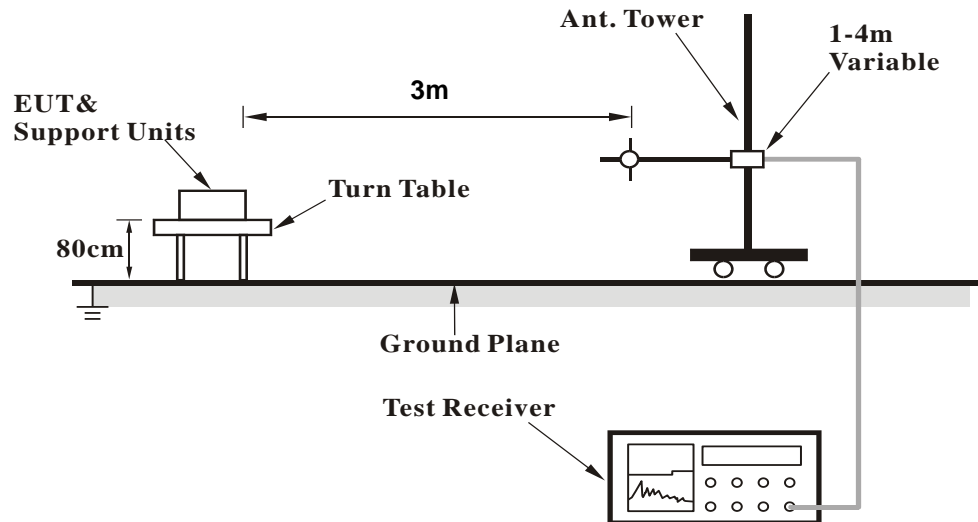

<Frequency Range above 1 GHz>

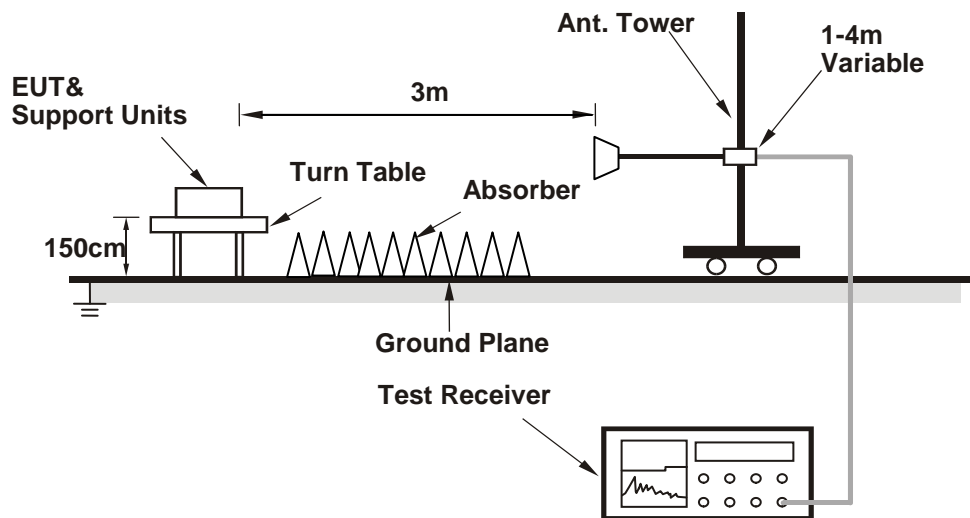

For the actual test configuration, please refer to the attached file (Test Setup Photo).

4.1.6 EUT Operating Conditions

- Placed the EUT on a testing table.
- Use the software to control the EUT under transmission condition continuously at specific channel frequency.

4.1.7 Test Results

Above 1 GHz Data :

Mode A

802.11b

EUT Test Condition		Measurement Detail	
Channel	Channel 1	Frequency Range	1 GHz ~ 25 GHz
Input Power	120 Vac, 60 Hz	Detector Function	Peak (PK) Average (AV)
Environmental Conditions	25 deg. C, 65 % RH	Tested By	Gavin Wu

Antennal Polarity & Test Distance: Horizontal at 3 m										
Frequency (MHz)	Emission Level (dBuV/m)	Read Level (dBuV)	Limit (dBuV/m)	Margin (dB)	Antenna Factor (dB/m)	Cable Loss (dB)	Preamp Factor (dB)	Antenna Height (cm)	Table Angle (Degree)	Remark
2389.29	41.35	47.58	54	-12.65	26.91	4.36	37.5	237	282	Average
2389.29	52.92	59.15	74	-21.08	26.91	4.36	37.5	237	282	Peak
2412	103.17	109.35			26.96	4.38	37.52	237	282	Average
2412	109.62	115.8			26.96	4.38	37.52	237	282	Peak
4824	48.71	63.8	54	-5.29	30.99	6.81	52.89	113	96	Average
4824	50.79	65.88	74	-23.21	30.99	6.81	52.89	113	96	Peak
Antennal Polarity & Test Distance: Vertical at 3 m										
Frequency (MHz)	Emission Level (dBuV/m)	Read Level (dBuV)	Limit (dBuV/m)	Margin (dB)	Antenna Factor (dB/m)	Cable Loss (dB)	Preamp Factor (dB)	Antenna Height (cm)	Table Angle (Degree)	Remark
2314.41	54.88	61.4	74	-19.12	26.67	4.28	37.47	172	350	Peak
2389.92	36.42	42.67	54	-17.58	26.91	4.36	37.52	172	350	Average
2412	94.93	101.11			26.96	4.38	37.52	172	350	Average
2412	100.53	106.71			26.96	4.38	37.52	172	350	Peak
4824	49.31	64.59	54	-4.69	30.99	6.81	53.08	142	260	Average
4824	51.09	66.37	74	-22.91	30.99	6.81	53.08	142	260	Peak

Remarks:

- Emission Level = Read Level + Antenna Factor + Cable Loss - Preamp Factor
Margin value = Emission level – Limit value
- 2412 MHz: Fundamental frequency.

EUT Test Condition		Measurement Detail	
Channel	Channel 6	Frequency Range	1 GHz ~ 25 GHz
Input Power	120 Vac, 60 Hz	Detector Function	Peak (PK) Average (AV)
Environmental Conditions	25 deg. C, 65 % RH	Tested By	Gavin Wu

Antennal Polarity & Test Distance: Horizontal at 3 m										
Frequency (MHz)	Emission Level (dBuV/m)	Read Level (dBuV)	Limit (dBuV/m)	Margin (dB)	Antenna Factor (dB/m)	Cable Loss (dB)	Preamp Factor (dB)	Antenna Height (cm)	Table Angle (Degree)	Remark
2385.69	48.42	54.66	74	-25.58	26.91	4.35	37.5	263	275	Peak
2388.93	36.3	42.53	54	-17.7	26.91	4.36	37.5	263	275	Average
2437	103.02	109.02			27.06	4.4	37.46	263	275	Average
2437	107.43	113.43			27.06	4.4	37.46	263	275	Peak
2484.72	35.73	41.47	54	-18.27	27.15	4.43	37.32	263	275	Average
2486.16	47.96	53.7	74	-26.04	27.15	4.43	37.32	263	275	Peak
4874	47.49	62.43	54	-6.51	31.06	6.86	52.86	158	355	Average
4874	48.84	63.78	74	-25.16	31.06	6.86	52.86	158	355	Peak
Antennal Polarity & Test Distance: Vertical at 3 m										
Frequency (MHz)	Emission Level (dBuV/m)	Read Level (dBuV)	Limit (dBuV/m)	Margin (dB)	Antenna Factor (dB/m)	Cable Loss (dB)	Preamp Factor (dB)	Antenna Height (cm)	Table Angle (Degree)	Remark
2327.91	36.66	43.12	54	-17.34	26.72	4.29	37.47	222	30	Average
2336.01	49.49	55.89	74	-24.51	26.77	4.3	37.47	222	30	Peak
2437	92.48	98.48			27.06	4.4	37.46	222	30	Average
2437	100.05	106.05			27.06	4.4	37.46	222	30	Peak
2489.48	47.5	53.19	74	-26.5	27.2	4.43	37.32	222	30	Peak
2492.48	35.62	41.24	54	-18.38	27.2	4.43	37.25	222	30	Average
4874	48.69	63.82	54	-5.31	31.06	6.86	53.05	169	21	Average
4874	51.26	66.39	74	-22.74	31.06	6.86	53.05	169	21	Peak

Remarks:

- Emission Level = Read Level + Antenna Factor + Cable Loss - Preamp Factor
Margin value = Emission level – Limit value
- 2437 MHz: Fundamental frequency.

EUT Test Condition		Measurement Detail	
Channel	Channel 11	Frequency Range	1 GHz ~ 25 GHz
Input Power	120 Vac, 60 Hz	Detector Function	Peak (PK) Average (AV)
Environmental Conditions	25 deg. C, 65 % RH	Tested By	Gavin Wu

Antennal Polarity & Test Distance: Horizontal at 3 m										
Frequency (MHz)	Emission Level (dBuV/m)	Read Level (dBuV)	Limit (dBuV/m)	Margin (dB)	Antenna Factor (dB/m)	Cable Loss (dB)	Preamp Factor (dB)	Antenna Height (cm)	Table Angle (Degree)	Remark
2462	102.56	108.44			27.1	4.41	37.39	284	281	Average
2462	107.08	112.96			27.1	4.41	37.39	284	281	Peak
2483.52	36.87	42.61	54	-17.13	27.15	4.43	37.32	284	281	Average
2484.08	49.74	55.48	74	-24.26	27.15	4.43	37.32	284	281	Peak
4924	43.66	58.54	54	-10.34	31.12	6.89	52.89	137	121	Average
4924	48.24	63.12	74	-25.76	31.12	6.89	52.89	137	121	Peak

Antennal Polarity & Test Distance: Vertical at 3 m										
Frequency (MHz)	Emission Level (dBuV/m)	Read Level (dBuV)	Limit (dBuV/m)	Margin (dB)	Antenna Factor (dB/m)	Cable Loss (dB)	Preamp Factor (dB)	Antenna Height (cm)	Table Angle (Degree)	Remark
2462	93.56	99.44			27.1	4.41	37.39	218	30	Average
2462	100.78	106.66			27.1	4.41	37.39	218	30	Peak
2488.8	47.78	53.47	74	-26.22	27.2	4.43	37.32	218	30	Peak
2490.72	35.76	41.45	54	-18.24	27.2	4.43	37.32	218	30	Average
4924	48.12	63.14	54	-5.88	31.12	6.89	53.03	182	34	Average
4924	50.74	65.76	74	-23.26	31.12	6.89	53.03	182	34	Peak

Remarks:

- Emission Level = Read Level + Antenna Factor + Cable Loss - Preamp Factor
Margin value = Emission level – Limit value
- 2462 MHz: Fundamental frequency.

802.11g

EUT Test Condition		Measurement Detail	
Channel	Channel 1	Frequency Range	1 GHz ~ 25 GHz
Input Power	120 Vac, 60 Hz	Detector Function	Peak (PK) Average (AV)
Environmental Conditions	25 deg. C, 65 % RH	Tested By	Gavin Wu

Antennal Polarity & Test Distance: Horizontal at 3 m

Frequency (MHz)	Emission Level (dBuV/m)	Read Level (dBuV)	Limit (dBuV/m)	Margin (dB)	Antenna Factor (dB/m)	Cable Loss (dB)	Preamp Factor (dB)	Antenna Height (cm)	Table Angle (Degree)	Remark
2389.47	70.67	76.9	74	-3.33	26.91	4.36	37.5	176	290	Peak
2389.92	52.84	59.09	54	-1.16	26.91	4.36	37.52	176	290	Average
2412	100.67	106.85			26.96	4.38	37.52	176	290	Average
2412	109.42	115.6			26.96	4.38	37.52	176	290	Peak
4824	34.17	49.26	54	-19.83	30.99	6.81	52.89	103	177	Average
4824	47.16	62.25	74	-26.84	30.99	6.81	52.89	103	177	Peak

Antennal Polarity & Test Distance: Vertical at 3 m

Frequency (MHz)	Emission Level (dBuV/m)	Read Level (dBuV)	Limit (dBuV/m)	Margin (dB)	Antenna Factor (dB/m)	Cable Loss (dB)	Preamp Factor (dB)	Antenna Height (cm)	Table Angle (Degree)	Remark
2389.83	62.21	68.46	74	-11.79	26.91	4.36	37.52	218	346	Peak
2389.92	44.79	51.04	54	-9.21	26.91	4.36	37.52	218	346	Average
2412	91.45	97.63			26.96	4.38	37.52	218	346	Average
2412	100.25	106.43			26.96	4.38	37.52	218	346	Peak
4824	35.23	50.51	54	-18.77	30.99	6.81	53.08	105	169	Average
4824	47.24	62.52	74	-26.76	30.99	6.81	53.08	105	169	Peak

Remarks:

- Emission Level = Read Level + Antenna Factor + Cable Loss - Preamp Factor
Margin value = Emission level – Limit value
- 2412 MHz: Fundamental frequency.

EUT Test Condition		Measurement Detail	
Channel	Channel 6	Frequency Range	1 GHz ~ 25 GHz
Input Power	120 Vac, 60 Hz	Detector Function	Peak (PK) Average (AV)
Environmental Conditions	25 deg. C, 65 % RH	Tested By	Gavin Wu

Antennal Polarity & Test Distance: Horizontal at 3 m										
Frequency (MHz)	Emission Level (dBuV/m)	Read Level (dBuV)	Limit (dBuV/m)	Margin (dB)	Antenna Factor (dB/m)	Cable Loss (dB)	Preamp Factor (dB)	Antenna Height (cm)	Table Angle (Degree)	Remark
2387.49	54.21	60.44	74	-19.79	26.91	4.36	37.5	174	280	Peak
2388.66	38.3	44.53	54	-15.7	26.91	4.36	37.5	174	280	Average
2437	100.68	106.68			27.06	4.4	37.46	174	280	Average
2437	110.16	116.16			27.06	4.4	37.46	174	280	Peak
2484.76	37.07	42.81	54	-16.93	27.15	4.43	37.32	174	280	Average
2485.48	48.85	54.59	74	-25.15	27.15	4.43	37.32	174	280	Peak
4874	34.27	49.21	54	-19.73	31.06	6.86	52.86	103	111	Average
4874	45.37	60.31	74	-28.63	31.06	6.86	52.86	103	111	Peak
Antennal Polarity & Test Distance: Vertical at 3 m										
Frequency (MHz)	Emission Level (dBuV/m)	Read Level (dBuV)	Limit (dBuV/m)	Margin (dB)	Antenna Factor (dB/m)	Cable Loss (dB)	Preamp Factor (dB)	Antenna Height (cm)	Table Angle (Degree)	Remark
2320.35	42.23	48.7	54	-11.77	26.72	4.28	37.47	216	347	Average
2365.71	52.92	59.28	74	-21.08	26.81	4.33	37.5	216	347	Peak
2437	90.68	96.68			27.06	4.4	37.46	216	347	Average
2437	99.57	105.57			27.06	4.4	37.46	216	347	Peak
2483.76	39.45	45.19	54	-14.55	27.15	4.43	37.32	216	347	Average
2494.36	49.81	55.42	74	-24.19	27.2	4.44	37.25	216	347	Peak
4874	34.96	50.09	54	-19.04	31.06	6.86	53.05	102	129	Average
4874	46.71	61.84	74	-27.29	31.06	6.86	53.05	102	129	Peak

Remarks:

- Emission Level = Read Level + Antenna Factor + Cable Loss - Preamp Factor
Margin value = Emission level – Limit value
- 2437 MHz: Fundamental frequency.

EUT Test Condition		Measurement Detail	
Channel	Channel 11	Frequency Range	1 GHz ~ 25 GHz
Input Power	120 Vac, 60 Hz	Detector Function	Peak (PK) Average (AV)
Environmental Conditions	25 deg. C, 65 % RH	Tested By	Gavin Wu

Antennal Polarity & Test Distance: Horizontal at 3 m										
Frequency (MHz)	Emission Level (dBuV/m)	Read Level (dBuV)	Limit (dBuV/m)	Margin (dB)	Antenna Factor (dB/m)	Cable Loss (dB)	Preamp Factor (dB)	Antenna Height (cm)	Table Angle (Degree)	Remark
2462	97.7	103.58			27.1	4.41	37.39	258	291	Average
2462	106.65	112.53			27.1	4.41	37.39	258	291	Peak
2483.56	70.17	75.91	74	-3.83	27.15	4.43	37.32	258	291	Peak
2483.68	49.23	54.97	54	-4.77	27.15	4.43	37.32	258	291	Average
4924	33.98	48.86	54	-20.02	31.12	6.89	52.89	155	162	Average
4924	45.38	60.26	74	-28.62	31.12	6.89	52.89	155	162	Peak
Antennal Polarity & Test Distance: Vertical at 3 m										
Frequency (MHz)	Emission Level (dBuV/m)	Read Level (dBuV)	Limit (dBuV/m)	Margin (dB)	Antenna Factor (dB/m)	Cable Loss (dB)	Preamp Factor (dB)	Antenna Height (cm)	Table Angle (Degree)	Remark
2462	90.72	96.6			27.1	4.41	37.39	211	351	Average
2462	99.25	105.13			27.1	4.41	37.39	211	351	Peak
2483.52	44.23	49.97	54	-9.77	27.15	4.43	37.32	211	351	Average
2483.52	64.51	70.25	74	-9.49	27.15	4.43	37.32	211	351	Peak
4924	34.85	49.87	54	-19.15	31.12	6.89	53.03	106	122	Average
4924	47.06	62.08	74	-26.94	31.12	6.89	53.03	106	122	Peak

Remarks:

- Emission Level = Read Level + Antenna Factor + Cable Loss - Preamp Factor
Margin value = Emission level – Limit value
- 2462 MHz: Fundamental frequency.

802.11n (HT20)

EUT Test Condition		Measurement Detail	
Channel	Channel 1	Frequency Range	1 GHz ~ 25 GHz
Input Power	120 Vac, 60 Hz	Detector Function	Peak (PK) Average (AV)
Environmental Conditions	25 deg. C, 65 % RH	Tested By	Gavin Wu

Antennal Polarity & Test Distance: Horizontal at 3 m

Frequency (MHz)	Emission Level (dBUV/m)	Read Level (dBUV)	Limit (dBUV/m)	Margin (dB)	Antenna Factor (dB/m)	Cable Loss (dB)	Preamp Factor (dB)	Antenna Height (cm)	Table Angle (Degree)	Remark
2389.65	52.35	58.58	54	-1.65	26.91	4.36	37.5	238	279	Average
2389.65	72.04	78.27	74	-1.96	26.91	4.36	37.5	238	279	Peak
2412	99.78	105.96			26.96	4.38	37.52	238	279	Average
2412	109.66	115.84			26.96	4.38	37.52	238	279	Peak
4824	33.85	48.94	54	-20.15	30.99	6.81	52.89	116	112	Average
4824	47.58	62.67	74	-26.42	30.99	6.81	52.89	116	112	Peak

Antennal Polarity & Test Distance: Vertical at 3 m

Frequency (MHz)	Emission Level (dBUV/m)	Read Level (dBUV)	Limit (dBUV/m)	Margin (dB)	Antenna Factor (dB/m)	Cable Loss (dB)	Preamp Factor (dB)	Antenna Height (cm)	Table Angle (Degree)	Remark
2388.93	60.85	67.08	74	-13.15	26.91	4.36	37.5	240	343	Peak
2389.38	43.97	50.2	54	-10.03	26.91	4.36	37.5	240	343	Average
2412	92.7	98.88			26.96	4.38	37.52	240	343	Average
2412	100.63	106.81			26.96	4.38	37.52	240	343	Peak
4824	34.56	49.84	54	-19.44	30.99	6.81	53.08	108	105	Average
4824	47.92	63.2	74	-26.08	30.99	6.81	53.08	108	105	Peak

Remarks:

- Emission Level = Read Level + Antenna Factor + Cable Loss - Preamp Factor
Margin value = Emission level – Limit value
- 2412 MHz: Fundamental frequency.

EUT Test Condition		Measurement Detail	
Channel	Channel 6	Frequency Range	1 GHz ~ 25 GHz
Input Power	120 Vac, 60 Hz	Detector Function	Peak (PK) Average (AV)
Environmental Conditions	25 deg. C, 65 % RH	Tested By	Gavin Wu

Antennal Polarity & Test Distance: Horizontal at 3 m										
Frequency (MHz)	Emission Level (dBuV/m)	Read Level (dBuV)	Limit (dBuV/m)	Margin (dB)	Antenna Factor (dB/m)	Cable Loss (dB)	Preamp Factor (dB)	Antenna Height (cm)	Table Angle (Degree)	Remark
2351.76	38.44	44.8	54	-15.56	26.81	4.32	37.49	154	287	Average
2389.56	52.17	58.4	74	-21.83	26.91	4.36	37.5	154	287	Peak
2437	100.1	106.1			27.06	4.4	37.46	154	287	Average
2437	109.16	115.16			27.06	4.4	37.46	154	287	Peak
2483.6	49.8	55.54	74	-24.2	27.15	4.43	37.32	154	287	Peak
2484.4	36.96	42.7	54	-17.04	27.15	4.43	37.32	154	287	Average
4874	33.72	48.66	54	-20.28	31.06	6.86	52.86	104	111	Average
4874	46.28	61.22	74	-27.72	31.06	6.86	52.86	104	111	Peak
Antennal Polarity & Test Distance: Vertical at 3 m										
Frequency (MHz)	Emission Level (dBuV/m)	Read Level (dBuV)	Limit (dBuV/m)	Margin (dB)	Antenna Factor (dB/m)	Cable Loss (dB)	Preamp Factor (dB)	Antenna Height (cm)	Table Angle (Degree)	Remark
2347.53	52.51	58.92	74	-21.49	26.77	4.31	37.49	245	344	Peak
2389.11	39.94	46.17	54	-14.06	26.91	4.36	37.5	245	344	Average
2437	90.97	97.03			27.01	4.39	37.46	245	344	Average
2437	100.28	106.34			27.01	4.39	37.46	245	344	Peak
2485.04	48.21	53.95	74	-25.79	27.15	4.43	37.32	245	344	Peak
2494.64	36.9	42.51	54	-17.1	27.2	4.44	37.25	245	344	Average
4874	34.01	49.14	54	-19.99	31.06	6.86	53.05	122	103	Average
4874	46.79	61.92	74	-27.21	31.06	6.86	53.05	122	103	Peak

Remarks:

- Emission Level = Read Level + Antenna Factor + Cable Loss - Preamp Factor
Margin value = Emission level – Limit value
- 2437 MHz: Fundamental frequency.

EUT Test Condition		Measurement Detail	
Channel	Channel 11	Frequency Range	1 GHz ~ 25 GHz
Input Power	120 Vac, 60 Hz	Detector Function	Peak (PK) Average (AV)
Environmental Conditions	25 deg. C, 65 % RH	Tested By	Gavin Wu

Antennal Polarity & Test Distance: Horizontal at 3 m										
Frequency (MHz)	Emission Level (dBuV/m)	Read Level (dBuV)	Limit (dBuV/m)	Margin (dB)	Antenna Factor (dB/m)	Cable Loss (dB)	Preamp Factor (dB)	Antenna Height (cm)	Table Angle (Degree)	Remark
2462	98.54	104.42			27.1	4.41	37.39	171	279	Average
2462	107.35	113.23			27.1	4.41	37.39	171	279	Peak
2483.52	50.86	56.6	54	-3.14	27.15	4.43	37.32	171	279	Average
2484.28	70.59	76.33	74	-3.41	27.15	4.43	37.32	171	279	Peak
4924	34.38	49.26	54	-19.62	31.12	6.89	52.89	107	144	Average
4924	46.92	61.8	74	-27.08	31.12	6.89	52.89	107	144	Peak
Antennal Polarity & Test Distance: Vertical at 3 m										
Frequency (MHz)	Emission Level (dBuV/m)	Read Level (dBuV)	Limit (dBuV/m)	Margin (dB)	Antenna Factor (dB/m)	Cable Loss (dB)	Preamp Factor (dB)	Antenna Height (cm)	Table Angle (Degree)	Remark
2462	89.4	95.28			27.1	4.41	37.39	260	344	Average
2462	98.34	104.22			27.1	4.41	37.39	260	344	Peak
2483.52	43.92	49.66	54	-10.08	27.15	4.43	37.32	260	344	Average
2484.16	62.95	68.69	74	-11.05	27.15	4.43	37.32	260	344	Peak
4924	34.98	50	54	-19.02	31.12	6.89	53.03	106	155	Average
4924	47.41	62.43	74	-26.59	31.12	6.89	53.03	106	155	Peak

Remarks:

- Emission Level = Read Level + Antenna Factor + Cable Loss - Preamp Factor
Margin value = Emission level – Limit value
- 2462 MHz: Fundamental frequency.

Mode B

802.11b

EUT Test Condition		Measurement Detail	
Channel	Channel 1	Frequency Range	1 GHz ~ 25 GHz
Input Power	120 Vac, 60 Hz	Detector Function	Peak (PK) Average (AV)
Environmental Conditions	25 deg. C, 65 % RH	Tested By	Gavin Wu

Antennal Polarity & Test Distance: Horizontal at 3 m										
Frequency (MHz)	Emission Level (dBuV/m)	Read Level (dBuV)	Limit (dBuV/m)	Margin (dB)	Antenna Factor (dB/m)	Cable Loss (dB)	Preamp Factor (dB)	Antenna Height (cm)	Table Angle (Degree)	Remark
2389.29	37.94	44.17	54	-16.06	26.91	4.36	37.5	197	205	Average
2389.29	50.7	56.93	74	-23.3	26.91	4.36	37.5	197	205	Peak
2412	98.01	104.19			26.96	4.38	37.52	197	205	Average
2412	104.1	110.28			26.96	4.38	37.52	197	205	Peak
4824	51.78	67.06	54	-2.22	30.99	6.81	53.08	131	256	Average
4824	53.58	68.86	74	-20.42	30.99	6.81	53.08	131	256	Peak

Antennal Polarity & Test Distance: Vertical at 3 m										
Frequency (MHz)	Emission Level (dBuV/m)	Read Level (dBuV)	Limit (dBuV/m)	Margin (dB)	Antenna Factor (dB/m)	Cable Loss (dB)	Preamp Factor (dB)	Antenna Height (cm)	Table Angle (Degree)	Remark
2386.14	46.91	53.15	74	-27.09	26.91	4.35	37.5	115	84	Peak
2389.74	33.79	40.02	54	-20.21	26.91	4.36	37.5	115	84	Average
2412	90.18	96.36			26.96	4.38	37.52	115	84	Average
2412	97.26	103.44			26.96	4.38	37.52	115	84	Peak
4824	52.84	68.12	54	-1.16	30.99	6.81	53.08	161	209	Average
4824	54.97	70.25	74	-19.03	30.99	6.81	53.08	161	209	Peak

Remarks:

- Emission Level = Read Level + Antenna Factor + Cable Loss - Preamp Factor
Margin value = Emission level – Limit value
- 2412 MHz: Fundamental frequency.

EUT Test Condition		Measurement Detail	
Channel	Channel 6	Frequency Range	1 GHz ~ 25 GHz
Input Power	120 Vac, 60 Hz	Detector Function	Peak (PK) Average (AV)
Environmental Conditions	25 deg. C, 65 % RH	Tested By	Gavin Wu

Antennal Polarity & Test Distance: Horizontal at 3 m										
Frequency (MHz)	Emission Level (dBuV/m)	Read Level (dBuV)	Limit (dBuV/m)	Margin (dB)	Antenna Factor (dB/m)	Cable Loss (dB)	Preamp Factor (dB)	Antenna Height (cm)	Table Angle (Degree)	Remark
2384.61	47.49	53.78	74	-26.51	26.86	4.35	37.5	216	200	Peak
2389.38	34.6	40.83	54	-19.4	26.91	4.36	37.5	216	200	Average
2437	98.84	104.84			27.06	4.4	37.46	216	200	Average
2437	104.39	110.39			27.06	4.4	37.46	216	200	Peak
2485.16	34.64	40.38	54	-19.36	27.15	4.43	37.32	216	200	Average
2492.8	48.26	53.88	74	-25.74	27.2	4.43	37.25	216	200	Peak
4874	50.87	66	54	-3.13	31.06	6.86	53.05	132	257	Average
4874	52.47	67.6	74	-21.53	31.06	6.86	53.05	132	257	Peak

Antennal Polarity & Test Distance: Vertical at 3 m										
Frequency (MHz)	Emission Level (dBuV/m)	Read Level (dBuV)	Limit (dBuV/m)	Margin (dB)	Antenna Factor (dB/m)	Cable Loss (dB)	Preamp Factor (dB)	Antenna Height (cm)	Table Angle (Degree)	Remark
2369.31	47.14	53.44	74	-26.86	26.86	4.34	37.5	114	88	Peak
2389.74	33.36	39.59	54	-20.64	26.91	4.36	37.5	114	88	Average
2437	92.25	98.25			27.06	4.4	37.46	114	88	Average
2437	97.63	103.63			27.06	4.4	37.46	114	88	Peak
2484.36	33.88	39.62	54	-20.12	27.15	4.43	37.32	114	88	Average
2493	47.7	53.31	74	-26.3	27.2	4.44	37.25	114	88	Peak
4874	52.69	67.82	54	-1.31	31.06	6.86	53.05	149	214	Average
4874	54.56	69.69	74	-19.44	31.06	6.86	53.05	149	214	Peak

Remarks:

- Emission Level = Read Level + Antenna Factor + Cable Loss - Preamp Factor
Margin value = Emission level – Limit value
- 2437 MHz: Fundamental frequency.

EUT Test Condition		Measurement Detail	
Channel	Channel 11	Frequency Range	1 GHz ~ 25 GHz
Input Power	120 Vac, 60 Hz	Detector Function	Peak (PK) Average (AV)
Environmental Conditions	25 deg. C, 65 % RH	Tested By	Gavin Wu

Antennal Polarity & Test Distance: Horizontal at 3 m										
Frequency (MHz)	Emission Level (dBuV/m)	Read Level (dBuV)	Limit (dBuV/m)	Margin (dB)	Antenna Factor (dB/m)	Cable Loss (dB)	Preamp Factor (dB)	Antenna Height (cm)	Table Angle (Degree)	Remark
2462	99.05	104.93			27.1	4.41	37.39	212	201	Average
2462	104.62	110.5			27.1	4.41	37.39	212	201	Peak
2483.52	36.39	42.13	54	-17.61	27.15	4.43	37.32	212	201	Average
2484.48	50.29	56.03	74	-23.71	27.15	4.43	37.32	212	201	Peak
4924	46.59	61.61	54	-7.41	31.12	6.89	53.03	147	257	Average
4924	48.84	63.86	74	-25.16	31.12	6.89	53.03	147	257	Peak

Antennal Polarity & Test Distance: Vertical at 3 m										
Frequency (MHz)	Emission Level (dBuV/m)	Read Level (dBuV)	Limit (dBuV/m)	Margin (dB)	Antenna Factor (dB/m)	Cable Loss (dB)	Preamp Factor (dB)	Antenna Height (cm)	Table Angle (Degree)	Remark
2462	92.31	98.19			27.1	4.41	37.39	114	93	Average
2462	97.31	103.19			27.1	4.41	37.39	114	93	Peak
2484.6	34.11	39.85	54	-19.89	27.15	4.43	37.32	114	93	Average
2485.72	47.61	53.35	74	-26.39	27.15	4.43	37.32	114	93	Peak
4924	52.66	67.68	54	-1.34	31.12	6.89	53.03	117	277	Average
4924	54.93	69.95	74	-19.07	31.12	6.89	53.03	117	277	Peak

Remarks:

- Emission Level = Read Level + Antenna Factor + Cable Loss - Preamp Factor
Margin value = Emission level – Limit value
- 2462 MHz: Fundamental frequency.

802.11g

EUT Test Condition		Measurement Detail	
Channel	Channel 1	Frequency Range	1 GHz ~ 25 GHz
Input Power	120 Vac, 60 Hz	Detector Function	Peak (PK) Average (AV)
Environmental Conditions	25 deg. C, 65 % RH	Tested By	Gavin Wu

Antennal Polarity & Test Distance: Horizontal at 3 m										
Frequency (MHz)	Emission Level (dBuV/m)	Read Level (dBuV)	Limit (dBuV/m)	Margin (dB)	Antenna Factor (dB/m)	Cable Loss (dB)	Preamp Factor (dB)	Antenna Height (cm)	Table Angle (Degree)	Remark
2389.92	51.89	58.14	54	-2.11	26.91	4.36	37.52	245	6	Average
2389.92	71.19	77.44	74	-2.81	26.91	4.36	37.52	245	6	Peak
2412	96.37	102.55			26.96	4.38	37.52	245	6	Average
2412	104.86	111.04			26.96	4.38	37.52	245	6	Peak
4824	45.54	60.63	54	-8.46	30.99	6.81	52.89	145	65	Average
4824	54.16	69.25	74	-19.84	30.99	6.81	52.89	145	65	Peak
Antennal Polarity & Test Distance: Vertical at 3 m										
Frequency (MHz)	Emission Level (dBuV/m)	Read Level (dBuV)	Limit (dBuV/m)	Margin (dB)	Antenna Factor (dB/m)	Cable Loss (dB)	Preamp Factor (dB)	Antenna Height (cm)	Table Angle (Degree)	Remark
2389.92	47.88	54.13	54	-6.12	26.91	4.36	37.52	244	270	Average
2389.92	65.41	71.66	74	-8.59	26.91	4.36	37.52	244	270	Peak
2412	92.43	98.61			26.96	4.38	37.52	244	270	Average
2412	101.03	107.21			26.96	4.38	37.52	244	270	Peak
4824	48.03	63.31	54	-5.97	30.99	6.81	53.08	149	216	Average
4824	57.91	73.19	74	-16.09	30.99	6.81	53.08	149	216	Peak

Remarks:

- Emission Level = Read Level + Antenna Factor + Cable Loss - Preamp Factor
Margin value = Emission level – Limit value
- 2412 MHz: Fundamental frequency.

EUT Test Condition		Measurement Detail	
Channel	Channel 6	Frequency Range	1 GHz ~ 25 GHz
Input Power	120 Vac, 60 Hz	Detector Function	Peak (PK) Average (AV)
Environmental Conditions	25 deg. C, 65 % RH	Tested By	Gavin Wu

Antennal Polarity & Test Distance: Horizontal at 3 m										
Frequency (MHz)	Emission Level (dBuV/m)	Read Level (dBuV)	Limit (dBuV/m)	Margin (dB)	Antenna Factor (dB/m)	Cable Loss (dB)	Preamp Factor (dB)	Antenna Height (cm)	Table Angle (Degree)	Remark
2388.21	50.72	56.95	74	-23.28	26.91	4.36	37.5	239	12	Peak
2389.92	37.2	43.45	54	-16.8	26.91	4.36	37.52	239	12	Average
2437	98.63	104.63			27.06	4.4	37.46	239	12	Average
2437	107.39	113.39			27.06	4.4	37.46	239	12	Peak
2483.52	37.28	43.02	54	-16.72	27.15	4.43	37.32	239	12	Average
2489.6	50.42	56.11	74	-23.58	27.2	4.43	37.32	239	12	Peak
4874	43.91	58.85	54	-10.09	31.06	6.86	52.86	148	179	Average
4874	51.98	66.92	74	-22.02	31.06	6.86	52.86	148	179	Peak
Antennal Polarity & Test Distance: Vertical at 3 m										
Frequency (MHz)	Emission Level (dBuV/m)	Read Level (dBuV)	Limit (dBuV/m)	Margin (dB)	Antenna Factor (dB/m)	Cable Loss (dB)	Preamp Factor (dB)	Antenna Height (cm)	Table Angle (Degree)	Remark
2388.39	48.94	55.17	74	-25.06	26.91	4.36	37.5	243	270	Peak
2389.74	36.74	42.97	54	-17.26	26.91	4.36	37.5	243	270	Average
2437	94.54	100.54			27.06	4.4	37.46	243	270	Average
2437	103.15	109.15			27.06	4.4	37.46	243	270	Peak
2484.04	49.5	55.24	74	-24.5	27.15	4.43	37.32	243	270	Peak
2486.72	36.95	42.69	54	-17.05	27.15	4.43	37.32	243	270	Average
4874	46.93	62.06	54	-7.07	31.06	6.86	53.05	168	72	Average
4874	58.19	73.32	74	-15.81	31.06	6.86	53.05	168	72	Peak

Remarks:

- Emission Level = Read Level + Antenna Factor + Cable Loss - Preamp Factor
Margin value = Emission level – Limit value
- 2437 MHz: Fundamental frequency.

EUT Test Condition		Measurement Detail	
Channel	Channel 11	Frequency Range	1 GHz ~ 25 GHz
Input Power	120 Vac, 60 Hz	Detector Function	Peak (PK) Average (AV)
Environmental Conditions	25 deg. C, 65 % RH	Tested By	Gavin Wu

Antennal Polarity & Test Distance: Horizontal at 3 m										
Frequency (MHz)	Emission Level (dBuV/m)	Read Level (dBuV)	Limit (dBuV/m)	Margin (dB)	Antenna Factor (dB/m)	Cable Loss (dB)	Preamp Factor (dB)	Antenna Height (cm)	Table Angle (Degree)	Remark
2462	98.32	104.2			27.1	4.41	37.39	216	6	Average
2462	107.1	112.98			27.1	4.41	37.39	216	6	Peak
2483.56	52.41	58.15	54	-1.59	27.15	4.43	37.32	216	6	Average
2483.64	72.61	78.35	74	-1.39	27.15	4.43	37.32	216	6	Peak
4924	39.57	54.45	54	-14.43	31.12	6.89	52.89	100	181	Average
4924	49.06	63.94	74	-24.94	31.12	6.89	52.89	100	181	Peak
Antennal Polarity & Test Distance: Vertical at 3 m										
Frequency (MHz)	Emission Level (dBuV/m)	Read Level (dBuV)	Limit (dBuV/m)	Margin (dB)	Antenna Factor (dB/m)	Cable Loss (dB)	Preamp Factor (dB)	Antenna Height (cm)	Table Angle (Degree)	Remark
2462	94.34	100.22			27.1	4.41	37.39	234	269	Average
2462	102.91	108.79			27.1	4.41	37.39	234	269	Peak
2483.52	70.47	76.21	74	-3.53	27.15	4.43	37.32	234	269	Peak
2483.56	50.44	56.18	54	-3.56	27.15	4.43	37.32	234	269	Average
4924	41.32	56.34	54	-12.68	31.12	6.89	53.03	132	238	Average
4924	52.42	67.44	74	-21.58	31.12	6.89	53.03	132	238	Peak

Remarks:

- Emission Level = Read Level + Antenna Factor + Cable Loss - Preamp Factor
Margin value = Emission level – Limit value
- 2462 MHz: Fundamental frequency.

802.11n (HT20)

EUT Test Condition		Measurement Detail	
Channel	Channel 1	Frequency Range	1 GHz ~ 25 GHz
Input Power	120 Vac, 60 Hz	Detector Function	Peak (PK) Average (AV)
Environmental Conditions	25 deg. C, 65 % RH	Tested By	Gavin Wu

Antennal Polarity & Test Distance: Horizontal at 3 m

Frequency (MHz)	Emission Level (dBuV/m)	Read Level (dBuV)	Limit (dBuV/m)	Margin (dB)	Antenna Factor (dB/m)	Cable Loss (dB)	Preamp Factor (dB)	Antenna Height (cm)	Table Angle (Degree)	Remark
2389.83	72.14	78.39	74	-1.86	26.91	4.36	37.52	221	16	Peak
2389.92	51.2	57.45	54	-2.8	26.91	4.36	37.52	221	16	Average
2412	95.6	101.78			26.96	4.38	37.52	221	16	Average
2412	104.26	110.44			26.96	4.38	37.52	221	16	Peak
4824	38.28	53.37	54	-15.72	30.99	6.81	52.89	152	137	Average
4824	47.98	63.07	74	-26.02	30.99	6.81	52.89	152	137	Peak

Antennal Polarity & Test Distance: Vertical at 3 m

Frequency (MHz)	Emission Level (dBuV/m)	Read Level (dBuV)	Limit (dBuV/m)	Margin (dB)	Antenna Factor (dB/m)	Cable Loss (dB)	Preamp Factor (dB)	Antenna Height (cm)	Table Angle (Degree)	Remark
2389.83	67.35	73.6	74	-6.65	26.91	4.36	37.52	245	271	Peak
2389.92	47.28	53.53	54	-6.72	26.91	4.36	37.52	245	271	Average
2412	90.55	96.73			26.96	4.38	37.52	245	271	Average
2412	99.46	105.64			26.96	4.38	37.52	245	271	Peak
4824	41.03	56.31	54	-12.97	30.99	6.81	53.08	148	214	Average
4824	52.64	67.92	74	-21.36	30.99	6.81	53.08	148	214	Peak

Remarks:

- Emission Level = Read Level + Antenna Factor + Cable Loss - Preamp Factor
Margin value = Emission level – Limit value
- 2412 MHz: Fundamental frequency.

EUT Test Condition		Measurement Detail	
Channel	Channel 6	Frequency Range	1 GHz ~ 25 GHz
Input Power	120 Vac, 60 Hz	Detector Function	Peak (PK) Average (AV)
Environmental Conditions	25 deg. C, 65 % RH	Tested By	Gavin Wu

Antennal Polarity & Test Distance: Horizontal at 3 m										
Frequency (MHz)	Emission Level (dBuV/m)	Read Level (dBuV)	Limit (dBuV/m)	Margin (dB)	Antenna Factor (dB/m)	Cable Loss (dB)	Preamp Factor (dB)	Antenna Height (cm)	Table Angle (Degree)	Remark
2389.74	54.54	60.77	74	-19.46	26.91	4.36	37.5	241	13	Peak
2389.83	38.4	44.65	54	-15.6	26.91	4.36	37.52	241	13	Average
2437	99.09	105.09			27.06	4.4	37.46	241	13	Average
2437	108.15	114.15			27.06	4.4	37.46	241	13	Peak
2483.92	37.72	43.46	54	-16.28	27.15	4.43	37.32	241	13	Average
2484.08	52.56	58.3	74	-21.44	27.15	4.43	37.32	241	13	Peak
4874	44.29	59.23	54	-9.71	31.06	6.86	52.86	131	254	Average
4874	51.72	66.66	74	-22.28	31.06	6.86	52.86	131	254	Peak

Antennal Polarity & Test Distance: Vertical at 3 m										
Frequency (MHz)	Emission Level (dBuV/m)	Read Level (dBuV)	Limit (dBuV/m)	Margin (dB)	Antenna Factor (dB/m)	Cable Loss (dB)	Preamp Factor (dB)	Antenna Height (cm)	Table Angle (Degree)	Remark
2382.54	48.92	55.21	74	-25.08	26.86	4.35	37.5	269	273	Peak
2389.92	36.24	42.49	54	-17.76	26.91	4.36	37.52	269	273	Average
2437	94.2	100.2			27.06	4.4	37.46	269	273	Average
2437	103.17	109.17			27.06	4.4	37.46	269	273	Peak
2483.76	37.4	43.14	54	-16.6	27.15	4.43	37.32	269	273	Average
2483.96	51.37	57.11	74	-22.63	27.15	4.43	37.32	269	273	Peak
4874	44.34	59.47	54	-9.66	31.06	6.86	53.05	157	235	Average
4874	55.08	70.21	74	-18.92	31.06	6.86	53.05	157	235	Peak

Remarks:

- Emission Level = Read Level + Antenna Factor + Cable Loss - Preamp Factor
Margin value = Emission level – Limit value
- 2437 MHz: Fundamental frequency.

EUT Test Condition		Measurement Detail	
Channel	Channel 11	Frequency Range	1 GHz ~ 25 GHz
Input Power	120 Vac, 60 Hz	Detector Function	Peak (PK) Average (AV)
Environmental Conditions	25 deg. C, 65 % RH	Tested By	Gavin Wu

Antennal Polarity & Test Distance: Horizontal at 3 m										
Frequency (MHz)	Emission Level (dBuV/m)	Read Level (dBuV)	Limit (dBuV/m)	Margin (dB)	Antenna Factor (dB/m)	Cable Loss (dB)	Preamp Factor (dB)	Antenna Height (cm)	Table Angle (Degree)	Remark
2462	96.65	102.53			27.1	4.41	37.39	236	14	Average
2462	105.77	111.65			27.1	4.41	37.39	236	14	Peak
2483.64	51.96	57.7	54	-2.04	27.15	4.43	37.32	236	14	Average
2483.96	72.25	77.99	74	-1.75	27.15	4.43	37.32	236	14	Peak
4924	37.26	52.14	54	-16.74	31.12	6.89	52.89	139	61	Average
4924	46.79	61.67	74	-27.21	31.12	6.89	52.89	139	61	Peak
Antennal Polarity & Test Distance: Vertical at 3 m										
Frequency (MHz)	Emission Level (dBuV/m)	Read Level (dBuV)	Limit (dBuV/m)	Margin (dB)	Antenna Factor (dB/m)	Cable Loss (dB)	Preamp Factor (dB)	Antenna Height (cm)	Table Angle (Degree)	Remark
2462	92.14	98.02			27.1	4.41	37.39	268	274	Average
2462	101.19	107.07			27.1	4.41	37.39	268	274	Peak
2483.68	49.18	54.92	54	-4.82	27.15	4.43	37.32	268	274	Average
2484.12	69.37	75.11	74	-4.63	27.15	4.43	37.32	268	274	Peak
4924	39.11	54.13	54	-14.89	31.12	6.89	53.03	131	241	Average
4924	49.69	64.71	74	-24.31	31.12	6.89	53.03	131	241	Peak

Remarks:

- Emission Level = Read Level + Antenna Factor + Cable Loss - Preamp Factor
Margin value = Emission level – Limit value
- 2462 MHz: Fundamental frequency.

9 kHz ~ 30 MHz DATA:

The amplitude of spurious emissions attenuated more than 20 dB below the permissible value is not required to be report.

30 MHz ~ 1 GHz WORST-CASE DATA:

Mode A

802.11g

EUT Test Condition		Measurement Detail	
Channel	Channel 1	Frequency Range	30 MHz ~ 1 GHz
Input Power	120 Vac, 60 Hz	Detector Function	Peak (PK) Quasi-peak (QP)
Environmental Conditions	25 deg. C, 65 % RH	Tested By	Gavin Wu

Antennal Polarity & Test Distance: Horizontal at 3 m										
Frequency (MHz)	Emission Level (dBuV/m)	Read Level (dBuV)	Limit (dBuV/m)	Margin (dB)	Antenna Factor (dB/m)	Cable Loss (dB)	Preamp Factor (dB)	Antenna Height (cm)	Table Angle (Degree)	Remark
62.01	34.29	53.44	40	-5.71	11.71	0.59	31.45	133	243	Peak
73.65	34.01	55.26	40	-5.99	9.81	0.65	31.71	123	135	Peak
170.65	37.71	56.71	43.5	-5.79	11.67	1.07	31.74	117	150	Peak
305.48	35.07	52.21	46	-10.93	13.08	1.68	31.9	108	224	Peak
384.05	39.69	54.7	46	-6.31	14.96	2.02	31.99	138	314	Peak
647.89	25.54	34.28	46	-20.46	20.19	3.1	32.03	131	167	Peak
Antennal Polarity & Test Distance: Vertical at 3 m										
Frequency (MHz)	Emission Level (dBuV/m)	Read Level (dBuV)	Limit (dBuV/m)	Margin (dB)	Antenna Factor (dB/m)	Cable Loss (dB)	Preamp Factor (dB)	Antenna Height (cm)	Table Angle (Degree)	Remark
31.94	32.48	50.84	40	-7.52	12.3	0.45	31.11	107	332	Peak
81.41	32.87	55.6	40	-7.13	8.15	0.68	31.56	114	205	Peak
167.74	30.36	49.1	43.5	-13.14	11.96	1.06	31.76	119	182	Peak
304.51	31.59	48.75	46	-14.41	13.06	1.67	31.89	127	66	Peak
399.57	28.09	42.8	46	-17.91	15.33	2.09	32.13	138	162	Peak
628.49	33.74	42.92	46	-12.26	19.95	3.02	32.15	105	303	Peak

Remarks:

- Emission Level = Read Level + Antenna Factor + Cable Loss - Preamp Factor
Margin value = Emission level – Limit value

Mode B
802.11g

EUT Test Condition		Measurement Detail	
Channel	Channel 1	Frequency Range	30 MHz ~ 1 GHz
Input Power	120 Vac, 60 Hz	Detector Function	Peak (PK) Quasi-peak (QP)
Environmental Conditions	25 deg. C, 65 % RH	Tested By	Gavin Wu

Antennal Polarity & Test Distance: Horizontal at 3 m										
Frequency (MHz)	Emission Level (dBuV/m)	Read Level (dBuV)	Limit (dBuV/m)	Margin (dB)	Antenna Factor (dB/m)	Cable Loss (dB)	Preamp Factor (dB)	Antenna Height (cm)	Table Angle (Degree)	Remark
152.22	39.06	57.02	43.5	-4.44	12.71	0.99	31.66	117	253	Peak
240.49	37.26	56.54	46	-8.74	11.07	1.44	31.79	112	201	Peak
305.48	37.39	54.53	46	-8.61	13.08	1.68	31.9	100	290	Peak
395.69	32.87	47.65	46	-13.13	15.24	2.07	32.09	138	219	Peak
426.73	32.56	46.53	46	-13.44	15.87	2.18	32.02	123	318	Peak
531.49	26.31	37.33	46	-19.69	18.04	2.64	31.7	127	121	Peak
Antennal Polarity & Test Distance: Vertical at 3 m										
Frequency (MHz)	Emission Level (dBuV/m)	Read Level (dBuV)	Limit (dBuV/m)	Margin (dB)	Antenna Factor (dB/m)	Cable Loss (dB)	Preamp Factor (dB)	Antenna Height (cm)	Table Angle (Degree)	Remark
31.94	33.79	52.15	40	-6.21	12.3	0.45	31.11	122	182	Peak
69.77	35.98	56.39	40	-4.02	10.77	0.64	31.82	107	244	Peak
153.19	34.77	52.75	43.5	-8.73	12.72	0.99	31.69	134	1	Peak
330.7	20.43	36.77	46	-25.57	13.68	1.79	31.81	109	79	Peak
426.73	25.86	39.83	46	-20.14	15.87	2.18	32.02	134	183	Peak
520.82	27.59	38.79	46	-18.41	17.79	2.59	31.58	135	35	Peak

Remarks:

2. Emission Level = Read Level + Antenna Factor + Cable Loss - Preamp Factor

Margin value = Emission level – Limit value

4.2 Conducted Emission Measurement

4.2.1 Limits of Conducted Emission Measurement

Frequency (MHz)	Conducted Limit (dBuV)	
	Quasi-peak	Average
0.15 - 0.5	66 - 56	56 - 46
0.50 - 5.0	56	46
5.0 - 30.0	60	50

Note: 1. The lower limit shall apply at the transition frequencies.

2. The limit decreases in line with the logarithm of the frequency in the range of 0.15 to 0.50 MHz.

4.2.2 Test Instruments

Description & Manufacturer	Model No.	Serial No.	Date of Calibration	Due Date of Calibration
Test Receiver ROHDE & SCHWARZ	ESCI	100613	Nov. 21, 2016	Nov. 20, 2017
RF signal cable Woken	5D-FB	Cable-cond1-01	Dec. 22, 2016	Dec. 21, 2017
LISN ROHDE & SCHWARZ (EUT)	ESH3-Z5	835239/001	Mar. 10, 2017	Mar. 09, 2018
LISN ROHDE & SCHWARZ (Peripheral)	ESH3-Z5	100311	Aug. 15, 2017	Aug. 14, 2018
Software ADT	BV ADT_Cond_ V7.3.7.3	NA	NA	NA

Note: 1. The calibration interval of the above test instruments is 12 months and the calibrations are traceable to NML/ROC and NIST/USA.

2. The test was performed in HwaYa Shielded Room 1.

3. The VCCI Site Registration No. is C-2040.

4.2.3 Test Procedures

- a. The EUT was placed 0.4 meters from the conducting wall of the shielded room with EUT being connected to the power mains through a line impedance stabilization network (LISN). Other support units were connected to the power mains through another LISN. The two LISNs provide 50 ohm/50 uH of coupling impedance for the measuring instrument.
- b. Both lines of the power mains connected to the EUT were checked for maximum conducted interference.
- c. The frequency range from 150 kHz to 30 MHz was searched. Emission levels under (Limit – 20 dB) was not recorded.

NOTE: All modes of operation were investigated and the worst-case emissions are reported.

4.2.4 Deviation from Test Standard

No deviation.

4.2.5 Test Setup

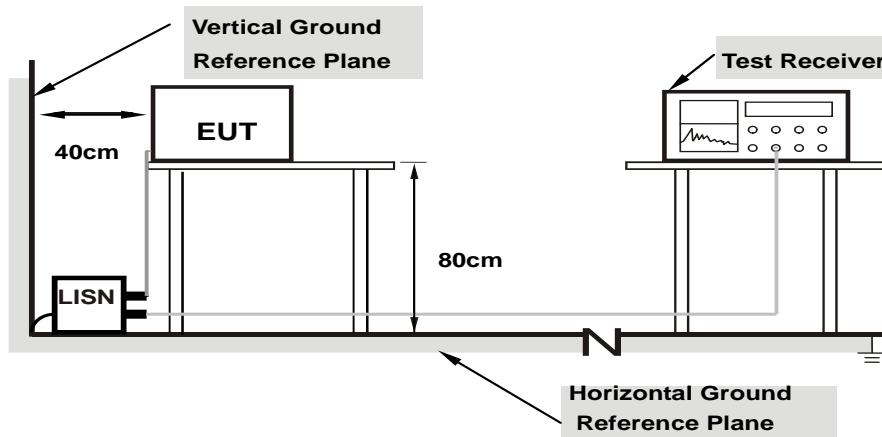

Note: 1. Support units were connected to second LISN.

For the actual test configuration, please refer to the attached file (Test Setup Photo).

4.2.6 EUT Operating Conditions

- a. Placed the EUT on a testing table.
- b. Use the software to control the EUT under transmission condition continuously at specific channel frequency.

4.2.7 Test Results

Mode A

Frequency Range	150kHz ~ 30MHz	Detector Function & Resolution Bandwidth	Quasi-Peak (QP) / Average (AV), 9kHz
Input Power	120Vac, 60Hz	Environmental Conditions	26°C, 72%RH
Tested by	Han Wu	Test Date	2017/8/23

Phase Of Power : Line (L)										
No	Frequency (MHz)	Correction Factor (dB)	Reading Value (dBuV)		Emission Level (dBuV)		Limit (dBuV)		Margin (dB)	
			Q.P.	AV.	Q.P.	AV.	Q.P.	AV.	Q.P.	AV.
1	0.17338	10.36	44.06	25.53	54.42	35.89	64.80	54.80	-10.38	-18.91
2	0.18617	10.36	43.16	28.17	53.52	38.53	64.21	54.21	-10.69	-15.68
3	0.23800	10.38	36.86	24.83	47.24	35.21	62.17	52.17	-14.93	-16.96
4	1.68600	10.44	21.22	11.41	31.66	21.85	56.00	46.00	-24.34	-24.15
5	13.69800	11.02	14.83	9.25	25.85	20.27	60.00	50.00	-34.15	-29.73
6	26.95000	11.57	15.49	10.59	27.06	22.16	60.00	50.00	-32.94	-27.84

Remarks:

1. Q.P. and AV. are abbreviations of quasi-peak and average individually.
2. The emission levels of other frequencies were very low against the limit.
3. Margin value = Emission level – Limit value
4. Correction factor = Insertion loss + Cable loss
5. Emission Level = Correction Factor + Reading Value

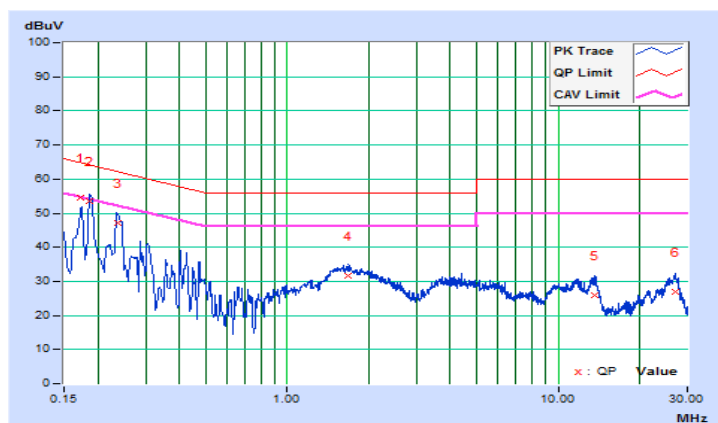

Frequency Range	150kHz ~ 30MHz	Detector Function & Resolution Bandwidth	Quasi-Peak (QP) / Average (AV), 9kHz
Input Power	120Vac, 60Hz	Environmental Conditions	26°C, 72%RH
Tested by	Han Wu	Test Date	2017/8/23

Phase Of Power : Neutral (N)										
No	Frequency (MHz)	Correction Factor (dB)	Reading Value (dBuV)		Emission Level (dBuV)		Limit (dBuV)		Margin (dB)	
			Q.P.	AV.	Q.P.	AV.	Q.P.	AV.	Q.P.	AV.
1	0.18180	10.13	42.91	30.65	53.04	40.78	64.40	54.40	-11.36	-13.62
2	0.24600	10.14	33.81	22.03	43.95	32.17	61.89	51.89	-17.94	-19.72
3	0.30600	10.15	25.40	15.56	35.55	25.71	60.08	50.08	-24.53	-24.37
4	0.37800	10.16	16.58	3.98	26.74	14.14	58.32	48.32	-31.58	-34.18
5	0.40179	10.16	19.25	3.84	29.41	14.00	57.82	47.82	-28.41	-33.82
6	13.42600	10.69	17.60	10.52	28.29	21.21	60.00	50.00	-31.71	-28.79

Remarks:

1. Q.P. and AV. are abbreviations of quasi-peak and average individually.
2. The emission levels of other frequencies were very low against the limit.
3. Margin value = Emission level – Limit value
4. Correction factor = Insertion loss + Cable loss
5. Emission Level = Correction Factor + Reading Value

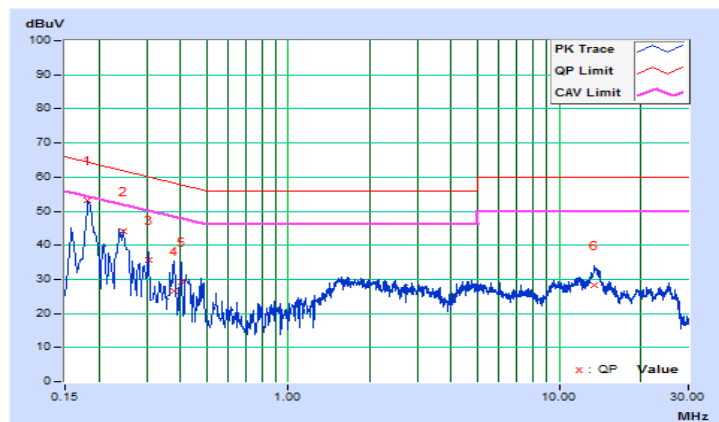

Mode B

Frequency Range	150kHz ~ 30MHz	Detector Function & Resolution Bandwidth	Quasi-Peak (QP) / Average (AV), 9kHz
Input Power	120Vac, 60Hz	Environmental Conditions	26°C, 72%RH
Tested by	Han Wu	Test Date	2017/8/23

Phase Of Power : Line (L)										
No	Frequency (MHz)	Correction Factor (dB)	Reading Value (dBuV)		Emission Level (dBuV)		Limit (dBuV)		Margin (dB)	
			Q.P.	AV.	Q.P.	AV.	Q.P.	AV.	Q.P.	AV.
1	0.16623	10.35	44.24	31.48	54.59	41.83	65.15	55.15	-10.56	-13.32
2	0.22211	10.37	36.67	25.40	47.04	35.77	62.74	52.74	-15.70	-16.97
3	0.27859	10.38	28.79	18.77	39.17	29.15	60.86	50.86	-21.69	-21.71
4	0.39000	10.40	23.63	16.18	34.03	26.58	58.06	48.06	-24.03	-21.48
5	1.73800	10.44	20.52	11.97	30.96	22.41	56.00	46.00	-25.04	-23.59
6	13.58200	11.01	14.86	9.57	25.87	20.58	60.00	50.00	-34.13	-29.42

Remarks:

1. Q.P. and AV. are abbreviations of quasi-peak and average individually.
2. The emission levels of other frequencies were very low against the limit.
3. Margin value = Emission level – Limit value
4. Correction factor = Insertion loss + Cable loss
5. Emission Level = Correction Factor + Reading Value

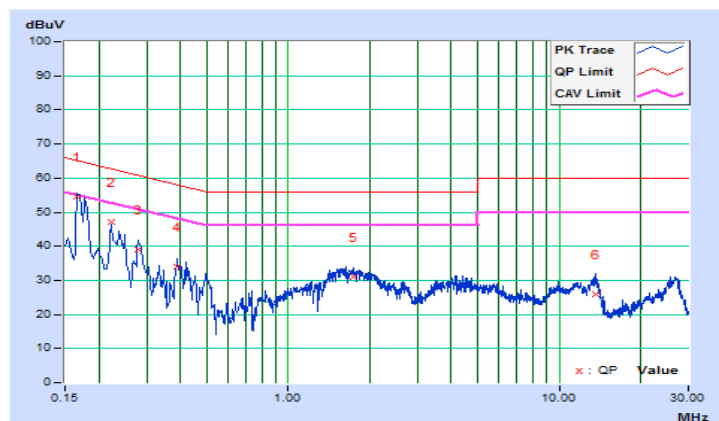

Frequency Range	150kHz ~ 30MHz	Detector Function & Resolution Bandwidth	Quasi-Peak (QP) / Average (AV), 9kHz
Input Power	120Vac, 60Hz	Environmental Conditions	26°C, 72%RH
Tested by	Han Wu	Test Date	2017/8/23

Phase Of Power : Neutral (N)										
No	Frequency (MHz)	Correction Factor (dB)	Reading Value (dBuV)		Emission Level (dBuV)		Limit (dBuV)		Margin (dB)	
			Q.P.	AV.	Q.P.	AV.	Q.P.	AV.	Q.P.	AV.
1	0.16579	10.12	43.91	27.63	54.03	37.75	65.17	55.17	-11.14	-17.42
2	0.18180	10.13	41.56	25.21	51.69	35.34	64.40	54.40	-12.71	-19.06
3	0.24200	10.14	34.08	20.71	44.22	30.85	62.03	52.03	-17.81	-21.18
4	0.31000	10.15	20.37	7.82	30.52	17.97	59.97	49.97	-29.45	-32.00
5	0.41799	10.16	20.71	8.74	30.87	18.90	57.49	47.49	-26.62	-28.59
6	13.59800	10.69	17.68	10.44	28.37	21.13	60.00	50.00	-31.63	-28.87

Remarks:

1. Q.P. and AV. are abbreviations of quasi-peak and average individually.
2. The emission levels of other frequencies were very low against the limit.
3. Margin value = Emission level – Limit value
4. Correction factor = Insertion loss + Cable loss
5. Emission Level = Correction Factor + Reading Value

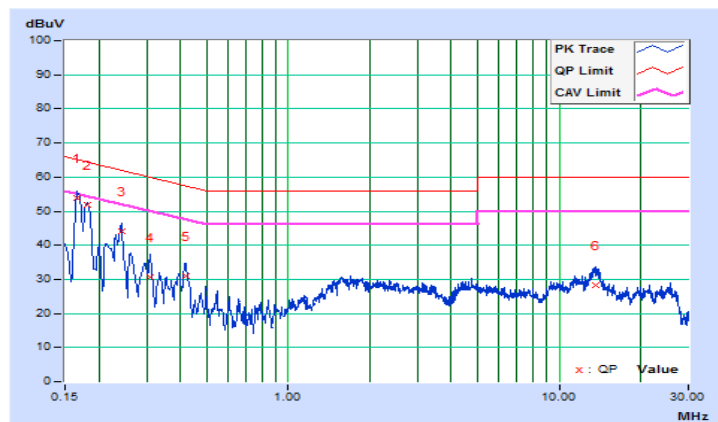

4.3 6 dB Bandwidth Measurement

4.3.1 Limits of 6 dB Bandwidth Measurement

The minimum of 6 dB Bandwidth Measurement is 0.5 MHz.

4.3.2 Test Setup

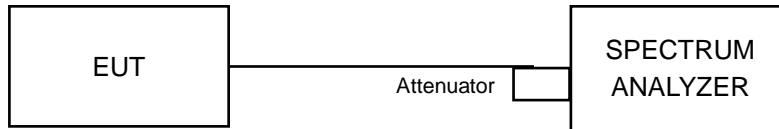

4.3.3 Test Instruments

Refer to section 4.1.2 to get information of above instrument.

4.3.4 Test Procedure

- Set resolution bandwidth (RBW) = 100 kHz
- Set the video bandwidth (VBW) $\geq 3 \times$ RBW, Detector = Peak.
- Trace mode = max hold.
- Sweep = auto couple.
- Measure the maximum width of the emission that is constrained by the frequencies associated with the two amplitude points (upper and lower) that are attenuated by 6 dB relative to the maximum level measured in the fundamental emission

4.3.5 Deviation from Test Standard

No deviation.

4.3.6 EUT Operating Conditions

The software provided by client to enable the EUT under transmission condition continuously at lowest, middle and highest channel frequencies individually.

4.3.7 Test Result

Mode A

802.11b

Channel	Frequency (MHz)	6 dB Bandwidth (MHz)	Minimum Limit (MHz)	Pass / Fail
1	2412	9.57	0.5	Pass
6	2437	9.56	0.5	Pass
11	2462	9.06	0.5	Pass

802.11g

Channel	Frequency (MHz)	6 dB Bandwidth (MHz)	Minimum Limit (MHz)	Pass / Fail
1	2412	15.18	0.5	Pass
6	2437	15.31	0.5	Pass
11	2462	15.19	0.5	Pass

802.11n (HT20)

Channel	Frequency (MHz)	6 dB Bandwidth (MHz)	Minimum Limit (MHz)	Pass / Fail
1	2412	15.18	0.5	Pass
6	2437	15.19	0.5	Pass
11	2462	15.20	0.5	Pass

Spectrum Plot of Worst Value

802.11b

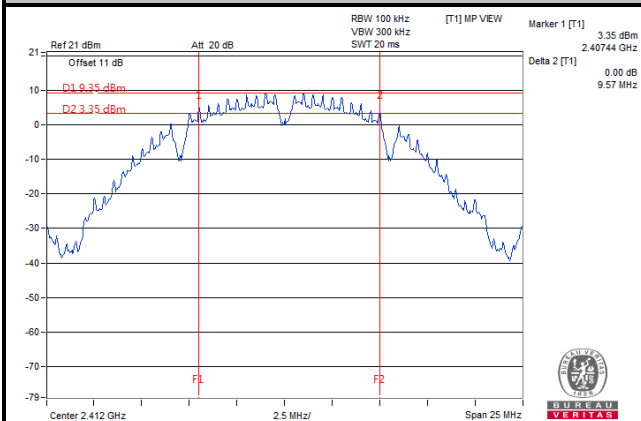

802.11g

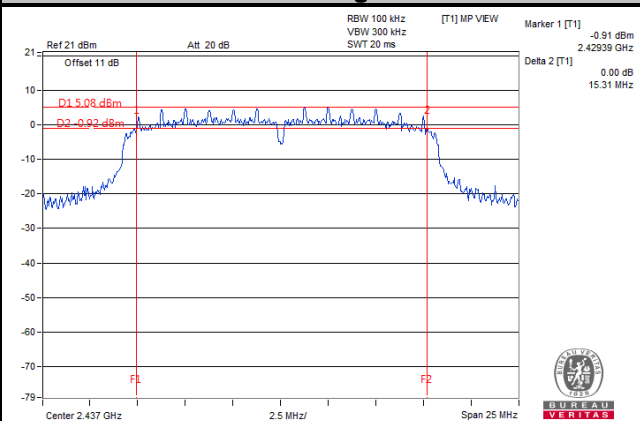

802.11n (HT20)

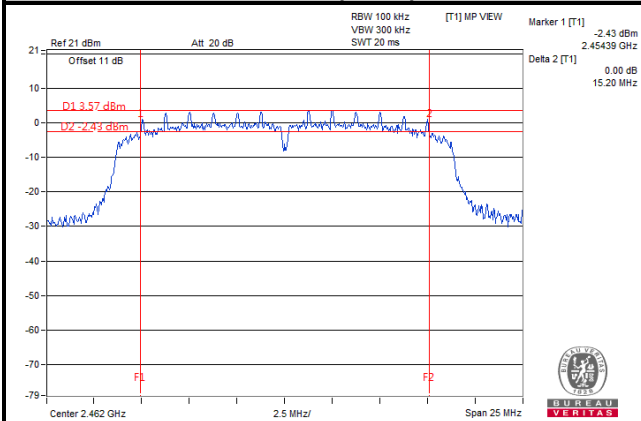

Mode B
802.11b

Channel	Frequency (MHz)	6 dB Bandwidth (MHz)	Minimum Limit (MHz)	Pass / Fail
1	2412	9.57	0.5	Pass
6	2437	9.56	0.5	Pass
11	2462	9.06	0.5	Pass

802.11g

Channel	Frequency (MHz)	6 dB Bandwidth (MHz)	Minimum Limit (MHz)	Pass / Fail
1	2412	15.18	0.5	Pass
6	2437	15.31	0.5	Pass
11	2462	15.19	0.5	Pass

802.11n (HT20)

Channel	Frequency (MHz)	6 dB Bandwidth (MHz)	Minimum Limit (MHz)	Pass / Fail
1	2412	15.18	0.5	Pass
6	2437	15.19	0.5	Pass
11	2462	15.20	0.5	Pass

Spectrum Plot of Worst Value

802.11b

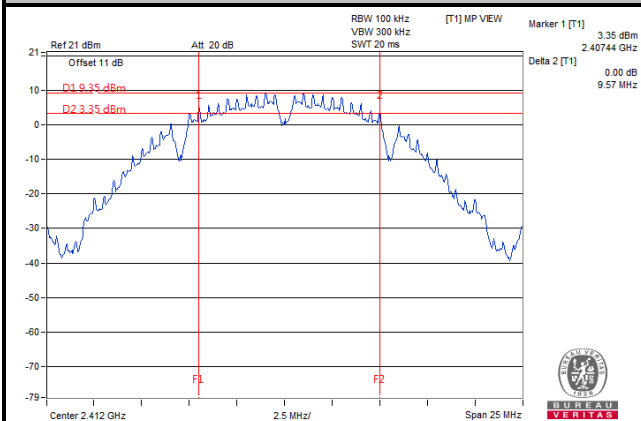

802.11g

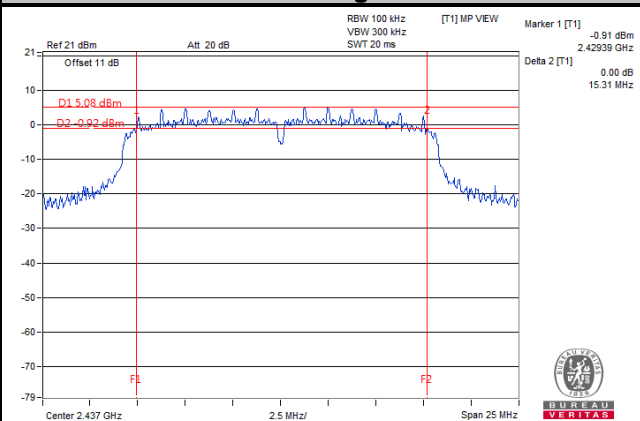

802.11n (HT20)

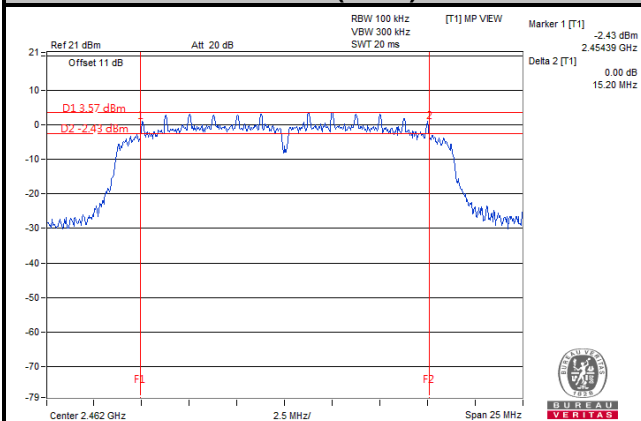

4.4 Conducted Output Power Measurement

4.4.1 Limits of Conducted Output Power Measurement

For systems using digital modulation in the 2400–2483.5 MHz bands: 1 Watt (30 dBm)

4.4.2 Test Setup

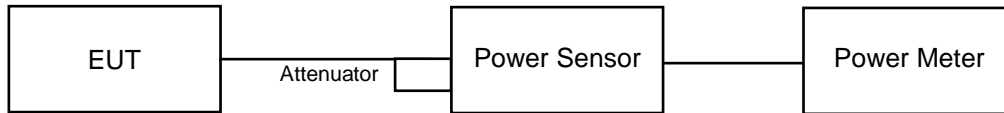

4.4.3 Test Instruments

Refer to section 4.1.2 to get information of above instrument.

4.4.4 Test Procedures

A peak power sensor was used on the output port of the EUT. A power meter was used to read the response of the peak power sensor. Record the power level.

4.4.5 Deviation from Test Standard

No deviation.

4.4.6 EUT Operating Conditions

The software provided by client to enable the EUT under transmission condition continuously at lowest, middle and highest channel frequencies individually.

4.4.7 Test Results

Mode A

802.11b

Channel	Frequency (MHz)	Peak Power (mW)	Peak Power (dBm)	Limit (dBm)	Pass / Fail
1	2412	111.429	20.47	30	Pass
6	2437	103.753	20.16	30	Pass
11	2462	95.94	19.82	30	Pass

802.11g

Channel	Frequency (MHz)	Peak Power (mW)	Peak Power (dBm)	Limit (dBm)	Pass / Fail
1	2412	182.81	22.62	30	Pass
6	2437	166.341	22.21	30	Pass
11	2462	153.462	21.86	30	Pass

802.11n (HT20)

Channel	Frequency (MHz)	Peak Power (mW)	Peak Power (dBm)	Limit (dBm)	Pass / Fail
1	2412	184.502	22.66	30	Pass
6	2437	178.238	22.51	30	Pass
11	2462	157.036	21.96	30	Pass

Mode B
802.11b

Channel	Frequency (MHz)	Peak Power (mW)	Peak Power (dBm)	Limit (dBm)	Pass / Fail
1	2412	111.429	20.47	30	Pass
6	2437	103.753	20.16	30	Pass
11	2462	95.94	19.82	30	Pass

802.11g

Channel	Frequency (MHz)	Peak Power (mW)	Peak Power (dBm)	Limit (dBm)	Pass / Fail
1	2412	156.675	21.95	30	Pass
6	2437	166.341	22.21	30	Pass
11	2462	153.462	21.86	30	Pass

802.11n (HT20)

Channel	Frequency (MHz)	Peak Power (mW)	Peak Power (dBm)	Limit (dBm)	Pass / Fail
1	2412	136.144	21.34	30	Pass
6	2437	178.238	22.51	30	Pass
11	2462	141.906	21.52	30	Pass

4.5 Power Spectral Density Measurement

4.5.1 Limits of Power Spectral Density Measurement

The Maximum of Power Spectral Density Measurement is 8 dBm.

4.5.2 Test Setup

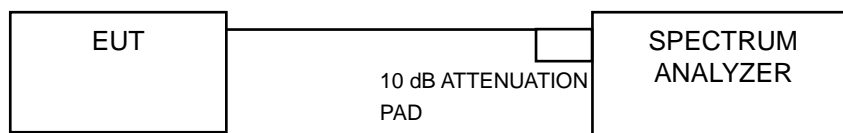

4.5.3 Test Instruments

Refer to section 4.1.2 to get information of above instrument.

4.5.4 Test Procedure

- a. Set analyzer center frequency to DTS channel center frequency.
- b. Set the span to 1.5 times the DTS bandwidth.
- c. Set the RBW to: $3 \text{ kHz} \leq \text{RBW} \leq 100 \text{ kHz}$.
- d. Set the VBW $\geq 3 \times \text{RBW}$.
- e. Detector = peak.
- f. Sweep time = auto couple.
- g. Trace mode = max hold.
- h. Allow trace to fully stabilize.
- i. Use the peak marker function to determine the maximum amplitude level within the RBW.

4.5.5 Deviation from Test Standard

No deviation.

4.5.6 EUT Operating Condition

The software provided by client to enable the EUT under transmission condition continuously at lowest, middle and highest channel frequencies individually.

4.5.7 Test Results

Mode A

802.11b

Channel	Frequency (MHz)	PSD (dBm/3 kHz)	Limit (dBm/3 kHz)	Pass / Fail
1	2412	-5.58	8	Pass
6	2437	-5.98	8	Pass
11	2462	-5.47	8	Pass

802.11g

Channel	Frequency (MHz)	PSD (dBm/3 kHz)	Limit (dBm/3 kHz)	Pass / Fail
1	2412	-9.98	8	Pass
6	2437	-9.18	8	Pass
11	2462	-9.85	8	Pass

802.11n (HT20)

Channel	Frequency (MHz)	PSD (dBm/3 kHz)	Limit (dBm/3 kHz)	Pass / Fail
1	2412	-9.66	8	Pass
6	2437	-10.53	8	Pass
11	2462	-11.58	8	Pass

Spectrum Plot of Worst Value

802.11b

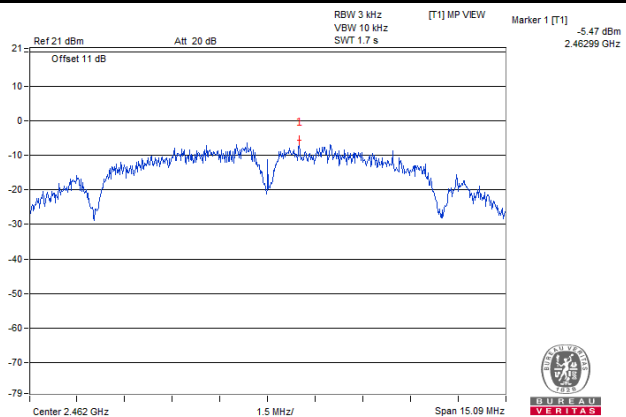

802.11g

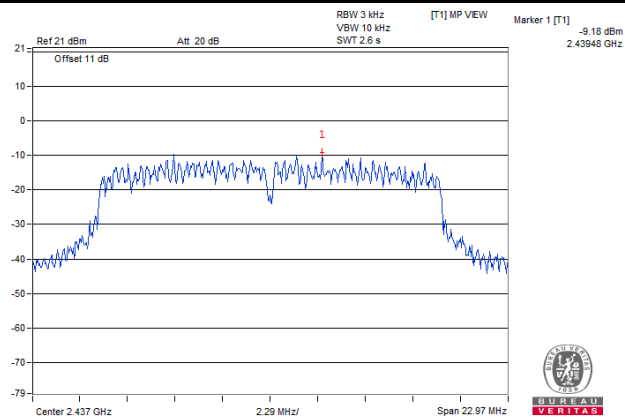

802.11n (HT20)

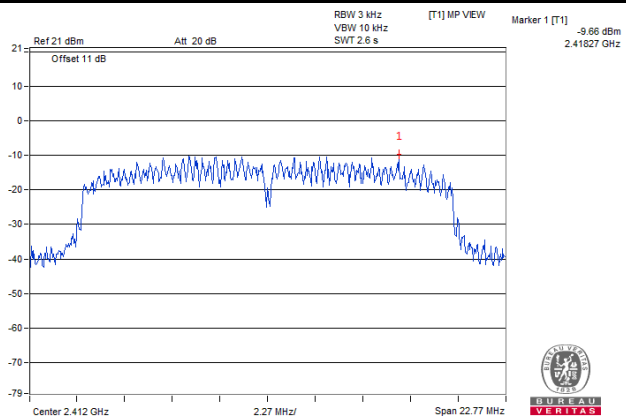

Mode B
802.11b

Channel	Frequency (MHz)	PSD (dBm/3 kHz)	Limit (dBm/3 kHz)	Pass / Fail
1	2412	-5.58	8	Pass
6	2437	-5.98	8	Pass
11	2462	-5.47	8	Pass

802.11g

Channel	Frequency (MHz)	PSD (dBm/3 kHz)	Limit (dBm/3 kHz)	Pass / Fail
1	2412	-9.98	8	Pass
6	2437	-9.18	8	Pass
11	2462	-9.85	8	Pass

802.11n (HT20)

Channel	Frequency (MHz)	PSD (dBm/3 kHz)	Limit (dBm/3 kHz)	Pass / Fail
1	2412	-9.66	8	Pass
6	2437	-10.53	8	Pass
11	2462	-11.58	8	Pass

Spectrum Plot of Worst Value

802.11b

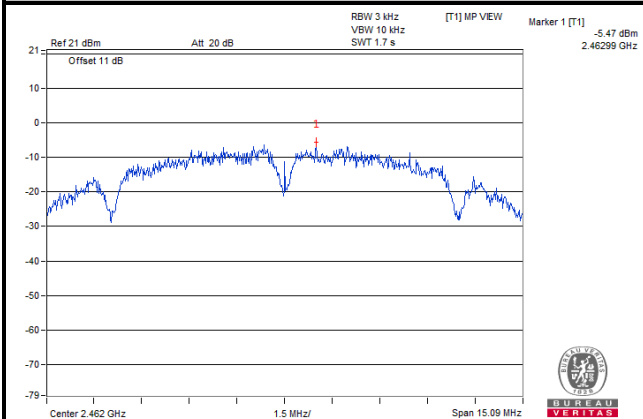

802.11g

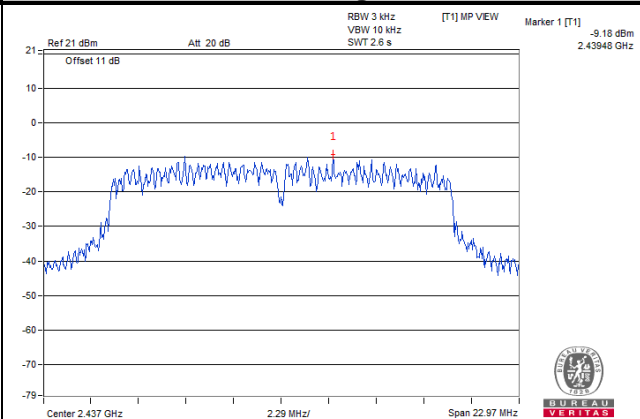

802.11n (HT20)

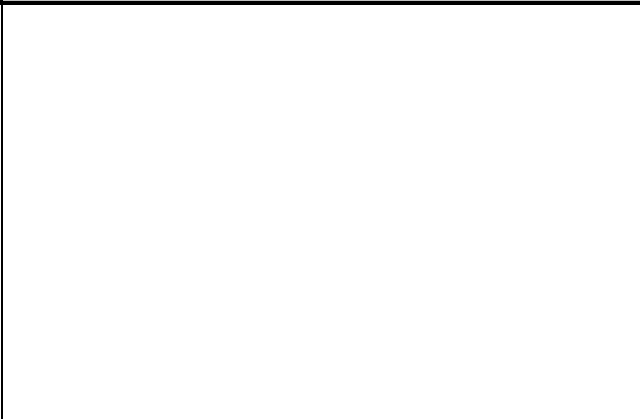
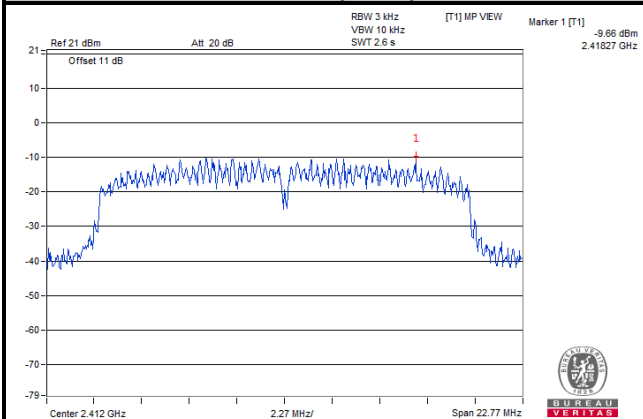

4.6 Conducted Out of Band Emission Measurement

4.6.1 Limits of Conducted Out of Band Emission Measurement

Below 20 dB of the highest emission level of operating band (in 100 kHz Resolution Bandwidth).

4.6.2 Test Setup

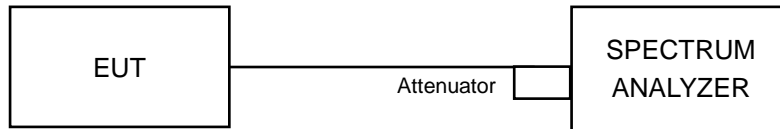

4.6.3 Test Instruments

Refer to section 4.1.2 to get information of above instrument.

4.6.4 Test Procedure

MEASUREMENT PROCEDURE REF

1. Set the RBW = 100 kHz.
2. Set the VBW \geq 300 kHz.
3. Detector = peak.
4. Sweep time = auto couple.
5. Trace mode = max hold.
6. Allow trace to fully stabilize.
7. Use the peak marker function to determine the maximum power level in any 100 kHz band segment within the fundamental EBW.

MEASUREMENT PROCEDURE OOB

1. Set RBW = 100 kHz.
2. Set VBW \geq 300 kHz.
3. Detector = peak.
4. Sweep = auto couple.
5. Trace Mode = max hold.
6. Allow trace to fully stabilize.
7. Use the peak marker function to determine the maximum amplitude level.

4.6.5 Deviation from Test Standard

No deviation.

4.6.6 EUT Operating Condition

The software provided by client to enable the EUT under transmission condition continuously at lowest, middle and highest channel frequencies individually.

4.6.7 Test Results

The spectrum plots are attached on the following images. D1 line indicates the highest level, and D2 line indicates the 20 dB offset below D1. It shows compliance with the requirement.

Mode A

802.11b

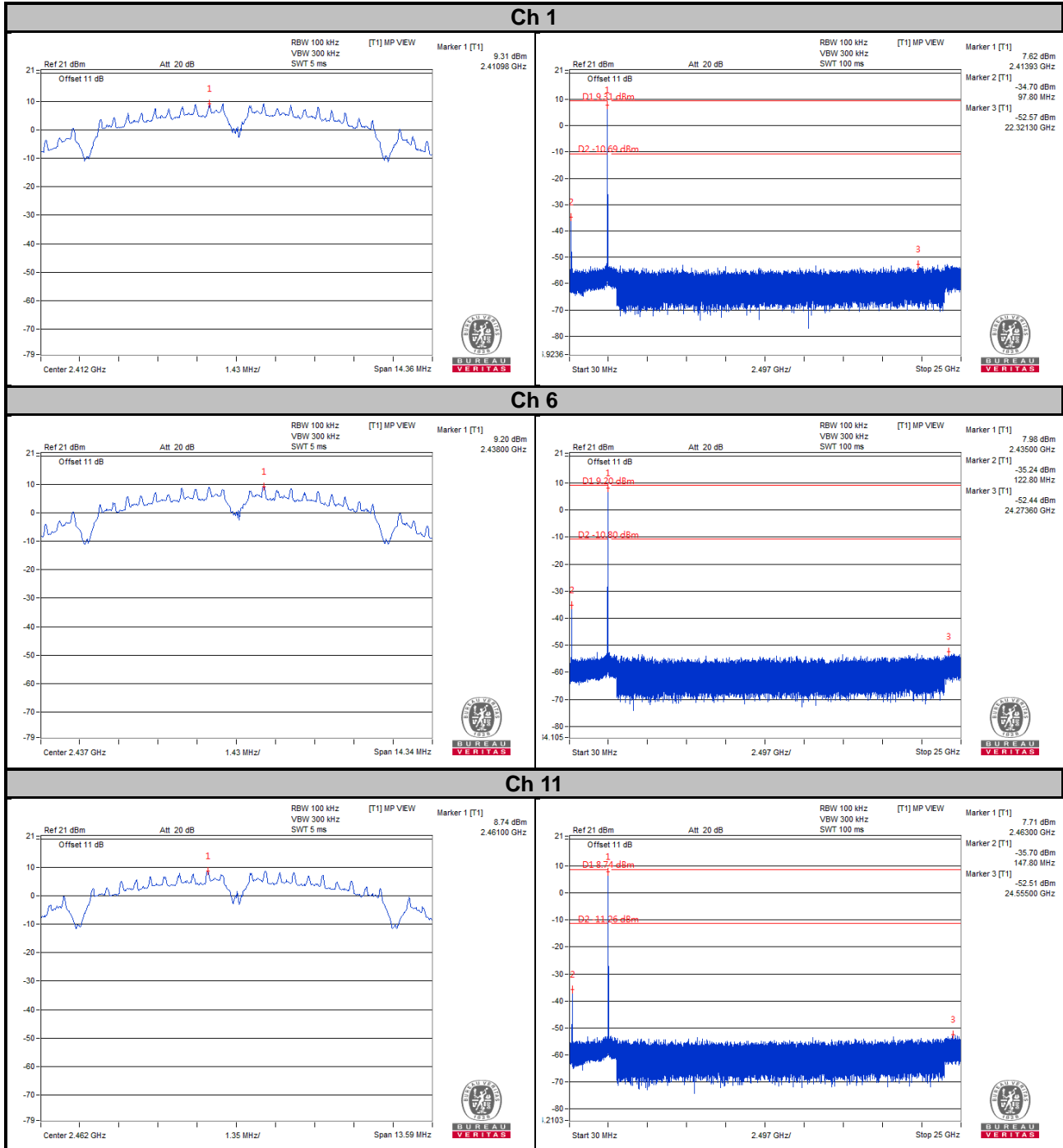

Ch 1 Band Edge

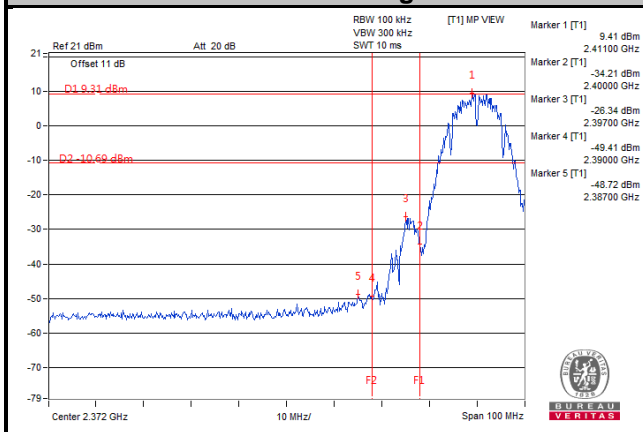

Ch 11 Band Edge

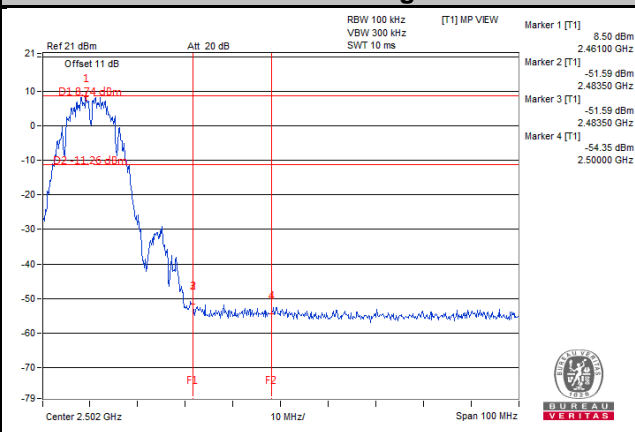

802.11g

Ch 1

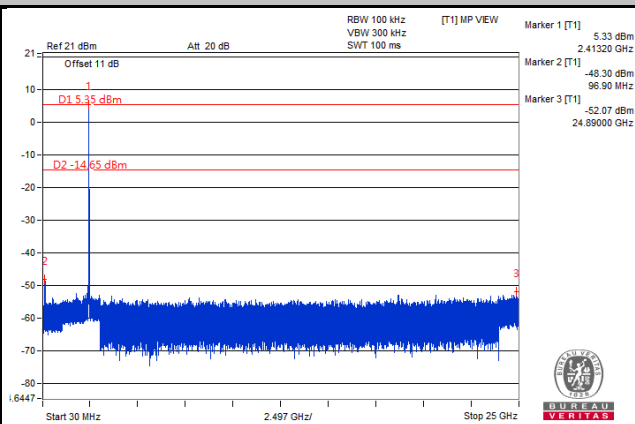
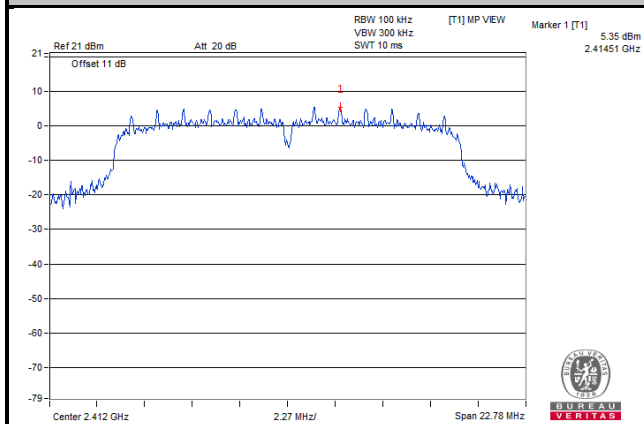

Ch 6

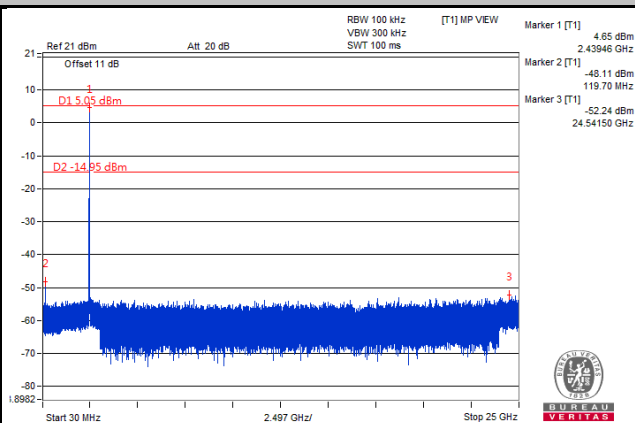
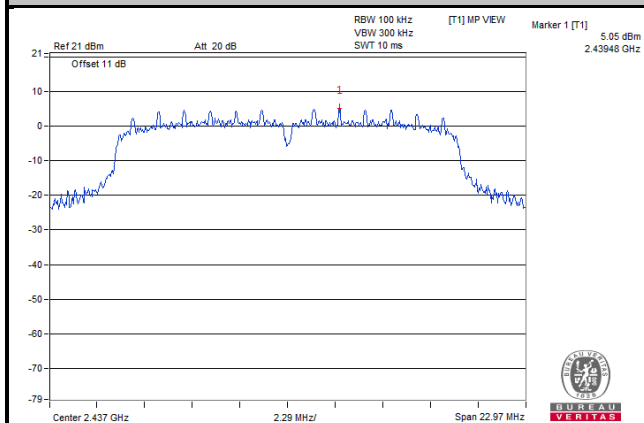

Ch 11

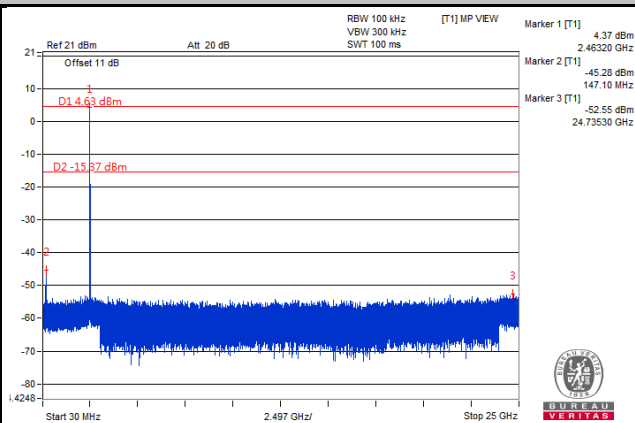
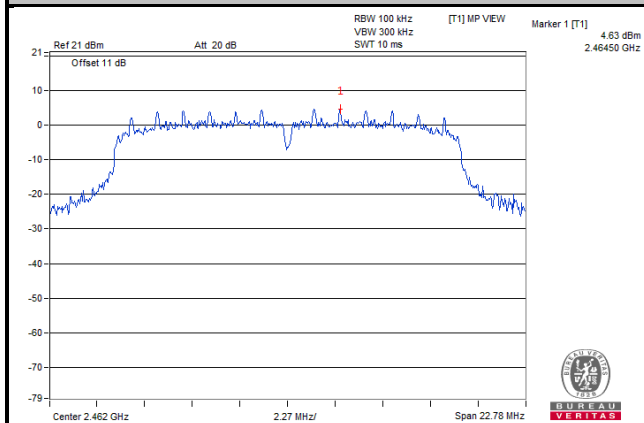

Ch 1 Band Edge

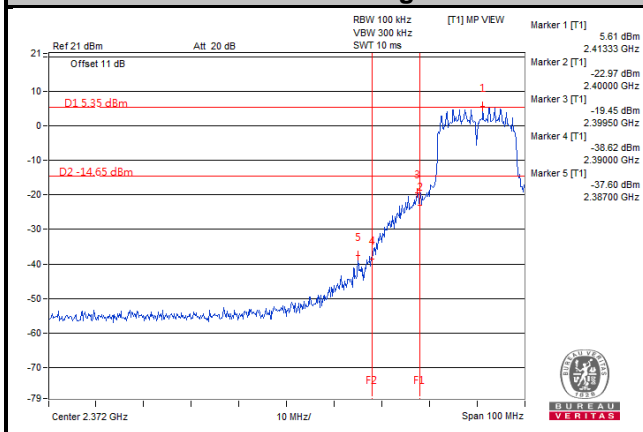

Ch 11 Band Edge

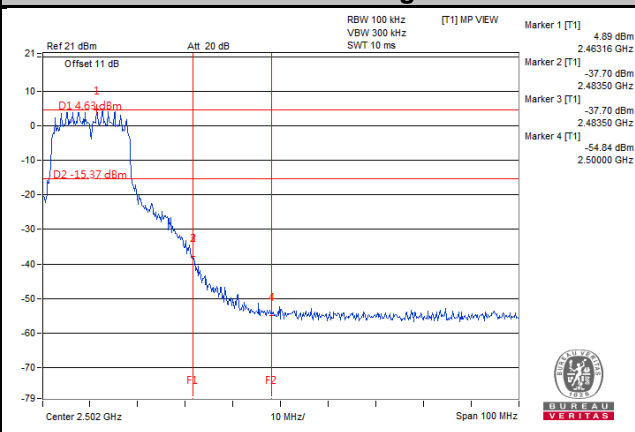

802.11n (HT20)

Ch 1

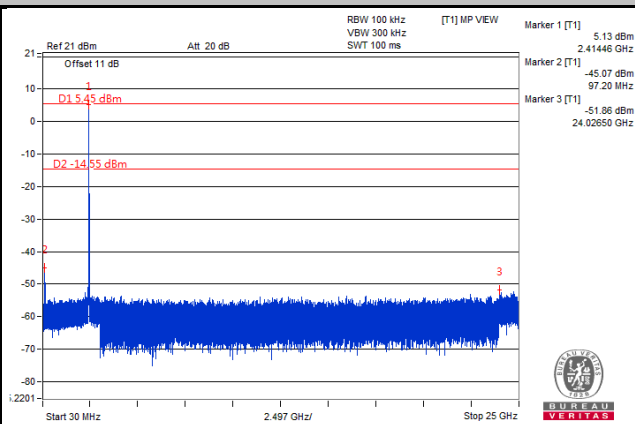
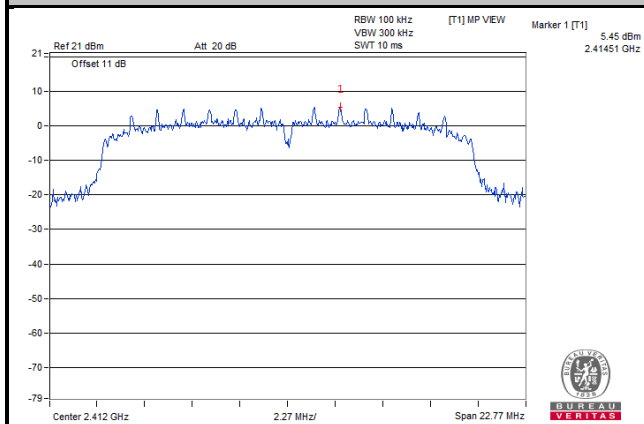

Ch 6

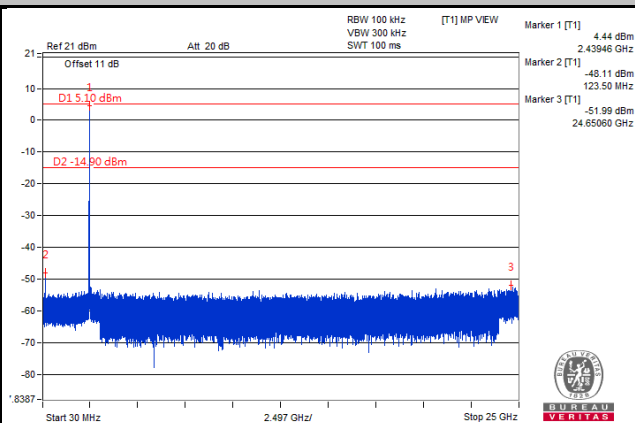
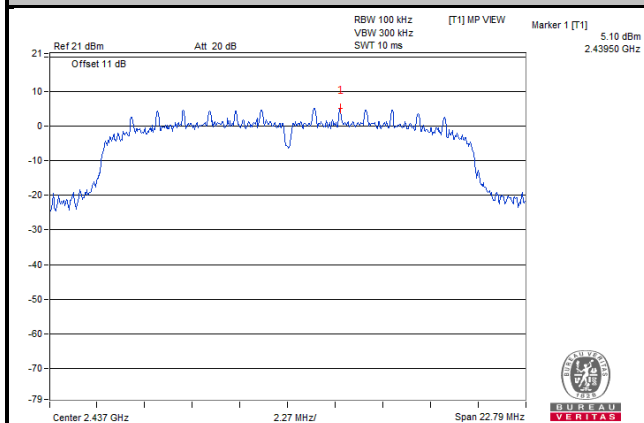

Ch 11

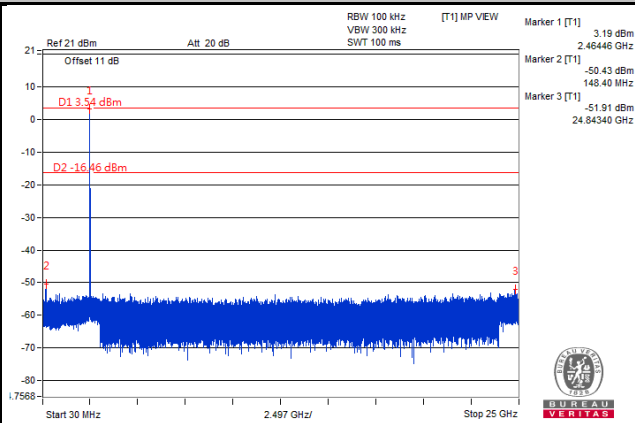
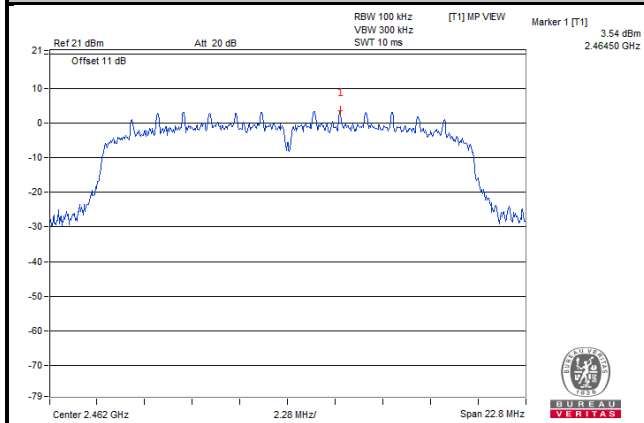

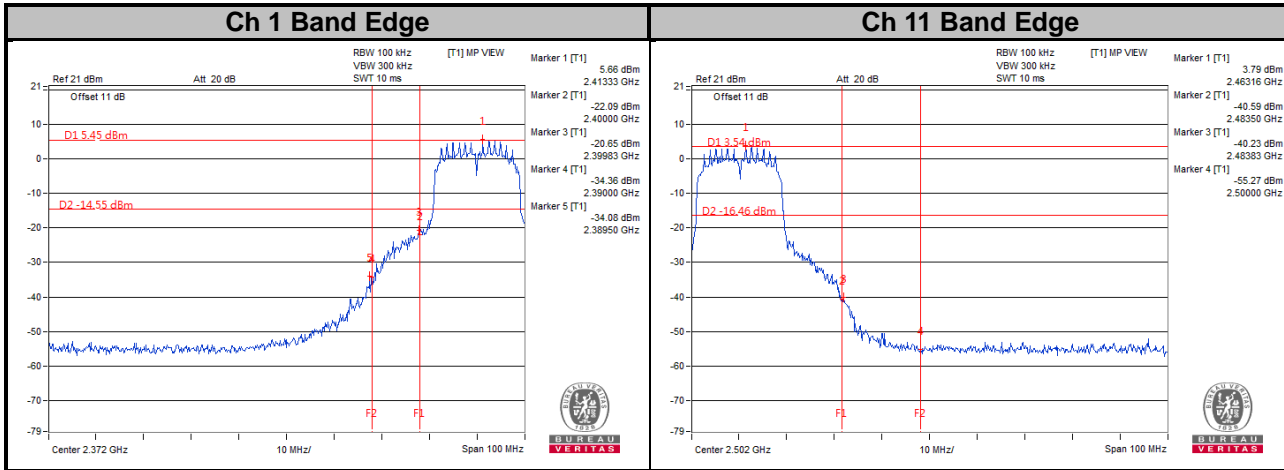

Mode B
802.11b

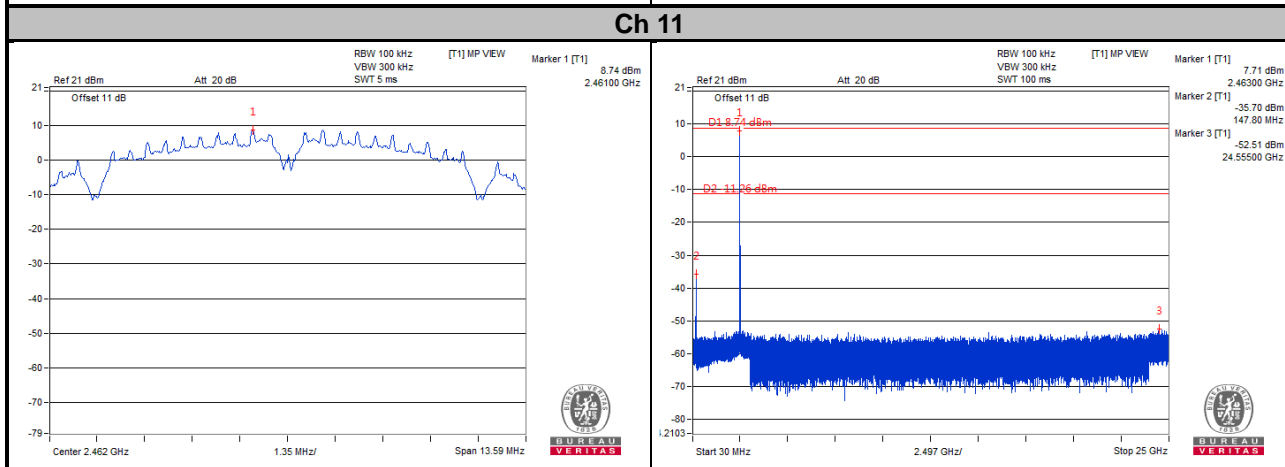
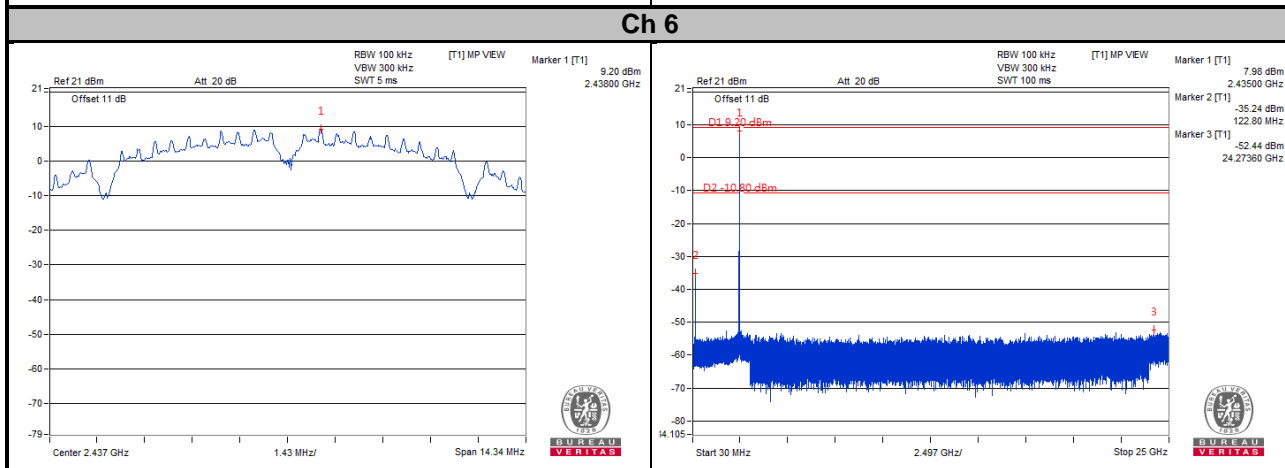
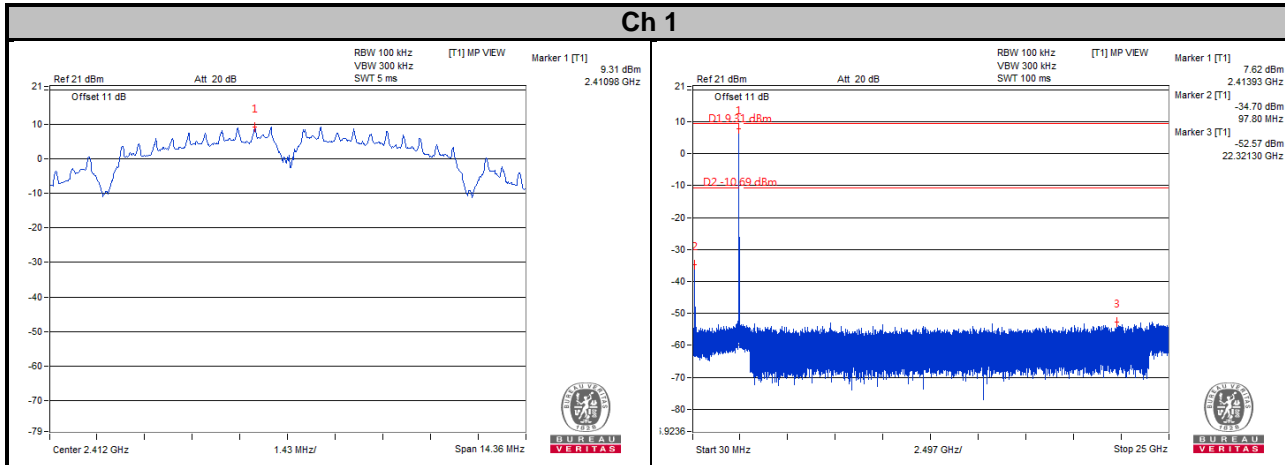

Ch 1 Band Edge

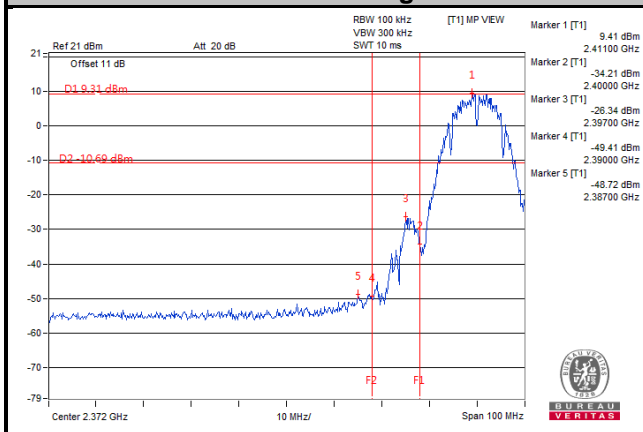

Ch 11 Band Edge

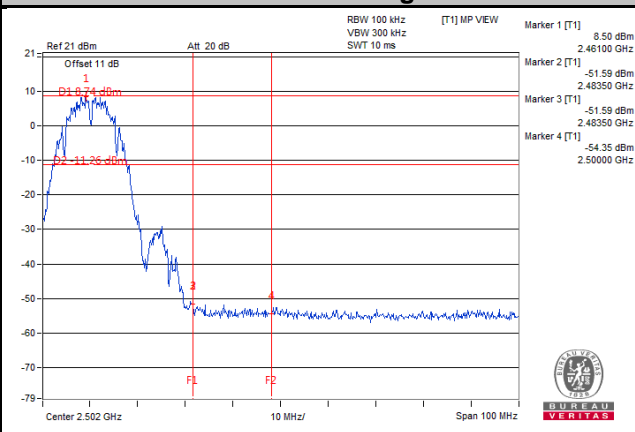

802.11g

Ch 1

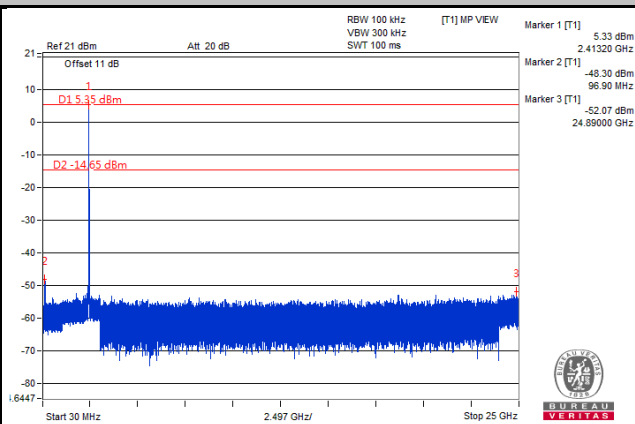
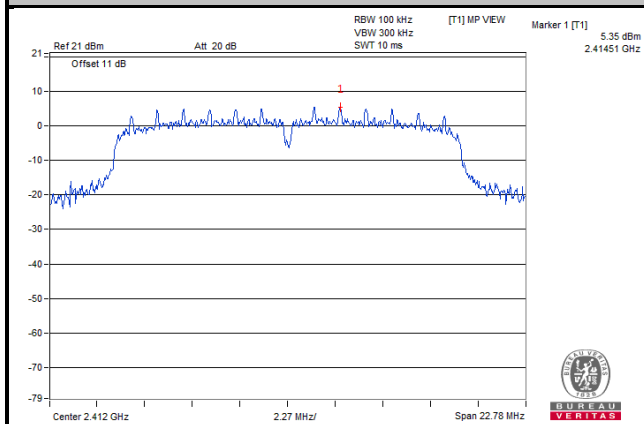

Ch 6

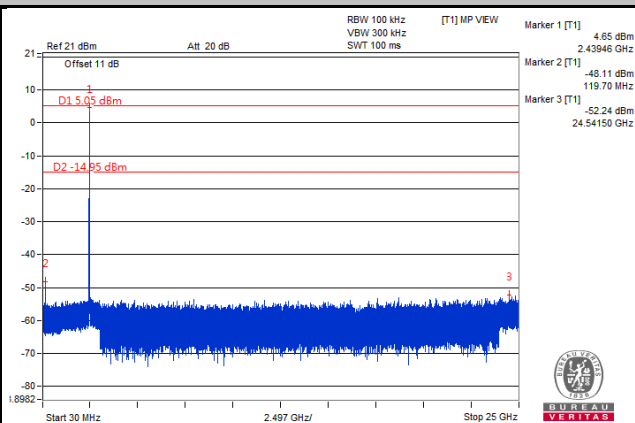
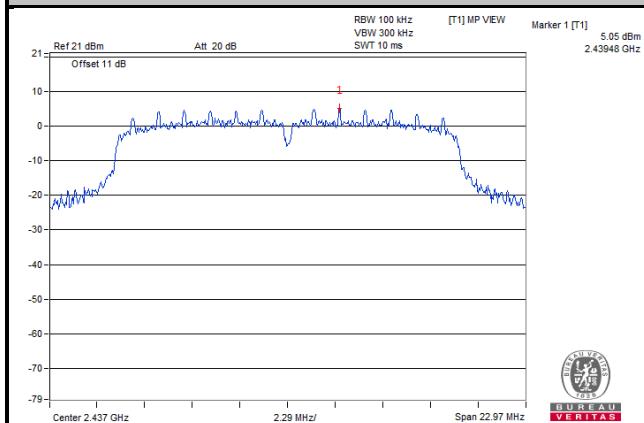

Ch 11

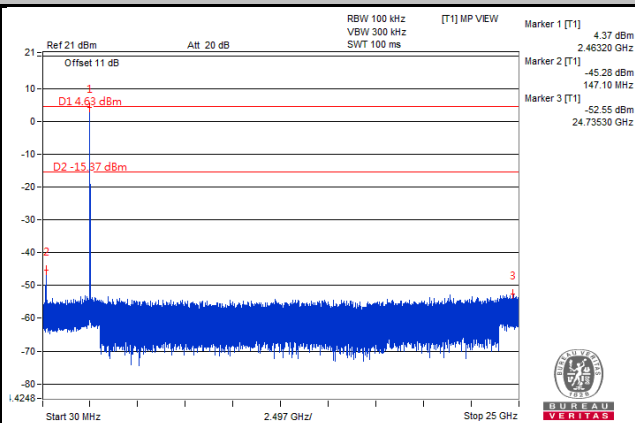
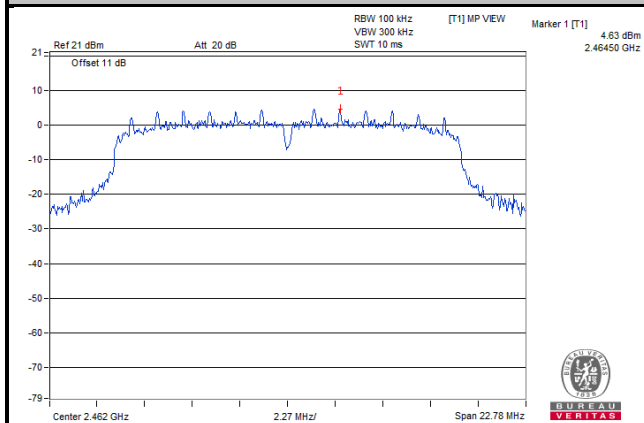

Ch 1 Band Edge

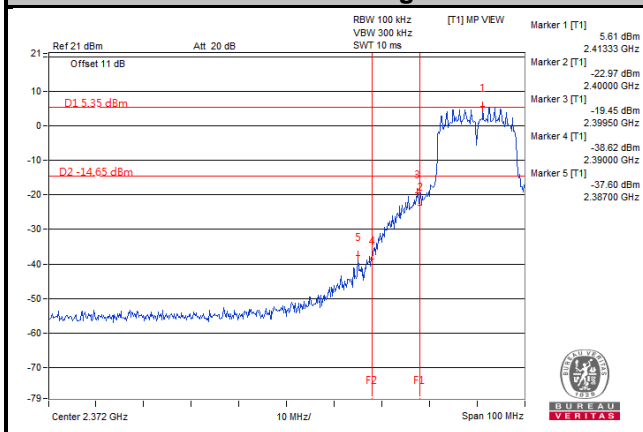

Ch 11 Band Edge

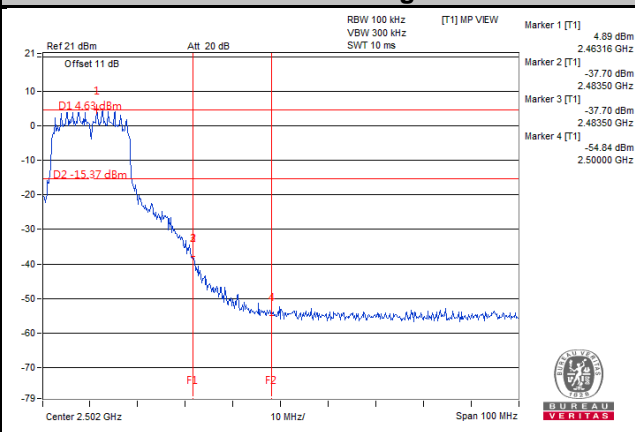

802.11n (HT20)

Ch 1

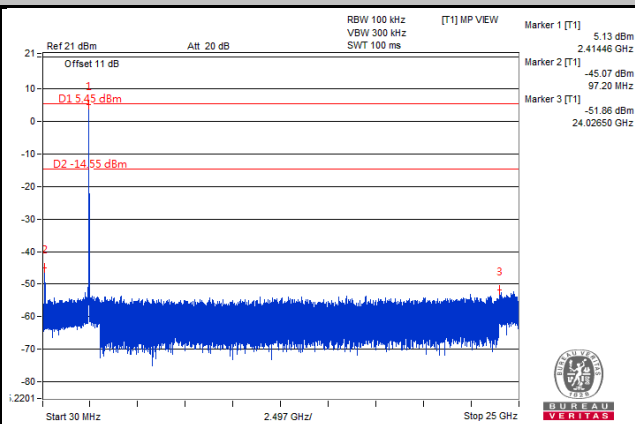
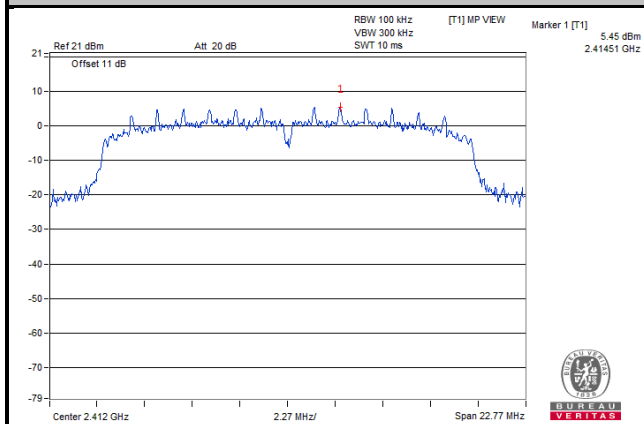

Ch 6

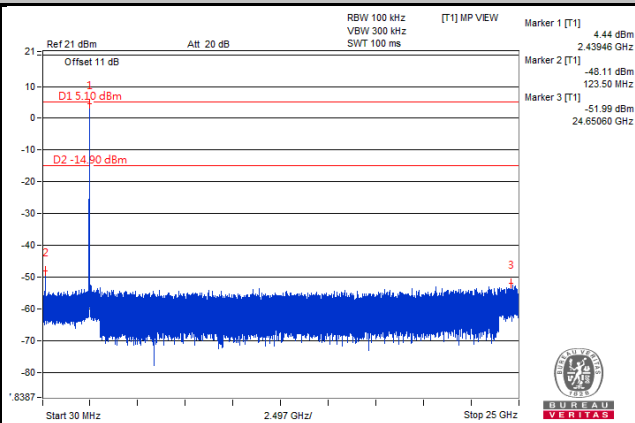
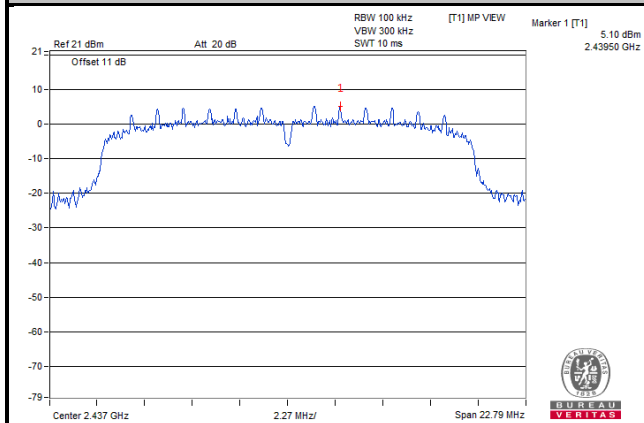

Ch 11

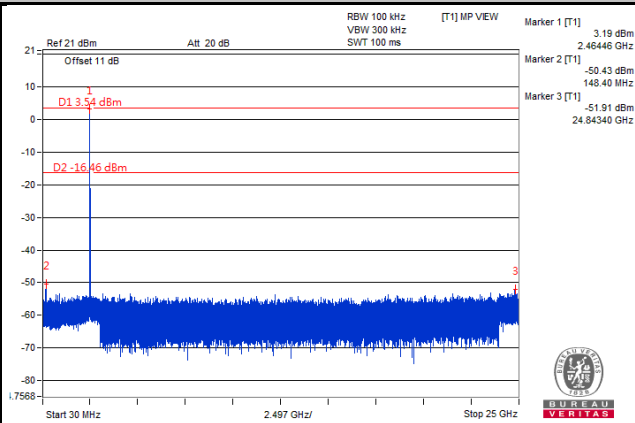
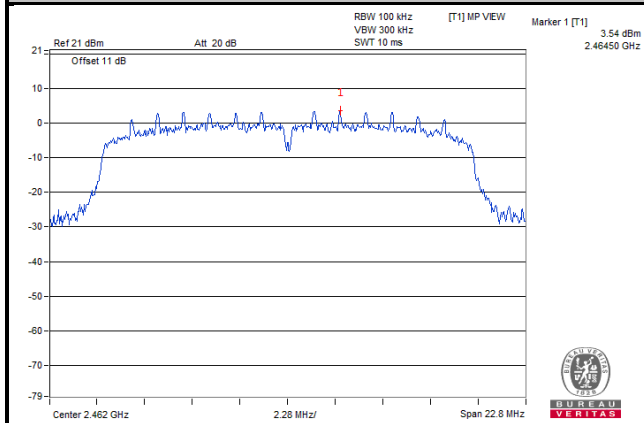

Ch 1 Band Edge

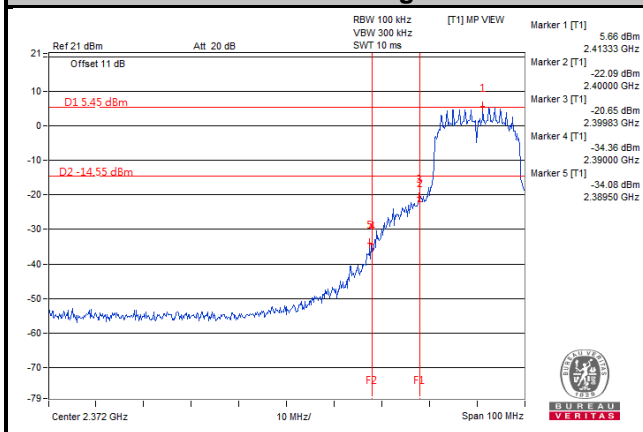

Ch 11 Band Edge

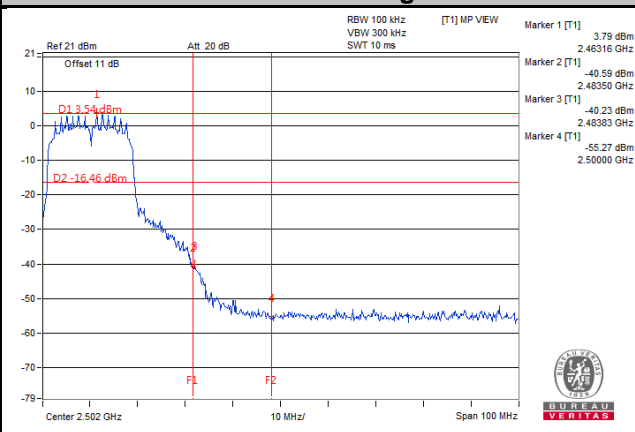

5 Pictures of Test Arrangements

Please refer to the attached file (Test Setup Photo).

Appendix – Information on the Testing Laboratories

We, Bureau Veritas Consumer Products Services (H.K.) Ltd., Taoyuan Branch, were founded in 1988 to provide our best service in EMC, Radio, Telecom and Safety consultation. Our laboratories are FCC recognized accredited test firms and accredited according to ISO/IEC 17025.

If you have any comments, please feel free to contact us at the following:

Linko EMC/RF Lab

Tel: 886-2-26052180

Fax: 886-2-26051924

Hsin Chu EMC/RF/Telecom Lab

Tel: 886-3-6668565

Fax: 886-3-6668323

Hwa Ya EMC/RF/Safety Lab

Tel: 886-3-3183232

Fax: 886-3-3270892

Email: service.adt@tw.bureauveritas.com

Web Site: www.bureauveritas-adt.com

The address and road map of all our labs can be found in our web site also.

--- END ---