

# SMART sketcher<sup>®</sup>

## USER MANUAL

# CAUTION- ELECTRIC TOY:

Not recommended for children under 3 years of ages. As with all electric products, precautions should be observed during handling and use to prevent electric shock.

AC adapter: INPUT: 100-240VAC, 0.3A MAX 50/60Hz;  
OUTPUT: 5.9V 1.0A

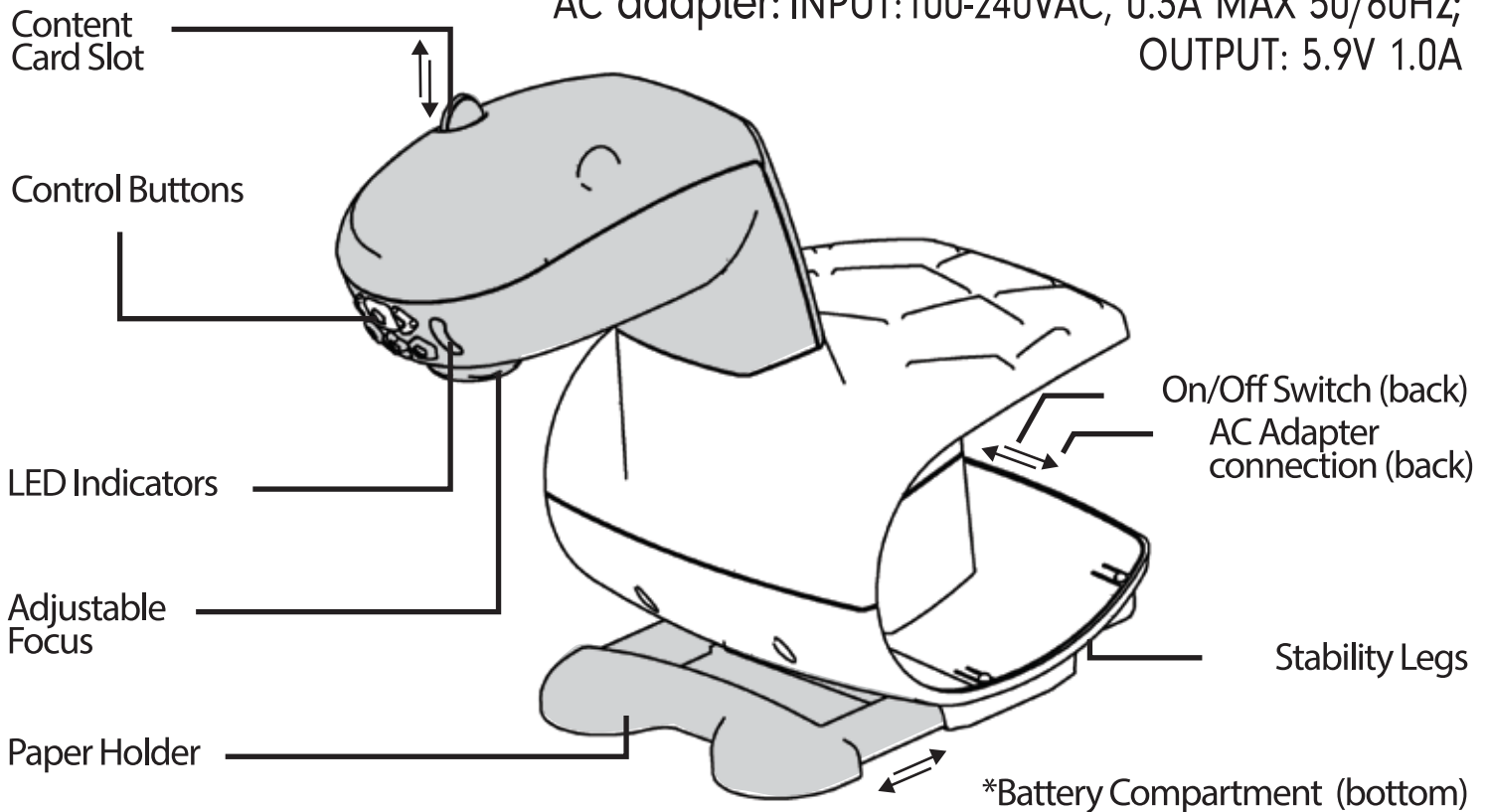

## SIMPLE SETUP

1. Separate the blue projector head from the white base unit.
2. Insert blue unit into top of white base until you hear a click.
3. Plug the AC adapter (included) into the back of the unit and into a power outlet. If you wish to use batteries instead, insert 4 D batteries (not included) according to the directions below.  
Enable "efficiency mode" by pressing the blue circle button for 2 seconds.
4. Pull out the blue legs to stabilize the projector and create a paper holder.
5. Flip the switch on the back to turn on the projector.
6. Insert the pre-loaded activity pack into the top of the projector.
7. After 10 minutes with no activity the projector light will automatically turn off. Reactivate the light by using the buttons in the app or on the projector.

For more fun, additional Creativity and Learn-A- Language Alphabet Packs are available at: [www.smartsketcher.com](http://www.smartsketcher.com).

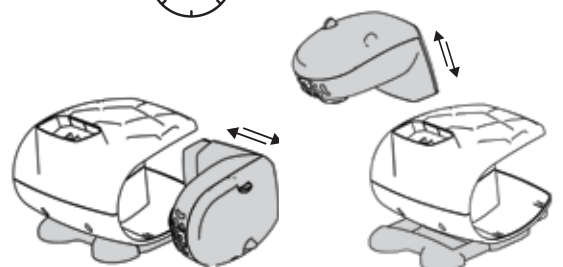
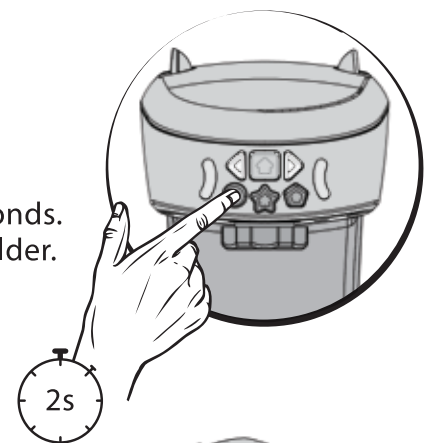

**WARNING:**  
**CHOKING HAZARD**-Small parts.  
Not for children under 3 years.

The toy should be periodically examined for potential hazardous parts to be repaired or replaced.

# QUICK START

1. Download the "smART sketcher Projector" app on your mobile device or tablet.
2. Open the app and enable Bluetooth on your device.
3. **If you haven't registered yet:** Click the "I have a smART sketcher" button and follow the instructions to complete the one-time registration process.  
**If you have already registered:** Click the "Login with Flycatcher ID" link.
4. Once the device is connected to the projector, choose your mode of play: Learn to Draw (pre-loaded activity card), or Trace Pictures (taken from your own device).

Requires Android 5.0+  
Requires Apple iOS 8.0+



## 5. Trace Pictures:

- Click the camera button (you will need to enable permission for access to camera and photos)
- Select an image from your photos or take your own using the in-app camera.
- Select a filter.
- Drag the slider button to adjust darkness.
- Press the "check" button to transfer the image to the smART sketcher® Projector.
- Begin tracing on paper.

## 6. Learn to Draw:

- Insert the preloaded activity card or a smART sketcher Creativity Pack (purchased separately) into the top of the projector.
- The app will display the loaded content.
- Scroll to find the image you want to draw and select it.
- The image will be projected onto your paper.
- Begin drawing!

## CONTROL BUTTONS

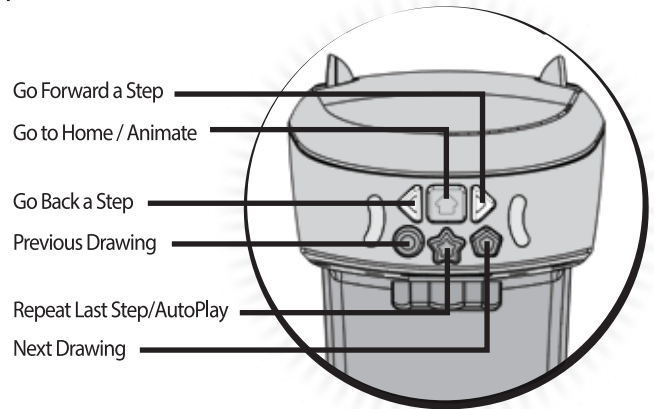

# SAFETY INFORMATION

### BATTERY SAFETY INFORMATION

In exceptional circumstances batteries may leak fluids that can cause a chemical burn injury or ruin your product.  
To avoid battery leakage:  
Non-rechargeable batteries are not to be recharged.  
Rechargeable batteries are to be removed from the toy before being charged.  
Rechargeable batteries are only to be charged under adult supervision.  
Do not mix alkaline, standard (carbon-zinc), or rechargeable (nickel-cadmium) batteries.  
Do not mix old and new batteries.  
Only batteries of the same or equivalent types as recommended to be used.  
Batteries are to be inserted with correct polarity.  
Exhausted batteries are to be removed from the product.  
The supply terminals are not to be short circuited.  
Dispose of battery(ies) safely.  
Do not dispose of this product in a fire.

### BATTERY INSTALLATION

To insert or change the batteries, twist the screw counter-clockwise to loosen. Remove old batteries and insert 4 D batteries with the correct polarity. Replace the screw and twist clockwise to close.

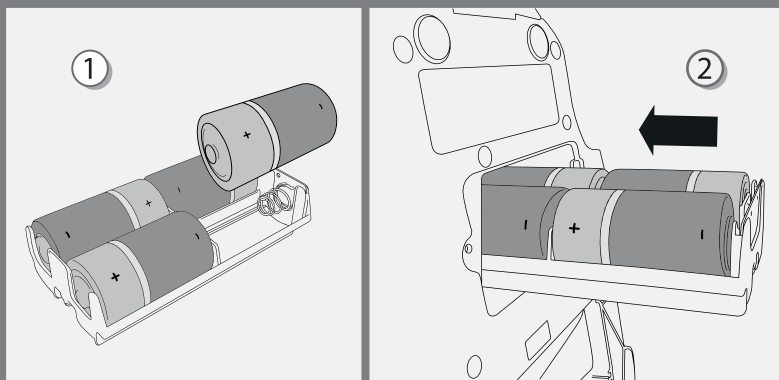

### AC ADAPTER:

Transformers / charger used with the toy are to be regularly examined for damage to the cord, plug, enclosure and other parts, and that, in the event of such damage, the toy must not be used with this transformer/charger until the damage has been repaired.  
The toy is not intended for children under 3 years old;  
1) The toy shall only be used with a transformer for toys  
2) The model number XY06J-0601000Q-EW (EU only)/ XY06J-0601000Q-BW (UK only)/ XY06S-0601000Q-UW/XY06S-0591000Q-UW/ XY-0601000-A (Aus-NZ only) or specification of Input Voltage: AC 100-240V 50-60 Hz, Output Voltage: DC 5.9V, 1A, transformer for use with the toy  
3) The transformer is not a toy;  
4) Toys liable to be cleaned with liquid are to be disconnected from the transformer before cleaning.

### RADIO STATEMENT

**Warning:** Changes or modifications to this unit not expressly approved by the party responsible for compliance could void the user's authority to operate the equipment.  
This device complies with Part 15 of the FCC Rules. Operation is subject to the following two conditions: (1) this device may not cause harmful interference, and (2) this device must accept any interference received, including interference that may cause undesired operation.  
This device contains licence-exempt transmitter(s)/receiver(s) that comply with Innovation, Science and Economic Development Canada's licence-exempt RSS(s). Operation is subject to the following two conditions: (1) This device may not cause interference. (2) This device must accept any interference, including interference that may cause undesired operation of the device

**Note:**  
This equipment has been tested and found to comply with the limits for a Class B digital device, pursuant to part 15 of the FCC Rules. These limits are designed to provide reasonable protection against harmful interference in a residential installation. This equipment generates, uses and can radiate radio frequency energy and, if not installed and used in accordance with the instructions, may cause harmful interference to radio communications. However, there is no guarantee that interference will not occur in a particular installation. If this equipment does cause harmful interference to radio or television reception, which can be determined by turning the equipment off and on, the user is encouraged to try to correct the interference by one or more of the following measures:  
- Reorient or relocate the receiving antenna.  
- Increase the separation between the equipment and receiver.  
- Connect the equipment into an outlet on a circuit different from that to which the receiver is connected.  
- Consult the dealer or an experienced radio/TV technician for help.



smART sketcher® is a trademark of Flycatcher Inc.  
Copyright © 2017 Flycatcher Inc.  
All rights reserved.  
Visit us at:  
[www.smARTsketcher.com](http://www.smARTsketcher.com)

For more detailed instructions, questions or problems, please visit [www.smartsketcher.com](http://www.smartsketcher.com).