

FCC TEST REPORT

**Test report
On Behalf of
R-Go Tools BV
For
R-GO HE MOUSE LARGE WIRELESS
Model No.: RGOHELAWL

FCC ID: 2AMPY-RGOHELAWL**

Prepared for : R-Go Tools BV
Technieweg 15, 4143 HW, Leerdam, Netherlands

Prepared By : Laboratory of Shenzhen United Testing Technology Co., Ltd
Room 316-319, Block B, Honghualing Industrial Park of the Fifth Zone, Taoyuan
Street, Nanshan District, Shenzhen, Guangdong, China

Date of Test: Jun. 20, 2017 ~ Jun. 26, 2017
Date of Report: Jun. 26, 2017
Report Number: UNI170620046-E

TEST RESULT CERTIFICATION

Applicant's name : R-Go Tools BV
 Address : Technieweg 15, 4143 HW, Leerdam, Netherlands
Manufacture's Name..... : R-Go Tools BV
 Address : Technieweg 15, 4143 HW, Leerdam, Netherlands

Product description

Trade Mark: **R-Go Tools**
 Product name : R-GO HE MOUSE LARGE WIRELESS
 Model and/or type reference : RGOHELAWL

Standards : FCC Rules and Regulations Part 15 Subpart C Section 15.249
 ANSI C63.10: 2013

This publication may be reproduced in whole or in part for non-commercial purposes as long as the **Laboratory of Shenzhen United Testing Technology Co., Ltd** is acknowledged as copyright owner and source of the material. **Laboratory of Shenzhen United Testing Technology Co., Ltd** takes no responsibility for and will not assume liability for damages resulting from the reader's interpretation of the reproduced material due to its placement and context.

Date of Test :
 Date (s) of performance of tests : **Jun. 20, 2017 ~ Jun. 26, 2017**
 Date of Issue..... : **Jun. 26, 2017**
 Test Result..... : **Pass**

Testing Engineer : 

 (Eric Xie)

Technical Manager : 

 (Dora Qin)

Authorized Signatory : 

 (Kait Chen)

Table of Contents	Page
1 . TEST SUMMARY	4
2 . GENERAL INFORMATION	5
2.1 GENERAL DESCRIPTION OF EUT	5
2.2 Operation of EUT during testing	6
2.3 DESCRIPTION OF TEST SETUP	6
2.4 MEASUREMENT INSTRUMENTS LIST	7
3 . CONDUCTED EMISSIONS TEST	8
3.1 Conducted Power Line Emission Limit	8
3.2 Test Setup	8
3.3 Test Procedure	8
3.4 Test Result	8
4 RADIATED EMISSION TEST	11
4.1 Radiation Limit	11
4.2 Test Setup	11
4.3 Test Procedure	12
4.4 Test Result	12
5 BAND EDGE	18
5.1 Limits	18
5.2 Test Procedure	18
5.3 Test Result	18
6 OCCUPIED BANDWIDTH MEASUREMENT	20
6.1 Test Setup	20
6.2 Test Procedure	20
6.3 Measurement Equipment Used	20
6.4 Test Result	20
7 ANTENNA REQUIREMENT	22
8 PHOTOGRAPH OF TEST	23
8.1 Radiated Emission	23
8.2 Conducted Emission	24

1. TEST SUMMARY

1.1 TEST PROCEDURES AND RESULTS

DESCRIPTION OF TEST	RESULT
CONDUCTED EMISSIONS TEST	COMPLIANT
RADIATED EMISSION TEST	COMPLIANT
BAND EDGE	COMPLIANT
OCCUPIED BANDWIDTH MEASUREMENT	COMPLIANT
ANTENNA REQUIREMENT	COMPLIANT

1.2 TEST FACILITY

Test Firm : QTC Certification & Testing Co., Ltd.
Certificated by FCC, Registration No.: 588523
Address : 2nd Floor,B1 Building,Fengyeyuan Industrial Plant, Liuxian 2st. Road,
Xin'an Street, Bao'an District, Shenzhen, China

1.3 MEASUREMENT UNCERTAINTY

Measurement Uncertainty	
Conducted Emission Expanded Uncertainty	= 2.23dB, k=2
Radiated emission expanded uncertainty(9kHz-30MHz)	= 3.08dB, k=2
Radiated emission expanded uncertainty(30MHz-1000MHz)	= 4.42dB, k=2
Radiated emission expanded uncertainty(Above 1GHz)	= 4.06dB, k=2

2. GENERAL INFORMATION

2.1 GENERAL DESCRIPTION OF EUT

Equipment	R-GO HE MOUSE LARGE WIRELESS
Model Name	RGOHELAWL
Serial Model	/
Model Difference	/
FCC ID	2AMPY-RGOHELAWL
Antenna Type	PCB Antenna
Antenna Gain	0dBi
BT Operation frequency	2407-2477MHz
Number of Channels	16CH
Modulation Type	GFSK
Power Source	DC Voltage
Power Rating	DC 3.7 V for battery or DC 5V form Adapter

2.1.1 Carrier Frequency of Channels

Channel List					
Channel	Frequency (MHz)	Channel	Frequency (MHz)	Channel	Frequency (MHz)
00	2407	07	2437	14	2469
01	2408	08	2440	15	2477
02	2410	09	2441	/	/
03	2414	10	2442	/	/
04	2421	11	2455	/	/
05	2428	12	2467	/	/
06	2435	13	2468	/	/

2.2 Operation of EUT during testing

Operating Mode

The mode is used: **Transmitting mode**

Low Channel: 2407MHz

Middle Channel: 2440MHz

High Channel: 2477MHz

2.3 DESCRIPTION OF TEST SETUP

Operation of EUT during conducted testing:

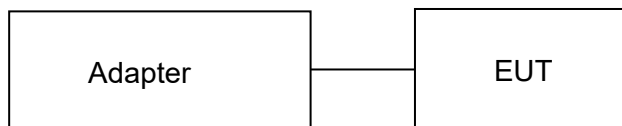

Operation of EUT during radiation testing:



2.4 MEASUREMENT INSTRUMENTS LIST

Item	Equipment	Manufacturer	Model No.	Serial No.	Cal Date	Due Date
1.	EMI Receiver	Rohde & Schwarz	ESCI	100627	Feb. 18, 2017	Feb. 17, 2018
2.	LISN	SchwarzBeck	NSLK 8126	8126377	Feb. 18, 2017	Feb. 17, 2018
3.	RF Switching Unit	Compliance Direction	RSU-M2	38303	Feb. 18, 2017	1 Year
4.	EMI Test Software ES-K1	Rohde & Schwarz	N/A	N/A	N/A	N/A
5.	EMI Test Receiver	Rohde & Schwarz	ESCI	100627	Feb. 18, 2017	Feb. 17, 2018
6.	Trilog Broadband Antenna	Schwarzbeck	VULB9163	VULB 9163-289	Feb. 18, 2017	Feb. 17, 2018
7.	Pre-amplifier	Compliance Direction	PAP-0203	22008	Feb. 18, 2017	Feb. 17, 2018
8.	EMI Test Software EZ-EMC	SHURPLE	N/A	N/A	N/A	N/A
9.	EMI Receiver	Rohde & Schwarz	ESCI	100627	Feb. 18, 2017	Feb. 17, 2018
10.	LISN	SchwarzBeck	NSLK 8126	8126377	Feb. 18, 2017	Feb. 17, 2018
11.	RF Switching Unit	Compliance Direction	RSU-M2	38303	Feb. 18, 2017	Feb. 17, 2018
12.	EMI Test Software ES-K1	Rohde & Schwarz	N/A	N/A	N/A	N/A
13.	EMI Receiver	Rohde & Schwarz	ESCI	100627	Feb. 18, 2017	Feb. 17, 2018
14.	EMI Receiver	Rohde & Schwarz	ESCI	100627	Feb. 18, 2017	Feb. 17, 2018
15.	LISN	SchwarzBeck	NSLK 8126	8126377	Feb. 18, 2017	Feb. 17, 2018
16.	RF Switching Unit	Compliance Direction	RSU-M2	38303	Feb. 18, 2017	Feb. 17, 2018
17.	EMI Test Software ES-K1	Rohde & Schwarz	N/A	N/A	N/A	N/A
18.	Power Meter	R&S	NRVD	SEL0069	Feb. 18, 2017	Feb. 17, 2018
19.	Power Sensor	R&S	URV5-Z2	SEL0071	Feb. 18, 2017	Feb. 17, 2018
20.	Power Sensor	R&S	URV5-Z2	SEL0072	Feb. 18, 2017	Feb. 17, 2018
21.	Software EMC32	R&S	EMC32-S	SEL0082	N/A	N/A
22.	Log-periodic Antenna	Amplifier Reasearch	APT1.580	SEL0073	Feb. 18, 2017	Feb. 17, 2018
23.	Loop Antenna	Schwarz beck	FMZB 1516	9773	Feb. 18, 2017	Feb. 17, 2018
24.	Broadband Antenna	Schwarz beck	VULB9163	9163-333	Feb. 18, 2017	Feb. 17, 2018
25.	Horn Antenna	ETS	3117	00086197	Feb. 18, 2017	Feb. 17, 2018
26.	Horn Antenna	Schwarzbeck	BBHA9170	BBHA91705 82	Feb. 18, 2017	Feb. 17, 2018
27.	Antenna Tripod	Amplifier Reasearch	TP1000A	SEL0074	Feb. 18, 2017	Feb. 17, 2018
28.	High Gain Horn Antenna	Amplifier Reasearch	AT4002A	SEL0075	Feb. 18, 2017	Feb. 17, 2018
29.	Spectrum analyzer	Agilent	N9020A	MY49911004 8	Feb. 18, 2017	Feb. 17, 2018
30.	Spectrum analyzer	Agilent	E4407B	MY46184326	Feb. 18, 2017	Feb. 17, 2018
31.	Spectrum analyzer	R&S	FSP30	836079/035	Feb. 18, 2017	Feb. 17, 2018
32.	RF Cable	Micable	C10-01-01-1	100309	Feb. 18, 2017	Feb. 17, 2018

3. CONDUCTED EMISSIONS TEST

3.1 Conducted Power Line Emission Limit

For unintentional device, according to § 15.107(a) Line Conducted Emission Limits is as following

Frequency (MHz)	Maximum RF Line Voltage (dBµV)			
	CLASS A		CLASS B	
	Q.P.	Ave.	Q.P.	Ave.
0.15 - 0.50	79	66	66-56*	56-46*
0.50 - 5.00	73	60	56	46
5.00 - 30.0	73	60	60	50

* Decreasing linearly with the logarithm of the frequency

For intentional device, according to §15.207(a) Line Conducted Emission Limit is same as above table.

3.2 Test Setup

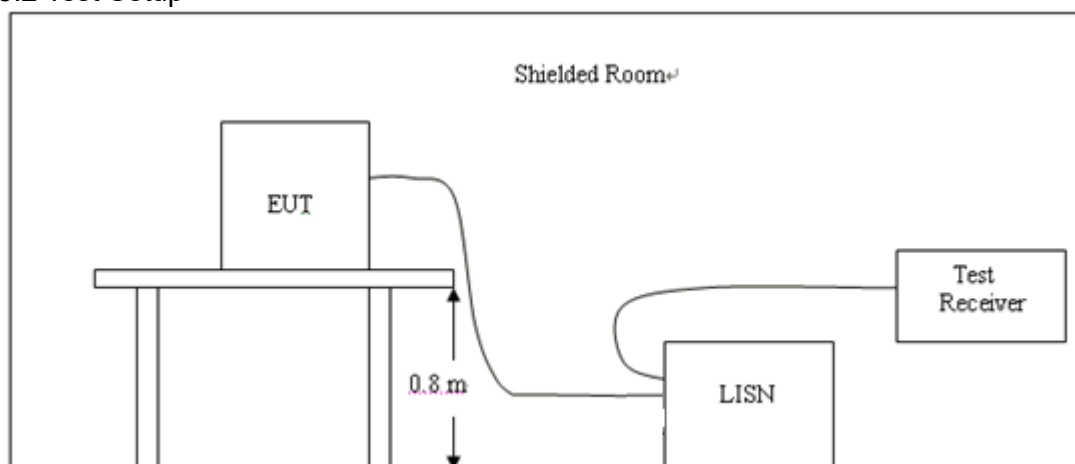

3.3 Test Procedure

- 1, The equipment was set up as per the test configuration to simulate typical actual usage per the user’s manual. The EUT is a tabletop system, a wooden table with a height of 0.8 meters is used and is placed on the ground plane as per ANSI C63.10.
- 2, Support equipment, if needed, was placed as per ANSI C63.10.
- 3, All I/O cables were positioned to simulate typical actual usage as per ANSI C63.10.
- 4, If a EUT received DC power from the USB Port of Notebook PC, the PC’s adapter received AC120V/60Hz power through a Line Impedance Stabilization Network (LISN) which supplied power source and was grounded to the ground plane.
- 5, All support equipments received AC power from a second LISN, if any.
- 6, The EUT test program was started. Emissions were measured on each current carrying line of the EUT using a spectrum Analyzer / Receiver connected to the LISN powering the EUT. The LISN has two monitoring points: Line 1 (Hot Side) and Line 2 (Neutral Side). Two scans were taken: one with Line 1 connected to Analyzer / Receiver and Line 2 connected to a 50 ohm load; the second scan had Line 1 connected to a 50 ohm load and Line 2 connected to the Analyzer / Receiver.
- 7, Analyzer / Receiver scanned from 150 KHz to 30MHz for emissions in each of the test modes.

3.4 Test Result

PASS

All the test modes completed for test. The worst case of Conducted Emission is CH 2407; the test data of this mode was reported.

Test Specification: Neutral

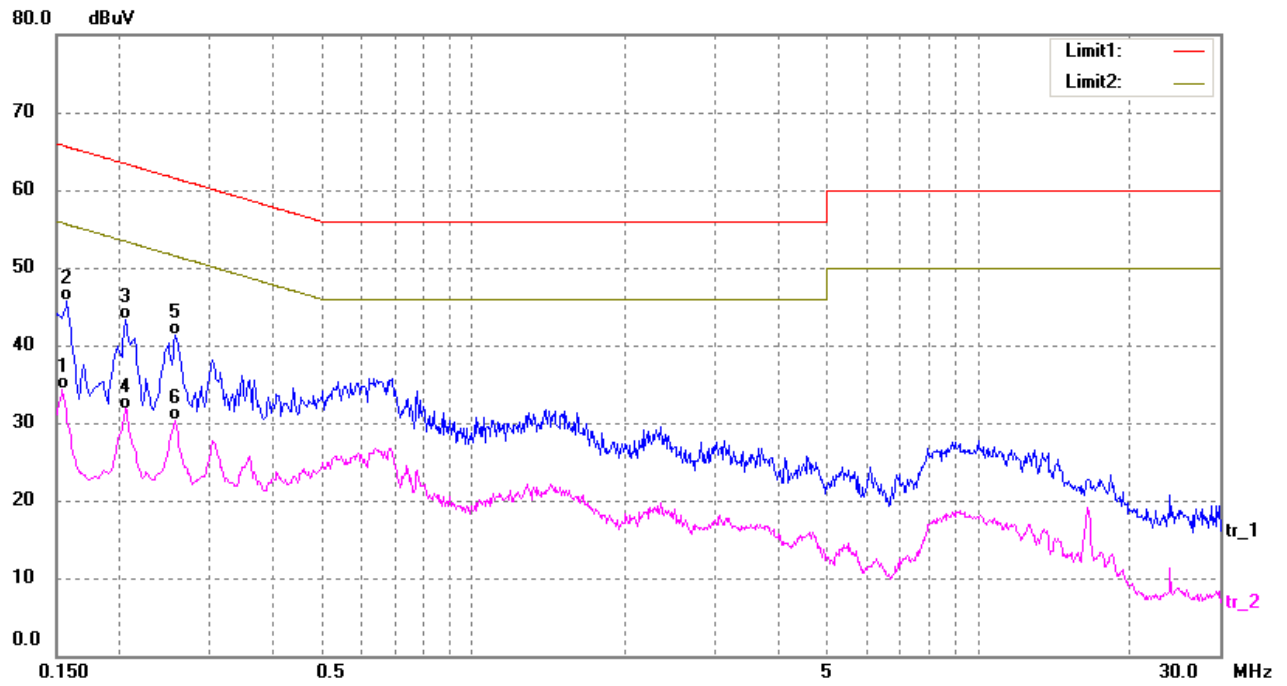

No.	Frequency (MHz)	Reading (dBuV)	Correct (dB/m)	Result (dBuV)	Limit (dBuV)	Margin (dB)	Detector
1	0.1539	24.53	9.85	34.38	55.78	-21.40	AVG
2*	0.1580	35.81	9.84	45.65	65.56	-19.91	QP
3	0.2060	33.50	9.80	43.30	63.36	-20.06	QP
4	0.2060	22.00	9.80	31.80	53.36	-21.56	AVG
5	0.2580	31.44	9.80	41.24	61.49	-20.25	QP
6	0.2580	20.50	9.80	30.30	51.49	-21.19	AVG

Test Specification: Line

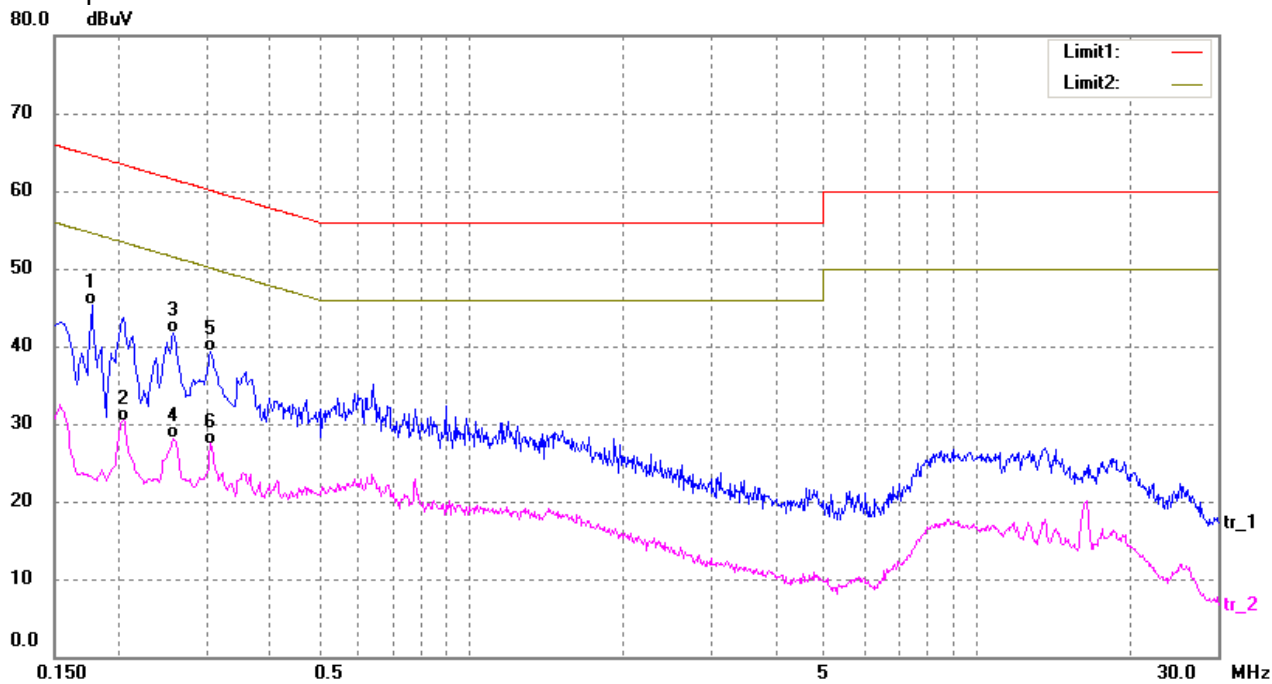

No.	Frequency (MHz)	Reading (dBuV)	Correct (dB/m)	Result (dBuV)	Limit (dBuV)	Margin (dB)	Detector
1*	0.1780	35.54	9.82	45.36	64.57	-19.21	QP
2	0.2060	20.60	9.80	30.40	53.36	-22.96	AVG
3	0.2580	31.98	9.80	41.78	61.49	-19.71	QP
4	0.2580	18.33	9.80	28.13	51.49	-23.36	AVG
5	0.3060	29.51	9.80	39.31	60.08	-20.77	QP
6	0.3060	17.60	9.80	27.40	50.08	-22.68	AVG

4 RADIATED EMISSION TEST

4.1 Radiation Limit

For unintentional device, according to § 15.109(a), except for Class A digital devices, the field strength of radiated emissions from unintentional radiators at a distance of 3 meters shall not exceed the following values:

Frequency (MHz)	Distance (Meters)	Radiated (dB μ V/m)	Radiated (μ V/m)
30-88	3	40	100
88-216	3	43.5	150
216-960	3	46	200
Above 960	3	54	500

For intentional device, according to § 15.209(a), the general requirement of field strength of radiated emissions from intentional radiators at a distance of 3 meters shall not exceed the above table.

4.2 Test Setup

(1) Radiated Emission Test-Up Frequency Below 30MHz

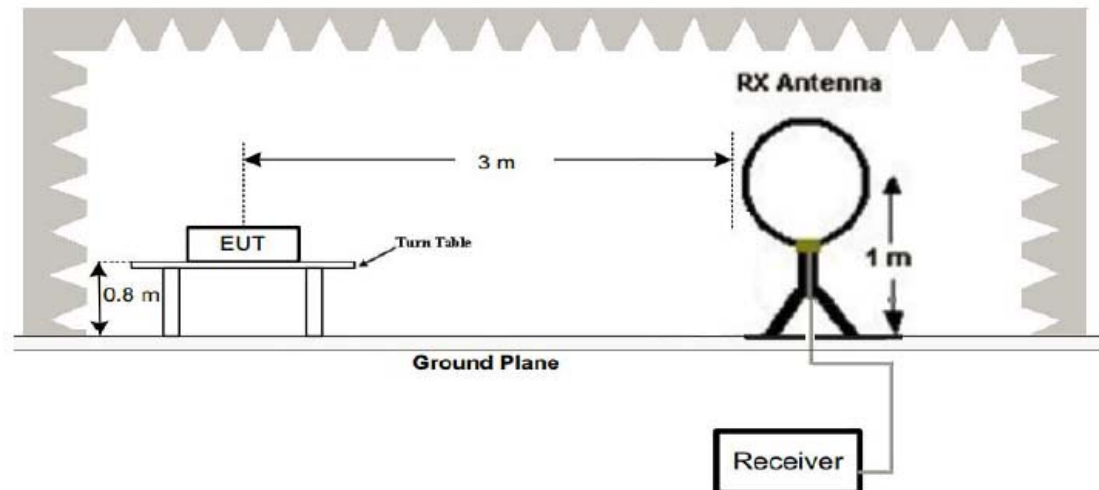

(2) Radiated Emission Test-Up Frequency 30MHz~1GHz

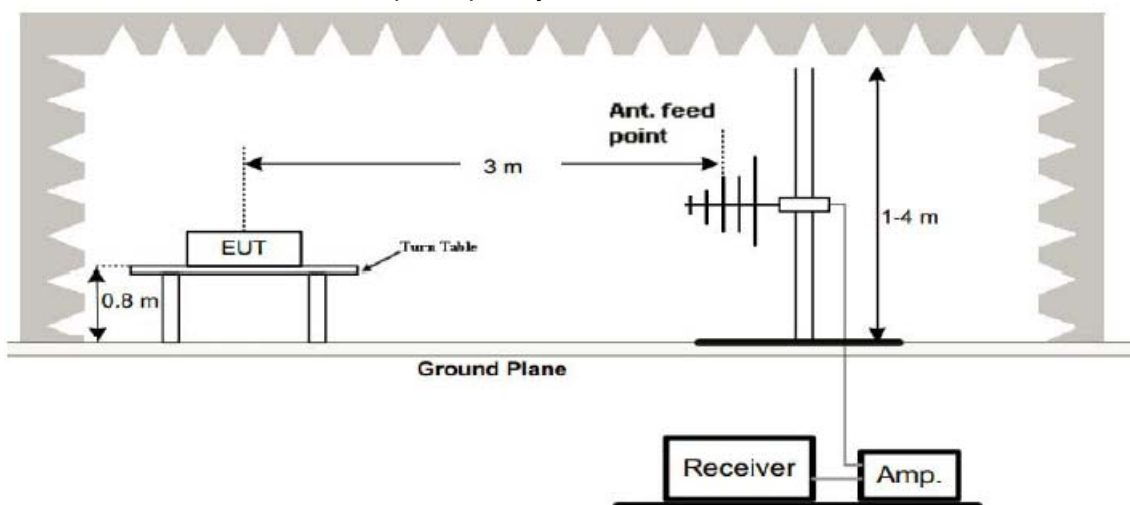

(3) Radiated Emission Test-Up Frequency Above 1GHz

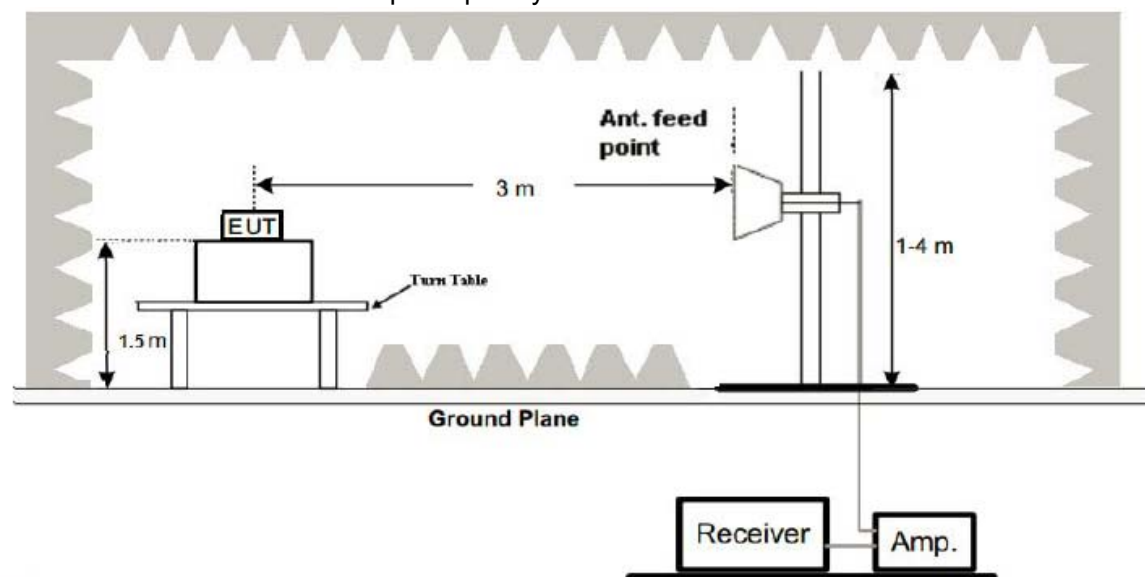

4.3 Test Procedure

1. Below 1GHz measurement the EUT is placed on turntable which is 0.8m above ground plane. And above 1GHz measurement EUT was placed on low permittivity and low tangent turn table which is 1.5m above ground plane.
2. The turntable shall be rotated for 360 degrees to determine the position of maximum emission level.
3. EUT is set 3m away from the receiving antenna, which is varied from 1m to 4m to find out the highest emissions.
4. Maximum procedure was performed on the six highest emissions to ensure EUT compliance.
5. And also, each emission was to be maximized by changing the polarization of receiving antenna both horizontal and vertical.
6. Repeat above procedures until the measurements for all frequencies are complete.
7. The test frequency range from 9KHz to 25GHz per FCC PART 15.33(a).

Note:

For battery operated equipment, the equipment tests shall be performed using a new battery.

4.4 Test Result

PASS

All the test modes completed for test. The worst case of Radiated Emission is CH 2407; the test data of this mode was reported.

Below 1GHz Test Results:
Antenna polarity: H

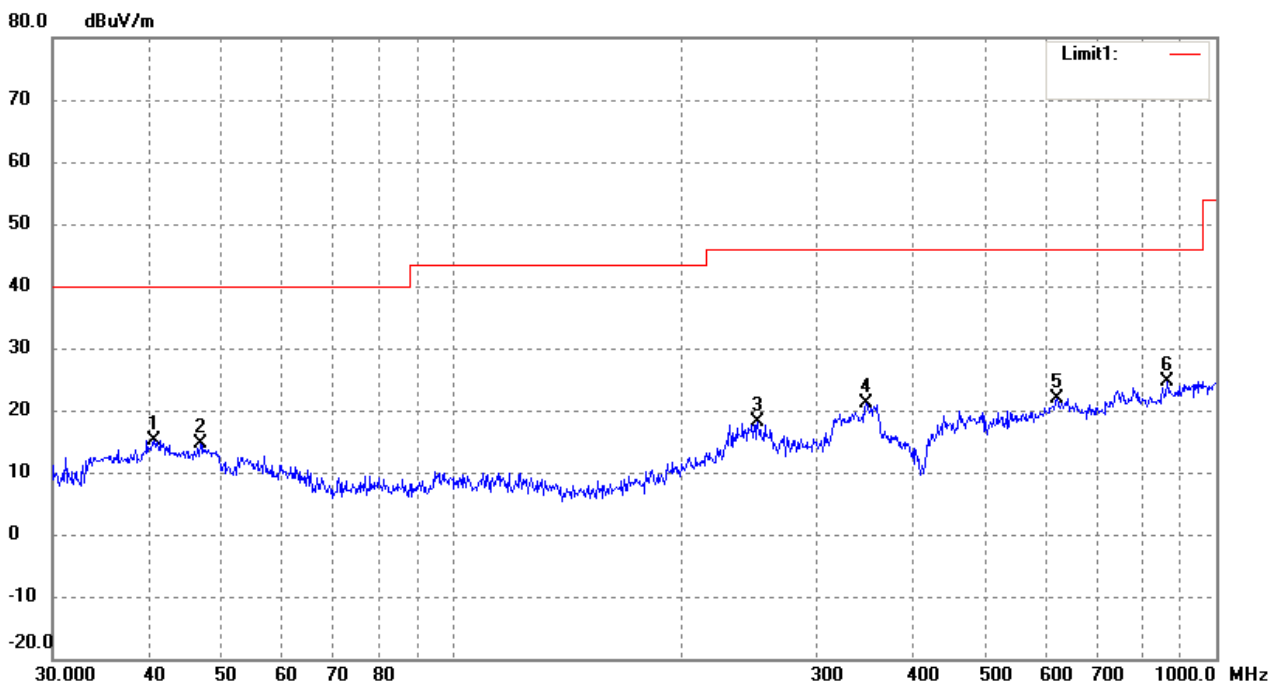

No.	Frequency (MHz)	Reading (dBuV/m)	Correct (dB/m)	Result (dBuV/m)	Limit (dBuV/m)	Margin (dB)	Degree ()	Height (cm)	Remark
1	40.7016	22.87	-7.71	15.16	40.00	-24.84	234	100	peak
2	46.8303	22.69	-8.11	14.58	40.00	-25.42	92	100	peak
3	251.1804	25.67	-7.55	18.12	46.00	-27.88	243	100	peak
4	348.0274	25.50	-4.29	21.21	46.00	-24.79	92	100	peak
5	618.5369	20.71	1.14	21.85	46.00	-24.15	177	100	peak
6	863.0562	21.63	2.97	24.60	46.00	-21.40	220	100	peak

Antenna polarity: V

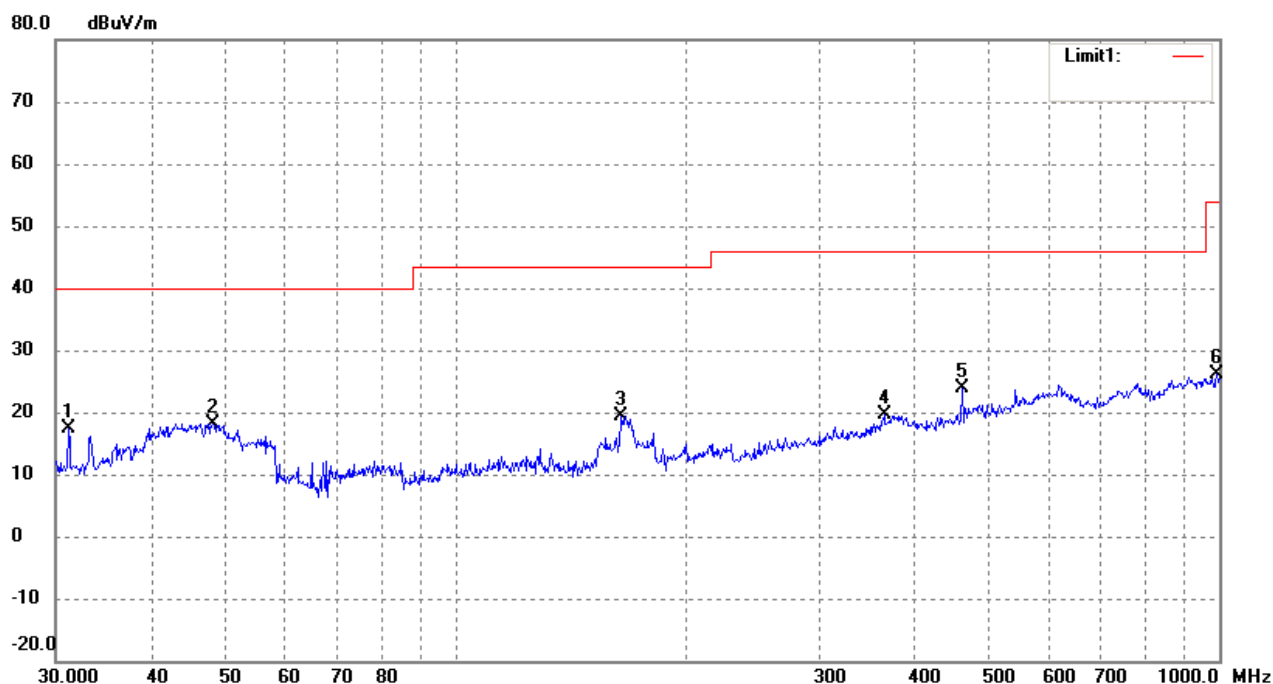

No.	Frequency (MHz)	Reading (dBuV/m)	Correct dB/m	Result (dBuV/m)	Limit (dBuV/m)	Margin (dB)	Degree ()	Height (cm)	Remark
1	31.1798	27.34	-10.01	17.33	40.00	-22.67	252	100	peak
2	48.1626	26.30	-8.20	18.10	40.00	-21.90	94	100	peak
3	164.9075	31.47	-12.04	19.43	43.50	-24.07	298	100	peak
4	364.2595	22.54	-3.00	19.54	46.00	-26.46	100	100	peak
5	460.7271	26.62	-2.63	23.99	46.00	-22.01	106	100	peak
6	993.0114	21.73	4.49	26.22	54.00	-27.78	328	100	peak

Remark:

- (1) Measuring frequencies from 9 KHz to the 1 GHz, Radiated emission test from 9KHz to 30MHz was verified, and no any emission was found except system noise floor.
- (2) * denotes emission frequency which appearing within the Restricted Bands specified in provision of 15.205, then the general radiated emission limits in 15.209 apply.
- (3) The IF bandwidth of EMI Test Receiver between 30MHz to 1GHz was 120KHz, 1 MHz for measuring above 1 GHz, below 30MHz was 10KHz.

Above 1 GHz Test Results:

CH Low (2407MHz)

Horizontal:

Frequency	Meter Reading	Factor	Emission Level	Limits	Margin	Detector Type
(MHz)	(dB μ V)	(dB)	(dB μ V/m)	(dB μ V/m)	(dB)	
2407	113.34	-5.84	107.5	114	-6.5	peak
2407	84.23	-5.84	78.39	94	-15.61	AVG
4814	57.42	-3.64	53.78	74	-20.22	peak
4814	44.29	-3.64	40.65	54	-13.35	AVG
7221	53.17	-0.95	52.22	74	-21.78	peak
7221	41.23	-0.95	40.28	54	-13.72	AVG
---	---	---	---	---	---	---
---	---	---	---	---	---	---

Remark: Factor = Antenna Factor + Cable Loss – Pre-amplifier.

Vertical:

Frequency	Meter Reading	Factor	Emission Level	Limits	Margin	Detector Type
(MHz)	(dB μ V)	(dB)	(dB μ V/m)	(dB μ V/m)	(dB)	
2407	111.12	-5.84	105.28	114	-8.72	peak
2407	84.23	-5.84	78.39	94	-15.61	AVG
4814	55.34	-3.64	51.7	74	-22.3	peak
4814	44.39	-3.64	40.75	54	-13.25	AVG
7221	53.31	-0.95	52.36	74	-21.64	peak
7221	37.52	-0.95	36.57	54	-17.43	AVG
---	---	---	---	---	---	---
---	---	---	---	---	---	---

Remark: Factor = Antenna Factor + Cable Loss – Pre-amplifier.

CH Middle (2440MHz)

Horizontal:

Frequency	Meter Reading	Factor	Emission Level	Limits	Margin	Detector Type
(MHz)	(dB μ V)	(dB)	(dB μ V/m)	(dB μ V/m)	(dB)	
2440	109.21	-5.71	103.5	114	-10.5	peak
2440	83.41	-5.71	77.7	94	-16.3	AVG
4880	58.29	-3.51	54.78	74	-19.22	peak
4880	44.86	-3.51	41.35	54	-12.65	AVG
7320	53.23	-0.82	52.41	74	-21.59	peak
7320	38.29	-0.82	37.47	54	-16.53	AVG
---	---	---	---	---	---	---
---	---	---	---	---	---	---

Remark: Factor = Antenna Factor + Cable Loss – Pre-amplifier.

Vertical:

Frequency	Meter Reading	Factor	Emission Level	Limits	Margin	Detector Type
(MHz)	(dB μ V)	(dB)	(dB μ V/m)	(dB μ V/m)	(dB)	
2440	107.19	-5.71	101.48	114	-12.52	peak
2440	84.27	-5.71	78.56	94	-15.44	AVG
4880	54.39	-3.51	50.88	74	-23.12	peak
4880	44.28	-3.51	40.77	54	-13.23	AVG
7320	52.51	-0.82	51.69	74	-22.31	peak
7320	36.66	-0.82	35.84	54	-18.16	AVG
---	---	---	---	---	---	---
---	---	---	---	---	---	---

Remark: Factor = Antenna Factor + Cable Loss – Pre-amplifier.

CH High (2477MHz)

Horizontal:

Frequency	Meter Reading	Factor	Emission Level	Limits	Margin	Detector Type
(MHz)	(dBµV)	(dB)	(dBµV/m)	(dBµV/m)	(dB)	
2477	108.11	-5.65	102.46	114	-11.54	peak
2477	82.96	-5.65	77.31	94	-16.69	AVG
4954	56.29	-3.43	52.86	74	-21.14	peak
4954	44.34	-3.43	40.91	54	-13.09	AVG
7431	54.19	-0.75	53.44	74	-20.56	peak
7431	38.22	-0.75	37.47	54	-16.53	AVG
---	---	---	---	---	---	---
---	---	---	---	---	---	---

Remark: Factor = Antenna Factor + Cable Loss – Pre-amplifier.

Vertical:

Frequency	Meter Reading	Factor	Emission Level	Limits	Margin	Detector Type
(MHz)	(dBµV)	(dB)	(dBµV/m)	(dBµV/m)	(dB)	
2477	107.49	-5.65	101.84	114	-12.16	peak
2477	84.17	-5.65	78.52	94	-15.48	AVG
4954	53.19	-3.43	49.76	74	-24.24	peak
4954	42.46	-3.43	39.03	54	-14.97	AVG
7431	53.55	-0.75	52.8	74	-21.2	peak
7431	37.71	-0.75	36.96	54	-17.04	AVG
---	---	---	---	---	---	---
---	---	---	---	---	---	---

Remark: Factor = Antenna Factor + Cable Loss – Pre-amplifier.

Remark:

- (1) Measuring frequencies from 1 GHz to the 25 GHz.
- (2) “F” denotes fundamental frequency; “H” denotes spurious frequency. “E” denotes band edge frequency.
- (3) * denotes emission frequency which appearing within the Restricted Bands specified in provision of 15.205, then the general radiated emission limits in 15.209 apply.
- (4) Data of measurement within this frequency range shown “---” in the table above means the reading of emissions are attenuated more than 20dB below the permissible limits or the field strength is too small to be measured.
- (5) The IF bandwidth of EMI Test Receiver between 30MHz to 1GHz was 120KHz, 1 MHz for measuring above 1 GHz, below 30MHz was 10KHz.
- (6) When the test results of Peak Detected below the limits of Average Detected, the Average Detected is not need completed. For example: Top Channel at Fundamental 73.16dBuV/m(PK Value) <93.98(AV Limit), at harmonic 53.20 dBuV/m(PK Value) <54 dBuV/m(AV Limit), the Average Detected not need to completed.

5 BAND EDGE

5.1 Limits

FCC PART 15.249(d) Emissions radiated outside of the specified frequency bands, except for harmonics, shall be attenuated by at least 50 dB below the level of the fundamental or to the general radiated emission limits in §15.209, whichever is the lesser attenuation.

5.2 Test Procedure

The band edge compliance of RF radiated emission should be measured by following the guidance in ANSI C63.10 with respect to maximizing the emission by rotating the EUT, measuring the emission while the EUT is situated in three orthogonal planes (if appropriate), adjusting the measurement antenna height and polarization etc. Set RBW to 100KHz and VBM to 300KHz to measure the peak field strength and set RBW to 1MHz and VBW to 10Hz to measure the average radiated field strength. The conducted RF band edge was measured by using a spectrum analyzer. Set span wide enough to capture the highest in-band emission and the emission at the band edge. Set RBW to 100 KHz and VBW to 300 KHz, to measure the conducted peak band edge.

5.3 Test Result

PASS

Lowest Bandedge

Vertical (Worst case)

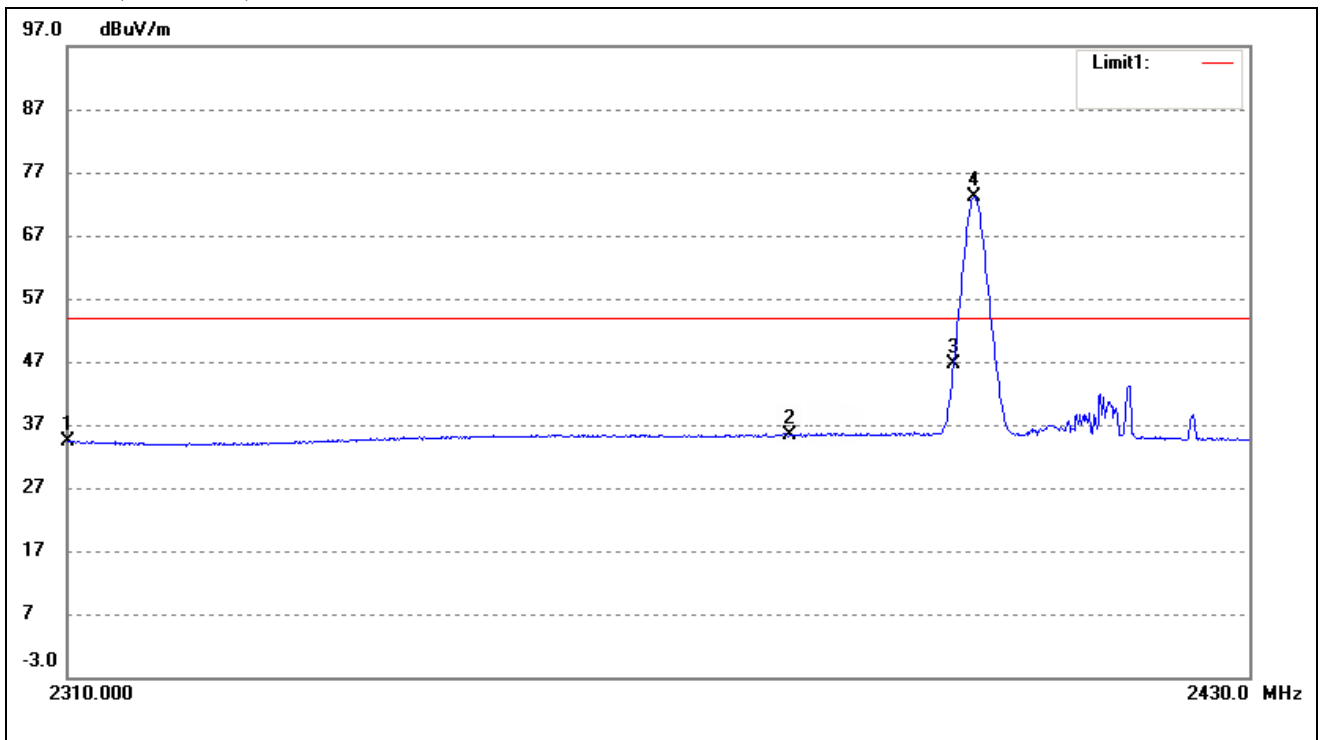

No.	Frequency (MHz)	Reading (dBuV/m)	Correct (dB/m)	Result (dBuV/m)	Limit (dBuV/m)	Margin (dB)	Remark
1	2310.00	35.41	-1.00	34.41	54.00	-19.59	Average Detector
	2310.00	48.89	-1.00	47.89	74.00	-26.11	Peak Detector
2	2390.00	36.28	-0.88	35.40	54.00	-18.60	Average Detector
	2390.00	48.00	-0.88	47.12	74.00	-26.88	Peak Detector
3	2405.00	47.56	-0.86	46.70	54.00	-7.30	Average Detector
	2405.00	52.22	-0.86	51.36	74.00	-22.64	Peak Detector
4	2407.04	74.02	-0.86	73.16	/	/	Average Detector
	2407.04	73.86	-0.86	73.00	/	/	Peak Detector

Highest Bandedge
Vertical (Worst case)

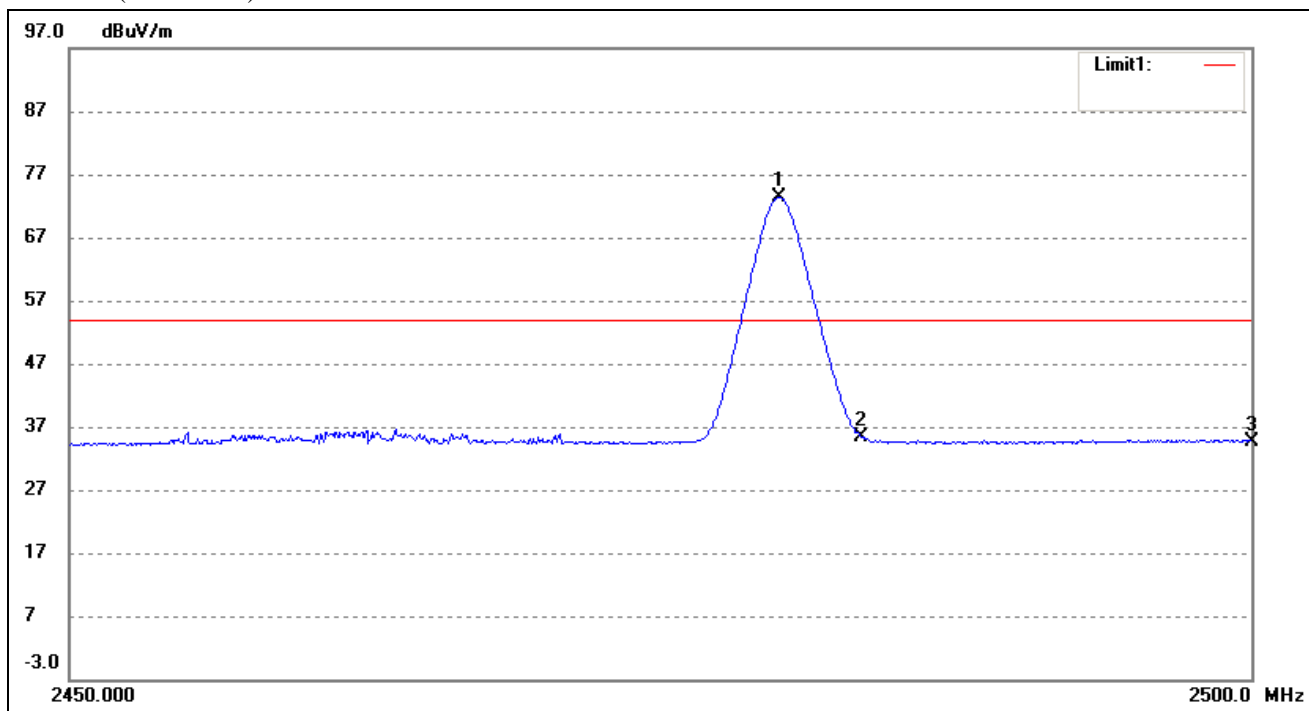

No.	Frequency (MHz)	Reading (dBuV/m)	Correct (dB/m)	Result (dBuV/m)	Limit (dBuV/m)	Margin (dB)	Remark
1	2477.00	74.05	-0.73	73.32	/	/	Average Detector
	2477.00	74.77	-0.73	74.04	/	/	Peak Detector
2	2483.50	36.16	-0.73	35.43	54.00	-18.57	Average Detector
	2483.50	47.81	-0.73	47.08	74.00	-26.92	Peak Detector
3	2500.00	35.42	-0.70	34.72	54.00	-19.28	Average Detector
	2500.00	48.14	-0.70	47.44	74.00	-26.56	Peak Detector

6 OCCUPIED BANDWIDTH MEASUREMENT

6.1 Test Setup

Same as Radiated Emission Measurement

6.2 Test Procedure

1. The EUT was placed on a turn table which is 0.8m above ground plane.
2. Set EUT as normal operation.
3. Based on FCC Part15 C Section 15.249(a): RBW= 30KHz. VBW= 100 KHz, Span=3MHz.
4. The useful radiated emission from the EUT was detected by the spectrum analyser with peak detector.

6.3 Measurement Equipment Used

Same as Radiated Emission Measurement

6.4 Test Result

PASS

Frequency	20dB Bandwidth (MHz)	99% Bandwidth (MHz)	Result
2407 MHz	1.154	1.097	PASS
2440MHz	1.164	1.107	PASS
2477 MHz	1.165	1.108	PASS

CH: 2407MHz

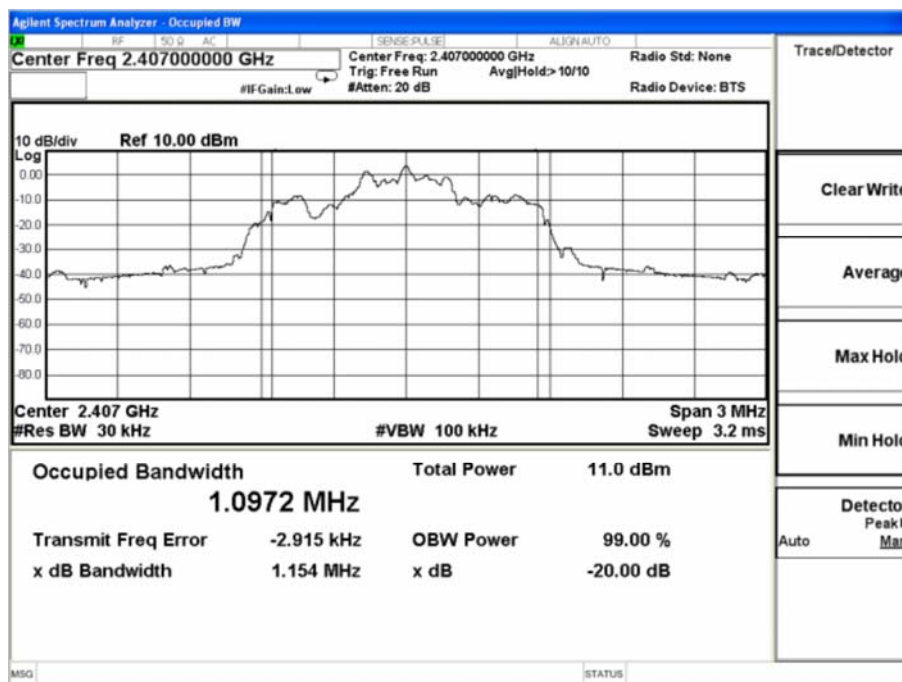

CH: 2440MHz

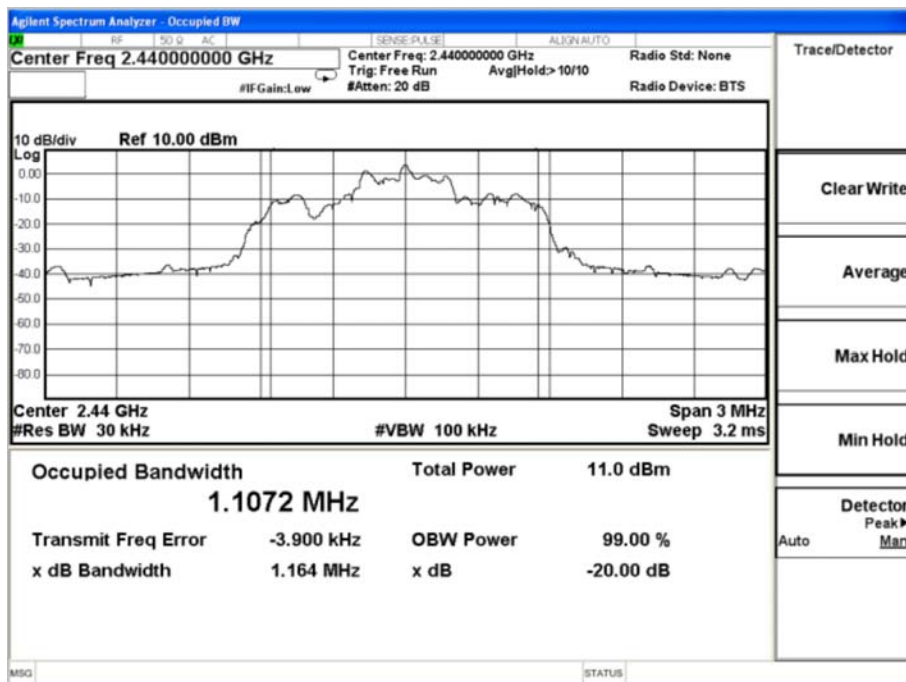

CH: 2477MHz

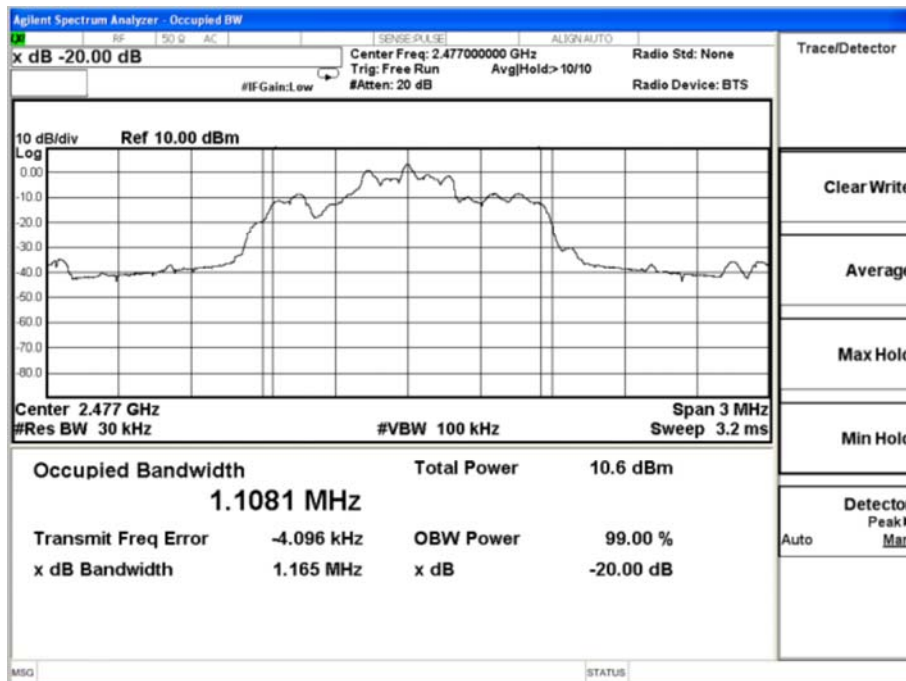

7 ANTENNA REQUIREMENT

Standard Applicable

For intentional device, according to FCC 47 CFR Section 15.203, an intentional radiator shall be designed to ensure that no antenna other than that furnished by the responsible party shall be used with the device. And according to FCC 47 CFR Section 15.249, if transmitting antennas of directional gain greater than 6dBi are used, the power shall be reduced by the amount in dB that the directional gain of the antenna exceeds 6dBi.

Refer to statement below for compliance.

The manufacturer may design the unit so that the user can replace a broken antenna, but the use of a standard antenna jack or electrical connector is prohibited. Further, this requirement does not apply to intentional radiators that must be professionally installed.

Antenna Connected Construction

The antenna used in this product is a PCB Antenna, The directional gains of antenna used for transmitting is 0dBi.

ANTENNA



8 PHOTOGRAPH OF TEST

8.1 Radiated Emission

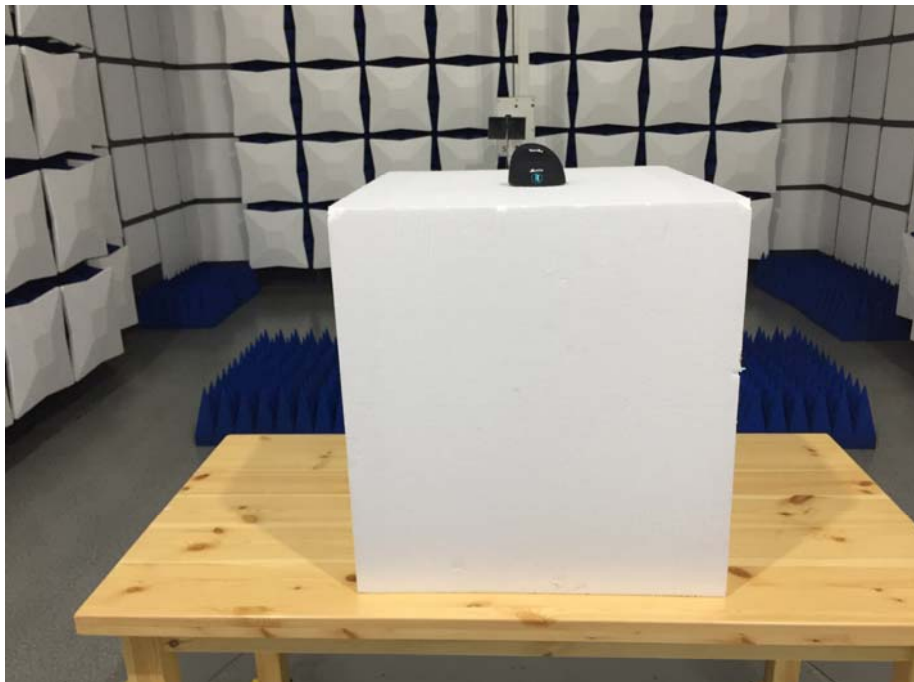
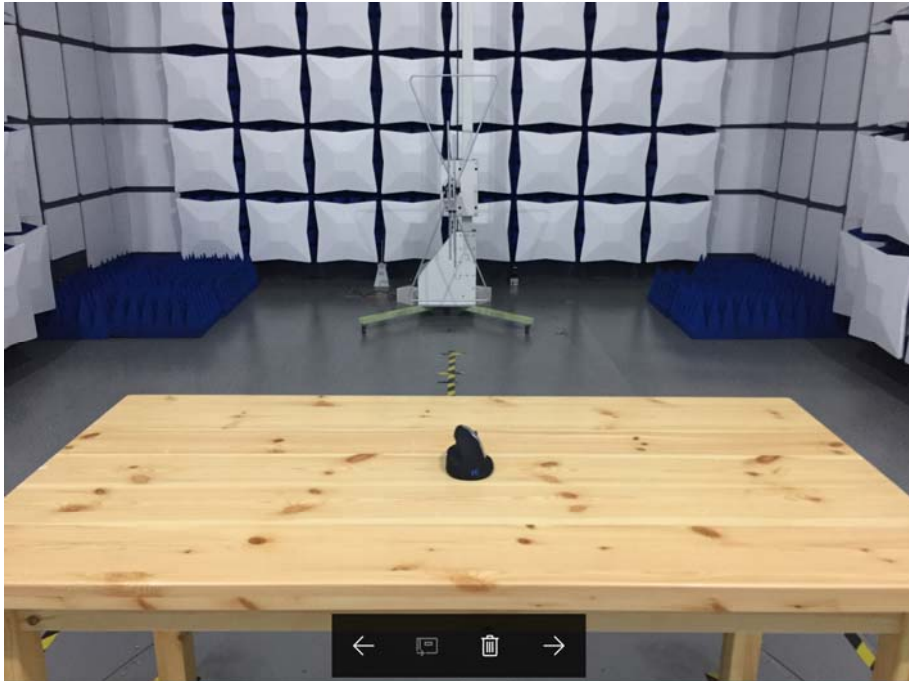

8.2 Conducted Emission

