



Report No.: 170116067GZU-002  
Issued: 2017-10-19

**TEST REPORT**

Applicant Name & Address : Carrier Corporation  
1025 Cobb Place Blvd., Kennesaw, GA 30152

Sample Description  
Product : Touch screen central controller  
FCC ID : 2AMPX-40VM900006  
Model No. : 40VM900006  
Electrical Rating : AC 24V, 24W

Date Received : 08 Sep., 2017  
Date Test Conducted : 10 Sep., 2017 – 17 Sep., 2017  
Test standards : 47 CFR PART 15 Subpart C: 2016 section 15.247

Test Result : Pass

Conclusion : The submitted samples complied with the above rules/standards.

Remark : TRF No.: FCC WIFI-b  
Effective date: 14 December 2016

\*\*\*\*\*End of Page\*\*\*\*\*

*Prepared and Checked By:*

*Approved By:*

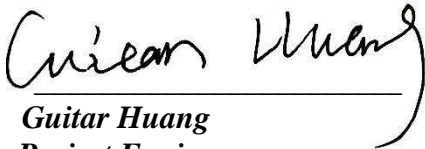
  
Guitar Huang  
Project Engineer  
Intertek Guangzhou

  
Helen Ma  
Team Leader  
Intertek Guangzhou  
19 Oct., 2017 Date

This report is for the exclusive use of Intertek's Client and is provided pursuant to the agreement between Intertek and its Client. Intertek's responsibility and liability are limited to the terms and conditions of the agreement. Intertek assumes no liability to any party, other than to the Client in accordance with the agreement, for any loss, expense or damage occasioned by the use of this report. Only the Client is authorized to permit copying or distribution of this report and then only in its entirety. Any use of the Intertek name or one of its marks for the sale or advertisement of the tested material, product or service must first be approved in writing by Intertek. The observations and test results in this report are relevant only to the sample tested. This report by itself does not imply that the material, product, or service is or has ever been under an Intertek certification program. The test report only allows to be revised within three years from its original issued date unless further standard or the requirement was noticed.

Intertek Testing Services Shenzhen Ltd. Guangzhou Branch  
Block E, No.7-2 Guang Dong Software Science Park, Caipin Road, Guangzhou Science City, GETDD Guangzhou, China  
Tel / Fax: 86-20-8213 9688/86-20-3205 7538  
© 2016 Intertek

FCC ID: 2AMPX-40VM900006  
TRF No.: FCC WIFI-b



**CONTENT**

**TEST REPORT** ..... 1

**CONTENT** ..... 2

1.0 Summary of Test..... 4

2.0 General Description ..... 5

    2.1 Product Description..... 5

    2.2 Related Submittal(s) Grants..... 6

    2.3 Test Methodology..... 6

    2.4 Test Facility..... 6

3.0 System Test Configuration..... 7

    3.1 Justification ..... 7

    3.2 EUT Exercising Software..... 8

    3.3 Special Accessories..... 8

    3.4 Measurement Uncertainty..... 8

    3.5 Equipment Modification..... 8

    3.6 Support Equipment List and Description..... 9

4.0 Measurement Results ..... 10

    4.1 Antenna Requirement: ..... 10

    4.2 6 dB Bandwidth (DTS bandwidth):..... 11

    4.3 Maximum Peak Conducted Output Power..... 20

    4.4 Peak Power Spectral Density..... 29

    4.5 Out of Band Conducted Emissions..... 38

    4.6 Out of Band Radiated Emissions..... 52

    4.7 Radiated Emissions in Restricted Bands..... 53

    4.8 Conducted Emission Test ..... 110

5.0 Test Equipment List

**Radiated Emission/Radio**

Equipment No.	Equipment	Model	Manufacturer	Cal. Due date (MM-DD-YYYY)	Calibration Interval
EM030-04	3m Semi-Anechoic Chamber	9×6×6 m <sup>3</sup>	ETS·LINDGRE N	2018/5/1	1Y
EM031-02	EMI Test Receiver (9 kHz~7 GHz)	R&S ESR7	R&S	2018/3/27	1Y
EM031-03	Signal and Spectrum Analyzer (10 Hz~40 GHz)	R&S FSV40	R&S	2018/5/18	1Y
EM011-04	Loop antenna (9 kHz-30 MHz)	HFH2-Z2	R&S	2018/6/14	1Y
EM061-03	TRILOG Super Broadband test Antenna (30 MHz-1.5 GHz) (TX)	VULB 9161	SCHWARZBECK	2018/6/7	1Y
EM033-01	TRILOG Super Broadband test Antenna(30 MHz-3 GHz) (RX)	VULB 9163	SCHWARZBECK	19/9/2018	1Y
EM033-02	Bouble-Ridged Waveguide Horn Antenna (800 MHz-18 GHz)(RX)	R&S HF907	R&S	2018/6/7	1Y
EM033-03	High Frequency Antenna & preamplifier(18 GHz~26.5 GHz) (RX)	R&S SCU-26	R&S	2018/5/4	1Y
EM033-04	High Frequency Antenna & preamplifier (26 GHz-40 GHz)	R&S SCU-40	R&S	2018/5/4	1Y
EM031-02-01	Coaxial cable(9 kHz-1 GHz)	N/A	R&S	2018/5/18	1Y
EM033-02-02	Coaxial cable(1 GHz-18 GHz)	N/A	R&S	2018/5/18	1Y
EM033-04-02	Coaxial cable(18 GHz~40 GHz)	N/A	R&S	2018/5/25	1Y
EM031-01	Signal Generator (9 kHz~6 GHz)	SMB100A	R&S	2018/8/1	1Y
EM085-02	Signal Generator (10MHz-40GHz)	68369B	Wiltron	2018/5/31	1Y
EM040-01	Band Reject/Notch Filter	WRHFV	Wainwright	N/A	1Y
EM040-02	Band Reject/Notch Filter	WRCGV	Wainwright	N/A	1Y
EM040-03	Band Reject/Notch Filter	WRCGV	Wainwright	N/A	1Y
EM022-03	2.45 GHz Filter	BRM50702	Micro-Tronics	2018/5/9	1Y
SA016-16	Programmable Temperature & Humidity Test Chamber	MHU-800LJ	TERCHY	2017/10/21	1Y
SA016-22	Climatic Test Chamber	C7-1500	Vötsch	2017/10/21	1Y
SA012-74	Digital Multimeter	FLUKE175	FLUKE	2017/10/13	1Y
EM010-01	Regulated DC Power supply	PAB-3003A	GUANHUA	N/A	1Y
SA040-22	Regulated DC Power supply	IT6721	ITECH	2018/9/14	1Y
EM084-06	Audio Analyzer	8903B	HP	2018/4/3	1Y
EM084-07	Modulation Analyzer	8901B	HP	2018/6/15	1Y
EM045-01-01	EMC32 software (RE/RS)	V10.01.00	R&S	N/A	N/A
EM045-01-09	EMC32 software (328/893)	V9.26.01	R&S	N/A	N/A

**Conducted emission at the mains terminals**

Equipment No.	Equipment	Model	Manufacturer	Cal. Due date (YYYY-MM-DD)	Calibration Interval
EM080-05	EMI receiver	ESCI	R&S	2018/7/24	1Y
EM006-05	LISN	ENV216	R&S	2018/6/4	1Y
EM006-06	LISN	ENV216	R&S	2018/9/14	1Y
EM006-06-01	Coaxial cable	/	R&S	2018/4/6	1Y
EM004-04	EMC shield Room	8m×3m×3m	Zhongyu	2018/1/23	1Y

..... 113

## 1.0 Summary of Test

TEST	TEST REQUIREMENT	TEST METHOD	RESULT
Antenna Requirement	FCC PART 15 C section 15.247 (c) and Section 15.203	FCC PART 15 C section 15.247 (c) and Section 15.203	PASS
6 dB Bandwidth (DTS bandwidth)	FCC PART 15 C section 15.247 (a)(2)	ANSI C63.10: Clause 11.8	PASS
Maximum Peak Conducted Output Power	FCC PART 15 C section 15.247(b)(3)	ANSI C63.10: Clause 11.9.1.2	PASS
Peak Power Spectral Density	FCC PART 15 C section 15.247(e)	ANSI C63.10: Clause 11.10.2	PASS
Out of Band Conducted Emissions	FCC PART 15 C section 15.209 &15.247(d)	ANSI C63.10: Clause 11.11	PASS
Out of Band Radiated Emission	FCC PART 15 C section 15.209 &15.247(d)	ANSI C63.10: Clause 11.11, 6.4, 6.5 and 6.6	N/A
Radiated Emissions in Restricted Bands	FCC PART 15 C section 15.209 &15.247(d)	ANSI C63.10: Clause 11.12.1, 6.4, 6.5 and 6.6	PASS
Band Edges Measurement	FCC PART 15 C section 15.247 (d) &15.205	ANSI C63.10: Clause 11.11 and 11.13	PASS
Conducted Emissions at Mains Terminals	FCC PART 15 C section 15.207	ANSI C63.10: Clause 6.2	PASS
<b>Remark:</b>			
<p>N/A: not applicable. Refer to the relative section for the details.            EUT: In this whole report EUT means Equipment Under Test.            Tx: In this whole report Tx (or tx) means Transmitter.            Rx: In this whole report Rx (or rx) means Receiver.            RF: In this whole report RF means Radio Frequency.            ANSI C63.10: the detail version is ANSI C63.10:2013 in the whole report.</p>			

## 2.0 General Description

### 2.1 Product Description

Operating Frequency	2412 MHz to 2462 MHz for 802.11b/g/n(HT20) 2422 MHz to 2452 MHz for 802.11n(HT40)
Type of Modulation:	802.11b: DSSS(CCK/QPSK/BPSK) 802.11g: OFDM(BPSK/QPSK/16QAM/64QAM) 802.11n: MIMO OFDM (BPSK/QPSK/16QAM/64QAM)
Transmit Data Rate:	802.11b :1/2/5.5/11 Mbps 802.11g :6/9/12/18/24/36/48/54 Mbps 802.11n(HT20): 6.5/13/19.5/26/39/52/58.5/65 Mbps/72.2Mbps 802.11n(HT40): 150Mbps
Number of Channels	11 Channels for 802.11b/g/n(HT20) 7 Channels for 802.11n(HT40)
Channel Separation:	5 MHz
Antenna Type	The wire antenna that uses a unique coupling to the intentional radiator
Antenna gain:	2 dBi
Function:	Touch screen central controller with 2.4 GHz WIFI
EUT Power Supply:	AC 24V, 24W
Power cord:	1.1 m x 2 wires unshielded AC supply cable

EUT channels and frequencies list:

For 802.11b/g/n(HT20): test frequencies are lowest channel 1: 2412 MHz, middle channel 6: 2437 MHz and highest channel 11: 2462 MHz.

For 802.11n(HT40): test frequencies are lowest channel 3: 2422 MHz, middle channel 6: 2437 MHz and highest channel 9: 2452 MHz

Channel	Frequency (MHz)	Channel	Frequency (MHz)
1	2412	7	2442
2	2417	8	2447
3	2422	9	2452
4	2427	10	2457
5	2432	11	2462
6	2437	/	/

## 2.2 Related Submittal(s) Grants

This is an application for certification of:

DTS- Part 15 Digital Transmission Systems (WIFI transmitter portion)

Remaining portions are subject to the following procedures:

1. Receiver portion of WIFI: exempt from technical requirement of this Part.

## 2.3 Test Methodology

Both AC mains line-conducted and radiated emission measurements were performed according to the procedures in ANSI C63.10:2013. Radiated emission measurement was performed in semi-anechoic chamber and conducted emission measurement was performed in shield room. For radiated emission measurement, preliminary scans and final tests were performed in the semi-anechoic chamber to determine the worst case modes. All radiated tests were performed at an antenna to EUT distance of 3 meters, unless stated otherwise.

## 2.4 Test Facility

All of the tests are performed at:

Intertek Testing Services Shenzhen Ltd. Guangzhou Branch. located at Block E, No.7-2 Guang Dong Software Science Park, Caipin Road, Guangzhou Science City, GETDD Guangzhou, 510663, China. This test facility and site measurement data have been fully placed on file with the A2LA, test Certificate Number is 0078.10.

FCC ID: 2AMPX-40VM900006

TRF No.: FCC WIFI-b

### 3.0 System Test Configuration

#### 3.1 Justification

For emissions testing, the equipment under test (EUT) setup to transmit continuously to simplify the measurement methodology. During testing, AC power line was manipulated to produce worst case emissions. It was powered by AC 120V/60Hz supply.

The signal is maximized through rotation and placement in the three orthogonal axes. The antenna height and polarization are varied during the search for maximum signal level. The antenna height is varied from 1 to 4 meters. Radiated emissions are taken at three meters unless the signal level is too low for measurement at that distance. If necessary, a pre-amplifier is used and/or the test is conducted at a closer distance.

All readings are extrapolated back to the equivalent three meter reading using inverse scaling with distance. Analyzer resolution is 100 kHz or greater for frequencies below 1000 MHz. The resolution is 1 MHz or greater for frequencies above 1000 MHz. The spurious emissions more than 20 dB below the permissible value are not reported.

For an intentional radiator, the spectrum shall be investigated from the lowest radio frequency signal generated in the device, without going below 9 kHz, up to at least the frequency shown in the following table:

Frequency range of radiated emission measurements

Lowest frequency generated in the device	Upper frequency range of measurement
9 kHz to below 10 GHz	10th harmonic of highest fundamental frequency or to 40 GHz, whichever is lower.
At or above 10 GHz to below 30 GHz	5th harmonic of highest fundamental frequency or to 100 GHz, whichever is lower.
At or above 30 GHz	5th harmonic of highest fundamental frequency or to 200 GHz, whichever is lower, unless otherwise specified.

Number of fundamental frequencies to be tested in EUT transmit band

Frequency range in which device operates	Number of frequencies	Location in frequency range of operation
1 MHz or less	1	Middle
1 MHz to 10 MHz	2	1 near top and 1 near bottom
More than 10 MHz	3	1 near top, 1 near middle and 1 near bottom

### 3.2 EUT Exercising Software

No special Software used.

### 3.3 Special Accessories

No special accessories used.

### 3.4 Measurement Uncertainty

No.	Item	Measurement Uncertainty
1	20 dB Bandwidth	2.3%
2	Carrier Frequencies Separated	2.3%
3	Maximum Peak Conducted Output Power	1.5
4	Out of Band Conducted Emissions	1.5
5	Radiated Emissions	4.7 dB (25 MHz-1 GHz)
		4.8 dB (1 GHz-18 GHz)
6	Conducted Emissions at Mains Terminals	2.58
7	Temperature	0.5 °C
8	Humidity	0.4 %
9	Time	1.2%

The measurement uncertainty describes the overall uncertainty of the given measured value during the operation of the EUT.

Measurement uncertainty is calculated in accordance with ETSI TR 100 028-2001.

The measurement uncertainty is given with a confidence of 95%, k=2.

When determining of the test conclusion, the Measurement Uncertainty of test has been considered.

Uncertainty and Compliance – Unless the standard specifically states that measured values are to be extended by the measurement uncertainty in determining compliance, all compliance determinations are based on the actual measured value.

### 3.5 Equipment Modification



Any modifications installed previous to testing by Carrier Corporation will be incorporated in each production model sold / leased in the United States.

No modifications were installed by Intertek Testing Services Shenzhen Ltd. Guangzhou Branch.

### 3.6 Support Equipment List and Description

This product was tested with corresponding support equipment as below:

#### Support Equipment

Description	Manufacturer	Model No.	SN/Version	Supplied by
Power Transformer	SHUNDE ZHANLIANG	TT2-F150- 1F(UL)	/	Applicant

#### Cable

Description	Model No.	Connector type	Cable length/type	Supplied by
Antenna cable	RF-01	SMA	0.2 m(shielded)	Intertek

#### 4.0 Measurement Results

##### 4.1 Antenna Requirement:

Standard requirement

15.203 requirement:

For intentional device. According to 15.203 an intentional radiator shall be designed to Ensure that no antenna other than that furnished by the responsible party shall be used with the device.

15.247(c) (1)(i) requirement:

(i) Systems operating in the 2400-2483.5 MHz bands that are used exclusively for fixed. Point-to-point operations may employ transmitting antennas with directional gain greater than 6 dBi provided the maximum conducted output power of the intentional radiator is reduced by 1 dB for every 3 dB that the directional gain of the antenna exceeds 6 dBi.

EUT Antenna

The antenna is an integral antenna and no consideration of replacement. The best case gain of the antenna is 2 dBi.

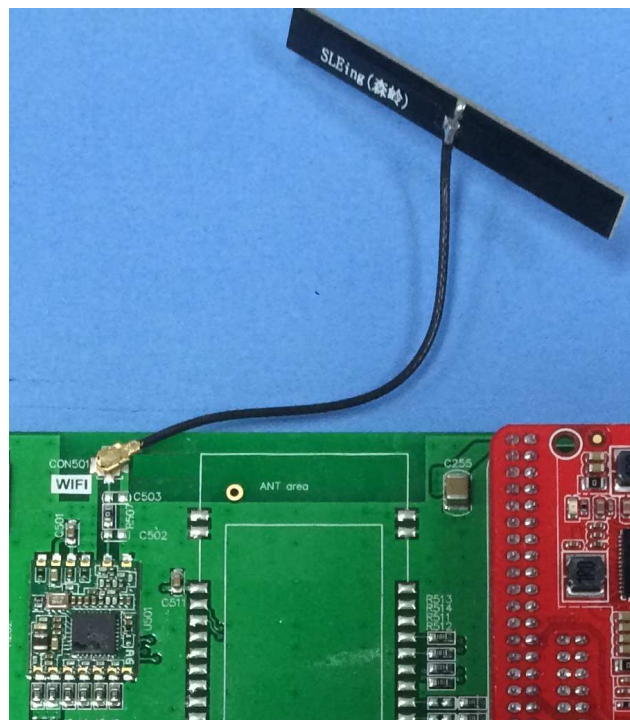

#### 4.2 6 dB Bandwidth (DTS bandwidth):

Test Requirement: FCC Part 15 C section 15.247  
(a)(2) Systems using digital modulation techniques may operate in the 902-928 MHz, 2400-2483.5MHz, and 5725-5850 MHz bands. The minimum 6 dB bandwidth shall be at least 500 kHz.

Test Method: ANSI C63.10: Clause 11.8

Test Status: Pre-Scan has been conducted to determine the worst-case mode from all possible combinations between available modulations, data rates and antenna ports (if EUT with antenna diversity architecture). Following channel(s) was (were) selected for the final test as listed below.

Test Configuration:

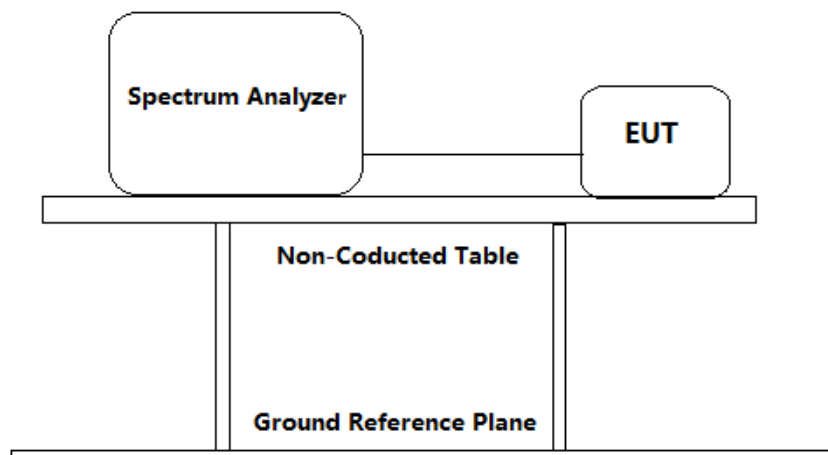

Test Procedure:

1. Remove the antenna from the EUT and then connect a low attention attenuation RF cable (cable loss =1dB) from the antenna port to the spectrum.
2. Set the spectrum analyzer:
  - a) Set RBW = 100 kHz
  - b) Set the VBW  $\geq [3 \times \text{RBW}]$
  - c) Detector = peak.
  - d) Trace mode = max hold.
  - e) Sweep = auto couple
  - f) Allow the trace to stabilize.
  - g) Measure the maximum width of the emission that is constrained by the frequencies associated with the two outermost amplitude points (upper and lower frequencies) that are



Report No.: 170116067GZU-002

Issued: 2017-10-19

attenuated by 6 dB relative to the maximum level measured in the fundamental emission.

h) Span=2\*BW~5\*BW

3. Repeat until all the test status is investigated.
4. Report the worst case.

### Used Test Equipment List

Spectrum Analyzer. Refer to Clause 5 Test Equipment List for details.

Channel No.	Frequency (MHz)	Mode	Data Rate	Measured 6dB bandwidth (MHz)	Limit	Result
1	2412	802.11b	11 Mbps	10.00	≥500KHz	Pass
6	2437		11 Mbps	10.00		Pass
11	2462		11 Mbps	10.07		Pass
1	2412	802.11g	54 Mbps	16.45		Pass
6	2437		54 Mbps	16.42		Pass
11	2462		54 Mbps	16.42		Pass
1	2412	802.11n (HT20)	72.2 Mbps	17.65		Pass
6	2437		72.2 Mbps	17.59		Pass
11	2462		72.2 Mbps	17.62		Pass
3	2422	802.11n (HT40)	150 Mbps	35.80		Pass
6	2437		150 Mbps	35.80		Pass
9	2452		150 Mbps	35.88		Pass

Test result: The unit does meet the FCC requirements.

Result plot as follows:

802.11b mode with 11Mbps data rate  
 Channel 1: 2.412GHz:

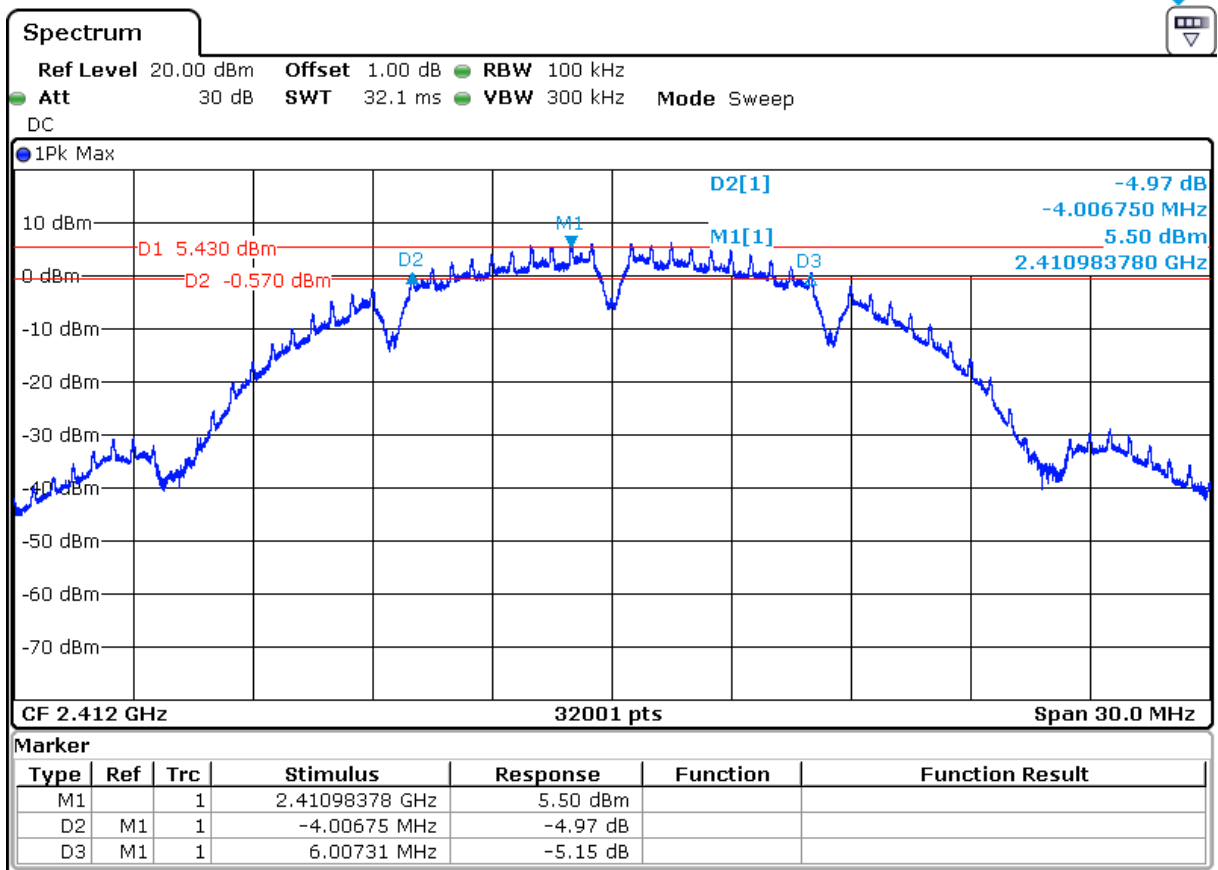

Channel 6: 2.437GHz:

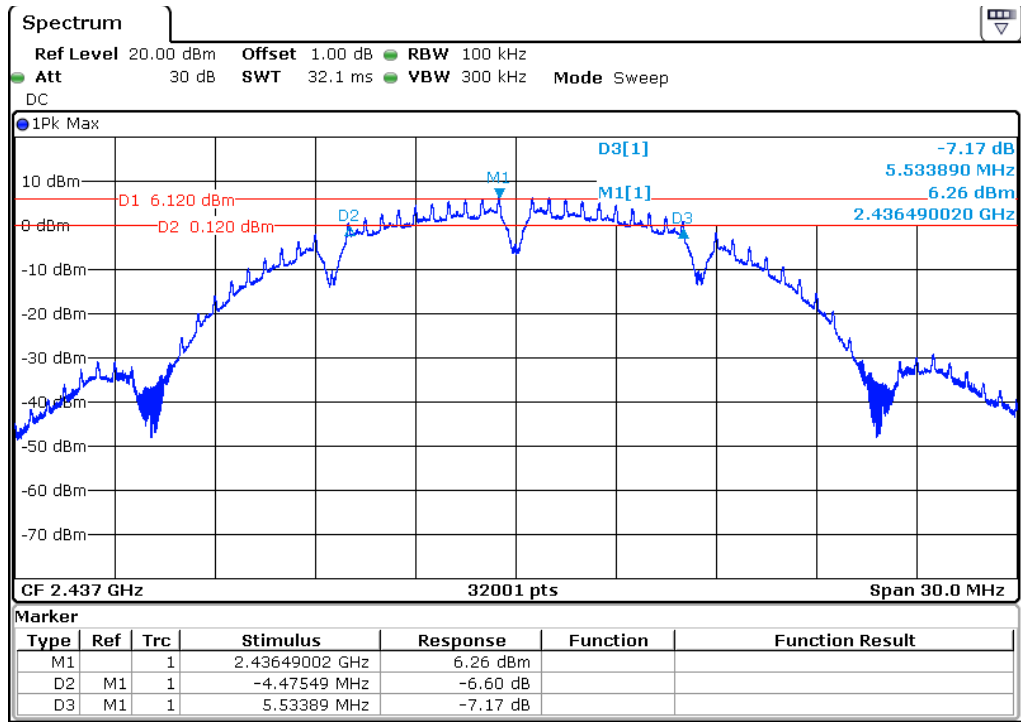

Channel 11: 2.462GHz:

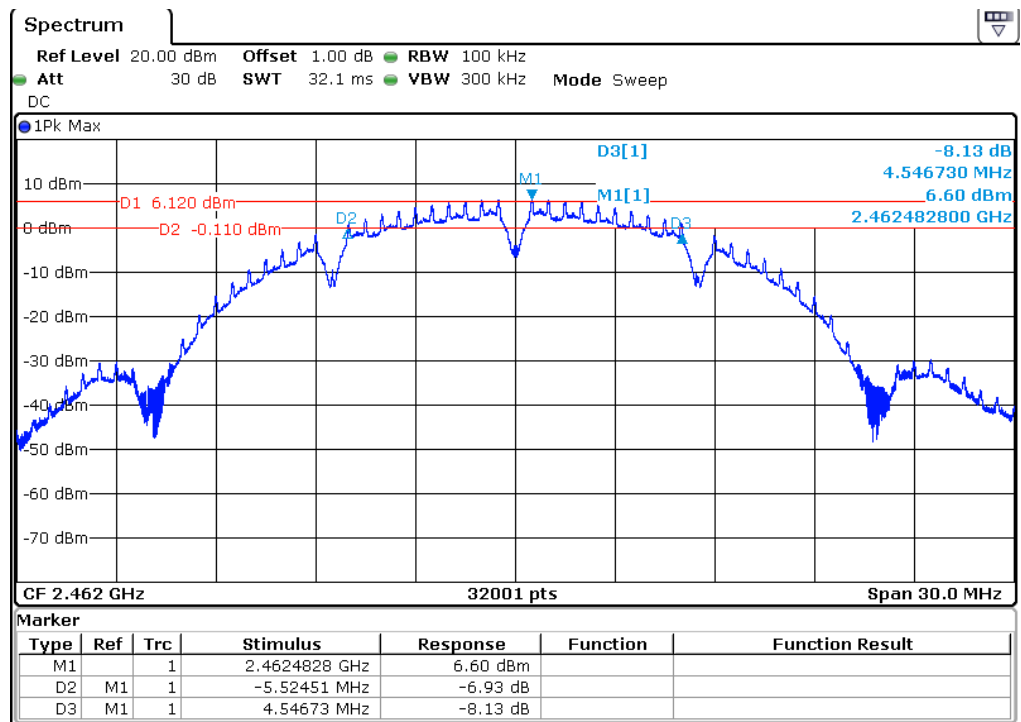

802.11g mode with 54Mbps data rate  
 Channel 1: 2.412GHz:

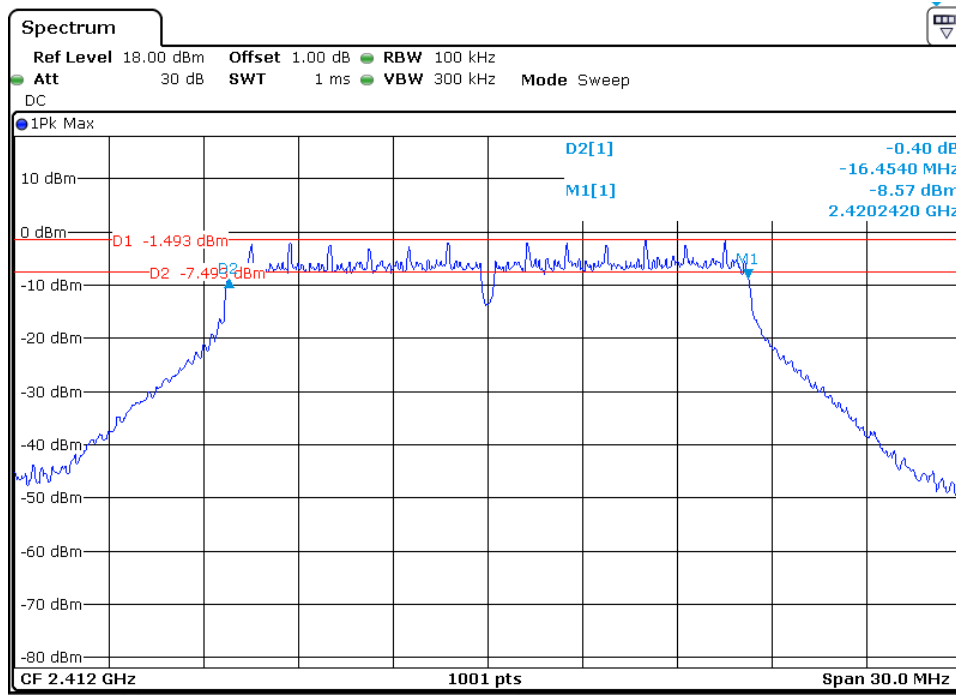

Channel 6: 2.437GHz:

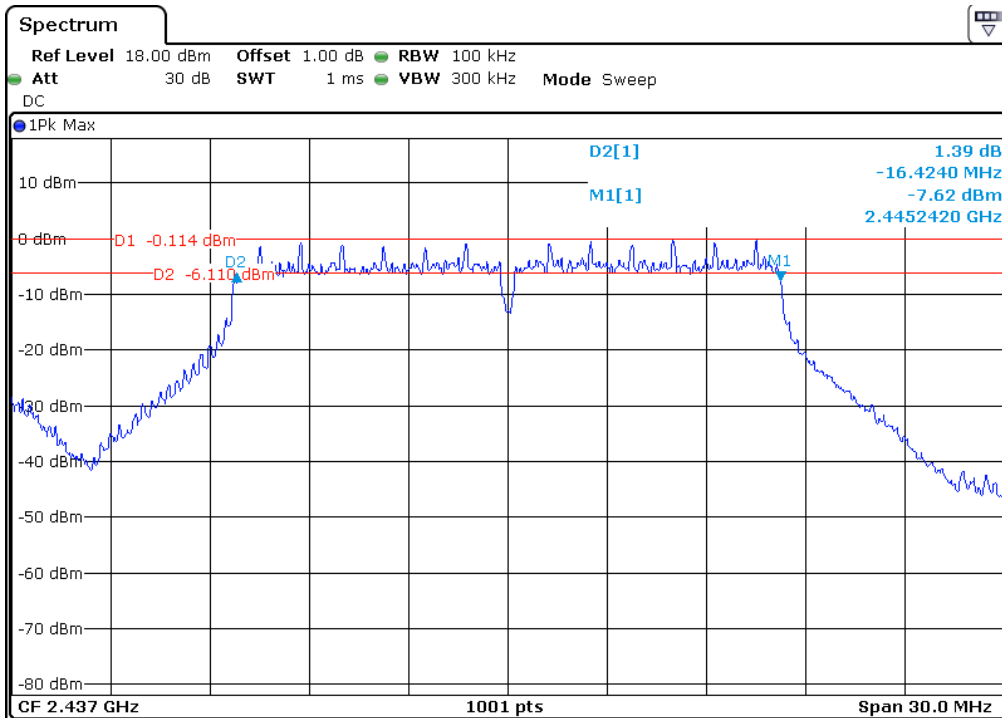

Channel 11: 2.462GHz:

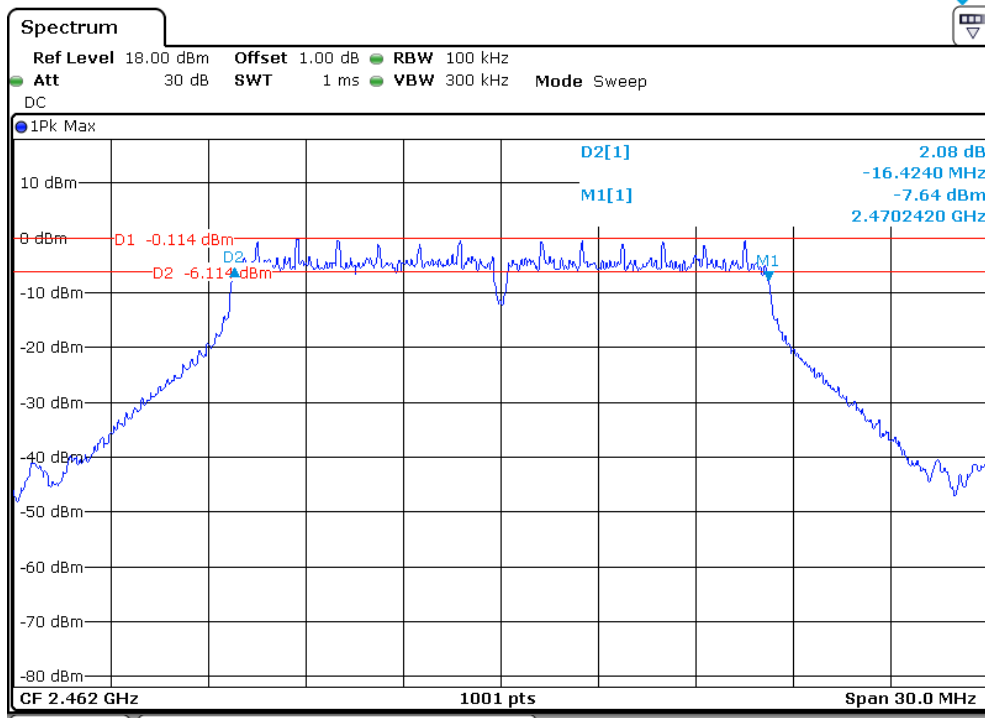

802.11n(HT20) mode with 72.2Mbps data rate  
 Channel 1: 2.412GHz:

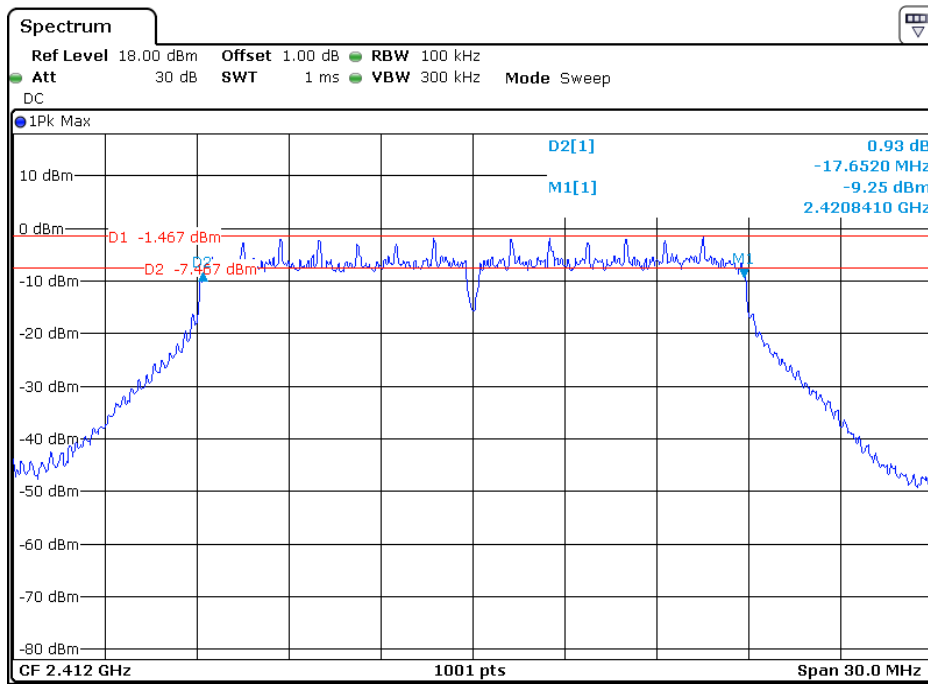



Channel 6: 2.437GHz:

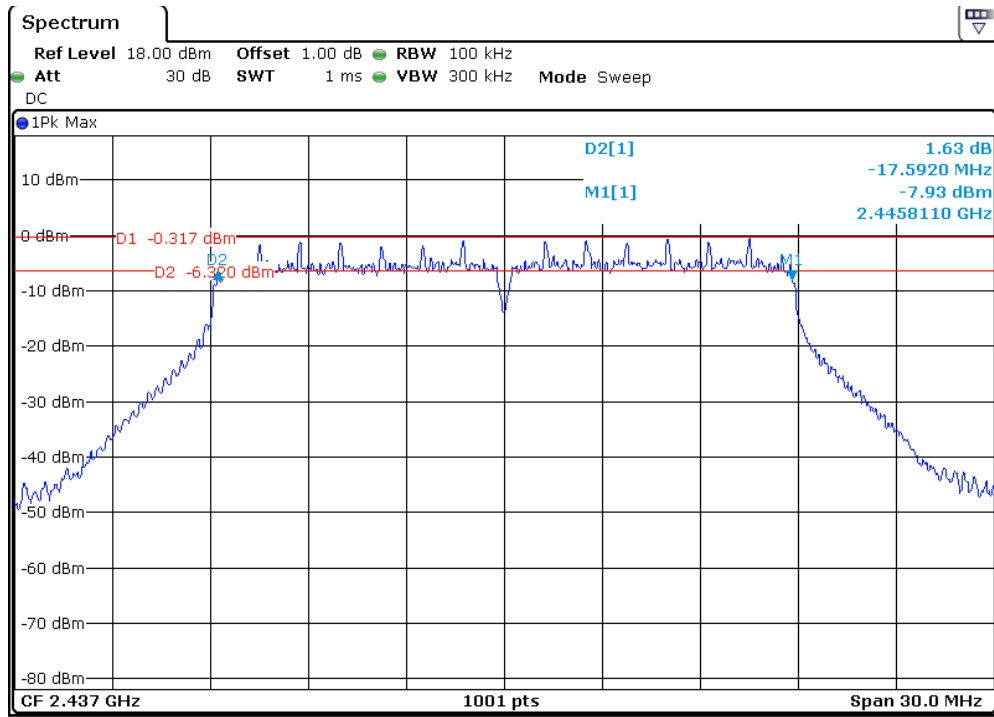

Channel 11: 2.462GHz:

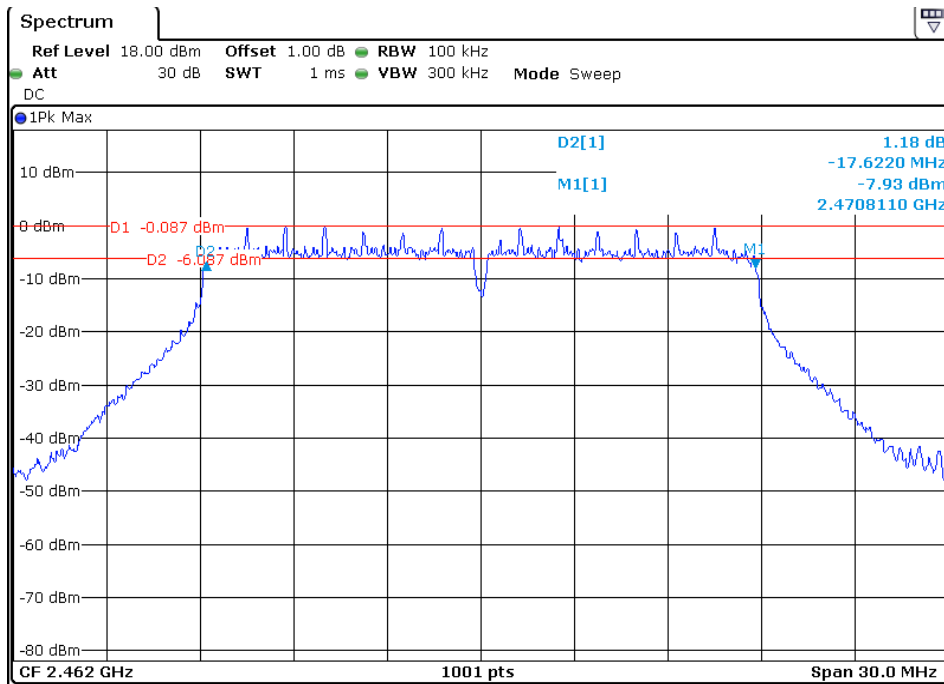

802.11n(HT40) mode with 150Mbps data rate

FCC ID: 2AMPX-40VM900006

TRF No.: FCC WIFI-b

Channel 3: 2.422GHz:

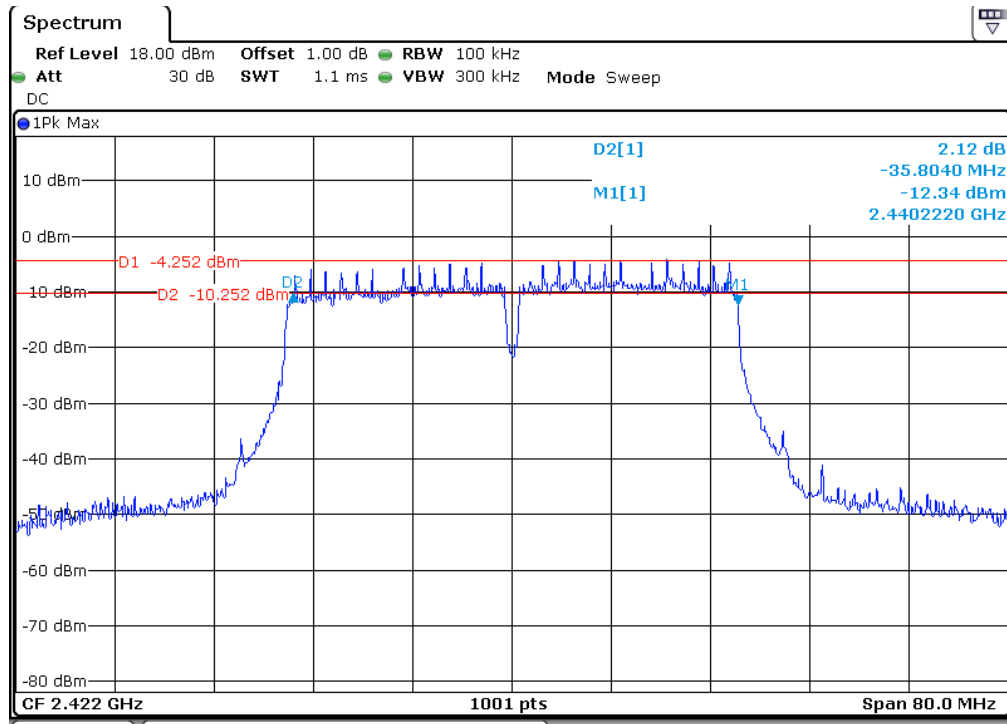

Channel 6: 2.437GHz:

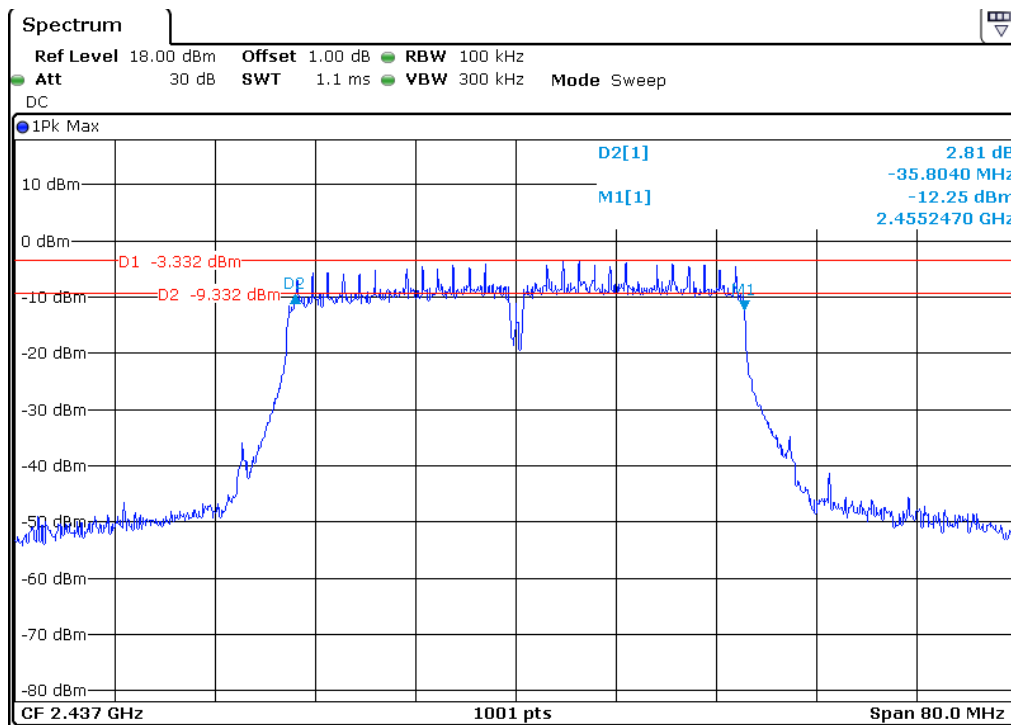



Report No.: 170116067GZU-002  
Issued: 2017-10-19

Channel 9: 2.452GHz:

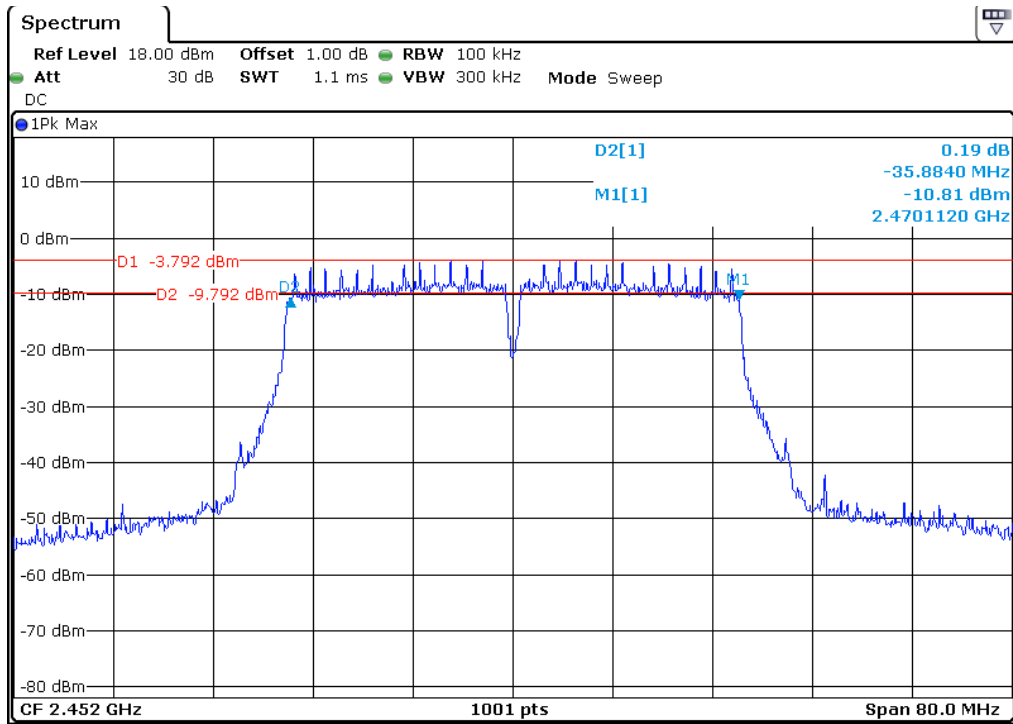

### 4.3 Maximum Peak Conducted Output Power

**Test Requirement:** FCC Part 15 C section 15.247  
(b)(3) For systems using digital modulation in the 902-928 MHz, 2400-2483.5 MHz, and 5725-5850 MHz bands: 1 Watt.  
Except as shown in paragraph (c) of this section, if transmitting antennas of directional gain greater than 6 dBi are used, the conducted output power from the intentional radiator shall be reduced below the stated values in paragraphs (b) (1), (b) (2), and (b) (3) of this section, as appropriate, by the amount in dB that the directional gain of the antenna exceeds 6 dBi.

**Test Method:** ANSI C63.10: Clause 11.9.1.2( Integrated band power method)

**Test Status:** Pre-Scan has been conducted to determine the worst-case mode from all possible combinations between available modulations, data rates and antenna ports (if EUT with antenna diversity architecture). Following channel(s) was (were) selected for the final test as listed below.

**Test Configuration:**

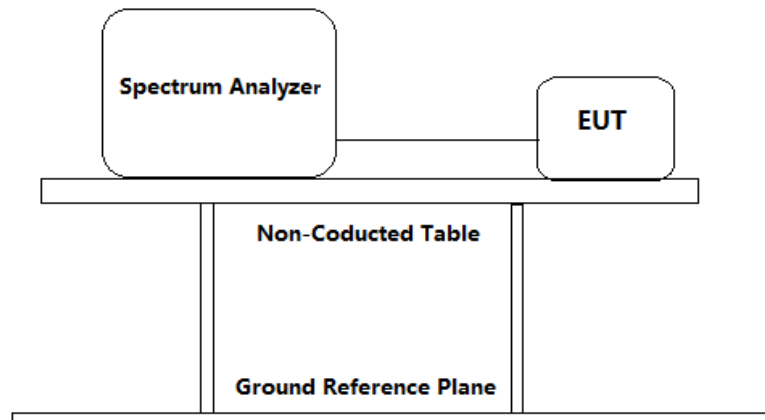

Test Procedure:

1. Remove the antenna from the EUT and then connect a low attention attenuation RF cable (cable loss =1dB) from the antenna port to the spectrum.
2. Set the spectrum analyzer:
  - a) Set the RBW = 1 MHz.
  - b) Set the VBW  $\geq [3 \times \text{RBW}]$ .
  - c) Set the span  $\geq [1.5 \times \text{DTS bandwidth}]$ .
  - d) Detector = peak.
  - e) Sweep time = auto couple.
  - f) Trace mode = max hold.
  - g) Allow trace to fully stabilize.
  - h) Use the instrument's band/channel power measurement function with the band limits set equal to the DTS bandwidth edges.
3. Repeat until all the test status is investigated.
4. Report the worst case.

**Used Test Equipment List**

Spectrum Analyzer. Refer to Clause 5 Test Equipment List for details.



Report No.: 170116067GZU-002  
 Issued: 2017-10-19

**Test result:**

Channel No.	Frequency (MHz)	Mode	Data Rate	Measured Channel Power (dBm)	Limit	Result
1	2412	802.11b	11 Mbps	18.61	1W (30dBm)	Pass
6	2437		11 Mbps	19.22		Pass
11	2462		11 Mbps	19.07		Pass
1	2412	802.11g	54 Mbps	18.50		Pass
6	2437		54 Mbps	19.20		Pass
11	2462		54 Mbps	19.47		Pass
1	2412	802.11n (HT20)	72.2 Mbps	18.61		Pass
6	2437		72.2 Mbps	19.18		Pass
11	2462		72.2 Mbps	19.35		Pass
3	2422	802.11n (HT40)	150 Mbps	18.12		Pass
6	2437		150 Mbps	18.25		Pass
9	2452		150 Mbps	18.09		Pass

Remark: Level = Read Level + Cable Loss (1 dB).  
 The unit does meet the FCC requirements.

Result plot as follows:

**802.11b mode with 11Mbps data rate**

Channel 1: 2.412GHz:

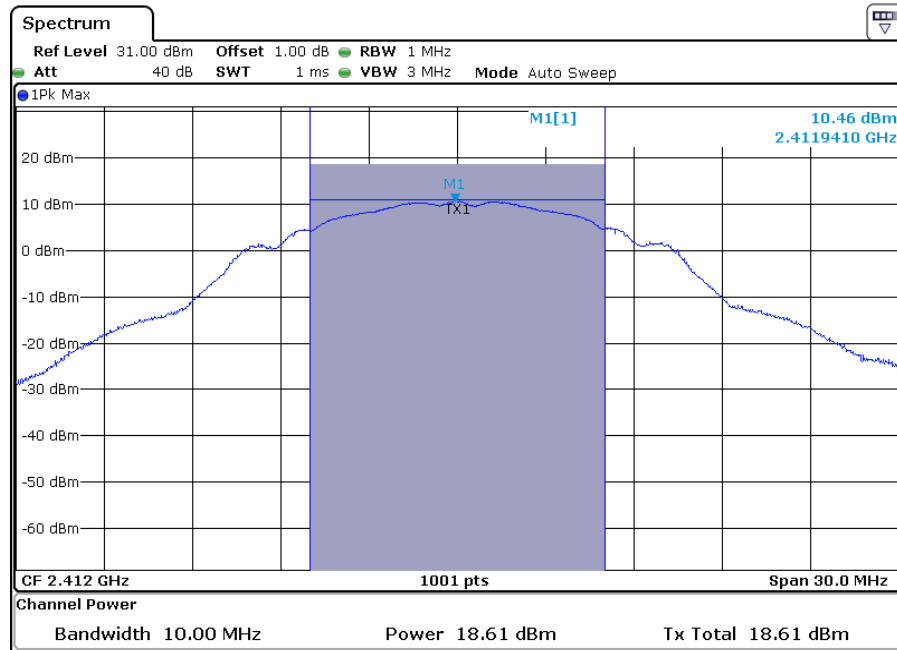

Channel 6: 2.437GHz:

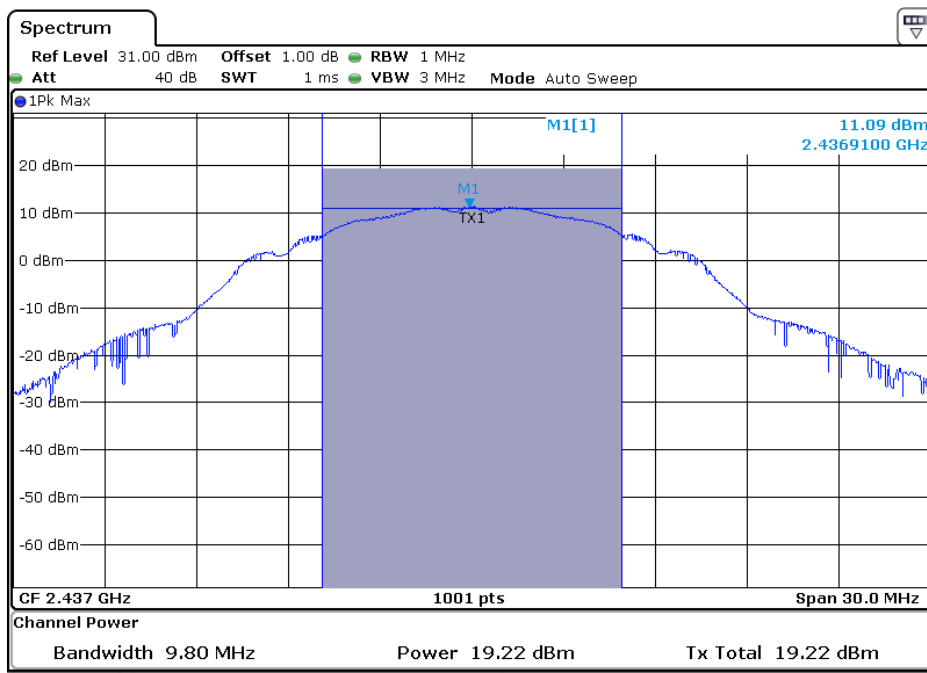

Channel 11: 2.462GHz:

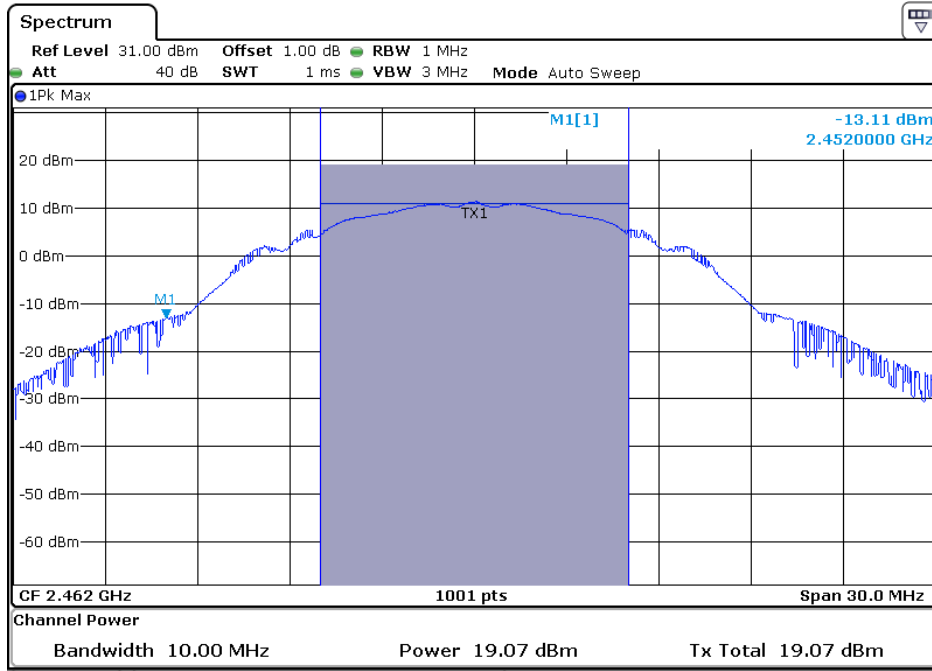

**802.11g mode with 54Mbps data rate**

Channel 1: 2.412GHz:

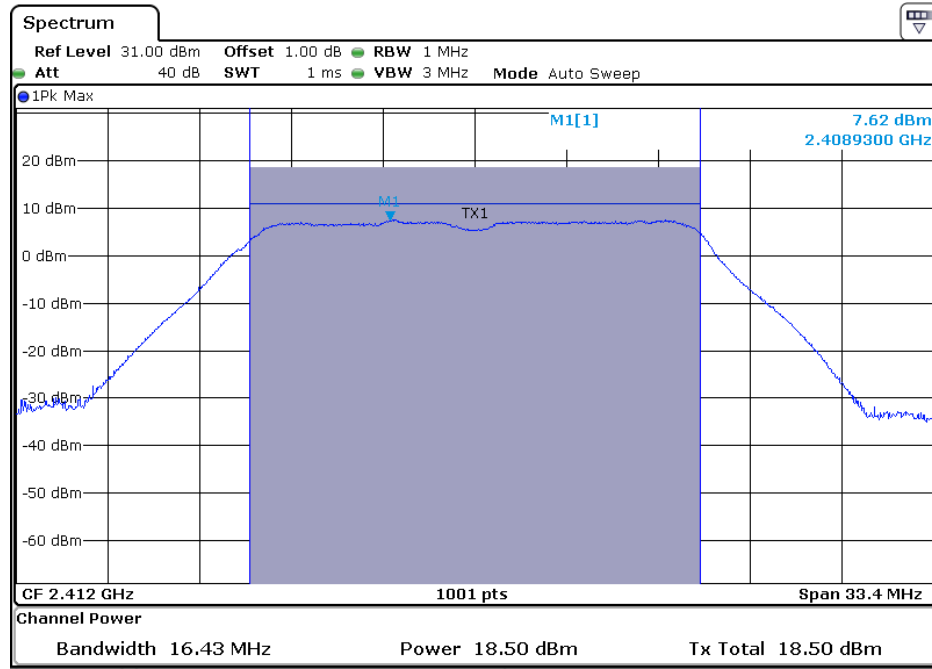



Channel 6: 2.437GHz:

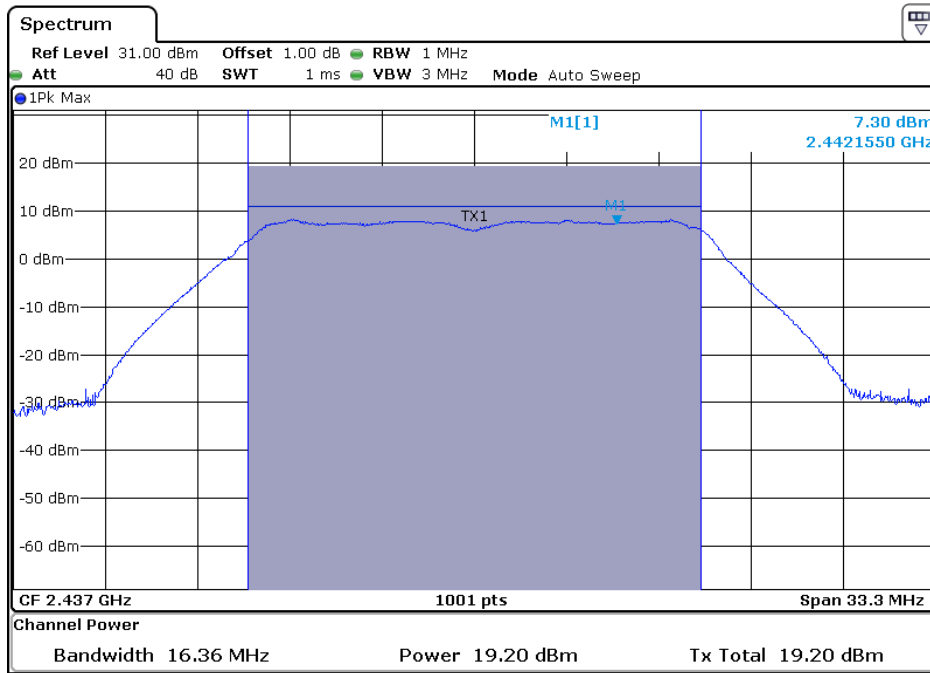

Channel 11: 2.462GHz:

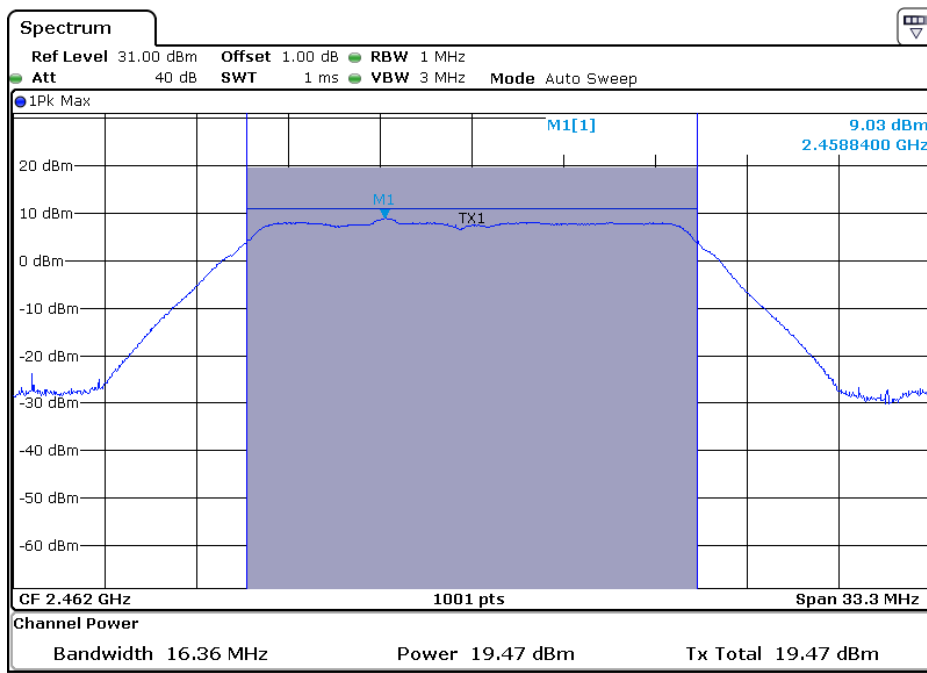

**802.11n(HT20) mode with 72.2Mbps data rate**  
 Channel 1: 2.412GHz:

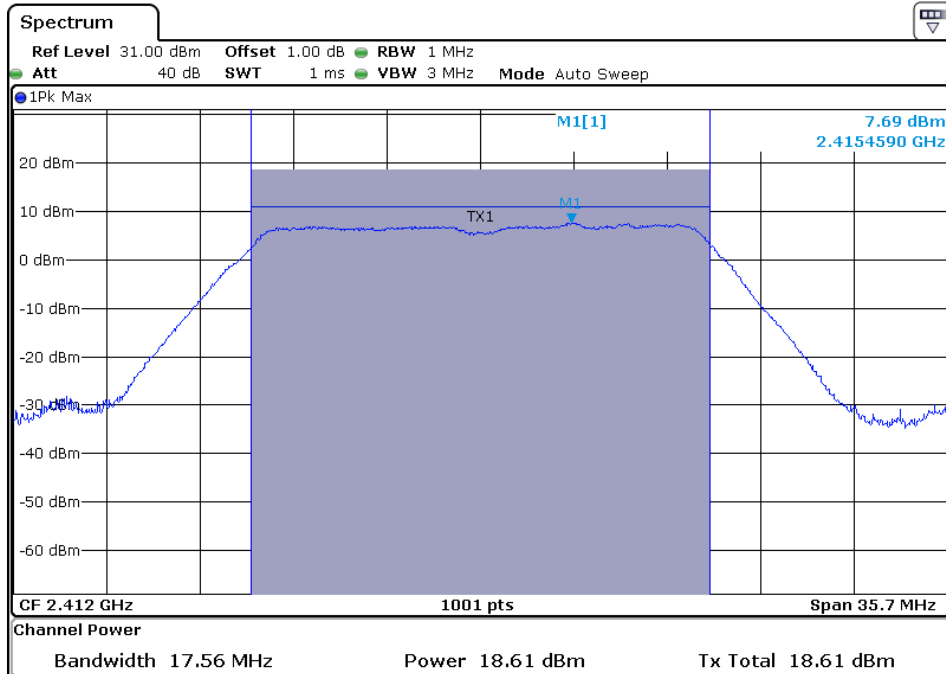

Channel 6: 2.437GHz:

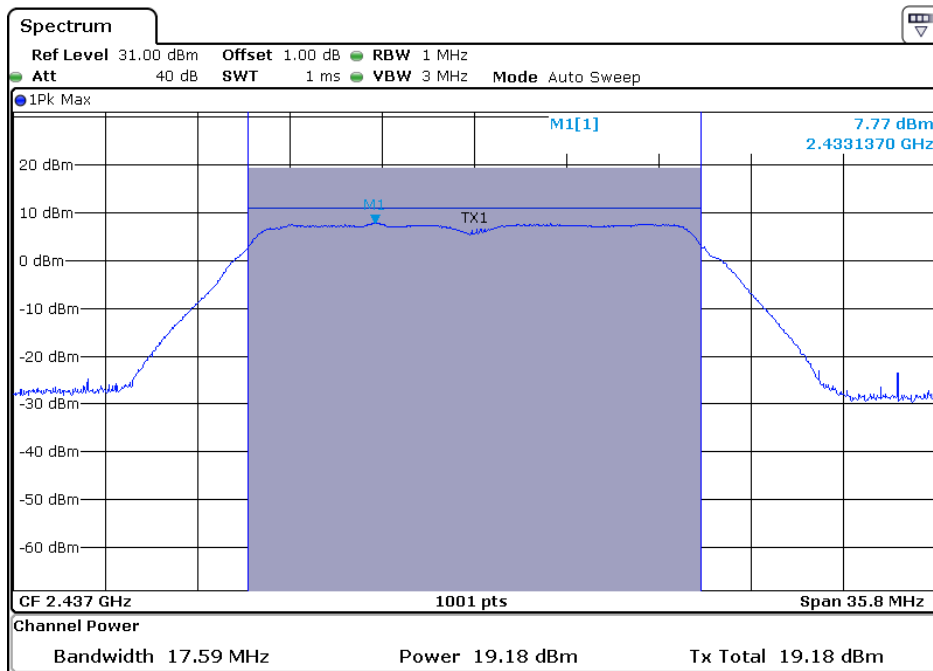

Channel 11: 2.462GHz:

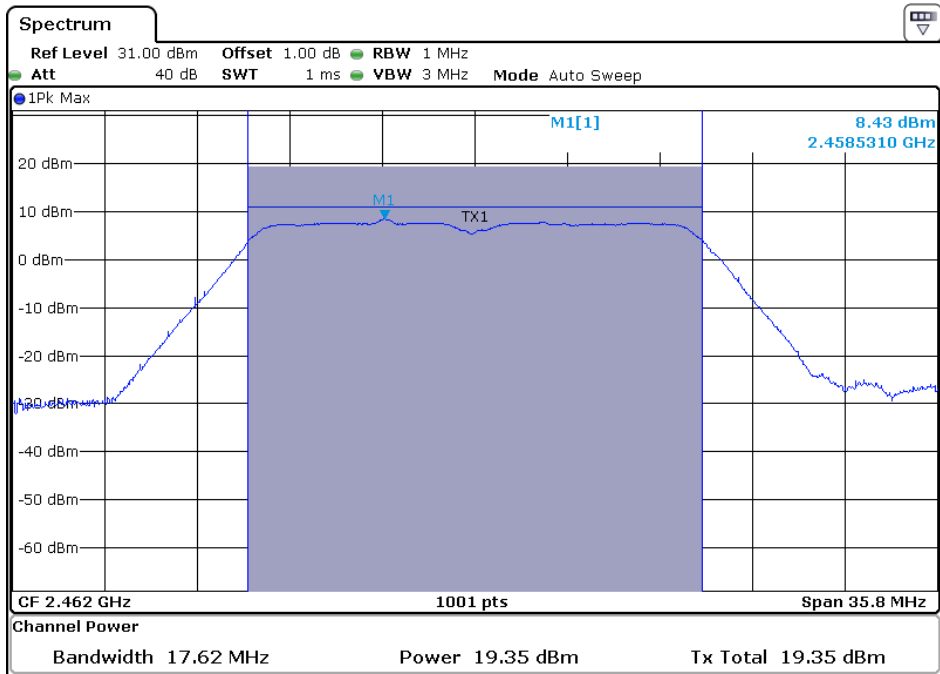

**802.11n(HT40) mode with 150Mbps data rate**

Channel 3: 2.422GHz:

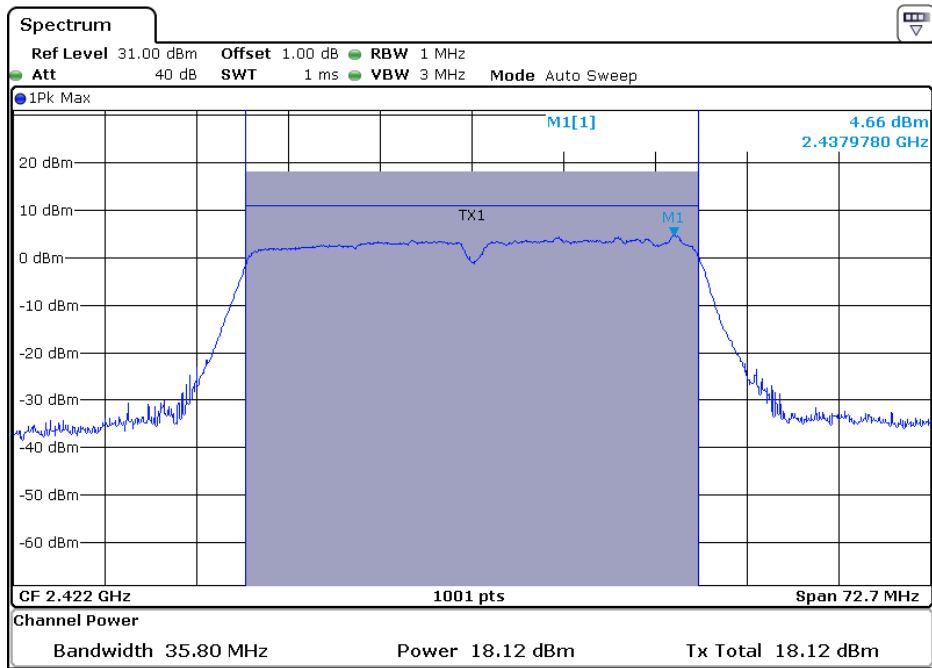

Channel 6: 2.437GHz:

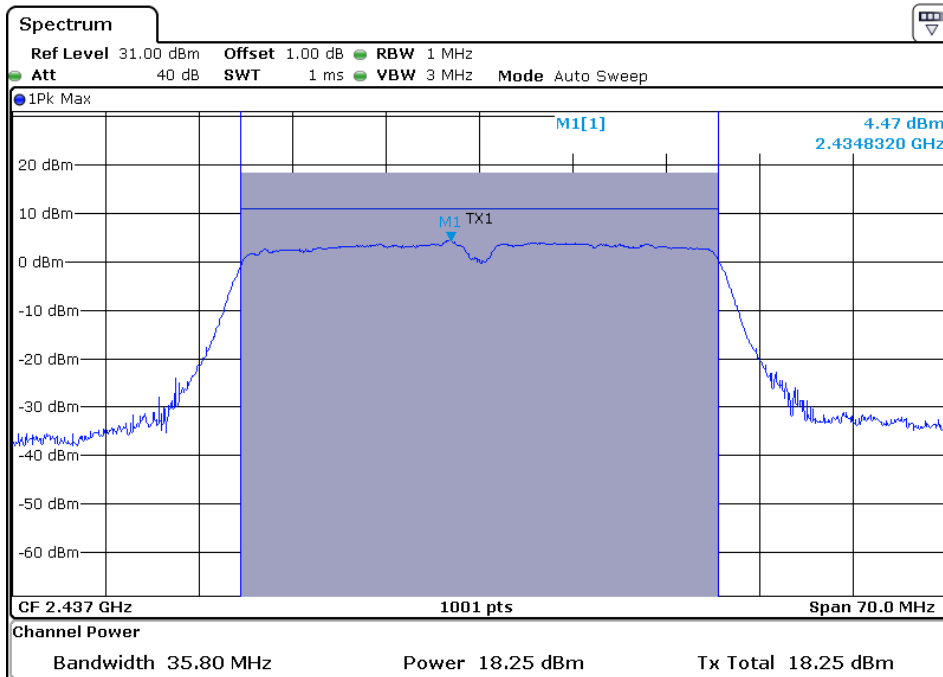

Channel 9: 2.452GHz:

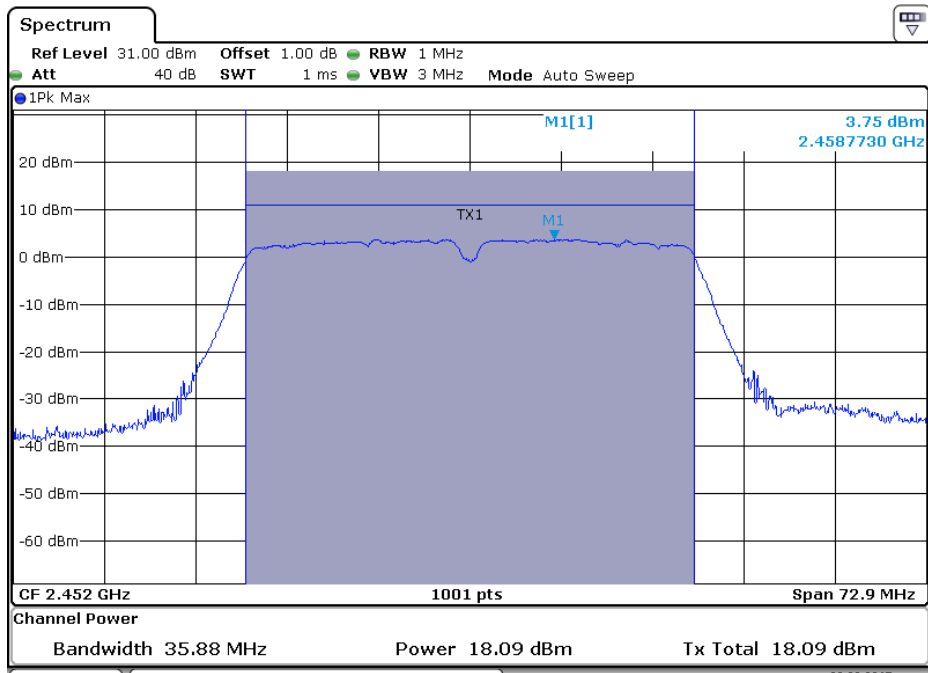

#### 4.4 Peak Power Spectral Density

**Test Requirement:** FCC Part 15 C section 15.247  
(e) For digitally modulated systems, the power spectral density conducted from the intentional radiator to the antenna shall not be greater than 8 dBm in any 3 kHz band during any time interval of continuous transmission.  
This power spectral density shall be determined in accordance with the provisions of paragraph (b) of this section. The same method of determining the conducted output power shall be used to determine the power spectral density.

**Test Method:** ANSI C63.10: Clause 11.10.2

**Test Status:** Pre-Scan has been conducted to determine the worst-case mode from all possible combinations between available modulations, data rates and antenna ports (if EUT with antenna diversity architecture). Following channel(s) was (were) selected for the final test as listed below.

**Test Configuration:**

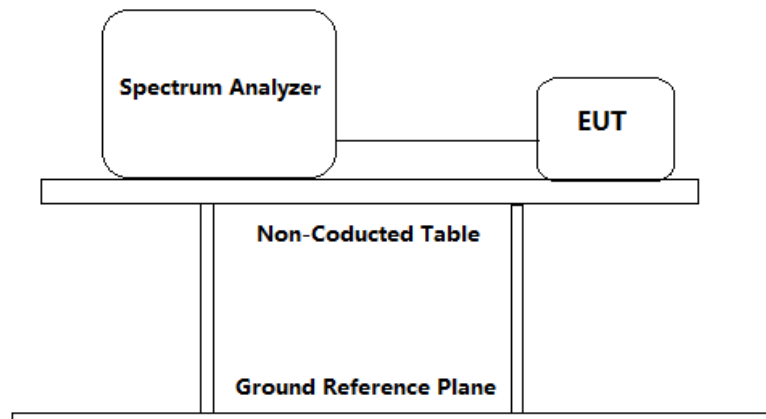

**Test Procedure:**

1. Remove the antenna from the EUT and then connect a low attention attenuation RF cable (cable loss =1 dB) from the antenna port to the spectrum analyzer or power meter.
2. Set the spectrum analyzer:
  - a) Set analyzer center frequency to DTS channel center frequency.
  - b) Set the span=  $1.5 \times$  DTS bandwidth.
  - c) Set the RBW to  $3 \text{ kHz} \leq \text{RBW} \leq 100 \text{ kHz}$ .
  - d) Set the VBW  $\geq [3 \times \text{RBW}]$ .
  - e) Detector = peak.
  - f) Sweep time = auto couple.
  - g) Trace mode = max hold.
  - h) Allow trace to fully stabilize.
  - i) Use the peak marker function to determine the maximum amplitude level within the RBW.
  - j) If measured value exceeds requirement, then reduce RBW (but no less than 3 kHz) and repeat.
3. Measure the Power Spectral Density of the test frequency with special test status.
4. Repeat until all the test status is investigated.
5. Report the worst case.

**Used Test Equipment List**

Spectrum Analyzer. Refer to Clause 5 Test Equipment List for details.



Report No.: 170116067GZU-002  
 Issued: 2017-10-19

Channel No.	Frequency (MHz)	Mode	Data Rate	Measured Peak Power Spectral Density (dBm/3KHz)	Limit	Result
1	2412	802.11b	11 Mbps	-6.94	8dBm/ 3 KHz	Pass
6	2437		11 Mbps	-5.29		Pass
11	2462		11 Mbps	-4.16		Pass
1	2412	802.11g	54 Mbps	-15.92		Pass
6	2437		54 Mbps	-14.05		Pass
11	2462		54 Mbps	-13.79		Pass
1	2412	802.11n (HT20)	72.2 Mbps	-15.75		Pass
6	2437		72.2 Mbps	-14.64		Pass
11	2462		72.2 Mbps	-15.29		Pass
3	2422	802.11n (HT40)	150 Mbps	-18.80		Pass
6	2437		150 Mbps	-19.32		Pass
9	2452		150 Mbps	-19.41		Pass

Test result: Level = Read Level + Cable Loss(1dB).  
 The unit does meet the FCC requirements.

Result plot as follows:

**802.11b mode with 11Mbps data rate**

Channel 1: 2.412GHz:

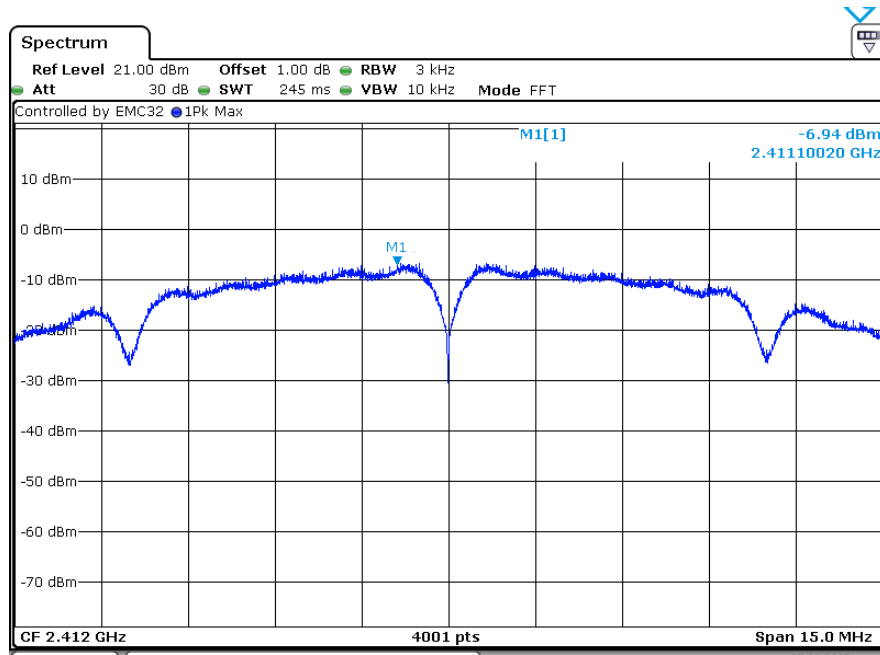

Channel 6: 2.437GHz:

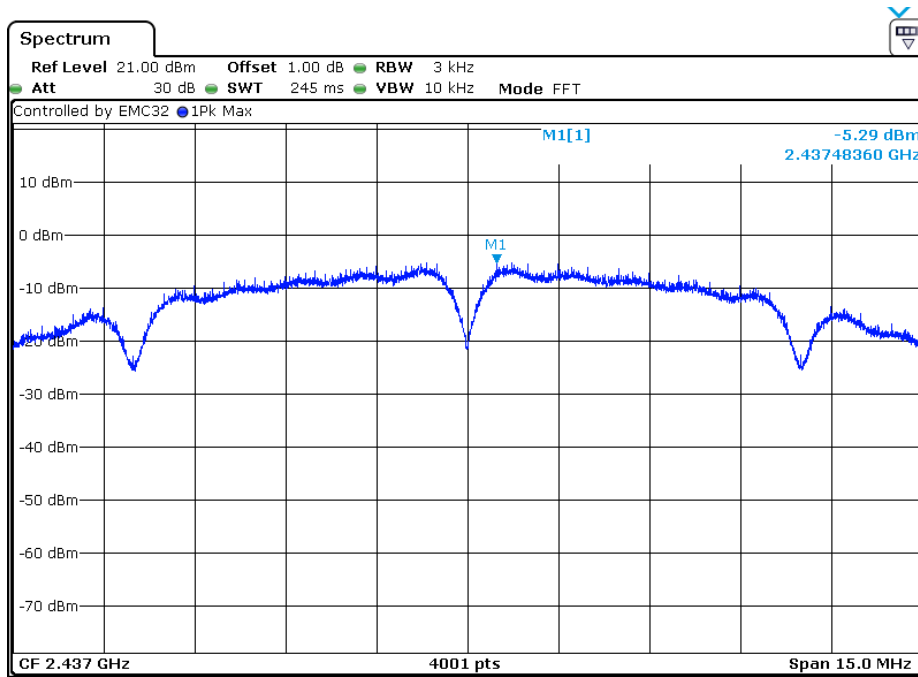



Channel 11: 2.462GHz:

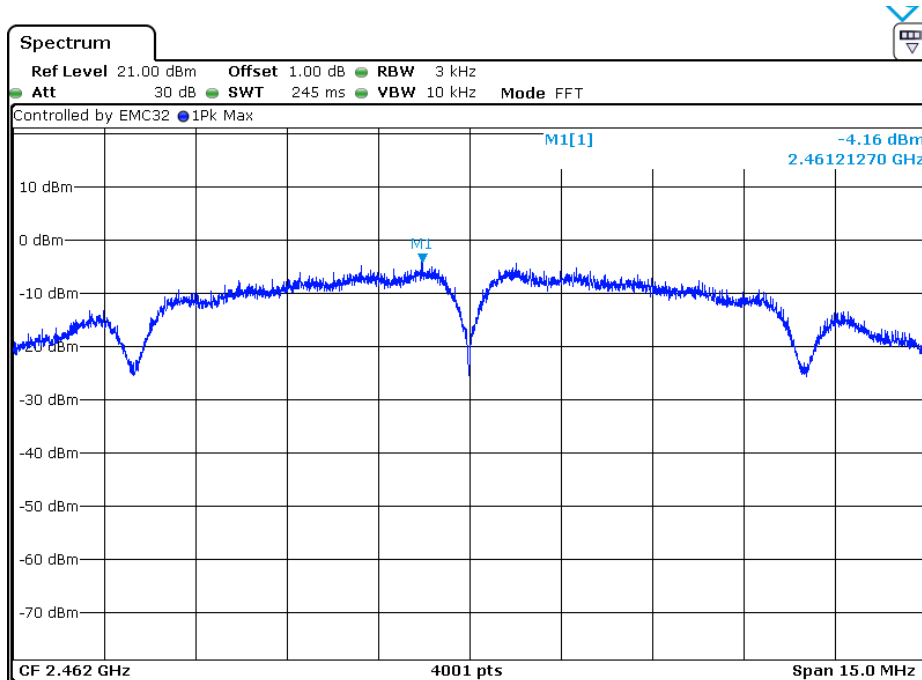

**802.11g mode with 54Mbps data rate**  
Channel 1: 2.412GHz:

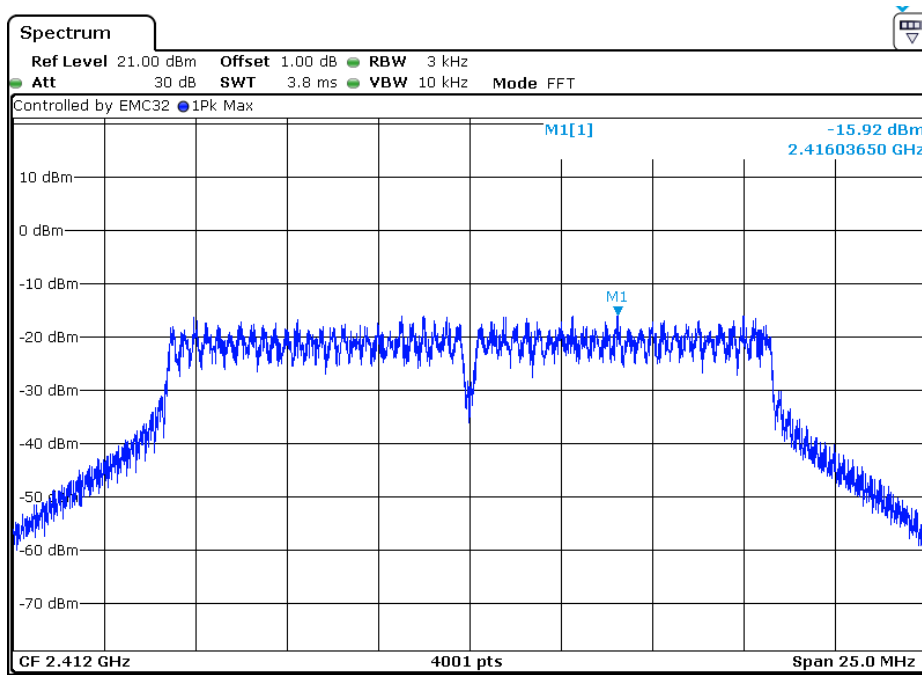

Channel 6: 2.437GHz:

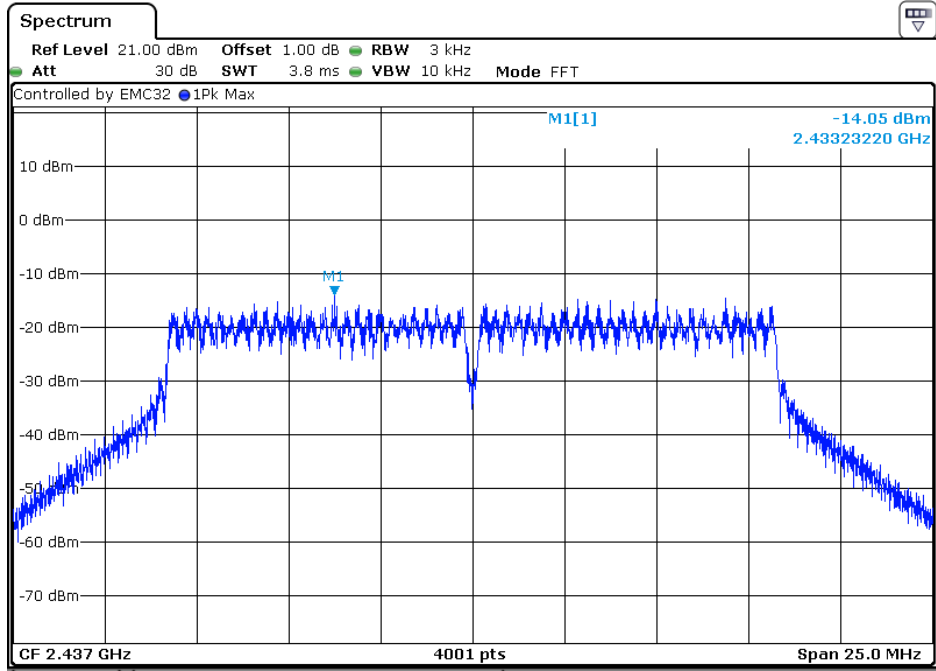

Channel 11: 2.462GHz:

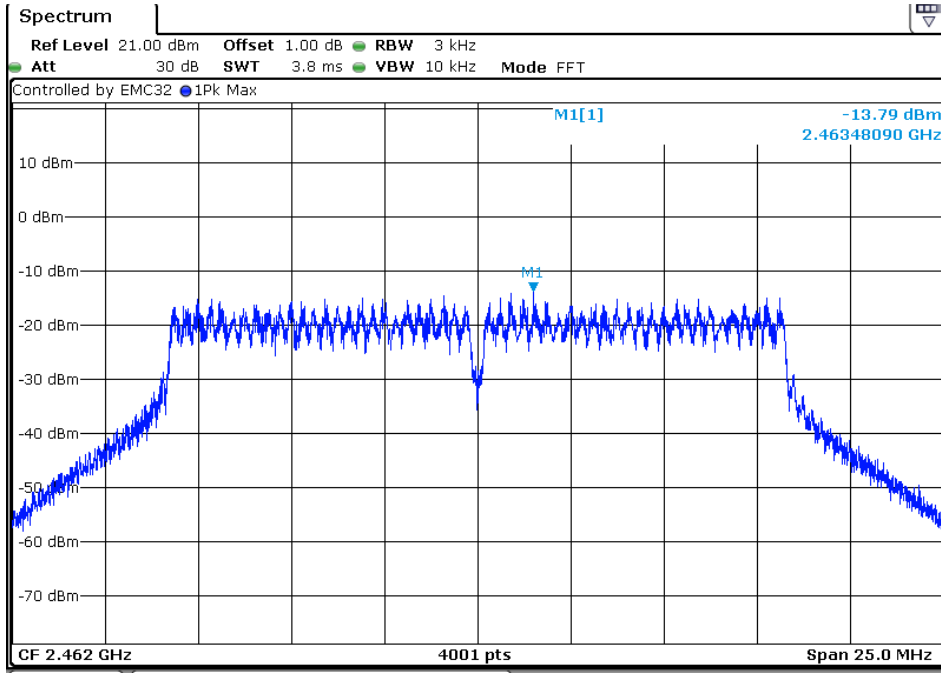

**802.11n(HT20) mode with 72.2Mbps data rate**

Channel 1: 2.412GHz:

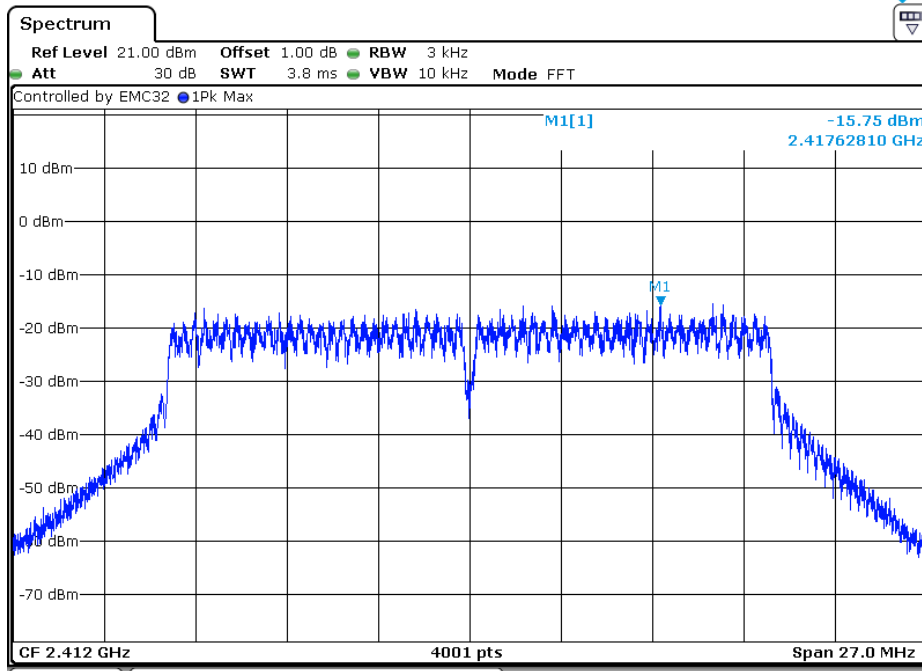

Channel 6: 2.437GHz:

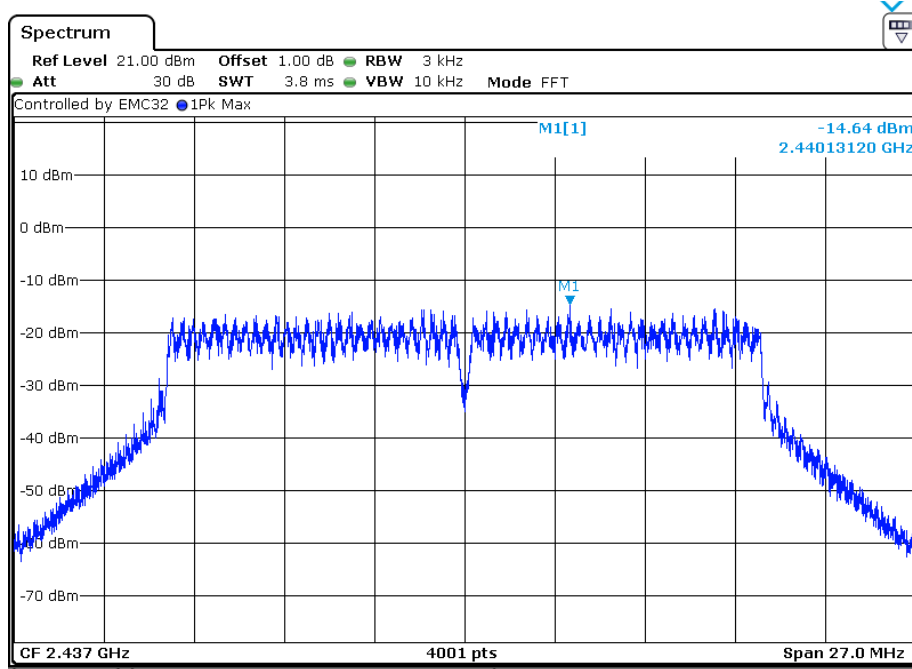

Channel 11: 2.462GHz:

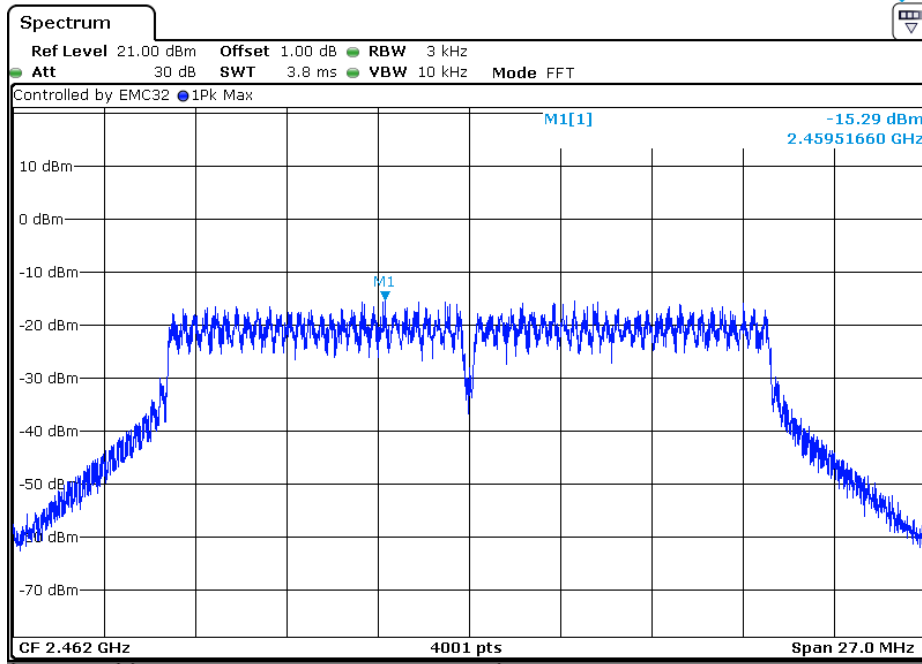

802.11n(HT40) mode with 150Mbps data rate

Channel 3: 2.422GHz:

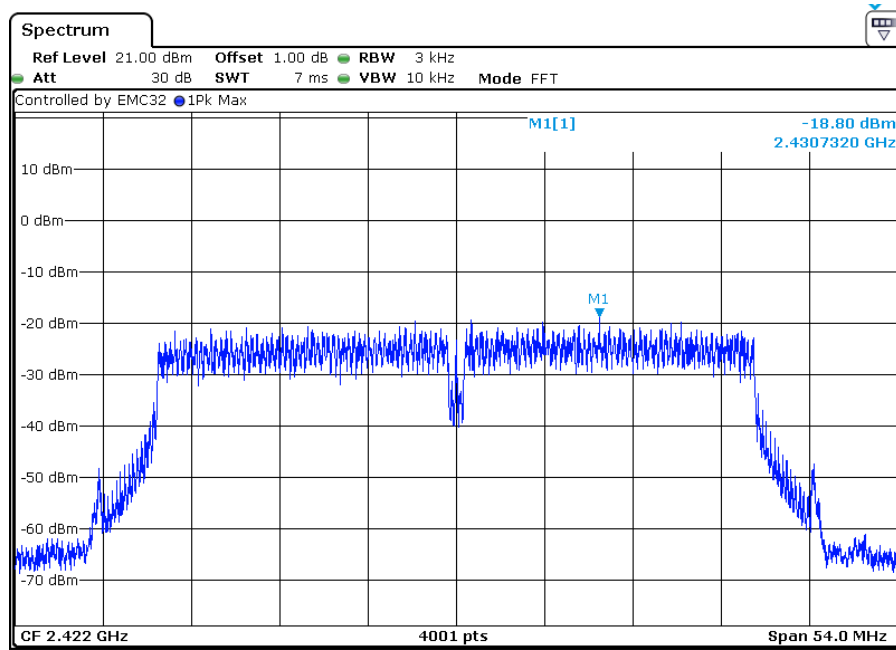

Channel 6: 2.437GHz:

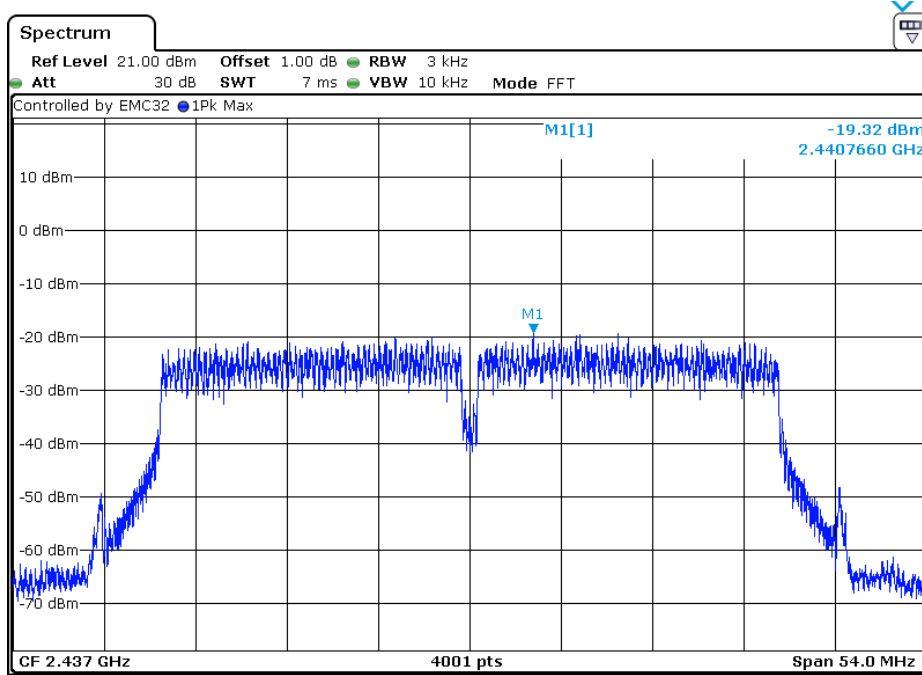

Channel 9: 2.452GHz:

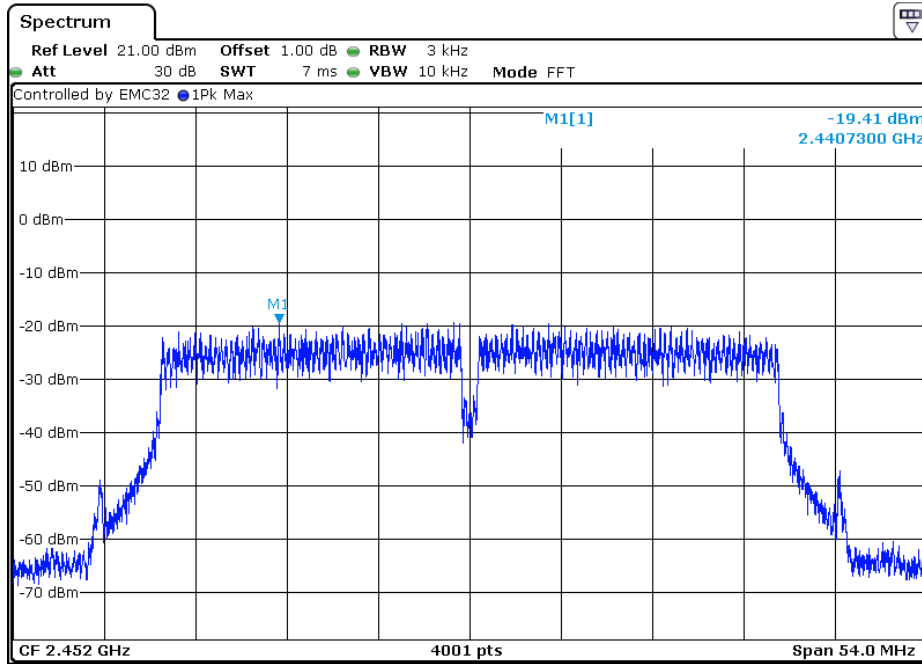

#### 4.5 Out of Band Conducted Emissions

Test Requirement: FCC Part 15 C section 15.247

(d) In any 100 kHz bandwidth outside the frequency band in which the spread spectrum or digitally modulated intentional radiator is operating. The radio frequency power that is produced by the intentional radiator shall be at least 20 dB below that in the 100 kHz bandwidth within the band that contains the highest level of the desired power. Based on either an RF conducted or a radiated measurement. Provided the transmitter demonstrates compliance with the peak conducted power limits.

Test Method: ANSI C63.10: Clause 11.11

Test Status: Pre-Scan has been conducted to determine the worst-case mode from all possible combinations between available modulations, data rates and antenna ports (if EUT with antenna diversity architecture). Following channel(s) was (were) selected for the final test as listed below.

Test Configuration:

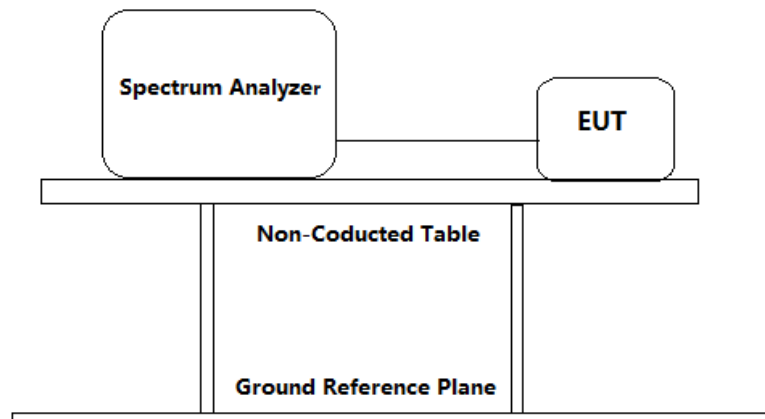

Test Procedure:

1. Remove the antenna from the EUT and then connect a low RF cable (cable loss =2dB) from the antenna port to the spectrum analyzer or power meter.
2. Establish a reference level by using the following procedure:
  - a) Set instrument center frequency to DTS channel center frequency.
  - b) Set the span to  $\geq 1.5 \times$  DTS bandwidth.
  - c) Set the RBW = 100 kHz.
  - d) Set the VBW  $\geq [3 \times$  RBW].
  - e) Detector = peak.
  - f) Sweep time = auto couple.

- g) Trace mode = max hold.
- h) Allow trace to fully stabilize.
- i) Use the peak marker function to determine the maximum PSD level.

Note that the channel found to contain the maximum PSD level can be used to establish the reference level

3. Emission level measurement
  - a) Set the center frequency and span to encompass frequency range to be measured.
  - b) Set the RBW = 100 kHz.
  - c) Set the VBW  $\geq [3 \times \text{RBW}]$ .
  - d) Detector = peak.
  - e) Sweep time = auto couple.
  - f) Trace mode = max hold.
  - g) Allow trace to fully stabilize.
  - h) Use the peak marker function to determine the maximum amplitude level.
4. Measure the Conducted unwanted Emissions of the test frequency with special test status.
5. Repeat until all the test status is investigated.
6. Report the worst case.

### Used Test Equipment List

Spectrum Analyzer. Refer to Clause 5 Test Equipment List for details.

**Result plot as follows:**

**802.11b mode with 11Mbps data rate**

Channel 1: 2.412GHz:

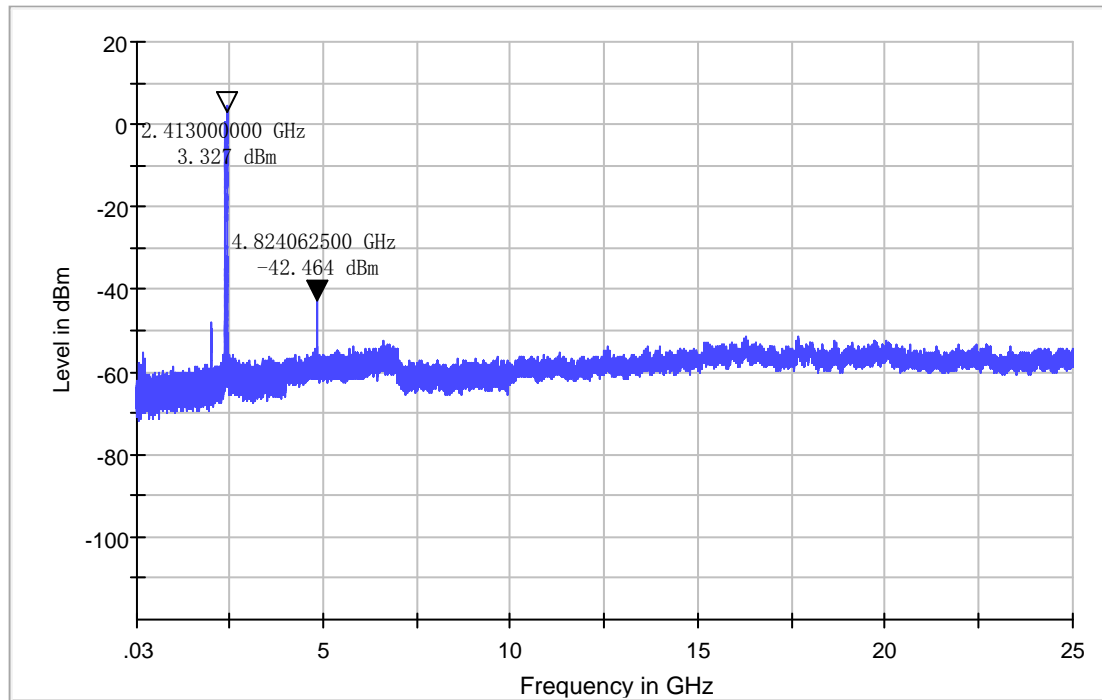

In any 100kHz bandwidth, the Conducted Spurious Emissions from 30 MHz to 25 GHz were greater than 20dB below the peak emission within the band that contains the highest level of the desired power.



**802.11b mode with 11Mbps data rate**  
Channel 6: 2.437GHz:

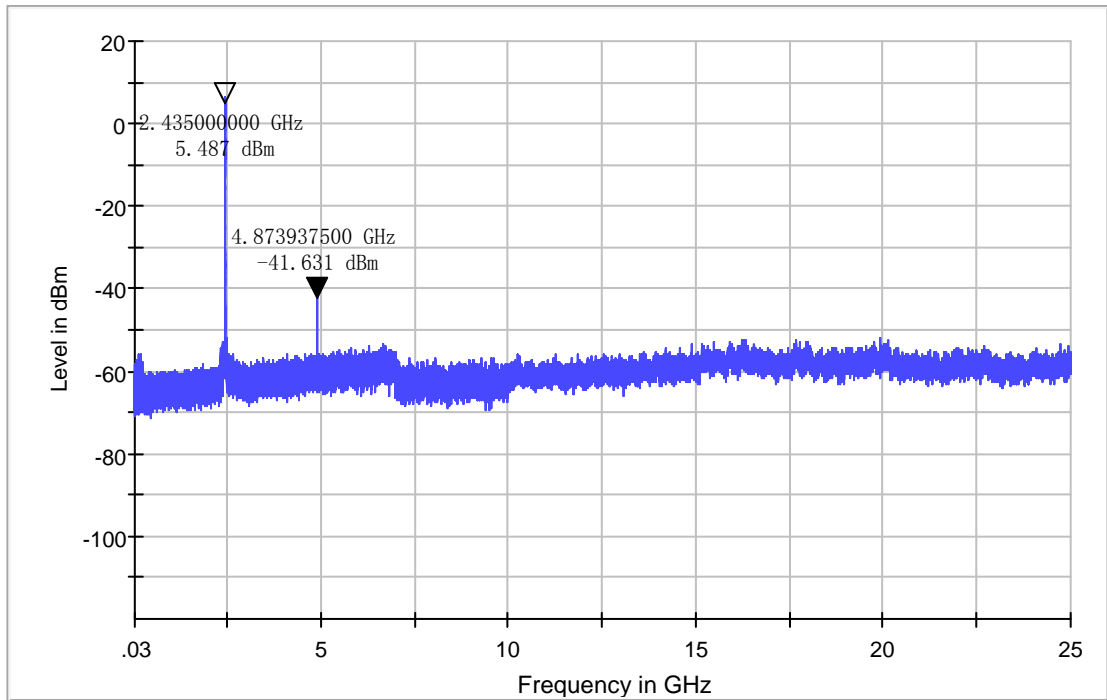

In any 100kHz bandwidth, the Conducted Spurious Emissions from 30 MHz to 25 GHz were greater than 20dB below the peak emission within the band that contains the highest level of the desired power.

Channel 11:2.462 GHz:

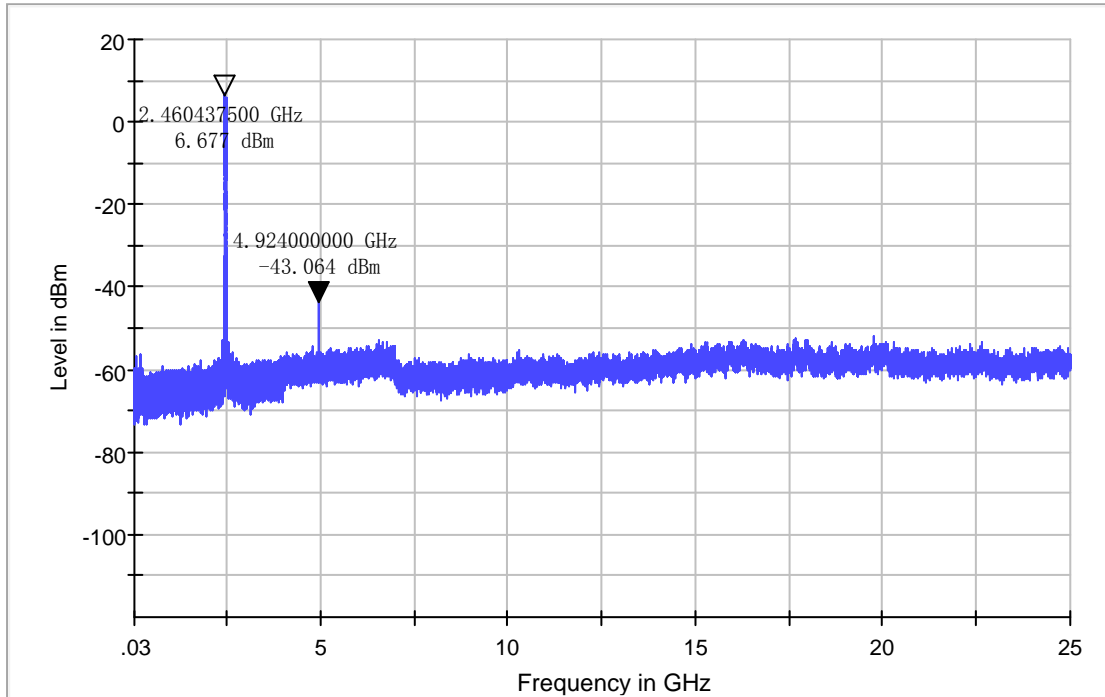

In any 100kHz bandwidth, the Conducted Spurious Emissions from 30 MHz to 25 GHz were greater than 20dB below the peak emission within the band that contains the highest level of the desired power.

**802.11g mode with 54Mbps data rate**  
Channel 1: 2.412GHz:

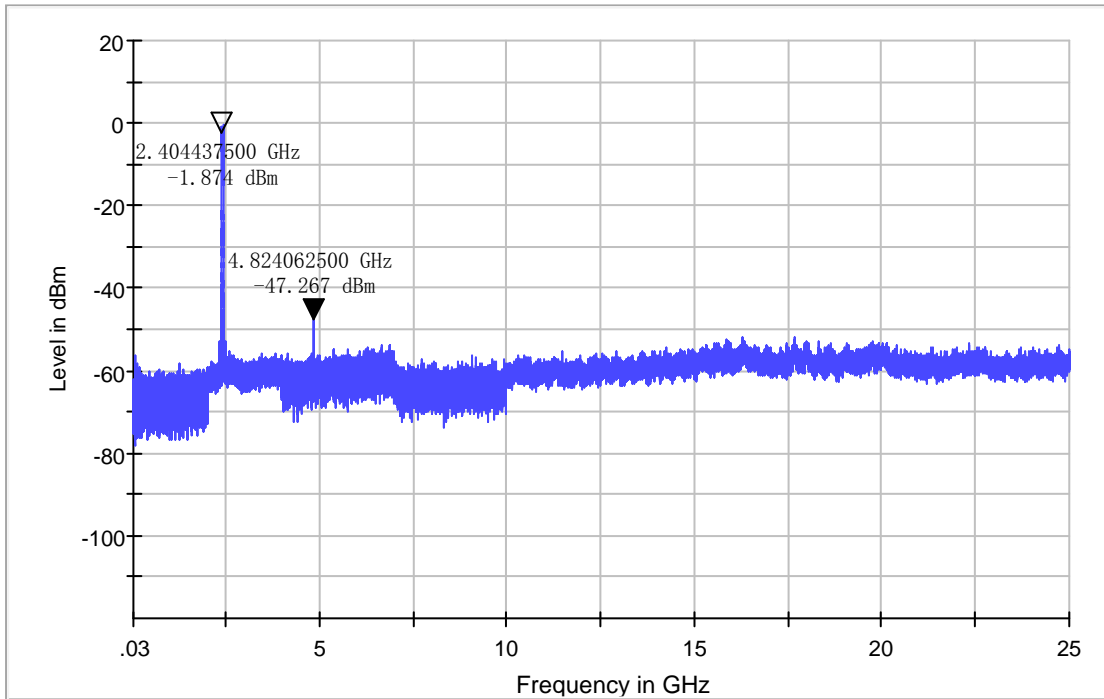

In any 100kHz bandwidth, the Conducted Spurious Emissions from 30 MHz to 25 GHz were greater than 20dB below the peak emission within the band that contains the highest level of the desired power.

Channel 6: 2.437GHz:

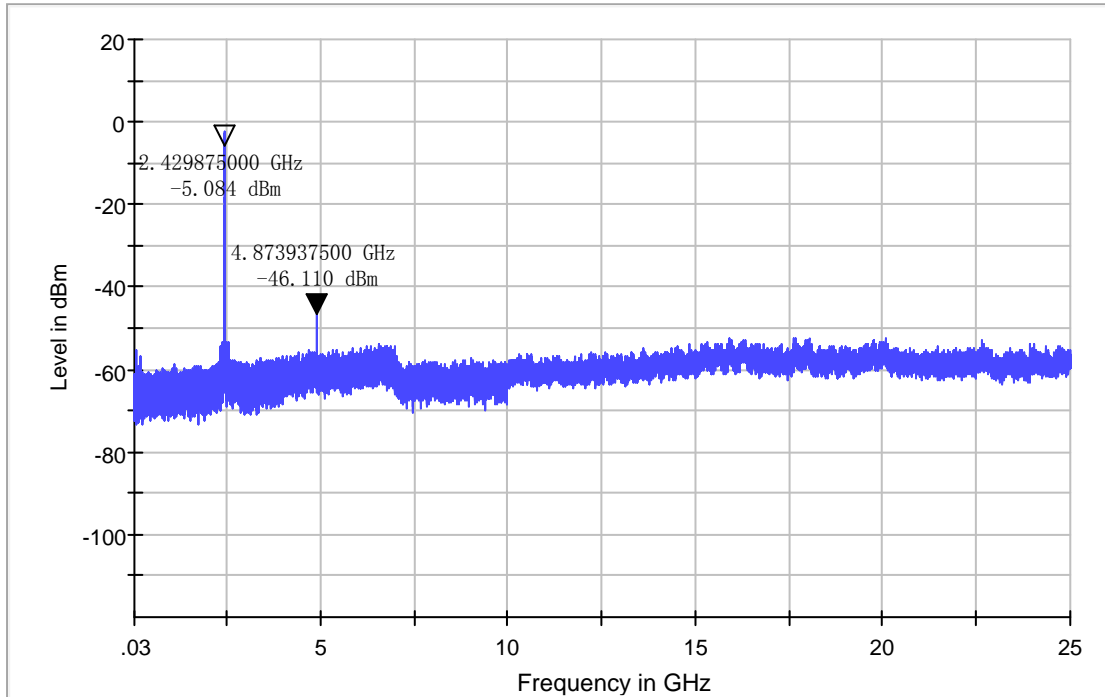

In any 100kHz bandwidth, the Conducted Spurious Emissions from 30 MHz to 25 GHz were greater than 20dB below the peak emission within the band that contains the highest level of the desired power.

Channel 11:2.462 GHz:

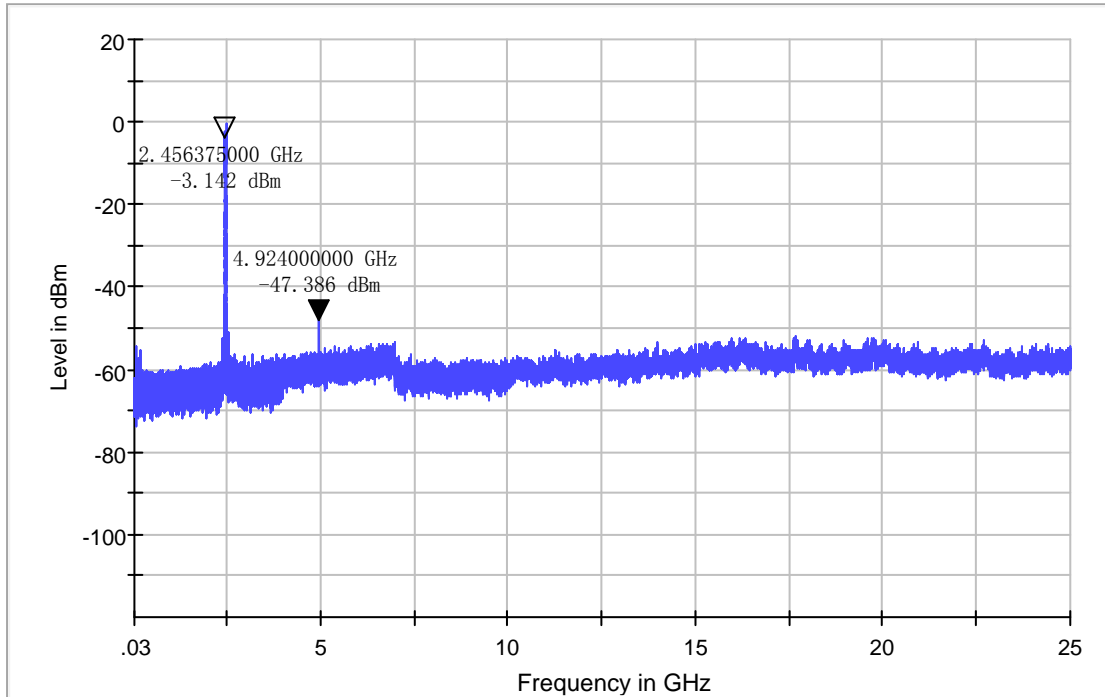

In any 100kHz bandwidth, the Conducted Spurious Emissions from 30 MHz to 25 GHz were greater than 20dB below the peak emission within the band that contains the highest level of the desired power.

**802.11n(HT20) mode with 72.2Mbps data rate**  
Channel 1: 2.412GHz:

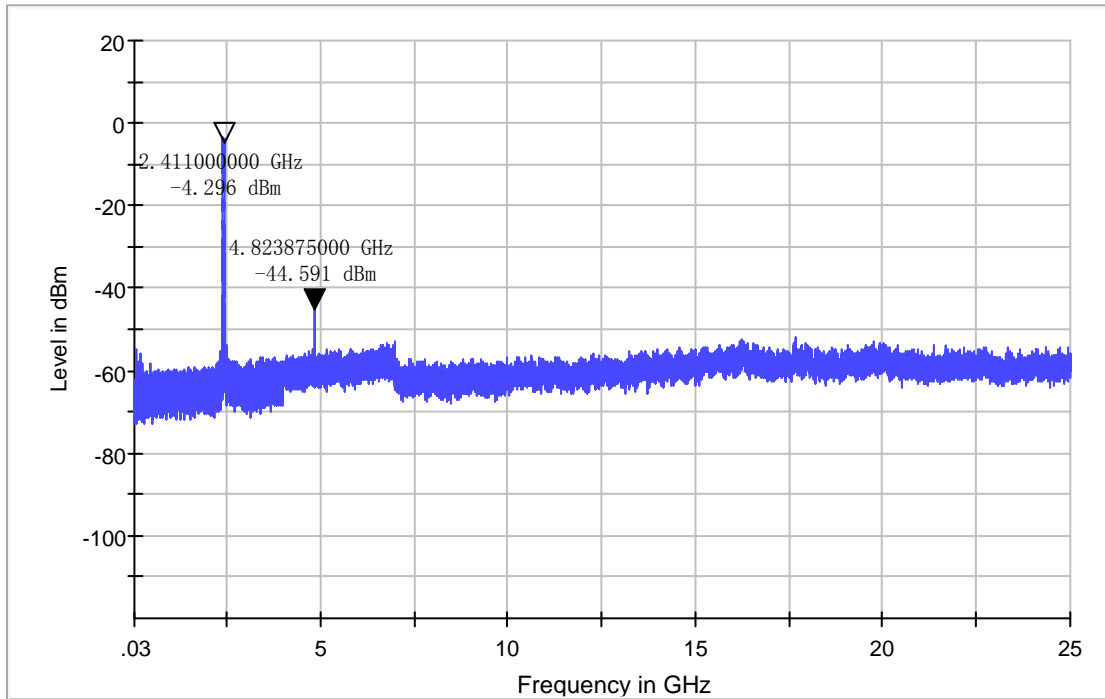

In any 100kHz bandwidth, the Conducted Spurious Emissions from 30 MHz to 25 GHz were greater than 20dB below the peak emission within the band that contains the highest level of the desired power.

Channel 6: 2.437GHz:

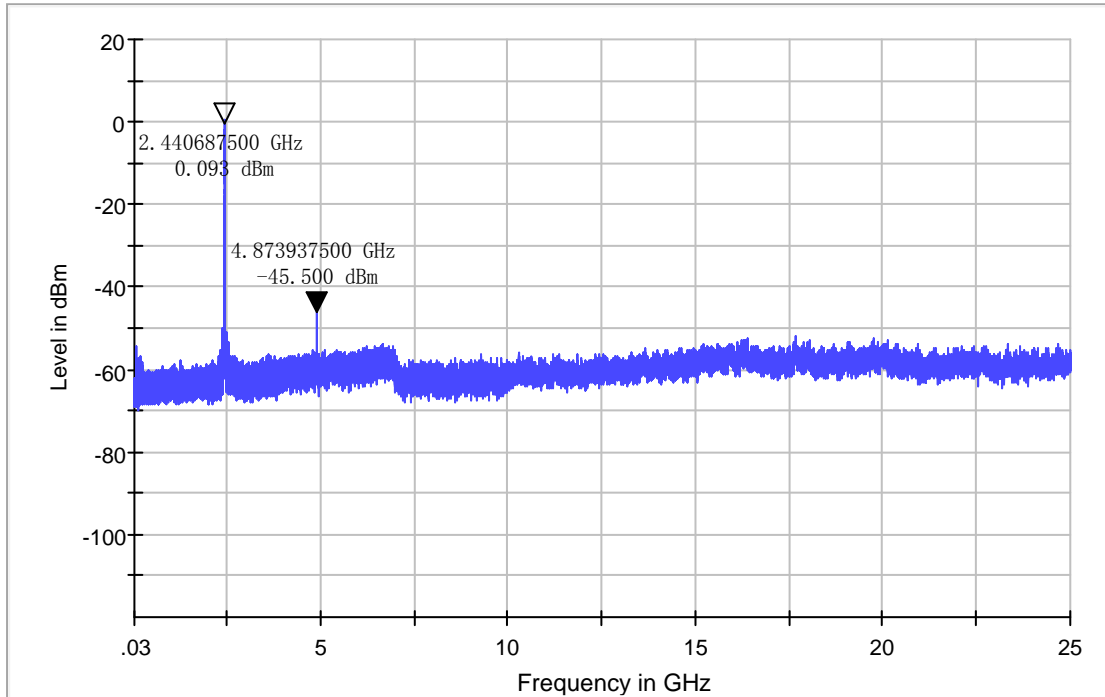

In any 100kHz bandwidth, the Conducted Spurious Emissions from 30 MHz to 25 GHz were greater than 20dB below the peak emission within the band that contains the highest level of the desired power.

Channel 11:2.462 GHz:

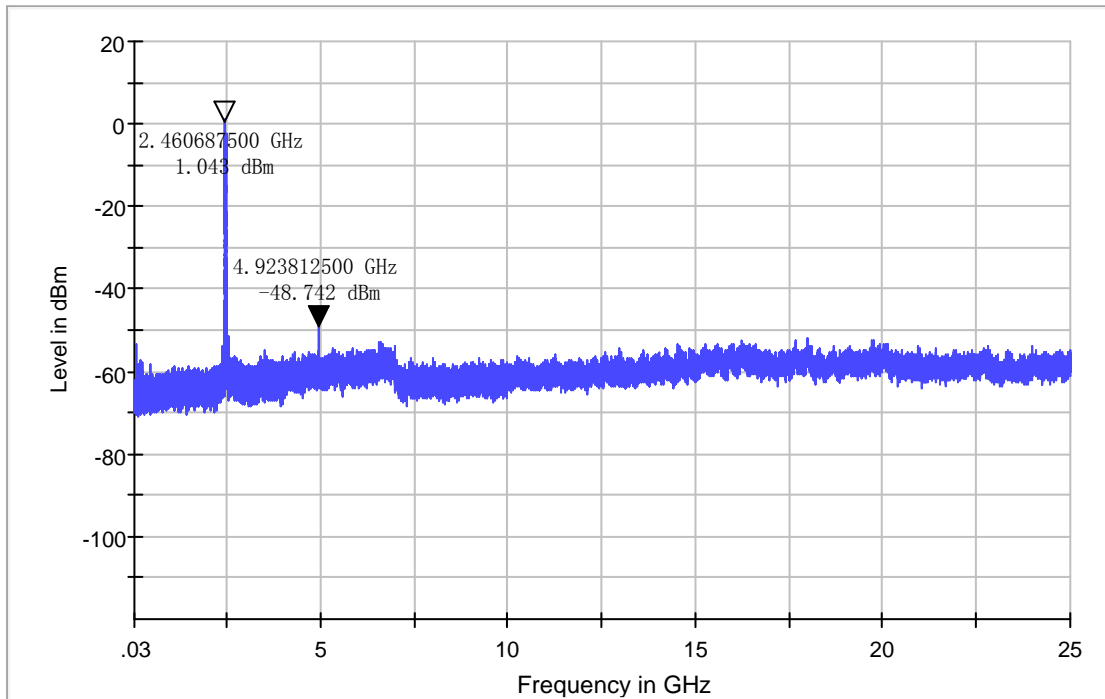

In any 100kHz bandwidth, the Conducted Spurious Emissions from 30 MHz to 25 GHz were greater than 20dB below the peak emission within the band that contains the highest level of the desired power.



**802.11n(HT40) mode with 150Mbps data rate**  
Channel 3: 2.422GHz:

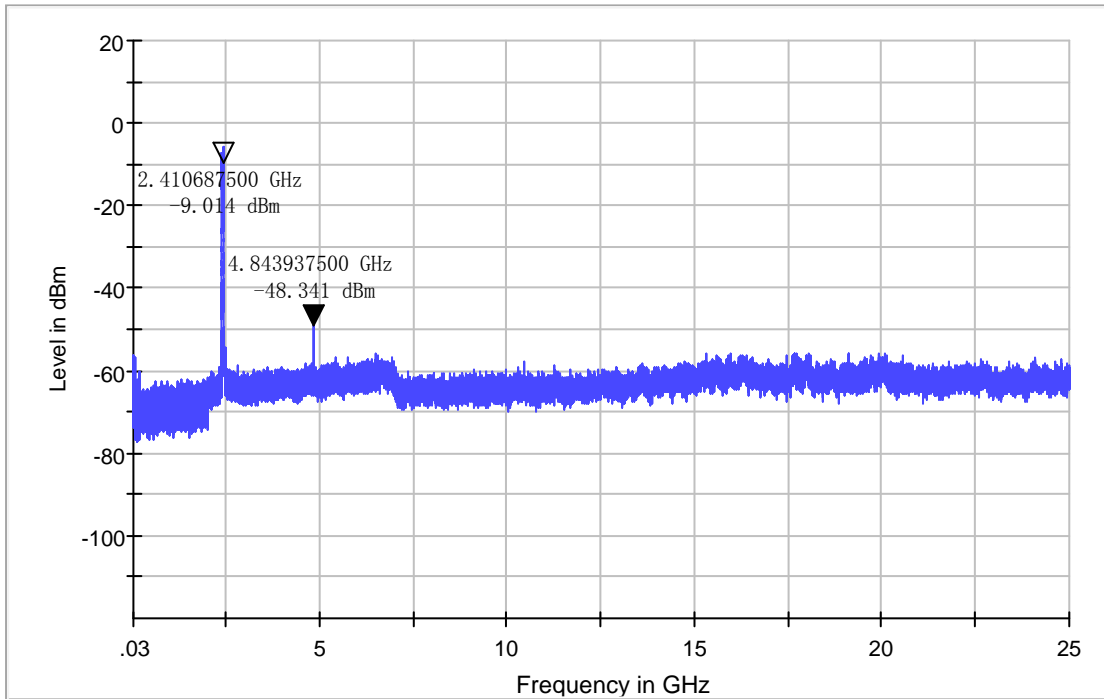

In any 100kHz bandwidth, the Conducted Spurious Emissions from 30 MHz to 25 GHz were greater than 20dB below the peak emission within the band that contains the highest level of the desired power.

Channel 6: 2.437GHz:

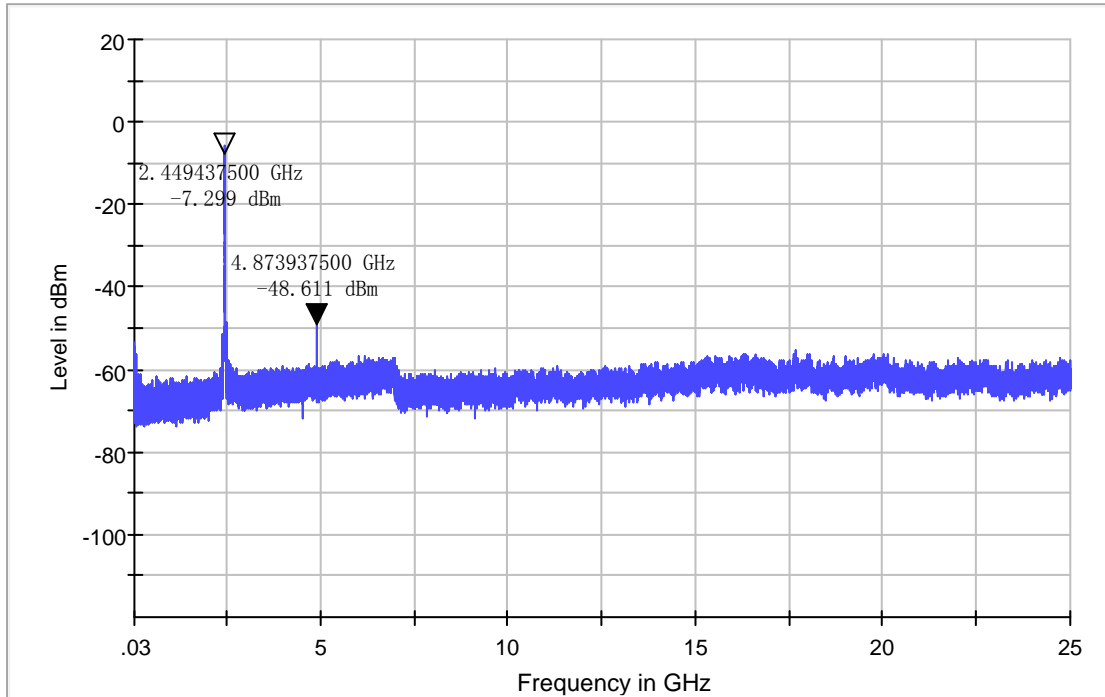

In any 100kHz bandwidth, the Conducted Spurious Emissions from 30 MHz to 25 GHz were greater than 20dB below the peak emission within the band that contains the highest level of the desired power.

Channel 9: 2.452 GHz:

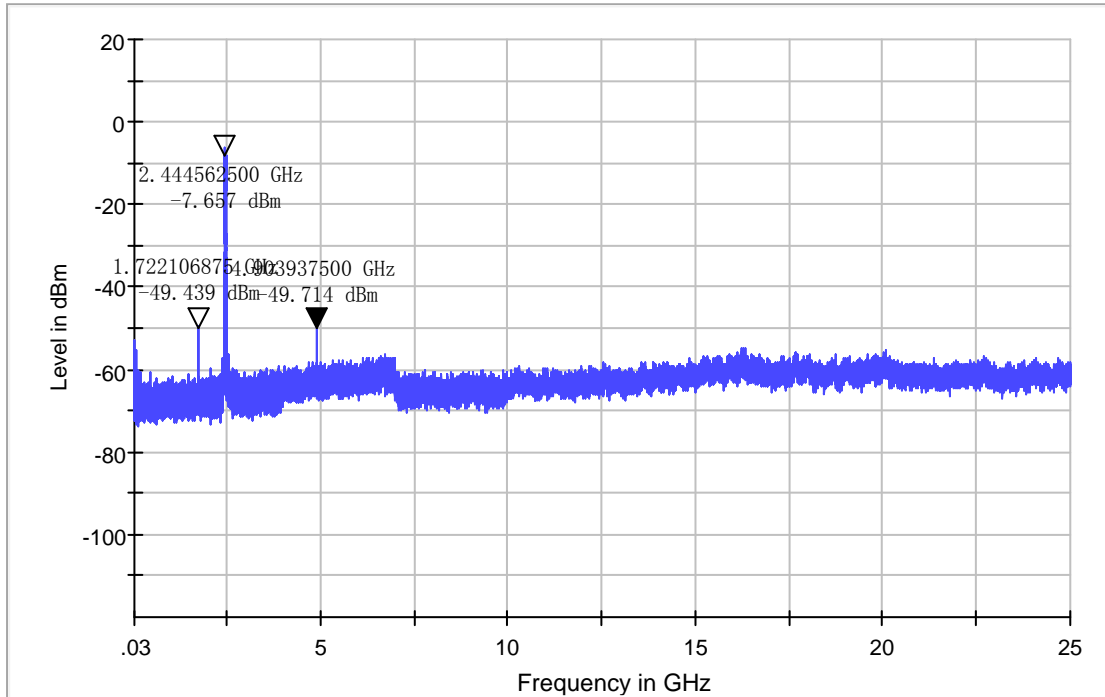

In any 100kHz bandwidth, the Conducted Spurious Emissions from 30 MHz to 25 GHz were greater than 20dB below the peak emission within the band that contains the highest level of the desired power.



Report No.: 170116067GZU-002  
Issued: 2017-10-19

#### **4.6 Out of Band Radiated Emissions**

For out of band radiated emissions into Non-Restricted Frequency Bands were performed at a 3m separation distance to determine whether these emissions complied with the 20dB attenuation requirement.

- Not required, since all emissions are more than 20dB below fundamental
- See attached data sheet

#### 4.7 Radiated Emissions in Restricted Bands

Test Requirement:	FCC Part 15 C section 15.247  (d) In addition, radiated emissions which fall in the restricted bands, as defined in Section 15.205(a), must also comply with the radiated emission limits specified in Section 15.209(a) (see Section 15.205(c)).
Test Method:	ANSI C63.10: Clause 11.12.1, 6.4, 6.5 and 6.6
Test Status:	Pre-Scan has been conducted to determine the worst-case mode from all possible combinations between available modulations, data rates and antenna ports (if EUT with antenna diversity architecture). Following channel(s) was (were) selected for the final test as listed below.
Test site:	Measurement Distance: 3m (Semi-Anechoic Chamber)
Limit:	40.0 dB $\mu$ V/m between 30MHz & 88MHz; 43.5 dB $\mu$ V/m between 88MHz & 216MHz; 46.0 dB $\mu$ V/m between 216MHz & 960MHz; 54.0 dB $\mu$ V/m above 960MHz.
Detector:	For Peak and Quasi-Peak value: RBW = 1 MHz for $f \geq 1$ GHz, 200 Hz for 9 kHz to 150 kHz 9 kHz for 150 kHz to 30 MHz 120 kHz for 30 MHz to 1GHz VBW $\geq$ RBW Sweep = auto Detector function = peak for $f \geq 1$ GHz, QP for $f < 1$ GHz Trace = max hold  For AV value: RBW = 1 MHz for $f \geq 1$ GHz, 100 kHz for $f < 1$ GHz VBW=10 Hz Sweep = auto Trace = max hold

Field Strength Calculation:

The field strength is calculated by adding the reading on the Spectrum Analyzer to the factors associated with preamplifiers (if any), antennas, cables, pulse desensitization and average factors (when specified limit is in average and measurements are made with peak detectors). A sample calculation is included below:

$$FS = RA + AF + CF - AG + PD + AV$$

$$FS = RA + \text{Correct Factor} + AV$$

FS = Field Strength in dB $\mu$ V/m

Where:

RA = Receiver Amplitude (including preamplifier) in dB $\mu$ V

AF = Antenna Factor in dB

CF = Cable Attenuation Factor in dB

AG = Amplifier Gain in dB

PD = Pulse Desensitization in dB

AV = Average Factor in -dB

Correct Factor = AF + CF - AG + PD

In the radiated emission table which follows, the reading shown on the data table may reflect the preamplifier gain. An example of the calculations, where the reading does not reflect the preamplifier gain, follows:

$$FS = RA + AF + CF - AG + PD + AV$$

Assume a receiver reading of 62.0 dB $\mu$ V is obtained. The antenna factor of 7.4 dB and cable factor of 1.6 dB is added. The amplifier gain of 29 dB is subtracted. The pulse desensitization factor of the spectrum analyzer was 0 dB, and the resultant average factor was -10 dB. The net field strength for comparison to the appropriate emission limit is 32 dB $\mu$ V/m.

$$RA = 62.0 \text{ dB}\mu\text{V}$$

$$AF = 7.4 \text{ dB}$$

$$CF = 1.6 \text{ dB}$$

$$AG = 29.0 \text{ dB}$$

$$PD = 0 \text{ dB}$$

$$AV = -10 \text{ dB}$$

$$\text{Correct Factor} = 7.4 + 1.6 - 29.0 + 0 = -20 \text{ dB}$$

$$FS = 62 + (-20) + (-10) = 32 \text{ dB}\mu\text{V/m}$$

Section 15.205 Restricted bands of operation.

(a) Except as shown in paragraph (d) of this section. Only spurious emissions are permitted in any of the frequency bands listed below:

MHz	MHz	MHz	GHz
0.090 - 0.110	16.42 - 16.423	399.9 - 410	4.5 - 5.15
<sup>1</sup> 0.495 - 0.505	16.69475 -	608 - 614	5.35 - 5.46
2.1735 - 2.1905	16.69525	960 - 1240	7.25 - 7.75
4.125 - 4.128	16.80425 -	1300 - 1427	8.025 - 8.5
4.17725 - 4.17775	16.80475	1435 - 1626.5	9.0 - 9.2
4.20725 - 4.20775	25.5 - 25.67	1645.5 - 1646.5	9.3 - 9.5
6.215 - 6.218	37.5 - 38.25	1660 - 1710	10.6 - 12.7
6.26775 - 6.26825	73 - 74.6	1718.8 - 1722.2	13.25 - 13.4
6.31175 - 6.31225	74.8 - 75.2	2200 - 2300	14.47 - 14.5
8.291 - 8.294	108 - 121.94	2310 - 2390	15.35 - 16.2
8.362 - 8.366	123 - 138	2483.5 - 2500	17.7 - 21.4
8.37625 - 8.38675	149.9 - 150.05	2655 - 2900	22.01 - 23.12
8.41425 - 8.41475	156.52475 -	3260 - 3267	23.6 - 24.0
12.29 - 12.293	156.52525	3332 - 3339	31.2 - 31.8
12.51975 -	156.7 - 156.9	3345.8 - 3358	36.43 - 36.5
12.52025	162.0125 - 167.17	3600 - 4400	
12.57675 -	167.72 - 173.2		
12.57725	240 - 285		
13.36 - 13.41	322 - 335.4		

Test Configuration:

- 1) 30 MHz to 1 GHz emissions:

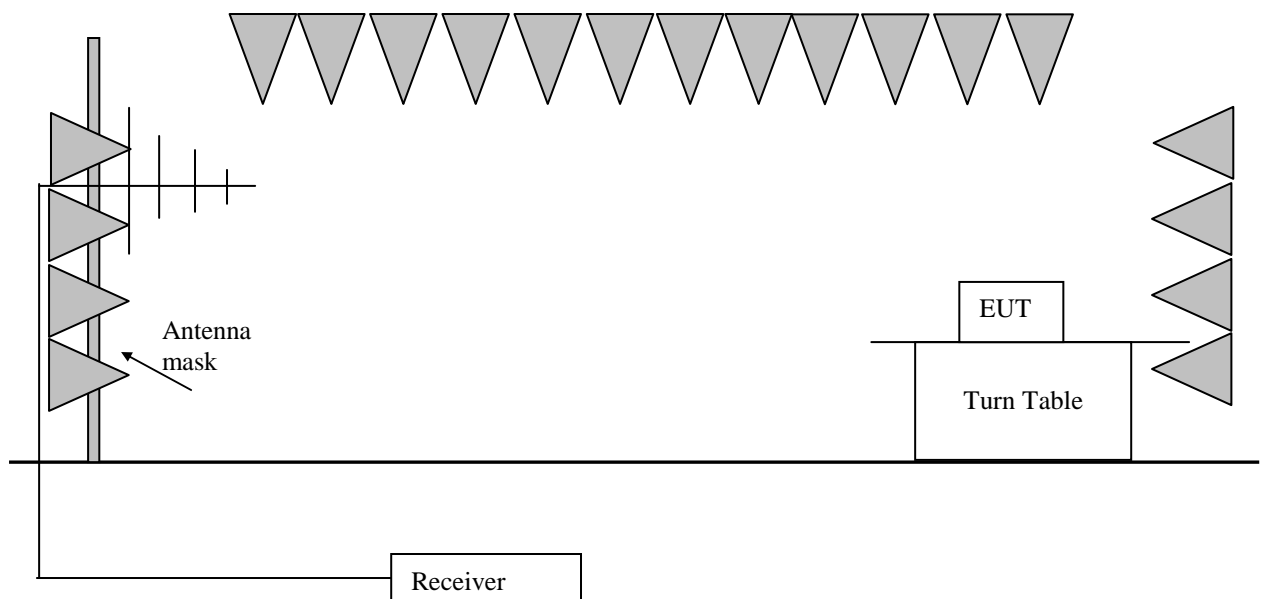

2) 1 GHz to 40 GHz emissions:

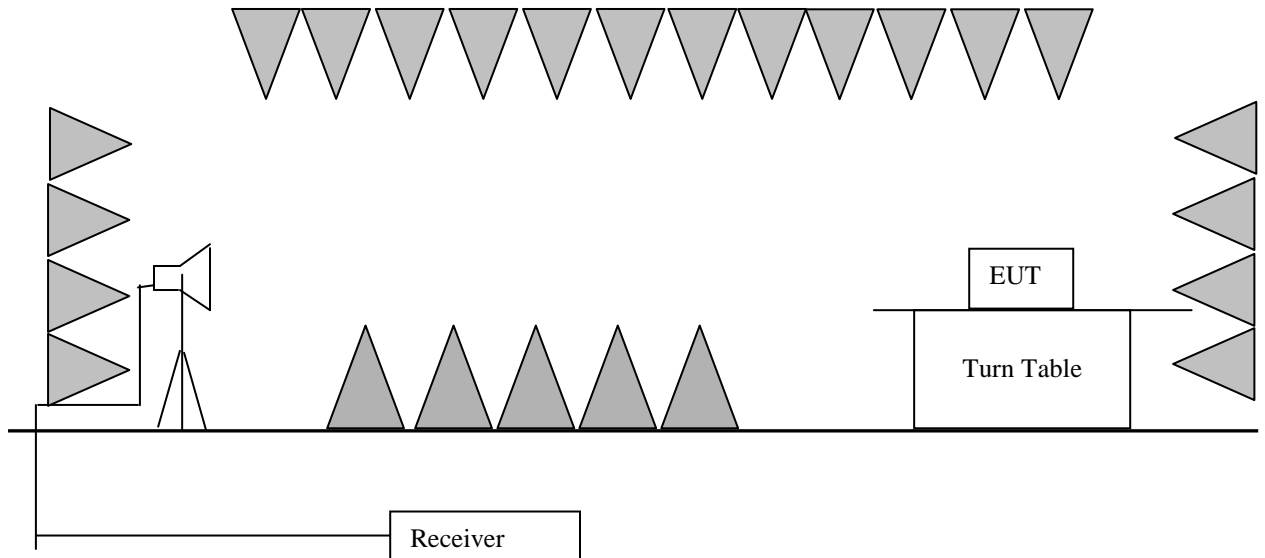



**Test Procedure:**

Test site with RF absorbing material covering the ground plane that met the site validation criterion called out in CISPR 16-1-4:2007 was used to perform radiated emission test above 1 GHz.

The receiver was scanned from 9 kHz to 25 GHz. When an emission was found, the table was rotated to produce the maximum signal strength. An initial pre-scan was performed for in peak detection mode using the receiver. The EUT was measured for both the Horizontal and Vertical polarities and performed a pre-test three orthogonal planes. For intentional radiators, measurements of the variation of the input power or the radiated signal level of the fundamental frequency component of the emission, as appropriate, shall be performed with the supply voltage varied between 85% and 115% of the nominal rated supply voltage. The worst case emissions were reported.

**Used Test Equipment List:**

3m Semi-Anechoic Chamber, EMI Test Receiver (9 kHz~7 GHz), Signal and Spectrum Analyzer (10 Hz~40 GHz), Loop antenna (9 kHz-30 MHz). TRILOG Super Broadband test Antenna(30 MHz-3 GHz) (RX), Double-Ridged Waveguide Horn Antenna (800 MHz-18 GHz)(RX) and High Frequency Antenna & preamplifier(18 GHz~26.5 GHz) (RX). Refer to Clause 5 Test Equipment List for details.

**802.11b mode with 11Mbps data rate**

9 kHz~30 MHz Field Strength of Unwanted Emissions for Quasi-Peak Measurement

The measurements with active loop antenna were greater than 20dB below the limit, so the test data were not recorded in the test report.

Test at Channel 1 (2.412 GHz) in transmitting status.

30 MHz~1 GHz Spurious Emissions .Quasi-Peak Measurement.

**Vertical:**

Level (dBμV/m)

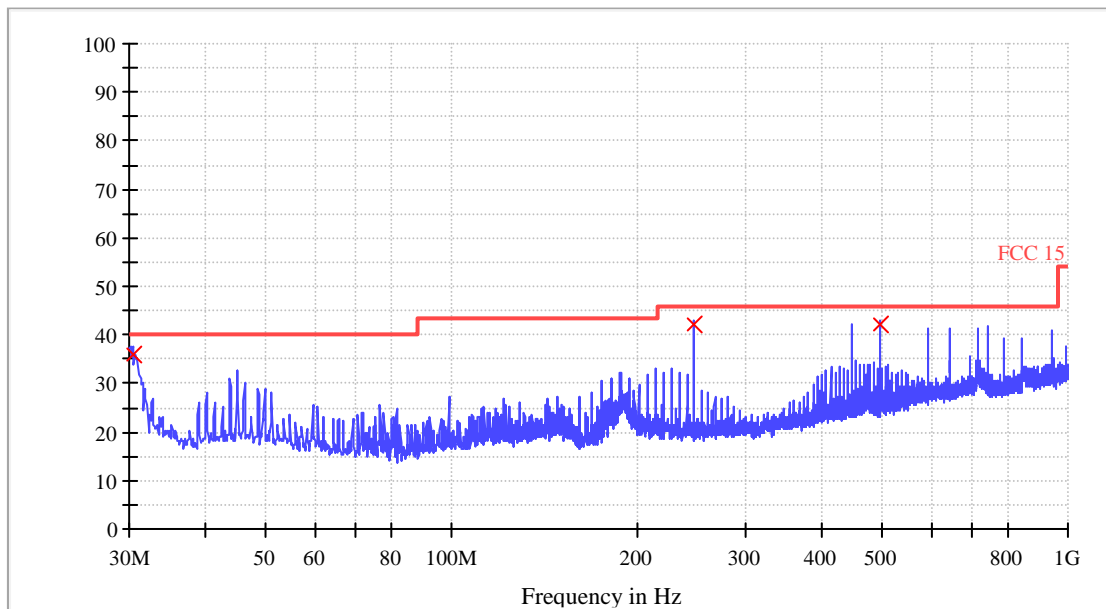

Quasi-peak measurement

Frequency (MHz)	QuasiPeak (dBμV/m)	Bandwidth (kHz)	Pol	Corr. (dB)	Margin - QPK (dB)	Limit - QPK (dBμV/m)
30.360000	36.1	120.000	V	11.2	3.9	40.0
247.520000	42.1	120.000	V	14.0	3.9	46.0
495.000000	42.2	120.000	V	19.5	3.8	46.0

**Horizontal:**  
 Level (dBμV/m)

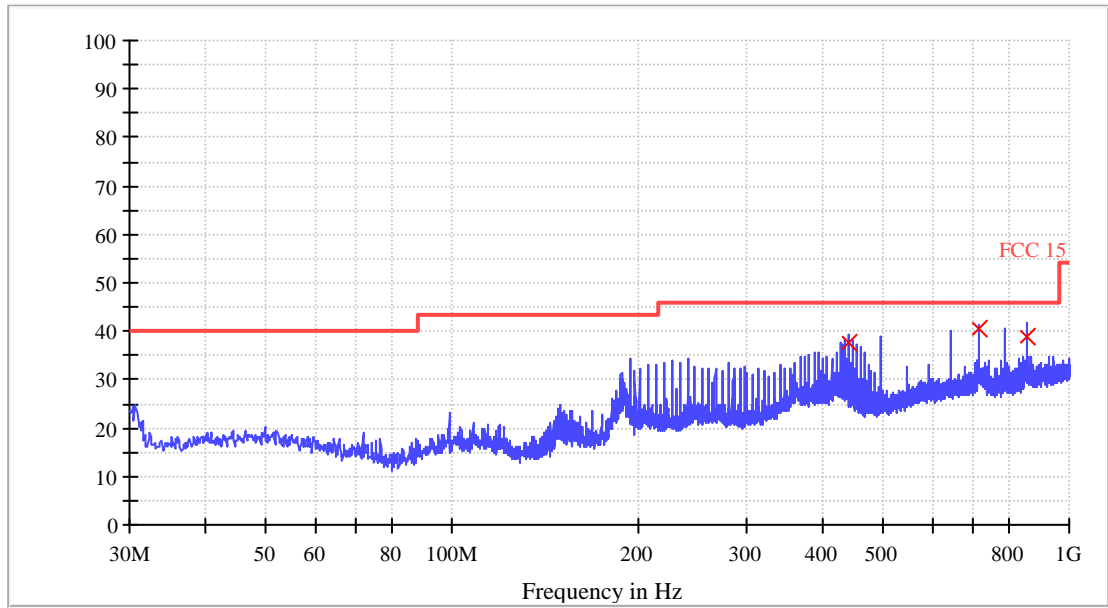

Quasi-peak measurement

Frequency (MHz)	QuasiPeak (dBμV/m)	Bandwidth (kHz)	Pol	Corr. (dB)	Margin - QPK (dB)	Limit - QPK (dBμV/m)
438.840000	37.4	120.000	H	18.5	8.6	46.0
714.560000	40.4	120.000	H	23.2	5.6	46.0
857.520000	38.7	120.000	H	25.1	7.3	46.0



Report No.: 170116067GZU-002  
Issued: 2017-10-19

1~25 GHz Radiated Emissions.

Polarization	Frequency (MHz)	PK Net at 3m (dB $\mu$ V/m)	AV Net at 3m (dB $\mu$ V/m)	Correction Factor (dB)	PK Limit at 3m (dB $\mu$ V/m)	PK Margin (dB)	AV Limit at 3m (dB $\mu$ V/m)	AV Margin (dB)
Horizontal	1205.000	47.3	/	-17.5	74.0	/	54.0	/
Horizontal	2384.000	40.5	/	-7.0	74.0	/	54.0	/
Horizontal	4823.000	57.2	46.4	-8.8	74.0	-16.8	54.0	-7.6
Horizontal	5304.000	46.4	/	-8.4	74.0	/	54.0	/
Vertical	1206.000	40.5	/	-17.5	74.0	/	54.0	/
Vertical	2384.000	49.7	/	-7.0	74.0	/	54.0	/
Vertical	4823.000	47.1	/	-8.8	74.0	/	54.0	/
Vertical	7234.000	41.1	/	-6.2	74.0	/	54.0	/

Remark: When Peak emission level was below AV limit, the AV emission level did not be recorded.

The field strength is calculated by adding the Antenna Factor, Cable Factor & Preamplifier. The basic equation with a sample calculation is as follows:

Final Test Level = Receiver Reading + Antenna Factor + Cable Factor - Preamplifier Factor.

No any other emissions level which are attenuated less than 20dB below the limit.

Band Edge test Restricted Bands  
 Horizontal

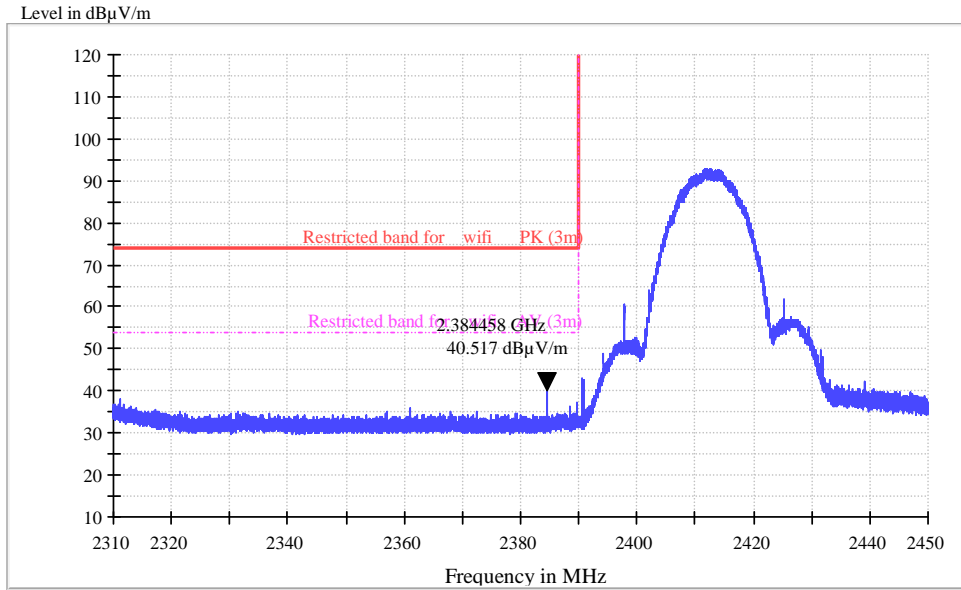

Polarization	Frequency (MHz)	PK Net at 3m (dBµV/m)	AV Net at 3m (dBµV/m)	Correction Factor (dB)	PK Limit at 3m (dBµV/m)	PK Margin (dB)	AV Limit at 3m (dBµV/m)	AV Margin (dB)
Horizontal	2384.458	40.5	/	-7.0	74.0	/	54.0	/

Vertical

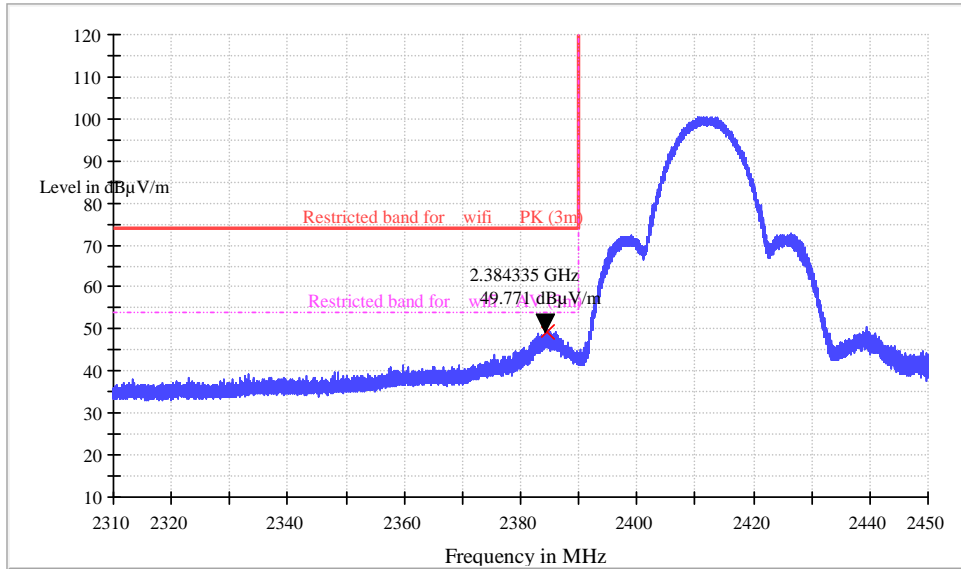

Polarization	Frequency (MHz)	PK Net at 3m (dBµV/m)	AV Net at 3m (dBµV/m)	Correction Factor (dB)	PK Limit at 3m (dBµV/m)	PK Margin (dB)	AV Limit at 3m (dBµV/m)	AV Margin (dB)
Vertical	2384.335	49.7	/	-7.0	74.0	/	54.0	/

Remark: When Peak emission level was below AV limit, the AV emission level did not be recorded.

Test at Channel 6 (2.437 GHz) in transmitting status  
 30 MHz~1 GHz Radiated Emissions .Quasi-Peak Measurement

**Vertical:**

Level (dBμV/m)

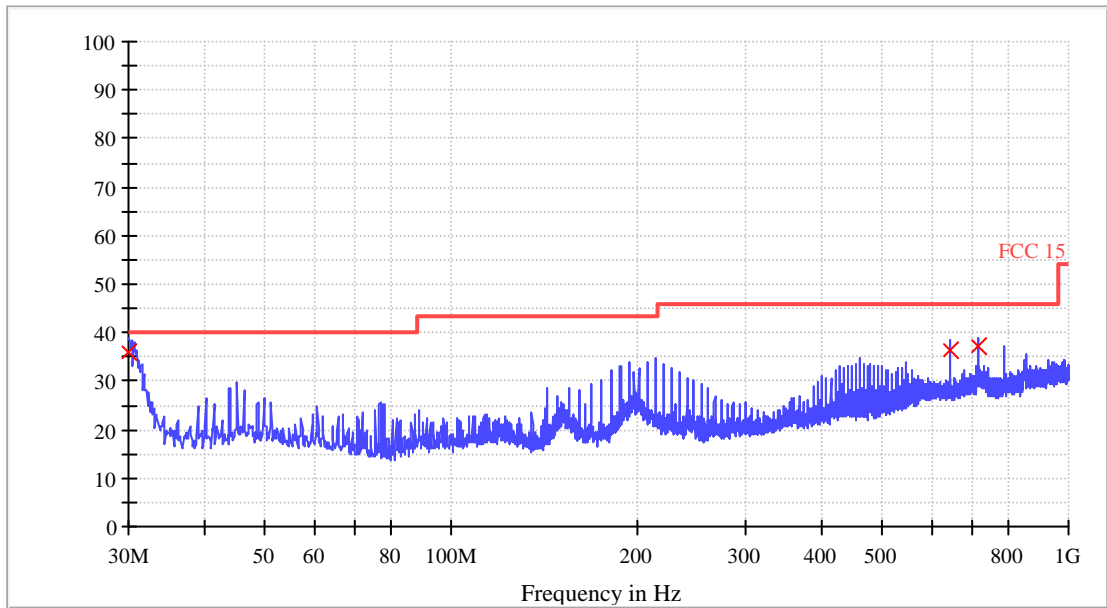

Quasi-peak measurement

Frequency (MHz)	Quasi Peak (dBμV/m)	Bandwidth (kHz)	Pol	Corr. (dB)	Margin - QPK (dB)	Limit - QPK (dBμV/m)
30.000000	35.7	120.000	V	11.2	4.3	40.0
643.160000	36.5	120.000	V	22.4	9.5	46.0
714.560000	37.4	120.000	V	23.2	8.6	46.0

**Horizontal:**  
 Level (dBμV/m)

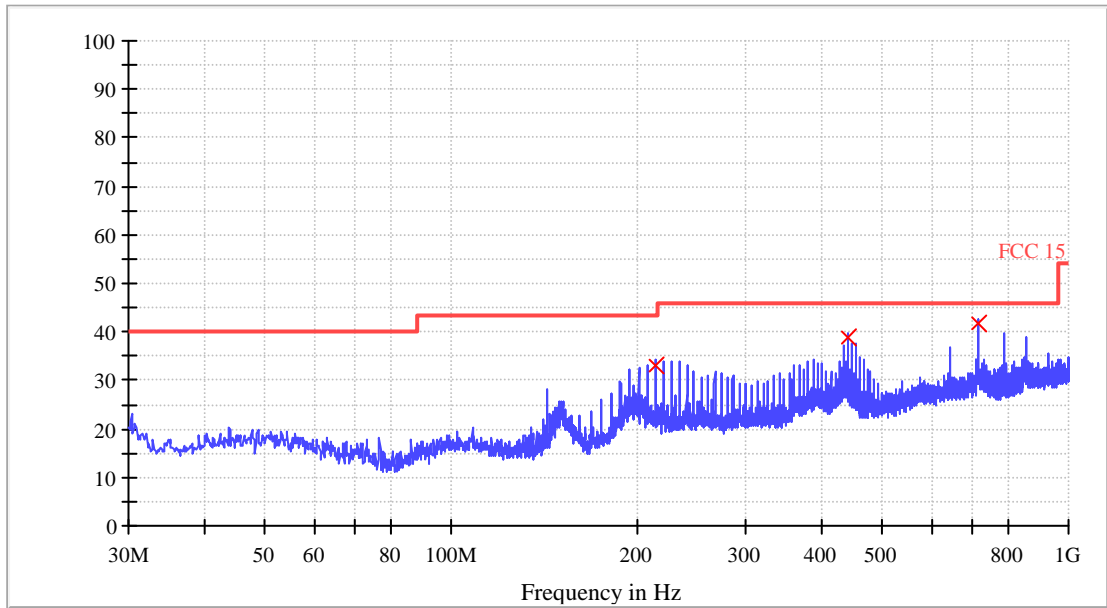

Quasi-peak measurement

Frequency (MHz)	Quasi Peak (dBμV/m)	Bandwidth (kHz)	Pol	Corr. (dB)	Margin - QPK (dB)	Limit - QPK (dBμV/m)
214.440000	33.1	120.000	H	13.1	10.4	43.5
438.840000	38.7	120.000	H	18.5	7.3	46.0
714.560000	41.7	120.000	H	23.2	4.3	46.0





1~25 GHz Radiated Emissions.

Polarization	Frequency (MHz)	PK Net at 3m (dB $\mu$ V/m)	AV Net at 3m (dB $\mu$ V/m)	Correction Factor (dB)	PK Limit at 3m (dB $\mu$ V/m)	PK Margin (dB)	AV Limit at 3m (dB $\mu$ V/m)	AV Margin (dB)
Horizontal	1218.000	44.7	/	-17.5	74.0	/	54.0	/
Horizontal	4874.000	59.3	47.8	-8.8	74.0	-14.7	54.0	-6.2
Horizontal	7754.000	35.0	/	-4.9	74.0	/	54.0	/
Vertical	1992.000	32.4	/	-13.8	74.0	/	54.0	/
Vertical	4878.000	44.5	/	-8.8	74.0	/	54.0	/
Vertical	7318.000	36.5	/	-4.9	74.0	/	54.0	/

Remark: When Peak emission level was below AV limit, the AV emission level did not be recorded.

The field strength is calculated by adding the Antenna Factor, Cable Factor & Preamplifier. The basic equation with a sample calculation is as follows:

Final Test Level = Receiver Reading + Antenna Factor + Cable Factor – Preamplifier Factor.

No any other emissions level which are attenuated less than 20dB below the limit.

Test at Channel 11 (2.462 GHz) in transmitting status

30 MHz~1 GHz Radiated Emissions .Quasi-Peak Measurement

**Vertical:**

Level (dBμV/m)

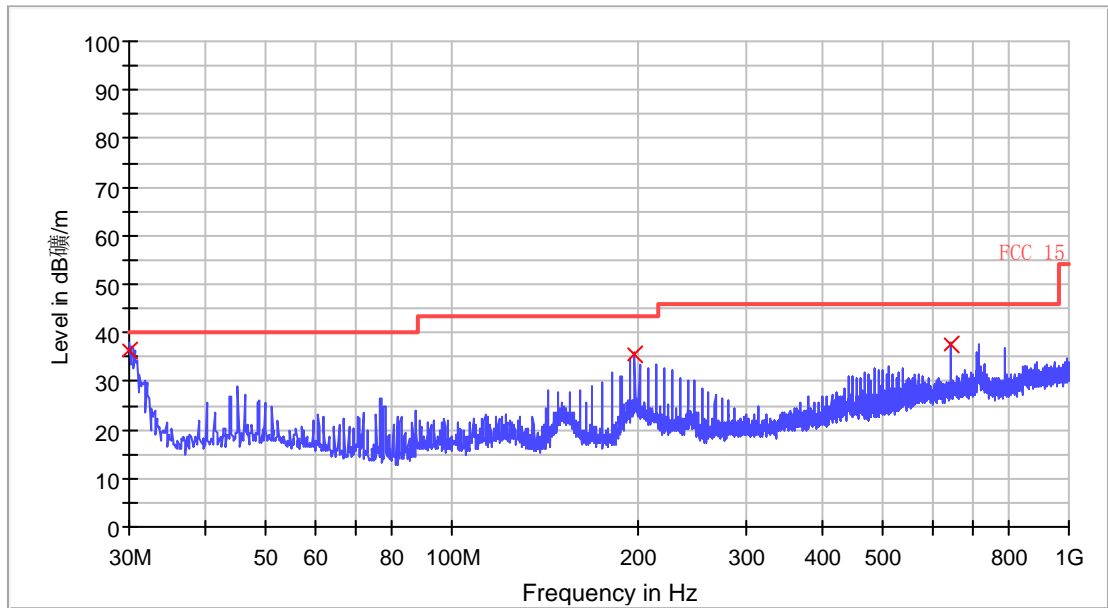

Quasi-peak measurement

Frequency (MHz)	Quasi Peak (dBμV/m)	Bandwidth (kHz)	Pol	Corr. (dB)	Margin - QPK (dB)	Limit - QPK (dBμV/m)
30.000000	36.4	120.000	V	11.2	3.6	40.0
197.920000	35.4	120.000	V	12.4	8.1	43.5
643.160000	37.5	120.000	V	22.4	8.5	46.0

**Horizontal:**  
 Level (dBμV/m)

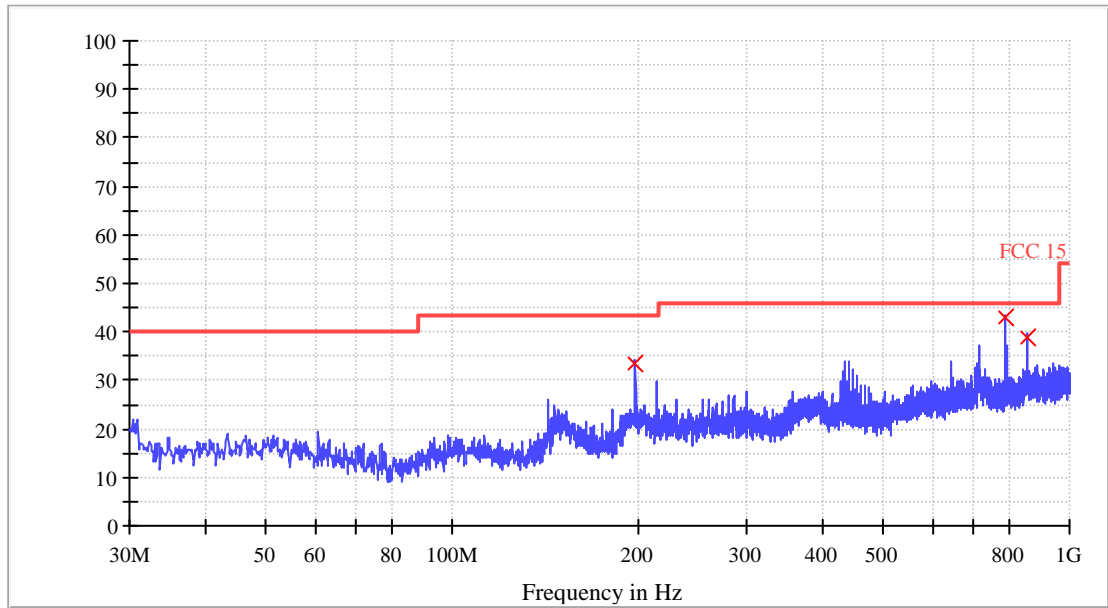

Quasi-peak measurement

Frequency (MHz)	Quasi Peak (dBμV/m)	Bandwidth (kHz)	Pol	Corr. (dB)	Margin - QPK (dB)	Limit - QPK (dBμV/m)
197.920000	33.6	120.000	H	12.4	9.9	43.5
786.120000	42.8	120.000	H	24.1	3.2	46.0
857.520000	39.0	120.000	H	25.1	7.0	46.0



Report No.: 170116067GZU-002  
Issued: 2017-10-19

1~25 GHz Radiated Emissions. Peak & Average Measurement

Polarization	Frequency (MHz)	PK Net at 3m (dB $\mu$ V/m)	AV Net at 3m (dB $\mu$ V/m)	Correction Factor (dB)	PK Limit at 3m (dB $\mu$ V/m)	PK Margin (dB)	AV Limit at 3m (dB $\mu$ V/m)	AV Margin (dB)
Horizontal	1230.000	42.1	/	-17.5	74.0	/	54.0	/
Horizontal	2496.000	55.1	47.0	-12.6	74.0	-18.9	54.0	-7.0
Horizontal	4923.000	60.5	48.7	-8.8	74.0	-13.5	54.0	-5.3
Horizontal	7698.000	34.7	/	-4.6	74.0	/	54.0	/
Vertical	1230.000	32.0	/	-17.5	74.0	/	54.0	/
Vertical	2496.000	50.8	/	-12.6	74.0	/	54.0	/
Vertical	4920.000	54.0	46.2	-8.8	74.0	-20.0	54.0	-7.8
Vertical	5305.000	43.1	/	-8.4	74.0	/	54.0	/

Remark: When Peak emission level was below AV limit, the AV emission level did not be recorded.

The field strength is calculated by adding the Antenna Factor. Cable Factor & Preamplifier. The basic equation with a sample calculation is as follows:

Final Test Level = Receiver Reading + Antenna Factor + Cable Factor – Preamplifier Factor.

No any other emissions level which are attenuated less than 20dB below the limit.

Band Edge test Restricted Bands  
 Horizontal

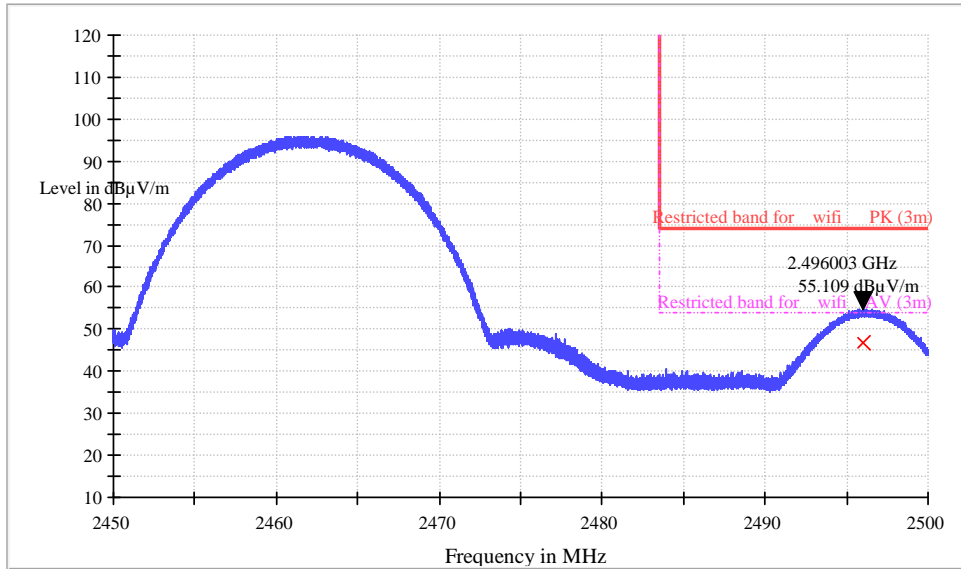

Polarization	Frequency (MHz)	PK Net at 3m (dBµV/m)	AV Net at 3m (dBµV/m)	Correction Factor (dB)	PK Limit at 3m (dBµV/m)	PK Margin (dB)	AV Limit at 3m (dBµV/m)	AV Margin (dB)
Horizontal	2496.003	55.1	47.0	-12.6	74.0	-18.9	54.0	-7.0

Vertical

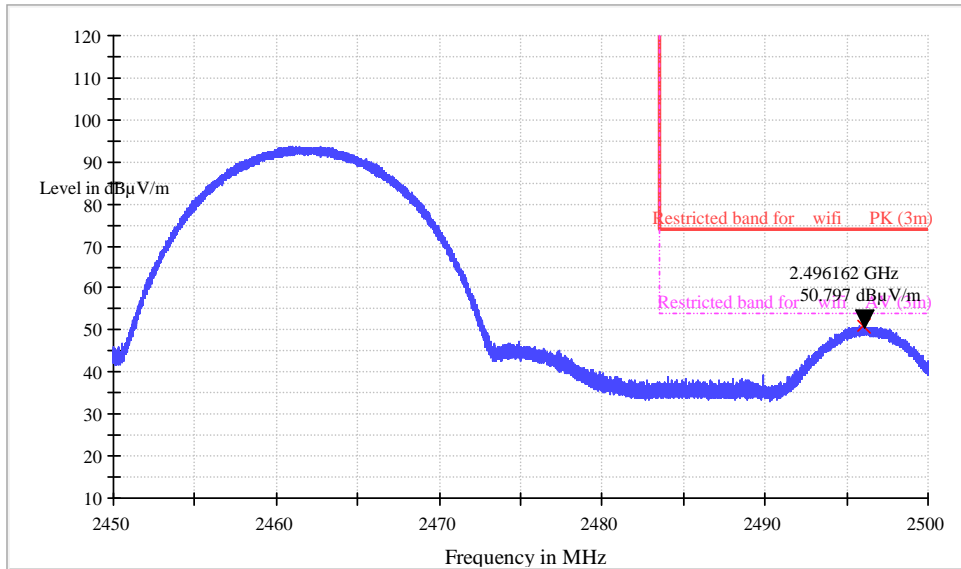

Polarization	Frequency (MHz)	PK Net at 3m (dBµV/m)	AV Net at 3m (dBµV/m)	Correction Factor (dB)	PK Limit at 3m (dBµV/m)	PK Margin (dB)	AV Limit at 3m (dBµV/m)	AV Margin (dB)
Vertical	2496.162	50.8	/	-12.6	74.0	/	54.0	/

Remark: When Peak emission level was below AV limit, the AV emission level did not be recorded.

802.11g mode with 54Mbps data rate

9 kHz~30 MHz Field Strength of Unwanted Emissions. Quasi-Peak Measurement

The measurements with active loop antenna were greater than 20dB below the limit, so the test data were not recorded in the test report.

Test at Channel 1 (2.412 GHz) in transmitting status

30 MHz~1 Radiated Emissions .Quasi-Peak Measurement

**Vertical:**

Level (dBμV/m)

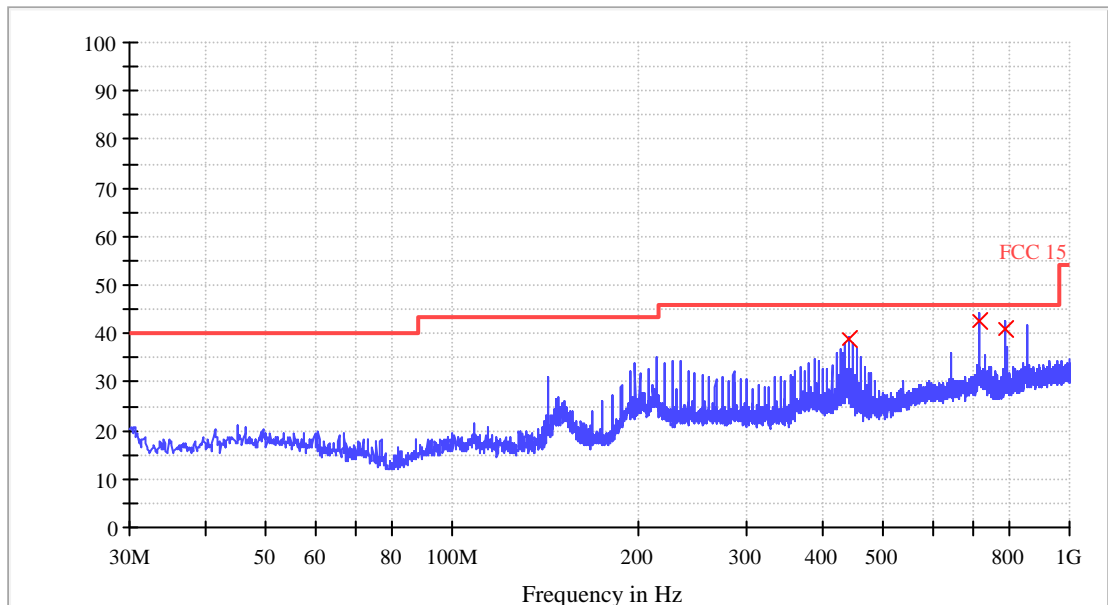

Quasi-peak measurement

Frequency (MHz)	Quasi Peak (dBμV/m)	Bandwidth (kHz)	Pol	Corr. (dB)	Margin - QPK (dB)	Limit - QPK (dBμV/m)
438.840000	39.0	120.000	H	18.5	7.0	46.0
714.560000	42.6	120.000	H	23.2	3.4	46.0
786.120000	40.7	120.000	H	24.1	5.3	46.0

**Horizontal:**  
 Level (dB $\mu$ V/m)

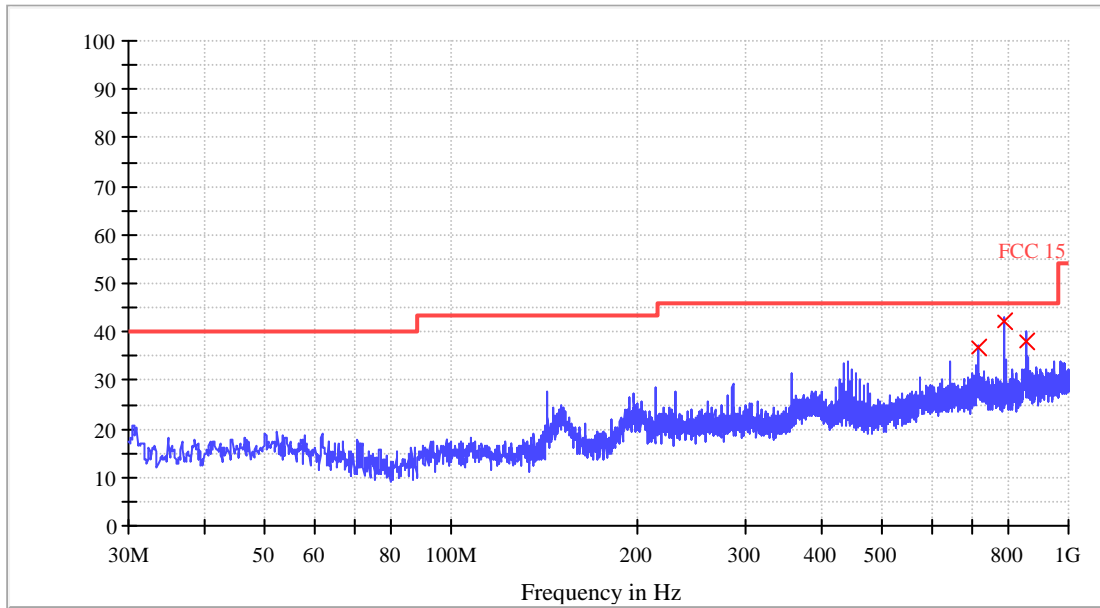

Quasi-peak measurement

Frequency (MHz)	Quasi Peak (dB $\mu$ V/m)	Bandwidth (kHz)	Pol	Corr. (dB)	Margin - QPK (dB)	Limit - QPK (dB $\mu$ V/m)
714.560000	36.7	120.000	H	23.2	9.3	46.0
786.000000	42.1	120.000	H	24.1	3.9	46.0
857.520000	38.0	120.000	H	25.1	8.0	46.0





Report No.: 170116067GZU-002  
 Issued: 2017-10-19

1~25 GHz Radiated Emissions. Peak & Average Measurement

Polarization	Frequency (MHz)	PK Net at 3m (dBµV/m)	AV Net at 3m (dBµV/m)	Correction Factor (dB)	PK Limit at 3m (dBµV/m)	PK Margin (dB)	AV Limit at 3m (dBµV/m)	AV Margin (dB)
Horizontal	1202.000	38.2	/	-17.5	74.0	/	54.0	/
Horizontal	2389.000	65.6	44.1	-7.0	74.0	-8.4	54.0	-9.9
Horizontal	4826.000	51.2	/	-8.8	74.0	/	54.0	/
Horizontal	10648.000	40.4	/	-8.4	74.0	/	54.0	/
Vertical	1202.000	33.9	/	-17.5	74.0	/	54.0	/
Vertical	2389.000	69.1	47.5	-7.0	74.0	-4.9	54.0	-6.5
Vertical	4826.000	39.4	/	-8.8	74.0	/	54.0	/
Vertical	6030.000	35.5	/	-6.2	74.0	/	54.0	/

Remark: When Peak emission level was below AV limit, the AV emission level did not be recorded.

The field strength is calculated by adding the Antenna Factor. Cable Factor & Preamplifier. The basic equation with a sample calculation is as follows:

Final Test Level = Receiver Reading + Antenna Factor + Cable Factor – Preamplifier Factor.

No any other emissions level which are attenuated less than 20dB below the limit.

Band Edge test Restricted Bands  
 Horizontal

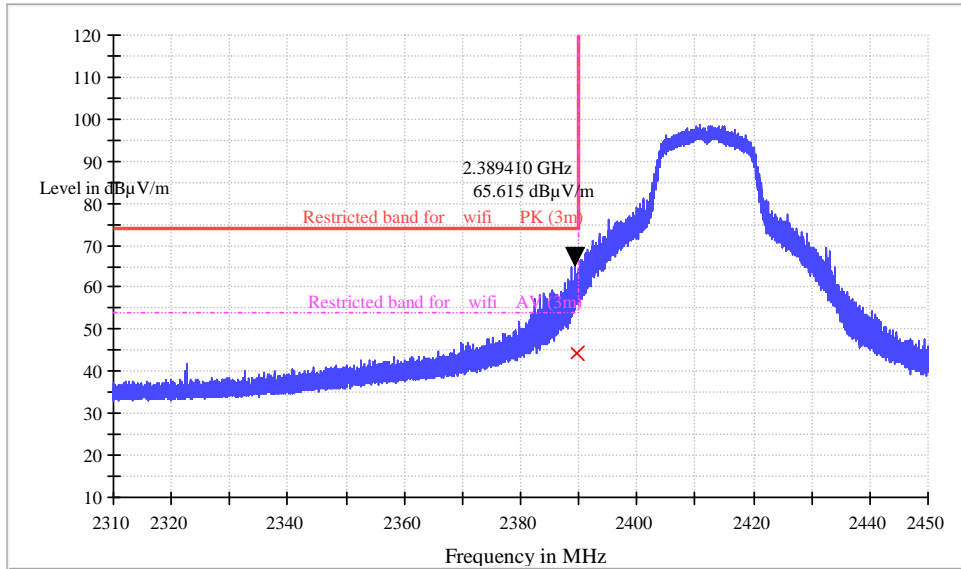

Polarization	Frequency (MHz)	PK Net at 3m (dBµV/m)	AV Net at 3m (dBµV/m)	Correction Factor (dB)	PK Limit at 3m (dBµV/m)	PK Margin (dB)	AV Limit at 3m (dBµV/m)	AV Margin (dB)
Horizontal	2389.410	65.6	44.1	-7.0	74.0	-8.4	54.0	-9.9

Vertical

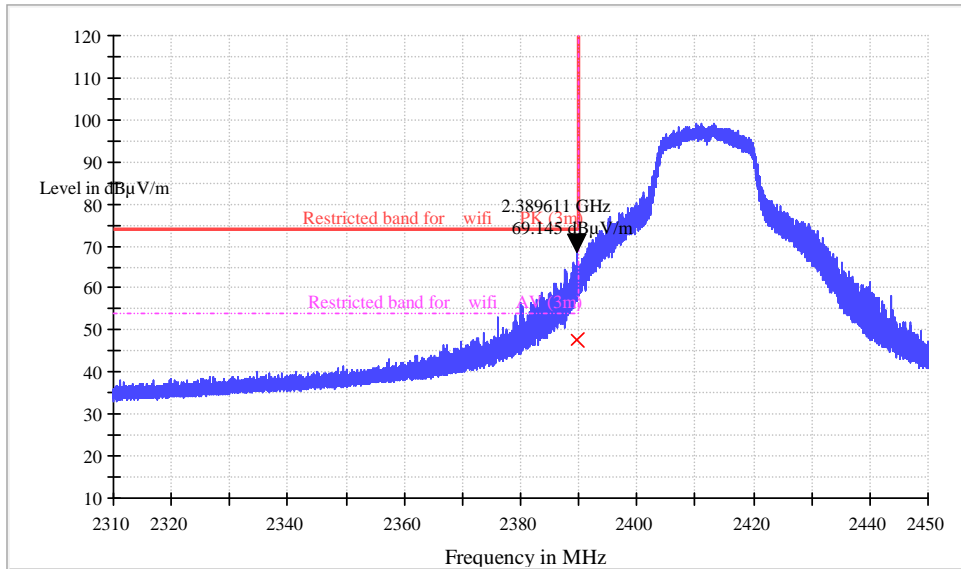

Polarization	Frequency (MHz)	PK Net at 3m (dBµV/m)	AV Net at 3m (dBµV/m)	Correction Factor (dB)	PK Limit at 3m (dBµV/m)	PK Margin (dB)	AV Limit at 3m (dBµV/m)	AV Margin (dB)
Vertical	2389.611	69.1	47.5	-7.0	74.0	-4.9	54.0	-6.5

Remark: When Peak emission level was below AV limit, the AV emission level did not be recorded.

Test at Channel 6 (2.437GHz) in transmitting status  
 30 MHz~1 GHz Radiated Emissions .Quasi-Peak Measurement

**Vertical:**

Level (dBμV/m)

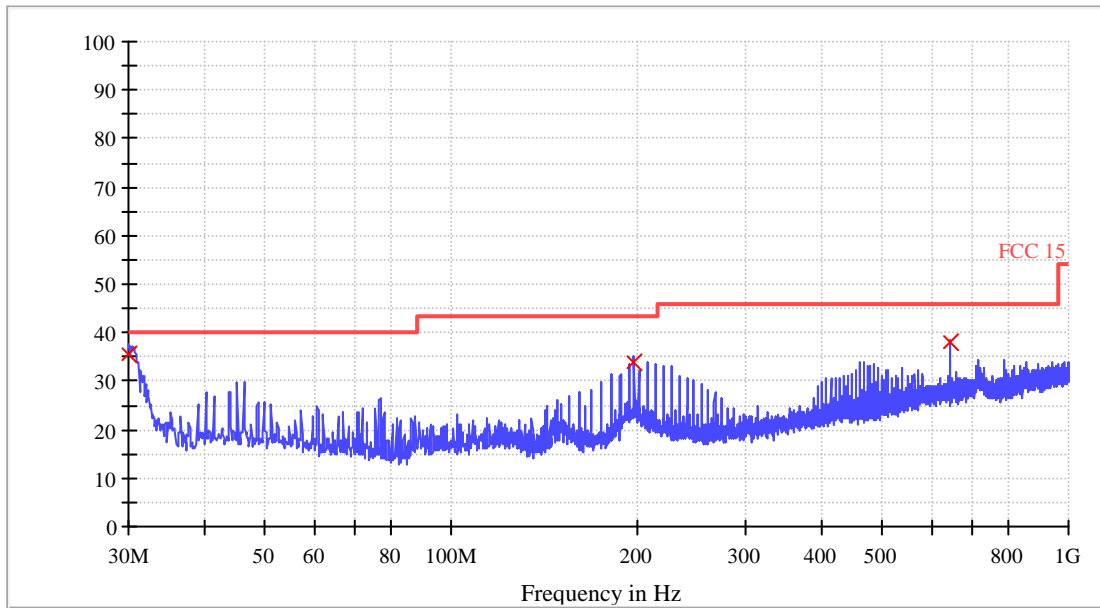

Quasi-peak measurement

Frequency (MHz)	Quasi Peak (dBμV/m)	Bandwidth (kHz)	Pol	Corr. (dB)	Margin - QPK (dB)	Limit - QPK (dBμV/m)
30.000000	35.5	120.000	V	11.2	4.5	40.0
197.920000	34.0	120.000	V	12.4	9.6	43.5
643.160000	38.0	120.000	V	22.4	8.1	46.0

**Horizontal:**  
 Level (dBμV/m)

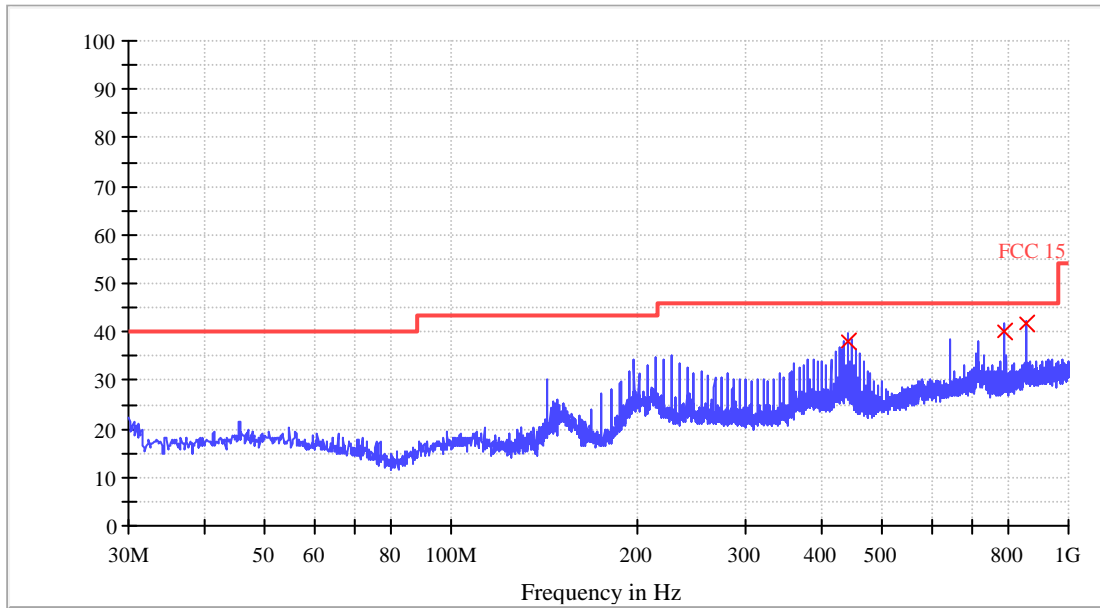

Quasi-peak measurement

Frequency (MHz)	Quasi Peak (dBμV/m)	Bandwidth (kHz)	Pol	Corr. (dB)	Margin - QPK (dB)	Limit - QPK (dBμV/m)
438.840000	37.9	120.000	H	18.5	8.1	46.0
786.120000	39.9	120.000	H	24.1	6.1	46.0
857.520000	41.6	120.000	H	25.1	4.4	46.0



Report No.: 170116067GZU-002  
Issued: 2017-10-19

1~25 GHz Radiated Emissions. Peak & Average Measurement

Polarization	Frequency (MHz)	PK Net at 3m (dB $\mu$ V/m)	AV Net at 3m (dB $\mu$ V/m)	Correction Factor (dB)	PK Limit at 3m (dB $\mu$ V/m)	PK Margin (dB)	AV Limit at 3m (dB $\mu$ V/m)	AV Margin (dB)
Horizontal	1217.000	34.7	/	-17.5	74.0	/	54.0	/
Horizontal	4871.000	53.2	43.0	-8.8	74.0	-20.8	54.0	-11.0
Vertical	1249.000	30.7	/	-17.4	74.0	/	54.0	/
Vertical	2108.000	30.2	/	-13.5	74.0	/	54.0	/
Vertical	4867.600	47.6	/	-4.9	74.0	/	54.0	/

Remark: When Peak emission level was below AV limit, the AV emission level did not be recorded.

The field strength is calculated by adding the Antenna Factor. Cable Factor & Preamplifier. The basic equation with a sample calculation is as follows:

Final Test Level = Receiver Reading + Antenna Factor + Cable Factor – Preamplifier Factor.

No any other emissions level which are attenuated less than 20dB below the limit.

Test at Channel 11 (2.462 GHz) in transmitting status  
 30 MHz~1 GHz Radiated Emissions .Quasi-Peak Measurement

**Vertical:**

Level (dBμV/m)

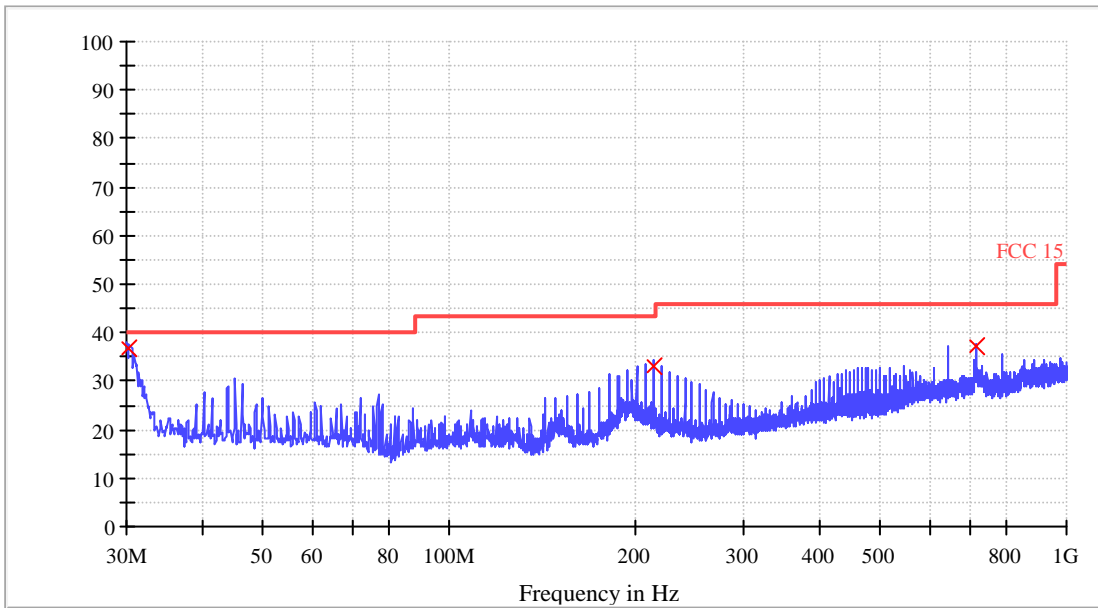

Quasi-peak measurement

Frequency (MHz)	Quasi Peak (dBμV/m)	Bandwidth (kHz)	Pol	Corr. (dB)	Margin - QPK (dB)	Limit - QPK (dBμV/m)
30.240000	36.6	120.000	V	11.2	3.4	40.0
214.440000	33.2	120.000	V	13.1	10.3	43.5
714.560000	37.2	120.000	V	23.2	8.8	46.0

**Horizontal:**  
 Level (dB $\mu$ V/m)

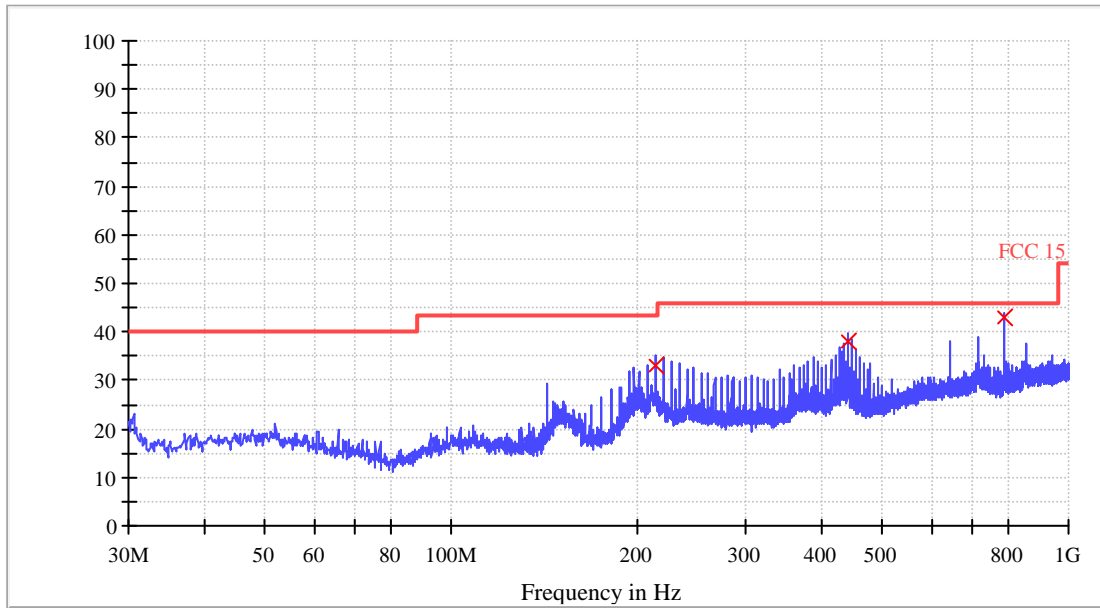

Quasi-peak measurement

Frequency (MHz)	Quasi Peak (dB $\mu$ V/m)	Bandwidth (kHz)	Pol	Corr. (dB)	Margin - QPK (dB)	Limit - QPK (dB $\mu$ V/m)
214.440000	33.2	120.000	H	13.1	10.3	43.5
438.840000	37.9	120.000	H	18.5	8.1	46.0
786.120000	43.1	120.000	H	24.1	2.9	46.0





1~25 GHz Radiated Emissions. Peak & Average Measurement

Polarization	Frequency (MHz)	PK Net at 3m (dB $\mu$ V/m)	AV Net at 3m (dB $\mu$ V/m)	Correction Factor (dB)	PK Limit at 3m (dB $\mu$ V/m)	PK Margin (dB)	AV Limit at 3m (dB $\mu$ V/m)	AV Margin (dB)
Horizontal	1230.000	37.7	/	-17.5	74.0	/	54.0	/
Horizontal	2483.600	67.0	46.1	-12.6	74.0	-7.0	54.0	-7.9
Horizontal	4920.000	57.1	46.2	-8.8	74.0	-16.9	54.0	-7.8
Horizontal	5337.000	44.8	/	-4.6	74.0	/	54.0	/
Vertical	1247.000	29.7	/	-17.5	74.0	/	54.0	/
Vertical	2483.700	64.2	44.7	-12.6	74.0	-9.8	54.0	-9.3
Vertical	4920.000	48.1	/	-8.8	74.0	-25.9	54.0	/

Remark: When Peak emission level was below AV limit, the AV emission level did not be recorded.

The field strength is calculated by adding the Antenna Factor. Cable Factor & Preamplifier. The basic equation with a sample calculation is as follows:

Final Test Level = Receiver Reading + Antenna Factor + Cable Factor – Preamplifier Factor.

No any other emissions level which are attenuated less than 20dB below the limit.

Band Edge test Restricted Bands  
 Horizontal

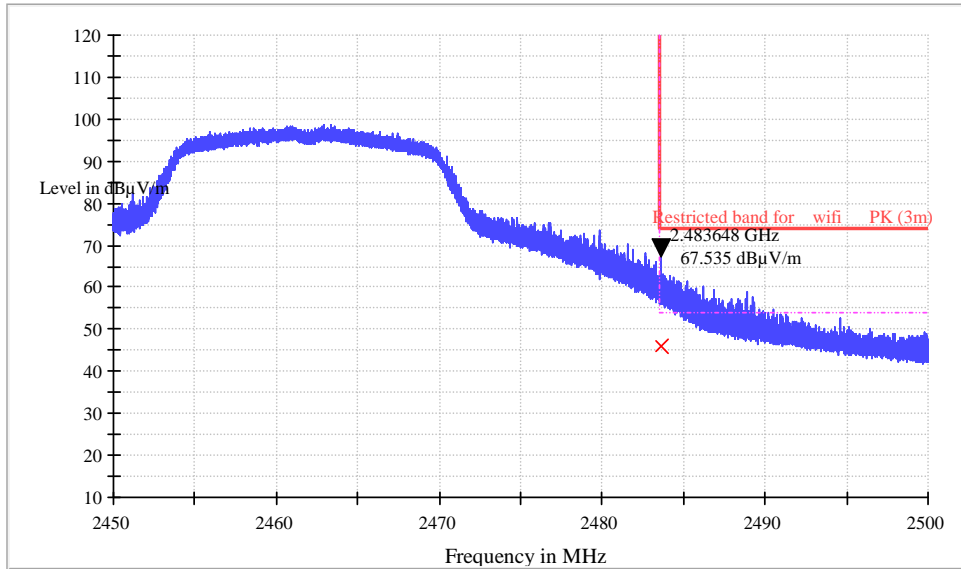

Polarization	Frequency (MHz)	PK Net at 3m (dBµV/m)	AV Net at 3m (dBµV/m)	Correction Factor (dB)	PK Limit at 3m (dBµV/m)	PK Margin (dB)	AV Limit at 3m (dBµV/m)	AV Margin (dB)
Horizontal	2483.648	67.0	46.1	-12.6	74.0	-7.0	54.0	-7.9

Vertical

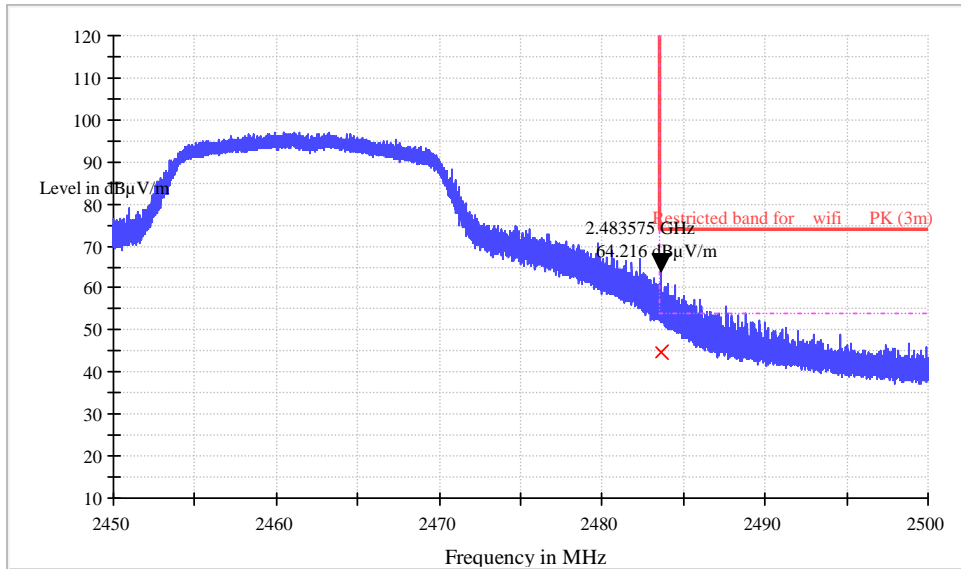

Polarization	Frequency (MHz)	PK Net at 3m (dBµV/m)	AV Net at 3m (dBµV/m)	Correction Factor (dB)	PK Limit at 3m (dBµV/m)	PK Margin (dB)	AV Limit at 3m (dBµV/m)	AV Margin (dB)
Vertical	2483.575	64.2	44.7	-12.6	74.0	-9.8	54.0	-9.3

Remark: When Peak emission level was below AV limit, the AV emission level did not be recorded.

802.11n (HT20) mode with 72.2Mbps data rate

9 kHz~30 MHz Field Strength of Unwanted Emissions. Quasi-Peak Measurement

The measurements with active loop antenna were greater than 20dB below the limit, so the test data were not recorded in the test report.

Test at Channel 1 (2.412 GHz) in transmitting status

30 MHz~1 GHz Radiated Emissions .Quasi-Peak Measurement

**Vertical:**

Level (dBμV/m)

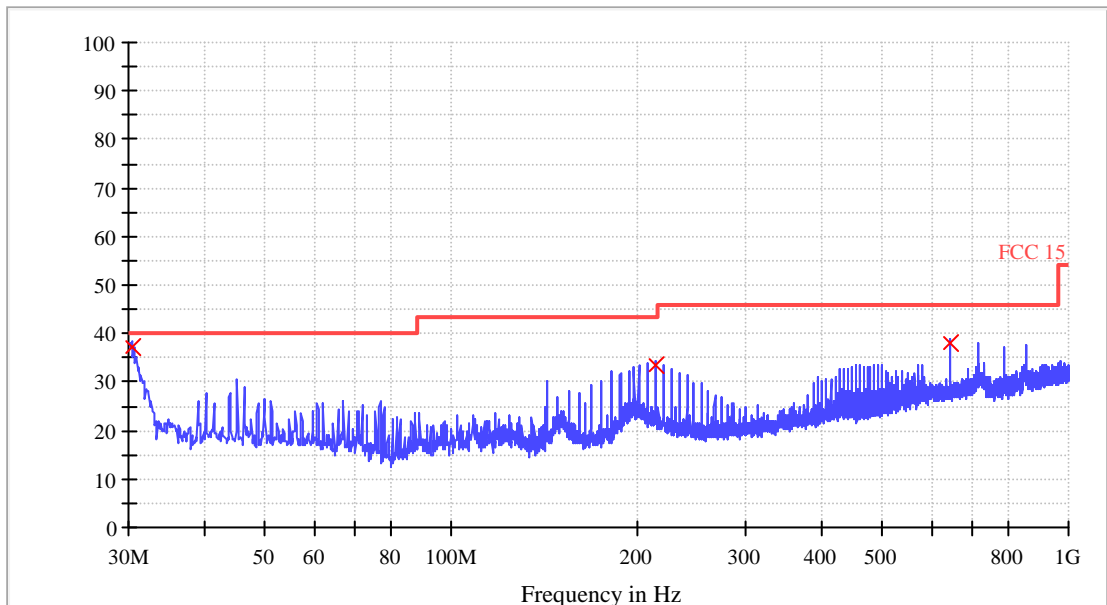

Quasi-peak measurement

Frequency (MHz)	Quasi Peak (dBμV/m)	Bandwidth (kHz)	Pol	Corr. (dB)	Margin - QPK (dB)	Limit - QPK (dBμV/m)
30.360000	37.1	120.000	V	11.2	2.9	40.0
214.440000	33.3	120.000	V	13.1	10.2	43.5
643.160000	38.1	120.000	V	22.4	7.9	46.0

**Horizontal:**  
 Level (dBμV/m)

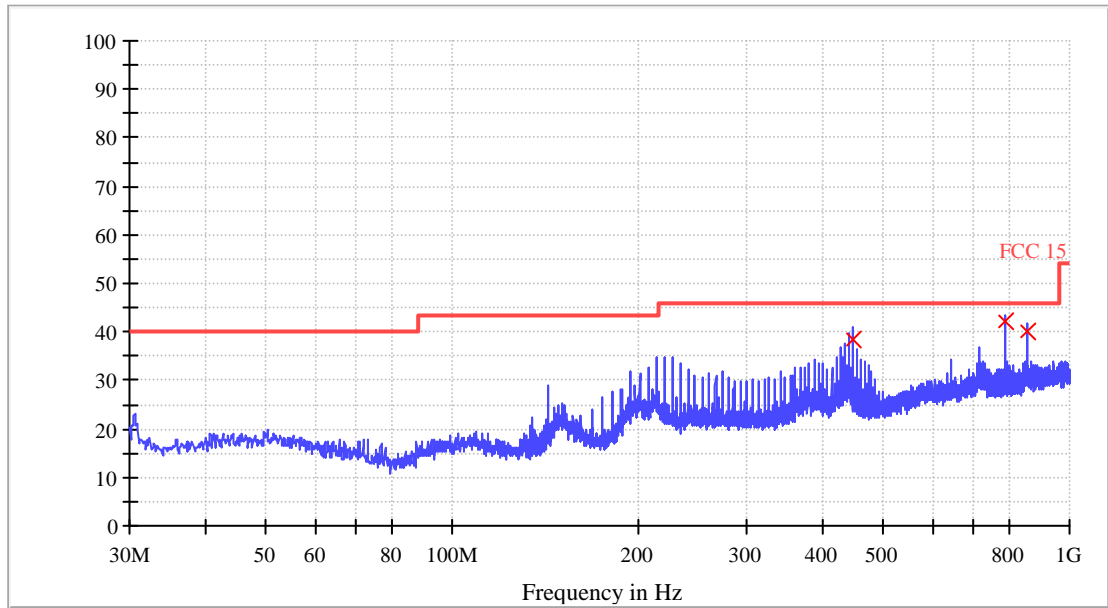

Quasi-peak measurement

Frequency (MHz)	Quasi Peak (dBμV/m)	Bandwidth (kHz)	Pol	Corr. (dB)	Margin - QPK (dB)	Limit - QPK (dBμV/m)
445.520000	38.6	120.000	H	18.6	7.5	46.0
786.120000	42.2	120.000	H	24.1	3.8	46.0
857.520000	40.2	120.000	H	25.1	5.8	46.0



1~25 GHz Radiated Emissions. Peak & Average Measurement

Polarization	Frequency (MHz)	PK Net at 3m (dBµV/m)	AV Net at 3m (dBµV/m)	Correction Factor (dB)	PK Limit at 3m (dBµV/m)	PK Margin (dB)	AV Limit at 3m (dBµV/m)	AV Margin (dB)
Horizontal	1203.000	40.6	/	-17.5	74.0	/	54.0	/
Horizontal	2389.000	52.1	/	-7.0	74.0	/	54.0	/
Horizontal	4824.000	45.4	/	-8.8	74.0	/	54.0	/
Vertical	1203.000	34.1	/	-17.5	74.0	/	54.0	/
Vertical	2389.000	43.7	/	-7.0	74.0	/	54.0	/
Vertical	4817.000	44.6	/	-8.8	74.0	/	54.0	/
Vertical	5309.000	48.2	/	-6.2	74.0	/	54.0	/

Remark: When Peak emission level was below AV limit, the AV emission level did not be recorded.

The field strength is calculated by adding the Antenna Factor. Cable Factor & Preamplifier. The basic equation with a sample calculation is as follows:

Final Test Level = Receiver Reading + Antenna Factor + Cable Factor – Preamplifier Factor.

No any other emissions level which are attenuated less than 20dB below the limit.

Band Edge test Restricted Bands  
 Horizontal

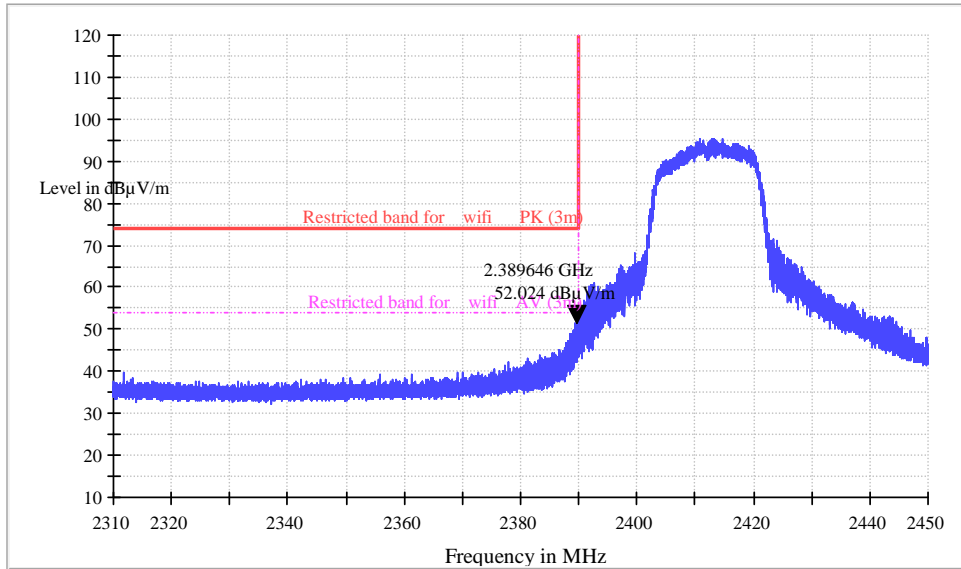

Polarization	Frequency (MHz)	PK Net at 3m (dBµV/m)	AV Net at 3m (dBµV/m)	Correction Factor (dB)	PK Limit at 3m (dBµV/m)	PK Margin (dB)	AV Limit at 3m (dBµV/m)	AV Margin (dB)
Horizontal	2389.646	52.1	/	-7.0	74.0	/	54.0	/

Vertical

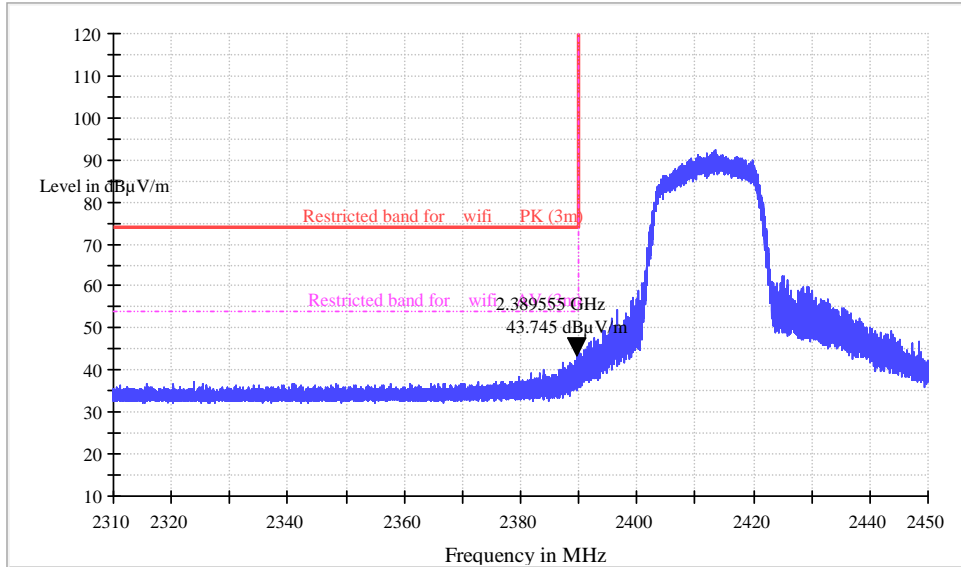

Polarization	Frequency (MHz)	PK Net at 3m (dBµV/m)	AV Net at 3m (dBµV/m)	Correction Factor (dB)	PK Limit at 3m (dBµV/m)	PK Margin (dB)	AV Limit at 3m (dBµV/m)	AV Margin (dB)
Vertical	2389.555	43.7	/	-7.0	74.0	/	54.0	/

Remark: When Peak emission level was below AV limit, the AV emission level did not be recorded.



Test at Channel 6 (2.437 GHz) in transmitting status  
 30 MHz~1 GHz Radiated Emissions .Quasi-Peak Measurement

**Vertical:**

Level (dBμV/m)

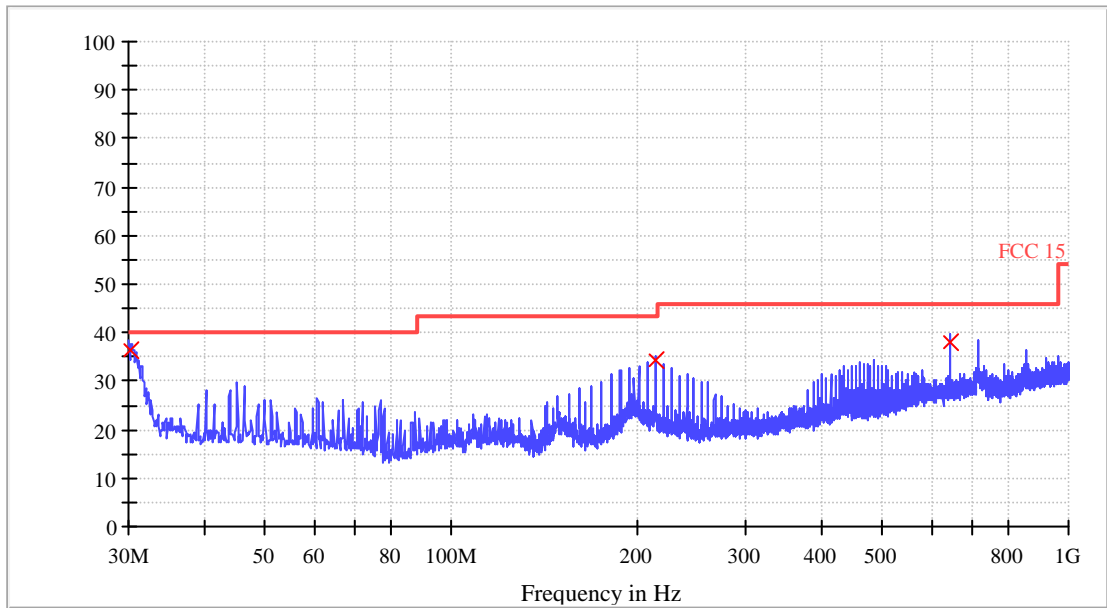

Quasi-peak measurement

Frequency (MHz)	Quasi Peak (dBμV/m)	Bandwidth (kHz)	Pol	Corr. (dB)	Margin - QPK (dB)	Limit - QPK (dBμV/m)
30.240000	36.5	120.000	V	11.2	3.5	40.0
214.440000	34.3	120.000	V	13.1	9.2	43.5
643.160000	38.1	120.000	V	22.4	7.9	46.0

**Horizontal:**  
 Level (dBμV/m)

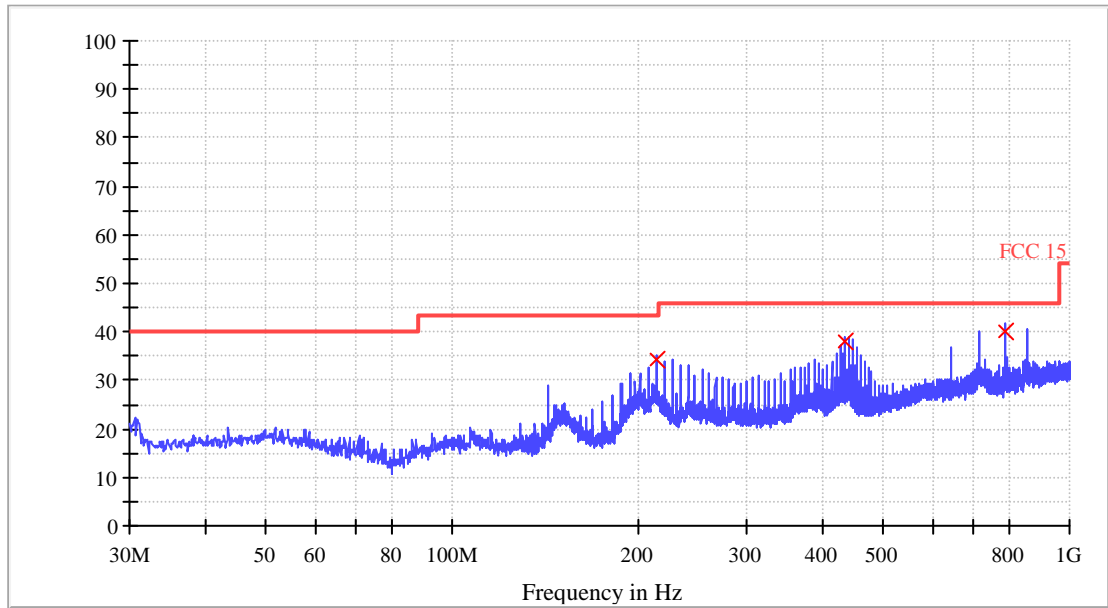

Quasi-peak measurement

Frequency (MHz)	Quasi Peak (dBμV/m)	Bandwidth (kHz)	Pol	Corr. (dB)	Margin - QPK (dB)	Limit - QPK (dBμV/m)
214.280000	34.2	120.000	H	13.1	9.3	43.5
432.320000	38.2	120.000	H	18.3	7.8	46.0
786.120000	40.3	120.000	H	24.1	5.8	46.0



Report No.: 170116067GZU-002  
Issued: 2017-10-19

1~25 GHz Radiated Emissions. Peak & Average Measurement

Polarization	Frequency (MHz)	PK Net at 3m (dB $\mu$ V/m)	AV Net at 3m (dB $\mu$ V/m)	Correction Factor (dB)	PK Limit at 3m (dB $\mu$ V/m)	PK Margin (dB)	AV Limit at 3m (dB $\mu$ V/m)	AV Margin (dB)
Horizontal	1218.000	37.7	/	-17.5	74.0	/	54.0	/
Horizontal	4871.000	52.9	/	-8.8	74.0	/	54.0	/
Horizontal	10643.000	44.4	/	-4.7	74.0	/	54.0	/
Vertical	1496.800	31.8	/	-16.5	74.0	/	54.0	/
Vertical	4873.000	48.8	/	-8.8	74.0	/	54.0	/
Vertical	5308.000	40.2	/	-8.4	74.0	/	54.0	/

Remark: When Peak emission level was below AV limit, the AV emission level did not be recorded.

The field strength is calculated by adding the Antenna Factor. Cable Factor & Preamplifier. The basic equation with a sample calculation is as follows:

Final Test Level = Receiver Reading + Antenna Factor + Cable Factor – Preamplifier Factor.

No any other emissions level which are attenuated less than 20dB below the limit.

Test at Channel 11 (2.462 GHz) in transmitting status

30 MHz~1 GHz Radiated Emissions .Quasi-Peak Measurement

**Vertical:**

Level (dBμV/m)

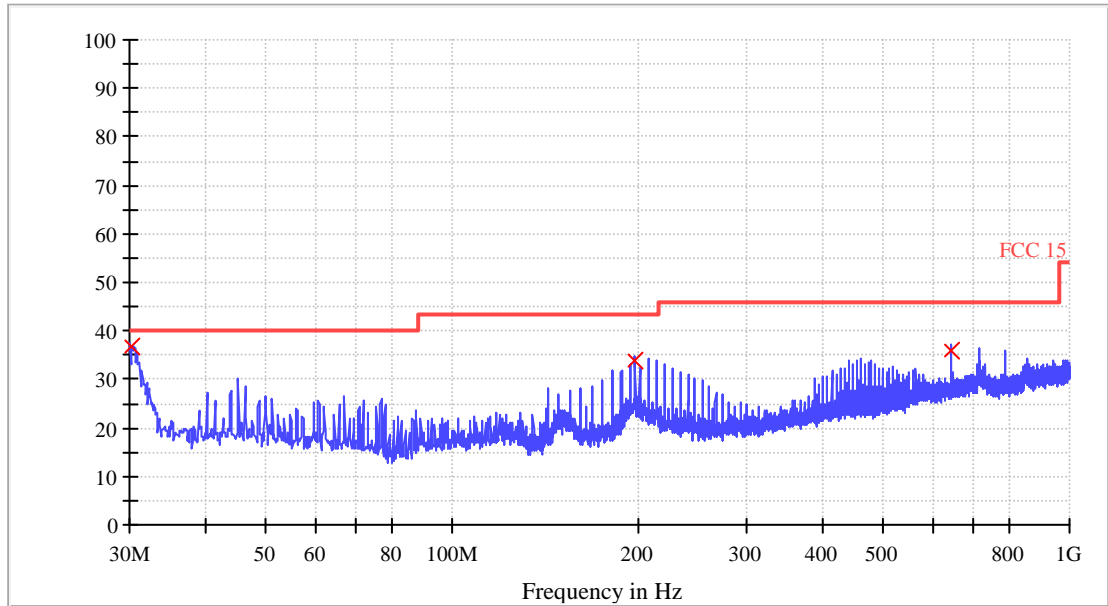

Quasi-peak measurement

Frequency (MHz)	Quasi Peak (dBμV/m)	Bandwidth (kHz)	Pol	Corr. (dB)	Margin - QPK (dB)	Limit - QPK (dBμV/m)
30.240000	36.6	120.000	V	11.2	3.4	40.0
197.920000	33.7	120.000	V	12.4	9.8	43.5
643.160000	36.0	120.000	V	22.4	10.0	46.0

**Horizontal:**  
 Level (dB $\mu$ V/m)

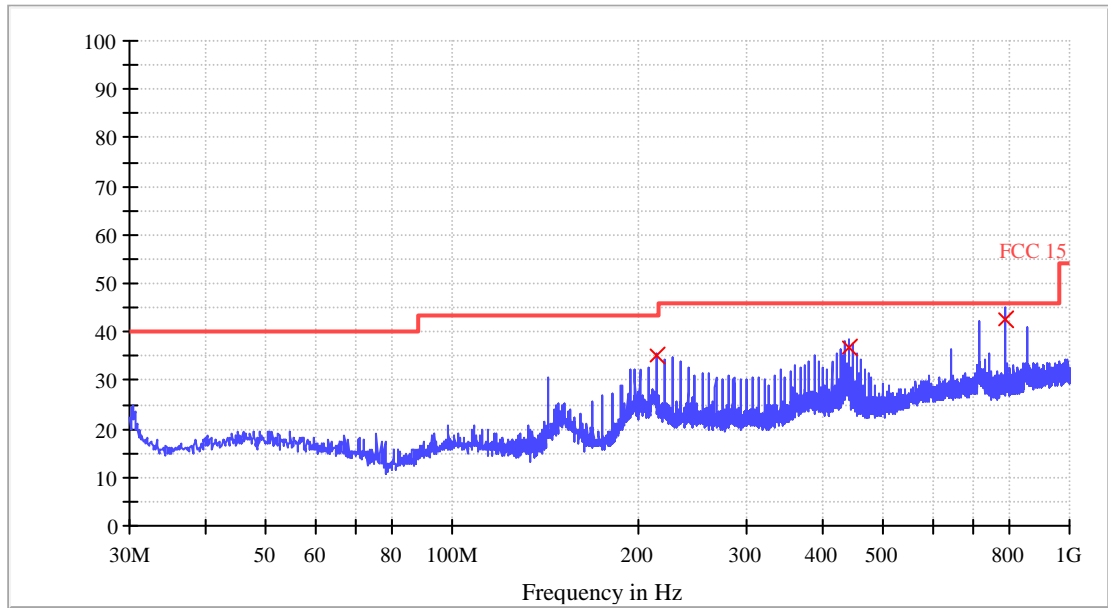

Quasi-peak measurement

Frequency (MHz)	Quasi Peak (dB $\mu$ V/m)	Bandwidth (kHz)	Pol	Corr. (dB)	Margin - QPK (dB)	Limit - QPK (dB $\mu$ V/m)
214.440000	35.0	120.000	H	13.1	8.5	43.5
438.840000	36.8	120.000	H	18.5	9.2	46.0
786.000000	42.8	120.000	H	24.1	3.2	46.0

1~25 GHz Radiated Emissions. Peak & Average Measurement

**PK Measurement:**

Polarization	Frequency (MHz)	PK Net at 3m (dBμV/m)	AV Net at 3m (dBμV/m)	Correction Factor (dB)	PK Limit at 3m (dBμV/m)	PK Margin (dB)	AV Limit at 3m (dBμV/m)	AV Margin (dB)
Horizontal	1231.000	39.3	/	-17.5	74.0	/	54.0	/
Horizontal	2483.500	65.0	47.9	-12.6	74.0	-9.0	54.0	-6.1
Horizontal	4925.000	57.6	43.4	-8.8	74.0	-16.4	54.0	-10.6
Horizontal	5322.000	47.7	/	-4.6	74.0	/	54.0	/
Vertical	1230.000	32.0	/	-17.5	74.0	/	54.0	/
Vertical	2483.500	62.7	44.2	-12.6	74.0	-11.3	54.0	-9.8
Vertical	4918.000	51.1	/	-8.8	74.0	/	54.0	/
Vertical	5310.000	46.0	/	-8.4	74.0	/	54.0	/

Remark: When Peak emission level was below AV limit, the AV emission level did not be recorded.

The field strength is calculated by adding the Antenna Factor. Cable Factor & Preamplifier. The basic equation with a sample calculation is as follows:

Final Test Level = Receiver Reading + Antenna Factor + Cable Factor – Preamplifier Factor.

No any other emissions level which are attenuated less than 20dB below the limit.



Report No.: 170116067GZU-002  
 Issued: 2017-10-19

Band Edge test Restricted Bands  
 Horizontal

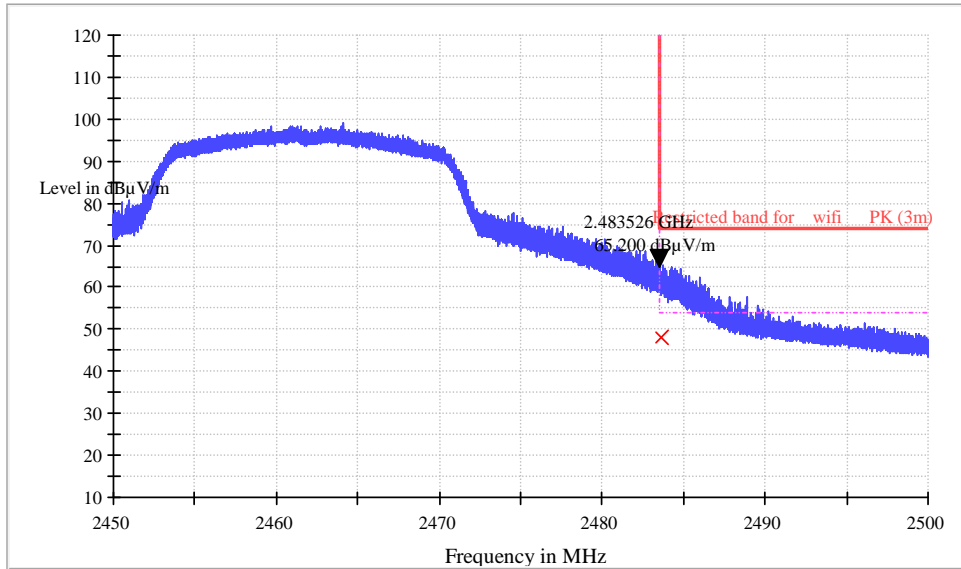

Polarization	Frequency (MHz)	PK Net at 3m (dBµV/m)	AV Net at 3m (dBµV/m)	Correction Factor (dB)	PK Limit at 3m (dBµV/m)	PK Margin (dB)	AV Limit at 3m (dBµV/m)	AV Margin (dB)
Horizontal	2483.526	65.0	47.9	-12.6	74.0	-9.0	54.0	-6.1

Vertical

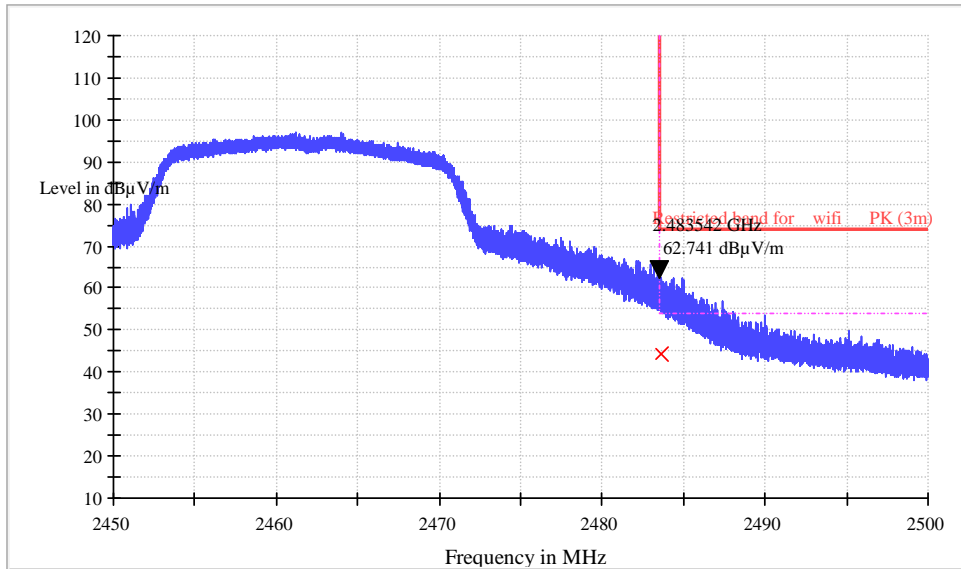

Polarization	Frequency (MHz)	PK Net at 3m (dBµV/m)	AV Net at 3m (dBµV/m)	Correction Factor (dB)	PK Limit at 3m (dBµV/m)	PK Margin (dB)	AV Limit at 3m (dBµV/m)	AV Margin (dB)
Vertical	2483.542	62.7	44.2	-12.6	74.0	-11.3	54.0	-9.8

Remark: When Peak emission level was below AV limit, the AV emission level did not be recorded.



802.11n (HT40) mode with 150Mbps data rate

9 kHz~30 MHz Field Strength of Unwanted Emissions. Quasi-Peak Measurement

The measurements with active loop antenna were greater than 20dB below the limit, so the test data were not recorded in the test report.

Test at Channel 3 (2.422 GHz) in transmitting status

30 MHz~1 GHz Radiated Emissions .Quasi-Peak Measurement

**Vertical:**

Level (dB $\mu$ V/m)

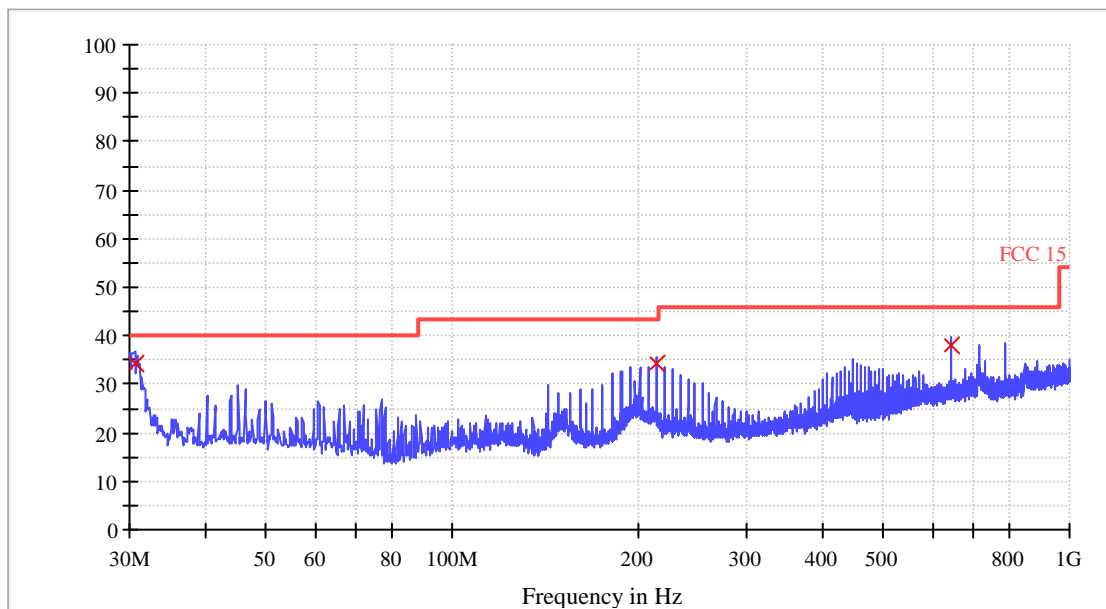

Quasi-peak measurement

Frequency (MHz)	Quasi Peak (dB $\mu$ V/m)	Bandwidth (kHz)	Pol	Corr. (dB)	Margin - QPK (dB)	Limit - QPK (dB $\mu$ V/m)
30.600000	34.5	120.000	V	11.2	5.5	40.0
214.440000	34.4	120.000	V	13.1	9.1	43.5
643.160000	38.1	120.000	V	22.4	7.9	46.0

**Horizontal:**  
 Level (dBμV/m)

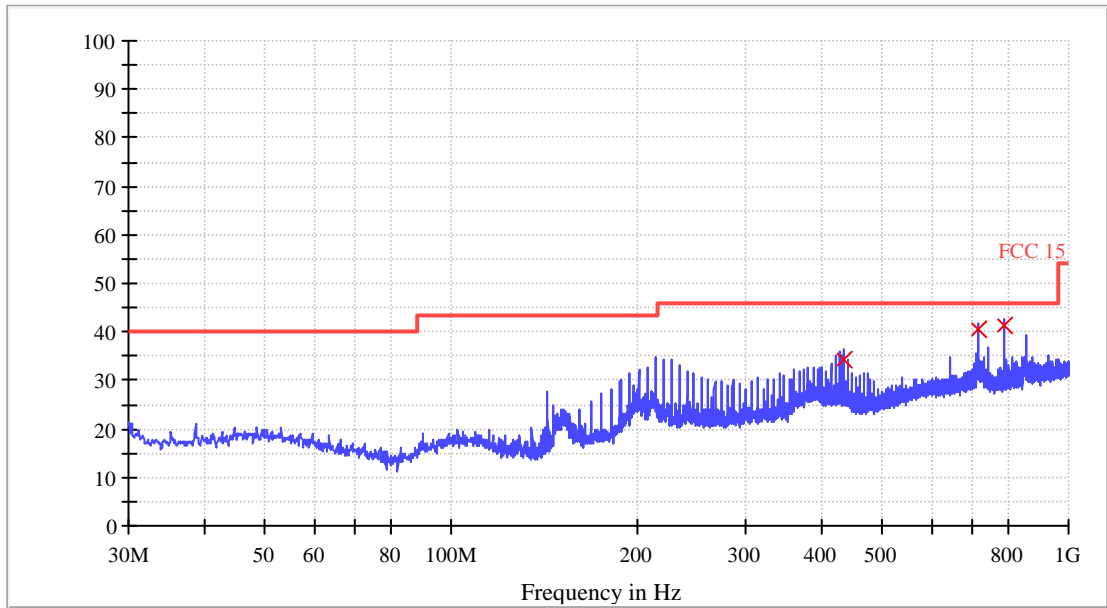

Quasi-peak measurement

Frequency (MHz)	Quasi Peak (dBμV/m)	Bandwidth (kHz)	Pol	Corr. (dB)	Margin - QPK (dB)	Limit - QPK (dBμV/m)
432.320000	34.2	120.000	H	18.3	11.8	46.0
714.560000	40.3	120.000	H	23.2	5.7	46.0
786.120000	41.3	120.000	H	24.1	4.8	46.0



1~25 GHz Radiated Emissions. Peak & Average Measurement

Polarization	Frequency (MHz)	PK Net at 3m (dB $\mu$ V/m)	AV Net at 3m (dB $\mu$ V/m)	Correction Factor (dB)	PK Limit at 3m (dB $\mu$ V/m)	PK Margin (dB)	AV Limit at 3m (dB $\mu$ V/m)	AV Margin (dB)
Horizontal	1204.000	38.8	/	-17.5	74.0	/	54.0	/
Horizontal	2387.000	60.4	42.8	-7.0	74.0	-13.6	54.0	-11.2
Horizontal	4844.000	47.7	/	-8.8	74.0	/	54.0	/
Horizontal	5308.000	51.4	/	-8.4	74.0	/	54.0	/
Vertical	1196.000	32.3	/	-17.5	74.0	/	54.0	/
Vertical	2389.800	47.6	/	-7.0	74.0	/	54.0	/
Vertical	4851.000	47.1	/	-8.8	74.0	/	54.0	/
Vertical	7252.000	38.8	/	-6.2	74.0	/	54.0	/

Remark: When Peak emission level was below AV limit, the AV emission level did not be recorded.

The field strength is calculated by adding the Antenna Factor. Cable Factor & Preamplifier. The basic equation with a sample calculation is as follows:

Final Test Level = Receiver Reading + Antenna Factor + Cable Factor – Preamplifier Factor.

No any other emissions level which are attenuated less than 20dB below the limit.

Band Edge test Restricted Bands  
 Horizontal

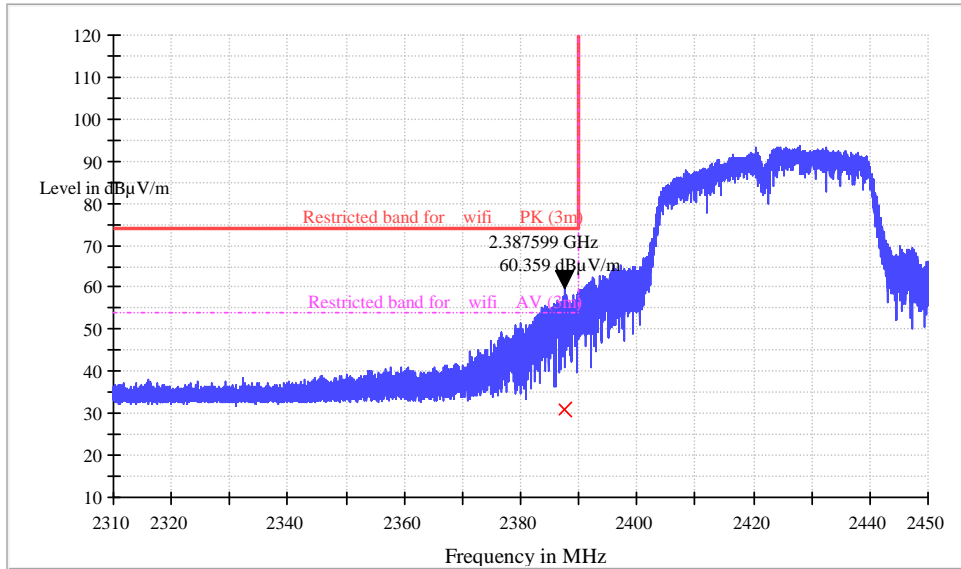

Polarization	Frequency (MHz)	PK Net at 3m (dBµV/m)	AV Net at 3m (dBµV/m)	Correction Factor (dB)	PK Limit at 3m (dBµV/m)	PK Margin (dB)	AV Limit at 3m (dBµV/m)	AV Margin (dB)
Horizontal	2387.599	60.4	42.8	-7.0	74.0	-13.6	54.0	-11.2

Vertical

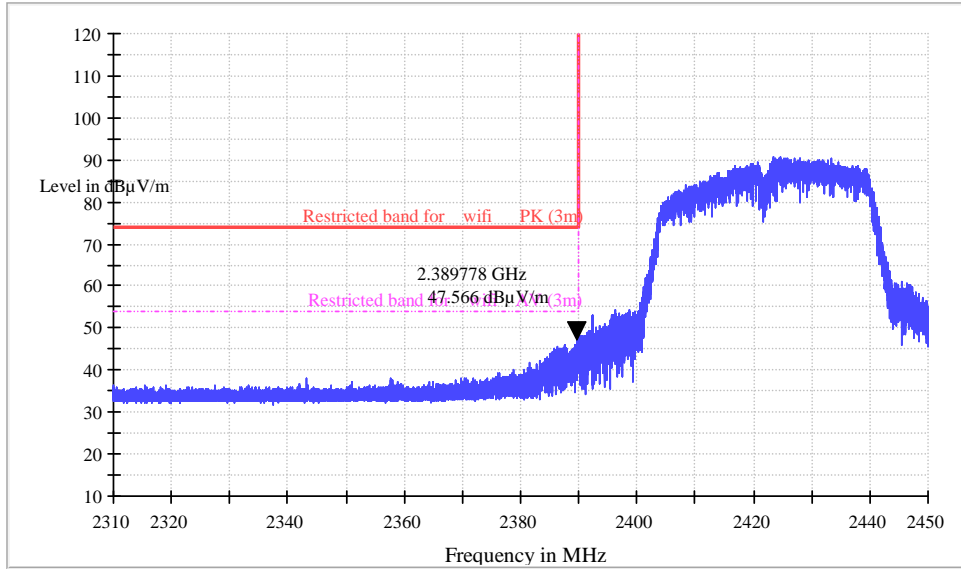

Polarization	Frequency (MHz)	PK Net at 3m (dBµV/m)	AV Net at 3m (dBµV/m)	Correction Factor (dB)	PK Limit at 3m (dBµV/m)	PK Margin (dB)	AV Limit at 3m (dBµV/m)	AV Margin (dB)
Vertical	2389.778	47.6	/	-7.0	74.0	/	54.0	/

Remark: When Peak emission level was below AV limit, the AV emission level did not be recorded.

Test at Channel 6 (2.437 GHz) in transmitting status  
 30 MHz~1 GHz Radiated Emissions .Quasi-Peak Measurement

**Vertical:**

Level (dBμV/m)

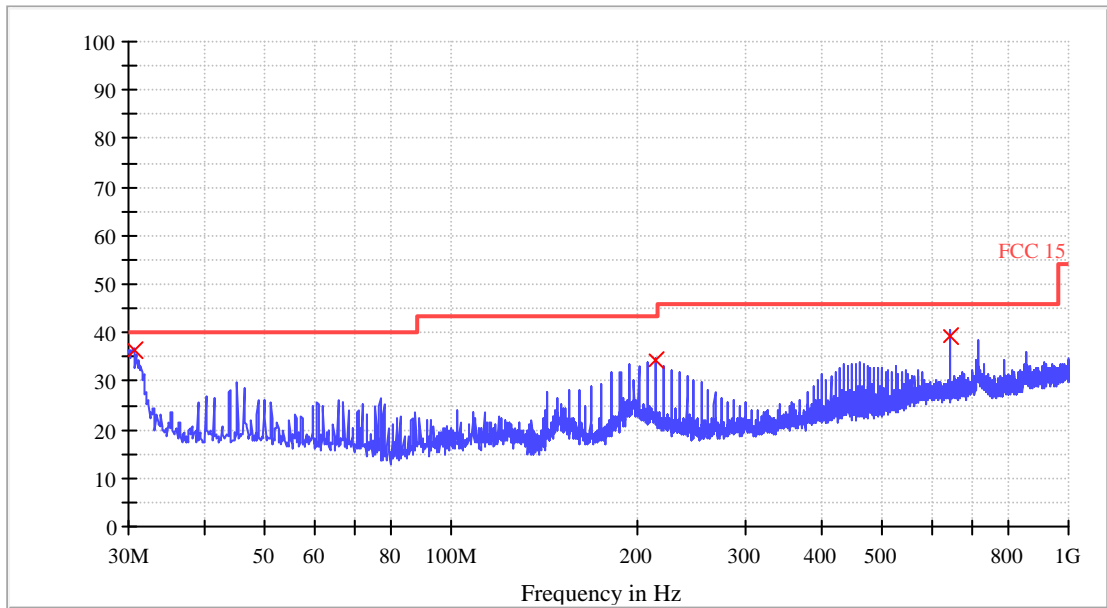

Quasi-peak measurement

Frequency (MHz)	Quasi Peak (dBμV/m)	Bandwidth (kHz)	Pol	Corr. (dB)	Margin - QPK (dB)	Limit - QPK (dBμV/m)
30.600000	36.3	120.000	V	11.2	3.7	40.0
214.440000	34.4	120.000	V	13.1	9.1	43.5
643.160000	39.2	120.000	V	22.4	6.8	46.0

**Horizontal:**  
 Level (dBμV/m)

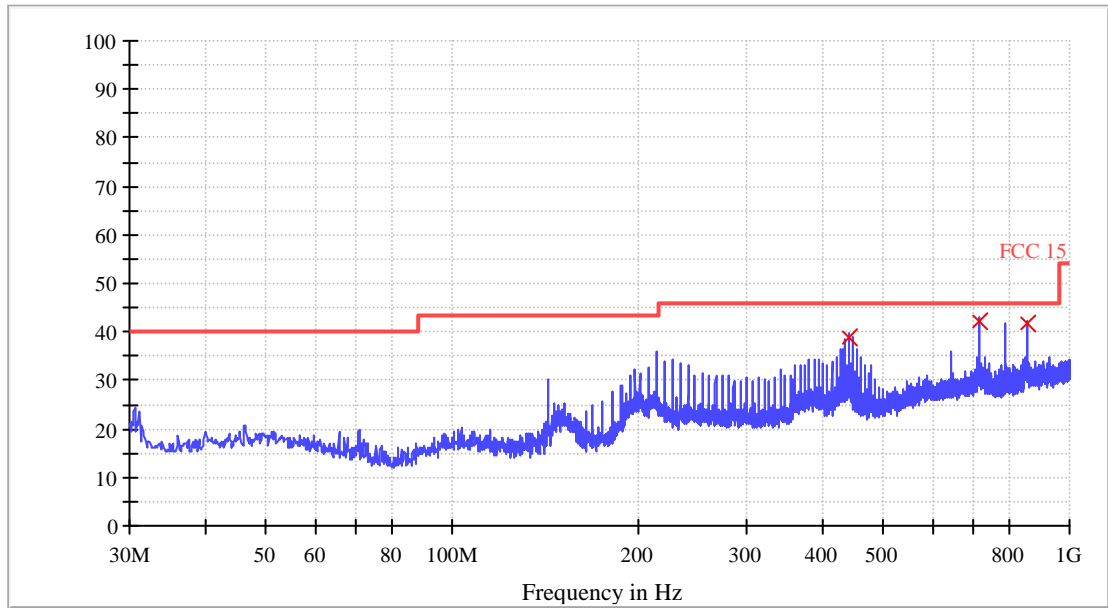

Quasi-peak measurement

Frequency (MHz)	Quasi Peak (dBμV/m)	Bandwidth (kHz)	Pol	Corr. (dB)	Margin - QPK (dB)	Limit - QPK (dBμV/m)
438.840000	38.8	120.000	H	18.5	7.2	46.0
714.560000	42.1	120.000	H	23.2	3.9	46.0
857.520000	41.6	120.000	H	25.1	4.4	46.0



Report No.: 170116067GZU-002  
Issued: 2017-10-19

1~25 GHz Radiated Emissions. Peak & Average Measurement

Polarization	Frequency (MHz)	PK Net at 3m (dBμV/m)	AV Net at 3m (dBμV/m)	Correction Factor (dB)	PK Limit at 3m (dBμV/m)	PK Margin (dB)	AV Limit at 3m (dBμV/m)	AV Margin (dB)
Horizontal	1218.000	36.9	/	-17.5	74.0	/	54.0	/
Horizontal	4872.800	49.0	/	-8.8	74.0	/	54.0	/
Horizontal	7706.000	35.0	/	-4.9	74.0	/	54.0	/
Vertical	1724.000	32.6	/	-15.3	74.0	/	54.0	/
Vertical	4866.000	47.4	/	-8.8	74.0	/	54.0	/
Vertical	10636.000	45.4	/	-4.9	74.0	/	54.0	/

Remark: When Peak emission level was below AV limit, the AV emission level did not be recorded.

The field strength is calculated by adding the Antenna Factor. Cable Factor & Preamplifier. The basic equation with a sample calculation is as follows:

Final Test Level = Receiver Reading + Antenna Factor + Cable Factor – Preamplifier Factor.

No any other emissions level which are attenuated less than 20dB below the limit.



Test at Channel 11 (2.452 GHz) in transmitting status

30 MHz~1 GHz Radiated Emissions .Quasi-Peak Measurement

**Vertical:**

Level (dB $\mu$ V/m)

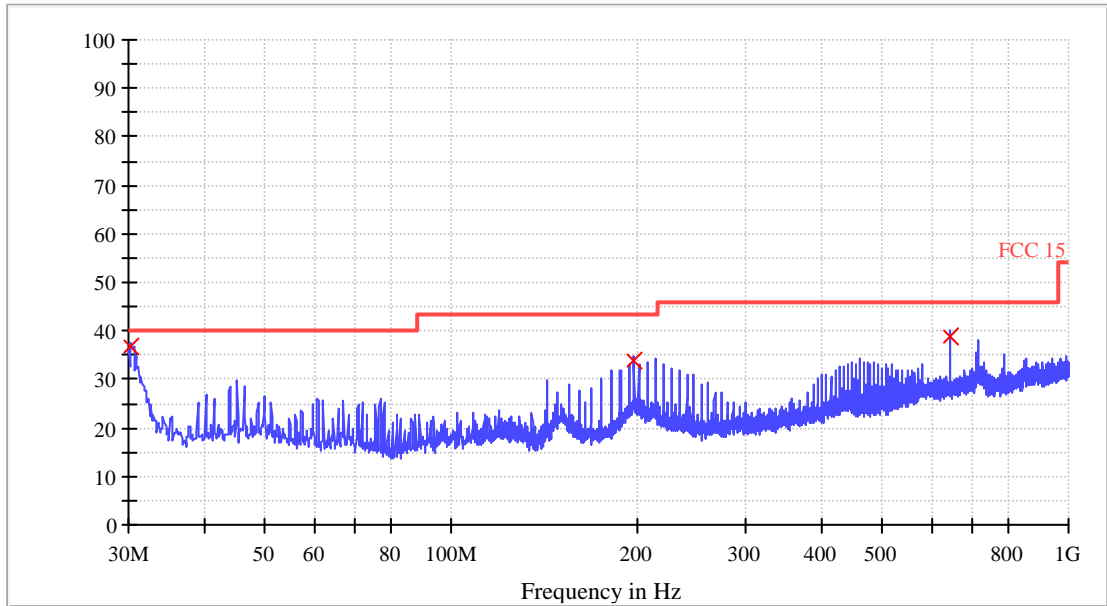

Quasi-peak measurement

Frequency (MHz)	Quasi Peak (dB $\mu$ V/m)	Bandwidth (kHz)	Pol	Corr. (dB)	Margin - QPK (dB)	Limit - QPK (dB $\mu$ V/m)
30.240000	36.8	120.000	V	11.2	3.2	40.0
197.920000	34.1	120.000	V	12.4	9.5	43.5
643.160000	39.0	120.000	V	22.4	7.0	46.0

**Horizontal:**  
 Level (dBμV/m)

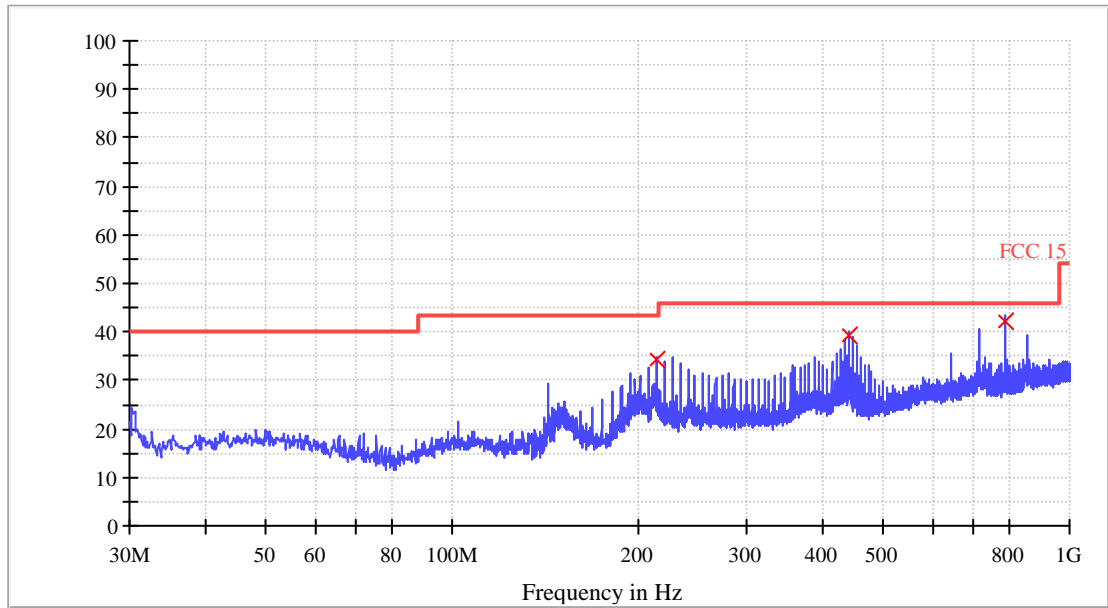

Quasi-peak measurement

Frequency (MHz)	Quasi Peak (dBμV/m)	Bandwidth (kHz)	Pol	Corr. (dB)	Margin - QPK (dB)	Limit - QPK (dBμV/m)
214.440000	34.2	120.000	H	13.1	9.3	43.5
438.840000	39.2	120.000	H	18.5	6.8	46.0
786.120000	42.2	120.000	H	24.1	3.8	46.0



Report No.: 170116067GZU-002  
Issued: 2017-10-19

1~25 GHz Radiated Emissions. Peak & Average Measurement

Polarization	Frequency (MHz)	PK Net at 3m (dBμV/m)	AV Net at 3m (dBμV/m)	Correction Factor (dB)	PK Limit at 3m (dBμV/m)	PK Margin (dB)	AV Limit at 3m (dBμV/m)	AV Margin (dB)
Horizontal	1222.400	37.2	/	-17.5	74.0	/	54.0	/
Horizontal	2484.000	56.8	43.6	-12.6	74.0	-17.2	54.0	-10.4
Horizontal	4905.600	56.2	46.0	-8.8	74.0	-17.8	54.0	-8.0
Vertical	1499.400	32.9	/	-17.5	74.0	/	54.0	/
Vertical	2484.100	65.7	45.1	-12.6	74.0	-8.3	54.0	-8.9
Vertical	4895.100	50.7	/	-8.8	74.0	/	54.0	/
Vertical	7346.800	37.4	/	-6.1	74.0	/	54.0	/

Remark: When Peak emission level was below AV limit, the AV emission level did not be recorded.

The field strength is calculated by adding the Antenna Factor, Cable Factor & Preamplifier. The basic equation with a sample calculation is as follows:

Final Test Level = Receiver Reading + Antenna Factor + Cable Factor – Preamplifier Factor.

No any other emissions level which are attenuated less than 20dB below the limit.



Report No.: 170116067GZU-002  
 Issued: 2017-10-19

Band Edge test Restricted Bands  
 Horizontal

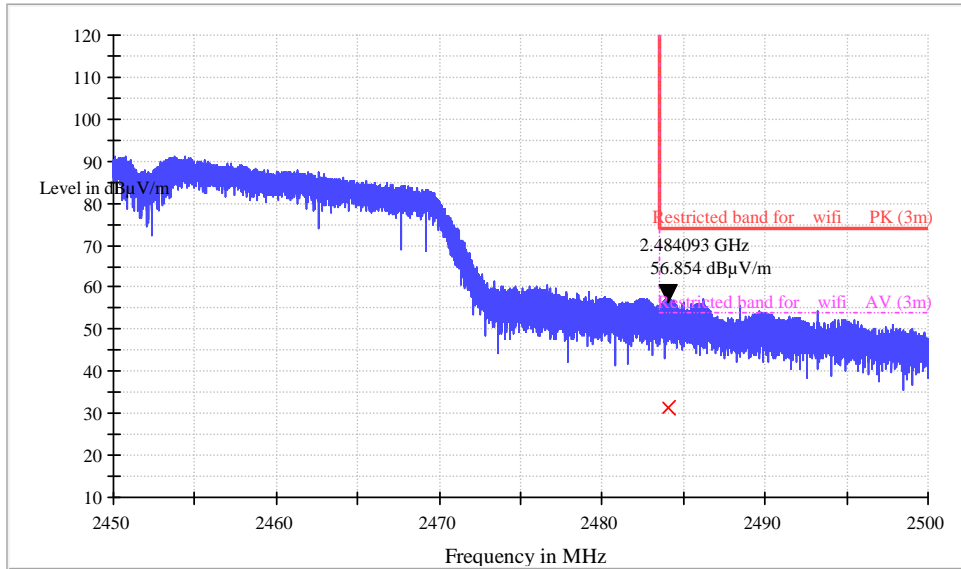

Polarization	Frequency (MHz)	PK Net at 3m (dBµV/m)	AV Net at 3m (dBµV/m)	Correction Factor (dB)	PK Limit at 3m (dBµV/m)	PK Margin (dB)	AV Limit at 3m (dBµV/m)	AV Margin (dB)
Horizontal	2484.093	56.8	43.6	-12.6	74.0	-17.2	54.0	-10.4

Vertical

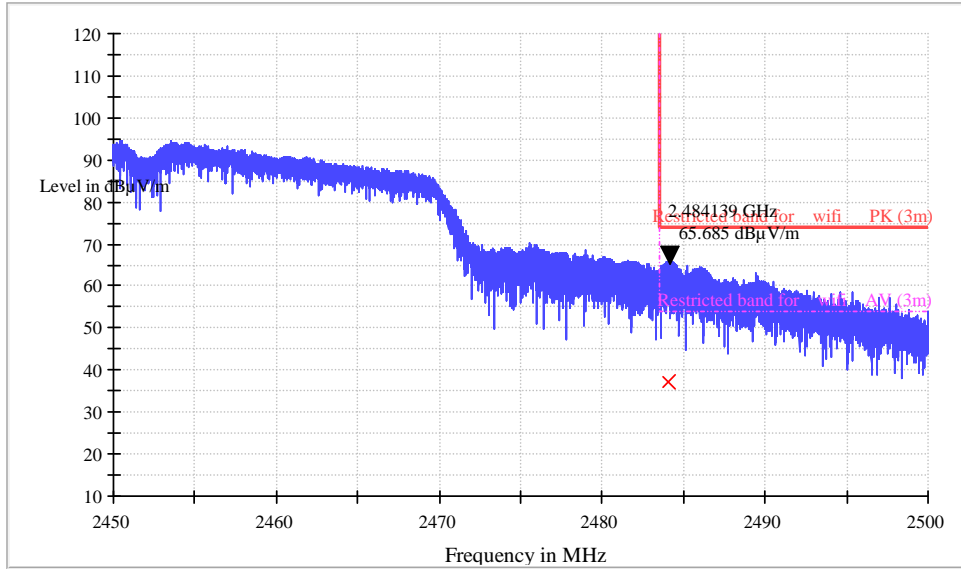

Polarization	Frequency (MHz)	PK Net at 3m (dBµV/m)	AV Net at 3m (dBµV/m)	Correction Factor (dB)	PK Limit at 3m (dBµV/m)	PK Margin (dB)	AV Limit at 3m (dBµV/m)	AV Margin (dB)
Vertical	2484.139	65.7	45.1	-12.6	74.0	-8.3	54.0	-8.9

Remark: When Peak emission level was below AV limit, the AV emission level did not be recorded.

#### 4.8 Conducted Emission Test

Test Configuration:

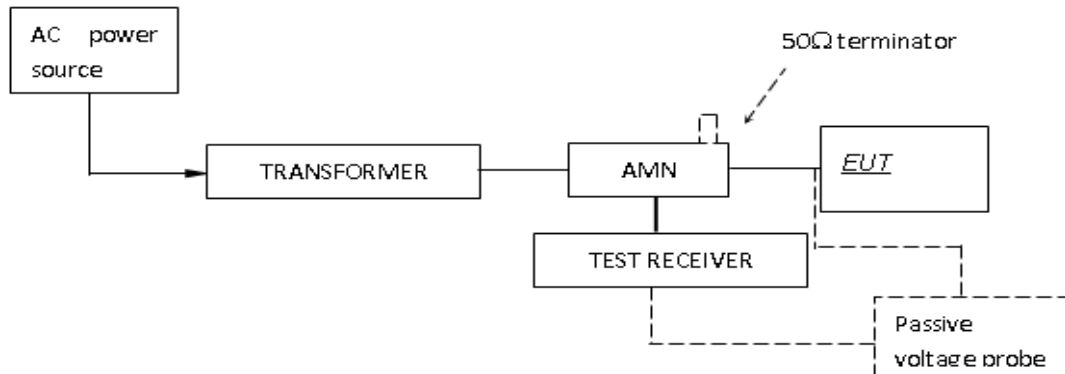

#### Test Setup and Procedure

Test was performed according to ANSI C63.10 Clause 6.2. The EUT was set to achieve the maximum emission level. The mains terminal disturbance voltage was measured with the EUT in a shielded room. The EUT was connected to AC power source through an Artificial Mains Network which provides a 50Ω linear impedance Artificial hand is used if appropriate (for handheld apparatus). The load/control terminal disturbance voltage was measured with passive voltage probe if appropriate.

The table-top EUT was placed on a 0.8m high non-metallic table above earthed ground plane (Ground Reference Plane). And for floor standing EUT, was placed on a 0.1m high non-metallic supported on GRP. The EUT keeps a distance of at least 0.8m from any other of the metallic surface. The Artificial Mains Network is situated at a distance of 0.8m from the EUT.

During the test, mains lead of EUT excess 0.8m was folded back and forth parallel to the lead so as to form a horizontal bundle with a length between 0.3m and 0.4m.

The bandwidth of test receiver was set at 9 kHz. The frequency range from 150 kHz to 30MHz was checked.

Test Data

At main terminal: Pass

Tested Wire: Live

Operation Mode: transmitting mode

EDIT PEAK LIST (Final Measurement Results)				
Trace1:	FCC15QP			
Trace2:	FCC15AV			
Trace3:	---			
TRACE	FREQUENCY	LEVEL dBuV		DELTA LIMIT dB
2 Average	614 kHz	13.60 L1		-32.39
1 Quasi Peak	2.106 MHz	35.77 L1		-20.22
2 Average	2.106 MHz	35.27 L1		-10.73
2 Average	2.406 MHz	32.91 L1		-13.08
1 Quasi Peak	2.45 MHz	32.86 L1		-23.13
1 Quasi Peak	29.49 MHz	40.77 L1		-19.22
2 Average	29.834 MHz	32.85 L1		-17.14

Tested Wire: Neutral

Operation Mode: transmitting mode

EDIT PEAK LIST (Final Measurement Results)				
Trace1:	FCC15QP			
Trace2:	FCC15AV			
Trace3:	---			
TRACE	FREQUENCY	LEVEL dBuV		DELTA LIMIT dB
2 Average	602 kHz	28.33 L1		-17.66
1 Quasi Peak	2.106 MHz	37.70 L1		-18.29
2 Average	2.106 MHz	34.87 L1		-11.12
1 Quasi Peak	2.406 MHz	36.19 L1		-19.80
2 Average	2.406 MHz	34.94 L1		-11.05
1 Quasi Peak	29.922 MHz	39.13 L1		-20.86
2 Average	29.922 MHz	31.02 L1		-18.97

Emission Curve

Tested Wire: Live

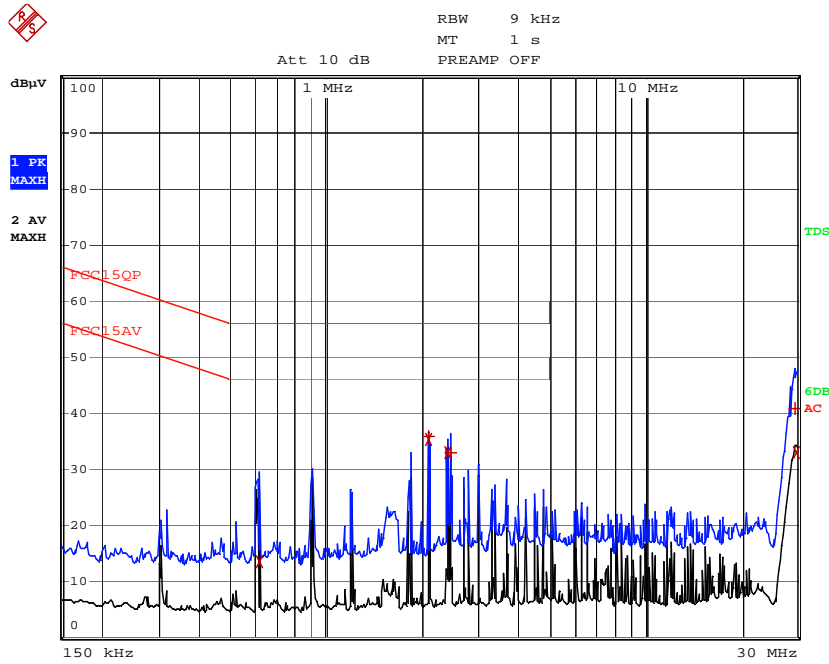

Tested Wire: Neutral

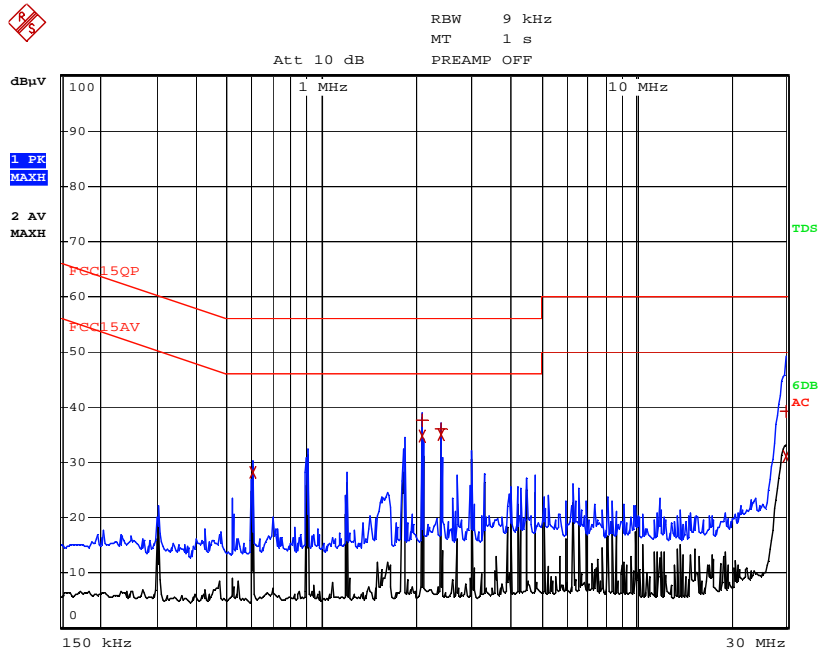





Report No.: 170116067GZU-002  
 Issued: 2017-10-19

## 5.0 Test Equipment List

### Radiated Emission/Radio

Equipment No.	Equipment	Model	Manufacturer	Cal. Due date (MM-DD-YYYY)	Calibration Interval
EM030-04	3m Semi-Anechoic Chamber	9×6×6 m <sup>3</sup>	ETS·LINDGRE N	2018/5/1	1Y
EM031-02	EMI Test Receiver (9 kHz~7 GHz)	R&S ESR7	R&S	2018/3/27	1Y
EM031-03	Signal and Spectrum Analyzer (10 Hz~40 GHz)	R&S FSV40	R&S	2018/5/18	1Y
EM011-04	Loop antenna (9 kHz-30 MHz)	HFH2-Z2	R&S	2018/6/14	1Y
EM061-03	TRILOG Super Broadband test Antenna (30 MHz-1.5 GHz) (TX)	VULB 9161	SCHWARZBECK	2018/6/7	1Y
EM033-01	TRILOG Super Broadband test Antenna(30 MHz-3 GHz) (RX)	VULB 9163	SCHWARZBECK	19/9/2018	1Y
EM033-02	Bouble-Ridged Waveguide Horn Antenna (800 MHz-18 GHz)(RX)	R&S HF907	R&S	2018/6/7	1Y
EM033-03	High Frequency Antenna & preamplifier(18 GHz~26.5 GHz) (RX)	R&S SCU-26	R&S	2018/5/4	1Y
EM033-04	High Frequency Antenna & preamplifier (26 GHz-40 GHz)	R&S SCU-40	R&S	2018/5/4	1Y
EM031-02-01	Coaxial cable(9 kHz-1 GHz)	N/A	R&S	2018/5/18	1Y
EM033-02-02	Coaxial cable(1 GHz-18 GHz)	N/A	R&S	2018/5/18	1Y
EM033-04-02	Coaxial cable(18 GHz~40 GHz)	N/A	R&S	2018/5/25	1Y
EM031-01	Signal Generator (9 kHz~6 GHz)	SMB100A	R&S	2018/8/1	1Y
EM085-02	Signal Generator (10MHz-40GHz)	68369B	Wiltron	2018/5/31	1Y
EM040-01	Band Reject/Notch Filter	WRHFV	Wainwright	N/A	1Y
EM040-02	Band Reject/Notch Filter	WRCGV	Wainwright	N/A	1Y
EM040-03	Band Reject/Notch Filter	WRCGV	Wainwright	N/A	1Y
EM022-03	2.45 GHz Filter	BRM50702	Micro-Tronics	2018/5/9	1Y
SA016-16	Programmable Temperature & Humidity Test Chamber	MHU-800LJ	TERCHY	2017/10/21	1Y
SA016-22	Climatic Test Chamber	C7-1500	Vötsch	2017/10/21	1Y
SA012-74	Digital Multimeter	FLUKE175	FLUKE	2017/10/13	1Y
EM010-01	Regulated DC Power supply	PAB-3003A	GUANHUA	N/A	1Y
SA040-22	Regulated DC Power supply	IT6721	ITECH	2018/9/14	1Y
EM084-06	Audio Analyzer	8903B	HP	2018/4/3	1Y
EM084-07	Modulation Analyzer	8901B	HP	2018/6/15	1Y
EM045-01-01	EMC32 software (RE/RS)	V10.01.00	R&S	N/A	N/A
EM045-01-09	EMC32 software (328/893)	V9.26.01	R&S	N/A	N/A

### Conducted emission at the mains terminals

Equipment No.	Equipment	Model	Manufacturer	Cal. Due date (YYYY-MM-DD)	Calibration Interval
EM080-05	EMI receiver	ESCI	R&S	2018/7/24	1Y
EM006-05	LISN	ENV216	R&S	2018/6/4	1Y
EM006-06	LISN	ENV216	R&S	2018/9/14	1Y
EM006-06-01	Coaxial cable	/	R&S	2018/4/6	1Y
EM004-04	EMC shield Room	8m×3m×3m	Zhongyu	2018/1/23	1Y

\*\*\*\*\*End of the test report\*\*\*\*\*

FCC ID: 2AMPX-40VM900006  
 TRF No.: FCC WIFI-b