

# EMC TEST REPORT



Report No.: 17020787-FCC-E1

Supersede Report No.: N/A

Applicant	RayMeasure Medical Technology Co., Ltd	
Product Name	Femtosecond Clock Distribution System	
Model No.	R1	
Serial No.	N/A	
Test Standard	FCC Part 15 Subpart B Class B:2016, ANSI C63.4: 2014	
Test Date	July 25 to July 26, 2017	
Issue Date	July 28, 2017	
Test Result	<input checked="" type="checkbox"/> Pass <input type="checkbox"/> Fail	
Equipment complied with the specification	<input checked="" type="checkbox"/>	
Equipment did not comply with the specification	<input type="checkbox"/>	
<i>peter wei</i>	<i>Deon Dai</i>	
Peter Wei Test Engineer	Deon Dai Engineer Reviewer	
<p>This test report may be reproduced in full only                  Test result presented in this test report is applicable to the tested sample only</p>		

Issued by:

**SIEMIC (Nanjing-China) Laboratories**

2-1 Longcang Avenue Yuhua Economic and  
Technology Development Park, Nanjing, China

Tel: +86(25)86730128/86730129 Fax: +86(25)86730127 Email: [China@siemic.com.cn](mailto:China@siemic.com.cn)

## Laboratories Introduction

SIEMIC, headquartered in the heart of Silicon Valley, with superior facilities in US and Asia, is one of the leading independent testing and certification facilities providing customers with one-stop shop services for Compliance Testing and Global Certifications.



In addition to testing and certification, SIEMIC provides initial design reviews and compliance management throughout a project. Our extensive experience with China, Asia Pacific, North America, European, and International compliance requirements, assures the fastest, most cost effective way to attain regulatory compliance for the global markets.

### Accreditations for Conformity Assessment

Country/Region	Scope
USA	EMC, RF/Wireless, SAR, Telecom
Canada	EMC, RF/Wireless, SAR, Telecom
Taiwan	EMC, RF, Telecom, SAR, Safety
Hong Kong	RF/Wireless, SAR, Telecom
Australia	EMC, RF, Telecom, SAR, Safety
Korea	EMI, EMS, RF, SAR, Telecom, Safety
Japan	EMI, RF/Wireless, SAR, Telecom
Singapore	EMC, RF, SAR, Telecom
Europe	EMC, RF, SAR, Telecom, Safety

Test Report No.	17020787-FCC-E1
Page	3 of 31

---

This page has been left blank intentionally.

## CONTENTS

<b>1. REPORT REVISION HISTORY.....</b>	<b>5</b>
<b>2. CUSTOMER INFORMATION .....</b>	<b>5</b>
<b>3. TEST SITE INFORMATION.....</b>	<b>5</b>
<b>4. EQUIPMENT UNDER TEST (EUT) INFORMATION .....</b>	<b>6</b>
<b>5. TEST SUMMARY.....</b>	<b>7</b>
<b>6. MEASUREMENTS, EXAMINATION AND DERIVED RESULTS .....</b>	<b>8</b>
6.1 AC POWER LINE CONDUCTED EMISSIONS.....	8
6.2 RADIATED EMISSIONS.....	14
<b>ANNEX A. TEST INSTRUMENT.....</b>	<b>18</b>
<b>ANNEX B. EUT AND TEST SETUP PHOTOGRAPHS .....</b>	<b>19</b>
<b>ANNEX C. TEST SETUP AND SUPPORTING EQUIPMENT.....</b>	<b>27</b>
<b>ANNEX D. USER MANUAL / BLOCK DIAGRAM / SCHEMATICS / PARTLIST.....</b>	<b>30</b>
<b>ANNEX E. DECLARATION OF SIMILARITY .....</b>	<b>31</b>

## 1. Report Revision History

Report No.	Report Version	Description	Issue Date
17020787-FCC-E1	NONE	Original	July 28, 2017

## 2. Customer information

Applicant Name	RayMeasure Medical Technology Co., Ltd
Applicant Add	2F Building 17, 8 Jinfeng Road. Suzhou New District, Suzhou, Jiangsu province, China
Manufacturer	RayMeasure Medical Technology Co., Ltd
Manufacturer Add	2F Building 17, 8 Jinfeng Road. Suzhou New District, Suzhou, Jiangsu province, China

## 3. Test site information

Lab performing tests	SIEMIC (Nanjing-China) Laboratories
Lab Address	2-1 Longcang Avenue Yuhua Economic and Technology Development Park, Nanjing, China
FCC Test Site No.	694825
IC Test Site No.	4842B-1
Test Software	EZ EMC

#### 4. Equipment under Test (EUT) Information

Description of EUT:	Femtosecond Clock Distribution System
Date EUT received:	June 30, 2017
Test Date(s):	July 25 to July 26, 2017
Main Model:	R1
Serial Model:	N/A
Input Power:	XP Power: Model:VEP36US12 Input Power:100-240V~0.9A,50/60Hz Output:12V,3A
Port:	Power Port、 LAN Port、 USB Port
Trade Name :	DexClcok
Test Software Version	1.1.2.0
FCC ID:	2AMPU-010000

## 5. Test Summary

The product was tested in accordance with the following specifications.  
All testing has been performed according to below product classification:

FCC Rules	Description of Test	Result
§15.107; ANSI C63.4: 2014	AC Power Line Conducted Emissions	Compliance
§15.109; ANSI C63.4: 2014	Radiated Emissions	Compliance

### Measurement Uncertainty

Emissions		
Test Item	Description	Uncertainty
Band Edge and Radiated Spurious Emissions	Confidence level of approximately 95% (in the case where distributions are normal), with a coverage factor of 2 (for EUTs < 0.5m X 0.5m X 0.5m)	+5.6dB/-4.5dB

## 6. Measurements, Examination And Derived Results

### 6.1 AC Power Line Conducted Emissions

Temperature	24°C
Relative Humidity	56%
Atmospheric Pressure	1023mbar
Test date :	July 25, 2017
Tested By :	Peter Wei

#### Requirement(s):

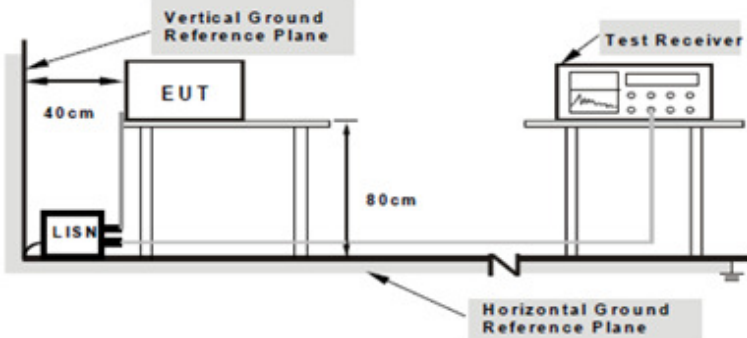
Spec	Item	Requirement	Applicable														
47CFR§15.107	a)	<p>For Low-power radio-frequency devices that is designed to be connected to the public utility (AC) power line, the radio frequency voltage that is conducted back onto the AC power line on any frequency or frequencies, within the band 150 kHz to 30 MHz, shall not exceed the limits in the following table, as measured using a 50 [mu] H/50 ohms line impedance stabilization network (LISN). The lower limit applies at the boundary between the frequencies ranges.</p> <table border="1"> <thead> <tr> <th rowspan="2">Frequency ranges (MHz)</th> <th colspan="2">Limit (dBµV)</th> </tr> <tr> <th>QP</th> <th>Average</th> </tr> </thead> <tbody> <tr> <td>0.15 ~ 0.5</td> <td>66</td> <td>56</td> </tr> <tr> <td>0.5 ~ 5</td> <td>56</td> <td>46</td> </tr> <tr> <td>5 ~ 30</td> <td>60</td> <td>50</td> </tr> </tbody> </table>	Frequency ranges (MHz)	Limit (dBµV)		QP	Average	0.15 ~ 0.5	66	56	0.5 ~ 5	56	46	5 ~ 30	60	50	☒
Frequency ranges (MHz)	Limit (dBµV)																
	QP	Average															
0.15 ~ 0.5	66	56															
0.5 ~ 5	56	46															
5 ~ 30	60	50															
Test Setup		 <p>Note: 1.Support units were connected to second LISN. 2.Both of LISNs (AMN) are 80cm from EUT and at least 80cm from other units and other metal planes support units.</p>															
Procedure		<ol style="list-style-type: none"> <li>The EUT and supporting equipment were set up in accordance with the requirements of the standard on top of a 1.5m x 1m x 0.8m high, non-metallic table.</li> <li>The power supply for the EUT was fed through a 50Ω/50mH EUT LISN, connected to filtered mains.</li> <li>The RF OUT of the EUT LISN was connected to the EMI test receiver via a low-loss coaxial cable.</li> <li>All other supporting equipment were powered separately from another main supply.</li> <li>The EUT was switched on and allowed to warm up to its normal operating condition.</li> <li>A scan was made on the NEUTRAL line (for AC mains) or Earth line (for DC power) over the required frequency range using an EMI test receiver.</li> <li>High peaks, relative to the limit line, The EMI test receiver was then tuned to the selected frequencies and the necessary measurements made with a receiver bandwidth setting of 10 kHz.</li> <li>Step 7 was then repeated for the LIVE line (for AC mains) or DC line (for DC power).</li> </ol>															
Remark																	
Result		☒ Pass      ☐ Fail															

Test Data  Yes  N/A

Test Plot  Yes (See below)  N/A

**Data sample**

No.	Frequency (MHz)	Reading (dBμV)	Detector	Lisn/Isn (dB)	Ps_Lmt (dB)	Cab_L (dB)	Result (dBμV)	Limit (dBμV)	Margin (dB)

Frequency (MHz) = Emission frequency in MHz

Reading (dBμV) = Receiver Reading Value

Detector=Quasi Peak Detector or Average Detector

Lisn/ISN= Insertion loss of LISN

Ps\_Lmt= Insertion loss of transient limiter (The transient limiter included 10dB attenuation)

Cab\_L= cable loss

Result (dBμV) = Reading Value + Corrected Value

Limit (dBμV) = Limit stated in standard

**Calculation Formula:**

Margin (dB) = Result (dBμV) – limit (dBμV)

<b>Test Mode :</b>	<b>Normal Working Mode</b>
--------------------	----------------------------

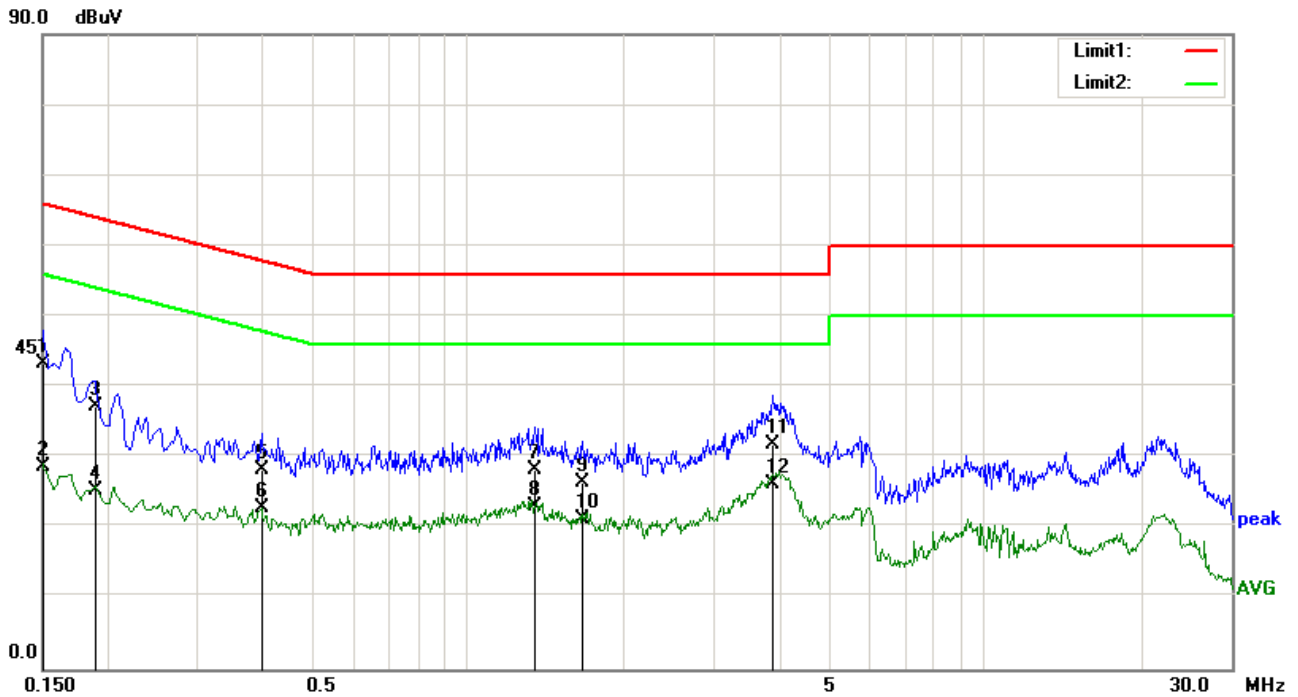

**Test Data**

**Phase Line Plot at 120Vac, 60Hz**

No.	Frequency (MHz)	Reading (dBuV)	Detector	Lisn/Isn (dB)	Ps_Lmt (dB)	Cab_L (dB)	Result (dBuV)	Limit (dBuV)	Margin (dB)
1	0.1500	32.91	QP	0.10	-10.00	0.36	43.37	66.00	-22.63
2	0.1500	18.20	AVG	0.10	-10.00	0.36	28.66	56.00	-27.34
3	0.1900	26.91	QP	0.10	-10.00	0.30	37.31	64.04	-26.73
4	0.1900	15.00	AVG	0.10	-10.00	0.30	25.40	54.04	-28.64
5	0.3980	17.97	QP	0.11	-10.00	0.21	28.29	57.90	-29.61
6	0.3980	12.44	AVG	0.11	-10.00	0.21	22.76	47.90	-25.14
7	1.3460	17.98	QP	0.15	-10.00	0.21	28.34	56.00	-27.66
8	1.3460	12.71	AVG	0.15	-10.00	0.21	23.07	46.00	-22.93
9	1.6660	16.01	QP	0.15	-10.00	0.21	26.37	56.00	-29.63
10	1.6660	10.91	AVG	0.15	-10.00	0.21	21.27	46.00	-24.73
11	3.8980	21.26	QP	0.23	-10.00	0.26	31.75	56.00	-24.25
12	3.8980	15.66	AVG	0.23	-10.00	0.26	26.15	46.00	-19.85

**Test Mode :** Normal Working Mode

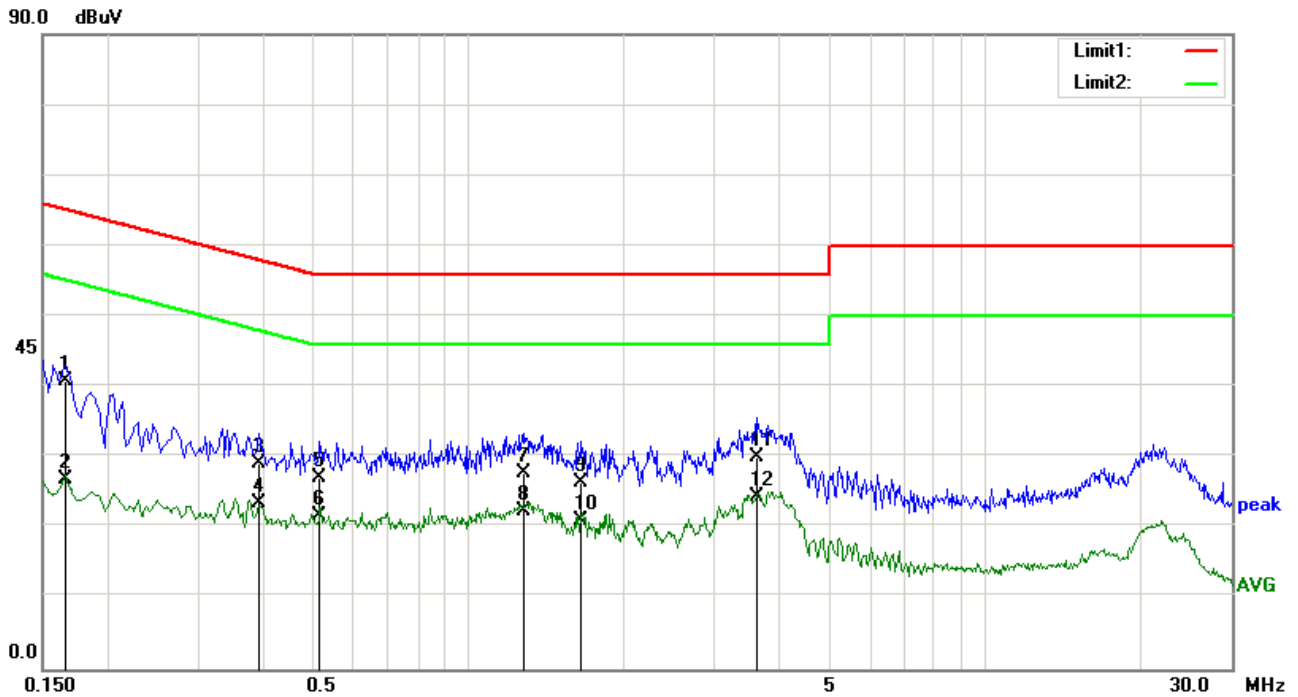

**Test Data**

**Phase Neutral Plot at 120Vac, 60Hz**

No.	Frequency (MHz)	Reading (dBuV)	Detector	Lisn/Isn (dB)	Ps_Lmt (dB)	Cab_L (dB)	Result (dBuV)	Limit (dBuV)	Margin (dB)
1	0.1660	30.37	QP	0.11	-10.00	0.33	40.81	65.16	-24.35
2	0.1660	16.50	AVG	0.11	-10.00	0.33	26.94	55.16	-28.22
3	0.3940	18.86	QP	0.11	-10.00	0.21	29.18	57.98	-28.80
4	0.3940	13.26	AVG	0.11	-10.00	0.21	23.58	47.98	-24.40
5	0.5180	16.70	QP	0.11	-10.00	0.21	27.02	56.00	-28.98
6	0.5180	11.33	AVG	0.11	-10.00	0.21	21.65	46.00	-24.35
7	1.2860	17.34	QP	0.14	-10.00	0.21	27.69	56.00	-28.31
8	1.2860	12.01	AVG	0.14	-10.00	0.21	22.36	46.00	-23.64
9	1.6540	15.98	QP	0.16	-10.00	0.21	26.35	56.00	-29.65
10	1.6540	10.63	AVG	0.16	-10.00	0.21	21.00	46.00	-25.00
11	3.6300	19.62	QP	0.23	-10.00	0.25	30.10	56.00	-25.90
12	3.6300	14.02	AVG	0.23	-10.00	0.25	24.50	46.00	-21.50

**Test Mode :** Normal Working Mode

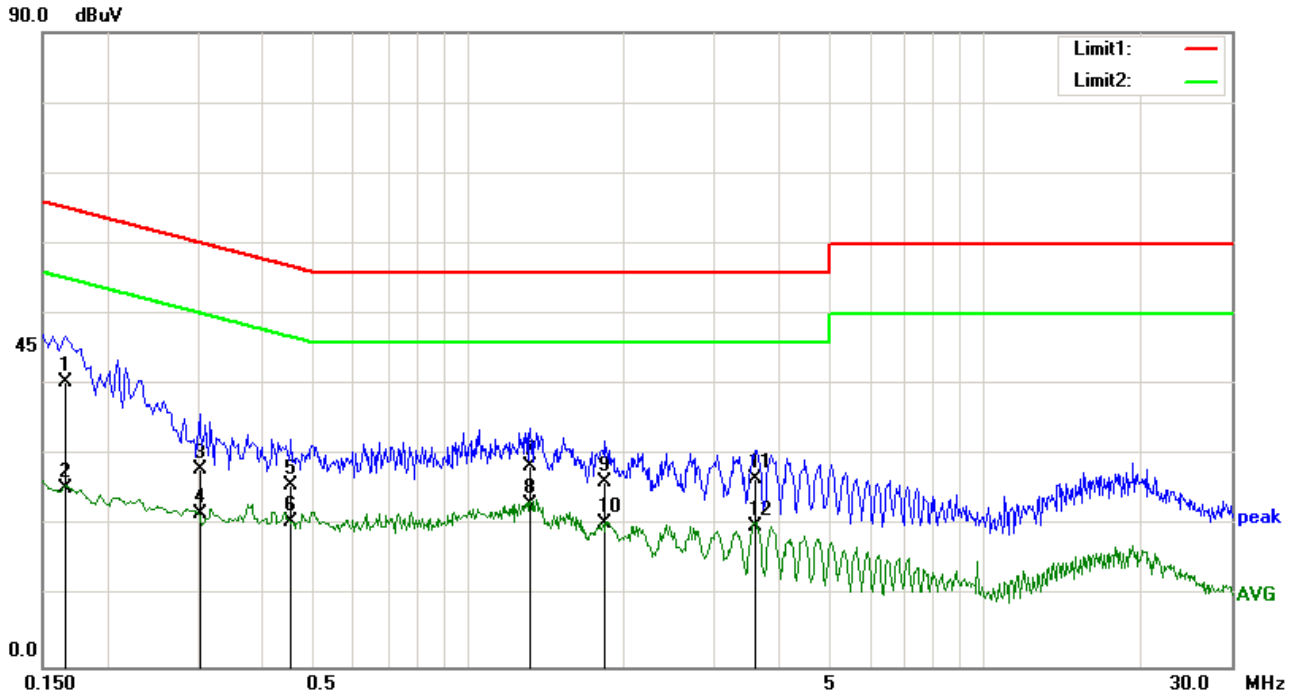

**Test Data**

**Phase Line Plot at 230Vac, 50Hz**

No.	Frequency (MHz)	Reading (dBuV)	Detector	Lisn/Isn (dB)	Ps_Lmt (dB)	Cab_L (dB)	Result (dBuV)	Limit (dBuV)	Margin (dB)
1	0.1660	29.99	QP	0.10	-10.00	0.33	40.42	65.16	-24.74
2	0.1660	14.93	AVG	0.10	-10.00	0.33	25.36	55.16	-29.80
3	0.3020	17.75	QP	0.11	-10.00	0.20	28.06	60.19	-32.13
4	0.3020	11.43	AVG	0.11	-10.00	0.20	21.74	50.19	-28.45
5	0.4540	15.53	QP	0.12	-10.00	0.21	25.86	56.80	-30.94
6	0.4540	10.35	AVG	0.12	-10.00	0.21	20.68	46.80	-26.12
7	1.3220	18.18	QP	0.15	-10.00	0.21	28.54	56.00	-27.46
8	1.3220	12.66	AVG	0.15	-10.00	0.21	23.02	46.00	-22.98
9	1.8460	15.87	QP	0.16	-10.00	0.20	26.23	56.00	-29.77
10	1.8460	9.96	AVG	0.16	-10.00	0.20	20.32	46.00	-25.68
11	3.6020	16.24	QP	0.22	-10.00	0.25	26.71	56.00	-29.29
12	3.6020	9.50	AVG	0.22	-10.00	0.25	19.97	46.00	-26.03

**Test Mode :** Normal Working Mode

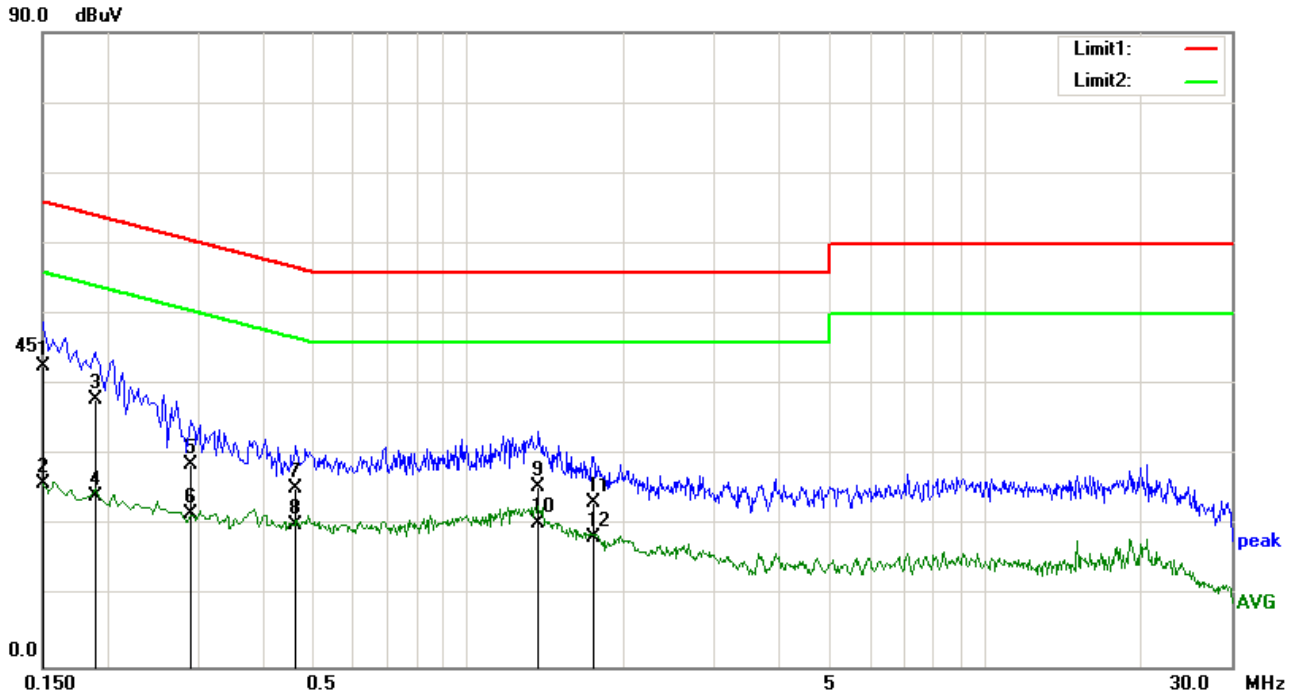

**Test Data**

**Phase Neutral Plot at 230Vac, 50Hz**

No.	Frequency (MHz)	Reading (dBuV)	Detector	Lisn/Isn (dB)	Ps_Lmt (dB)	Cab_L (dB)	Result (dBuV)	Limit (dBuV)	Margin (dB)
1	0.1500	32.23	QP	0.11	-10.00	0.36	42.70	66.00	-23.30
2	0.1500	15.49	AVG	0.11	-10.00	0.36	25.96	56.00	-30.04
3	0.1900	27.55	QP	0.10	-10.00	0.30	37.95	64.04	-26.09
4	0.1900	13.85	AVG	0.10	-10.00	0.30	24.25	54.04	-29.79
5	0.2900	18.33	QP	0.10	-10.00	0.20	28.63	60.52	-31.89
6	0.2900	11.41	AVG	0.10	-10.00	0.20	21.71	50.52	-28.81
7	0.4660	15.02	QP	0.11	-10.00	0.21	25.34	56.58	-31.24
8	0.4660	9.92	AVG	0.11	-10.00	0.21	20.24	46.58	-26.34
9	1.3700	15.20	QP	0.14	-10.00	0.21	25.55	56.00	-30.45
10	1.3700	10.04	AVG	0.14	-10.00	0.21	20.39	46.00	-25.61
11	1.7500	12.98	QP	0.16	-10.00	0.21	23.35	56.00	-32.65
12	1.7500	7.91	AVG	0.16	-10.00	0.21	18.28	46.00	-27.72

## 6.2 Radiated Emissions

Temperature	24°C
Relative Humidity	56%
Atmospheric Pressure	1023mbar
Test date :	July 26, 2017
Tested By :	Peter Wei

### Requirement(s):

Spec	Item	Requirement	Applicable										
47CFR§15.109(d)	a)	Except higher limit as specified elsewhere in other section, the emissions from the low-power radio-frequency devices shall not exceed the field strength levels specified in the following table and the level of any unwanted emissions shall not exceed the level of the fundamental emission. The tighter limit applies at the band edges	☒										
		<table border="1"> <thead> <tr> <th>Frequency range (MHz)</th> <th>Field Strength (µV/m)</th> </tr> </thead> <tbody> <tr> <td>30 – 88</td> <td>100</td> </tr> <tr> <td>88 – 216</td> <td>150</td> </tr> <tr> <td>216 960</td> <td>200</td> </tr> <tr> <td>Above 960</td> <td>500</td> </tr> </tbody> </table>		Frequency range (MHz)	Field Strength (µV/m)	30 – 88	100	88 – 216	150	216 960	200	Above 960	500
		Frequency range (MHz)		Field Strength (µV/m)									
		30 – 88		100									
		88 – 216		150									
216 960	200												
Above 960	500												

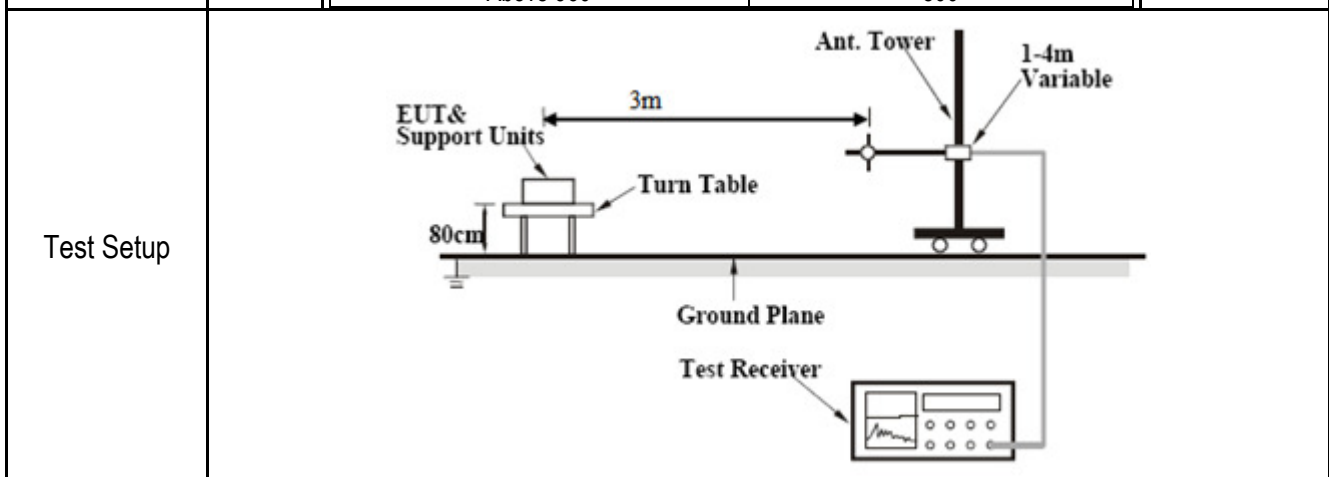

Procedure	<ol style="list-style-type: none"> <li>1. The EUT was switched on and allowed to warm up to its normal operating condition.</li> <li>2. The test was carried out at the selected frequency points obtained from the EUT characterization. Maximization of the emissions, was carried out by rotating the EUT, changing the antenna polarization, and adjusting the antenna height in the following manner:             <ol style="list-style-type: none"> <li>a. Vertical or horizontal polarization (whichever gave the higher emission level over a full rotation of the EUT) was chosen.</li> <li>b. The EUT was then rotated to the direction that gave the maximum emission.</li> <li>c. Finally, the antenna height was adjusted to the height that gave the maximum emission.</li> </ol> </li> <li>3. The resolution bandwidth and video bandwidth of test receiver/spectrum analyzer is 120 kHz for Quasi Peak detection at frequency below 1GHz.</li> <li>4. The resolution bandwidth of test receiver/spectrum analyzer is 1MHz and video bandwidth is 3MHz with Peak detection for Peak measurement at frequency above 1GHz. The resolution bandwidth of test receiver/spectrum analyzer is 1MHz and the video bandwidth with Peak detection for Average Measurement as below at frequency above 1GHz. ■ 1 kHz (Duty cycle &lt; 98%) □ 10 Hz (Duty cycle &gt; 98%)</li> <li>5. Steps 2 and 3 were repeated for the next frequency point, until all selected frequency points were measured.</li> </ol>
-----------	---

Remark	
--------	--

Result	<input checked="" type="checkbox"/> Pass	<input type="checkbox"/> Fail
--------	--	-------------------------------

Test Data  Yes  N/A

Test Plot  Yes (See below)  N/A

**Data sample**

No.	Frequency (MHz)	Reading (dBμV/m)	Detector	Ant_F (dB/m)	PA_G (dB)	Cab_L (dB)	Result (dBμV/m)	Limit (dBμV/m)	Margin (dB)	Height (cm)	Degree (°)

Frequency (MHz) = Emission frequency in MHz

Reading (dBμV/m) = Receiver Reading Value

Detector= Peak Detector or Quasi Peak Detector

Ant\_F=Antenna Factor

PA\_G=Pre-Amplifier Gain

Cab\_L=Cable Loss

Result (dBμV/m) = Reading Value + Corrected Value

Limit (dBμV/m) = Limit stated in standard

Height (cm) = Height of Receiver antenna

Degree = Turn table degree

**Calculation Formula:**

Margin (dB) = Result (dBμV/m) – limit (dBμV/m)

**Test Mode :** Normal Working Mode

**Below 1GHz**

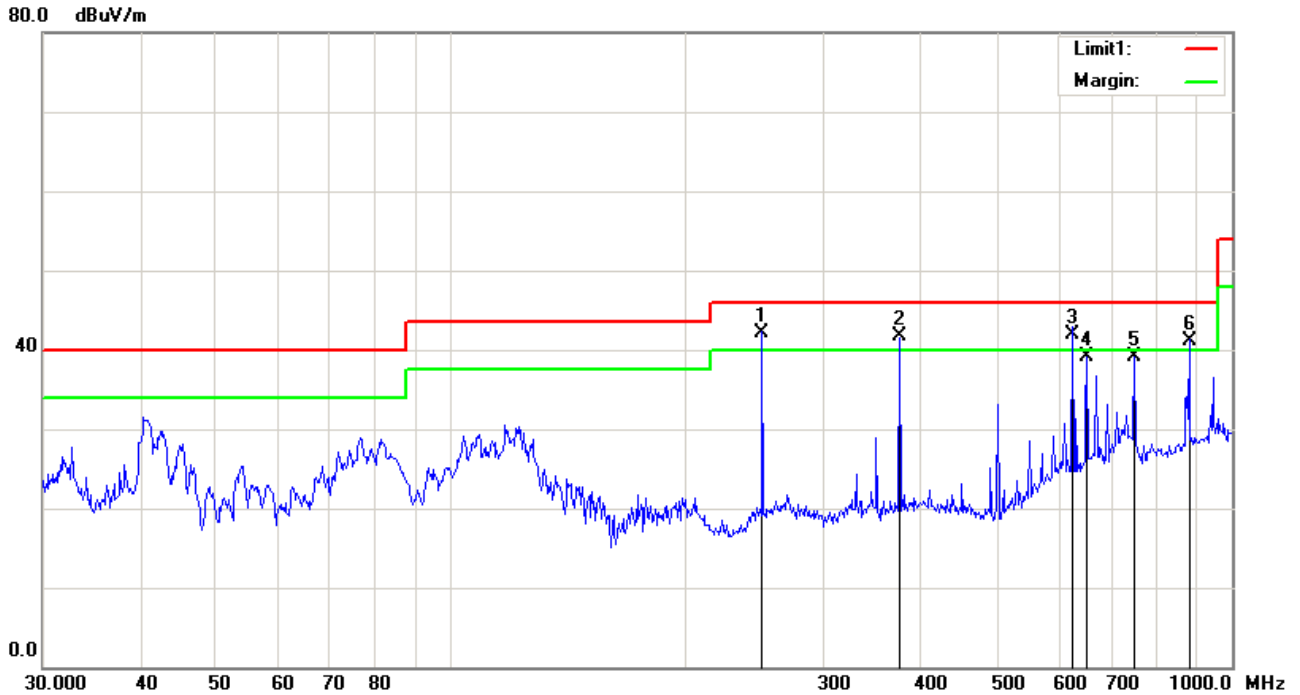

**Test Data**

**Vertical Polarity Plot @3m**

No.	Frequency (MHz)	Reading (dBuV/m)	Detector	Ant F (dB/m)	PA G (dB)	Cab L (dB)	Result (dBuV/m)	Limit (dBuV/m)	Margin (dB)	Height (cm)	Degree (°)
1	250.3012	72.43	QP	14.90	47.74	2.51	42.10	46.00	-3.90	100	326
2	375.9385	70.94	QP	16.51	48.77	3.12	41.80	46.00	-4.20	200	143
3	625.0780	64.12	QP	20.84	46.97	4.01	42.00	46.00	-4.00	100	214
4	651.9417	61.61	peak	21.47	48.15	4.10	39.03	46.00	-6.97	100	165
5	750.1083	57.71	peak	22.07	45.02	4.40	39.16	46.00	-6.84	100	280
6	881.4067	58.97	QP	23.28	45.95	4.80	41.10	46.00	-4.90	200	289

<b>Test Mode :</b>	<b>Normal Working Mode</b>
--------------------	----------------------------

**Below 1GHz**

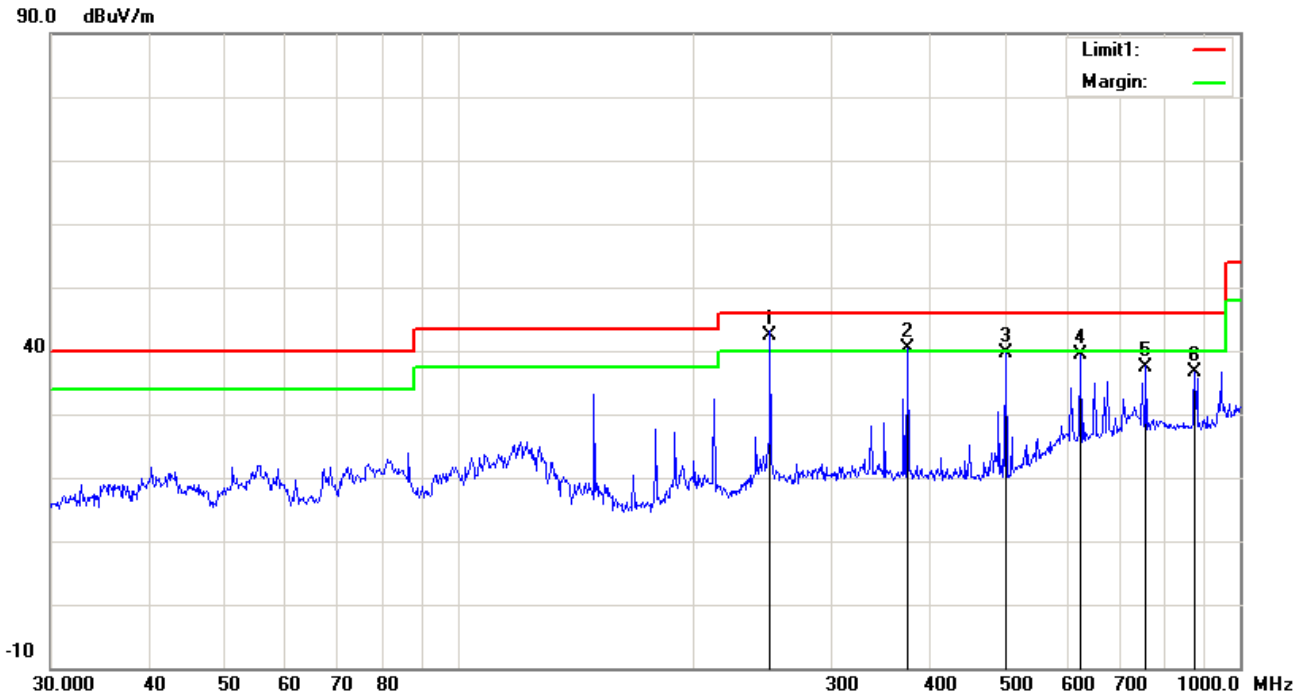

**Test Data**

**Horizontal Polarity Plot @3m**

No.	Frequency (MHz)	Reading (dBuV/m)	Detector	Ant F (dB/m)	PA G (dB)	Cab L (dB)	Result (dBuV/m)	Limit (dBuV/m)	Margin (dB)	Height (cm)	Degree (°)
1	250.3012	72.57	QP	15.16	47.74	2.51	42.50	46.00	-3.50	200	120
2	375.9385	69.86	QP	16.22	48.77	3.12	40.43	46.00	-5.57	300	185
3	501.1790	69.33	peak	16.06	49.27	3.56	39.68	46.00	-6.32	200	219
4	625.0780	60.70	peak	21.55	46.97	4.01	39.29	46.00	-6.71	200	46
5	758.0408	55.29	peak	22.75	44.96	4.42	37.50	46.00	-8.50	300	82
6	875.2470	55.07	peak	22.77	46.00	4.78	36.62	46.00	-9.38	300	286

Note: The highest frequency of the internal sources of the EUT is less than 108MHz, so the measurement shall only be made up to 1GHz.

## Annex A. TEST INSTRUMENT

Instrument	Model	Serial #	Cal Date	Cal Due	In use
<b>AC Line Conducted Emissions</b>					
R&S EMI Test Receiver	ESPI3	101216	05/03/2017	05/02/2018	<input checked="" type="checkbox"/>
V-LISN	ESH3-Z5	838979/005	05/15/2017	05/14/2018	<input checked="" type="checkbox"/>
SIEMIC EZ_EMCConducted Emissions	Ver.ICP-03A1	N/A	N/A	N/A	<input checked="" type="checkbox"/>
<b>Radiated Emissions</b>					
Spectrum Analyzer	N9010A	MY47191130	05/03/2017	05/02/2018	<input type="checkbox"/>
R&S EMI Receiver	ESPI3	101216	05/03/2017	05/02/2018	<input checked="" type="checkbox"/>
Antenna (30MHz~6GHz)	JB6	A121411	10/31/2016	10/31/2017	<input checked="" type="checkbox"/>
EMCO Horn Antenna (1 ~18GHz)	3115	N/A	11/15/2016	11/14/2017	<input type="checkbox"/>
Hp Pre-Amplifier	8447F	1937A01160	10/31/2016	10/30/2017	<input checked="" type="checkbox"/>
Agilent Pre-Amplifier	8449B	N/A	10/31/2016	10/30/2017	<input type="checkbox"/>
SIEMIC EZ_EMCCRadiated Emissions software	Ver.ICP-03A1	N/A	N/A	N/A	<input checked="" type="checkbox"/>

**Annex B. EUT And Test Setup Photographs**

**Annex B.i. Photograph: EUT External Photo**



**The Whole of EUT - Front View**

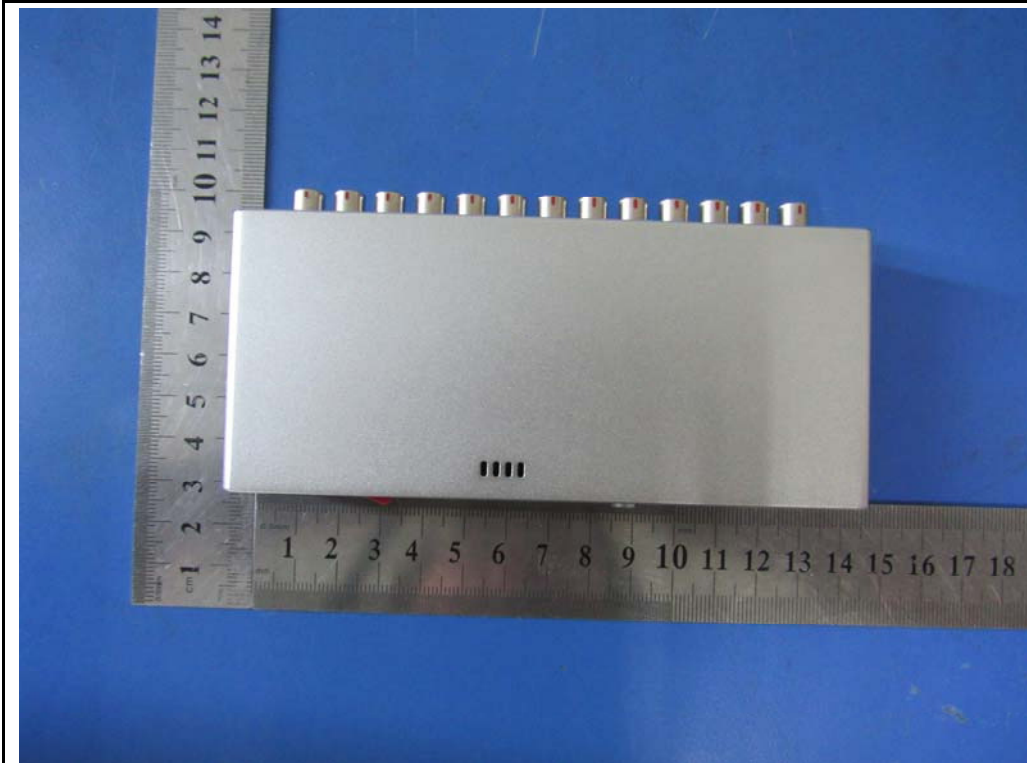

**EUT - Top View**

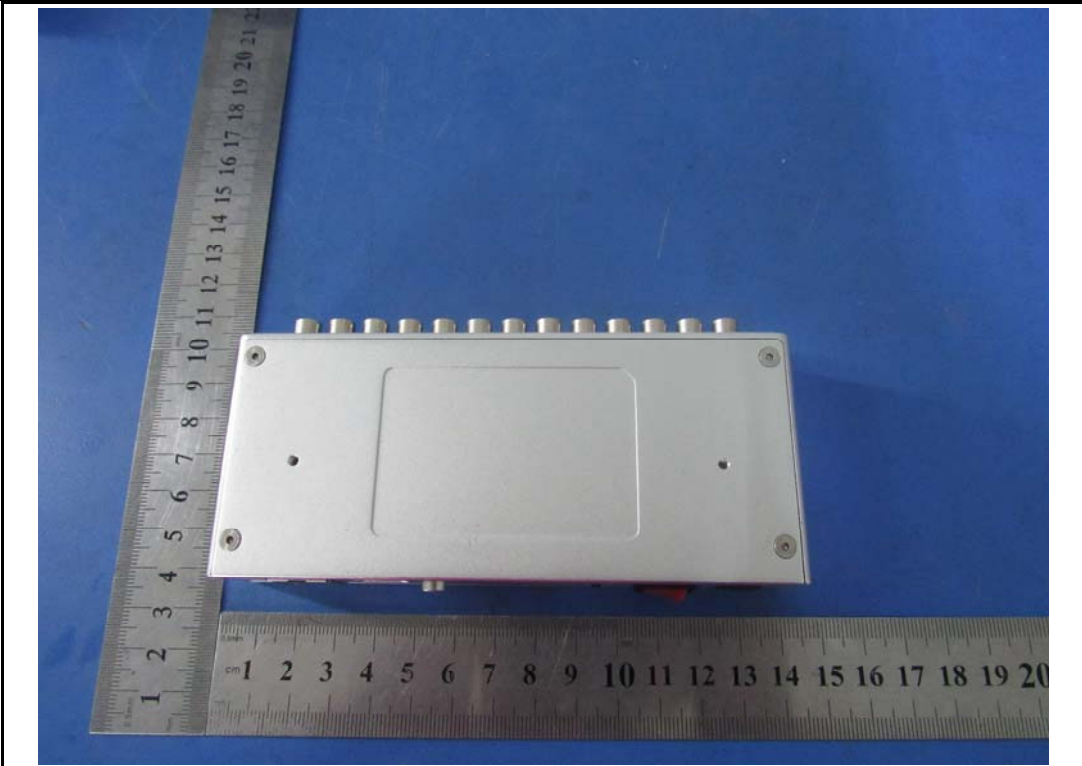

**EUT - Bottom View**



**EUT - Front View**



**EUT - Rear View**

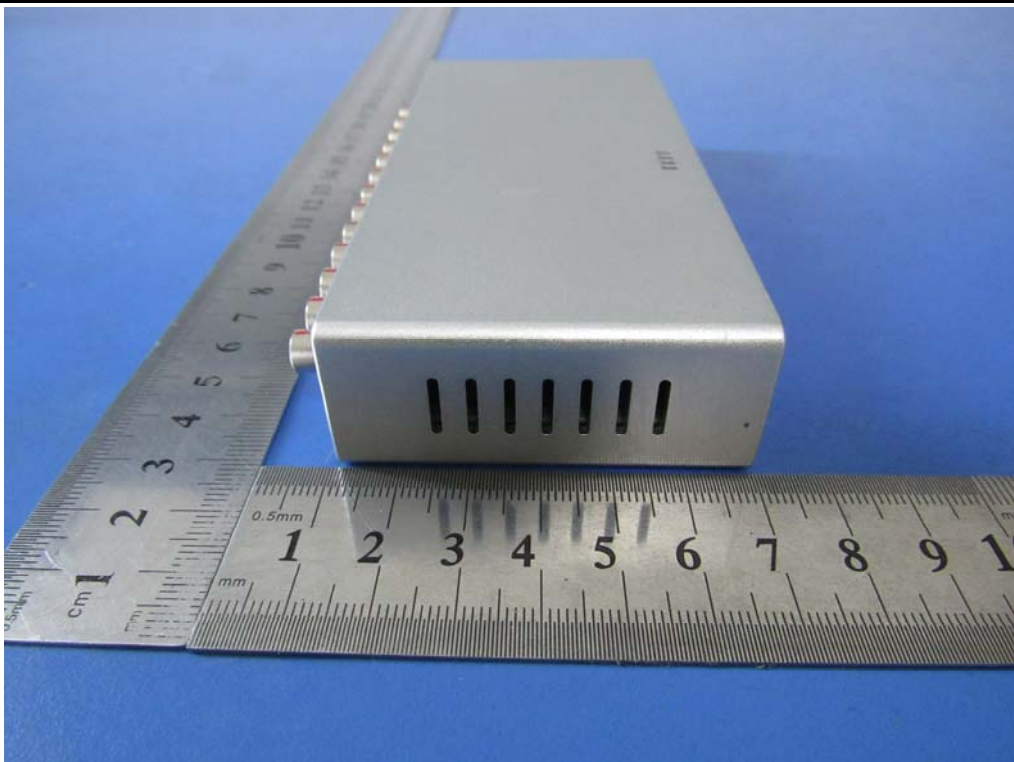

**EUT - Left View**

Test Report No.	17020787-FCC-E1
Page	22 of 31

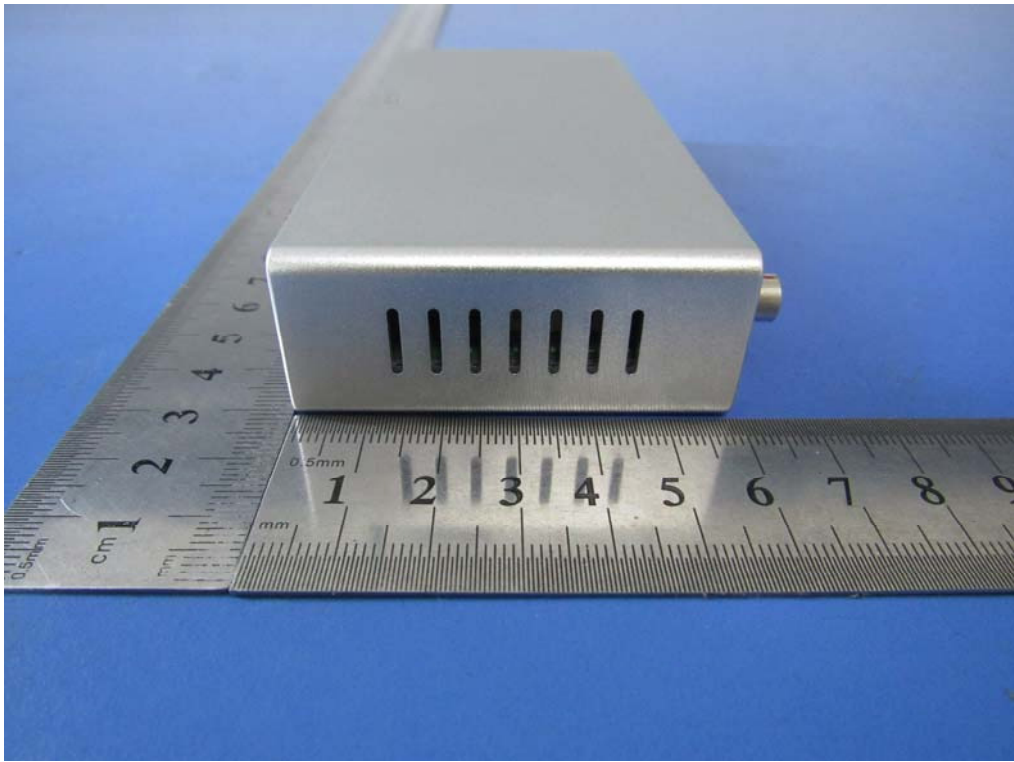

**EUT - Right View**

**Annex B.ii. Photograph: EUT Internal Photo**

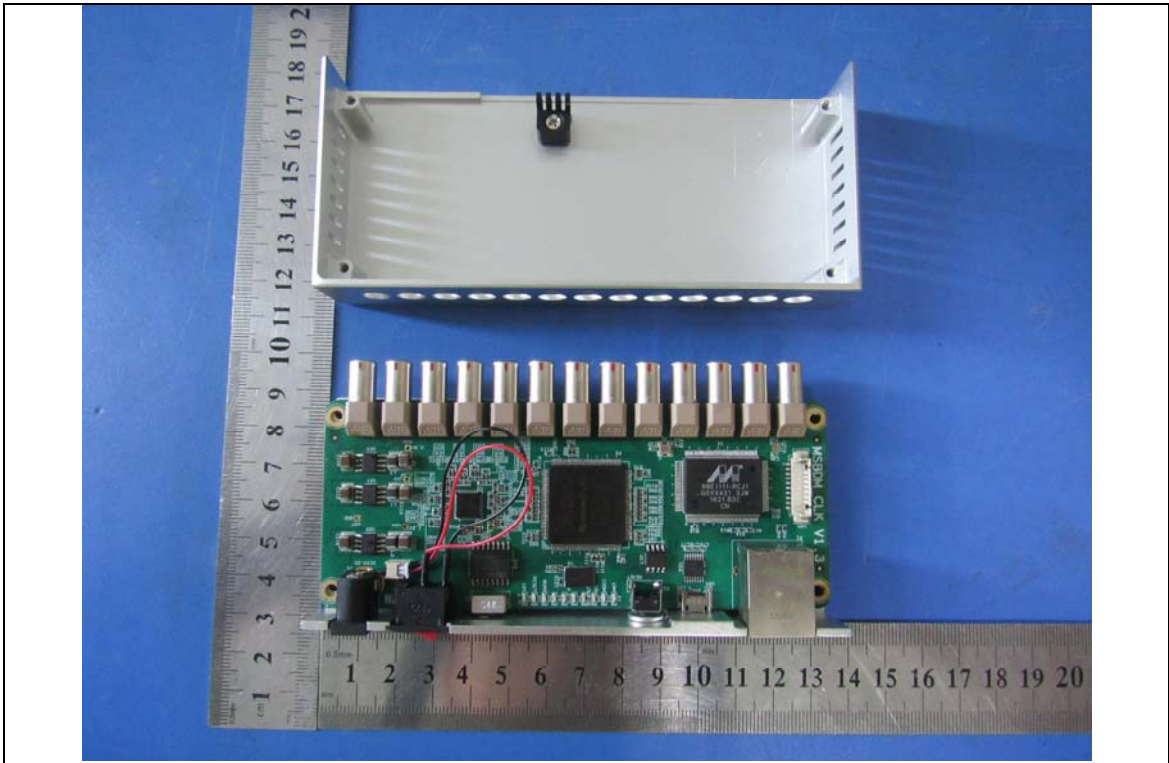

**EUT Uncover – Front View**

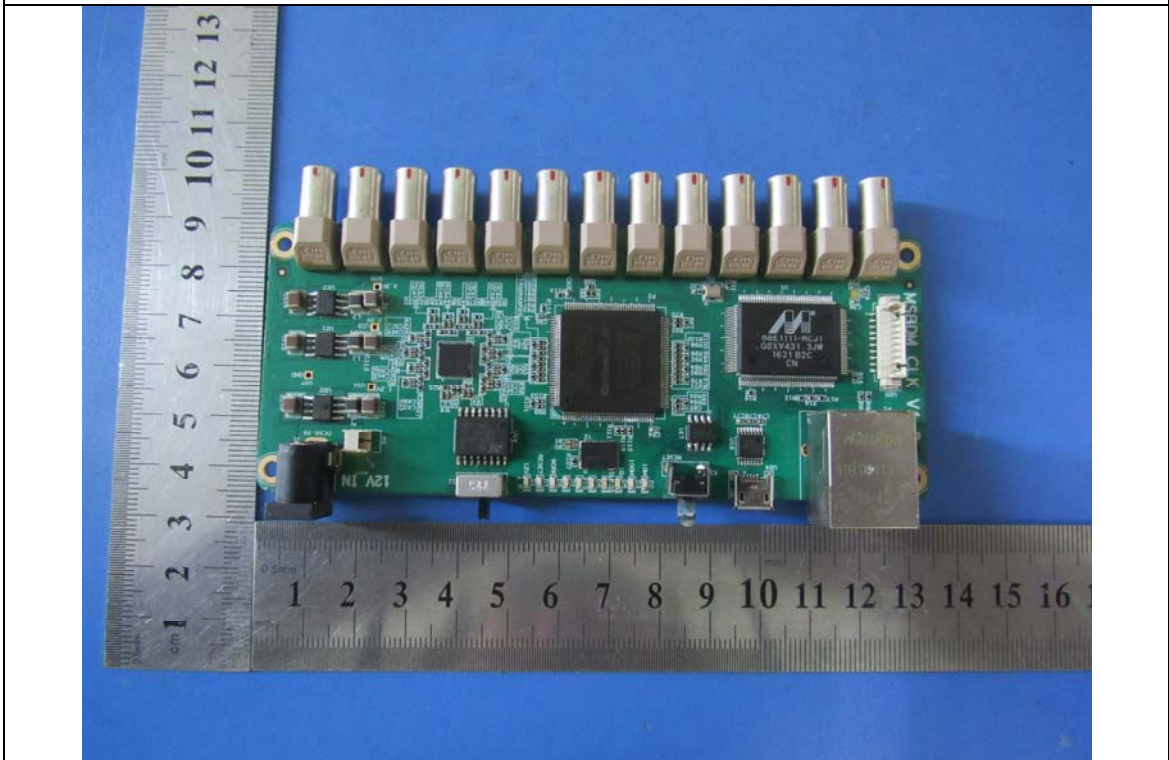

**EUT PCBA – Front View**

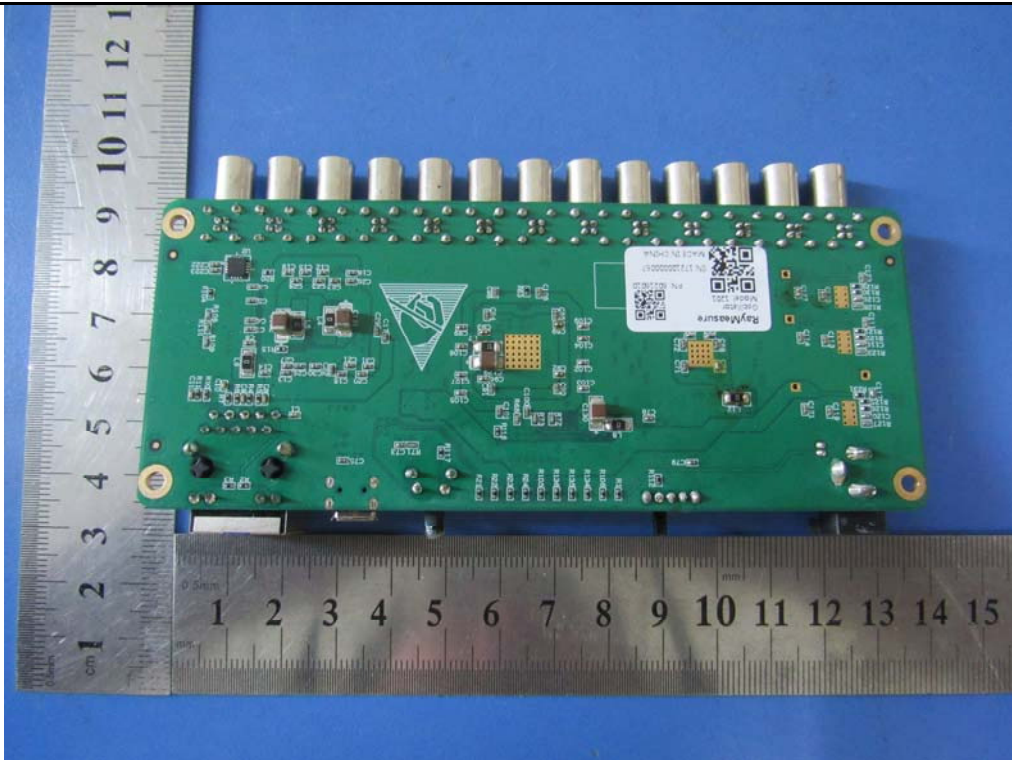

**EUT PCBA – Rear View**

**Annex B.iii. Photograph: Test Setup Photo**



Conducted Emissions Test Setup Front View



Conducted Emissions Test Setup Side View

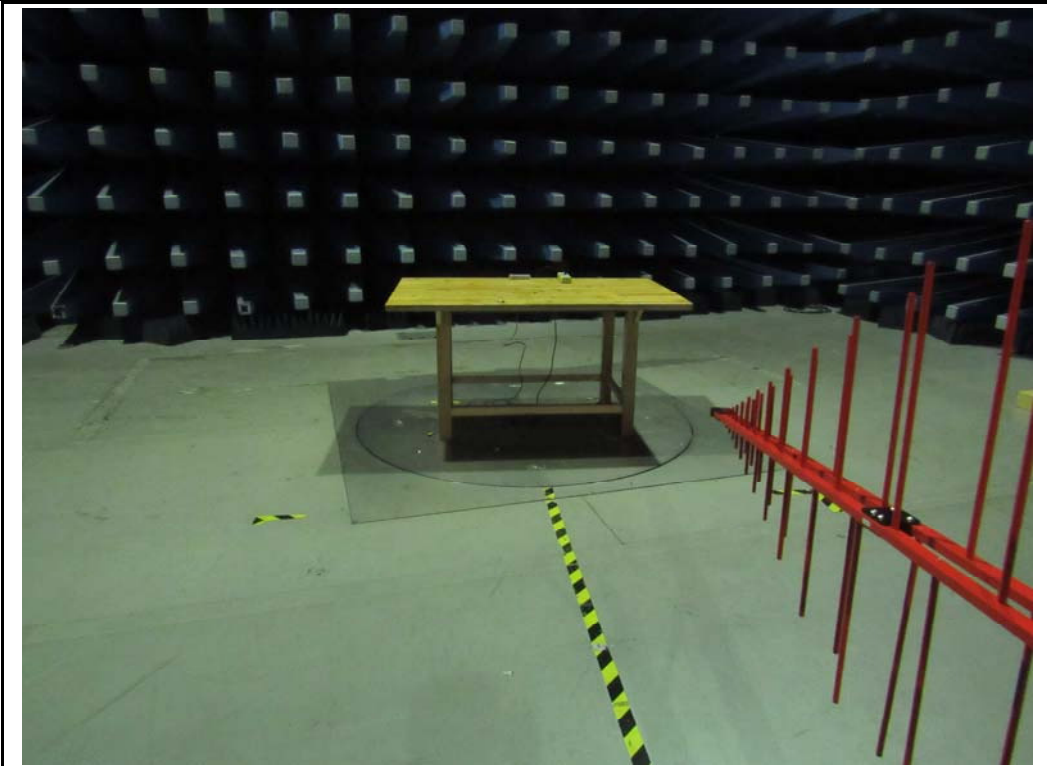

Radiated Spurious Emissions Test Setup Below 1GHz

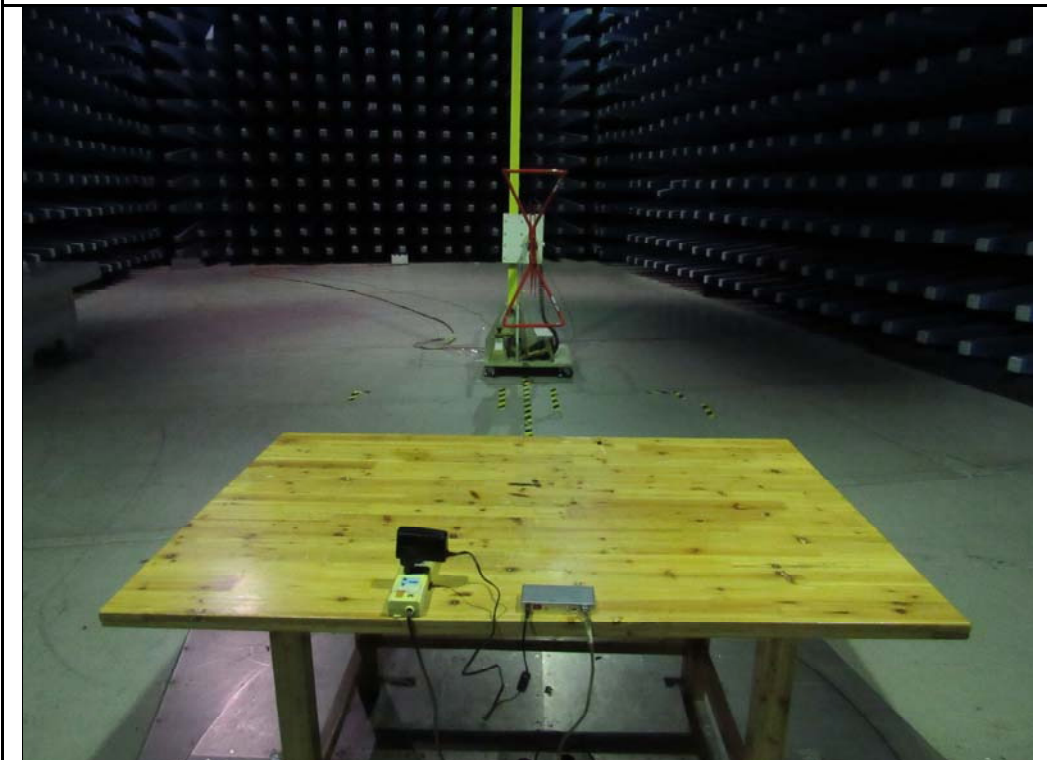

Radiated Spurious Emissions Test Setup Below 1GHz

**Annex C. TEST SETUP AND SUPPORTING EQUIPMENT**

**Annex C.ii. TEST SET UP BLOCK**

**Block Configuration Diagram for Conducted Emissions**

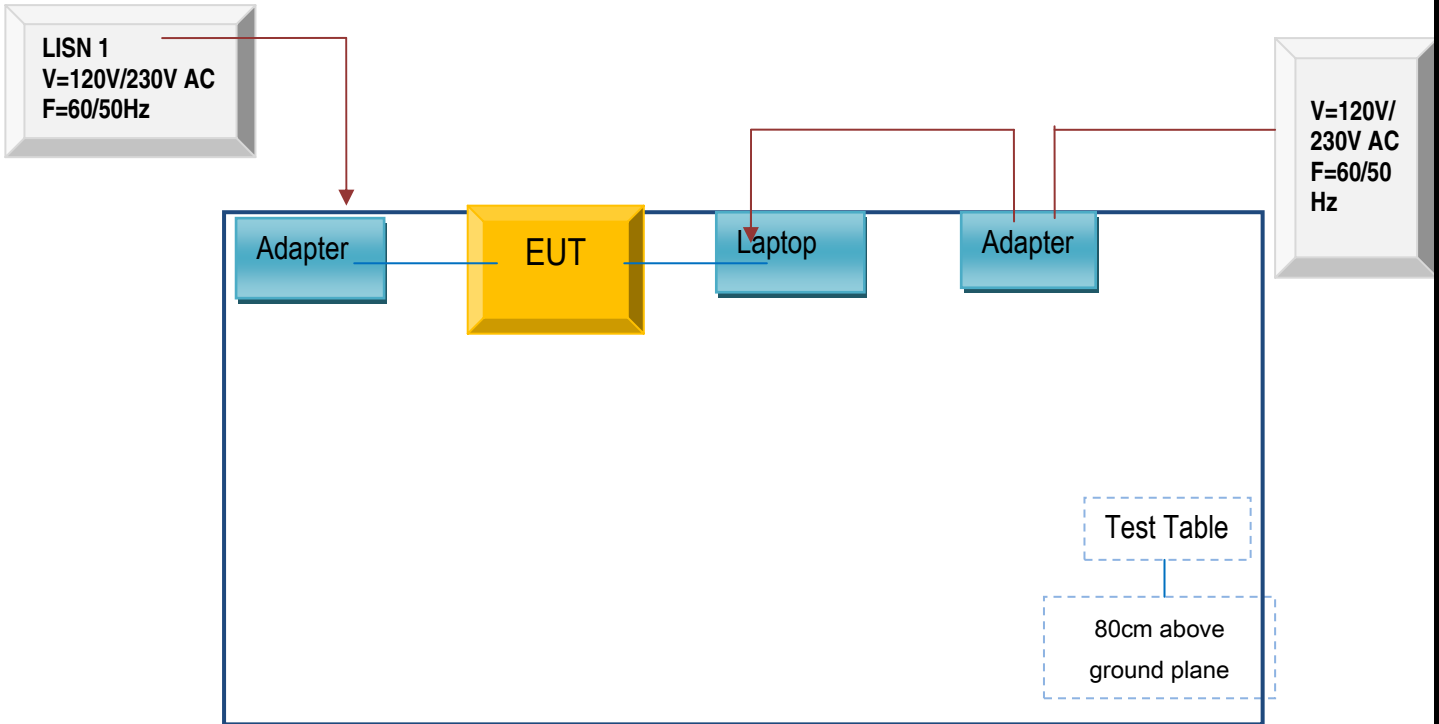

### Block Configuration Diagram for Radiated Emissions

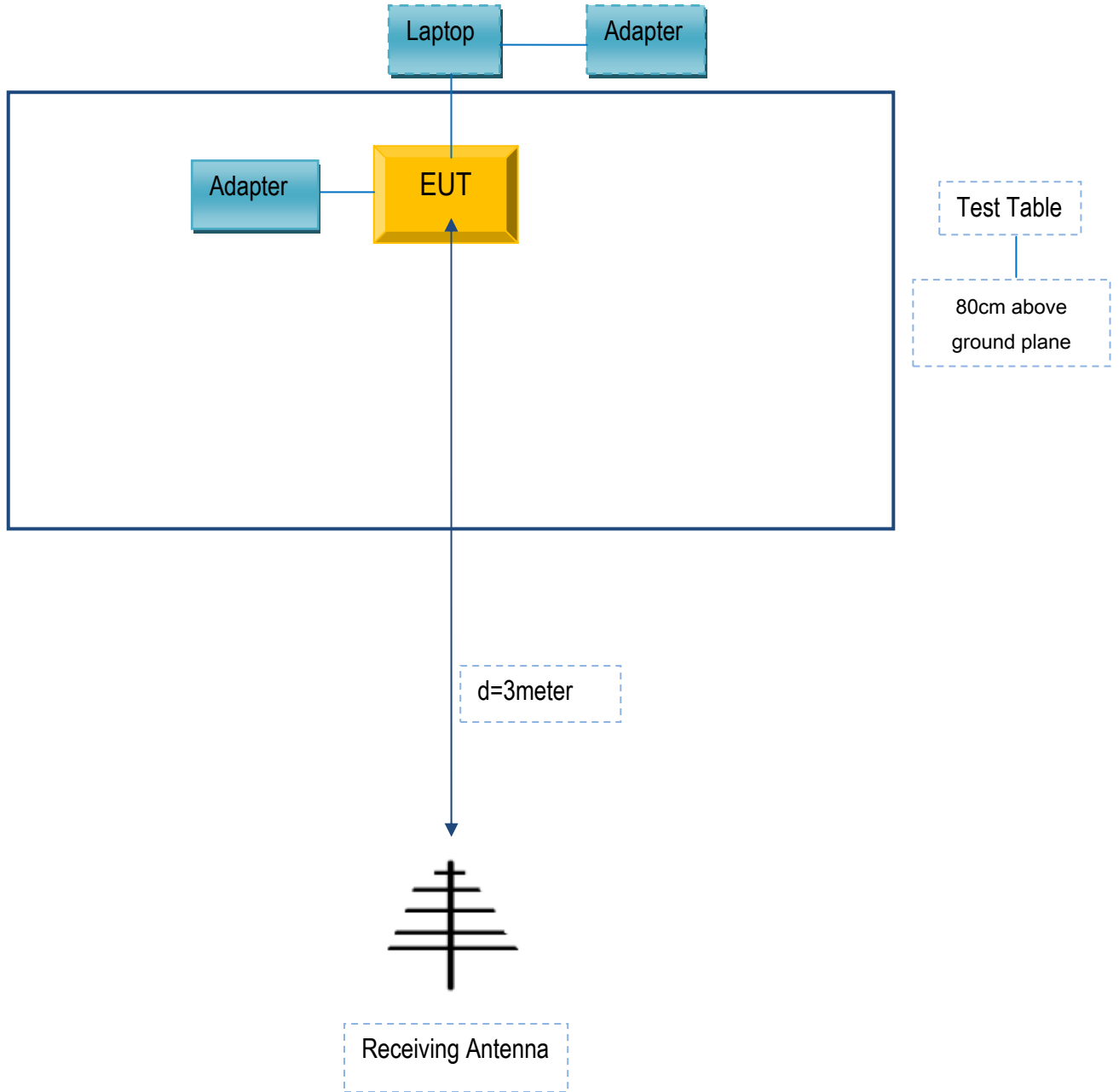

**Annex C. ii. SUPPORTING EQUIPMENT DESCRIPTION**

The following is a description of supporting equipment and details of cables used with the EUT.

**Supporting Equipment:**

Manufacturer	Equipment Description	Model	Serial No
DELL	Laptop	4321S	N/A

**Supporting Cable:**

Cable type	Shield Type	Ferrite Core	Length	Serial No
Power Cable	Un-shielding	No	0.8m	N/A

Test Report No.	17020787-FCC-E1
Page	30 of 31

## **Annex D. User Manual / Block Diagram / Schematics / Partlist**

**See attachment**

Test Report No.	17020787-FCC-E1
Page	31 of 31

## Annex E. DECLARATION OF SIMILARITY

N/A