



Shenzhen Huaxia Testing Technology Co., Ltd.

1F., Block A of Tongsheng Technology Building, Huahui Road, Dalang Street, Longhua District, Shenzhen, China

Telephone: +86-755-26648640

Fax: +86-755-26648637

Website: www.cqa-cert.com

Report Template Version: V05

Report Template Revision Date: 2021-11-03

TEST REPORT

Report No.: CQASZ20220801410E-02
Applicant: ShenZhen Porcsi Technology Co., Ltd.
Address of Applicant: 10/F, Jia Yi Da Industrial Park, Liao Keng, ShiYan, BaoAn, ShenZhen, China.
Equipment Under Test (EUT):
Product: Tire Pressure Sensor Programming Tool MateTPMS, TPMS Android Programmer
Model No.: A8, A9, A10, T8, T9, T10, A8 lite, A8 Pro, A8 Plus, A801, A802, A803, 04.01.123
Test Model No.: A8
Brand Name: N/A
FCC ID: 2AMNXA8
Standards: 47 CFR Part 15, Subpart C
Date of Receipt: 2022-08-15
Date of Test: 2022-08-15 to 2022-11-30
Date of Issue: 2023-02-07
Test Result : **PASS***

*In the configuration tested, the EUT complied with the standards specified above

Tested By: _____

Lewis Zhou

(Lewis Zhou)

Reviewed By: _____

Timo Lei

(Timo Lei)

Approved By: _____

Jack Ai

(Jack Ai)



1 Version

Revision History Of Report

Report No.	Version	Description	Issue Date
CQASZ20220801410E-02	Rev.01	Initial report	2023-02-07

2 Test Summary

Test Item	Test Requirement	Test method	Result
Antenna Requirement	47 CFR Part 15, Subpart C Section 15.203/15.247 (c)	ANSI C63.10 2013	PASS
AC Power Line Conducted Emission	47 CFR Part 15, Subpart C Section 15.207	ANSI C63.10 2013	PASS
Conducted Peak & Average Output Power	47 CFR Part 15, Subpart C Section 15.247 (b)(3)	ANSI C63.10 2013	PASS
6dB Occupied Bandwidth	47 CFR Part 15, Subpart C Section 15.247 (a)(2)	ANSI C63.10 2013	PASS
Power Spectral Density	47 CFR Part 15, Subpart C Section 15.247 (e)	ANSI C63.10 2013	PASS
Band-edge for RF Conducted Emissions	47 CFR Part 15, Subpart C Section 15.247(d)	ANSI C63.10 2013	PASS
RF Conducted Spurious Emissions	47 CFR Part 15, Subpart C Section 15.247(d)	ANSI C63.10 2013	PASS
Radiated Spurious Emissions	47 CFR Part 15, Subpart C Section 15.205/15.209	ANSI C63.10 2013	PASS
Restricted bands around fundamental frequency (Radiated Emission)	47 CFR Part 15, Subpart C Section 15.205/15.209	ANSI C63.10 2013	PASS

3 Contents

	Page
1 VERSION	2
2 TEST SUMMARY	3
3 CONTENTS	4
4 GENERAL INFORMATION	5
4.1 CLIENT INFORMATION	5
4.2 GENERAL DESCRIPTION OF EUT	5
4.3 PRODUCT SPECIFICATION SUBJECTIVE TO THIS STANDARD	5
4.4 TEST ENVIRONMENT AND MODE	7
4.5 DESCRIPTION OF SUPPORT UNITS	8
4.6 TEST LOCATION	8
4.7 TEST FACILITY	8
4.8 STATEMENT OF THE MEASUREMENT UNCERTAINTY	9
4.9 DEVIATION FROM STANDARDS	9
4.10 ABNORMALITIES FROM STANDARD CONDITIONS	9
4.11 OTHER INFORMATION REQUESTED BY THE CUSTOMER	9
4.12 EQUIPMENT LIST	10
5 TEST RESULTS AND MEASUREMENT DATA	11
5.1 ANTENNA REQUIREMENT	11
5.2 CONDUCTED EMISSIONS	12
5.3 CONDUCTED PEAK & AVERAGE OUTPUT POWER	16
<i>Test Result</i>	17
<i>Test Graphs</i>	18
5.4 6DB OCCUPY BANDWIDTH	24
<i>Test Result</i>	25
<i>Test Graphs</i>	26
5.5 POWER SPECTRAL DENSITY	32
<i>Test Result</i>	33
<i>Test Graphs</i>	34
5.6 BAND-EDGE FOR RF CONDUCTED EMISSIONS	40
<i>Test Result</i>	41
5.6.1 <i>Test Graphs</i>	42
5.7 RF CONDUCTED SPURIOUS EMISSIONS	47
<i>Test Result</i>	48
<i>Test Graphs</i>	50
5.8 RADIATED SPURIOUS EMISSIONS	68
5.8.1 <i>Radiated emission below 1GHz</i>	71
5.8.2 <i>Transmitter emission above 1GHz</i>	73
5.9 RESTRICTED BANDS AROUND FUNDAMENTAL FREQUENCY	75
6 PHOTOGRAPHS - EUT TEST SETUP	81
6.1 RADIATED SPURIOUS EMISSION	81
6.2 CONDUCTED EMISSION	82
7 PHOTOGRAPHS - EUT CONSTRUCTIONAL DETAILS	83

4 General Information

4.1 Client Information

Applicant:	ShenZhen Porcsi Technology Co., Ltd.
Address of Applicant:	10/F, Jia Yi Da Industrial Park, Liao Keng, ShiYan, BaoAn, ShenZhen, China.
Manufacturer:	ShenZhen Porcsi Technology Co., Ltd.
Address of Manufacturer:	10/F, Jia Yi Da Industrial Park, Liao Keng, ShiYan, BaoAn, ShenZhen, China.
Factory:	ShenZhen Porcsi Technology Co., Ltd.
Address of Factory:	10/F, Jia Yi Da Industrial Park, Liao Keng, ShiYan, BaoAn, ShenZhen, China.

4.2 General Description of EUT

Product Name:	Tire Pressure Sensor Programming Tool MateTPMS, TPMS Android Programmer
Model No.:	A8, A9, A10, T8, T9, T10, A8 lite, A8 Pro, A8 Plus, A801, A802, A803, 04.01.123
Test Model No.:	A8
Trade Mark:	N/A
Software Version:	Andriod 8.0.1
Hardware Version:	V1.0
Power Supply:	Li-ion battery: DC 3.7V 5000mAh, Charge by DC 5V for adapter
EUT Supports Radios application:	2.4GHz: Wi-Fi: 802.11b/g/n(HT20): 2412MHz~2462MHz

4.3 Product Specification subjective to this standard

Operation Frequency:	IEEE 802.11b/g/n(HT20): 2412MHz to 2462MHz IEEE 802.11n(HT40): 2422MHz to 2452MHz
Channel Numbers:	IEEE 802.11b/g, IEEE 802.11n HT20: 11 Channels IEEE 802.11n HT40: 7 Channels
Channel Separation:	5MHz
Type of Modulation:	IEEE for 802.11b: DSSS(CCK,DQPSK,DBPSK) IEEE for 802.11g : OFDM(64QAM, 16QAM, QPSK, BPSK) IEEE for 802.11n(HT20 and HT40) : OFDM (64QAM, 16QAM, QPSK, BPSK)
Transfer Rate:	IEEE for 802.11b: 1Mbps/2Mbps/5.5Mbps/11Mbps IEEE for 802.11g : 6Mbps/9Mbps/12Mbps/18Mbps/24Mbps/36Mbps/48Mbps/54Mbps IEEE for 802.11n(HT20) : 6.5Mbps/13Mbps/19.5Mbps/26Mbps/39Mbps/52Mbps/58.5Mbps/65Mbps IEEE for 802.11n(HT40) : 13.5Mbps/27Mbps/40.5Mbps/54Mbps/81Mbps/108Mbps/121.5Mbps/135Mbps
Product Type:	<input type="checkbox"/> Mobile <input checked="" type="checkbox"/> Portable
Test Software of EUT:	Andriod
Antenna Type:	Metal antenna
Antenna Gain:	0.74dBi

Operation Frequency each of channel(802.11b/g/n HT20)							
Channel	Frequency	Channel	Frequency	Channel	Frequency	Channel	Frequency
1	2412MHz	4	2427MHz	7	2442MHz	10	2457MHz
2	2417MHz	5	2432MHz	8	2447MHz	11	2462MHz
3	2422MHz	6	2437MHz	9	2452MHz		
Operation Frequency each of channel(802.11n HT40)							
Channel	Frequency	Channel	Frequency	Channel	Frequency		
3	2422MHz	6	2437MHz	9	2452MHz		
4	2427MHz	7	2442MHz				
5	2432MHz	8	2447MHz				

Note:

In section 15.31(m), regards to the operating frequency range over 10 MHz, the Lowest frequency, the middle frequency, and the highest frequency of channel were selected to perform the test, and the selected channel see below:

For 802.11b/g/n (HT20):

Channel	Frequency
The Lowest channel	2412MHz
The Middle channel	2437MHz
The Highest channel	2462MHz

For 802.11n (HT40):

Channel	Frequency
The Lowest channel	2422MHz
The Middle channel	2437MHz
The Highest channel	2452MHz

Note:

Software provided by client enabled the EUT to transmit and receive data at lowest, middle and highest channel individually.

4.4 Test Environment and Mode

Operating Environment:	
Radiated Emissions:	
Temperature:	25.3 °C
Humidity:	55 % RH
Atmospheric Pressure:	1009 mbar
Conducted Emissions:	
Temperature:	25.6 °C
Humidity:	60 % RH
Atmospheric Pressure:	1009 mbar
Radio conducted item test (RF Conducted test room):	
Temperature:	25.5 °C
Humidity:	52 % RH
Atmospheric Pressure:	1009 mbar
Test mode:	
Transmitting mode:	Keep the EUT in transmitting mode with all kind of modulation and all kind of data rate.

Run Software:

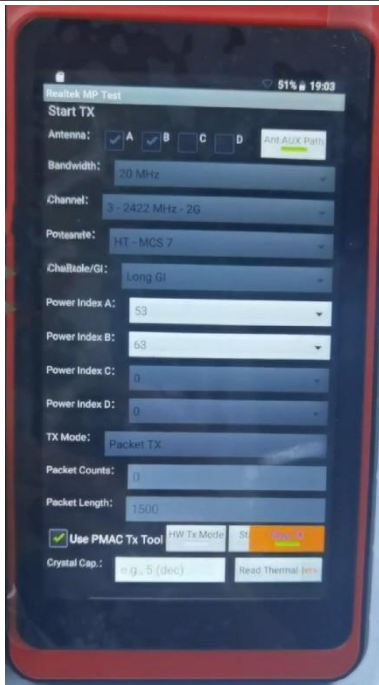

4.5 Description of Support Units

The EUT has been tested with associated equipment below.

1) Support equipment

Description	Manufacturer	Model No.	Certification	Supplied by
/	/	/	/	/

2) Cable

Cable No.	Description	Manufacturer	Cable Type/Length	Supplied by
/	/	/	/	/

4.6 Test Location

All tests were performed at:

Shenzhen Huaxia Testing Technology Co., Ltd.

1F., Block A of Tongsheng Technology Building, Huahui Road, Dalang Street, Longhua New District, Shenzhen, Guangdong, China

4.7 Test Facility

The test facility is recognized, certified, or accredited by the following organizations:

• **A2LA (Certificate No. 4742.01)**

Shenzhen Huaxia Testing Technology Co., Ltd., Shenzhen EMC Laboratory is accredited by the American Association for Laboratory Accreditation(A2LA). Certificate No. 4742.01.

• **FCC Registration No.: 522263**

Shenzhen Huaxia Testing Technology Co., Ltd., Shenzhen EMC Laboratory has been registered and fully described in a report filed with the (FCC) Federal Communications Commission. The acceptance letter from the FCC is maintained in our files. Registration No.:522263

4.8 Statement of the measurement uncertainty

The data and results referenced in this document are true and accurate.

The reader is cautioned that there may be errors within the calibration limits of the equipment and facilities.

The measurement uncertainty was calculated for all measurements listed in this test report acc. to CISPR 16 - 4 „Specification for radio disturbance and immunity measuring apparatus and methods – Part 4: Uncertainty in EMC Measurements“ and is documented in the **Shenzhen Huaxia Testing Technology Co., Ltd.** quality system acc. to DIN EN ISO/IEC 17025.

Furthermore, component and process variability of devices similar to that tested may result in additional deviation. The manufacturer has the sole responsibility of continued compliance of the device.

Hereafter the best measurement capability for CQA laboratory is reported:

No.	Item	Uncertainty	Notes
1	Radiated Emission (Below 1GHz)	5.12dB	(1)
2	Radiated Emission (Above 1GHz)	4.60dB	(1)
3	Conducted Disturbance (0.15~30MHz)	3.34dB	(1)
4	Radio Frequency	3×10^{-8}	(1)
5	Duty cycle	0.6 %.	(1)
6	Occupied Bandwidth	1.1%	(1)
7	RF conducted power	0.86dB	(1)
8	RF power density	0.74	(1)
9	Conducted Spurious emissions	0.86dB	(1)
10	Temperature test	0.8°C	(1)
11	Humidity test	2.0%	(1)
12	Supply voltages	0.5 %.	(1)
13	Frequency Error	5.5 Hz	(1)

(1)This uncertainty represents an expanded uncertainty expressed at approximately the 95% confidence level using a coverage factor of k=2.

4.9 Deviation from Standards

None.

4.10 Abnormalities from Standard Conditions

None.

4.11 Other Information Requested by the Customer

None.

4.12 Equipment List

Test Equipment	Manufacturer	Model No.	Instrument No.	Calibration Date	Calibration Due Date
EMI Test Receiver	R&S	ESR7	CQA-005	2022/09/09	2023/09/08
Spectrum analyzer	R&S	FSU26	CQA-038	2022/09/09	2023/09/08
Spectrum analyzer	R&S	FSU40	CQA-075	2022/09/09	2023/09/08
Preamplifier	MITEQ	AFS4-00010300-18-10P-4	CQA-035	2022/09/09	2023/09/08
Preamplifier	MITEQ	AMF-6D-02001800-29-20P	CQA-036	2022/09/09	2023/09/08
Preamplifier	EMCI	EMC184055SE	CQA-089	2022/09/09	2023/09/08
Loop antenna	Schwarzbeck	FMZB1516	CQA-060	2021/09/16	2024/09/15
Bilog Antenna	R&S	HL562	CQA-011	2021/09/16	2024/09/15
Horn Antenna	R&S	HF906	CQA-012	2021/09/16	2024/09/15
Horn Antenna	Schwarzbeck	BBHA 9170	CQA-088	2021/09/16	2024/09/15
Coaxial Cable (Above 1GHz)	CQA	N/A	C007	2022/09/09	2023/09/08
Coaxial Cable (Below 1GHz)	CQA	N/A	C013	2022/09/09	2023/09/08
RF cable(9KHz~40GHz)	CQA	RF-01	CQA-079	2022/09/09	2023/09/08
Antenna Connector	CQA	RFC-01	CQA-080	2022/09/09	2023/09/08
Power Sensor	KEYSIGHT	U2021XA	CQA-30	2022/09/09	2023/09/08
N1918A Power Analysis Manager Power Panel	Agilent	N1918A	CQA-074	2022/09/09	2023/09/08
Power meter	R&S	NRVD	CQA-029	2022/09/09	2023/09/08
Power divider	MIDWEST	PWD-2533-02-SMA-79	CQA-067	2022/09/09	2023/09/08
EMI Test Receiver	R&S	ESR7	CQA-005	2022/09/09	2023/09/08
LISN	R&S	ENV216	CQA-003	2022/09/09	2023/09/08
Coaxial cable	CQA	N/A	CQA-C009	2022/09/09	2023/09/08
DC power	KEYSIGHT	E3631A	CQA-028	2022/09/09	2023/09/08

Test software:

	Manufacturer	Software brand
Radiated Emissions test software	Tonscend	JS1120-3
Conducted Emissions test software	Audix	e3
RF Conducted test software	Audix	e3

5 Test results and Measurement Data

5.1 Antenna Requirement

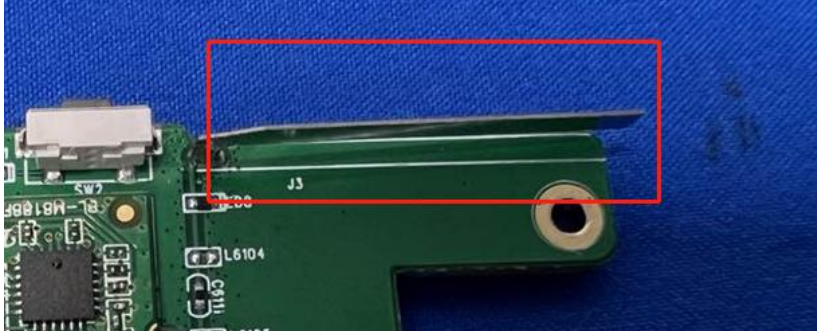
Standard requirement:	47 CFR Part 15C Section 15.203 /247(c)
<p>15.203 requirement: An intentional radiator shall be designed to ensure that no antenna other than that furnished by the responsible party shall be used with the device. The use of a permanently attached antenna or of an antenna that uses a unique coupling to the intentional radiator, the manufacturer may design the unit so that a broken antenna can be replaced by the user, but the use of a standard antenna jack or electrical connector is prohibited.</p> <p>15.247(b) (4) requirement: The conducted output power limit specified in paragraph (b) of this section is based on the use of antennas with directional gains that do not exceed 6 dBi. Except as shown in paragraph (c) of this section, if transmitting antennas of directional gain greater than 6 dBi are used, the conducted output power from the intentional radiator shall be reduced below the stated values in paragraphs (b)(1), (b)(2), and (b)(3) of this section, as appropriate, by the amount in dB that the directional gain of the antenna exceeds 6 dBi.</p>	
EUT Antenna:	
<p>The antenna is Metal antenna. The best case gain of the antenna is 0.74 dBi.</p>	

5.2 Conducted Emissions

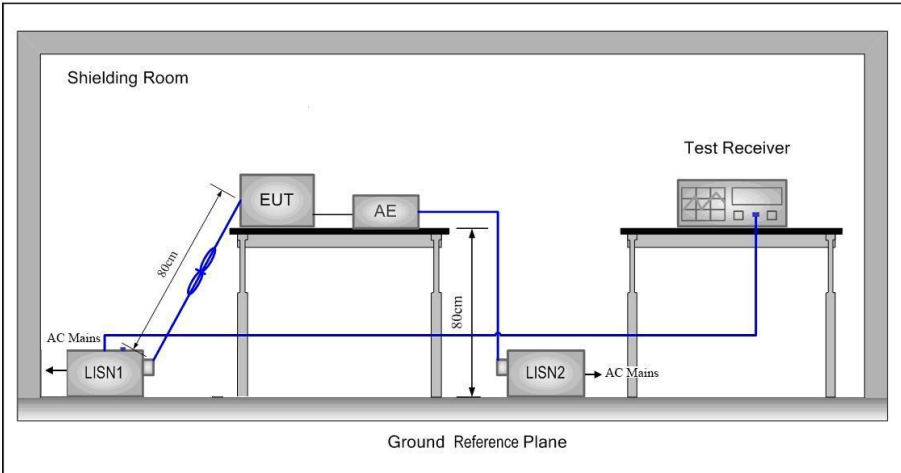
Test Requirement:	47 CFR Part 15C Section 15.207														
Test Method:	ANSI C63.10: 2013														
Test Frequency Range:	150kHz to 30MHz														
Limit:	<table border="1"> <thead> <tr> <th rowspan="2">Frequency range (MHz)</th> <th colspan="2">Limit (dBuV)</th> </tr> <tr> <th>Quasi-peak</th> <th>Average</th> </tr> </thead> <tbody> <tr> <td>0.15-0.5</td> <td>66 to 56*</td> <td>56 to 46*</td> </tr> <tr> <td>0.5-5</td> <td>56</td> <td>46</td> </tr> <tr> <td>5-30</td> <td>60</td> <td>50</td> </tr> </tbody> </table>	Frequency range (MHz)	Limit (dBuV)		Quasi-peak	Average	0.15-0.5	66 to 56*	56 to 46*	0.5-5	56	46	5-30	60	50
	Frequency range (MHz)		Limit (dBuV)												
		Quasi-peak	Average												
	0.15-0.5	66 to 56*	56 to 46*												
	0.5-5	56	46												
5-30	60	50													
* Decreases with the logarithm of the frequency.															
Test Procedure:	<ol style="list-style-type: none"> 1) The mains terminal disturbance voltage test was conducted in a shielded room. 2) The EUT was connected to AC power source through a LISN 1 (Line Impedance Stabilization Network) which provides a $50\Omega/50\mu\text{H} + 5\Omega$ linear impedance. The power cables of all other units of the EUT were connected to a second LISN 2, which was bonded to the ground reference plane in the same way as the LISN 1 for the unit being measured. A multiple socket outlet strip was used to connect multiple power cables to a single LISN provided the rating of the LISN was not exceeded. 3) The tabletop EUT was placed upon a non-metallic table 0.8m above the ground reference plane. And for floor-standing arrangement, the EUT was placed on the horizontal ground reference plane, 4) The test was performed with a vertical ground reference plane. The rear of the EUT shall be 0.4 m from the vertical ground reference plane. The vertical ground reference plane was bonded to the horizontal ground reference plane. The LISN 1 was placed 0.8 m from the boundary of the unit under test and bonded to a ground reference plane for LISNs mounted on top of the ground reference plane. This distance was between the closest points of the LISN 1 and the EUT. All other units of the EUT and associated equipment was at least 0.8 m from the LISN 2. 5) In order to find the maximum emission, the relative positions of equipment and all of the interface cables must be changed according to ANSI C63.10: 2013 on conducted measurement. 														
Test Setup:															

Exploratory Test Mode:	Transmitting with all kind of modulations, data rates at lowest, middle and highest channel.
Final Test Mode:	Through Pre-scan, find the 1Mbps of rate of 802.11b at middle channel is the worst case. Only the worst case is recorded in the report.
Test Voltage:	AC120V/60Hz
Test Results:	Pass

Measurement Data

Live Line:

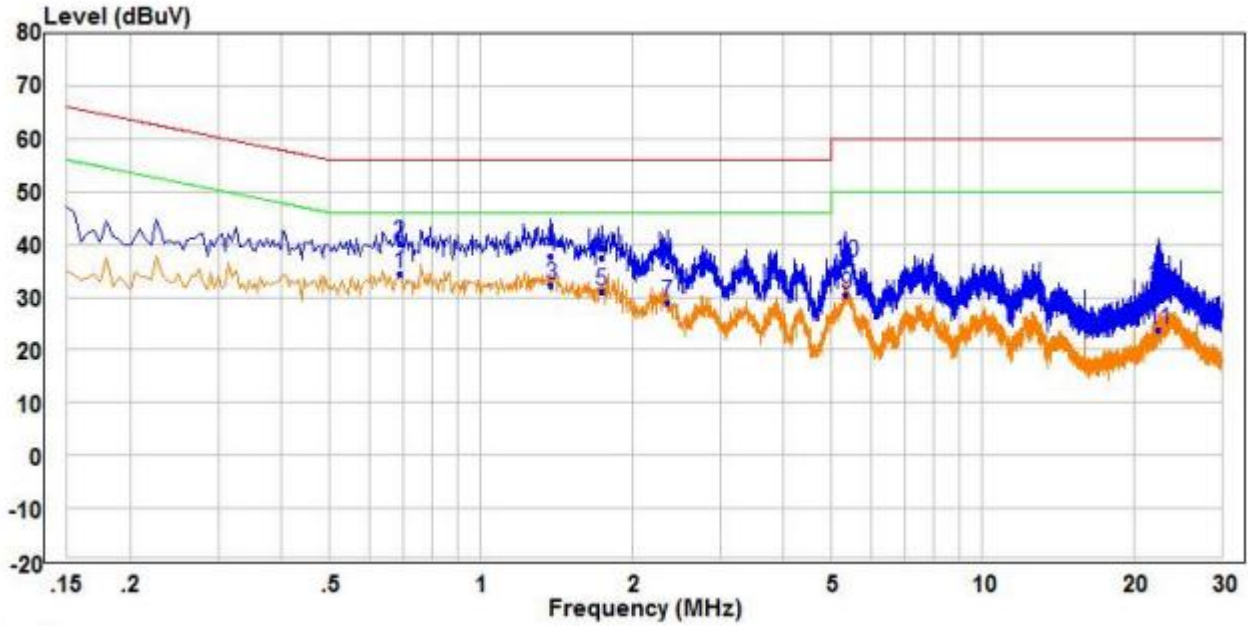

	Freq.	Read Level	Factor	Level	Limit Line	Over Limit	Remark	Pol/Phase
	dBuV	dBuV	dBuV	dBuV	dBuV	dBuV		
1	0.69	24.38	9.60	34.27	46.00	-11.73	Average	Line
2	0.69	30.29	9.60	40.18	56.00	-15.82	QP	Line
3	1.38	21.62	10.48	32.22	46.00	-13.78	Average	Line
4	1.38	27.18	10.48	37.78	56.00	-18.22	QP	Line
5	1.74	19.67	11.12	30.93	46.00	-15.07	Average	Line
6	1.74	26.06	11.12	37.32	56.00	-18.68	QP	Line
7	2.36	17.78	11.13	29.08	46.00	-16.92	Average	Line
8	2.36	24.68	11.13	35.98	56.00	-20.02	QP	Line
9	5.35	20.81	9.49	30.57	50.00	-19.43	Average	Line
10	5.35	26.76	9.49	36.52	60.00	-23.48	QP	Line
11	22.44	13.97	9.78	23.92	50.00	-26.08	Average	Line
12	22.44	21.98	9.78	31.93	60.00	-28.07	QP	Line

Remark:

1. The following Quasi-Peak and Average measurements were performed on the EUT:
2. Final Test Level = Receiver Reading + LISN Factor + Cable Loss.
3. If the Peak value under Average limit, the Average value is not recorded in the report.

Neutral Line:

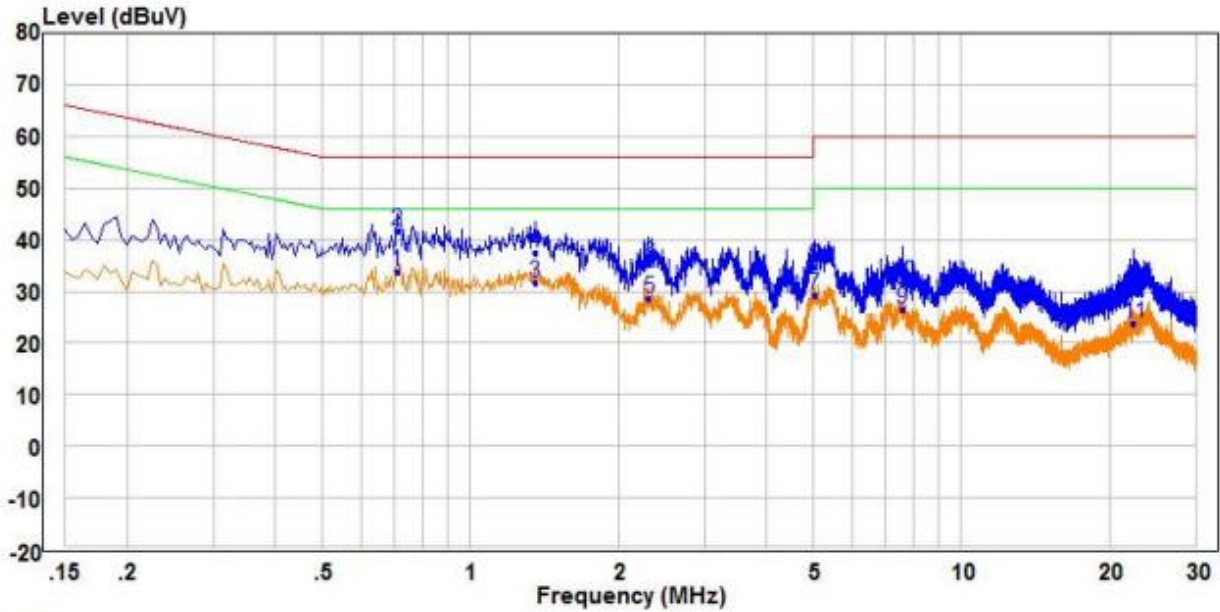

	Freq.	Read Level	Factor	Level	Limit Line	Over Limit	Remark	Pol/Phase
	dBuV	dBuV	dBuV	dBuV	dBuV	dBuV		
1	0.71	23.88	9.60	33.77	46.00	-12.23	Average	Neutral
2	0.71	31.86	9.60	41.75	56.00	-14.25	QP	Neutral
3	1.36	22.10	9.60	31.82	46.00	-14.18	Average	Neutral
4	1.36	27.81	9.60	37.53	56.00	-18.47	QP	Neutral
5	2.31	18.73	9.59	28.49	46.00	-17.51	Average	Neutral
6	2.31	25.69	9.59	35.45	56.00	-20.55	QP	Neutral
7	5.03	19.36	9.52	29.18	50.00	-20.82	Average	Neutral
8	5.03	24.81	9.52	34.63	60.00	-25.37	QP	Neutral
9	7.60	16.56	9.70	26.38	50.00	-23.62	Average	Neutral
10	7.60	21.78	9.70	31.60	60.00	-28.40	QP	Neutral
11	22.44	13.98	9.78	23.93	50.00	-26.07	Average	Neutral
12	22.44	20.35	9.78	30.30	60.00	-29.70	QP	Neutral

Remark:

1. The following Quasi-Peak and Average measurements were performed on the EUT:
2. Final Test Level = Receiver Reading + LISN Factor + Cable Loss.
3. If the Peak value under Average limit, the Average value is not recorded in the report.

5.3 Conducted Peak & Average Output Power

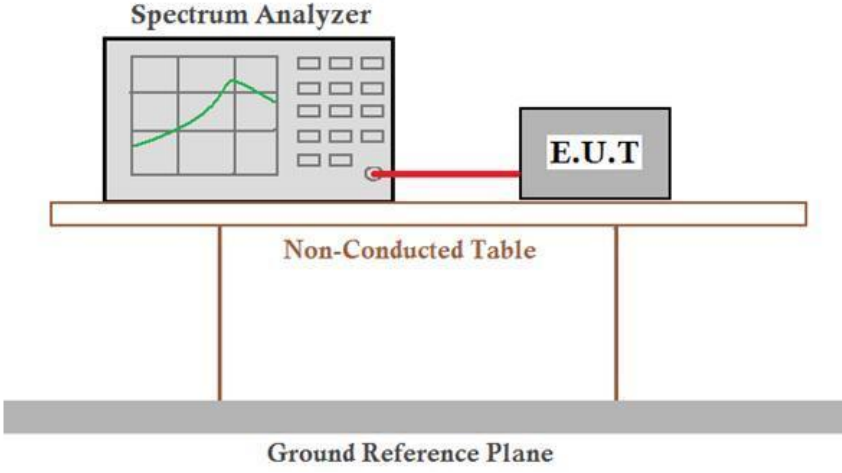
Test Requirement:	47 CFR Part 15C Section 15.247 (b)(3)
Test Method:	ANSI C63.10: 2013
Test Setup:	 <p>The diagram illustrates the test setup. A Spectrum Analyzer is connected to an E.U.T. (Equipment Under Test) via a red cable. Both the Spectrum Analyzer and the E.U.T. are placed on a Non-Conducted Table. The table is supported by a Ground Reference Plane.</p>
Exploratory Test Mode:	Transmitting with all kind of modulations, data rates
Final Test Mode:	Through Pre-scan, find the 1Mbps of rate is the worst case of 802.11b; 6Mbps of rate is the worst case of 802.11g; 6.5Mbps of rate is the worst case of 802.11n(HT20); 13.5Mbps of rate is the worst case of 802.11n(HT40). Only the worst case is recorded in the report.
Limit:	30dBm
Test Results:	Pass

Test Result

TestMode	Antenna	Channel	Result[dBm]	Limit[dBm]	Verdict
11B	Ant1	2412	0.25	≤30	PASS
		2437	2.86	≤30	PASS
		2462	2.61	≤30	PASS
11G	Ant1	2412	0.68	≤30	PASS
		2437	2.76	≤30	PASS
		2462	2.73	≤30	PASS
11N20SISO	Ant1	2412	0.99	≤30	PASS
		2437	2.97	≤30	PASS
		2462	2.99	≤30	PASS
11N40SISO	Ant1	2422	1.68	≤30	PASS
		2437	2.14	≤30	PASS
		2452	2.51	≤30	PASS

Test Graphs

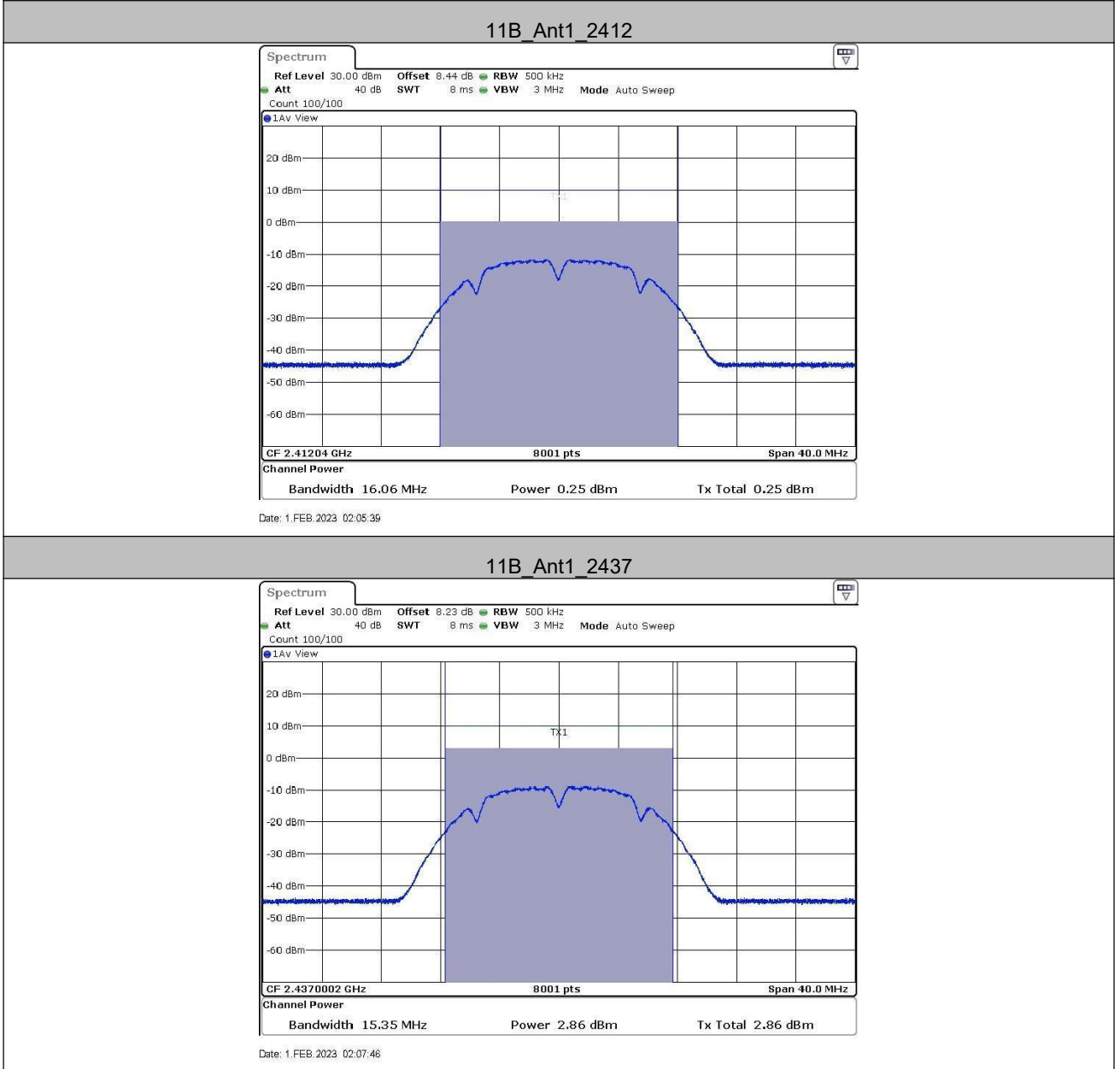



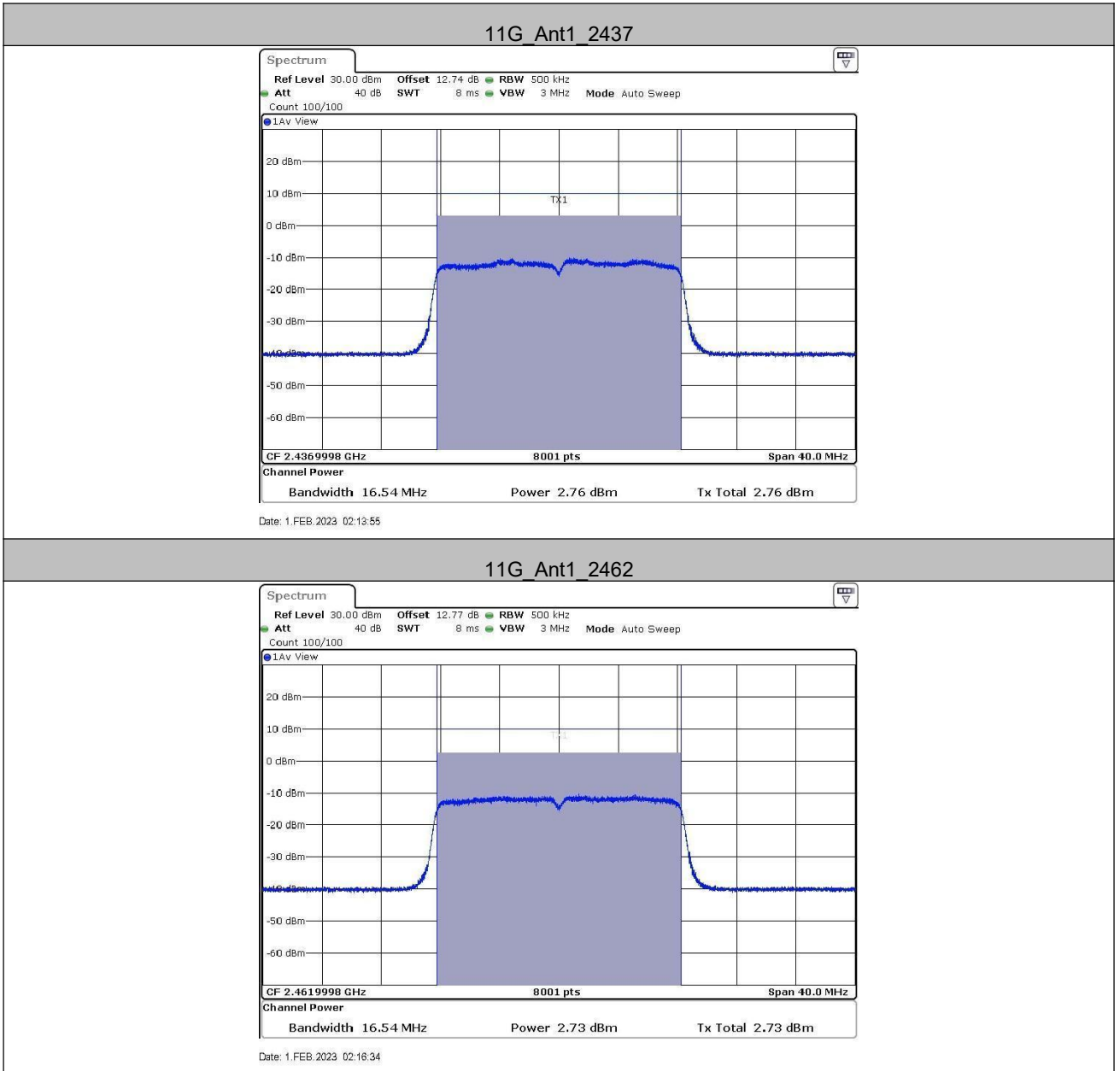

11N20SISO_Ant1_2412

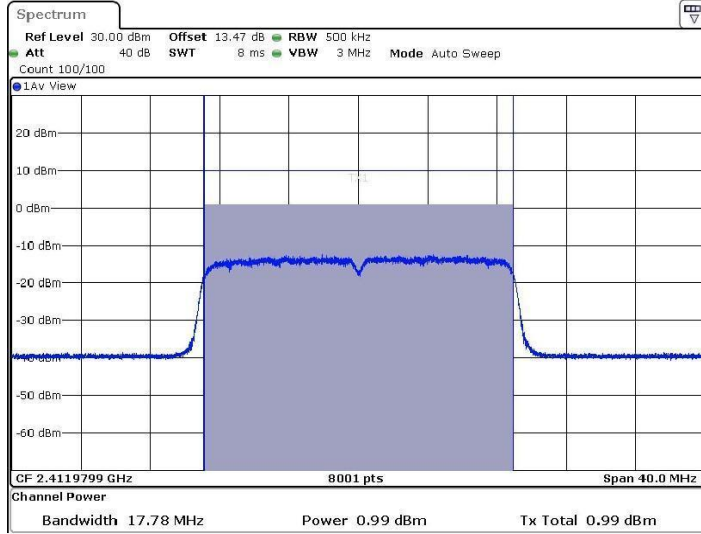

Date: 1.FEB.2023 02:18:30

11N20SISO_Ant1_2437

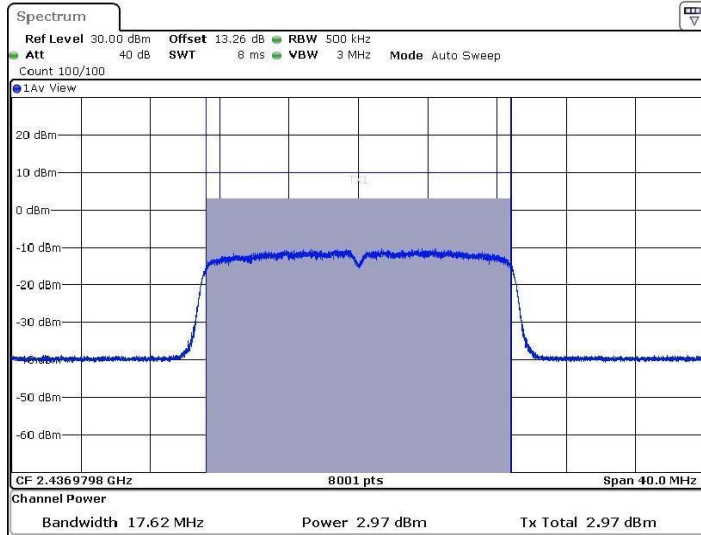

Date: 1.FEB.2023 02:21:22

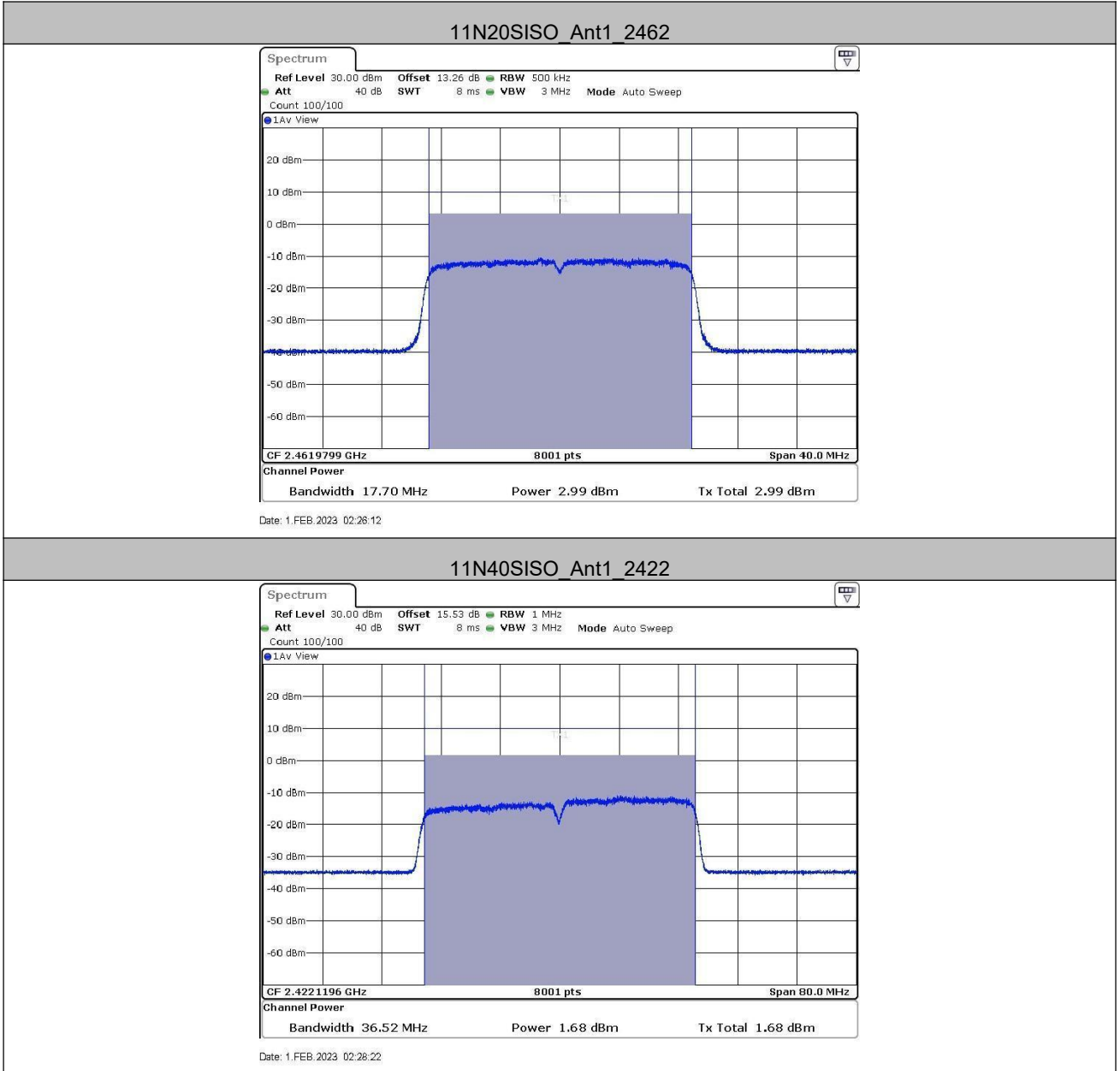

11N40SISO_Ant1_2437

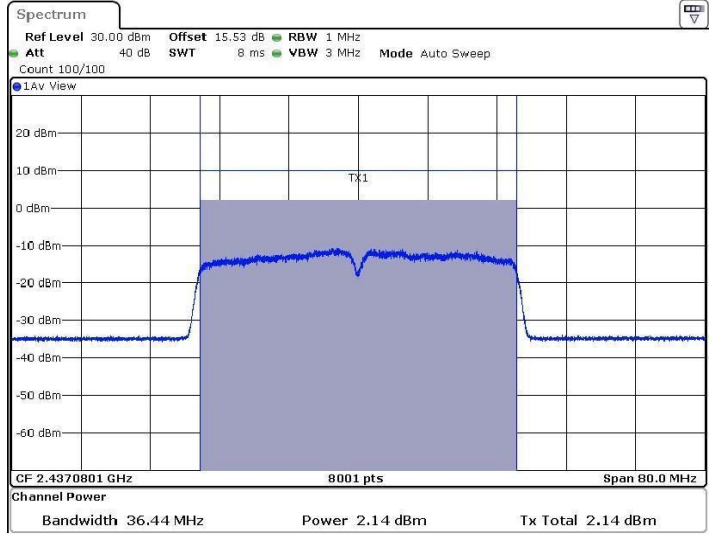

Date: 1.FEB.2023 02:30:35

11N40SISO_Ant1_2452

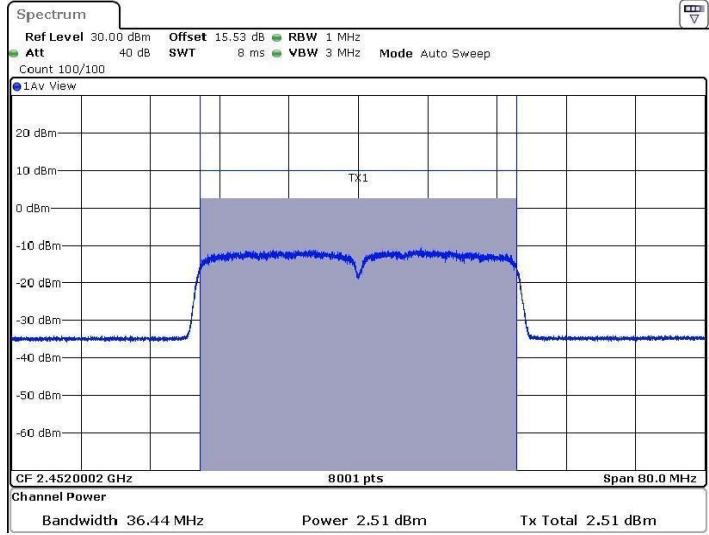

Date: 1.FEB.2023 02:33:39

5.4 6dB Occupy Bandwidth

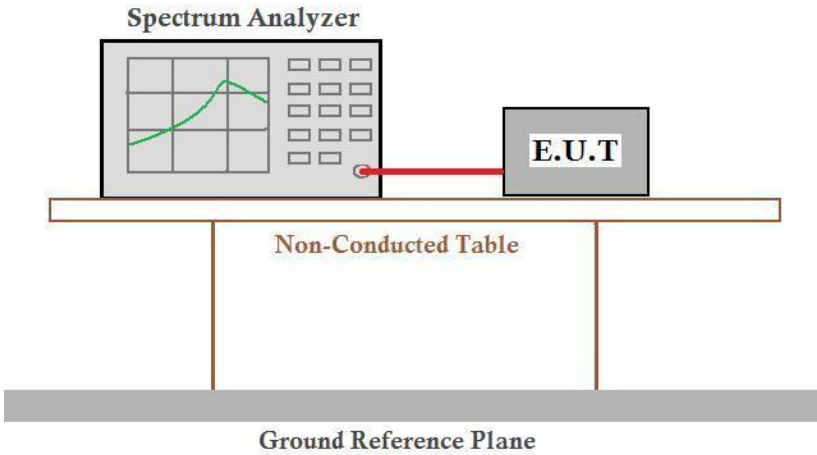
Test Requirement:	47 CFR Part 15C Section 15.247 (a)(2)
Test Method:	ANSI C63.10: 2013
Test Setup:	 <p style="text-align: center;">Offset=cable loss+ attenuation factor</p>
Exploratory Test Mode:	Transmitting with all kind of modulations, data rates
Final Test Mode:	Through Pre-scan, find the 1Mbps of rate is the worst case of 802.11b; 6Mbps of rate is the worst case of 802.11g; 6.5Mbps of rate is the worst case of 802.11n(HT20); 13.5Mbps of rate is the worst case of 802.11n(HT40). Only the worst case is recorded in the report.
Limit:	≥ 500 kHz
Test Results:	Pass

Test Result

TestMode	Antenna	Channel	DTS BW [MHz]	FL[MHz]	FH[MHz]	Limit[MHz]	Verdict
11B	Ant1	2412	12.04	2405.96	2418.00	0.5	PASS
		2437	10.12	2431.92	2442.04	0.5	PASS
		2462	10.12	2456.92	2467.04	0.5	PASS
11G	Ant1	2412	16.32	2403.84	2420.16	0.5	PASS
		2437	16.32	2428.84	2445.16	0.5	PASS
		2462	16.40	2453.80	2470.20	0.5	PASS
11N20SISO	Ant1	2412	17.00	2403.76	2420.76	0.5	PASS
		2437	16.96	2428.64	2445.60	0.5	PASS
		2462	17.60	2453.20	2470.80	0.5	PASS
11N40SISO	Ant1	2422	36.08	2404.16	2440.24	0.5	PASS
		2437	33.68	2421.16	2454.84	0.5	PASS
		2452	35.76	2434.16	2469.92	0.5	PASS

Test Graphs



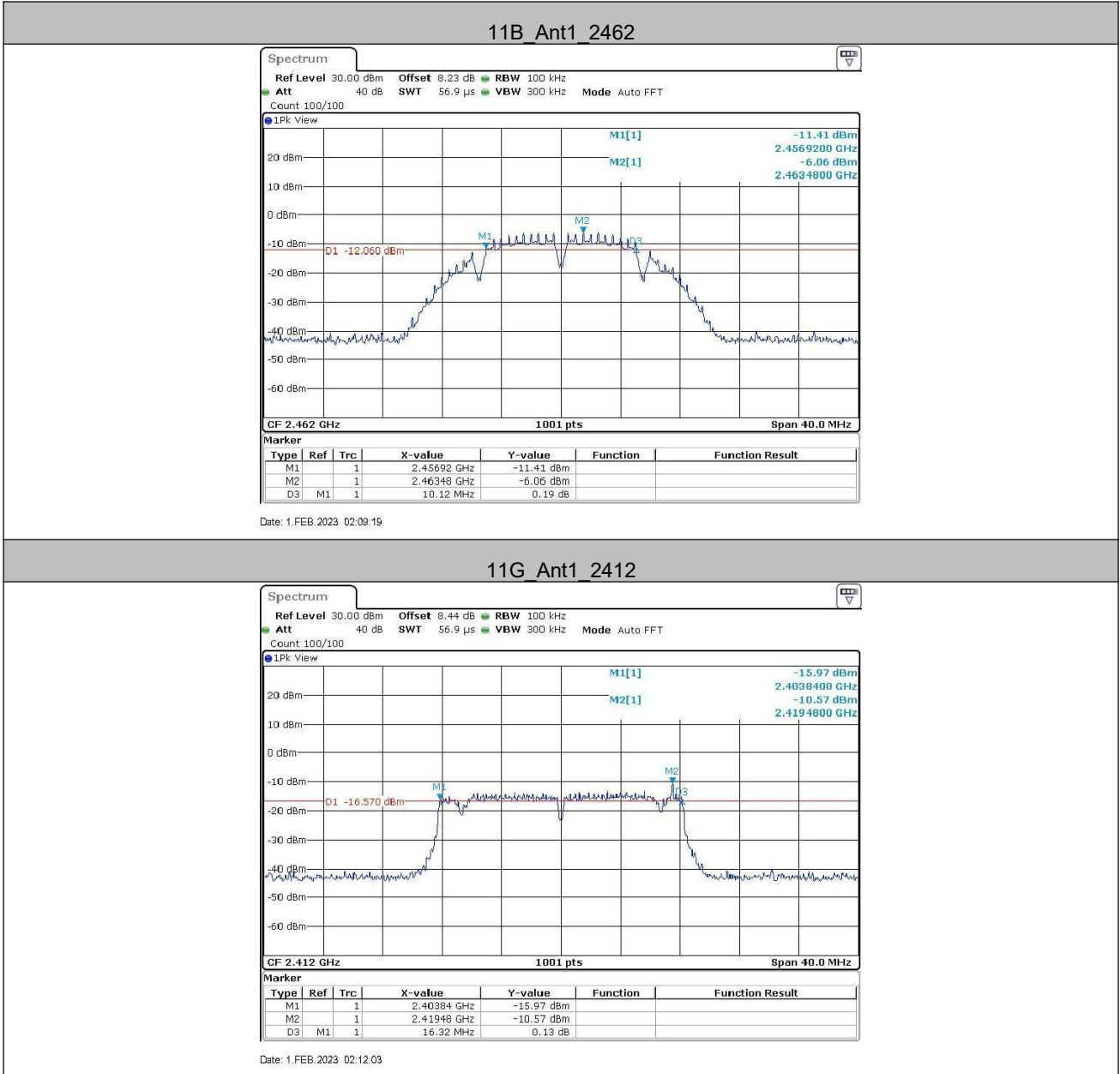

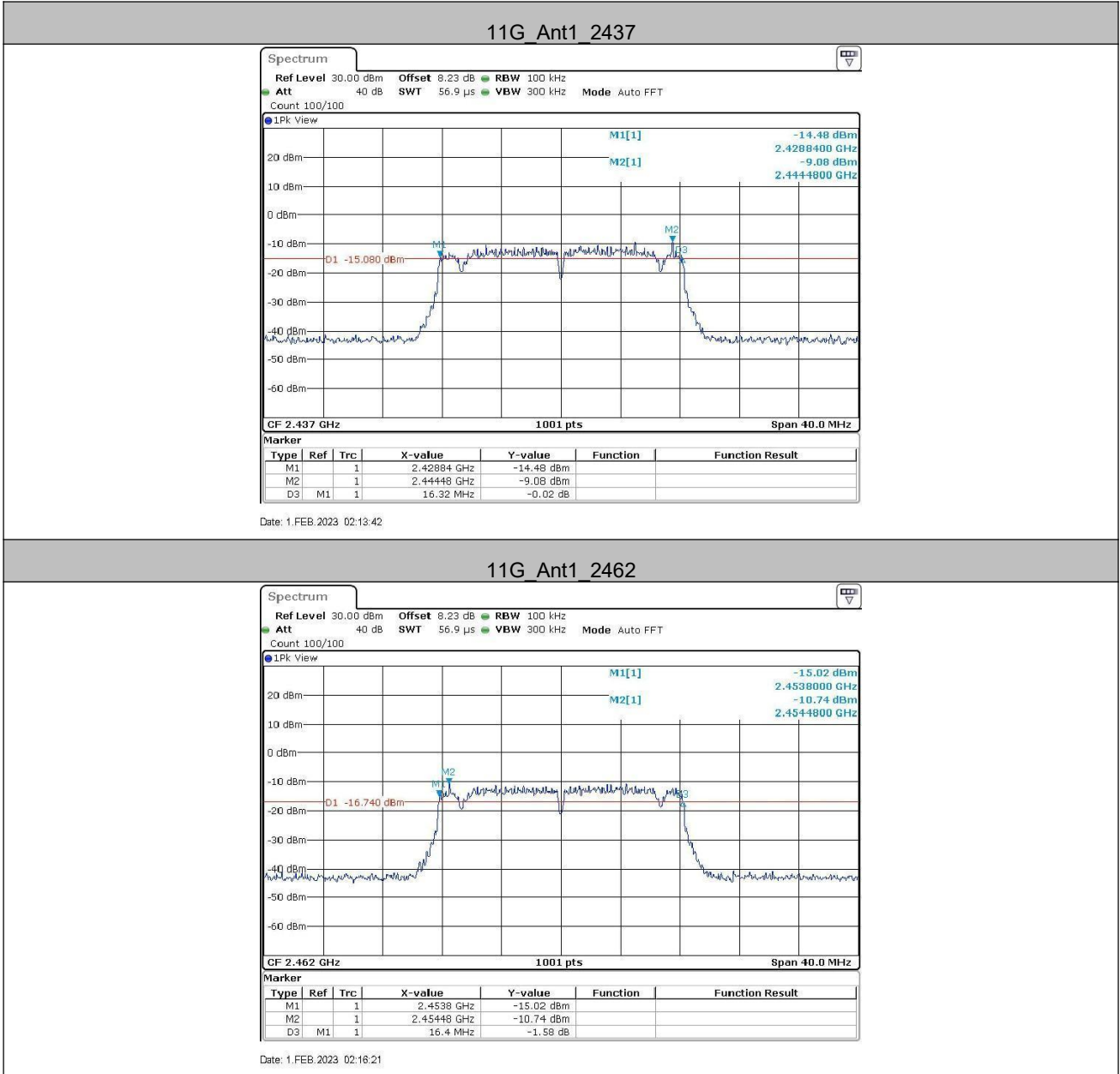

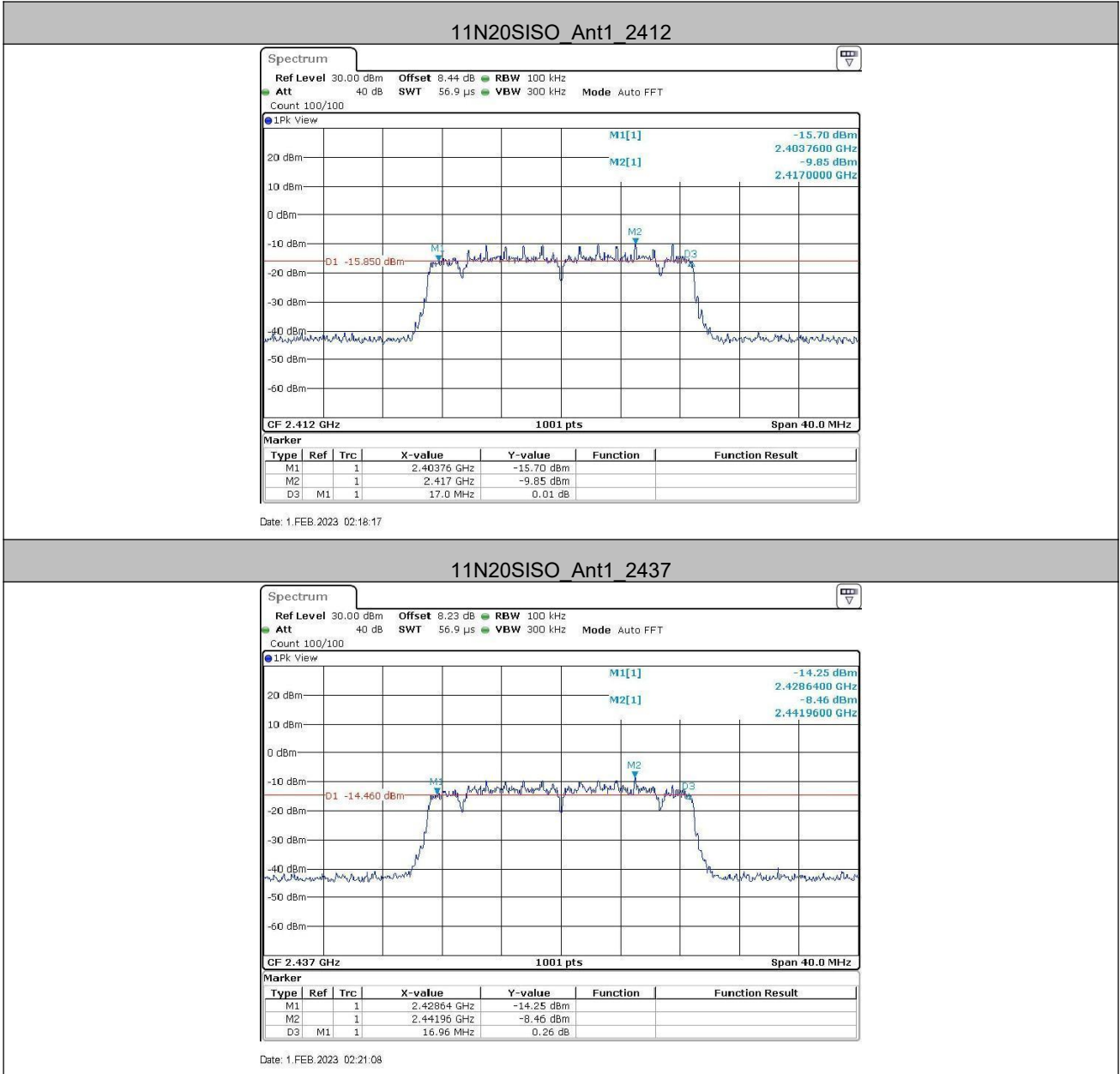

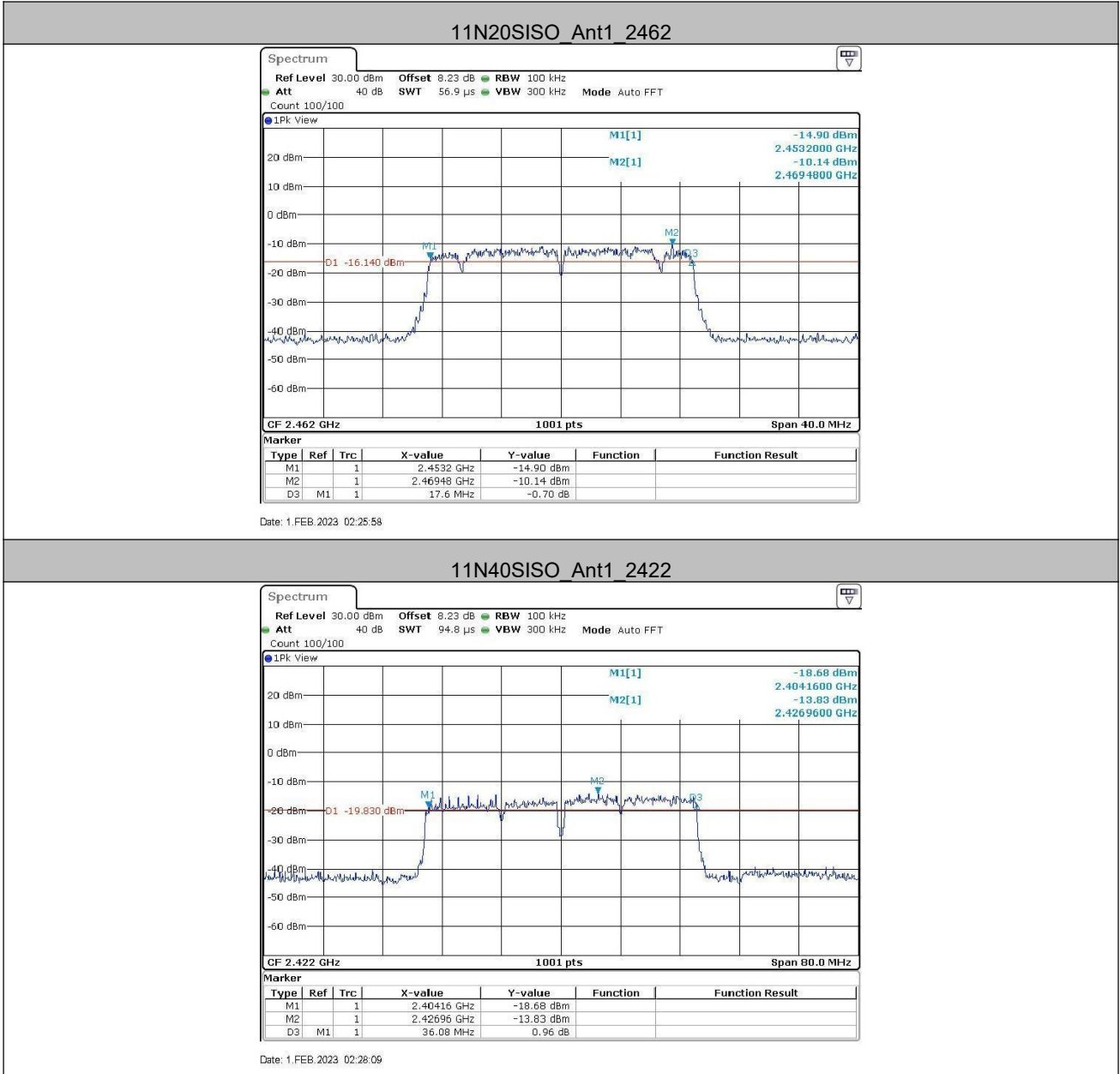

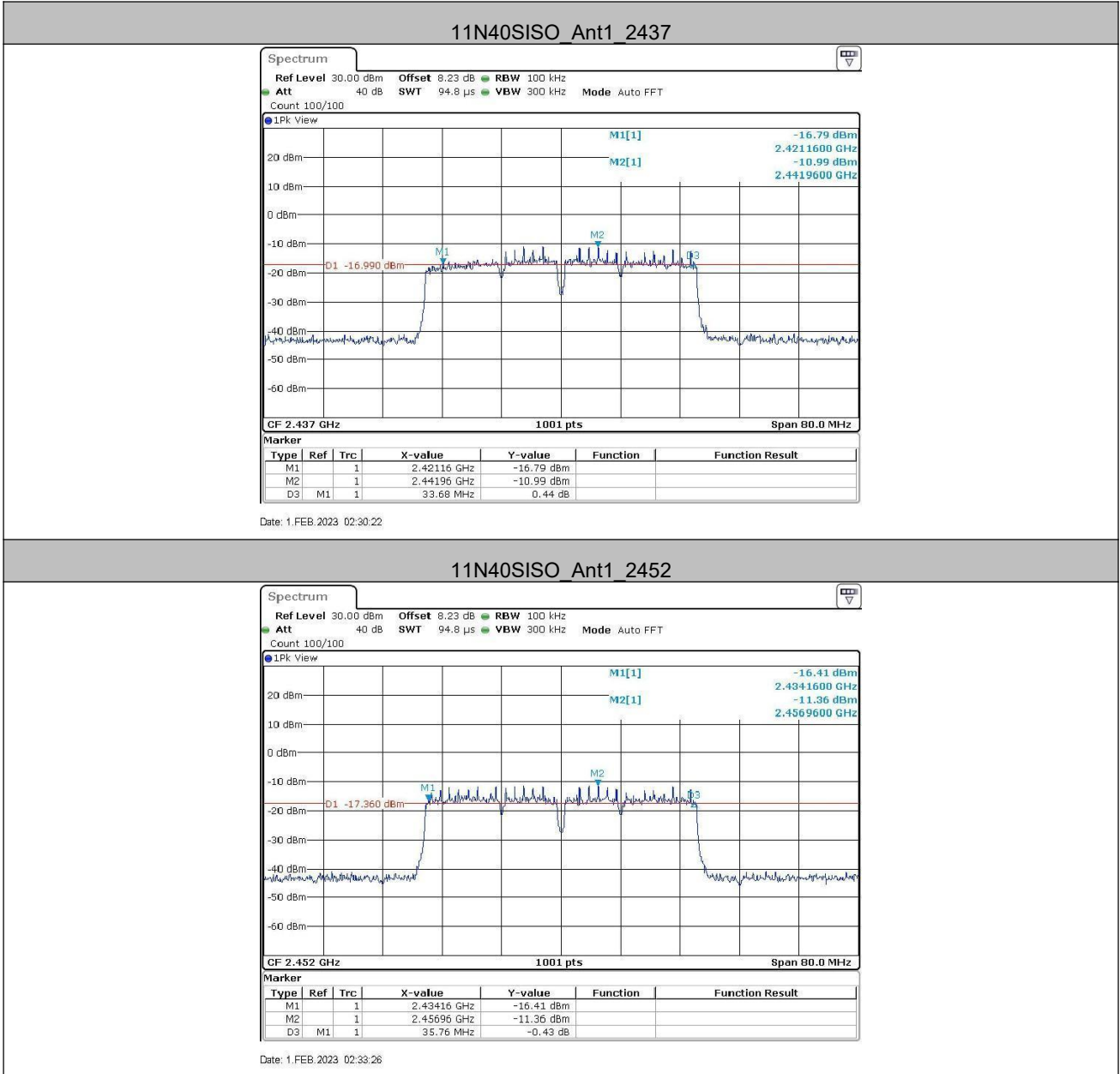

5.5 Power Spectral Density

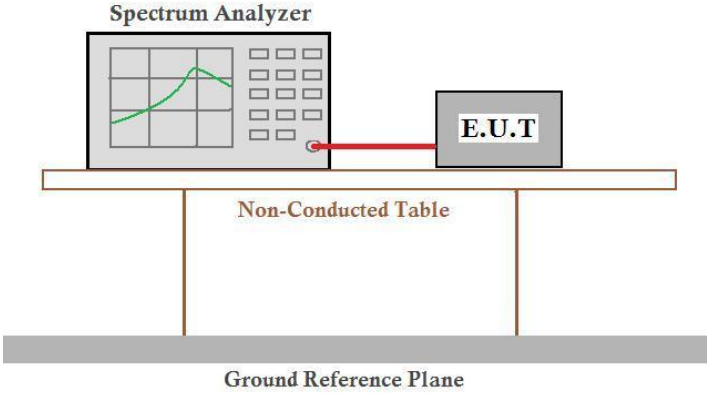
Test Requirement:	47 CFR Part 15C Section 15.247 (e)
Test Method:	ANSI C63.10: 2013
Test Setup:	 <p>Offset=cable loss+ attenuation factor</p>
Exploratory Test Mode:	Transmitting with all kind of modulations, data rates
Final Test Mode:	Through Pre-scan, find the 1Mbps of rate is the worst case of 802.11b; 6Mbps of rate is the worst case of 802.11g; 6.5Mbps of rate is the worst case of 802.11n(HT20); 13.5Mbps of rate is the worst case of 802.11n(HT40). Only the worst case is recorded in the report.
Limit:	$\leq 8.00\text{dBm}/3\text{kHz}$
Test Results:	Pass

Test Result

TestMode	Antenna	Channel	Result[dBm/3-100kHz]	Limit[dBm/3kHz]	Verdict
11B	Ant1	2412	-31.86	≤8	PASS
		2437	-28.64	≤8	PASS
		2462	-29.24	≤8	PASS
11G	Ant1	2412	-30.97	≤8	PASS
		2437	-28.17	≤8	PASS
		2462	-28.87	≤8	PASS
11N20SISO	Ant1	2412	-31.12	≤8	PASS
		2437	-28.31	≤8	PASS
		2462	-29.51	≤8	PASS
11N40SISO	Ant1	2422	-30.82	≤8	PASS
		2437	-30.09	≤8	PASS
		2452	-29.19	≤8	PASS

Test Graphs

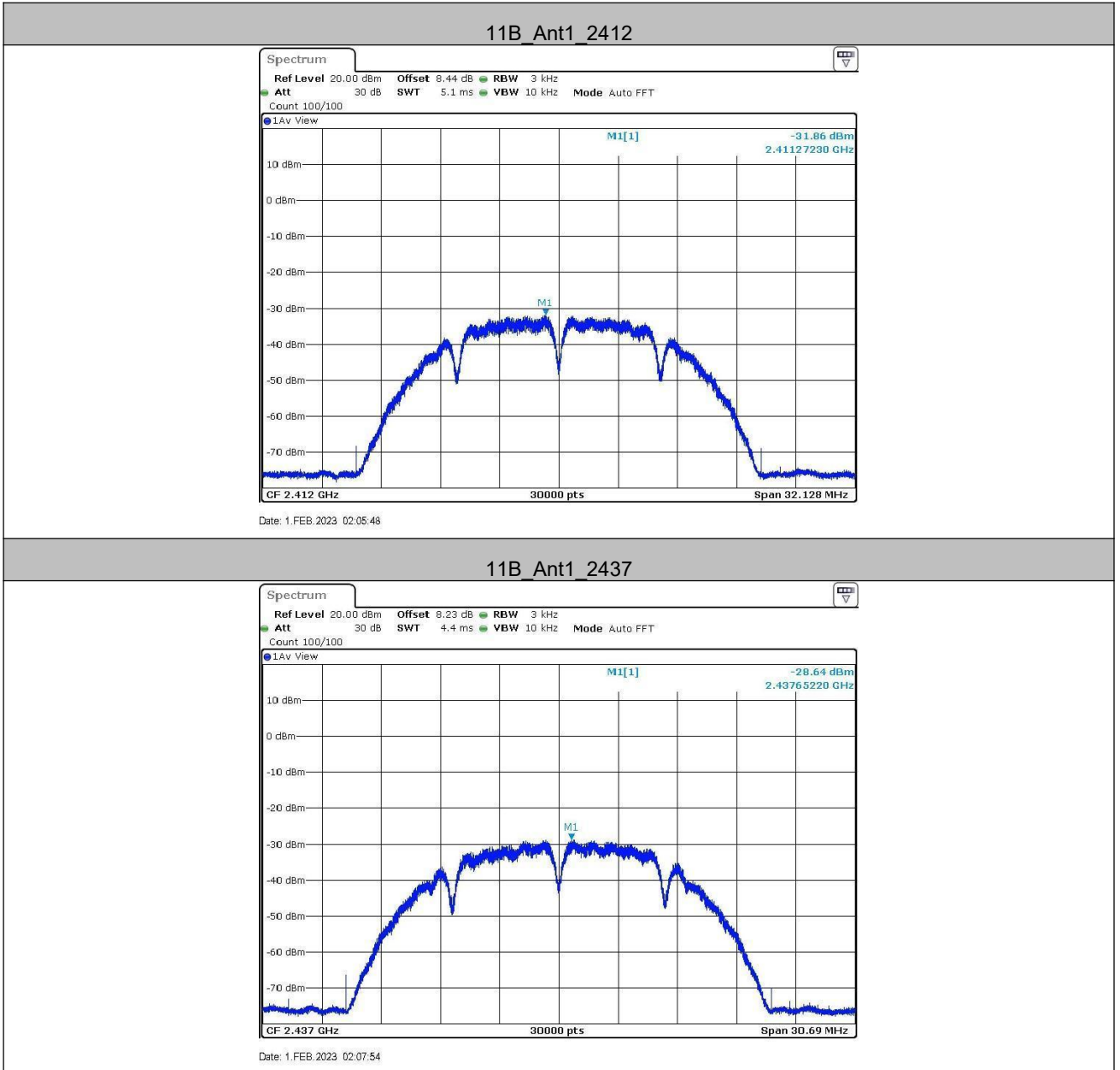

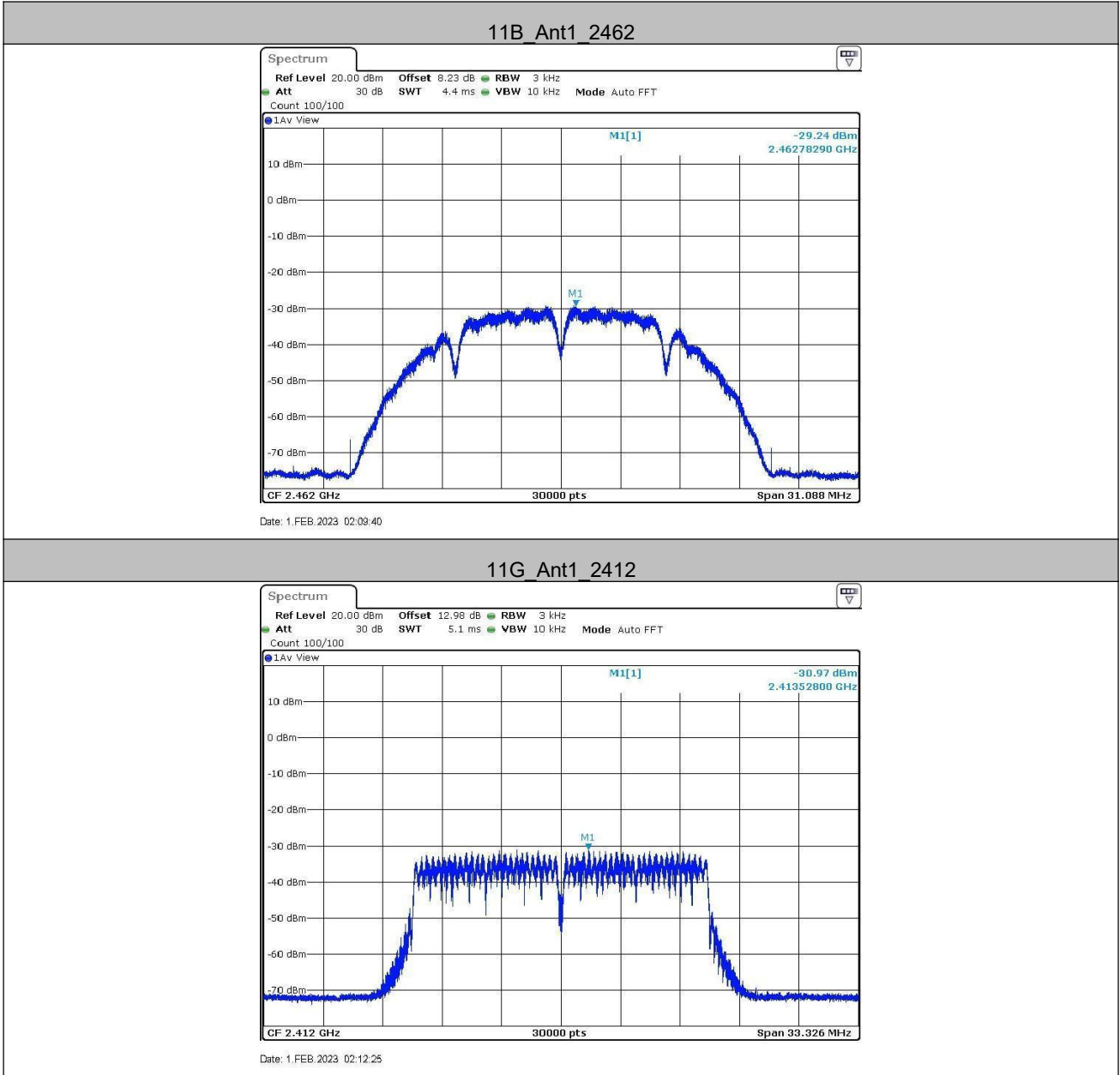

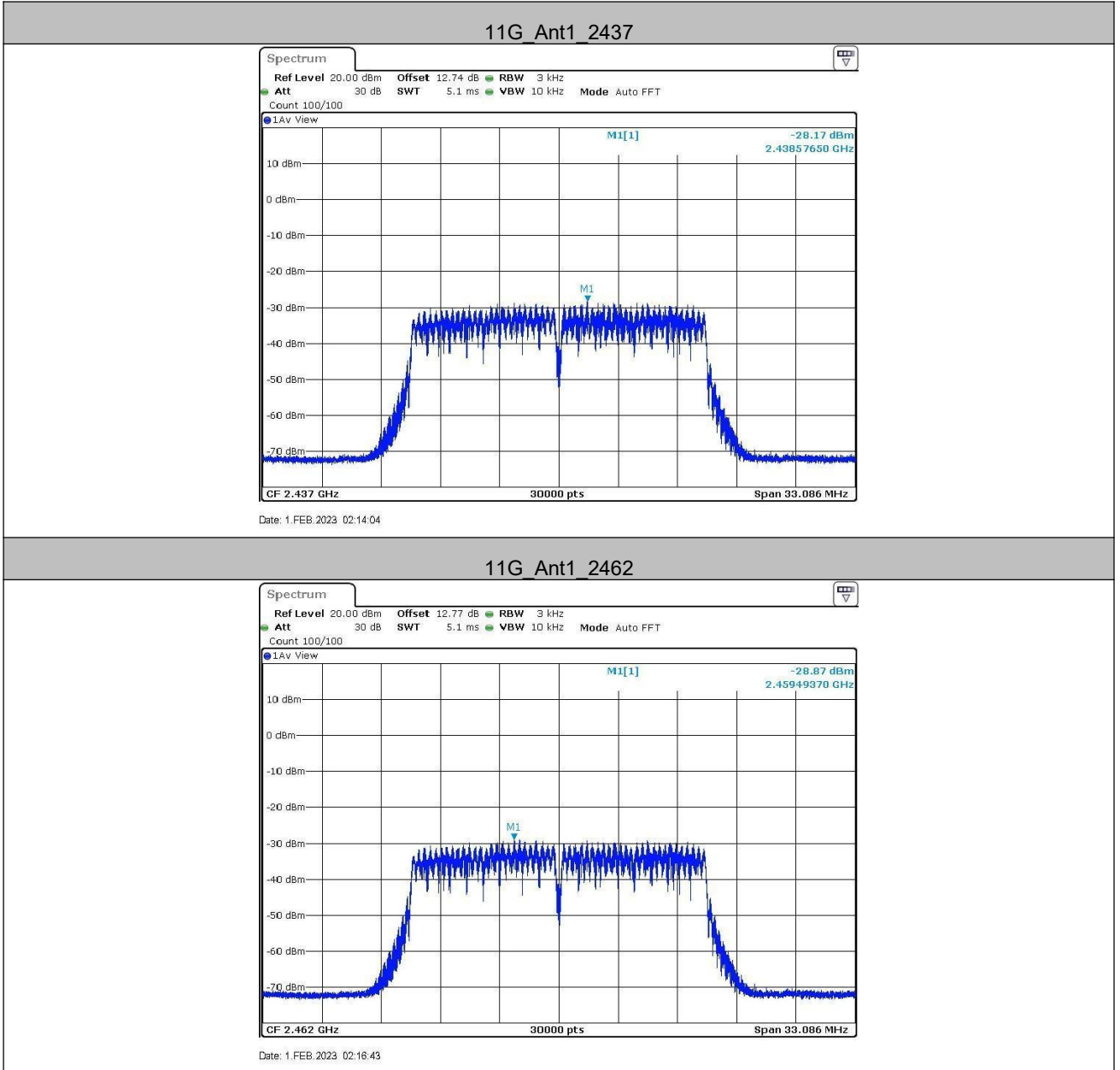

11N20SISO_Ant1_2412

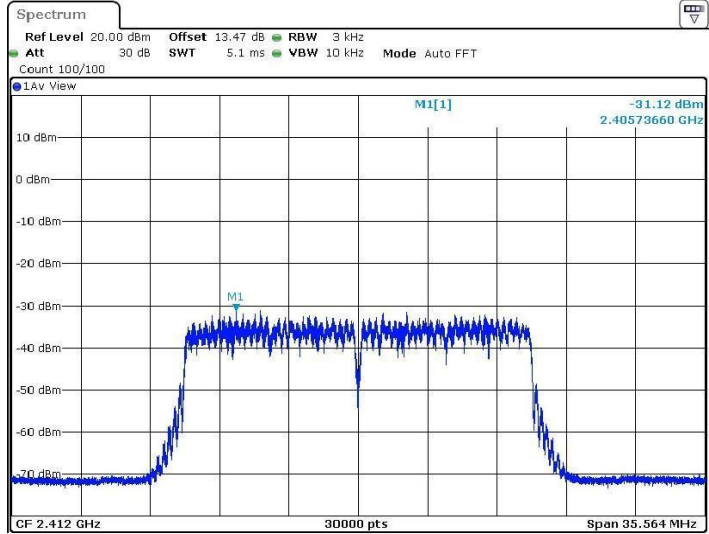

Date: 1.FEB.2023 02:18:38

11N20SISO_Ant1_2437

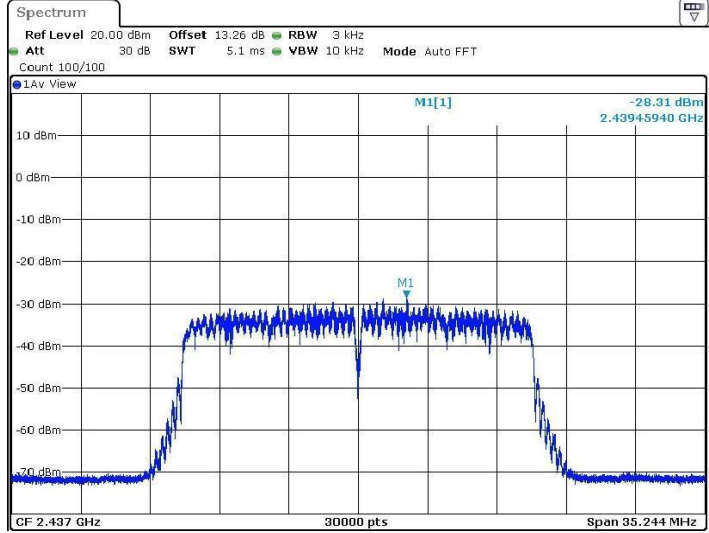

Date: 1.FEB.2023 02:21:30

11N20SISO Ant1_2462

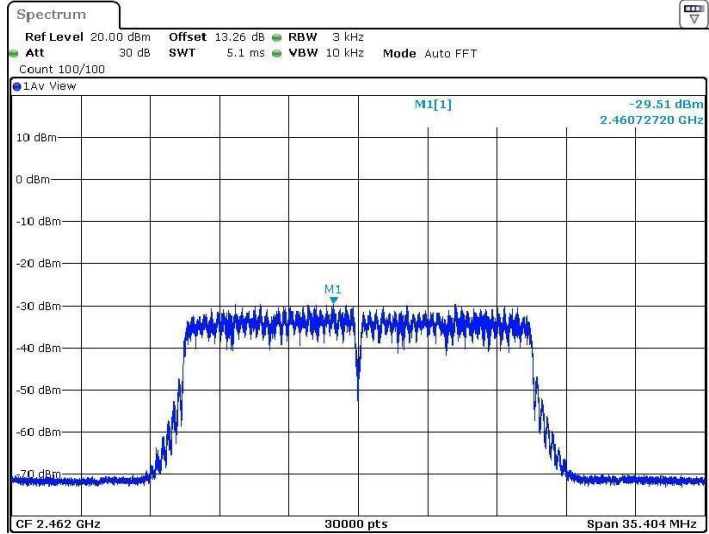

Date: 1.FEB.2023 02:28:20

11N40SISO Ant1_2422

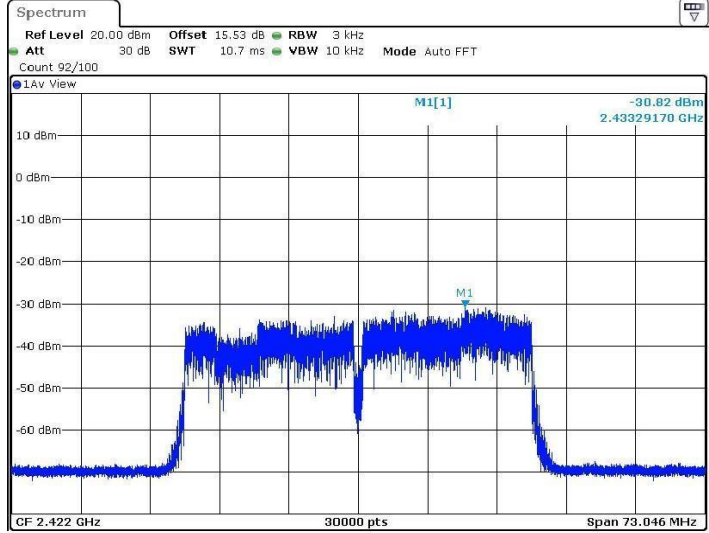

Date: 1.FEB.2023 02:28:30

11N40SISO_Ant1_2437

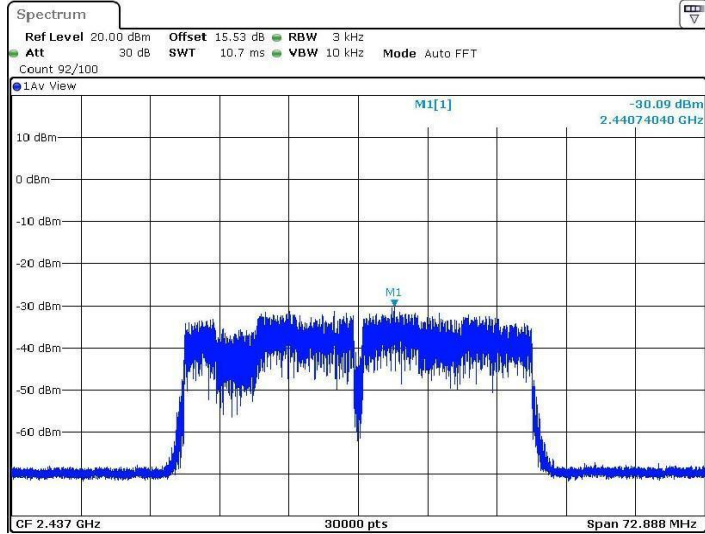

11N40SISO_Ant1_2452

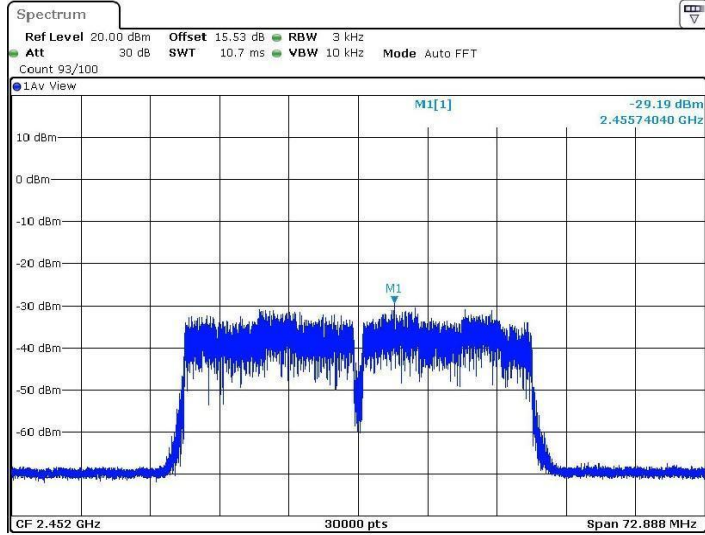

5.6 Band-edge for RF Conducted Emissions

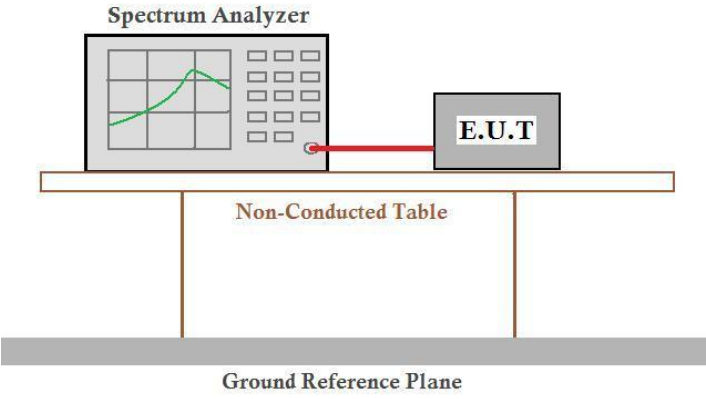
Test Requirement:	47 CFR Part 15C Section 15.247 (d)
Test Method:	ANSI C63.10: 2013
Test Setup:	 <p>Offset=cable loss+ attenuation factor</p>
Exploratory Test Mode:	Transmitting with all kind of modulations, data rates
Final Test Mode:	Through Pre-scan, find the 1Mbps of rate is the worst case of 802.11b; 6Mbps of rate is the worst case of 802.11g; 6.5Mbps of rate is the worst case of 802.11n(HT20); 13.5Mbps of rate is the worst case of 802.11n(HT40). Only the worst case is recorded in the report.
Limit:	In any 100 kHz bandwidth outside the frequency band in which the spread spectrum intentional radiator is operating, the radio frequency power that is produced by the intentional radiator shall be at least 20 dB below that in the 100 kHz bandwidth within the band that contains the highest level of the desired power, based on either an RF conducted or a radiated measurement.
Test Results:	Pass

Test Result

TestMode	Antenna	ChName	Channel	RefLevel[dBm]	Result[dBm]	Limit[dBm]	Verdict
11B	Ant1	Low	2412	-9.02	-49.55	≤-39.02	PASS
		High	2462	-6.98	-49.04	≤-36.98	PASS
11G	Ant1	Low	2412	-11.84	-48.84	≤-41.84	PASS
		High	2462	-10.81	-48.59	≤-40.81	PASS
11N20SISO	Ant1	Low	2412	-10.08	-50.23	≤-40.08	PASS
		High	2462	-8.78	-48.71	≤-38.78	PASS
11N40SISO	Ant1	Low	2422	-11.70	-50.53	≤-41.7	PASS
		High	2452	-11.24	-48.7	≤-41.24	PASS

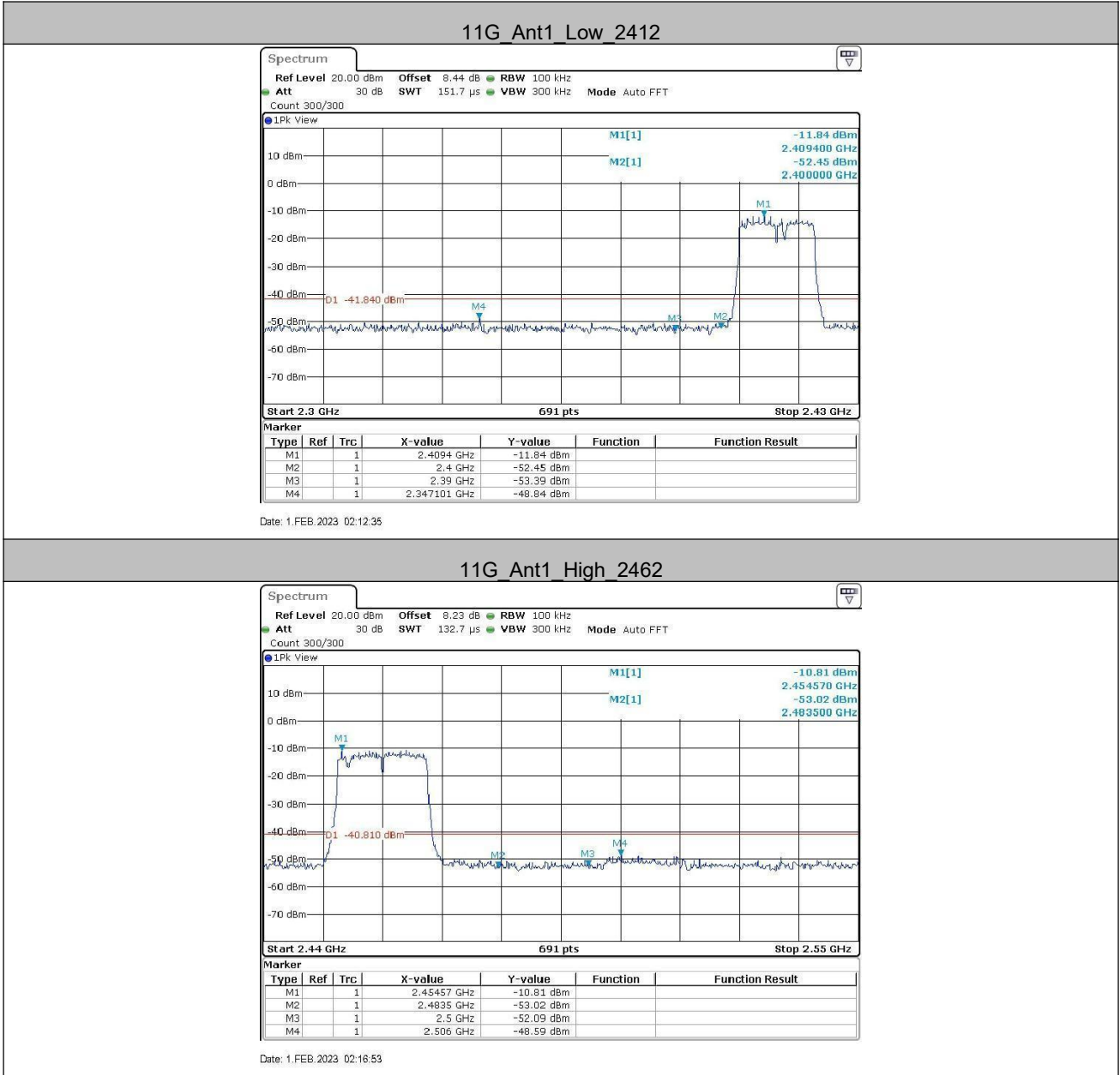

11N20SISO_Ant1_Low_2412

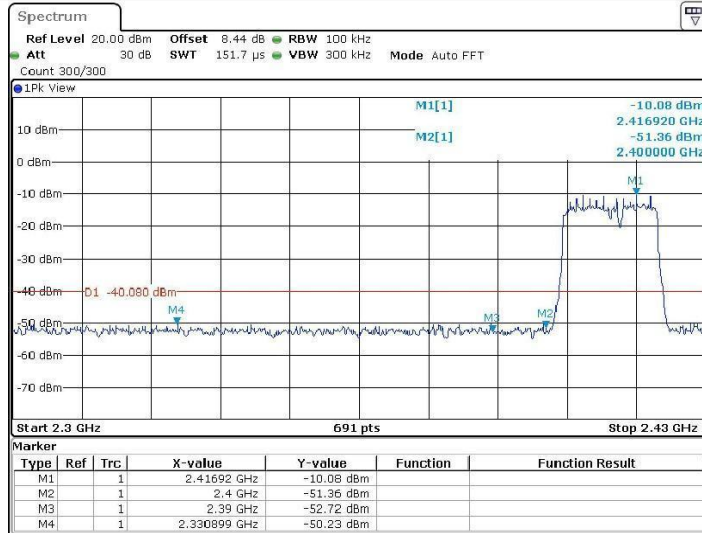

11N20SISO_Ant1_High_2462

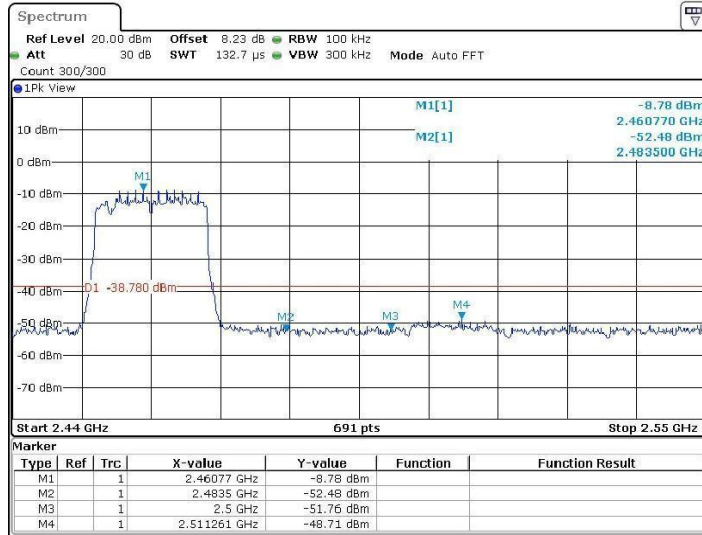

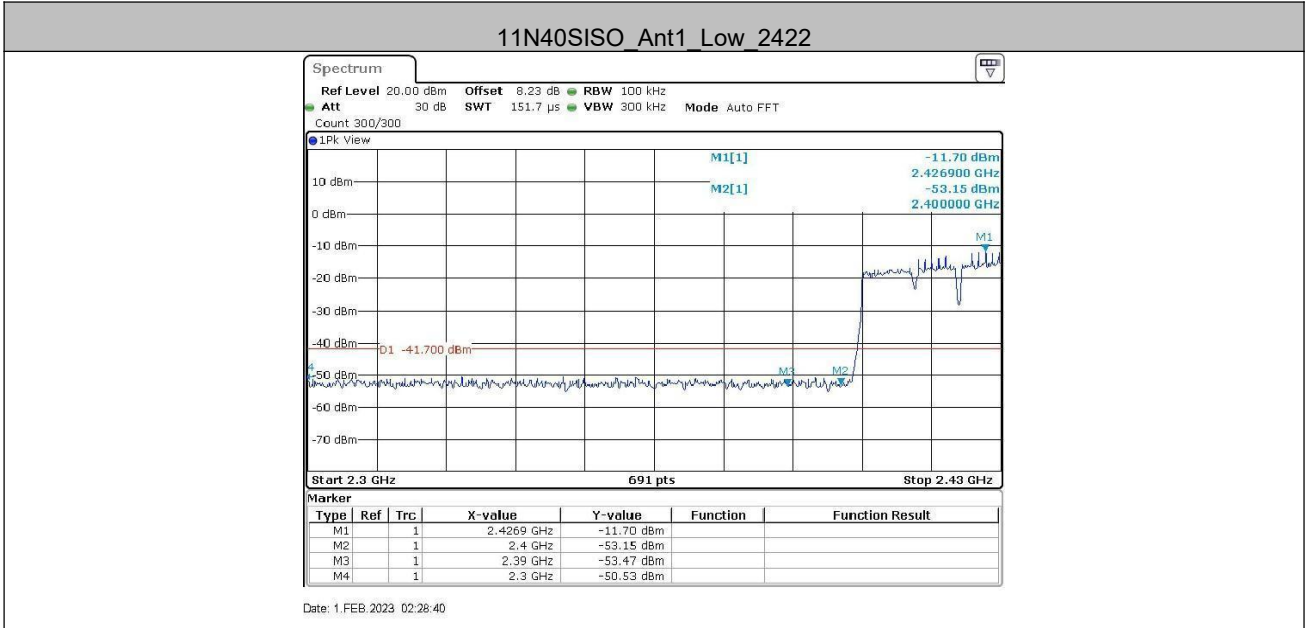

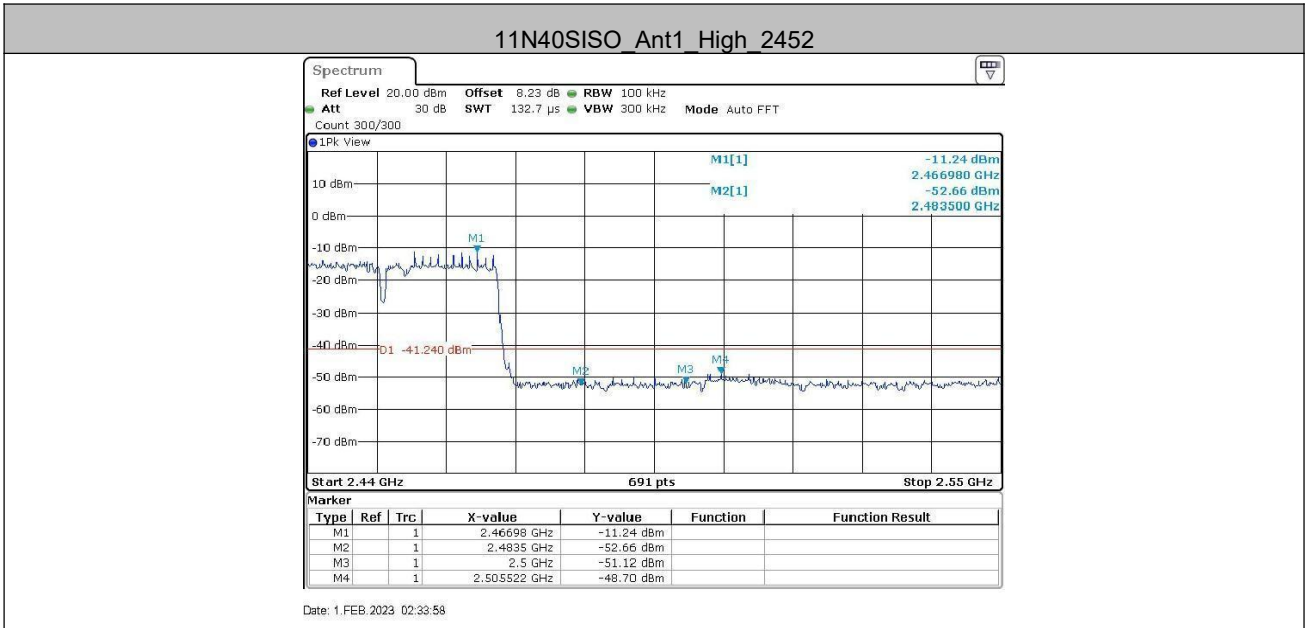

5.7 RF Conducted Spurious Emissions

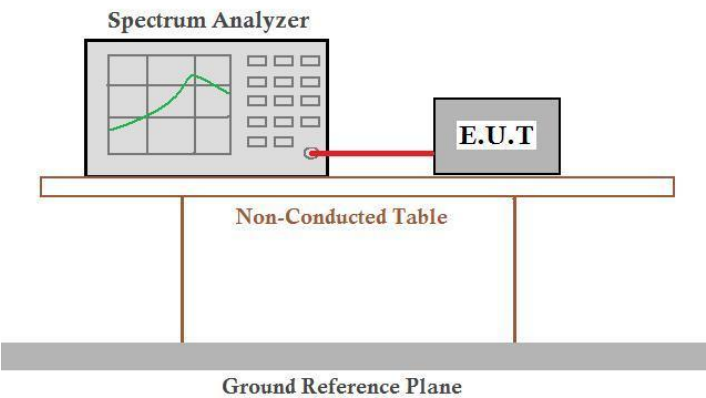
Test Requirement:	47 CFR Part 15C Section 15.247 (d)
Test Method:	ANSI C63.10: 2013
Test Setup:	 <p>The diagram illustrates the test setup for RF conducted spurious emissions. A Spectrum Analyzer is connected to an E.U.T. (Equipment Under Test) via a red cable. Both are placed on a Non-Conducted Table, which is supported by two vertical legs. Below the table is a Ground Reference Plane, represented by a thick grey bar.</p> <p>Offset=cable loss+ attenuation factor</p>
Exploratory Test Mode:	Transmitting with all kind of modulations, data rates
Final Test Mode:	Through Pre-scan, find the 1Mbps of rate is the worst case of 802.11b; 6Mbps of rate is the worst case of 802.11g; 6.5Mbps of rate is the worst case of 802.11n(HT20); 13.5Mbps of rate is the worst case of 802.11n(HT40). Only the worst case is recorded in the report.
Limit:	In any 100 kHz bandwidth outside the frequency band in which the spread spectrum intentional radiator is operating, the radio frequency power that is produced by the intentional radiator shall be at least 20 dB below that in the 100 kHz bandwidth within the band that contains the highest level of the desired power, based on either an RF conducted or a radiated measurement.
Test Results:	Pass

Test Result

TestMode	Antenna	Channel	FreqRange [Mhz]	RefLevel [dBm]	Result [dBm]	Limit [dBm]	Verdict
11B	Ant1	2412	Reference	-8.88	-8.88	---	PASS
			30~1000	-8.88	-55.8	≤-38.88	PASS
			1000~26500	-8.88	-54.67	≤-38.88	PASS
		2437	Reference	-5.88	-5.88	---	PASS
			30~1000	-5.88	-56.73	≤-35.88	PASS
			1000~26500	-5.88	-54.51	≤-35.88	PASS
		2462	Reference	-6.30	-6.30	---	PASS
			30~1000	-6.30	-56.18	≤-36.3	PASS
			1000~26500	-6.30	-55.17	≤-36.3	PASS
11G	Ant1	2412	Reference	-11.48	-11.48	---	PASS
			30~1000	-11.48	-56.34	≤-41.48	PASS
			1000~26500	-11.48	-53.67	≤-41.48	PASS
		2437	Reference	-7.79	-7.79	---	PASS
			30~1000	-7.79	-56.88	≤-37.79	PASS
			1000~26500	-7.79	-54.53	≤-37.79	PASS
		2462	Reference	-8.70	-8.70	---	PASS
			30~1000	-8.70	-55.57	≤-38.7	PASS
			1000~26500	-8.70	-54.44	≤-38.7	PASS
11N20SISO	Ant1	2412	Reference	-9.89	-9.89	---	PASS
			30~1000	-9.89	-55.42	≤-39.89	PASS
			1000~26500	-9.89	-54.52	≤-39.89	PASS
		2437	Reference	-8.71	-8.71	---	PASS
			30~1000	-8.71	-57.56	≤-38.71	PASS
			1000~26500	-8.71	-53.94	≤-38.71	PASS
		2462	Reference	-8.07	-8.07	---	PASS
			30~1000	-8.07	-57.54	≤-38.07	PASS
			1000~26500	-8.07	-54.38	≤-38.07	PASS
11N40SISO	Ant1	2422	Reference	-11.51	-11.51	---	PASS
			30~1000	-11.51	-57.57	≤-41.51	PASS
			1000~26500	-11.51	-55.36	≤-41.51	PASS
		2437	Reference	-12.59	-12.59	---	PASS
			30~1000	-12.59	-56.36	≤-42.59	PASS
			1000~26500	-12.59	-55.13	≤-42.59	PASS
		2452	Reference	-11.06	-11.06	---	PASS

			30~1000	-11.06	-56.29	≤-41.06	PASS
			1000~26500	-11.06	-54.34	≤-41.06	PASS

Test Graphs

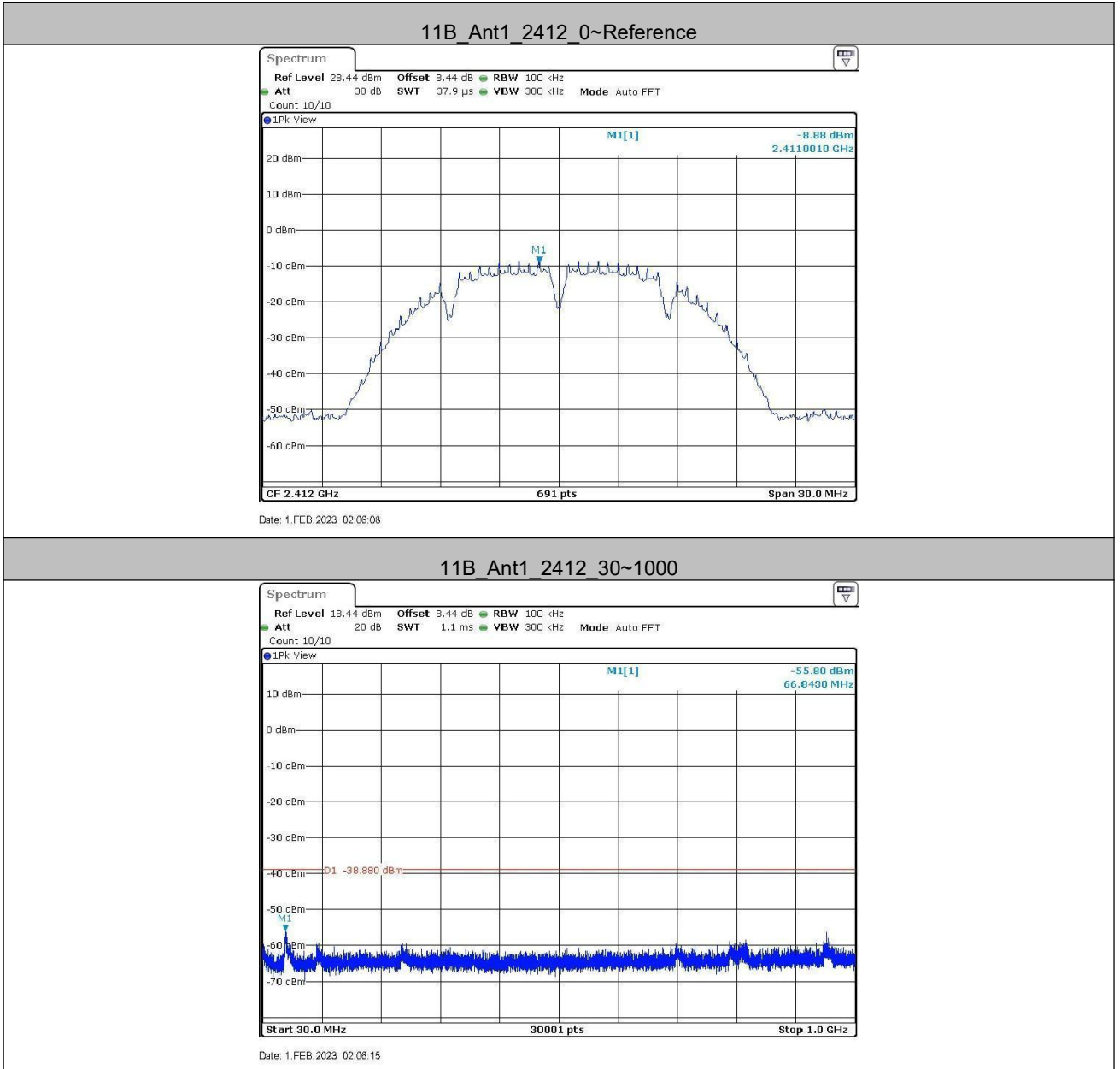

11B_Ant1_2412_1000~26500

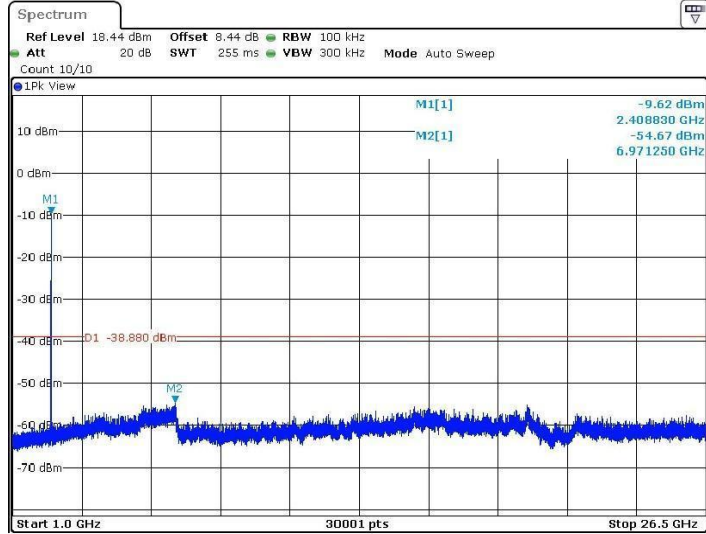

Date: 1.FEB.2023 02:08:37

11B_Ant1_2437_0~Reference

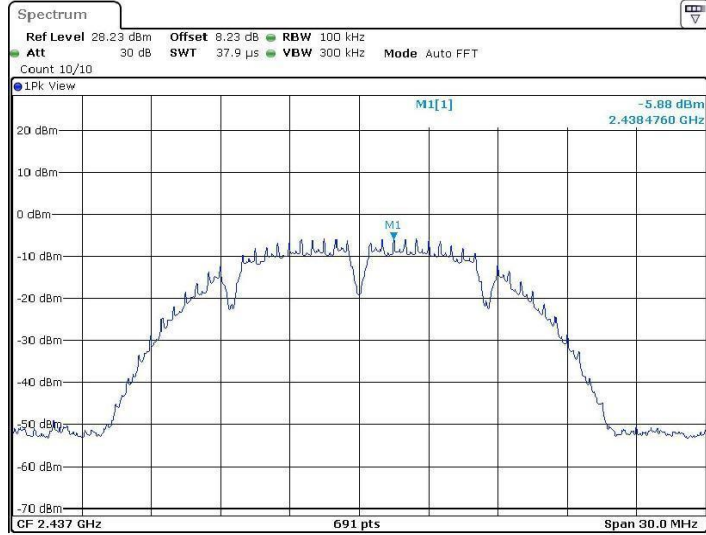

Date: 1.FEB.2023 02:08:03

11B_Ant1_2437_30~1000

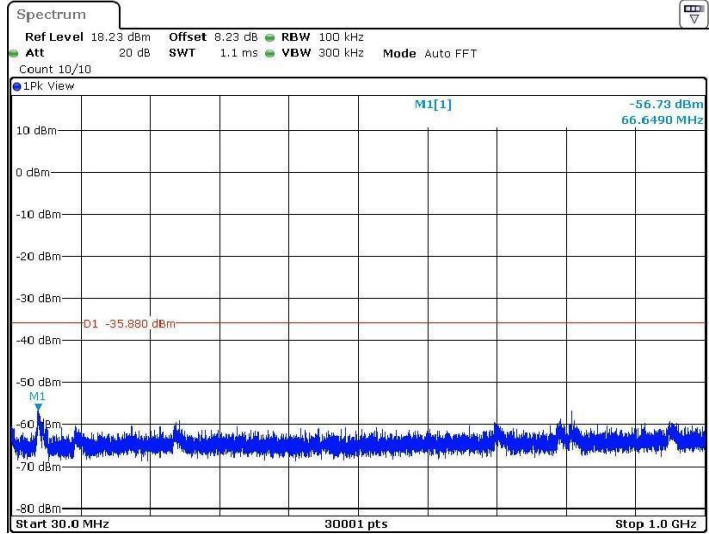

Date: 1.FEB.2023 02:08:09

11B_Ant1_2437_1000~26500

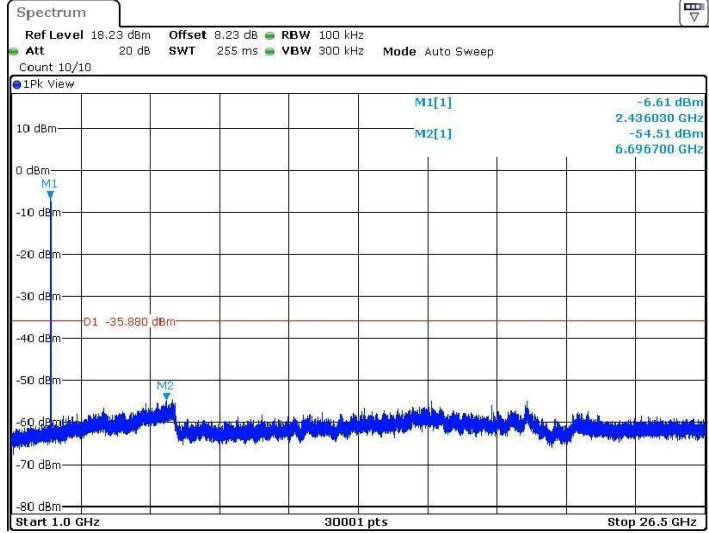

Date: 1.FEB.2023 02:08:32

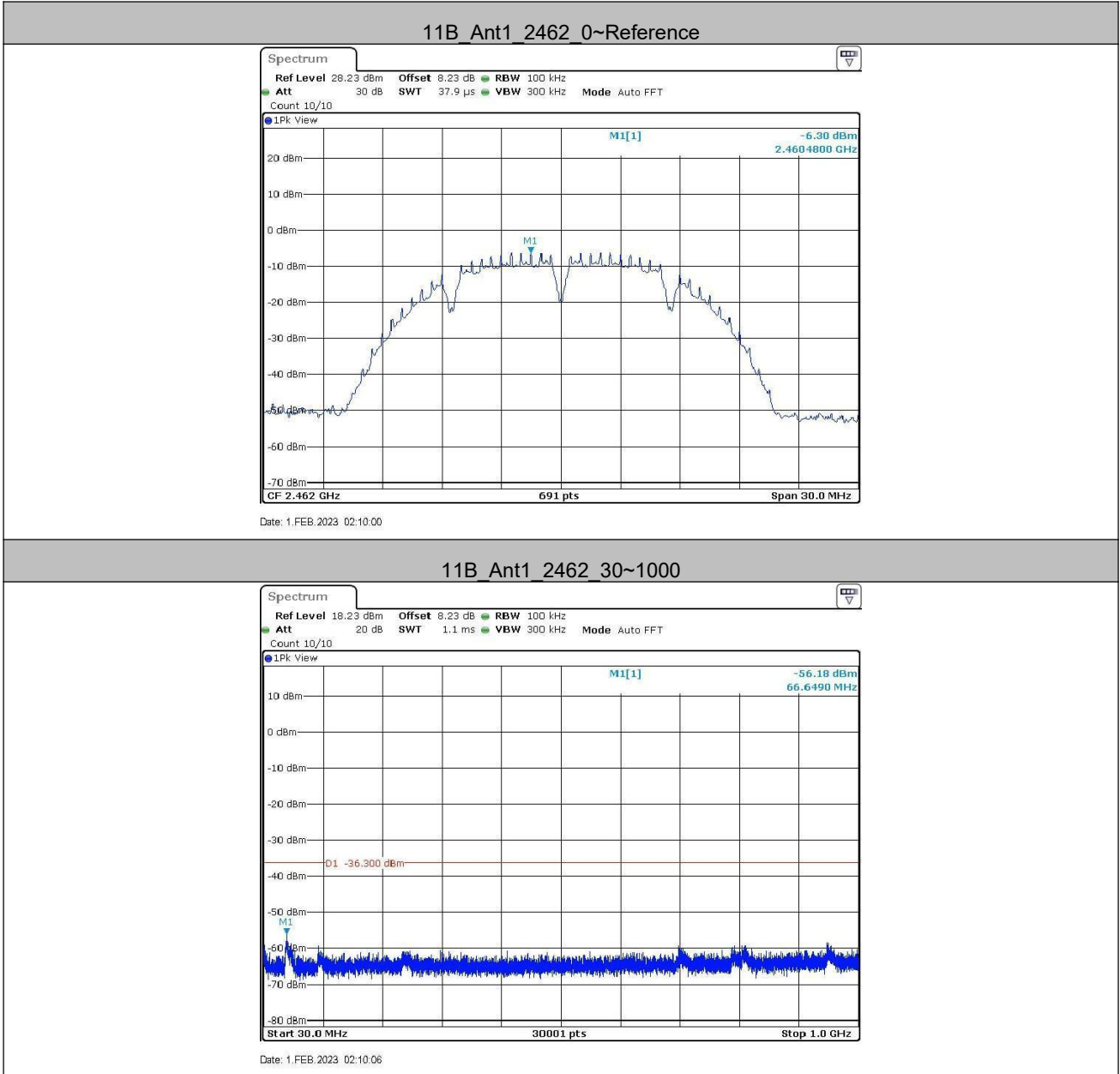

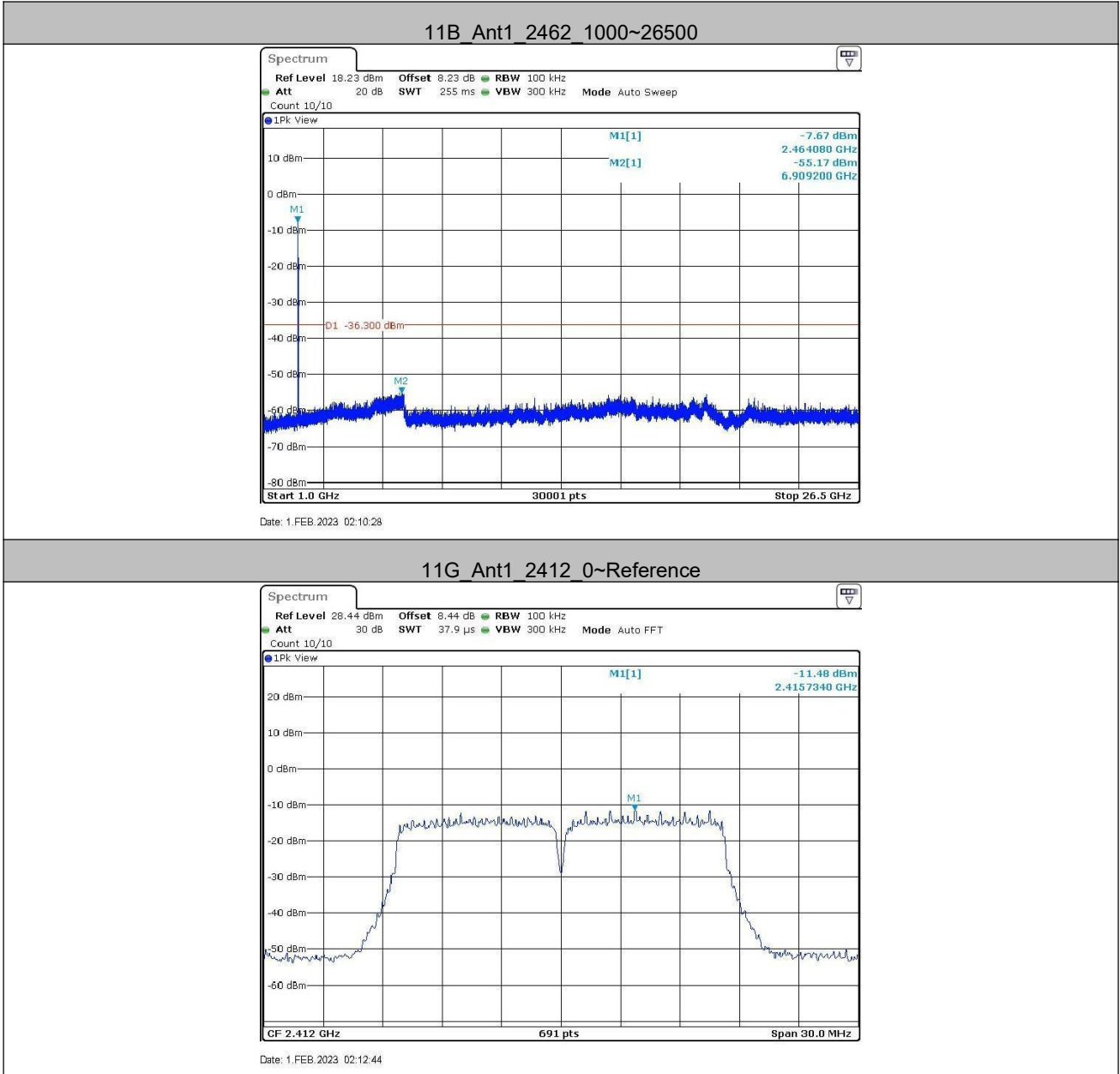

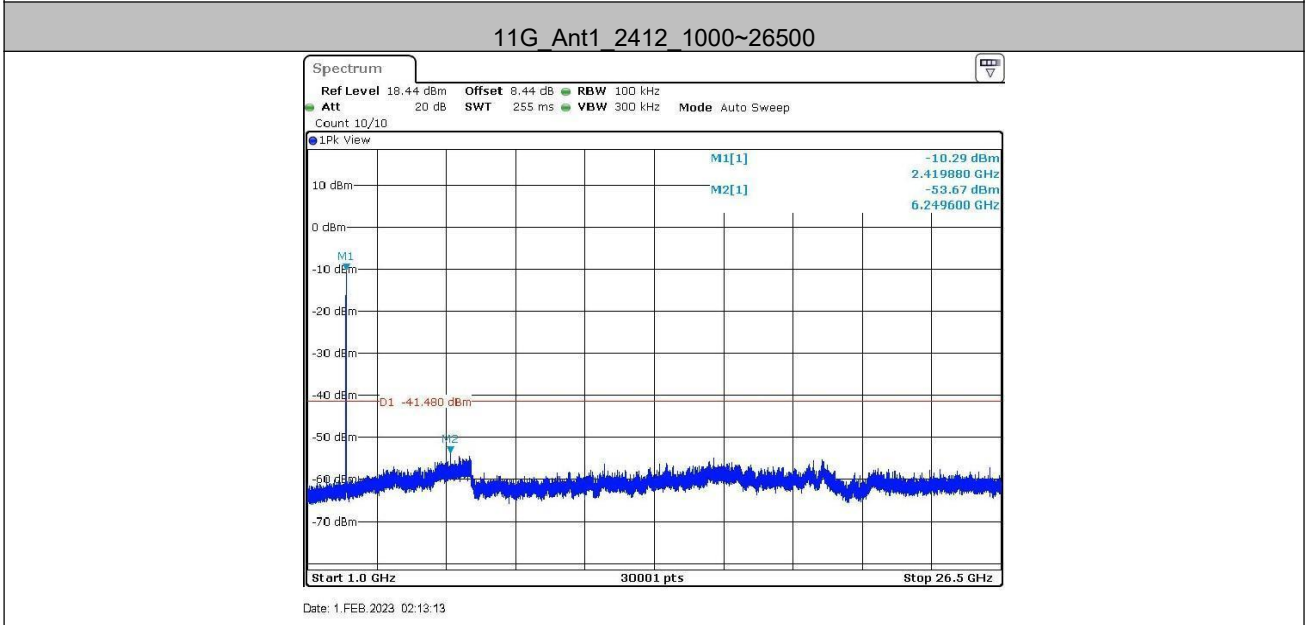
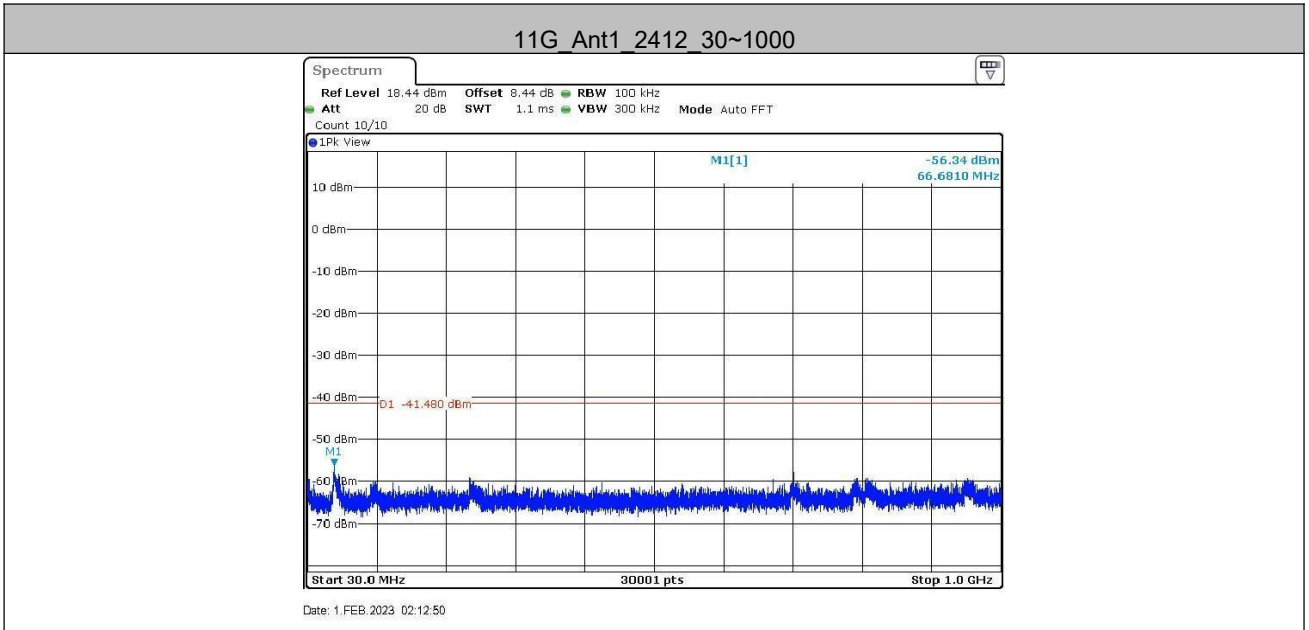

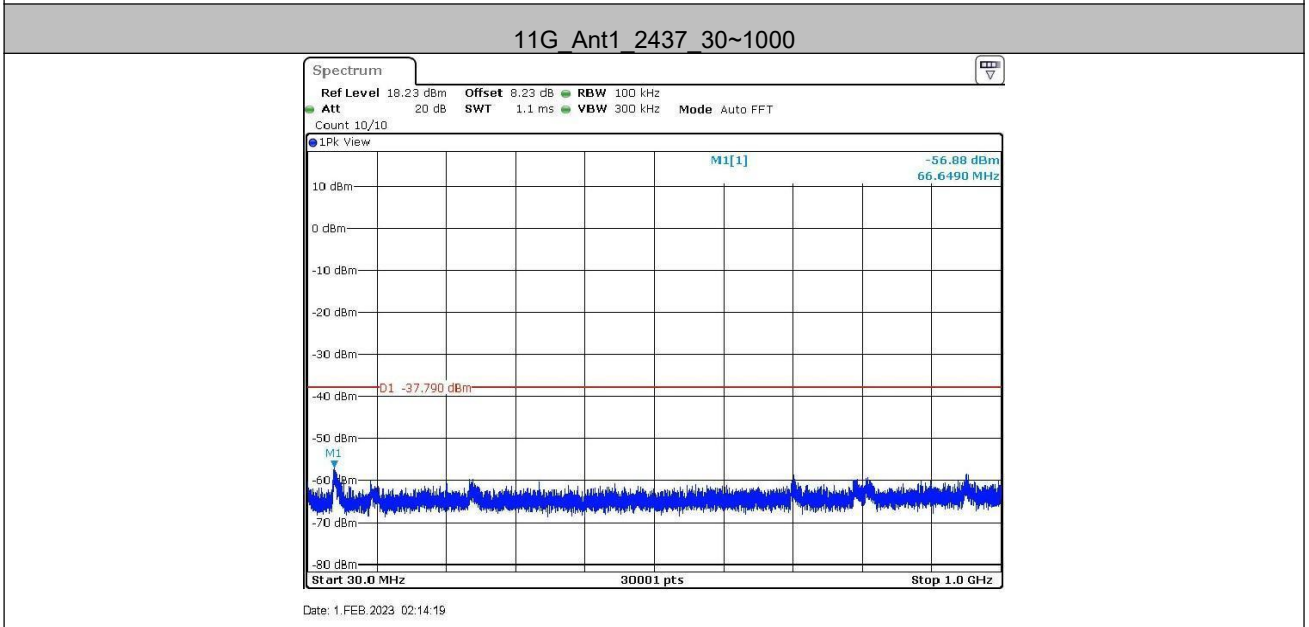
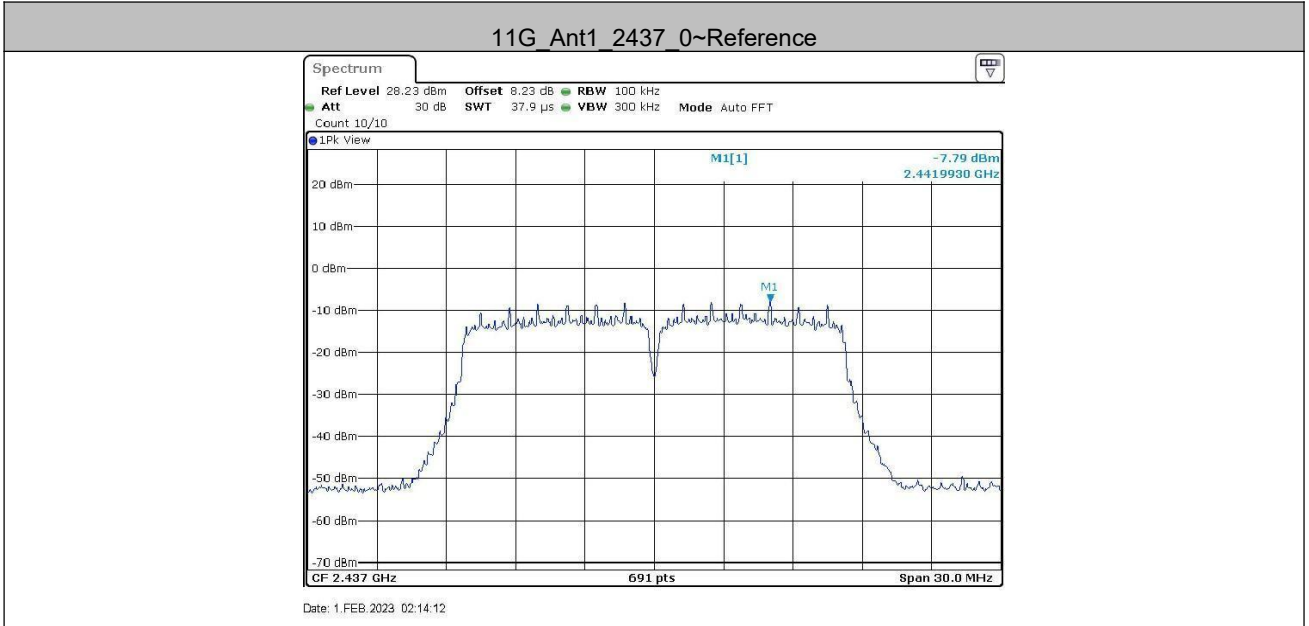

11G Ant1 2437 1000~26500

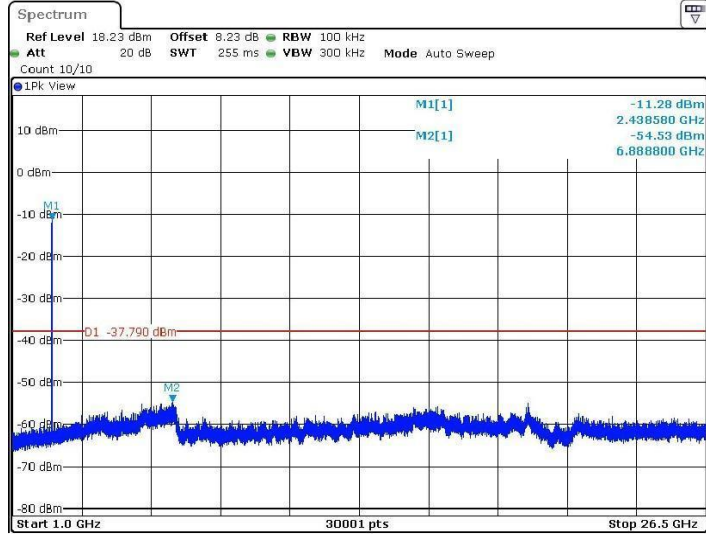

Date: 1.FEB.2023 02:14:41

11G Ant1 2462 0~Reference

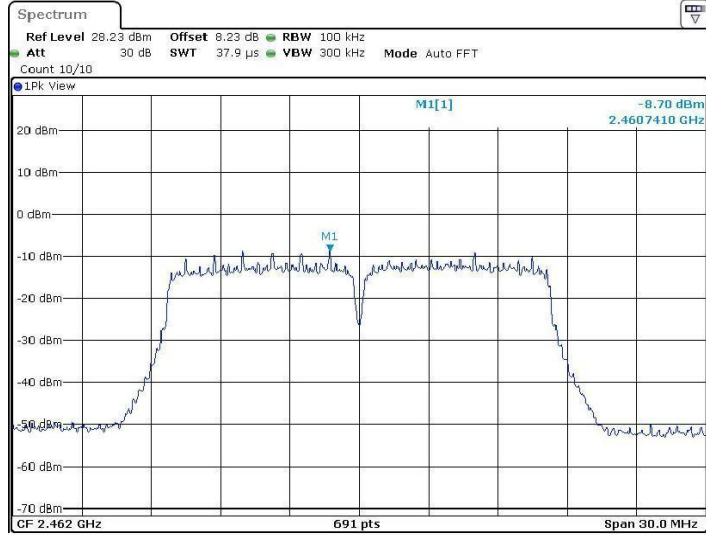

Date: 1.FEB.2023 02:17:02

11G Ant1_2462_30~1000

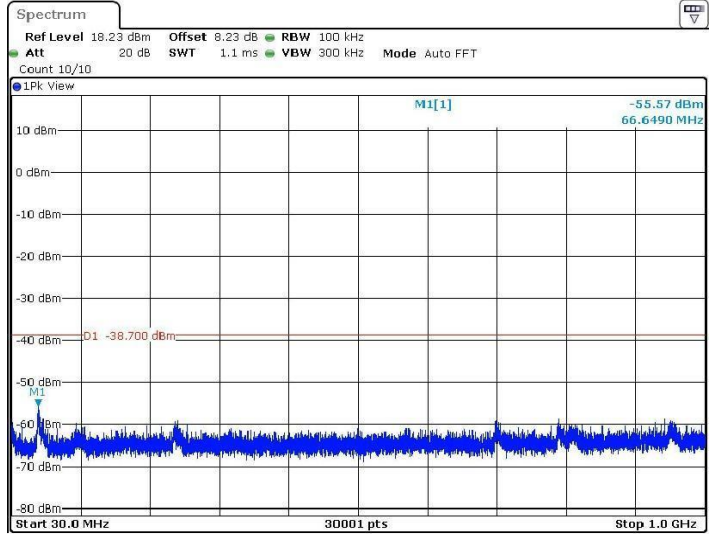

Date: 1.FEB.2023 02:17:08

11G Ant1_2462_1000~26500

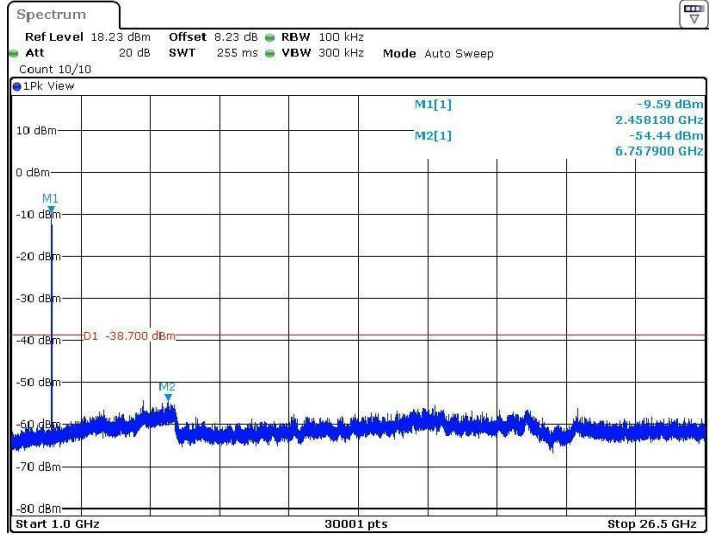

Date: 1.FEB.2023 02:17:30

