

# 产品规格承认书

## SPECIFICATIONS

客户:

CUSTOMER: \_\_\_\_\_

产品名称:

DESCRIPTION: \_\_\_\_\_

客户型号:

CUSTOMER PART NO: \_\_\_\_\_

产品型号:

OUR MODEL NO: \_\_\_\_\_ PBX3216MP01 \_\_\_\_\_

日期:

DATE: \_\_\_\_\_ 2020/12/22 \_\_\_\_\_

# PBX3216MP01 Specification

Operating Temp. : -40°C~+85°C

## 1. FEATURES:

- Light weight, compact
- Wide bandwidth, low cost
- Built-in antenna with high gain

## 2. APPLICATIONS:

- Bluetooth, Wireless LAN, Mobile TV
- Home RF System, etc

## 3. PRODUCT IDENTIFICATION

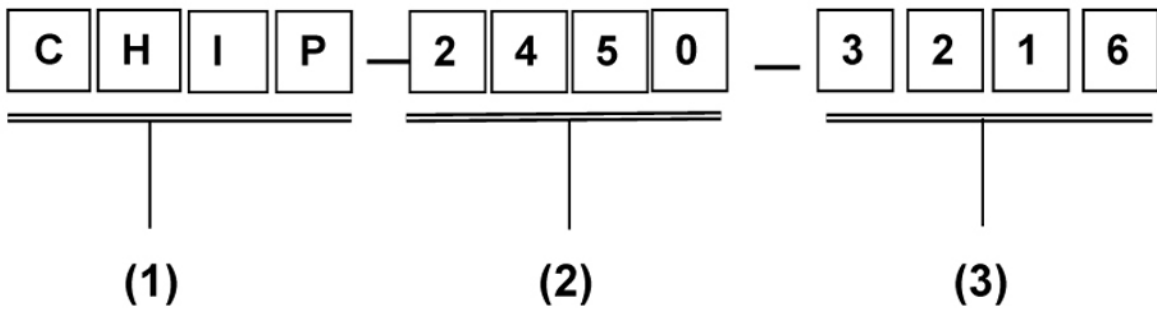

- (1) Product type: Multilayer chip Antenna  
(2) Center Frequency: 2450MHz  
(3) External Dimensions (L×W) (mm): 3.2\*1.6

## 4. SHAPE AND DIMENSIONS:

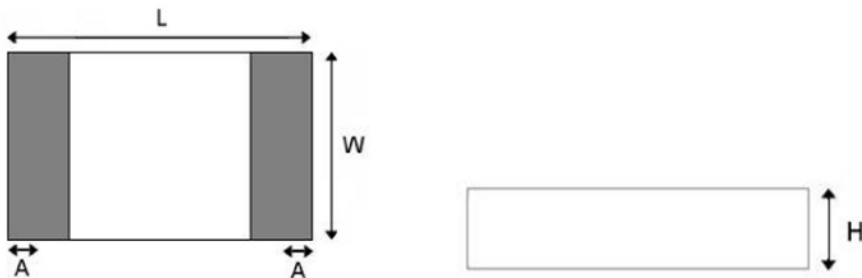

L	W	H	A
3.2±0.2	1.6±0.2	0.52±0.1	0.4±0.1

单位 (units) :mm

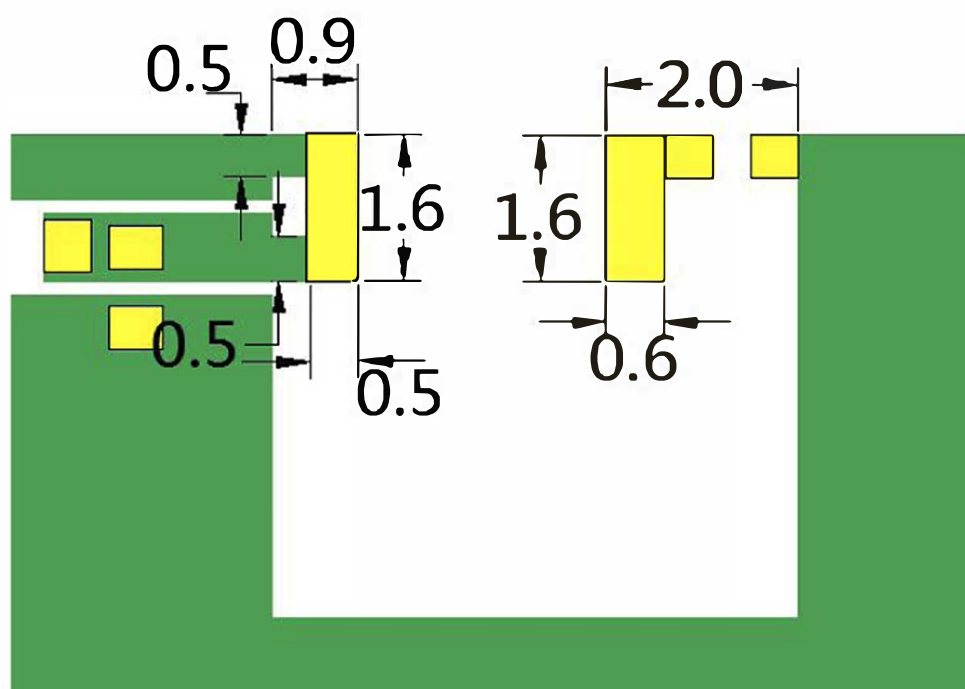
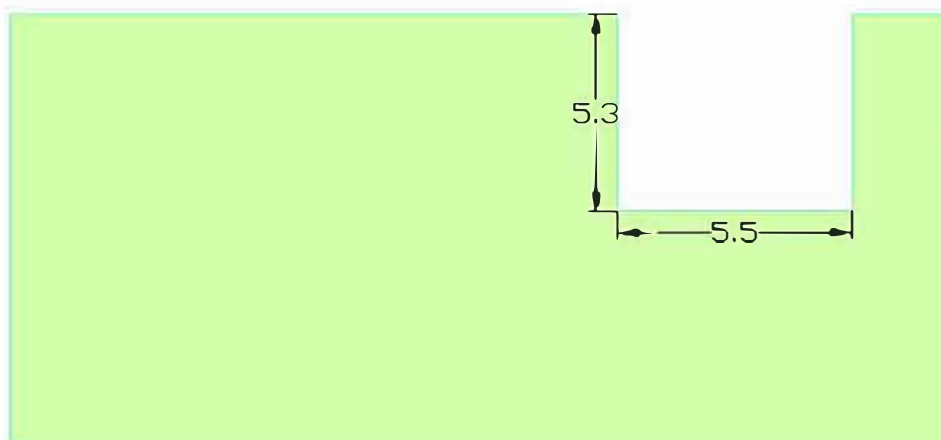
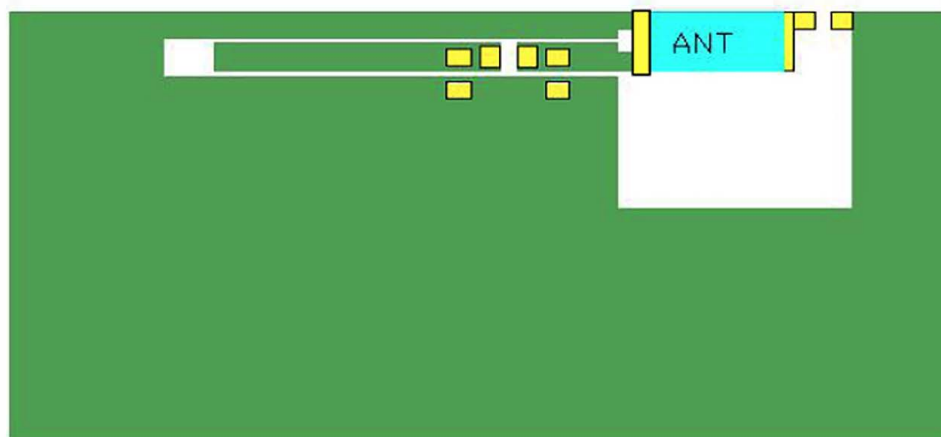

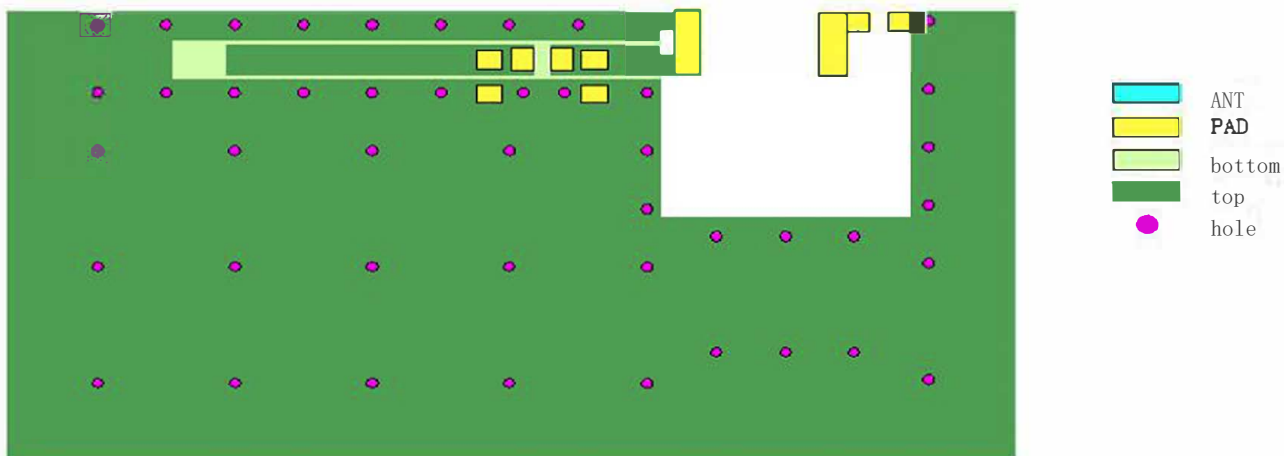

### APPLICATION GUIDE

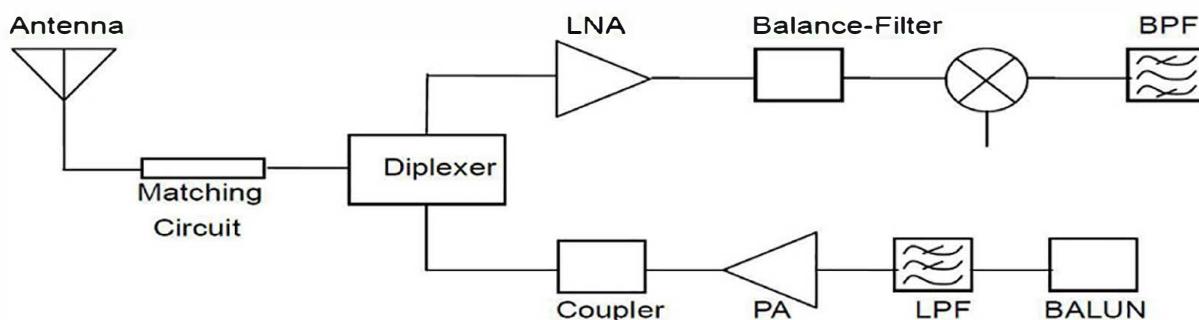

### 5. SPECIFICATIONS:

Item	Specification
Frequency	2400~2483MHz
polarization	Linear
Peak Gain	2.67dBi
efficiency	72.30%
Impedance	50Ω

\* Test condition: Test board size 90\*40 mm  
 Matching circuit: Pi matching circuit will be required

## 6. Electrical Characteristics :

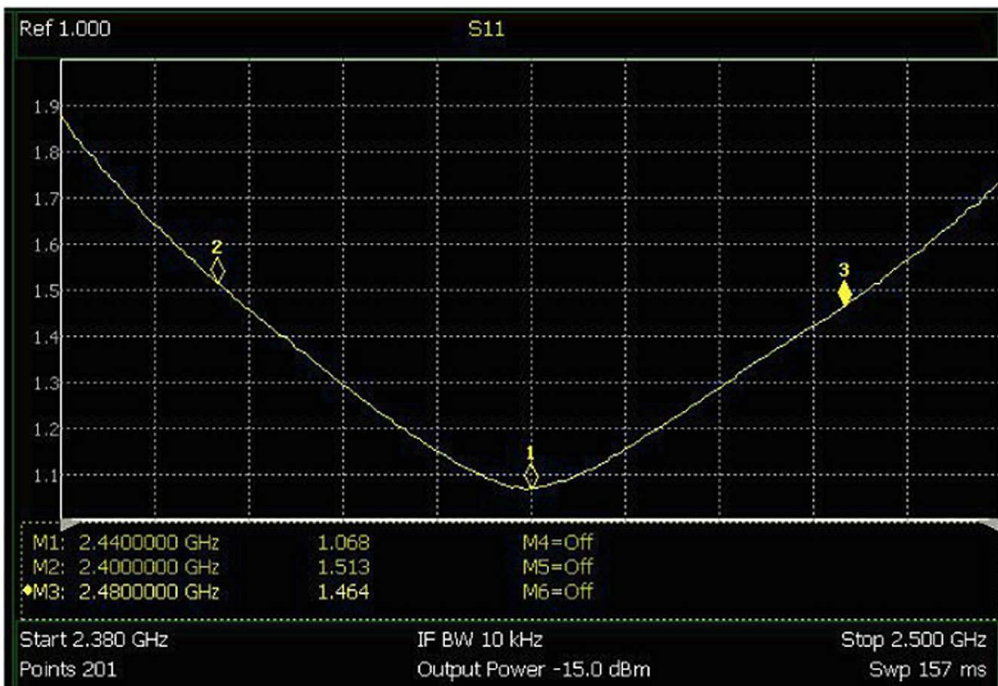
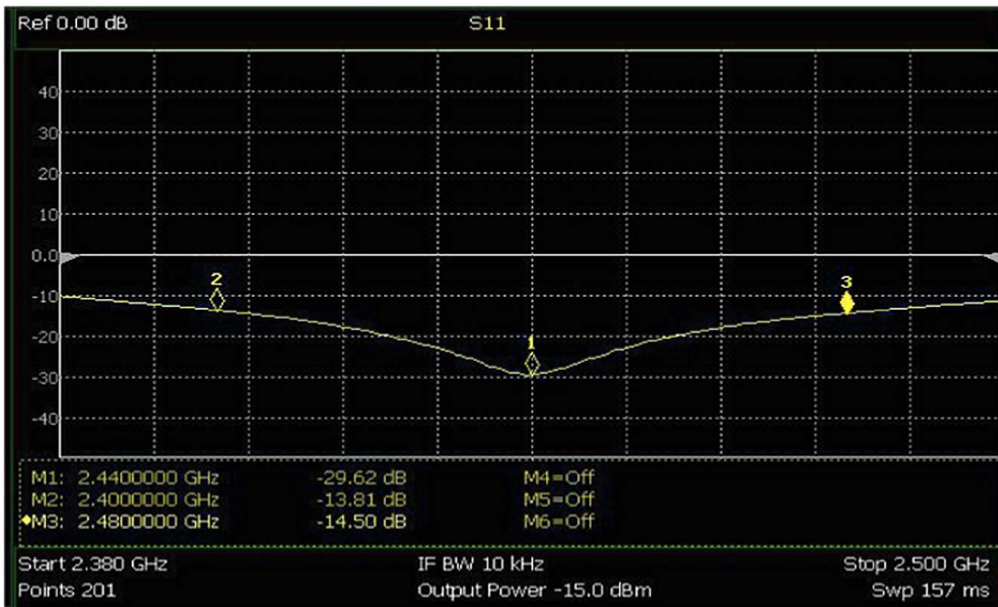

Mark	Frequency	VSWR
1	2400 MHz	1.513
2	2440 MHz	1.068
3	2480 MHz	1.464

## Radiation Pattern

The Gain pattern is measured in FAR-field chamber. DUT is placed on the table of rotator, a standard horn antenna and Vector Network Analyzer is used to collect data.

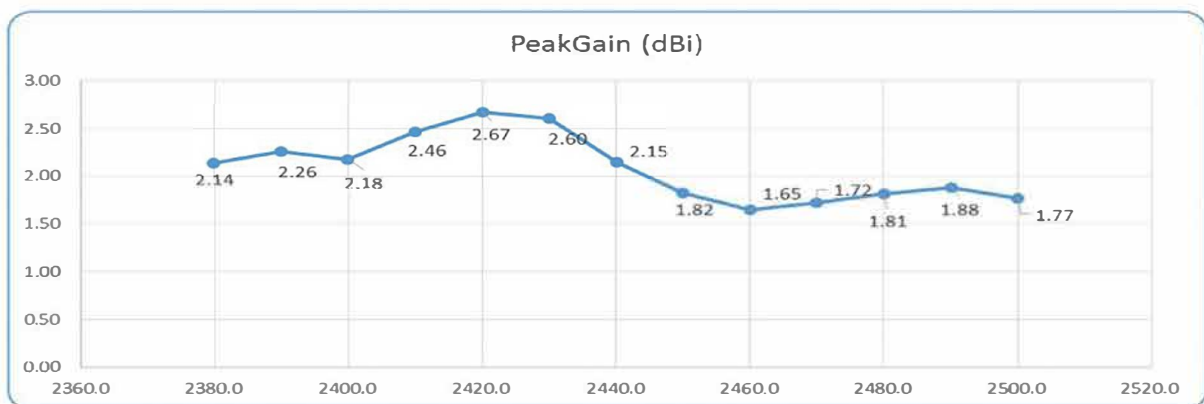
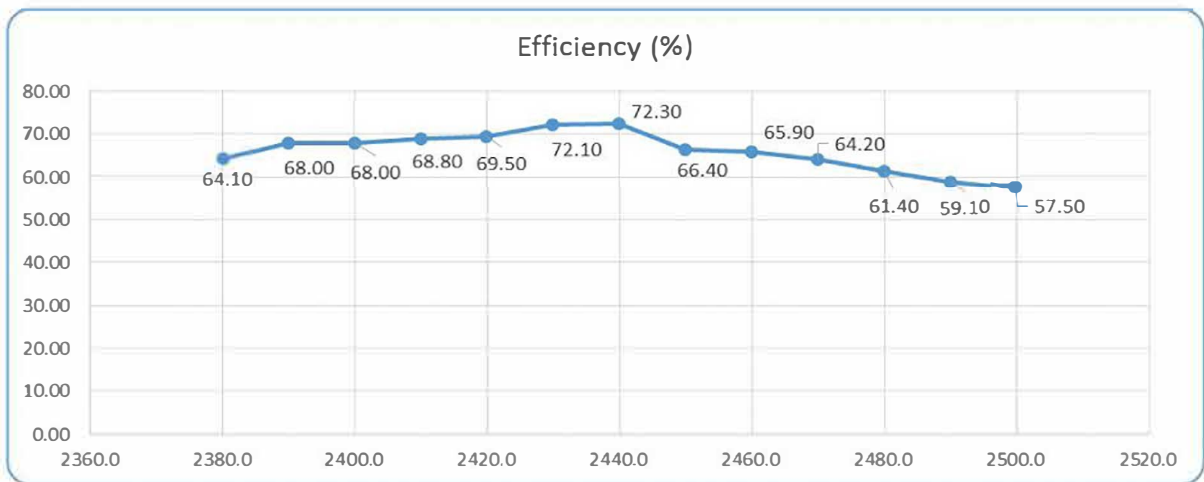
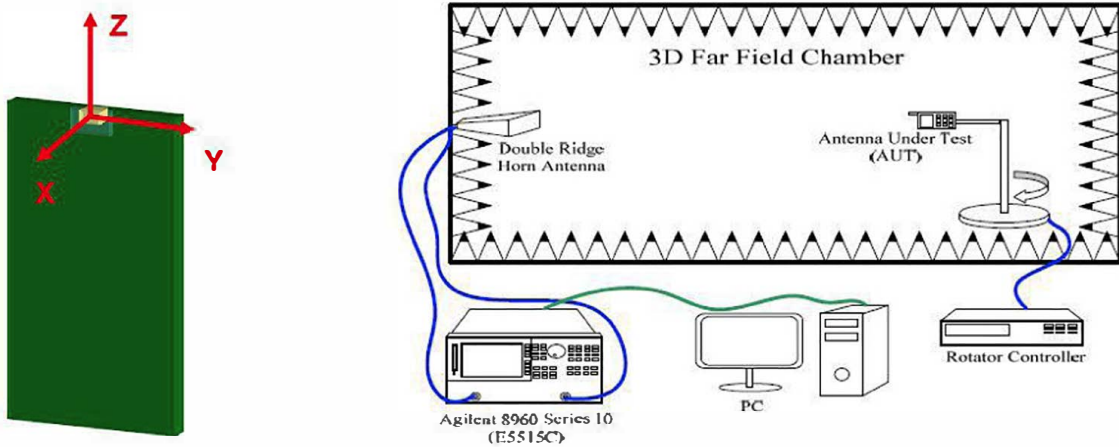

© 3D Gain Pattern (2400 MHz)

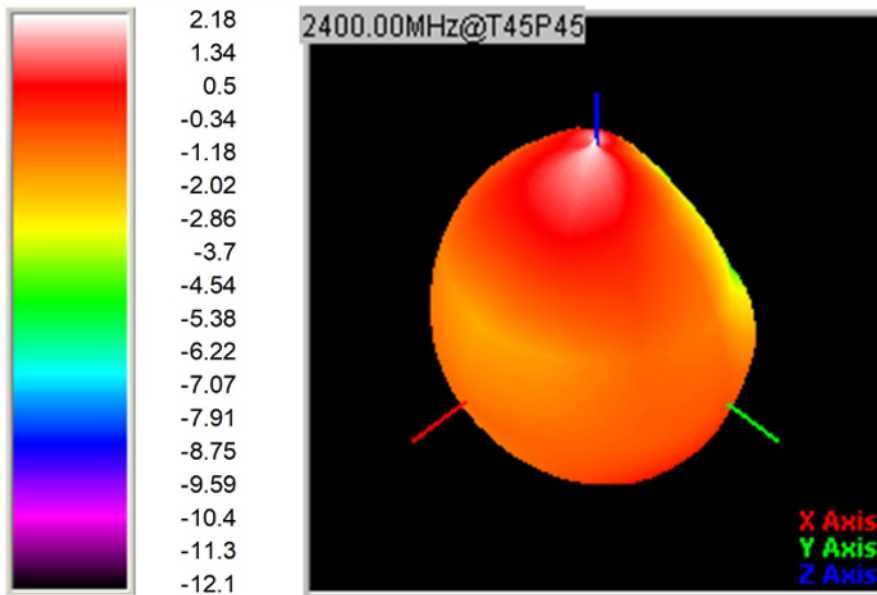

© 3D Gain Pattern (2440 MHz)

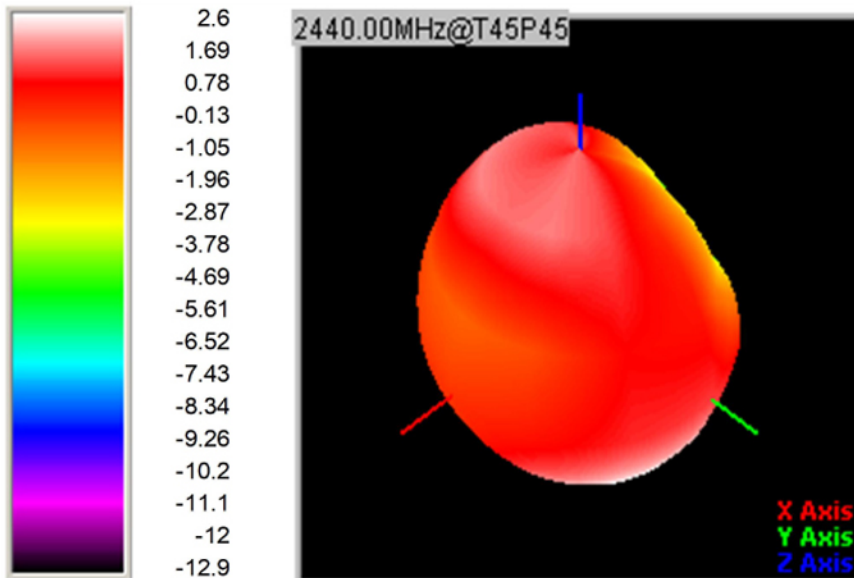

© 3D Gain Pattern (2480 MHz)

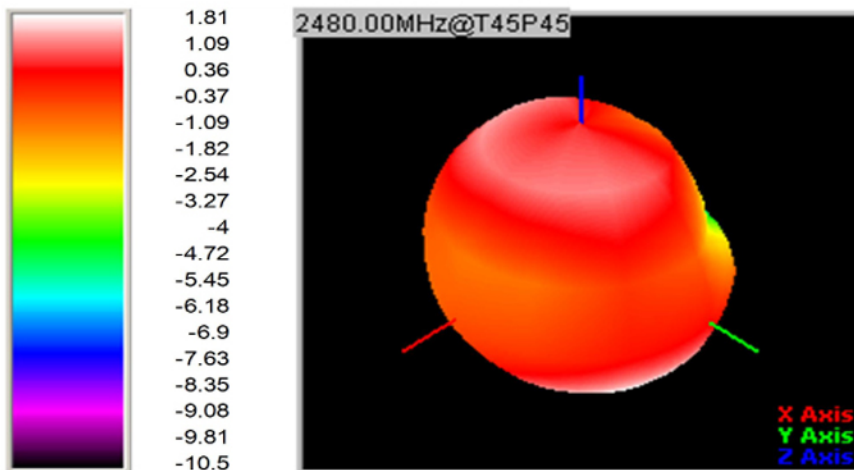

## 7. Environmental Characteristics

### (1) Reliability Test

Item	Condition	Specification
Thermal shock	<ol style="list-style-type: none"> <li>1. <math>30 \pm 3</math> minutes at <math>-40^{\circ} \text{C} \pm 5^{\circ} \text{C}</math>,</li> <li>2. Convert to <math>+105^{\circ} \text{C}</math> (5 minutes)</li> <li>3. <math>30 \pm 3</math> minutes at <math>+105^{\circ} \text{C} \pm 5^{\circ} \text{C}</math>,</li> <li>4. Convert to <math>-40^{\circ} \text{C}</math> (5 minutes)</li> <li>5. Total 100 continuous cycles</li> </ol>	No apparent damage Fulfill the electrical spec. after test.
Humidity resistance	<ol style="list-style-type: none"> <li>1. Humidity: 85% R.H.</li> <li>2. Temperature: <math>85 \pm 5^{\circ} \text{C}</math></li> <li>3. Time: 1000 hours.</li> </ol>	No apparent damage Fulfill the electrical spec. after test.
High temperature resistance	<ol style="list-style-type: none"> <li>1. Temperature: <math>150^{\circ} \text{C} \pm 5^{\circ} \text{C}</math></li> <li>2. Time: 1000 hours.</li> </ol>	No apparent damage Fulfill the electrical spec. after test.
Low temperature resistance	<ol style="list-style-type: none"> <li>1. Temperature: <math>-40^{\circ} \text{C} \pm 5^{\circ} \text{C}</math></li> <li>2. Time: 1000 hours.</li> </ol>	No apparent damage Fulfill the electrical spec. after test.
Soldering heat resistance	<ol style="list-style-type: none"> <li>1. Solder bath temperature : <math>260 \pm 5^{\circ} \text{C}</math></li> <li>2. Bathing time: <math>10 \pm 1</math> seconds</li> </ol>	No apparent damage
Solderability	The dipped surface of the terminal shall be at least 95% covered with solder after dipped in solder bath of $245 \pm 5^{\circ} \text{C}$ for $3 \pm 1$ seconds.	No apparent damage

### (2) Storage Condition

#### (a) At warehouse:

The temperature should be within  $0 \sim 30^{\circ} \text{C}$  and humidity should be less than 60% RH.

The product should be used within 1 year from the time of delivery.

#### (b) On board:

The temperature should be within  $-40 \sim 85^{\circ} \text{C}$  and humidity should be less than 85% RH.

### (3) Operating Temperature Range

Operating temperature range :  $-40^{\circ} \text{C}$  to  $+105^{\circ} \text{C}$ .



## 8. Recommended Reflow Soldering

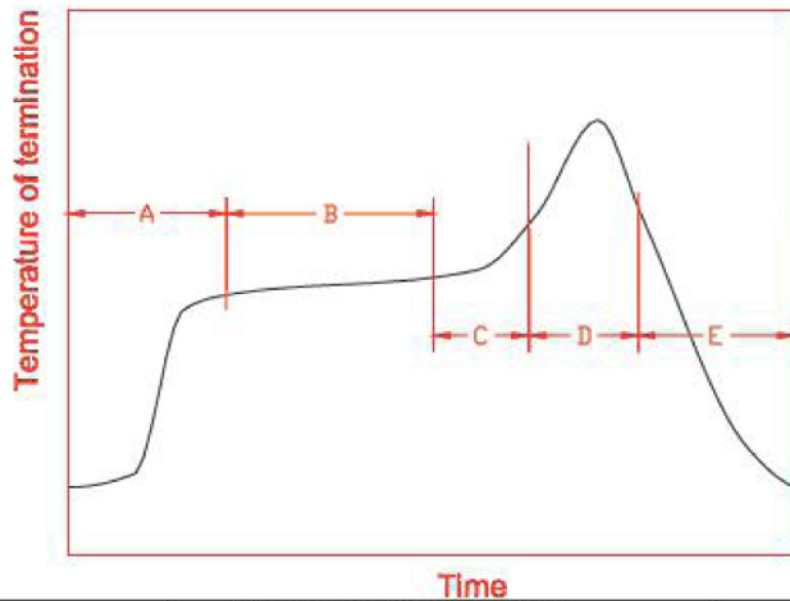

A	1 <sup>st</sup> rising temperature	The normal to Preheating temperature	30s to 60s
B	Preheating	140°C to 160°C	60s to 120s
C	2 <sup>nd</sup> rising temperature	Preheating to 200°C	20s to 40s
D	Main heating	if 220°C	50s~60s
		if 230°C	40s~50s
		if 240°C	30s~40s
		if 250°C	20s~40s
		if 260°C	20s~40s
E	Regular cooling	200°C to 100°C	1°C/s ~ 4°C/s

\*reference: J-STD-020C

### (1) Soldering Gun Procedure

Note the follows, in case of using solder gun for replacement.

- (a) The tip temperature must be less than 350° C for the period within 3 seconds by using soldering gun under 30 W.
- (b) The soldering gun tip shall not touch this product directly.

### (2) Soldering Volume

Note that excess of soldering volume will easily get crack the body of this product.

### 9. Taping Package and Label Marking: (unit: mm)

(1) Quantity/Reel: 5000pcs/Reel

(2) Carrier tape dimensions

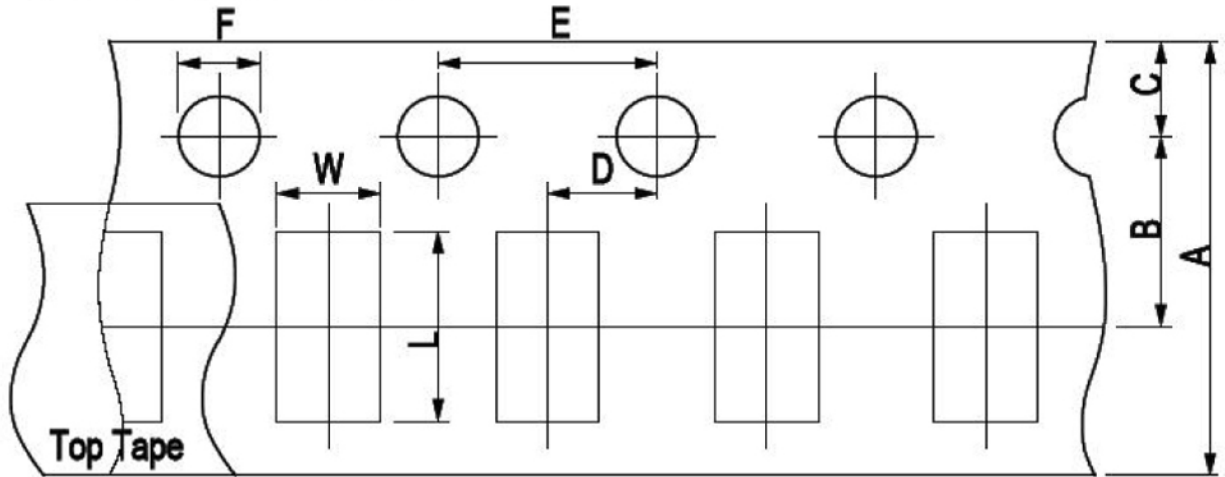

Type	A	B	C	D	E	F	L	W
2450-21	$8.00 \pm 0.3$	$3.50 \pm 0.05$	$1.75 \pm 0.1$	$2.00 \pm 0.05$	$4.00 \pm 0.1$	$1.50 \pm 0.1$	$2.30 \pm 0.1$	$1.55 \pm 0.1$

(3) Taping reel dimensions

