

EWN-8258FAT1HA1

Datasheet V1.4

ZigBee Module

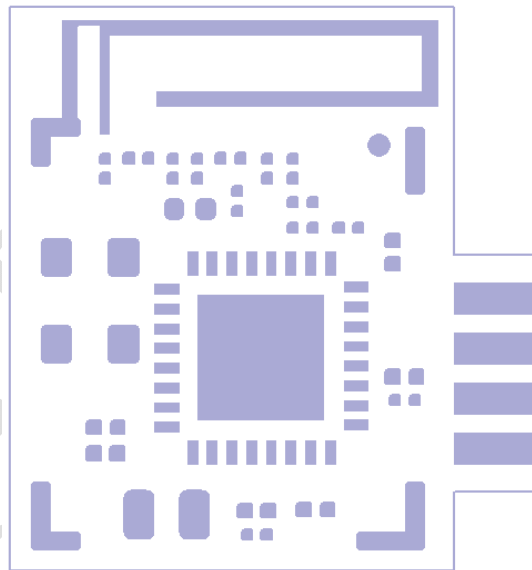

Contents

1	General Specifications	3
2	Features	3
2.1	ZigBee Features	3
2.2	General features	3
3	System Block Diagram	4
4	PHY Specification	4
	Other Specifications	6
5	DC Specifications	6
6	Module configurations	7
7	Pin Definition	9
8	Module Photos	10
9	Key material list	10
10	Package Information	11
11	Reference design	12
11.1	RF	12
11.2	Power supply requirement	13
11.3.1	Interface interference	14
11.3.2	The main chip interferes with DDR	15
12	WARNING	17
12.1	FCC WARNING	17
12.2	IC Caution	18
13	Revision History	19

1 General Specifications

EWN-8258FAT1HA1 is ZigBee SoC solution with internal Flash and audio support, which combines the features and functions needed for all 2.4GHz IoT standards into a single SoC.

2 Features

2.1 ZigBee Features

- ❖ Based on IEEE 802.15.4 Standard, certified Zigbee Pro and ZigBee 3.0 platform, with ZHA/ZLL profile and ZigBee 3.0 device support.
- ❖ Uses multi-hop mesh networking to eliminate single points of failure and expand the reach of networks.
- ❖ Allow low power operation, even support the Green Power feature.
- ❖ Supports networks of thousands of nodes, providing a networking for the smart home or the smart city.
- ❖ Uses a variety of security mechanisms, such as AES-128 encryption, device and network keys and frame counters.
- ❖ Include all application level functionality of ZigBee Smart Energy.
- ❖ Support seamless interoperability with a wide variety of smart devices.
- ❖ Over the air (OTA) firmware upgrade with hardware support.

2.2 General features

- ❖ 14bit 10-channel SAR ADC
- ❖ I/O : I2C、 UART、 PWM
- ❖ Program memory: internal 1MB Flash.
- ❖ Data memory: 64kB on-chip SRAM, including up to 32kB SRAM with retention in deep sleep, and one 32kB SRAM without retention in deep sleep.
- ❖ Embedded hardware AES and AES-CCM.
- ❖ Embedded low power comparator.
- ❖ Swire debug Interface.

3 System Block Diagram

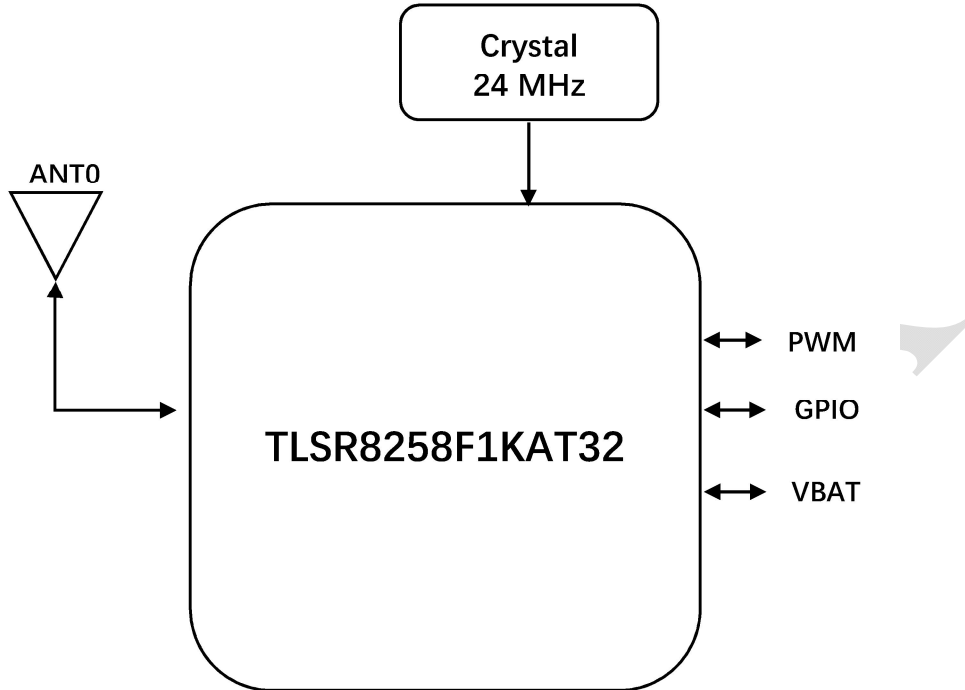

Fig 1 EWN-8258FAT1HA1 System Block Diagram

4 PHY Specification

Table 1 EWN-8258FAT1HA RF Parameters

Protocol	ZigBee
Interface	UART
Frequency	2405-2475MHz
Data rate	802.15.4 250Kbps, ±500Khz deviation

Table 2 RX Performance

Item	Sym.	min	typ	Max	Unit	Condition
IEEE802.15.4(250Kbps) RF_Rx performance (± 500KHz deviation)						
Sensitivity	250Kbps		-99.5		dBm	
Frequency Offset Tolerance		-300		+300	KHz	
Adjacent channel rejection	-1/+1 channel		42/42		dB	Wanted signal at -82dBm
	-2/+2 channel		42/42		dB	Wanted signal at -82dBm
Error vector magnitude	EVM			2%		Max(10dBm)power output

Table 3 TX Performance

Item	Sym.	min	typ	Max	Unit	Condition
IEEE802.15.4(250Kbps) RF_Tx performance						
Output power, maximum setting			10		dBm	
Output power, minimum setting			-45		dBm	
Programmable output power range			55		dB	
Modulation 20dB bandwidth			2.7		MHz	

Other Specifications

Table 4 other Specifications

Operating Temperature	-40°C~+105°C
Storage Temperature	Module: -40°C~+105°C Package: -20°C~+70°C
Operating Humidity	RH 95%(Non-Condensing)
Storage Humidity	RH 95%(Non-Condensing)
Humidity level	Level 3

5 DC Specifications

Table 5 DC Specifications

Item	Sym.	Min.	Typ.	Max.	Unit	Condition
VDD_3.3V	V _{BAT}	1.8	3.3	3.6	V	3.3V Supply Voltage
RX current	I _{RX}	-	5.3	-	mA	whole chip
TX current	I _{TX}	-	4.8	-	mA	whole chip @0dBm with DCDC
TX current	I _{TX}	-	20	-	mA	whole chip @10dBm with DCDC
Deep sleep with	I _{deep1}		1		uA	8kB SRAM retention
			1.2		uA	16kB SRAM retention
			1.4		uA	32kB SRAM retention
	I _{deep2}		0.4		uA	without SRAM retention

6 Module configurations

Module Size (Unit: mm): $13.50(\pm 0.2) * 14.30(\pm 0.3) * 2.4(\pm 0.2)$

Suggested slot size : $0.9\pm 0.05 * 6.5\pm 0.1$ mm (The PCB slot reserved copper sheet)

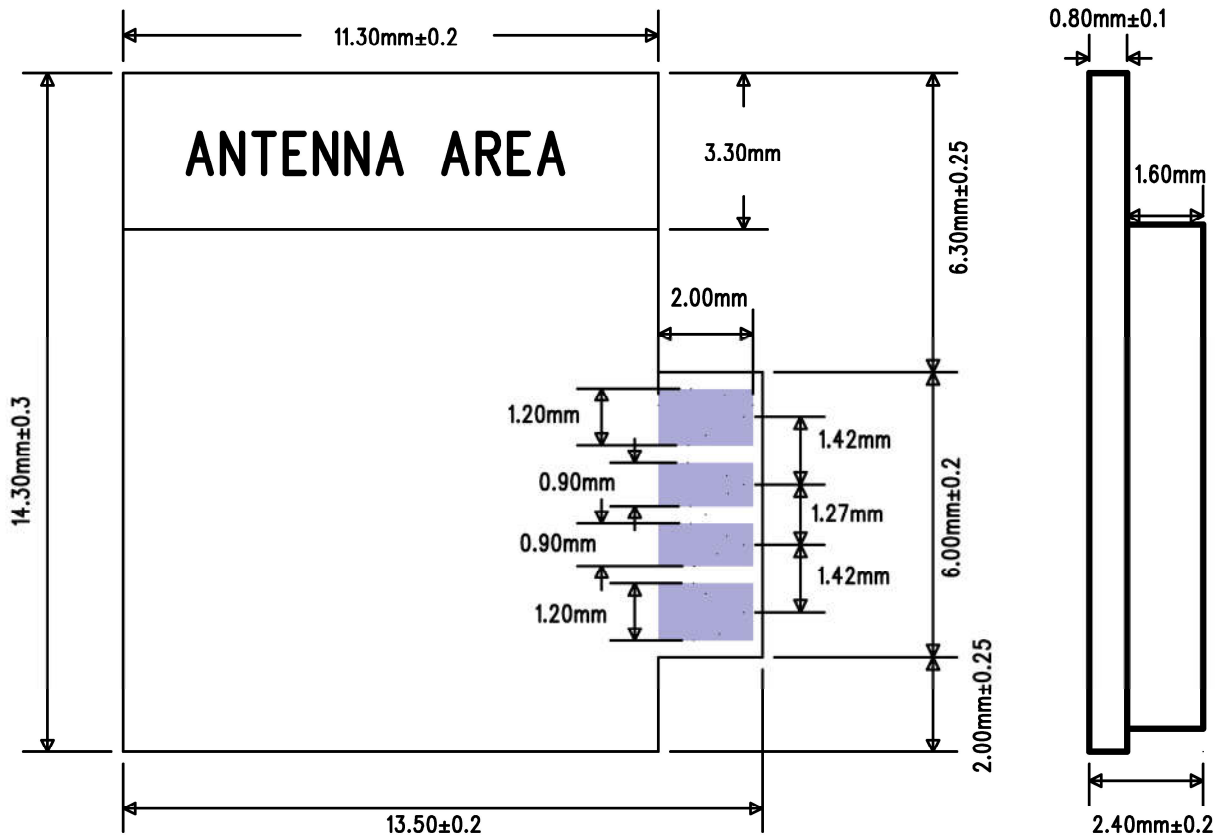

Fig 2 EWN-8258FAT1HA1 Top View Module Size

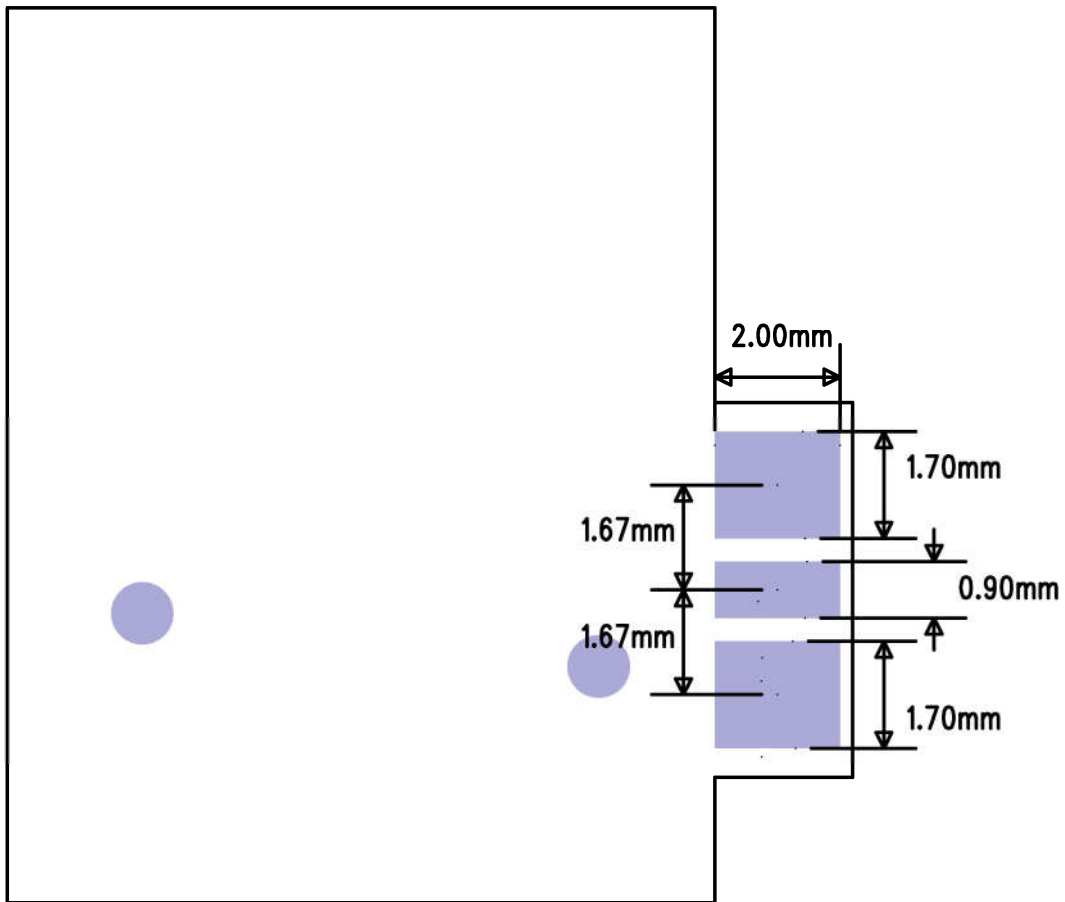

Fig 3 EWN-8258FAT1HA1 Bottom View Module Size

7 Pin Definition

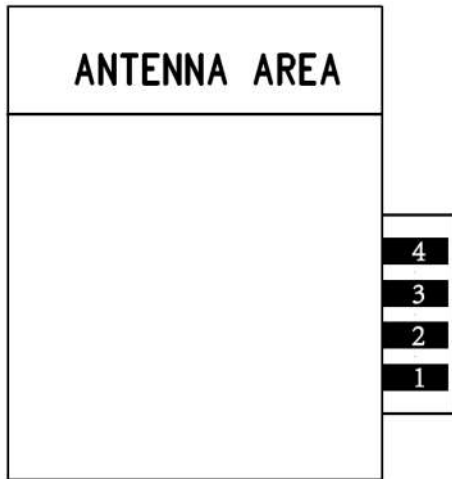

Fig 4 Top view

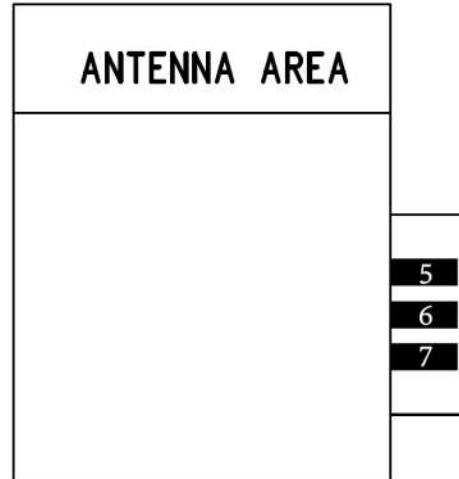

Fig 5 Bottom view

Table 6 the hardware Pin definition of the module

Table 6 EWN-8258FAT1HA Pin definition

PIN	Definition	IC Pin	Description
1	VBAT	/	Supply power 1.8V-3.3V ;
2	PWM4	PB4	PWM4 output for LED drive ; SAR ADC Input ; SDM positive output 0; Low power comparator input; General I/O port ;
3	PWM5	PB5	PWM5 output for LED drive ; SAR ADC Input; SDM negative output 0; Low power comparator input; General I/O port ;
4	PWM2	PC4	PWM2 output for LED drive ; SAR ADC Input; UART_CTS; General I/O port ;
5	PWM1	PC3	PWM1 output for LED drive ; UART_RX; I2C serial clock; PGA right channel negative input; General I/O port ;
6	PWM0	PC1	PWM0 output for LED drive ; I2C serial clock; PGA left channel negative input; General I/O port ;
7	GND	/	Module power reference;

Notes:

1. Download Interface use SWS test point on bottom view.
2. Only SWS interface can be used for debugging firmware.

8 Module Photos

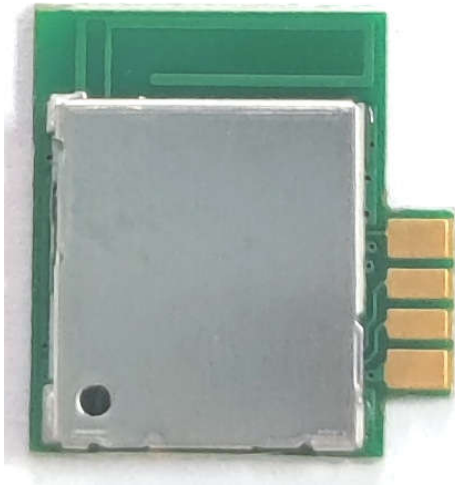

Fig 6 Top View



Fig 7 Bottom View

9 Key material list

Table 7 EWN-8258FAT1HA1 Key material list

Type	Model	Footprint	QTY.
Crystal	24MHz 12pF 20ppm	3225	1PCS
Inductance	10uH	0805	1PCS
IC	TLSR8258F1KAT32	QFN32	1PCS

10 Package Information

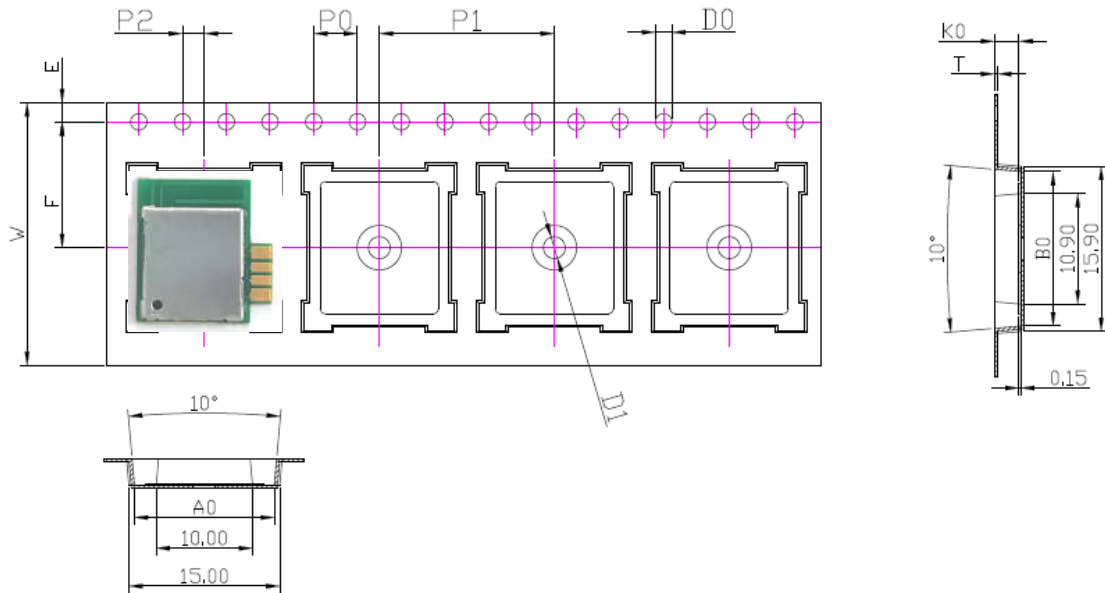

FIG 8 Carrier size

Reel dimension : D=38cm 1500PCS Modules Per Reel

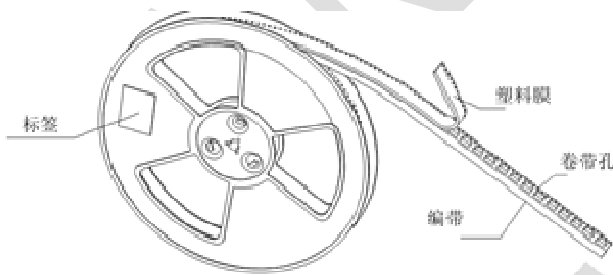

FIG 9 Reel



FIG 10 Reel figure

11 Reference design

11.1 RF

a) Under the antenna and in the two directions indicated by the arrow, avoid covering the ground, routing and placing metal components. It is better to directly hollow out the PCB in this area.

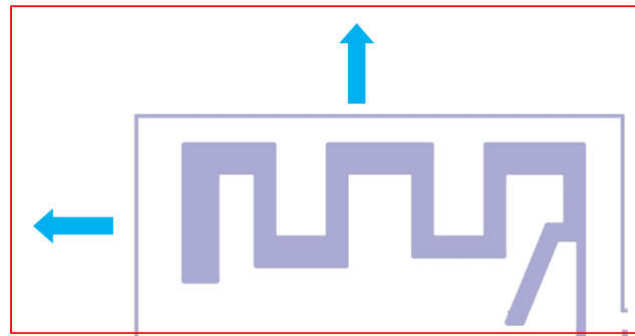

Fig 11 Antenna

b) It is recommended not to use any components within 30mm of the module antenna area, and the module baseboard should also avoid wiring and covering the ground as much as possible.

c) It is strongly recommended that the user place the antenna of the Bluetooth module close to the edge of the backplane as far as possible when laying out the PCB, as shown in the figure below, so as to ensure the good performance of the antenna.

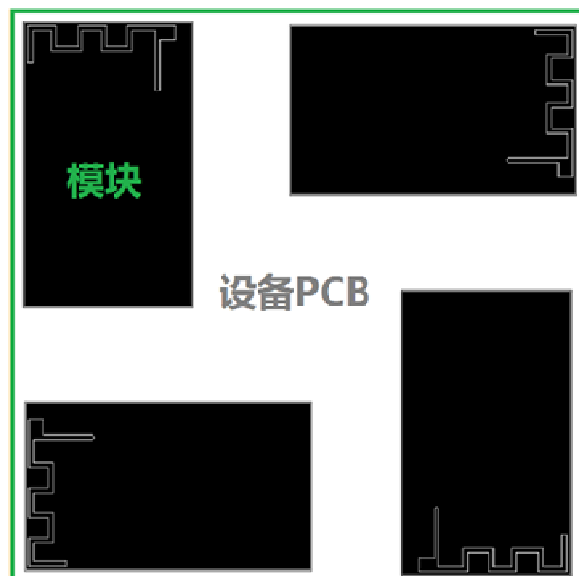
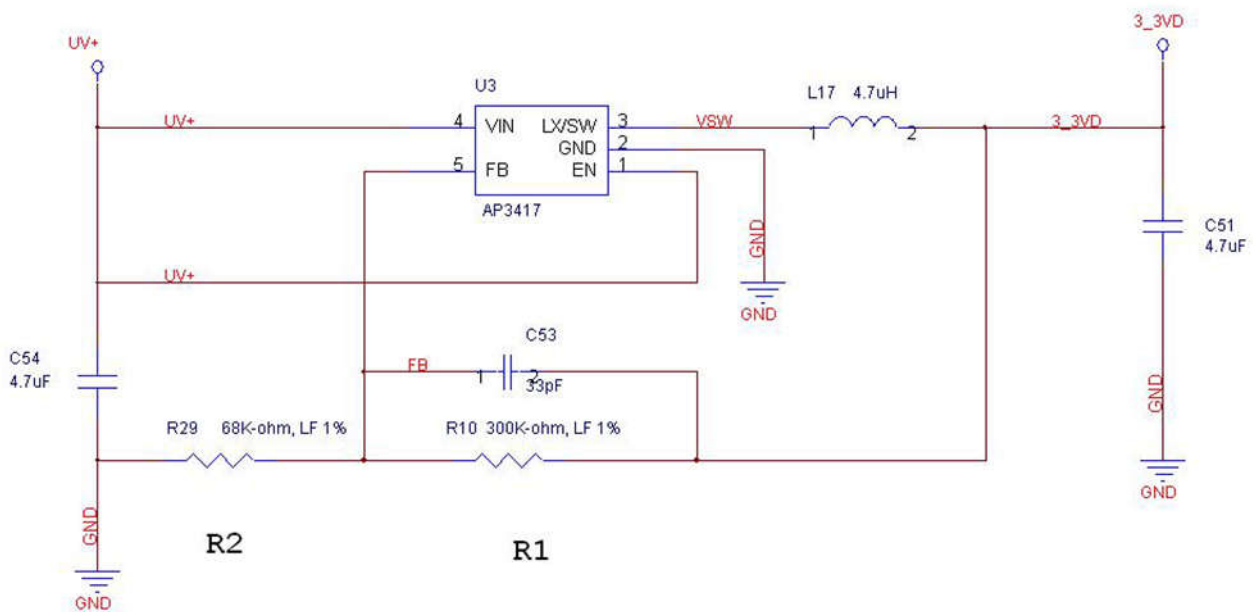

Fig 12 Recommended PCB layout

11.2 Power supply requirement

The module power supply voltage is DC+3.3V. The power supply design needs to consider the output current and power interference. The power supply current design needs to reserve 50mA. To avoid the +3.3V power supply from interfering with other circuits on the motherboard, it is recommended to supply to the module using the regulator circuit alone. the recommended DC-DC circuit structure shown in the figure below. A 4.7uF~10uF capacitor is connected in parallel at 3_3VD output to filter out the interference. A bead is connected in series at 3_3VD output. The bead and capacitor must be placed as close to the module as possible. If you need to share +3.3V with other circuits, consider whether the current of the shared power supply is sufficient.



$$V_o = 0.6 * (1 + R1/R2) = 0.6 * (1+300K/68K) = 3.3V$$

Step-Down Regulator, Vfb=0.6V, 1A, 1.8MHz, ADJ, LF

Fig 13 Power supply Circuit schematic

11.3 Motherboard interference avoidance

Motherboard interference comes from: high-speed data interface (HDMI), the Operating frequency of main chip, DDR, DC-DC power supply. The method of avoiding interference according to the characteristics of various signals is also different. The main methods of interference avoidance include:

1. keeping away from the source of interference;
2. Adding shields to avoid interference leakage;
3. Reasonable layout to eliminate interference.

11.3.1 Interface interference

When HDMI uses the 74.2MHz frequency, its 33x frequency is in the 2.4G band of BT, which will seriously interfere with the BT signal. If the HDMI frequency is 148.5MHz, although the 16x frequency is not in the BT band, the isolation of the frequency is not good, and the BT signal will be interfered to some extent. If the distance between the HDMI interface and the BT module on the PCB is less than 5cm, the HDMI output display will interfere with the BT signal, resulting in problems such as BT connection failure and throughput drop. Therefore, keep the location of the BT module away from the HDMI port on the hardware layout to avoid interference.

At the same time, if the BT antenna is built-in the motherboard, its placement must also be carefully considered to be far from the interface interference. If the antenna is placed in an incorrect position, even if the module is shielded, the interference signal is coupled through the antenna, which will eventually result in a lower BT throughput. (Note: In addition to interference, the placement of the internal antenna should also evaluate the effect of the metal interface, motherboard, and housing material on the antenna impedance.)

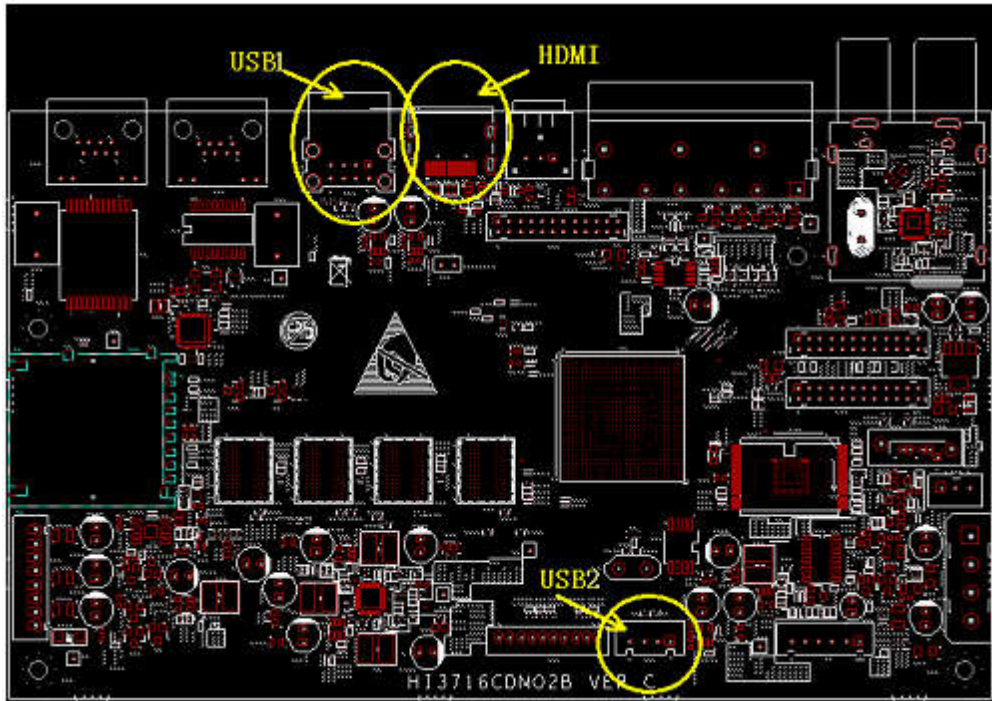

Fig 14 HDIM and USB interference

11.3.2 The main chip interferes with DDR

Because the main chips operate at about 800MHz or DDR2 operate at 667MHz, 3x frequency of 800MHz and 4x frequency of 667MHz are near 2.4GHz band. It must to place BT modules and antennas far away from the main chip and DDR. It is strongly recommended that the main chip be isolated from the DDR by a shield. As shown in the figure below.

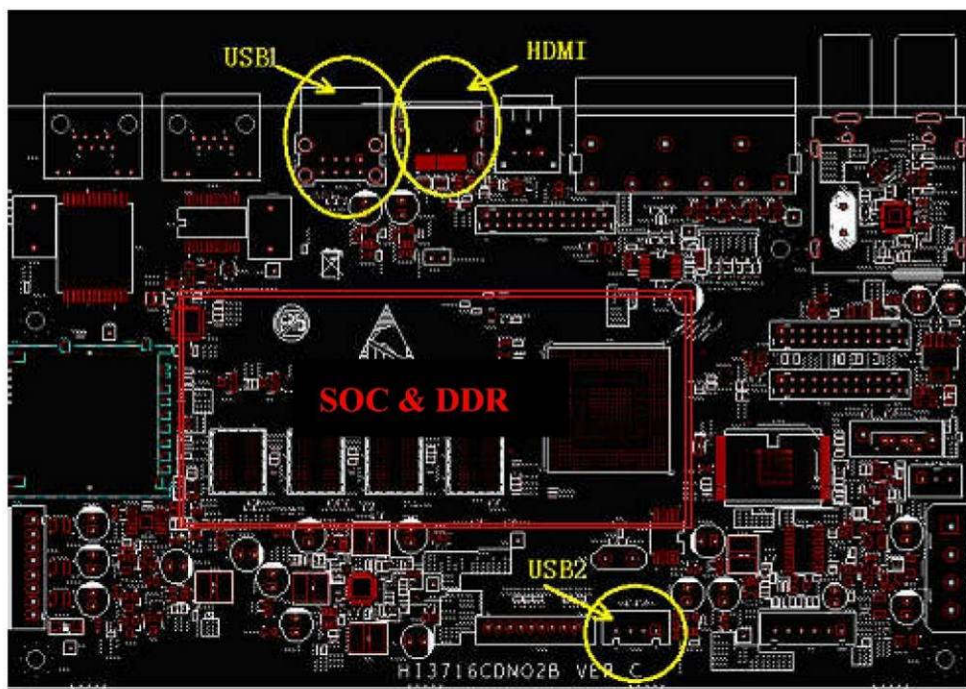

Fig 15 Main chip and DDR interference

11.4 Recommended secondary reflux temperature curve

The number of reflux shall not exceed 2 times, and the tin feeding height of the half hole of the module shall be no less than 1/4.

The lead-free reflux curve requirements of BT module products are shown in figure 13 :

Stage	Note	Pb-free assembly
Average ramp-up rate	T_L to T_p	3 °C/ second max.
Preheat	Temperature min (T_{smin})	150°C
	Temperature max (T_{smax})	200°C
	Time (t_{smin} to t_{smax})	60 – 120 seconds
Time maintained above	Temperature(T_L)	217°C
	Time (t_L)	60 – 150 seconds
Peak package body temperature (T_p)		T_p must not exceed the specified classification temp($T_c=245^\circ\text{C}$).
Time(t_p) within 5°C of the specified classification temperature (T_c)		30 seconds
Ramp-down rate (T_p to T_L)		6 °C / seconds max.
Time 25°C to peak temperature		8 minutes max.

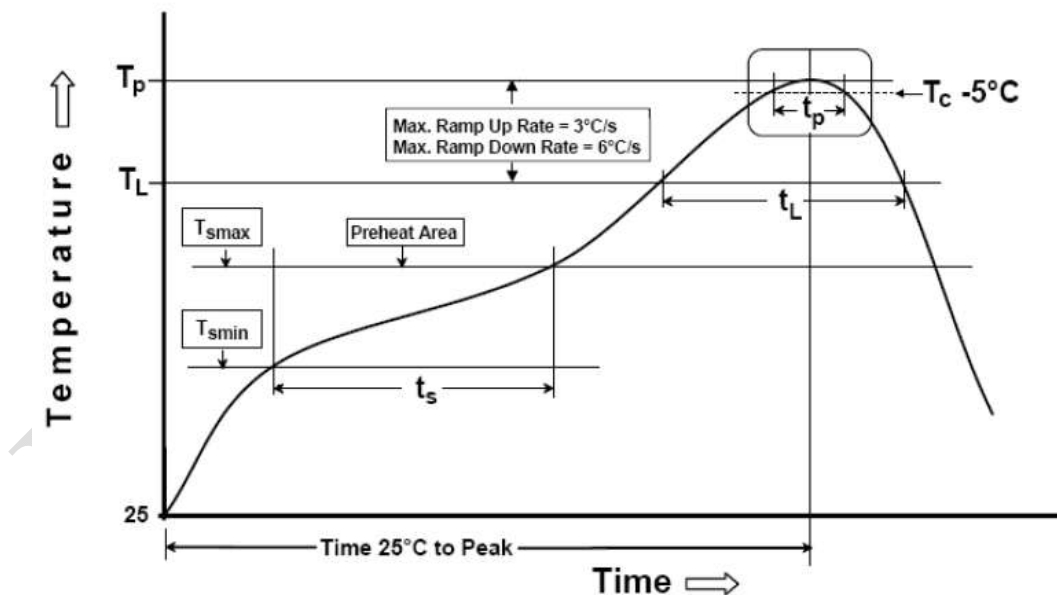

Fig 16 Furnace temperature curve

Note:

1. The maximum furnace temperature of the module is 260°C, don't exceed this temperature.
2. The gold plating thickness of the module pad is 2u".

12WARNING

12.1 FCC WARNING

This device complies with part 15 of the FCC Rules. Operation is subject to the following two conditions: (1) this device may not cause harmful interference, and (2) this device must accept any interference received, including interference that may cause undesired operation.

Any changes or modifications not expressly approved by the party responsible for compliance could void the user's authority to operate the equipment.

NOTE: This equipment has been tested and found to comply with the limits for a Class B digital device, pursuant to Part 15 of the FCC Rules. These limits are designed to provide reasonable protection against harmful interference in a residential installation. This equipment generates, uses and can radiate radio frequency energy and, if not installed and used in accordance with the instructions, may cause harmful interference to radio communications. However, there is no guarantee that interference will not occur in a particular installation.

If this equipment does cause harmful interference to radio or television reception, which can be determined by turning the equipment off and on, the user is encouraged to try to correct the interference by one or more of the following measures:

- Reorient or relocate the receiving antenna.
- Increase the separation between the equipment and receiver.
- Connect the equipment into an outlet on a circuit different from that to which the receiver is connected.
- Consult the dealer or an experienced radio/TV technician for help.

To maintain compliance with FCC' s RF Exposure guidelines, This equipment should be installed and operated with minimum distance between 20cm the radiator your body: Use only the supplied antenna.

12.2 IC Caution

Radio Standards Specification RSS-Gen, issue 5

- English:

This device contains licence-exempt transmitter(s)/receiver(s) that comply with Innovation, Science and Economic Development Canada's licence-exempt RSS(s). Operation is subject to the following two conditions:

This device may not cause interference.

This device must accept any interference, including interference that may cause undesired operation of the device.

RF exposure statement:

The equipment complies with IC Radiation exposure limit set forth for uncontrolled environment. This equipment should be installed and operated with minimum distance 20cm between the radiator and your body.

- French:

Cet appareil contient des émetteurs / récepteurs exemptés de licence conformes aux RSS (RSS) d'Innovation, Sciences et Développement économique Canada. Le fonctionnement est soumis aux deux conditions suivantes:

Cet appareil ne doit pas causer d'interférences.

Cet appareil doit accepter toutes les interférences, y compris celles susceptibles de provoquer un fonctionnement indésirable de l'appareil.

Déclaration d'exposition RF:

L'équipement est conforme à la limite d'exposition aux radiations de la IC établie pour un environnement non contrôlé. Cet équipement doit être installé et utilisé avec une distance minimale de 20 cm entre le radiateur et votre corps.

13 Revision History

Revision	Release Date	Summary	Revised by
V1.0	2020-11-25	First release	Guo.QL
V1.1	2021-3-25	Updated Package Information and Warning	Ruan
V1.2	2021-4-28	Updated Module configurations	Ruan
V1.3	2021-8-23	Updated Module configurations and Photos	Ruan
V1.4	2021-9-13	Updated Features and Pin Definition	Ruan

OEM integration instructions:

This device is intended only for OEM integrators under the following conditions:

The transmitter module may not be co-located with any other transmitter or antenna. The module shall be only used with the external antenna(s) that has been originally tested and certified with this module.

As long as the conditions above are met, further transmitter test will not be required. However, the OEM integrator is still responsible for testing their end-product for any additional compliance requirements required with this module installed (for example, digital device emissions, PC peripheral requirements, etc.).

Validity of using the module certification:

In the event that these conditions cannot be met (for example certain laptop configurations or co-location with another transmitter), then the FCC/IC authorization for this module in combination with the host equipment is no longer considered valid and the FCC ID/IC of the module cannot be used on the final product. In these circumstances, the OEM integrator will be responsible for re-evaluating the end product (including the transmitter) and obtaining a separate FCC/IC authorization.

End product labeling:

The final end product must be labeled in a visible area with the following: "Contains Transmitter Module FCC ID: 2AMM6-8258FAT1HA. Contains IC: 26313-8258FAT1HA."

Information that must be placed in the end user manual:

The OEM integrator has to be aware not to provide information to the end user regarding how to install or remove this RF module in the user's manual of the end product which integrates this module. The end user manual shall include all required regulatory information/warning as show in this manual.

Integration instructions for host product manufacturers according to KDB 996369 D03 OEM Manual v01

2.2 List of applicable FCC/IC rules

FCC Part 15 Subpart C 15.247 & 15.207 & 15.209& RSS GEN&RSS 247

2.3 Specific operational use conditions

The module is a ZigBee module with 2.4G function.

Operation Frequency: 2405-2475MHz

Number of Channel: 15

Modulation: OQPSK

Type: PCB Antenna

Gain: 0.5 dBi Max.

The module can be used for mobile or applications with a maximum 0dBi antenna. The host manufacturer installing this module into their product must ensure that the final composite product complies with the FCC/IC requirements by a technical assessment or evaluation to the FCC/IC rules, including the transmitter operation. The host manufacturer has to be aware not to provide information to the end user regarding how to install or remove this RF module in the user's manual of the end product which integrates this module. The end user manual shall include all required regulatory information/warning as show in this manual.

2.4 Limited module procedures

Not applicable. The module is a Single module and complies with the requirement of FCC Part 15.212.

2.5 Trace antenna designs

Not applicable. The module has its own antenna, and doesn't need a host's printed board microstrip trace antenna etc.

2.6 RF exposure considerations

The module must be installed in the host equipment such that at least 20cm is maintained between the antenna and users' body; and if RF exposure statement or module layout is changed, then the host product manufacturer required to take responsibility of the module through a change in FCC ID/IC or new application. The FCC ID/IC of the module cannot be used on the final product. In these circumstances, the host manufacturer will be responsible for re-evaluating the end product (including the transmitter) and obtaining a separate FCC/IC authorization

2.7 Antennas

PCB Antenna

Type: OQPSK

Gain: 0.5dBi

This device is intended only for host manufacturers under the following conditions: The transmitter module may not be co-located with any other transmitter or antenna; The module shall be only used with the internal antenna(s) that has been originally tested and certified with this module. The antenna must be either permanently attached or employ a 'unique' antenna coupler.

As long as the conditions above are met, further transmitter test will not be required. However, the host manufacturer is still responsible for testing their end-product for any additional compliance requirements required with this module installed (for example, digital device emissions, PC peripheral requirements, etc.).

2.8 Label and compliance information

Host product manufacturers need to provide a physical or e-label stating "Contains FCC ID: 2AMM6-8258FAT1HA. Contains IC: 26313-8258FAT1HA." with their finished product.

2.9 Information on test modes and additional testing requirements

Operation Frequency: 2405~2475MHz

Number of Channel: 15

Modulation: OQPSK

Host manufacturer must perform test of radiated & conducted emission and spurious emission, etc. according to the actual test modes for a stand-alone modular transmitter in a host, as well as for multiple simultaneously transmitting modules or other transmitters in a host product. Only when all the test results of test modes comply with FCC requirements, then the end product can be sold legally.

2.10 Additional testing, Part 15 Subpart B disclaimer

The modular transmitter is only FCC/IC authorized for FCC Part 15 Subpart C 15.247 & 15.207 & 15.209 & RSS GEN&RSS 247 and that the host product manufacturer is responsible for compliance to any other FCC/IC rules that apply to the host not covered by the modular transmitter grant of certification. If the grantee markets their product as being Part 15 Subpart B/RSS GEN compliant (when it also contains unintentional-radiator digital circuitry), then the grantee shall provide a notice stating that the final host product still requires Part 15 Subpart B/ RSS GEN compliance testing with the modular transmitter installed.