

FCC Radio Test Report

FCC ID: 2AMLWHA12-5

FCC Part 15, Subpart C (15.231(a):2016)

Product	:	Remote control
Trade Name	:	HAOAI
Model No.	:	HA12-5
Series Model No.	:	HAYK-03, HA-188-Y1, HA-0507

Issued for

Chongqing HaoAi tech Development Co., Ltd

No. 6-2, lishuwan, Shapingba District, Chongqing, China

Issued by

Shenzhen ATL Testing Technology Co., Ltd.

F/4, Building 10, Dayuan Industrial Zone, Xili Town, Nanshan District, Shenzhen,
China

Tel.: +86-0755-26909822 Fax.: +86-0755-61605504

Website: www.atllab.org

Note: This report shall not be reproduced except in full, without the written approval of Shenzhen ATL Testing Technology Co., Ltd.. This document may be altered or revised by Shenzhen ATL Testing Technology Co., Ltd. personnel only, and shall be noted in the revision section of the document. The test results in the report only apply to the tested sample

TEST RESULT CERTIFICATION

Product : Remote control
Applicant..... : Chongqing HaoAi tech Development Co., Ltd
Address : No. 6-2, lishuwan, Shapingba District, Chongqing, China
Manufacturer..... : Chongqing HaoAi tech Development Co., Ltd
Address : No. 6-2, lishuwan, Shapingba District, Chongqing, China
Model No. : HA12-5
Standards : FCC Part 15, Subpart C (15.231(a):2016)
Test Method..... : ANSI C63.10: 2013

The above equipment has been tested by Shenzhen ATL Testing Technology Co., Ltd. and found compliance with the requirements set forth in the technical standards mentioned above. The results of testing in this report apply only to the product/system, which was tested. Other similar equipment will not necessarily produce the same results due to production tolerance and measurement uncertainties.

Test..... :

Date of receipt of test item 2017-06-20

Date(s) of performance of test 2017-06-21 to 2017-06-26

Test Result..... : **Pass**

Testing by : *Si feifei* Date : 2017-06-21
(Si feifei)

Check by : *Xie Lingling* Date : 2017-06-24
(Xie Lingling)

Approved by : *Xu Peng* Date : 2017-06-26
(Xu Peng)

Table of Contents	Page
1 . TEST SUMMARY	5
1.1 TEST FACILITY	6
1.2 MEASUREMENT UNCERTAINTY	6
2 . GENERAL INFORMATION	7
2.1 GENERAL DESCRIPTION OF EUT	7
2.2 DESCRIPTION OF TEST MODES	8
2.3 DESCRIPTION OF TEST SETUP	9
2.4 DESCRIPTION TEST PERIPHERAL AND EUT PERIPHERAL	10
2.5 EUT EXERCISE SOFTWARE	10
3 . CONDUCTED EMISSION TEST	11
3.1 CONDUCTED EMISSION MEASUREMENT (Frequency Range 150KHz-30MHz)	11
3.2 TEST PROCEDURE	11
3.3 TEST SETUP	12
3.4 TEST INSTRUMENTS	12
3.5 EUT OPERATING CONDITIONS	12
3.6 TEST RESULTS	12
RADIATED EMISSION MEASUREMENT	13
3.7 RADIATED EMISSION LIMIT (Frequency Range 9KHz-1000MHz)	13
3.8 TEST PROCEDURE	14
3.9 TEST SETUP	14
3.10 TEST INSTRUMENTS	16
3.11 EUT OPERATING CONDITIONS	16
3.12 TEST RESULTS	16
4 . OCCUPIED BANDWIDTH MEASUREMENT	18
4.1 LIMITS	18
4.2 TEST PROCEDURE	18
4.3 TEST SETUP	18
4.4 TEST INSTRUMENTS	19
4.5 EUT OPERATING CONDITIONS	19
4.6 TEST RESULTS	19
5 . RELEASE TIME MEASUREMENT	20
5.1 LIMITS	20
5.2 TEST PROCEDURE	20

Table of Contents	Page
5.3 TEST SETUP	20
5.4 TEST INSTRUMENTS	20
5.5 EUT OPERATING CONDITIONS	21
5.6 TEST RESULTS	21
6 . DUTY CYCLE	22
6.1 TEST STANDARD	22
6.2 TEST PROCEDURE	22
6.3 TEST SETUP	22
6.4 TEST INSTRUMENTS	22
6.5 EUT OPERATING CONDITIONS	23
6.6 TEST RESULTS	23
7 . ANTENNA REQUIREMENT	26
7.1 REQUIREMENT	26
7.2 ANTENNA CONNECTOR CONSTRUCTION	26

1. TEST SUMMARY

Test procedures according to the technical standards:

No.	Item	Specification	Results
1	Conducted Emission	FCC Part15.207	N/A(3)
2	Radiation Emission	FCC Part15.231(b)	PASS
3	20 dB Bandwidth	FCC Part15.231(c)	PASS
4	Release Time	FCC Part15.231(a)1	PASS
6	Duty Cycle	FCC Part15.231	PASS
6	Antenna Requirement	FCC Part15.203	PASS

NOTE:

(1) "N/A" denotes test is not applicable in this Test Report

(2) The test results of this report relate only to the tested sample(s) identified in this report.

(3) The EUT is powered by DC battery, no requirement for this test item.

1.1 TEST FACILITY

Shenzhen ATL Testing Technology Co., Ltd.

Add. : F/4, Building 10, Dayuan Industrial Zone, Xili Town, Nanshan District, Shenzhen, China

1.2 MEASUREMENT UNCERTAINTY

The reported uncertainty of measurement $y \pm U$, where expanded uncertainty U is based on a standard uncertainty multiplied by a coverage factor of $k=2$, providing a level of confidence of approximately **95** %.

A. Conducted Emission :

The measurement uncertainty is evaluated as ± 3.2 dB.

B. Radiated Measurement :

The measurement uncertainty is evaluated as ± 3.7 dB.

2. GENERAL INFORMATION

2.1 GENERAL DESCRIPTION OF EUT

Equipment	Remote control
Model Name	HA12-5
Additional Model Number(s)	HAYK-03, HA-188-Y1, HA-0507
Model Difference	All these models are identical in the same PCB, layout and electrical circuit, the only difference is model name for commercial.
Frequency Range	315MHz
Modulation Type	ASK
RF Output Power	89.98dBuV/m (PK Max.) 73.34 dBuV/m (AV Max.)
Antenna Type	PCB Antenna (Gain: 1 dBi)
Power Source	DC power by Battery.
Power Rating	DC 12V by 23A Battery.
Remark	More details EUT technical specifications, please refer to the User's Manual.

Note:

(1) This Test Report is FCC Part 15 Subpart C, 15.231(a) for 315MHz.

(2) Transmitting mode with antennas

Mode	TX Antenna (s)
315MHz	1

2.2 DESCRIPTION OF TEST MODES

To investigate the maximum EMI emission characteristics generates from EUT, the test system was pre-scanning tested base on the consideration of following EUT operation mode or test configuration mode which possible have effect on EMI emission level. Each of these EUT operation mode(s) or test configuration mode(s) mentioned above was evaluated respectively.

Test Items	Note
Conducted Emission	N/A
Radiated Emission	Continuously transmitting
Bandwidth	Continuously transmitting
Duty Cycle	Continuously transmitting
Release Time	Normal Mode

Note:

- (1) During the testing procedure, the continuously transmitting mode was programmed by the customer.
- (2) By preliminary testing and verifying three axis (X, Y and Z) position of EUT transmitted status, it was found that "X axis" position was the worst, then the final test was executed the worst condition and test data were recorded in this report.

2.3 DESCRIPTION OF TEST SETUP

Radiated Emission

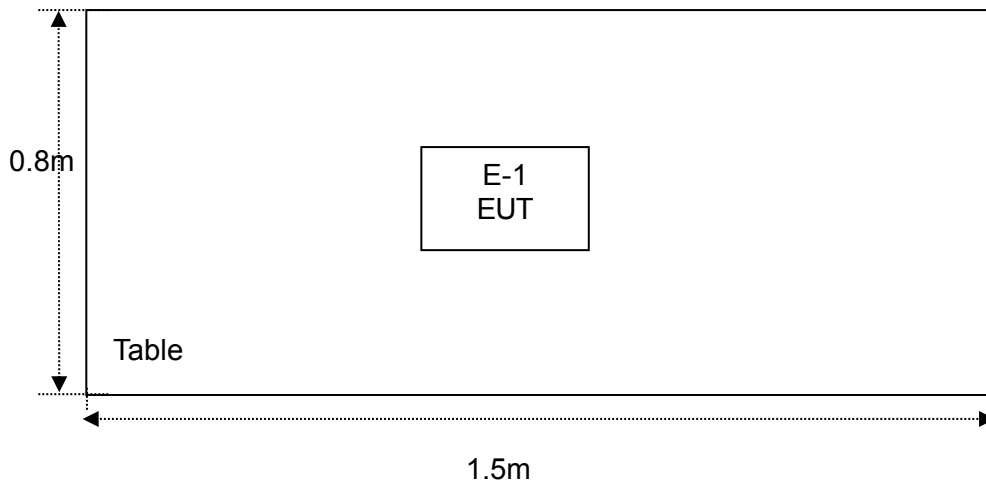

2.4 DESCRIPTION TEST PERIPHERAL AND EUT PERIPHERAL

The EUT has been tested as an independent unit together with other necessary accessories or support units. The following support units or accessories were used to form a representative test configuration during the tests.

Item	Equipment	Mfr/Brand	Model/Type No.	Note
E-1	Remote control	N/A	HA12-5	EUT

Item	Shielded Type	Ferrite Core	Length	Note

Note:

- (1) The support equipment was authorized by Declaration of Confirmation.
- (2) For detachable type I/O cable should be specified the length in cm in 『Length』 column.
- (3) “YES” means “shielded” “with core”; “NO” means “unshielded” “without core”.

2.5 EUT EXERCISE SOFTWARE

Power Parameters for Testing	
Test Software Version	N/A
Mode	Frequency/ Parameters
TX Mode	315MHz
	DEF

3. CONDUCTED EMISSION TEST

3.1 CONDUCTED EMISSION MEASUREMENT (Frequency Range 150KHz-30MHz)

FREQUENCY (MHz)	Quasi-peak	Average
	dBuV	dBuV
0.15 -0.5	66 - 56 *	56 - 46 *
0.50 -5.0	56.00	46.00
5.0 -30.0	60.00	50.00

Note:

- (1) The tighter limit applies at the band edges.
- (2) The limit of " * " marked band means the limitation decreases linearly with the logarithm of the frequency in the range.

The following table is the setting of the receiver

Receiver Parameters	Setting
Attenuation	10 dB
Start Frequency	0.15 MHz
Stop Frequency	30 MHz
IF Bandwidth	9 kHz

3.2 TEST PROCEDURE

- a. The EUT was placed 0.8 meters from the horizontal ground plane with EUT being connected to the power mains through a line impedance stabilization network (LISN). All other support equipments powered from additional LISN(s). The LISN provide 50 Ohm/ 50uH of coupling impedance for the measuring instrument.
- b. Interconnecting cables that hang closer than 40 cm to the ground plane shall be folded back and forth in the center forming a bundle 30 to 40 cm long.
- c. I/O cables that are not connected to a peripheral shall be bundled in the center. The end of the cable may be terminated, if required, using the correct terminating impedance. The overall length shall not exceed 1 m.
- d. LISN at least 80 cm from nearest part of EUT chassis.
- e. For the actual test configuration, please refer to the related Item –EUT Test Photos.

3.3 TEST SETUP

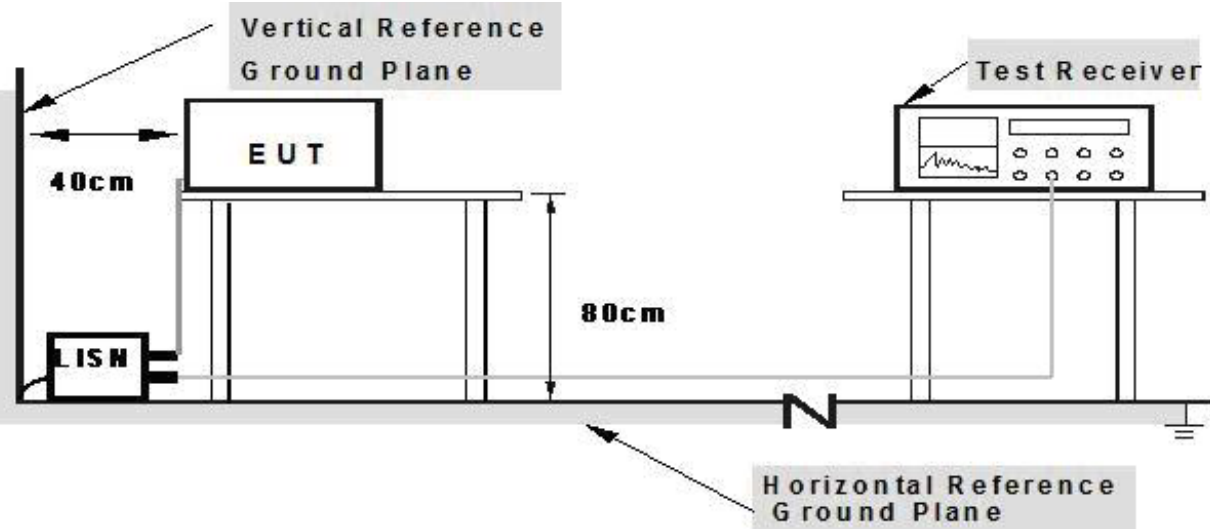

- Note: 1. Support units were connected to second LISN.**
2. Both of LISNs (AMN) are 80 cm from EUT and at least 80 from other units and other metal planes

3.4 TEST INSTRUMENTS

Equipment	Manufacturer	Type No.	Serial No.	Last calibration	Calibrated until	Calibration period
LISN	R&S	NSLK81	8126466	Jul. 04, 2016	Jul. 03. 2017	1 year
LISN	R&S	NSLK81	8126487	Jul. 04, 2016	Jul. 03. 2017	1 year
50Ω Switch	ANRITSU CORP	MP59B	6200983704	Jul. 04, 2016	Jul. 03. 2017	1 year
Test Cable	N/A	C01	N/A	Jul. 04, 2016	Jul. 03. 2017	1 year
Test Cable	N/A	C02	N/A	Jul. 04, 2016	Jul. 03. 2017	1 year
Test Cable	N/A	C03	N/A	Jul. 04, 2016	Jul. 03. 2017	1 year
EMI Test Receiver	R&S	ESCI	1166.595	Jul. 04, 2016	Jul. 03. 2017	1 year
Passive Voltage Probe	ESH2-Z3	R&S	100196	Jul. 04, 2016	Jul. 03. 2017	1 year

3.5 EUT OPERATING CONDITIONS

The EUT tested system was configured as the statements of 2.3 Unless otherwise a special operating condition is specified in the follows during the testing.

3.6 TEST RESULTS

The EUT is power by DC Battery, no requirement for this test item.

RADIATED EMISSION MEASUREMENT

3.7 RADIATED EMISSION LIMIT (Frequency Range 9KHz-1000MHz)

According to 15.231(a), the field strength of emissions from intentional radiators operated under this Section shall not exceed the following:

Fundamental Frequency (MHz)	Field Strength of Fundamental (microvolt/meter) at 3m	Field Strength of Spurious Emissions (microvolt/meter) at 3m
40.66~40.70	2250	225
70~130	1250	125
130~174	1250 to 3750(**)	125 to 375(**)
174~260	3750	375
260~470	3750 to 12500(**)	375 to 1250(**)
Above 470	12500	1250

** Linear interpolations, the formulas for calculating the maximum permitted fundamental field strengths are as follows:

(1) for the band 130~174 MHz, uV/m at 3 meters= 56.81818(F)-6136.3636;

(2) for the band 260~470 MHz, uV/m at 3 meter= 41.6667(F)-7083.3333.

20 dBc in any 100 kHz bandwidth outside the operating frequency band. In case the emission fall within the restricted band specified on 15.205(a) and RSS-210 Section 2.2&A8.5, then the 15.209(a) and RSS-General limit in the table below has to be followed.

FREQUENCY (MHz)	Field Strength (uV/m at meter)	Measurement Distance (meters)
0.009 -0.490	2400/F(KHz)	300
0.490 -1.705	24000/F(KHz)	30
1.705 -30.0	30	30
30 -88	100	3
88 -216	150	3
216~960	200	3
Above 960	500	3

RADIATED EMISSION LIMITS (Above 1000MHz)

FREQUENCY (MHz)	3M Distance(dBuV/m)	
	Peak	Average
Above 1000	74	54

Note:

(1) The limit for radiated test was performed according to FCC PART 15C.

(2) The tighter limit applies at the band edges.

(2) Emission Level(dBuV/m)=20log Emission Level(uV/m)

The following table is the setting of the receiver

Receiver Parameter	Setting
Attenuation	Auto
Start Frequency~ Stop Frequency	9kHz~150kHz/ RB 200Hz for QP
Start Frequency~ Stop Frequency	150kHz~30MHz/ RB 9kHz for QP
Start Frequency~ Stop Frequency	30MHz~1000MHz/ RB120kHz for QP

The following table is the setting of the spectrum

Spectrum Parameter	Setting
Attenuation	Auto
Start Frequency	1000 MHz
Stop Frequency	10 th carrier harmonic
RB/ VB (emission in restricted band)	1MHz/ 3 MHz for Peak, 1MHz/ 10Hz for Average

3.8 TEST PROCEDURE

- a. The measuring distance of at 3 m shall be used for measurements at frequency up to 1GHz. For frequencies above 1GHz, any suitable measuring distance may be used.
- b. The EUT was placed on the top of a rotating table 0.8 meters above the ground at a 3 meter open area test site. The table was rotated 360 degrees to determine the position of the highest radiation.
- c. The height of the equipment or of the substitution antenna shall be 0.8 m; the height of the test antenna shall vary between 1 m to 4 m. Both horizontal and vertical polarizations of the antenna are set to make the measurement.
- d. The initial step in collecting conducted emission data is a spectrum analyzer peak detector mode pre-scanning the measurement frequency range. Significant peaks are then marked and then Quasi Peak detector mode re-measured, above 1G Average detector mode will be instead.
- e. If the Peak Mode measured value compliance with and lower than Quasi Peak Mode Limit, the EUT shall be deemed to meet QP Limits and then no additional QP Mode measurement performed.
- f. For the actual test configuration, please refer to the related Item –EUT Test Photos.

Note:

Both horizontal and vertical antenna polarities were tested.

And performed pretest to three orthogonal axis. The worst case emissions were reported.

3.9 TEST SETUP

(A) Radiated Emission Test Set-Up Frequency Below 30MHz

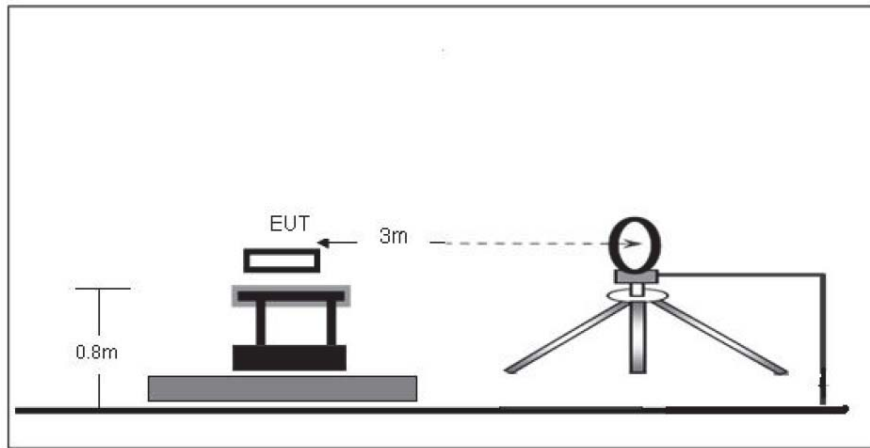

(B) Radiated Emission Test Set-Up Frequency Below 1 GHz

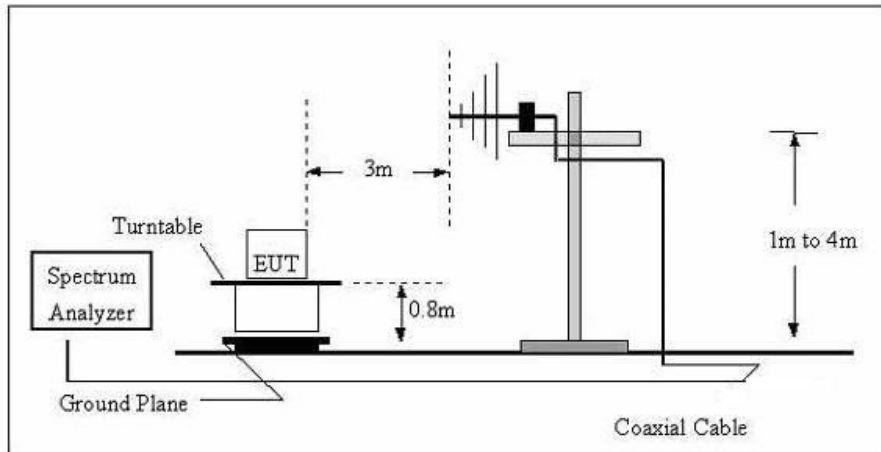

(C) Radiated Emission Test Set-Up Frequency Above 1GHz

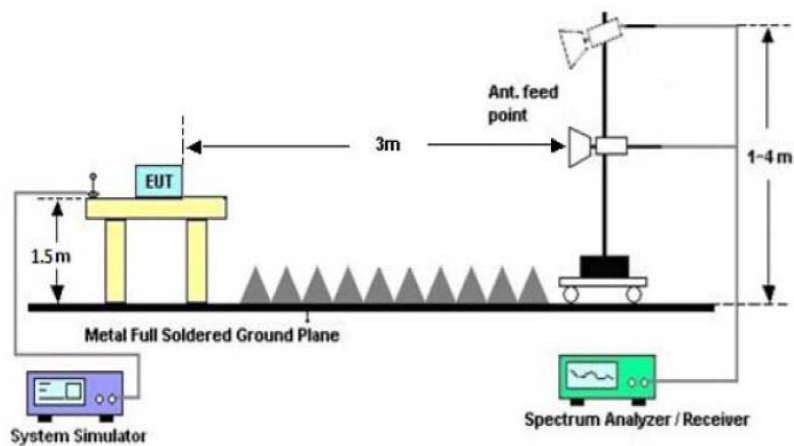

3.10 TEST INSTRUMENTS

Equipment	Manufacturer	Type No.	Serial No.	Last calibration	Calibrated until	Calibration period
Broadband Antenna	R&S	VULB 9168	VULB 9168-456	Jul. 04, 2016	Jul. 03. 2017	1 year
Test Cable	N/A	R-01	N/A	Jul. 04, 2016	Jul. 03. 2017	1 year
Test Cable	N/A	R-02	N/A	Jul. 04, 2016	Jul. 03. 2017	1 year
EMI Test Receiver	R&S	ESCI	101324	Jul. 04, 2016	Jul. 03. 2017	1 year
Antenna Mast	EM	SC100_1	N/A	N/A	N/A	N/A
Turn Table	EM	SC100	060531	N/A	N/A	N/A
50Ω Switch	Anritsu Corp	MP59B	6200983705	Jul. 04, 2016	Jul. 03. 2017	1 year
Spectrum Analyzer	R&S	FSP40	100154	Jul. 04, 2016	Jul. 03. 2017	1 year
Horn Antenna	R&S	HF906	10029	Jul. 04, 2016	Jul. 03. 2017	1 year
Amplifier	EM	EM-30180	060538	Jul. 04, 2016	Jul. 03. 2017	1 year

3.11 EUT OPERATING CONDITIONS

The EUT tested system was configured as the statements of **2.3** Unless otherwise a special operating condition is specified in the follows during the testing.

3.12 TEST RESULTS

TEST RESULTS (9KHz~ 30MHz)

Note: The amplitude of spurious emissions which are attenuated by more than 20d below the permissible value has no need to be reported.

Fundamental and Harmonics emissions(30MHz-4G)

EUT :	Remote control			Model Name. :	HA12-5		
Temperature :	26 °C			Relative Humidity :	56%		
Test Power :	DC 12V			Pressure :	1010 hPa		
Test Mode :	TX Mode			Test Date :	2017-06-23		
Freq.	Deceiver Reading	Detector	Polar	Corrected Factor	Emission Level	Limit	Margin
MHz	dBuV	Peak/Avg	H/V	dB	dBuV /m	dBuV /m	dB
100.5806	26.94	Peak	H	-11.46	15.48	43.50	-28.02
315.1375	90.62	Peak	H	-9.64	80.98	95.62	-14.64
315.1375	82.98	Avg	H	-9.64	73.34	75.62	-2.28
630.0982	68.31	Peak	H	-9.35	58.96	75.63	-16.67
630.0982	60.66	Avg	H	-9.35	51.31	55.62	-4.31
945.2750	58.48	Peak	H	1.49	59.97	75.62	-15.65
945.2750	50.84	Avg	H	1.49	52.33	55.62	-3.29
1259.9125	55.79	Peak	H	0.53	56.32	74.00	-17.68
1259.9125	48.15	Avg	H	0.53	48.68	54.00	-5.32
200.6881	27.26	Peak	V	-11.63	15.63	43.50	-27.87
315.1375	86.27	Peak	H	-9.64	76.63	95.62	-18.99
315.1375	78.63	Avg	H	-9.64	68.99	75.62	-6.63
630.0982	65.58	Peak	H	-9.35	56.23	75.63	-19.4
630.0982	57.94	Avg	H	-9.35	48.59	55.62	-7.03
945.2750	53.69	Peak	H	1.49	55.18	75.62	-20.44
945.2750	46.05	Avg	H	1.49	47.54	55.62	-8.08
1259.9125	54.14	Peak	H	0.53	54.67	74.00	-19.33
1259.9125	46.50	Avg	H	0.53	47.03	54.00	-6.97

Remark:

Emission Level= Read Level+ Correct Factor

Margin= Emission Level-Limit

Peak=Avg+7.64

The testing has been conformed to 10th harmonics(1G~4G)

Other harmonics emission are lower then 20dB below the allowable Limit

Other harmonics emissions are lower than 20dB below the allowable limit.

- Note:**
- (1) All Readings are Peak Value and AV. And AV is calculated by the following:
Testing frequency range below 1GHz the measuring instrument use VBW=120 kHz with Quasi-peak detection.
Testing frequency range above 1GHz the measuring instrument use RBW=1 MHz and VBW=3 MHz with Peak Detector for Peak Values.
Average Values=Peak Values+20log (Duty Cycle)
 - (2) Emission Level= Reading Level + Probe Factor +Cable Loss
 - (3) Data of measurement within this frequency range shown "--" in the table above means the reading of emissions are attenuated more than 20dB below the permissible limits or the field strength is too small to be measured.

Pulse Desensitization Correction Factor

Note:

(1)The Smallest Pulse Width (PW)= 0.4ms

(2) 2/PW=2/0.4(ms)= 5kHz<100 kHz

Because 2/PW<RBW, so the PDCF is not needed.

4. OCCUPIED BANDWIDTH MEASUREMENT

4.1 LIMITS

The 20dB bandwidth of the emissions shall be no wider than 0.25% of the center frequency for devices operating above 70 MHz and below 900 MHz. So the emission bandwidth limits have been calculated in below table.

Fundamental Frequency	20 dB Bandwidth Limits (MHz)
315 MHz	0.7875

4.2 TEST PROCEDURE

The EUT was directly connected to the power meter and antenna output port as show in the block diagram as bellow.

Spectrum Parameters	Setting
Attenuation	Auto
RBW	10 kHz
VBW	$\geq 3\text{RBW}$
Detector	Peak
Trace	Max Hold
Sweep Time	Auto

4.3 TEST SETUP

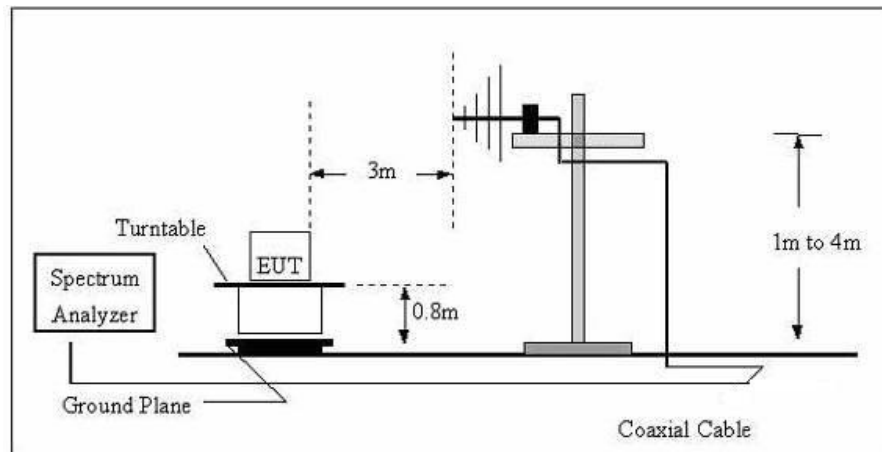

4.4 TEST INSTRUMENTS

Equipment	Manufacturer	Type No.	Serial No.	Last calibration	Calibrated until	Calibration period
Broadband Antenna	R&S	VULB 9168	VULB 9168-456	Jul. 04, 2016	Jul. 03. 2017	1 year
Test Cable	N/A	R-01	N/A	Jul. 04, 2016	Jul. 03. 2017	1 year
Test Cable	N/A	R-02	N/A	Jul. 04, 2016	Jul. 03. 2017	1 year
EMI Test Receiver	R&S	ESCI	101324	Jul. 04, 2016	Jul. 03. 2017	1 year
Antenna Mast	EM	SC100_1	N/A	N/A	N/A	N/A
Turn Table	EM	SC100	060531	N/A	N/A	N/A
50Ω Switch	Anritsu Corp	MP59B	6200983705	Jul. 04, 2016	Jul. 03. 2017	1 year
Spectrum Analyzer	R&S	FSP40	100154	Jul. 04, 2016	Jul. 03. 2017	1 year
Horn Antenna	R&S	HF906	10029	Jul. 04, 2016	Jul. 03. 2017	1 year
Amplifier	EM	EM-30180	060538	Jul. 04, 2016	Jul. 03. 2017	1 year

4.5 EUT OPERATING CONDITIONS

The EUT was set to continuously transmitting in the maximum power during the test.

4.6 TEST RESULTS

Frequency (MHz)	20dB Bandwidth (MHz)	Limit (MHz)	Result
315	0.456	0.7875	PASS

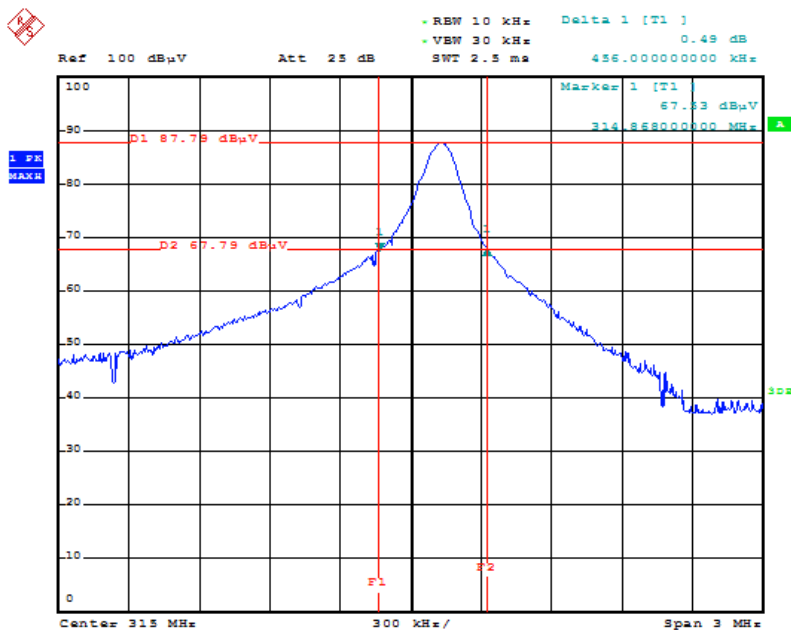

Date: 24.JUN.2017 13:06:18

5. RELEASE TIME MEASUREMENT

5.1 LIMITS

According to FCC 15.231(a), A manually operated transmitter shall employ a switch that will automatically deactivate the transmitter within not more than 5 seconds of being released.

5.2 TEST PROCEDURE

The EUT was directly connected to the power meter and antenna output port as show in the block diagram as below.

Spectrum Parameters	Setting
Span	0MHz
RBW	100 kHz
VBW	$\geq 3\text{RBW}$
Detector	Peak
Trace	Max Hold
Sweep Time	5S

5.3 TEST SETUP

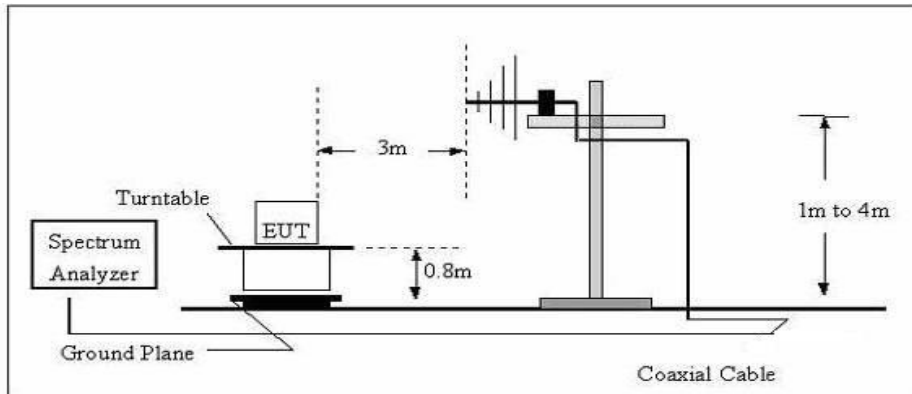

5.4 TEST INSTRUMENTS

Equipment	Manufacturer	Type No.	Serial No.	Last calibration	Calibrated until	Calibration period
Broadband Antenna	R&S	VULB 9168	VULB 9168-456	Jul. 04, 2016	Jul. 03. 2017	1 year
Test Cable	N/A	R-01	N/A	Jul. 04, 2016	Jul. 03. 2017	1 year
Test Cable	N/A	R-02	N/A	Jul. 04, 2016	Jul. 03. 2017	1 year
EMI Test Receiver	R&S	ESCI	101324	Jul. 04, 2016	Jul. 03. 2017	1 year
Antenna Mast	EM	SC100_1	N/A	N/A	N/A	N/A
Turn Table	EM	SC100	060531	N/A	N/A	N/A
50Ω Switch	Anritsu Corp	MP59B	6200983705	Jul. 04, 2016	Jul. 03. 2017	1 year
Spectrum Analyzer	R&S	FSP40	100154	Jul. 04, 2016	Jul. 03. 2017	1 year
Horn Antenna	R&S	HF906	10029	Jul. 04, 2016	Jul. 03. 2017	1 year
Amplifier	EM	EM-30180	060538	Jul. 04, 2016	Jul. 03. 2017	1 year

5.5 EUT OPERATING CONDITIONS

The EUT was set to continuously transmitting during the test.

5.6 TEST RESULTS

Frequency (MHz)	Transmission Time (s)	Limit (s)	Result
315	0.18	5	Pass

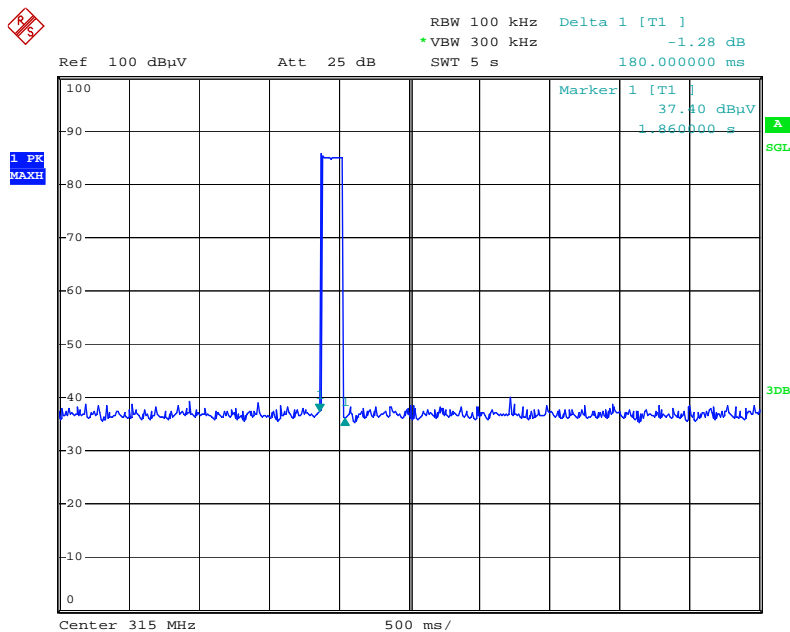

Date: 24.JUN.2017 13:08:20

6. DUTY CYCLE

6.1 TEST STANDARD
FCC 15.231

6.2 TEST PROCEDURE

- A, The EUT was placed on a turntable which is 0.8m above ground plane.
- B, Set EUT operating in continuous transmitting mode.
- C, Set the Spectrum Analyzer to the transmitter carrier frequency, and set the spectrum analyzer resolution bandwidth (RBW) to 100 kHz and video bandwidth (VBW) to 300 kHz, Span was set to 0 Hz.
- D, The Duty Cycle was measured and recorded.

6.3 TEST SETUP

(A) Radiated Emission Test Set-Up

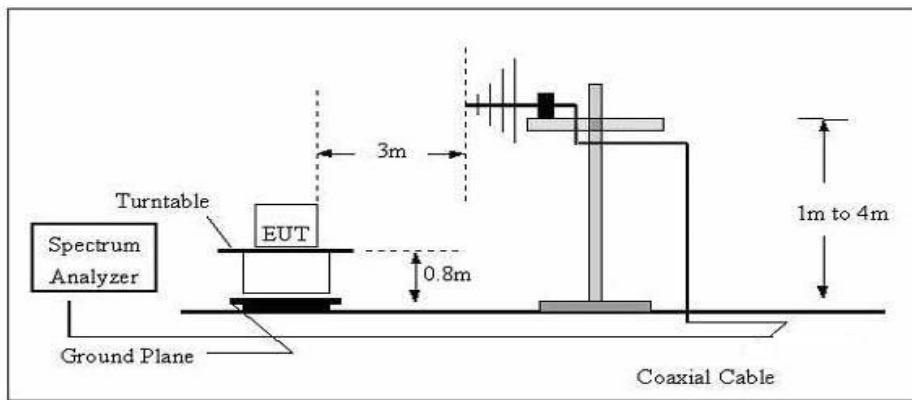

6.4 TEST INSTRUMENTS

Equipment	Manufacturer	Type No.	Serial No.	Last calibration	Calibrated until	Calibration period
Broadband Antenna	R&S	VULB 9168	VULB 9168-456	Jul. 04, 2016	Jul. 03. 2017	1 year
Test Cable	N/A	R-01	N/A	Jul. 04, 2016	Jul. 03. 2017	1 year
Test Cable	N/A	R-02	N/A	Jul. 04, 2016	Jul. 03. 2017	1 year
EMI Test Receiver	R&S	ESCI	101324	Jul. 04, 2016	Jul. 03. 2017	1 year
Spectrum Analyzer	Agilent	E4407B	MY41440432	Jul. 04, 2016	Jul. 03. 2017	1 year
Antenna Mast	EM	SC100_1	N/A	N/A	N/A	N/A
Turn Table	EM	SC100	060531	N/A	N/A	N/A
50Ω Switch	Anritsu Corp	MP59B	6200983705	Jul. 04, 2016	Jul. 03. 2017	1 year
Spectrum Analyzer	R&S	FSP40	100154	Jul. 04, 2016	Jul. 03. 2017	1 year
Horn Antenna	R&S	HF906	10029	Jul. 04, 2016	Jul. 03. 2017	1 year
Amplifier	EM	EM-30180	060538	Jul. 04, 2016	Jul. 03. 2017	1 year

6.5 EUT OPERATING CONDITIONS

The EUT was set to continuously transmitting in the maximum power during the test.

6.6 TEST RESULTS

Please refer the following pages:

Plot 1/Plot 2: transmit once in 100ms, and each cycle is 41.6 ms there are two kinds of pulse in each cycle, the large pulses total 11, the small pulses total 14.

Plot 3: one large pulse in a time period of 1.06 ms

Plot 4: one small pulse in a time period of 0.40 ms.

Duty Cycle=ON/Total=(11*1.06+14*0.4)/41.6=17.26/41.6=41.49%

20 log(Duty Cycle)=-7.64

Average=Peak Value+ 20log(Duty Cycle), AV=PK-7.64

Plot 1

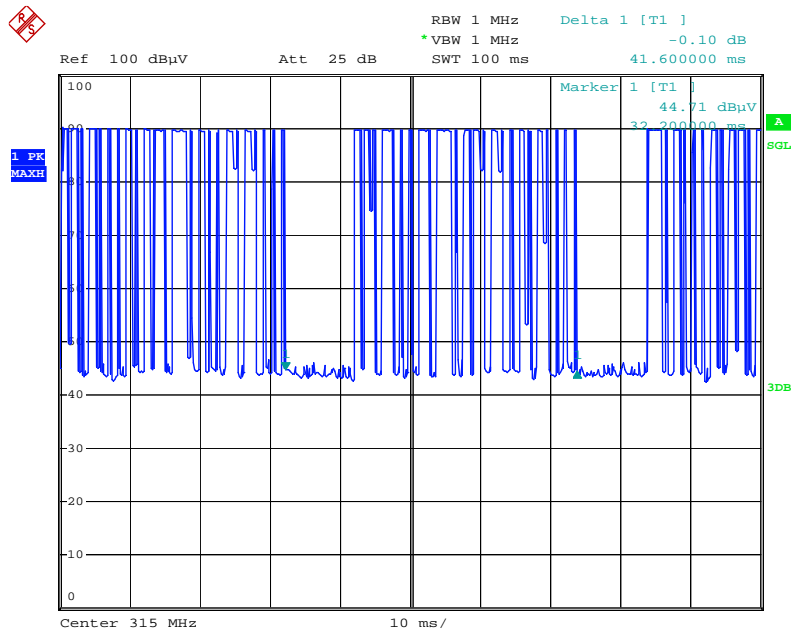

Date: 24.JUN.2017 13:11:08



Plot 2

RBW 1 MHz
*VBW 1 MHz
SWT 40 ms

Ref 100 dBµV

Att 25 dB

1 PK
MAXH

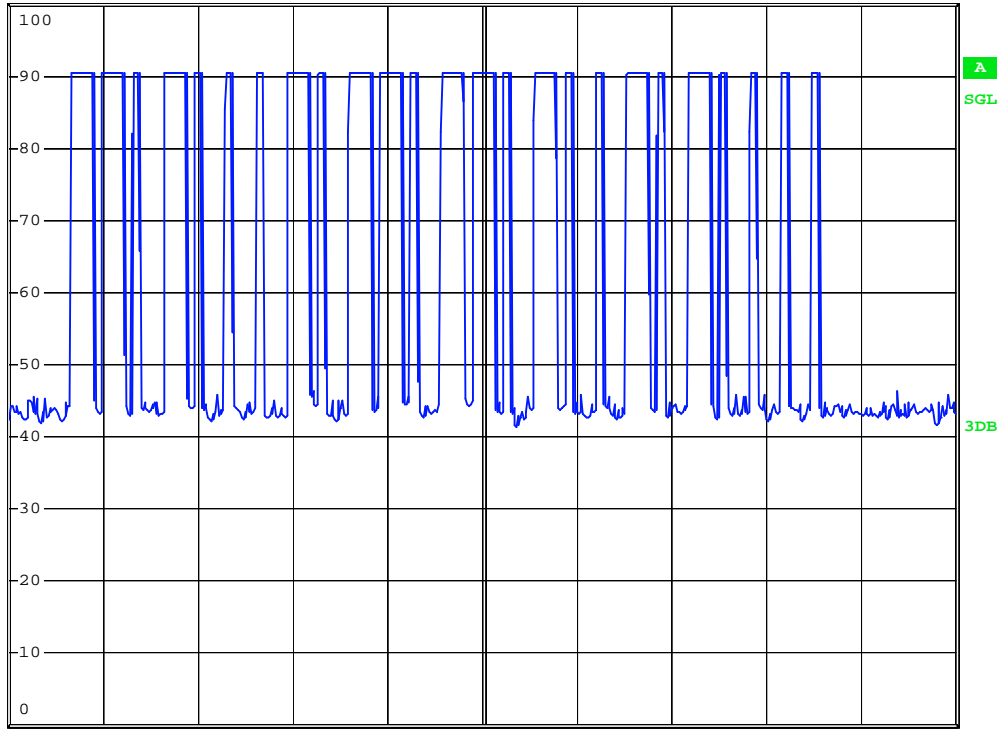

Date: 24.JUN.2017 13:11:46

Plot 3

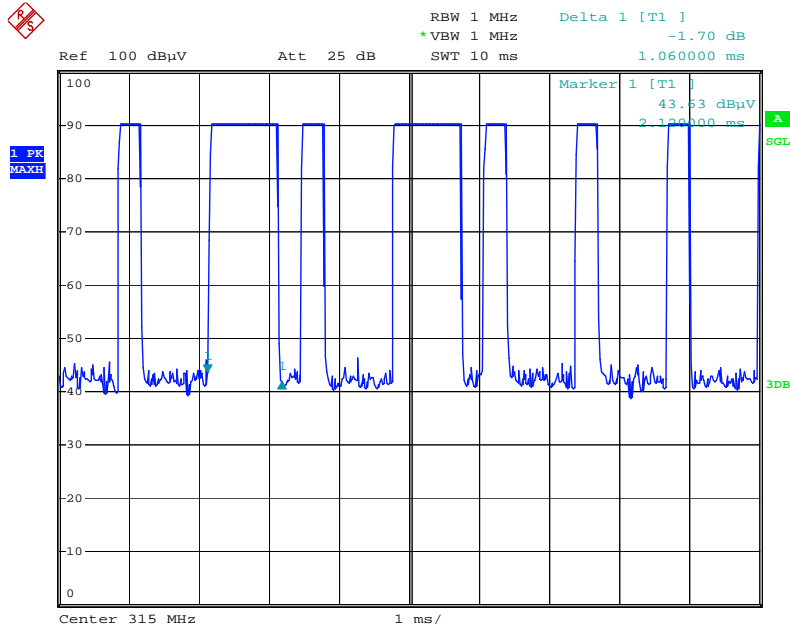

Date: 24.JUN.2017 13:13:25

Plot 4

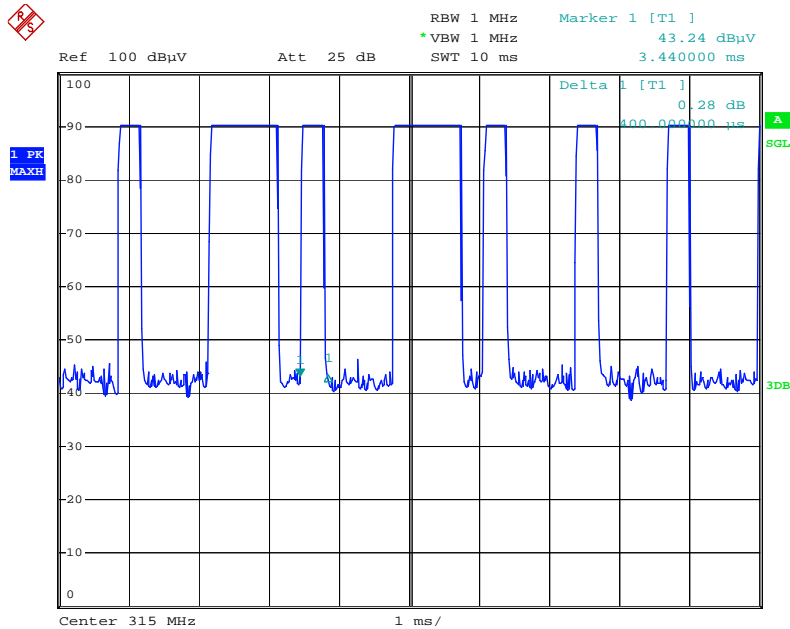

Date: 24.JUN.2017 13:13:53

7. ANTENNA REQUIREMENT

7.1 REQUIREMENT

Antenna Requirement (15.203)	An intentional radiator shall be designed to ensure that no antenna other than that furnished by the responsible party shall be used with the device. The use of a permanently attached antenna or of an antenna that uses a unique coupling to the intentional radiator shall be considered sufficient to comply with the provisions of this Section. The manufacturer may design the unit so that a broken antenna can be replaced by the user, but the use of a standard antenna jack or electrical connector is prohibited.
---------------------------------	---

7.2 ANTENNA CONNECTOR CONSTRUCTION

The EUT antenna is a PCB Antenna. And the maximum gain of this antenna is 1 dBi. It complies with the standard requirement.

-----END OF REPORT-----