



TEST REPORT

APPLICANT : Shenzhen Jimi IOT Co., Ltd
PRODUCT NAME : Container GPS Tracker
MODEL NAME : CT10
BRAND NAME : N/A
FCC ID : 2AMLFCT10
STANDARD(S) : 47 CFR Part 22 Subpart H
: 47 CFR Part 24 Subpart E
TEST DATE : 2018-09-27 to 2018-10-17
ISSUE DATE : 2018-10-18

Tested by: Gao Mingzhou
Gao Mingzhou (Test Engineer)

Approved by: Peng Huarui
Peng Huarui (Supervisor)

NOTE: This document is issued by MORLAB, the test report shall not be reproduced except in full without prior written permission of the company. The test results apply only to the particular sample(s) tested and to the specific tests carried out which is available on request for validation and information confirmed at our website.





DIRECTORY

1. Technical Information	4
1.1. Applicant and Manufacturer Information	4
1.2. Equipment Under Test (EUT) Description	4
1.3. Test Standards and Results	6
1.4. Environmental Conditions	6
2. 47 CFR Part 2, Part 22H & 24E Requirements	7
2.1. Conducted RF Output Power	7
2.2. Peak to Average Ratio	10
2.3. 99% Occupied Bandwidth	20
2.4. Frequency Stability	26
2.5. Conducted Out of Band Emissions	30
2.6. Band Edge	37
2.7. Transmitter Radiated Power (EIRP/ERP)	41
2.8. Radiated Out of Band Emissions	48
Annex A Test Uncertainty	69
Annex B Testing Laboratory Information	70



Change History		
Issue	Date	Reason for change
1.0	2018-10-18	First edition



1. Technical Information

Note: Provide by applicant.

1.1. Applicant and Manufacturer Information

Applicant:	Shenzhen Jimi IOT Co., Ltd
Applicant Address:	4/F, Building C, Gaoxinqi Industrial Park, Liuxian 1st Road, No.67 Xin'an Street, Bao'an District, Shenzhen, China
Manufacturer:	Shenzhen Jimi IOT Co., Ltd
Manufacturer Address:	4/F, Building C, Gaoxinqi Industrial Park, Liuxian 1st Road, No.67 Xin'an Street, Bao'an District, Shenzhen, China

1.2. Equipment Under Test (EUT) Description

Product Name:	Container GPS Tracker
Serial No:	(N/A, marked #1 by test site)
Hardware Version:	V2.0
Software Version:	NFC117_V0003_20180705
Modulation Type:	GPRS Mode with GMSK Modulation EDGE Mode with 8PSK Modulation WCDMA Mode with QPSK Modulation
Operating Frequency Range:	GSM 850MHz: Tx: 824.20 - 848.80MHz (at intervals of 200kHz); Rx: 869.20 - 893.80MHz (at intervals of 200kHz) GSM 1900MHz: Tx: 1850.20 - 1909.80MHz (at intervals of 200kHz); Rx: 1930.20 - 1989.80MHz (at intervals of 200kHz) WCDMA 850MHz Tx: 826.4 - 846.6MHz (at intervals of 200kHz); Rx: 871.4 - 891.6MHz (at intervals of 200kHz) WCDMA 1900MHz Tx: 1852.4 - 1907.6MHz (at intervals of 200kHz); Rx: 1932.4 - 1987.6MHz (at intervals of 200kHz)
Multi-slot Class:	GPRS: Multislot Class12; EGPRS: Multislot Class12
Emission Designators:	GPRS 850:250KGXW, GPRS 1900:255KGXW EGPRS850:250KG7W, EGPRS1900:248KG7W, WCDMA 850:4M11F9W , WCDMA1900:4M12F9W



Antenna Type:	Monopole Antenna	
Antenna Gain:	GSM/WCDMA 850	0.6 dBi
	GSM/WCDMA 1900	0 dBi
Operating voltage:	Normal(NV)	5.0V
	Lowest(LV)	4.8V
	Highest(HV)	5.2V

Note 1: The transmitter (Tx) frequency arrangement of the Cellular 850MHz band used by the EUT can be represented with the formula $F(n)=824.2+0.2*(n-128)$, $128 \leq n \leq 251$; the lowest, middle, highest channel numbers (ARFCHs) used and tested in this report are separately 128 (824.2MHz), 190 (836.6MHz) and 251 (848.8MHz).

Note 2: The transmitter (Tx) frequency arrangement of the PCS 1900MHz band used by the EUT can be represented with the formula $F(n)=1850.2+0.2*(n-512)$, $512 \leq n \leq 810$; the lowest, middle and highest channel numbers (ARFCHs) used and tested in this report are separately 512 (1850.2MHz), 661 (1880.0MHz) and 810 (1909.8MHz).

Note 3: The transmitter (Tx) frequency arrangement of the WCDMA 850MHz band used by the EUT can be represented with the formula $F(n)=826.4+0.2*(n-4132)$, $4132 \leq n \leq 4233$; the lowest, middle and highest channel numbers (ARFCHs) used and tested in this report are separately 4132 (826.4MHz), 4175(835MHz) and 4233 (846.6MHz).

Note 4: The transmitter (Tx) frequency arrangement of the WCDMA 1900MHz band used by the EUT can be represented with the formula $F(n)=1852.4+0.2*(n-9262)$, $9262 \leq n \leq 9538$; the lowest, middle and highest channel numbers (ARFCHs) used and tested in this report are separately 9262 (1852.4MHz), 9400 (1880MHz) and 9538 (1907.6MHz).

Note 5: For a more detailed description, please refer to Specification or User's Manual supplied by the applicant and/or manufacturer.



1.3. Test Standards and Results

The objective of the report is to perform testing according to 47 CFR Part 2, Part 22, Part 24 for the EUT FCC ID Certification:

No	Identity	Document Title
1	47 CFR Part 2 (10-1-12 Edition)	Frequency Allocations and Radio Treaty Matters; General Rules and Regulations
2	47 CFR Part 22 (10-1-12 Edition)	Public Mobile Services
3	47 CFR Part 24 (10-1-12 Edition)	Personal Communications Services

Test detailed items/section required by FCC rules and results are as below:

No.	Section	Description	Test Date	Test Engineer	Result
1	2.1046	Conducted RF Output Power	Sep 27, 2018	Gao Mingzhou	PASS
2	24.232(d)	Peak - Average Radio	Sep 27, 2018	Gao Mingzhou	PASS
3	2.1049	99% Occupied Bandwidth	Sep 27, 2018	Gao Mingzhou	PASS
4	2.1055, 22.355, 24.235	Frequency Stability	Oct 16, 2018	Gao Mingzhou	PASS
5	2.1051, 22.917(a), 24.238(a)	Conducted Out of Band Emissions	Sep 27, 2018 Oct 17, 2018	Gao Mingzhou	PASS
6	2.1051, 22.917(a), 24.238(a)	Band Edge	Sep 27, 2018 Oct 17, 2018	Gao Mingzhou	PASS
7	22.913(a), 24.232(a)	Transmitter Radiated Power (EIPR/ERP)	Sep 28, 2018 Oct 09, 2018	Zheng Fengjian	PASS
8	2.1051, 22.917(a), 24.238(a)	Radiated Out of Band Emissions	Oct 17, 2018	Zheng Fengjian	PASS

Note: The tests were performed according to the method of measurements prescribed in KDB971168 D01 v03 (Oct 27, 2017) and ANSI/TIA-603-E-2016.

1.4. Environmental Conditions

During the measurement, the environmental conditions were within the listed ranges:

Temperature (°C):	15 - 35
Relative Humidity (%):	30 -60
Atmospheric Pressure (kPa):	86-106



2.1.3. Test Results

The lowest, middle and highest channels are selected to perform testing to verify the conducted RF output power of the EUT.

GSM850	Average Power (dBm)			Verdict
	128	190	251	
TX Channel	128	190	251	Verdict
Frequency (MHz)	824.2	836.6	848.8	
GPRS 1 Tx slot	31.86	31.92	31.98	PASS
GPRS 2 Tx slots	29.64	29.76	29.86	PASS
GPRS 3 Tx slots	27.54	27.72	27.86	PASS
GPRS 4 Tx slots	25.31	25.49	25.62	PASS
EDGE 1 Tx slot	25.43	25.66	25.81	PASS
EDGE 2 Tx slots	25.03	25.24	25.40	PASS
EDGE 3 Tx slots	23.46	23.41	23.53	PASS
EDGE 4 Tx slots	20.78	20.98	21.15	PASS

GSM1900	Average Power (dBm)			Verdict
	512	661	810	
TX Channel	512	661	810	Verdict
Frequency (MHz)	1850.2	1880	1909.8	
GPRS 1 Tx slot	29.41	29.25	29.56	PASS
GPRS 2 Tx slots	27.39	27.18	26.93	PASS
GPRS 3 Tx slots	25.78	25.52	25.22	PASS
GPRS 4 Tx slots	23.66	23.41	23.17	PASS
EDGE 1 Tx slot	24.73	24.71	24.78	PASS
EDGE 2 Tx slots	24.39	24.41	24.51	PASS
EDGE 3 Tx slots	22.37	22.23	22.36	PASS
EDGE 4 Tx slots	19.47	19.37	19.57	PASS



WCDMA 850		Average Power (dBm)			Verdict
TX Channel		4132	4175	4233	
Frequency (MHz)		826.4	835.0	846.6	
3GPP Rel 99	RMC 2.2Kbps	21.56	21.59	21.53	PASS

WCDMA 1900		Average Power (dBm)			Verdict
TX Channel		9262	9400	9538	
Frequency (MHz)		1852.4	1880	1907.6	
3GPP Rel 99	RMC 2.2Kbps	21.67	21.66	21.73	PASS

2.2. Peak to Average Ratio

2.2.1. Requirement

According to FCC 24.232(d) the peak-to-average ratio (PAR) of the transmission may not exceed 13 dB.

2.2.2. Test Description

Test Setup:

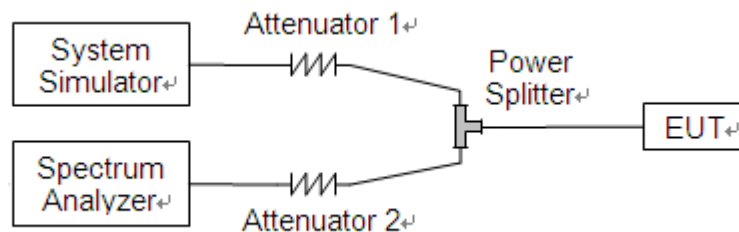

The EUT is coupled to the Spectrum Analyzer (SA) and the System Simulator (SS) with Attenuators through the Power Splitter; the RF load attached to the EUT antenna terminal is 50Ohm; the path loss as the factor is calibrated to correct the reading. The EUT is commanded by the SS to operate at the maximum output power i.e. Power Control Level (PCL) = 5 and Power Class = 4. A call is established between the EUT and the SS.

2.2.3. Test procedure

1 .For GSM/EGPRS operating mode:

- a. Set RBW=1MHz, VBW=3MHz, peak detector in spectrum analyzer.
- b. Set EUT in maximum output power, and triggered the bust signal.
- c. Measured respectively the peak level and mean level, and the deviation was recorded as Peak to Average radio.

2. For UMTS operating mode:

- a. Set the CCDF (Complementary Cumulative Distribution Function) option in spectrum analyzer.
- b. The highest RF powers were measured and recorded the maximum PAPR level associated with a probability of 0.1%.



2.2.4. Test Result

The lowest, middle and highest channels are selected to perform testing to verify the conducted RF output peak power of the Module.

A. Test Verdict:

Band	Channel	Frequency (MHz)	Peak to Average ratio		Limit	Verdict
			dB	Refer to Plot	dB	
GPRS 1900MHz	512	1850.2	0.05	Plot A1 to A3	13	PASS
	661	1880.0	0.03			PASS
	810	1909.8	0.04			PASS
EGPRS 1900MHz	512	1850.2	0.01	Plot B1 to B3	13	PASS
	661	1880.0	0.01			PASS
	810	1909.8	0.01			PASS
WCDMA 1900MHz	9262	1852.4	2.55	Plot C1 to C3	13	PASS
	9400	1880.0	3.01			PASS
	9538	1907.6	3.09			PASS



B. Test Plots:



(Plot A1, GSM 1900 MHz, Channel = 512)



(Plot A2, GSM 1900 MHz, Channel = 661)



(Plot A3, GSM 1900MHz, Channel = 810)



(Plot B1, EGPRS 1900 MHz, Channel = 512)



(Plot B2, EGPRS 1900 MHz, Channel = 661)



(Plot B3, EGPRS 1900MHz, Channel = 810)



(Plot C1, WCDMA 1900MHz, Channel = 9262)



(Plot C2, WCDMA 1900MHz, Channel = 9400)



(Plot C3, WCDMA 1900MHz, Channel = 9538)

2.3.99% Occupied Bandwidth

2.3.1. Requirement

According to FCC section 2.1049 and FCC § 22.917 & 24.238, the occupied bandwidth is the frequency bandwidth such that, below its lower and above its upper frequency limits, the mean powers radiated are each equal to 0.5 percent of the total mean power radiated by a given emission. Occupied bandwidth is also known as the 99% emission bandwidth.

2.3.2. Test Description

Test Setup:

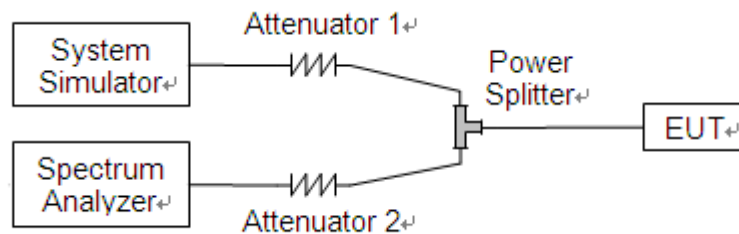

The EUT is coupled to the Spectrum Analyzer (SA) and the System Simulator (SS) with Attenuators through the Power Splitter; the RF load attached to the EUT antenna terminal is 50Ohm; the path loss as the factor is calibrated to correct the reading. The EUT is commanded by the SS to operate at the maximum output power i.e. Power Control Level (PCL) = 5 and Power Class = 4. A call is established between the EUT and the SS.



2.3.3. Test Result

The lowest, middle and highest channels are selected to perform testing to record the 99% occupied bandwidth.

GSM Test Verdict:

Band	Channel	Frequency (MHz)	99% Occupied Bandwidth (kHz)	26dB Bandwidth (kHz)
GPRS 850MHz	128	824.2	242.82	317.2
	190	836.6	250.13	328.6
	251	848.8	243.38	323.9
GPRS 1900MHz	512	1850.2	240.68	307.8
	661	1880.0	255.49	327.1
	810	1909.8	246.37	323.6
EGPRS 850MHz	128	824.2	247.17	318.8
	190	836.6	249.90	320.4
	251	848.8	246.37	317.7
EGPRS 1900MHz	512	1850.2	243.32	319.3
	661	1880.0	248.14	316.9
	810	1909.8	242.66	317.9



Test Plots:

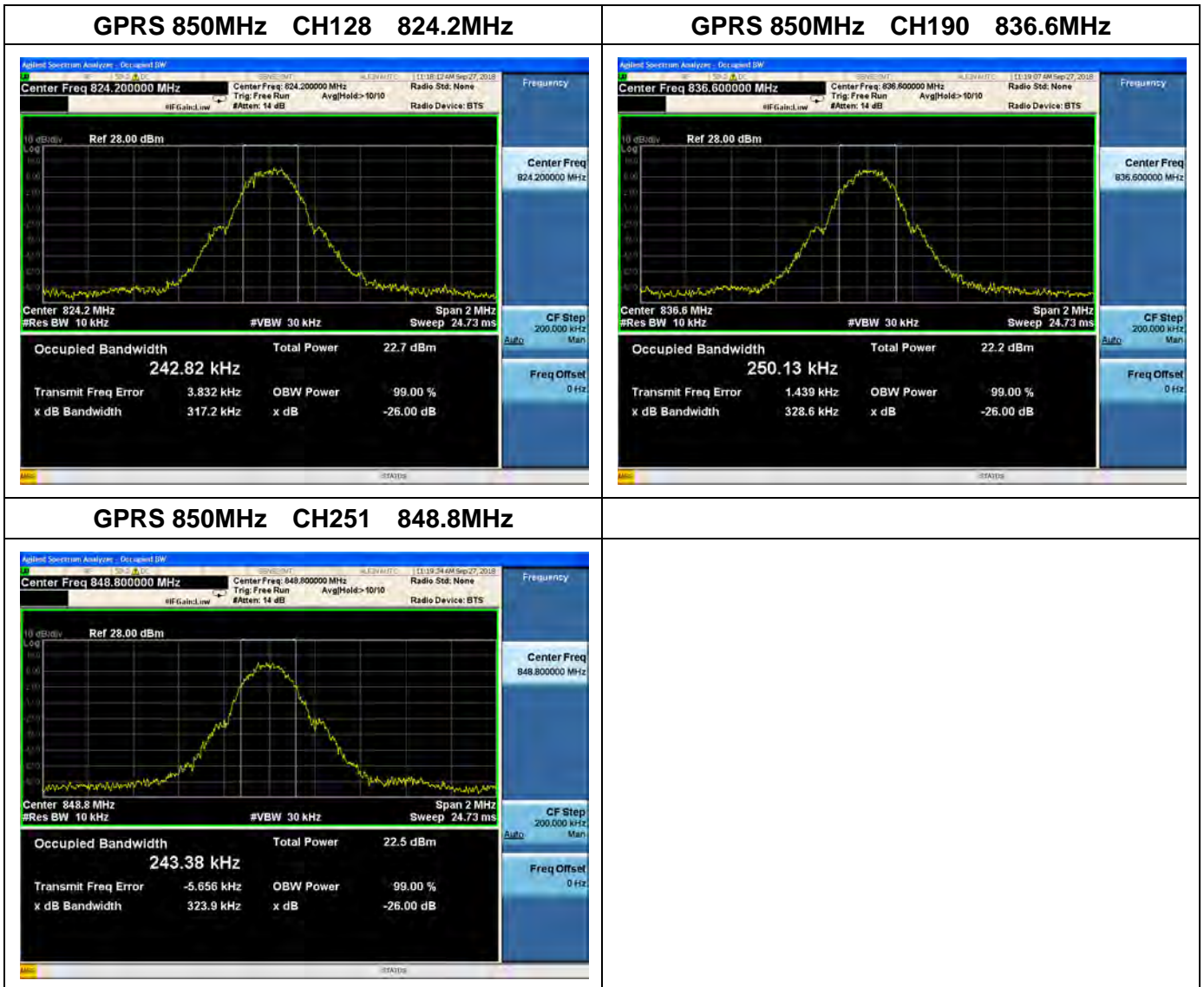

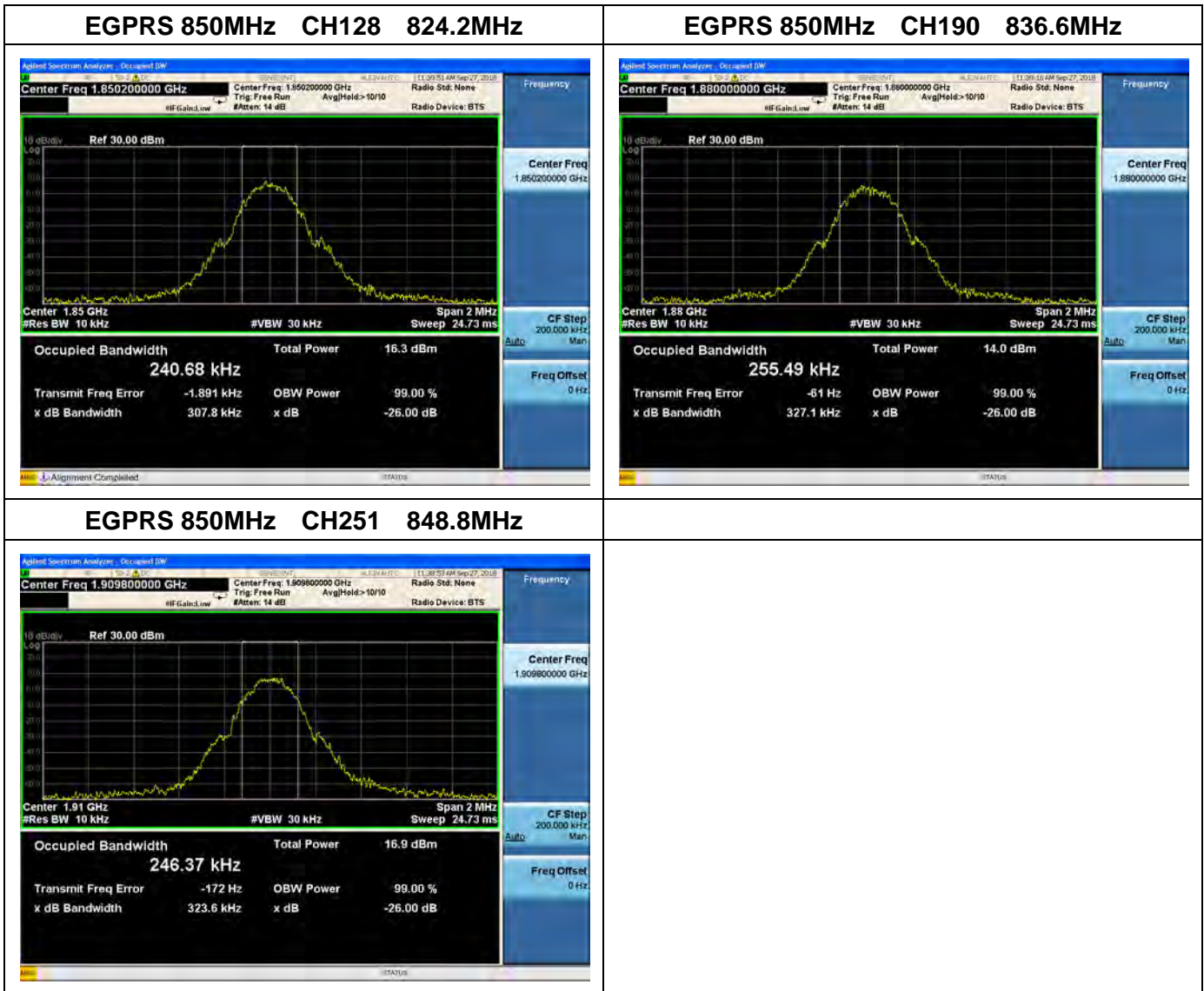



WCDMA Test Verdict:

Band	Channel	Frequency (MHz)	99% Occupied Bandwidth (MHz)	26dB Bandwidth (MHz)
WCDMA 850MHz	4132	826.4	4.100	4.634
	4175	835.0	4.111	4.662
	4233	846.6	4.105	4.668
WCDMA 1900MHz	9262	1852.4	4.088	4.676
	9400	1880.0	4.123	4.652
	9538	1907.6	4.100	4.635

Test Plots:

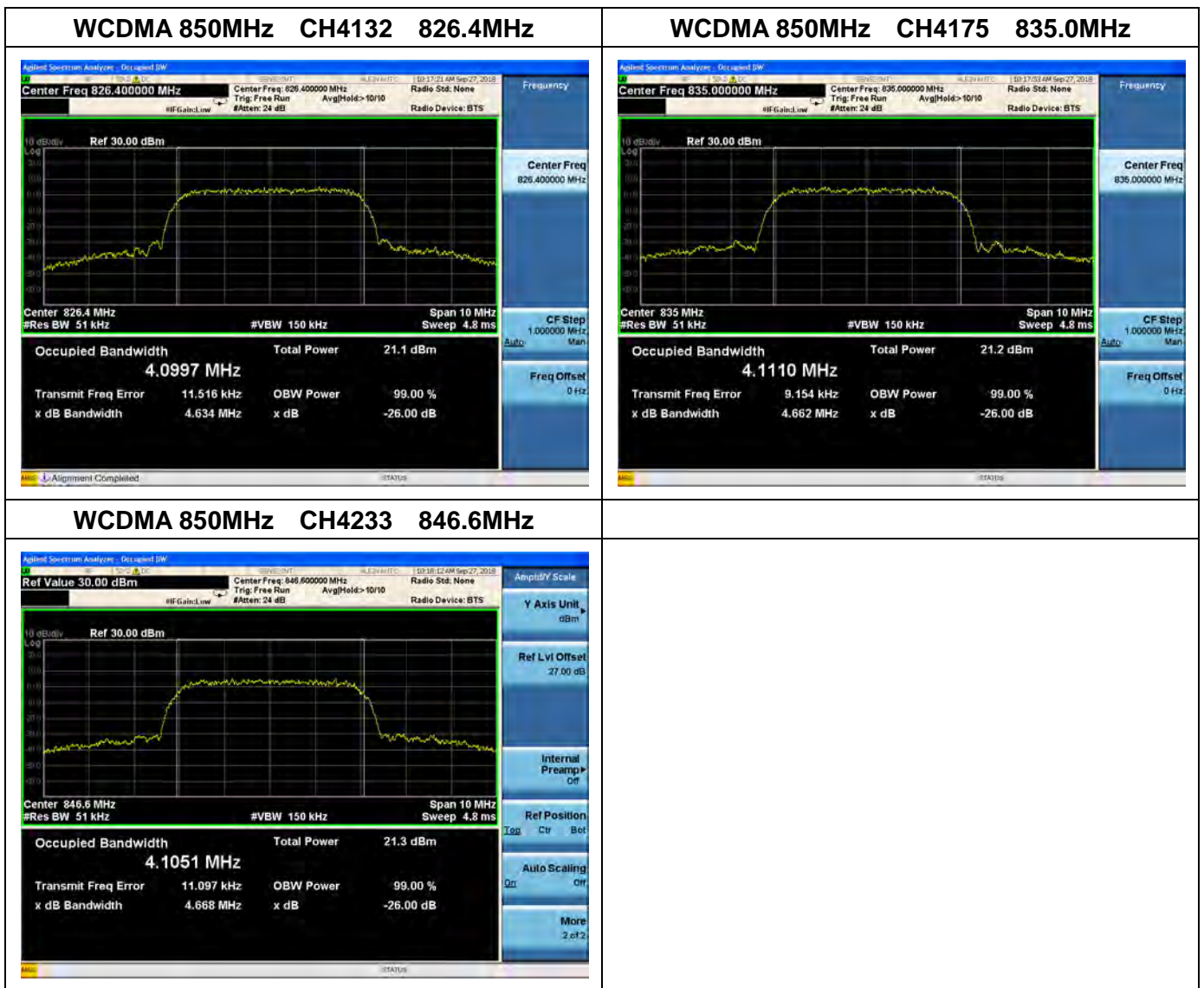

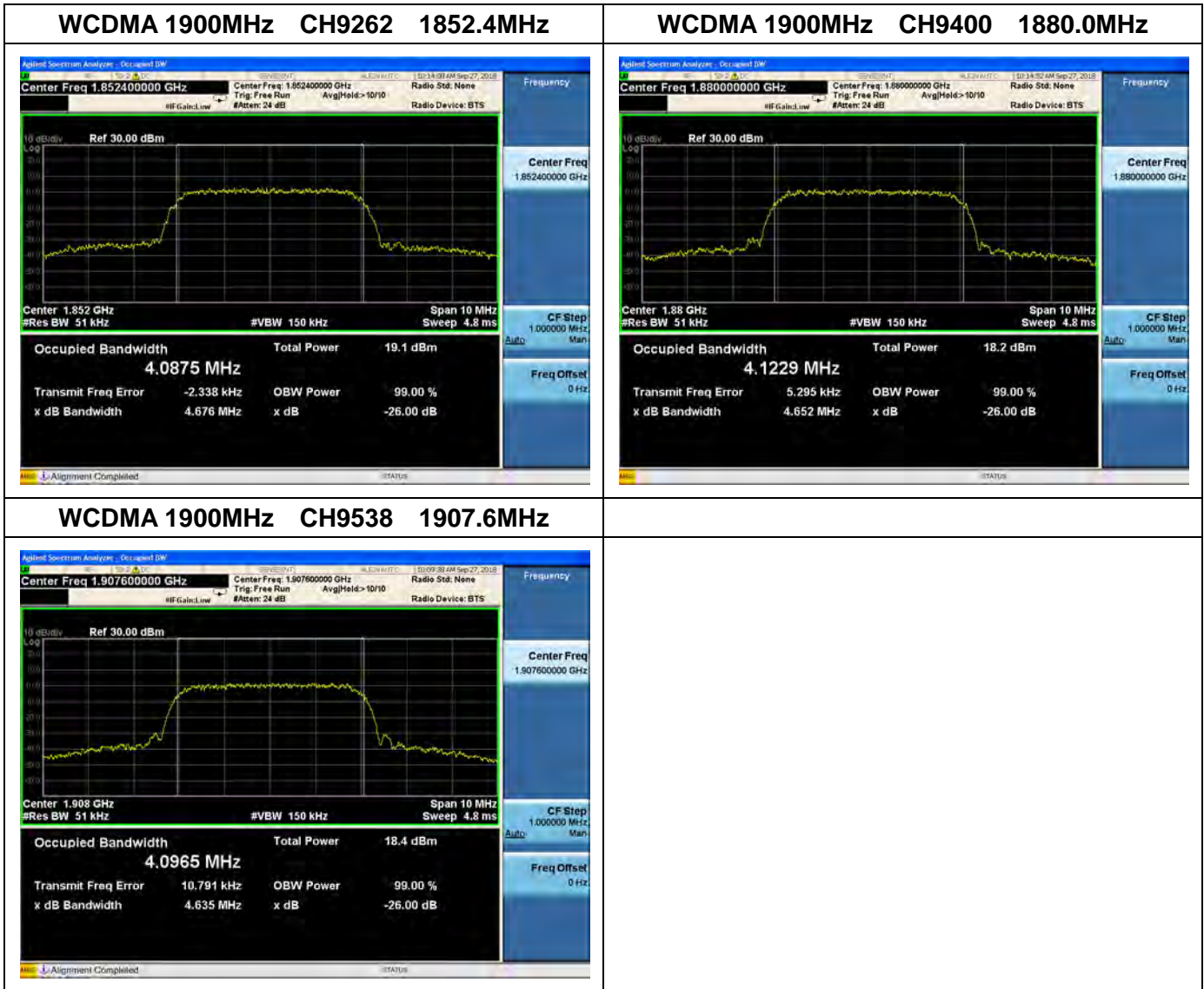

2.4. Frequency Stability

2.4.1. Requirement

The frequency stability shall be sufficient to ensure that the fundamental emission stays within the authorized frequency block.

According to FCC section 2.1055, the test conditions are:

- (a) The temperature is varied from -30°C to $+50^{\circ}\text{C}$ at intervals of not more than 10°C .
- (b) For hand carried battery powered equipment, the primary supply voltage is reduced to the battery operating end point which shall be specified by the manufacture. The supply voltage shall be measured at the input to the cable normally provided with the equipment, or at the power supply terminals if cables are not normally provided.

2.4.2. Test Description

Test Setup:

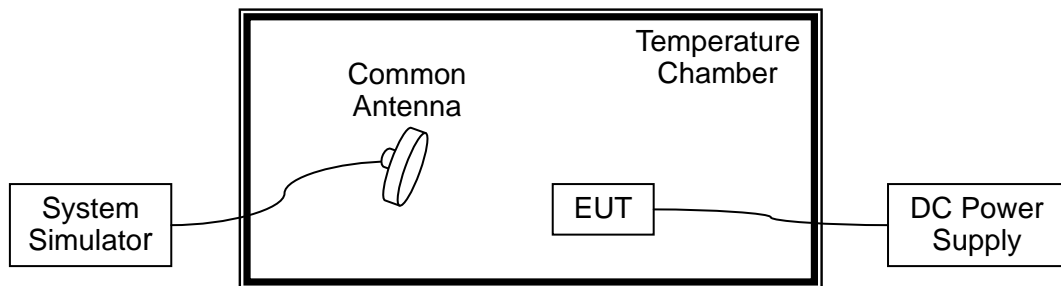

The EUT, which is powered by the DC Power Supply directly, is located in the Temperature Chamber. The EUT is commanded by the System Simulator (SS) to operate at the maximum output power i.e. Power Control Level (PCL) = 5 and Power Class = 4. A call is established between the EUT and the SS via a Common Antenna.



2.4.3. Test Result

The nominal, highest and lowest extreme voltages are separately 5.0V, 5.2V and 4.8V which is specified by the applicant; the normal temperature here used is 25°C.

GPRS 850MHz, Channel 190, Frequency 836.6MHz					
Limit =±2.5ppm					
Voltage (%)	Power (VDC)	Temp (°C)	Fre. Dev. (Hz)	Deviation (ppm)	Result
100	5.0	+20(Ref)	51	0.061	PASS
100		-30	-28	-0.033	
100		-20	-37	-0.044	
100		-10	-43	-0.051	
100		0	-68	-0.081	
100		+10	33	0.039	
100		+20	29	0.035	
100		+30	27	0.032	
100		+40	26	0.031	
100		+50	51	0.061	
115	5.2	+20	-37	-0.044	
85	4.8	+20	-43	-0.051	

GPRS 1900MHz, Channel 661, Frequency 1880.0MHz					
Limit = Within Authorized Band					
Voltage (%)	Power (VDC)	Temp (°C)	Fre. Dev. (Hz)	Deviation (ppm)	Result
100	5.0	+20(Ref)	51	0.027	PASS
100		-30	34	0.018	
100		-20	-73	-0.039	
100		-10	32	0.017	
100		0	41	0.022	
100		+10	-79	-0.042	
100		+20	-77	-0.041	
100		+30	-83	-0.044	
100		+40	31	0.016	
100		+50	35	0.019	
115	5.2	+20	-84	-0.045	
85	4.8	+20	35	0.019	



EGPRS 850MHz, Channel 190, Frequency 836.6MHz					
Limit =±2.5ppm					
Voltage (%)	Power (VDC)	Temp (°C)	Fre. Dev. (Hz)	Deviation (ppm)	Result
100	5.0	+20(Ref)	19	0.023	PASS
100		-30	-75	-0.090	
100		-20	-37	-0.044	
100		-10	-43	-0.051	
100		0	-68	-0.081	
100		+10	33	0.039	
100		+20	29	0.035	
100		+30	27	0.032	
100		+40	26	0.031	
100		+50	51	0.061	
115	5.2	+20	-23	-0.027	
85	4.8	+20	-43	-0.051	

EGPRS 1900MHz, Channel 661, Frequency 1880.0MHz					
Limit =Within Authorized Band					
Voltage (%)	Power (VDC)	Temp (°C)	Fre. Dev. (Hz)	Deviation (ppm)	Result
100	5.0	+20(Ref)	47	0.025	PASS
100		-30	61	0.032	
100		-20	-65	-0.035	
100		-10	31	0.016	
100		0	41	0.022	
100		+10	-79	-0.042	
100		+20	-77	-0.041	
100		+30	-83	-0.044	
100		+40	31	0.016	
100		+50	35	0.019	
115	5.2	+20	-84	-0.045	
85	4.8	+20	27	0.014	



WCDMA 850MHz, Channel 4175, Frequency 835.0MHz					
Limit =±2.5ppm					
Voltage (%)	Power (VDC)	Temp (°C)	Fre. Dev. (Hz)	Deviation (ppm)	Result
100	5.0	+20(Ref)	18	0.022	PASS
100		-30	-81	-0.097	
100		-20	-77	-0.092	
100		-10	-43	-0.051	
100		0	-68	-0.081	
100		+10	33	0.040	
100		+20	29	0.035	
100		+30	27	0.032	
100		+40	26	0.031	
100		+50	51	0.061	
115	5.2	+20	-33	-0.040	
85	4.8	+20	-53	-0.063	

WCDMA 1900MHz, Channel 9400, Frequency 1880.0MHz					
Limit =Within Authorized Band					
Voltage (%)	Power (VDC)	Temp (°C)	Fre. Dev. (Hz)	Deviation (ppm)	Result
100	5.0	+20(Ref)	61	0.032	PASS
100		-30	55	0.029	
100		-20	-58	-0.031	
100		-10	29	0.015	
100		0	-79	-0.042	
100		+10	-79	-0.042	
100		+20	26	0.014	
100		+30	19	0.010	
100		+40	17	0.009	
100		+50	35	0.019	
115	5.2	+20	-87	-0.046	
85	4.8	+20	23	0.012	

2.5. Conducted Out of Band Emissions

2.5.1. Requirement

According to FCC section 22.917(a) and FCC section 24.238(a) the power of any emission outside of the authorized operating frequency ranges must be attenuated below the transmitting power (P) by a factor of at least $43+10*\log(P)$ dB. This calculated to be -13dBm.

2.5.2. Test Description

Test Setup:

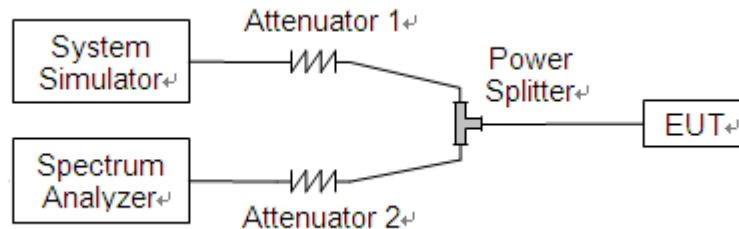

The EUT is coupled to the Spectrum Analyzer (SA) and the System Simulator (SS) with Attenuators through the Power Splitter; the RF load attached to the EUT antenna terminal is 50Ohm; the path loss as the factor is calibrated to correct the reading. The EUT is commanded by the SS to operate at the maximum output power i.e. Power Control Level (PCL) = 5 and Power Class = 4. A call is established between the EUT and the SS.

2.5.3. Test Result

The measurement frequency range is from 30MHz to the 10th harmonic of the fundamental frequency. The lowest, middle and highest channels are tested to verify the out of band emissions.



GPRS 850MHz CH128 824.2MHz

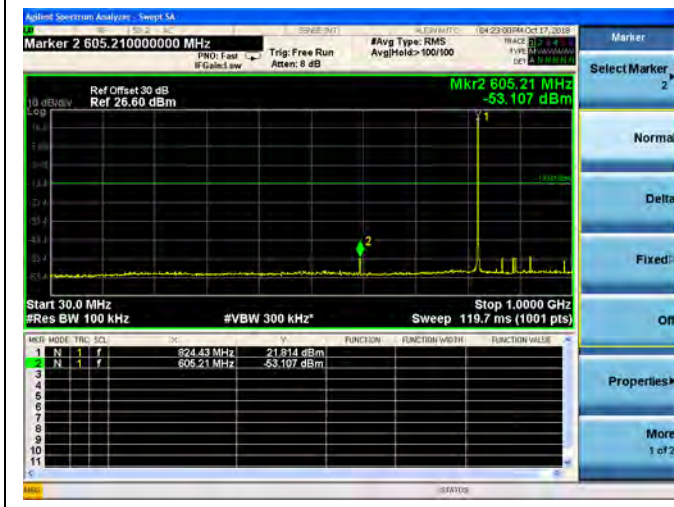

GPRS 850MHz CH190 836.6MHz

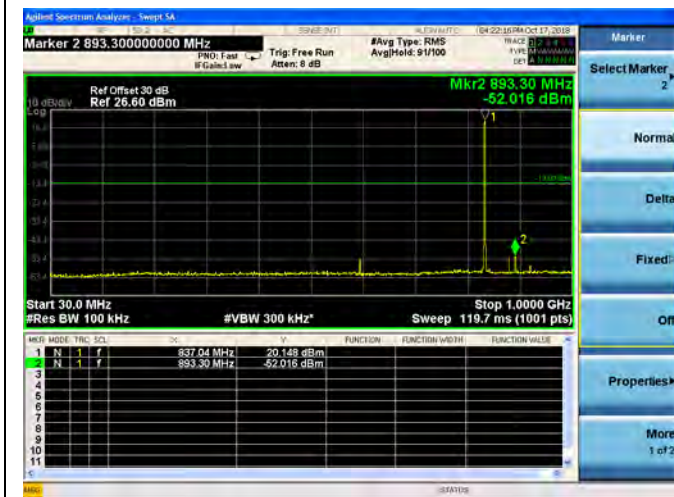

GPRS 850MHz CH251 848.8MHz

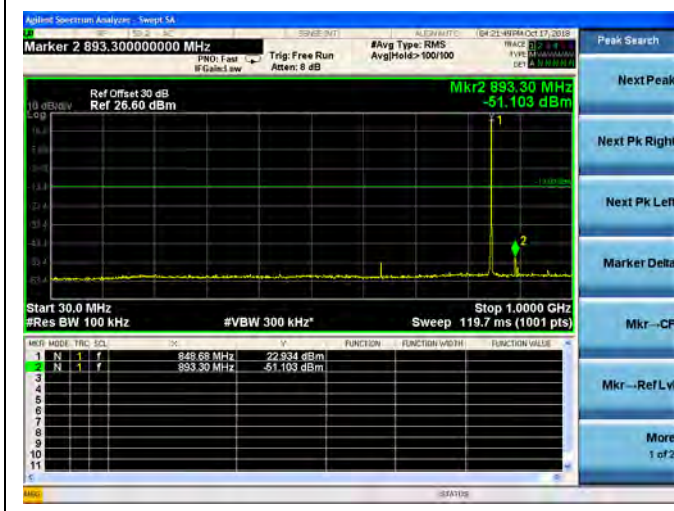



GPRS 1900MHz CH521 1850.2MHz

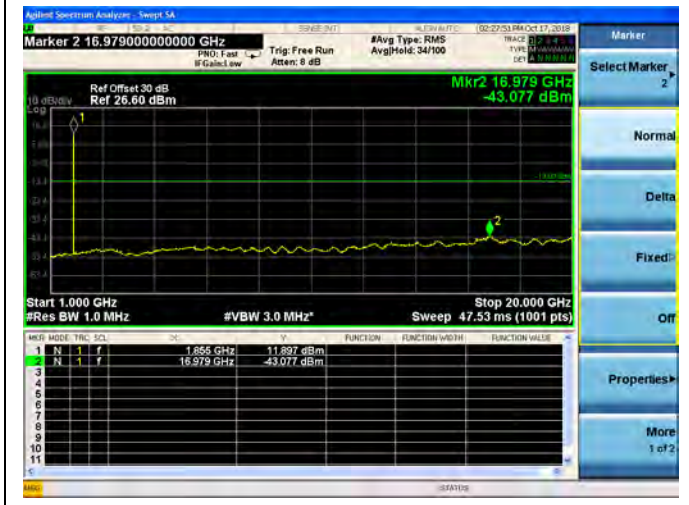

GPRS 1900MHz CH661 1880.0MHz

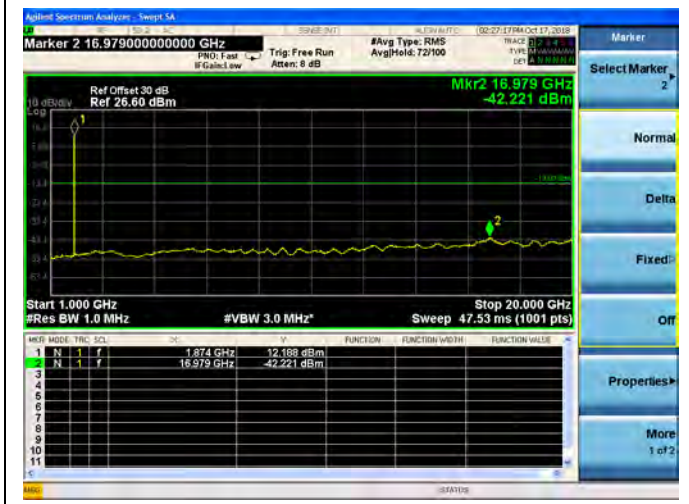

GPRS 1900MHz CH810 1909.8MHz

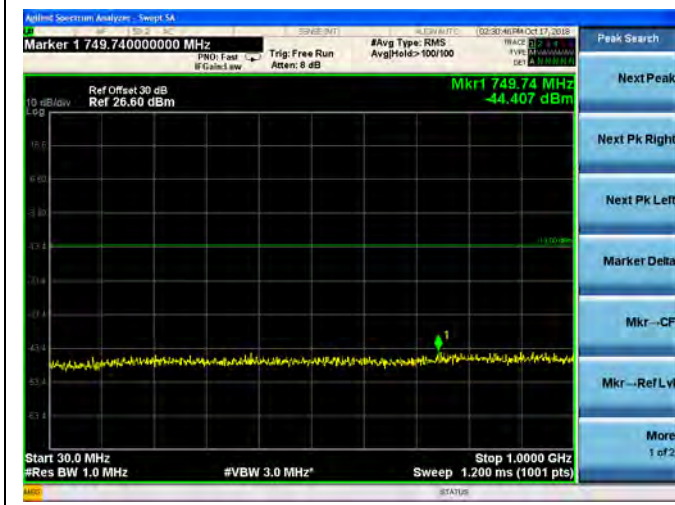



EGPRS 850MHz CH128 824.2MHz

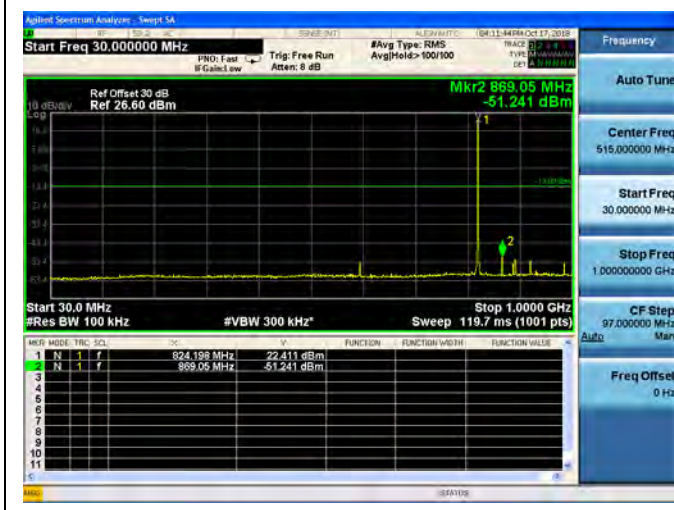

EGPRS 850MHz CH190 836.6MHz

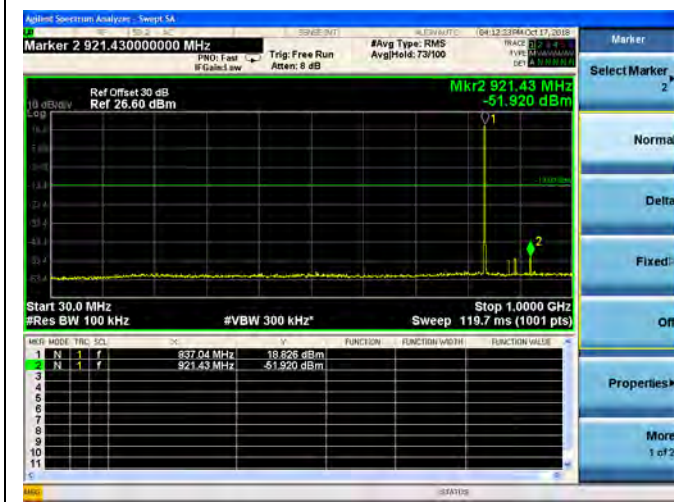

EGPRS 850MHz CH251 848.8MHz

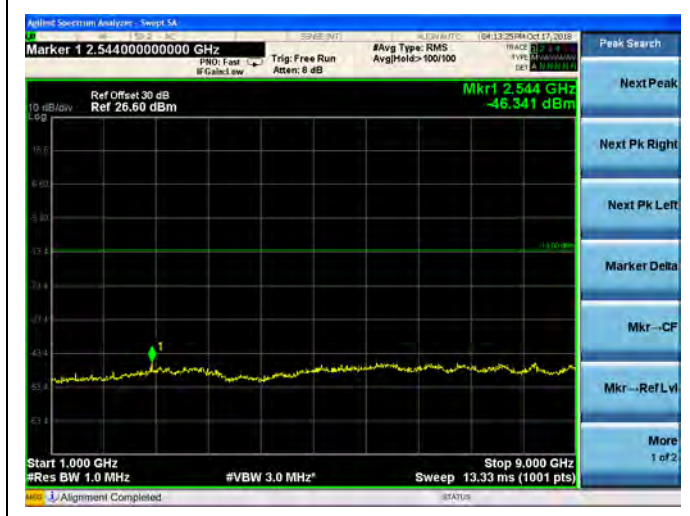
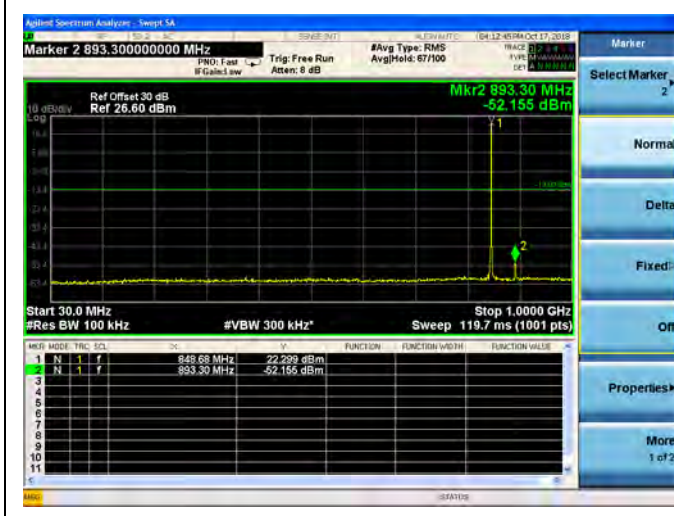



EGPRS 1900MHz CH521 1850.2MHz



EGPRS 1900MHz CH661 1880.0MHz



EGPRS 1900MHz CH810 1909.8MHz

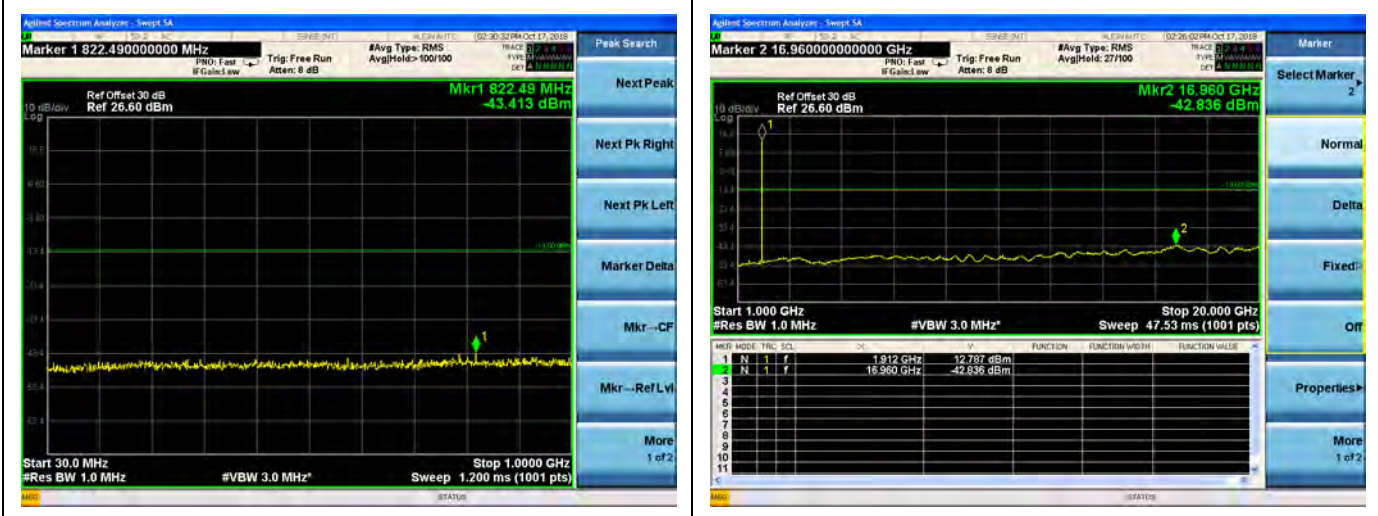



WCDMA 850MHz CH4132 826.4MHz

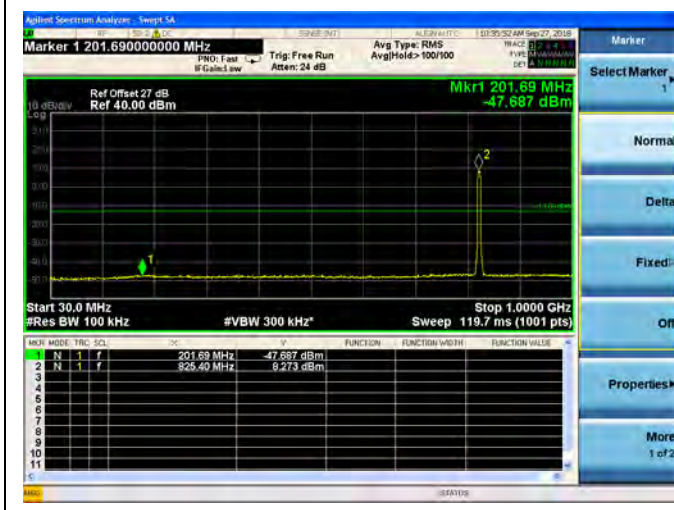

WCDMA 850MHz CH4175 835.0MHz

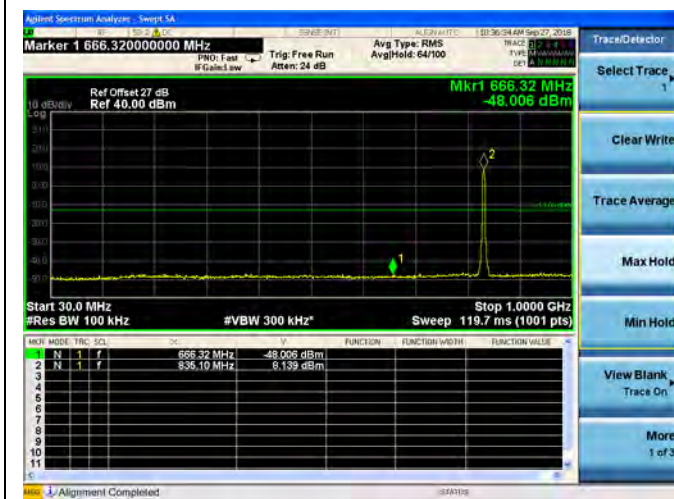

WCDMA 850MHz CH4233 846.6MHz

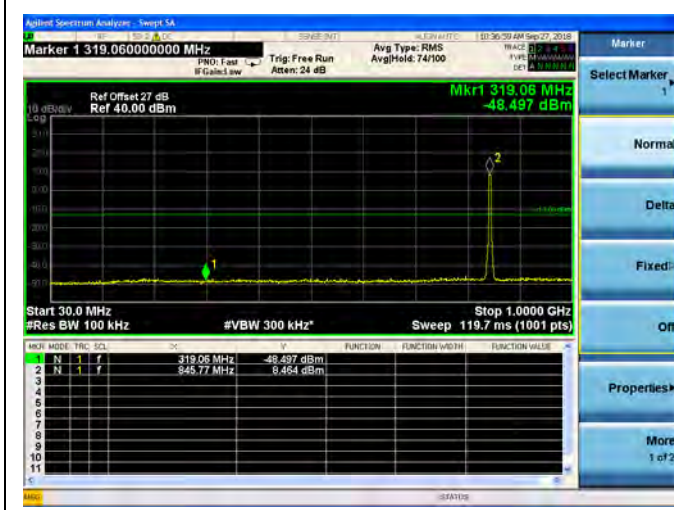



WCDMA 1900MHz CH9262 1852.4MHz

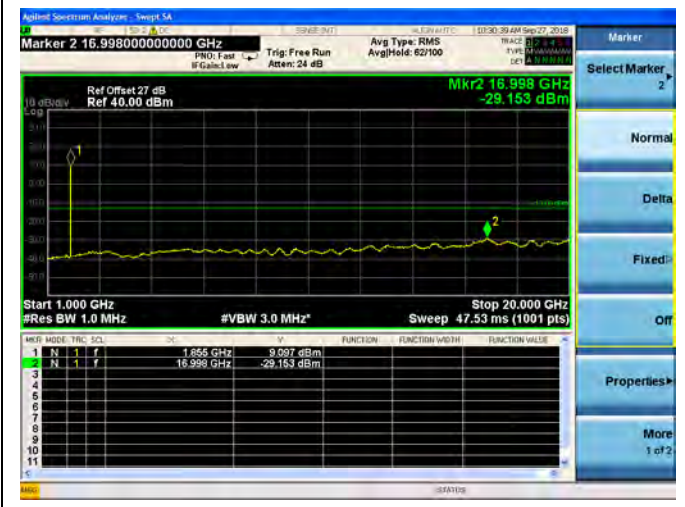

WCDMA 1900MHz CH9400 1880.0MHz

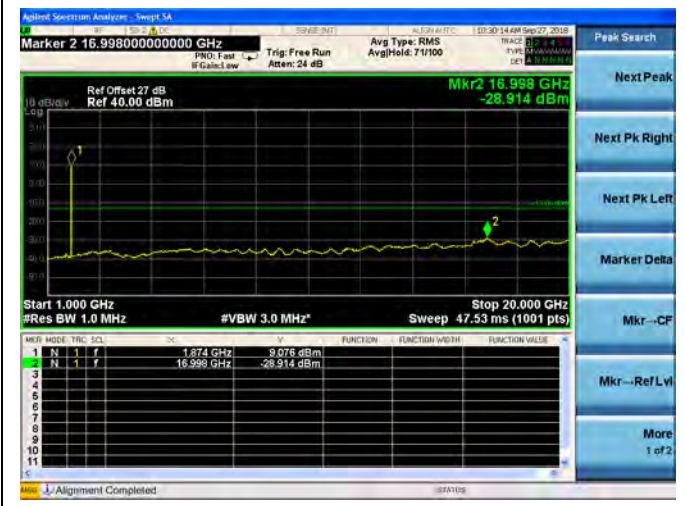

WCDMA 1900MHz CH9538 1907.6MHz

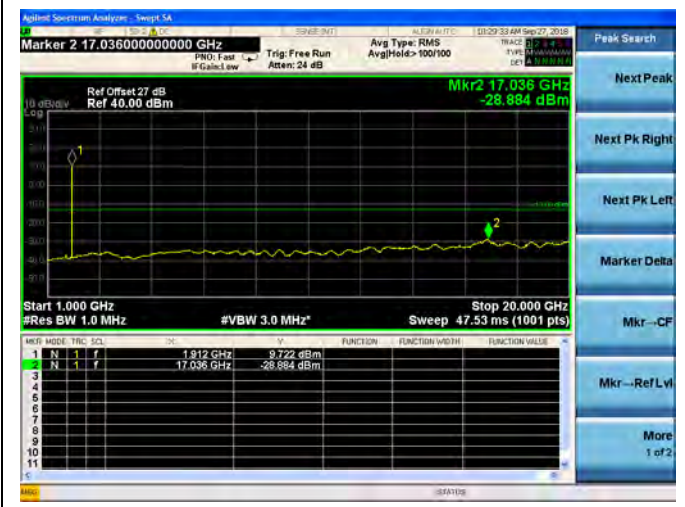

2.6. Band Edge

2.6.1. Requirement

According to FCC section 22.917(b) and FCC section 24.238(b) in the 1MHz bands immediately outside and adjacent to the frequency block a resolution bandwidth of at least one percent of the emission bandwidth (26dB emission bandwidth) of the fundamental emission of the transmitter may be employed.

2.6.2. Test Description

Test Setup:

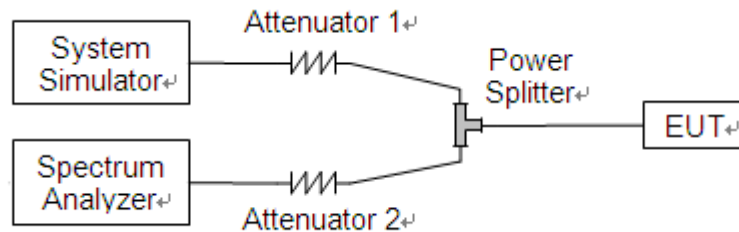

The EUT is coupled to the Spectrum Analyzer (SA) and the System Simulator (SS) with Attenuators through the Power Splitter; the RF load attached to the EUT antenna terminal is 50Ohm; the path loss as the factor is calibrated to correct the reading. The EUT is commanded by the SS to operate at the maximum output power i.e. Power Control Level (PCL) = 5 and Power Class = 4. A call is established between the EUT and the SS.

2.6.3. Test Result

The lowest and highest channels are tested to verify the band edge emissions.



GPRS 850MHz CH128 824.2MHz

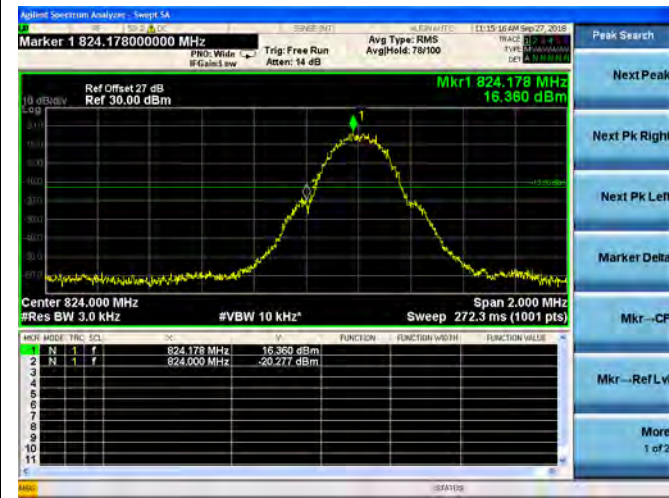

GPRS 850MHz CH251 848.8MHz

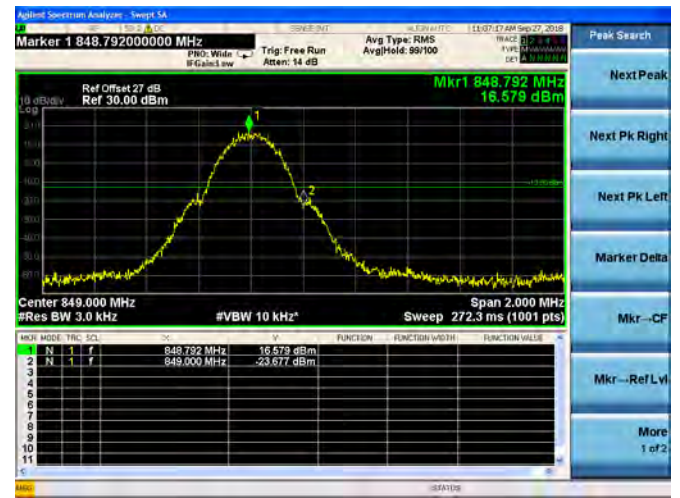

GPRS 1900MHz CH521 1850.2MHz

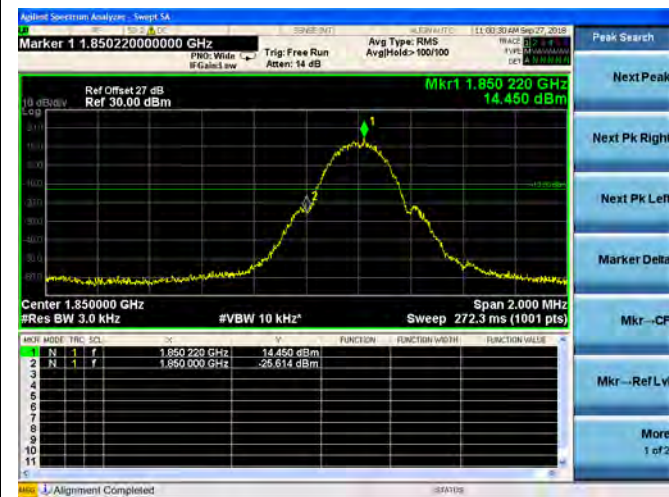

GPRS 1900MHz CH810 1909.8MHz

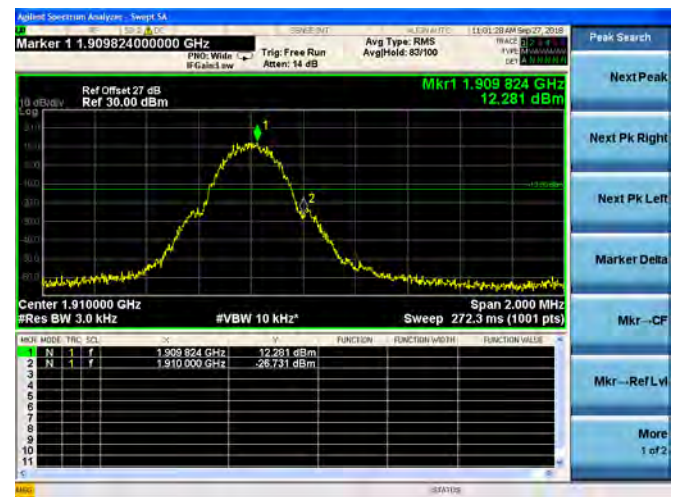



EGPRS 850MHz CH128 824.2MHz

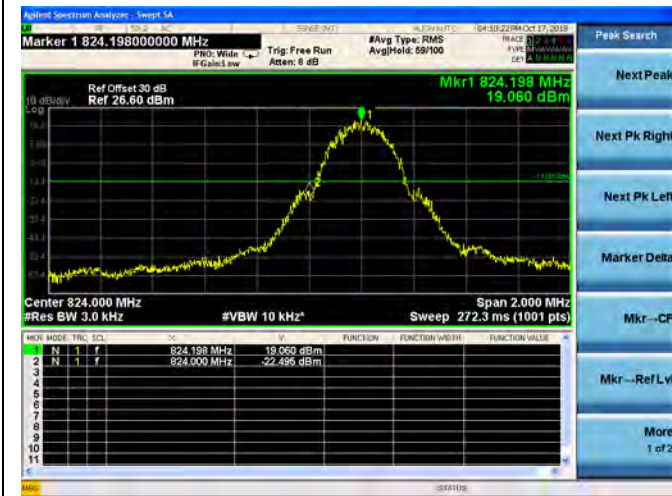

EGPRS 850MHz CH251 848.8MHz

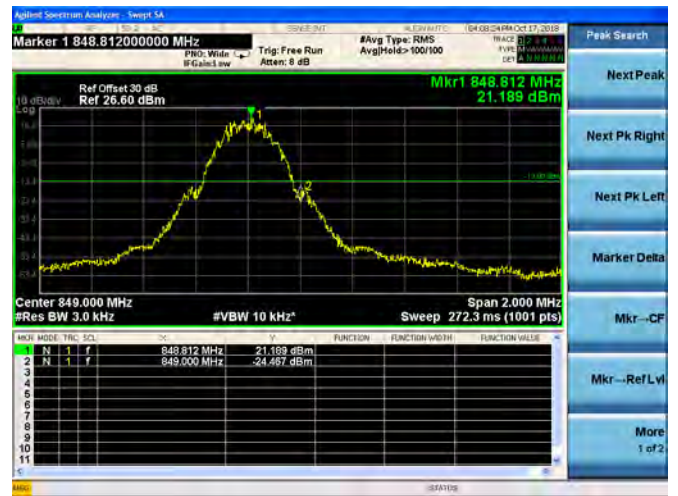

EGPRS 1900MHz CH521 1850.2MHz

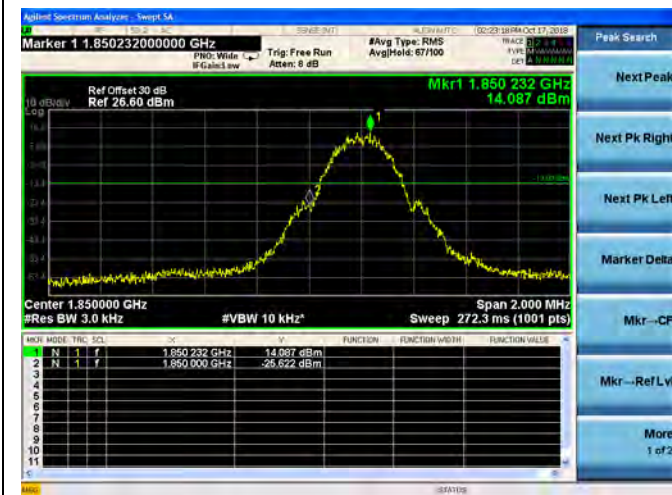

EGPRS 1900MHz CH810 1909.8MHz

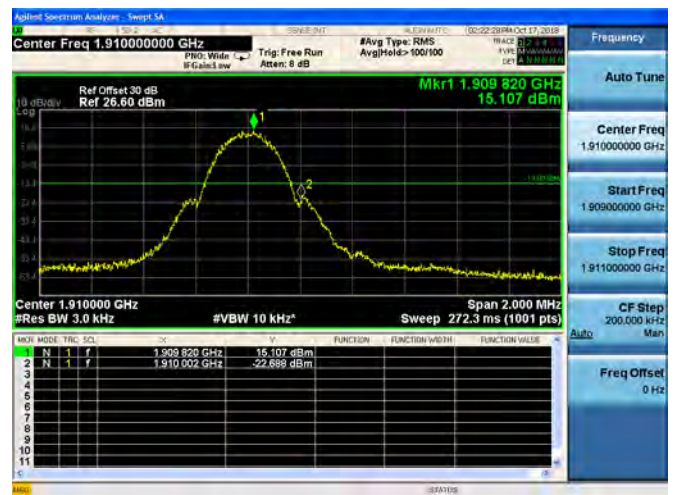

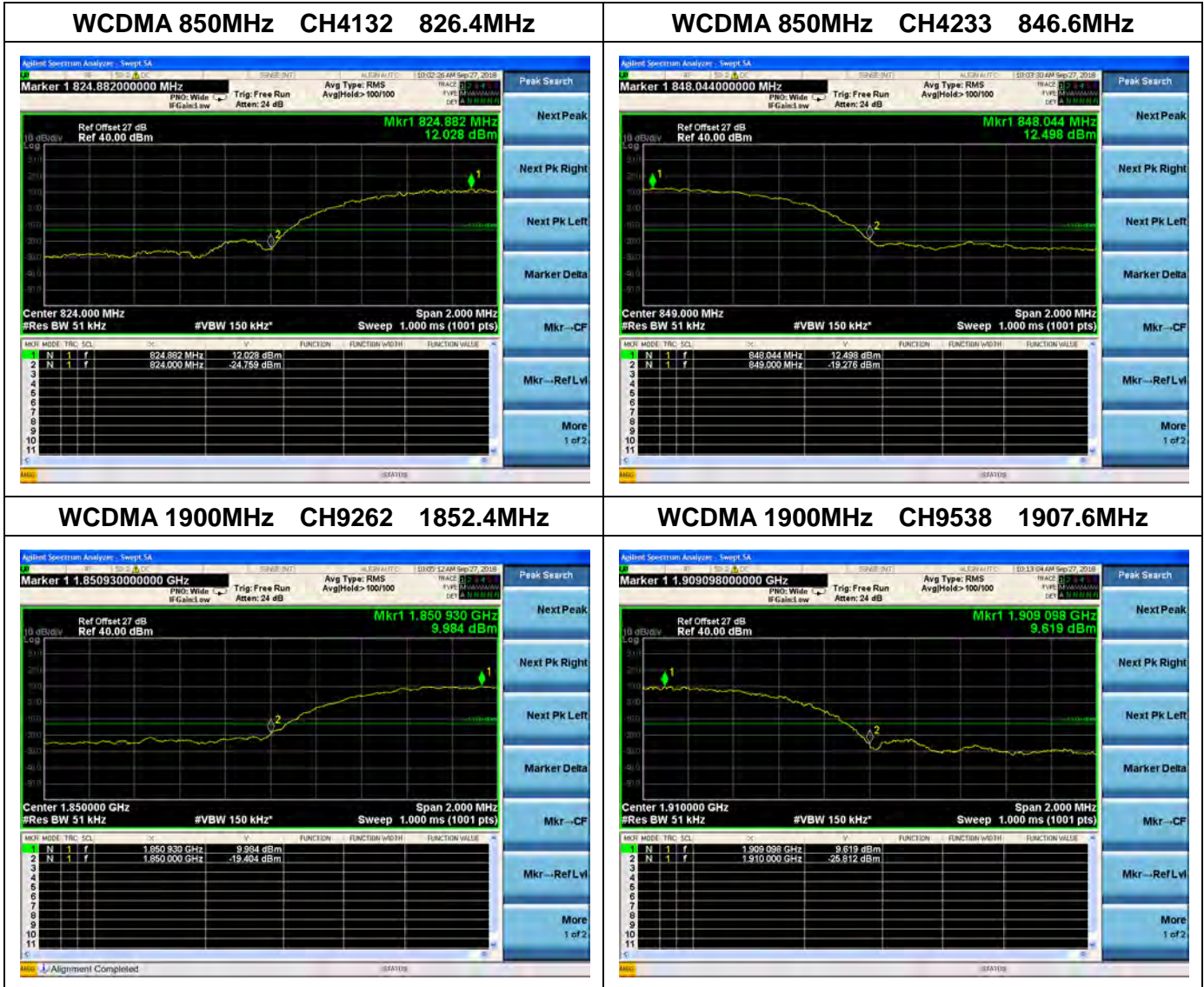

2.7. Transmitter Radiated Power (EIRP/ERP)

2.7.1. Requirement

According to FCC section 22.913, the Effective Radiated Power (ERP) of mobile transmitters and auxiliary test transmitters must not exceed 7Watts.

According to FCC section 24.232, the broadband PCS mobile station is limited to 2 Watts e.i.r.p. peak power.

According to FCC section 27.50, mobile, and portable (hand-held) stations is limited to 1 Watts e.i.r.p. peak power.

2.7.2. Test Description

Test Setup:

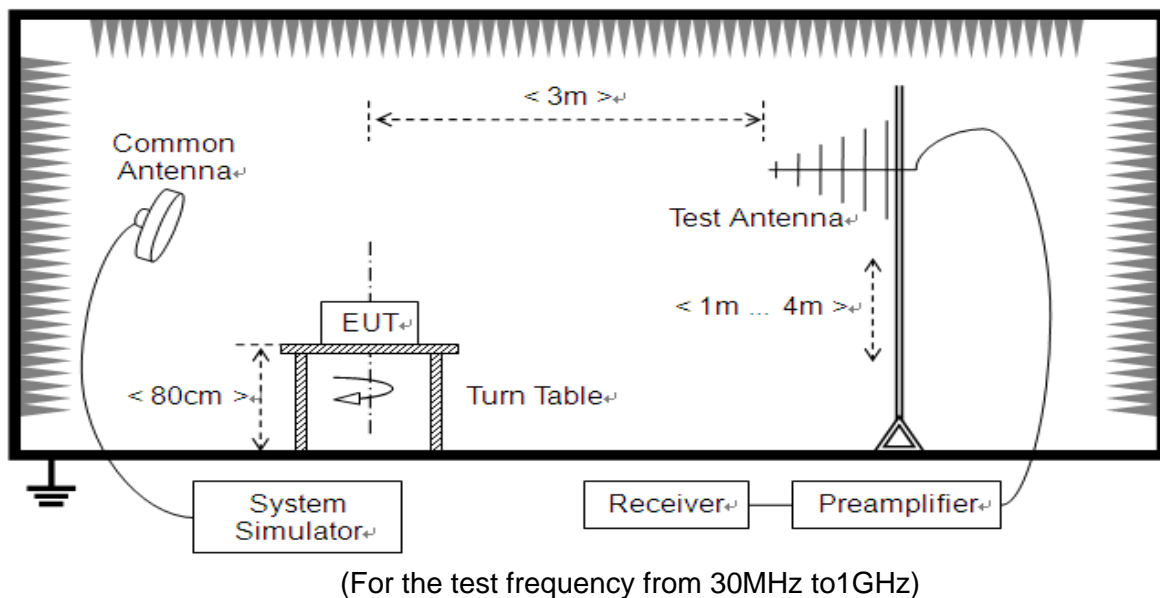

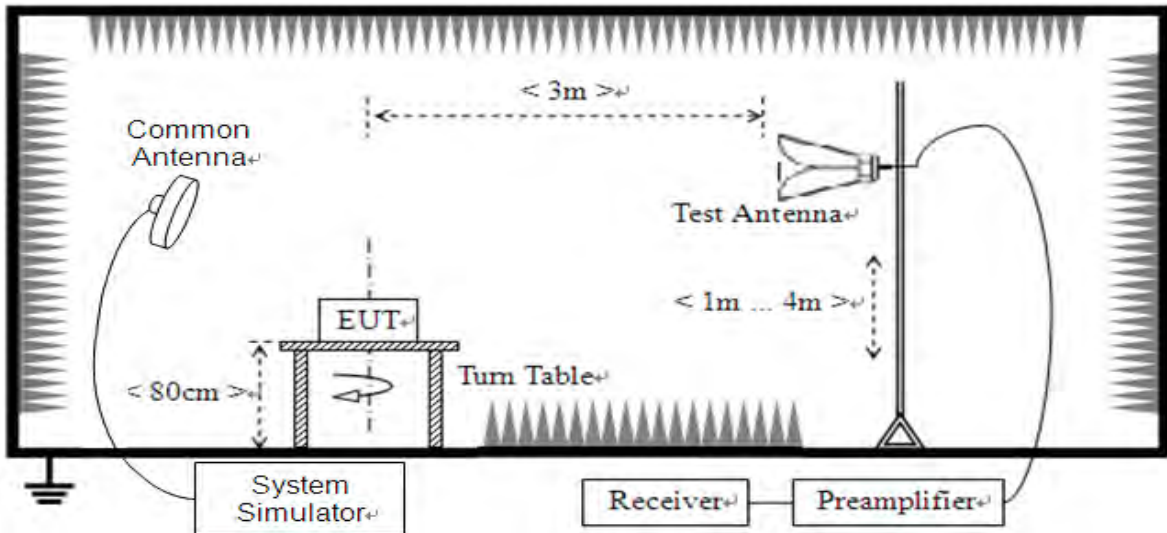

(For the test frequency above 1GHz)

The EUTs are located in a 3m Full-Anechoic Chamber; the cable loss, air loss and so on of the site as factors are pre-calibrated using the "Substitution" method, and calculated to correct the reading. A call is established between the EUT and the SS via a Common Antenna. The EUT is commanded by the SS to operate at the maximum and minimum output power (i.e. GSM850MHz band Power Control Level (PCL) = 5/19 and Power Class = 4, GSM1900MHz band Power Control Level (PCL) = 0/15 and Power Class = 1), and only the test result of the maximum output power was recorded. Please refer to section 2.1.3 of this report.

- Step size (dB): 3dB

The Test Antenna is a Bi-Log one (used for 30MHz to 1GHz) or a Horn one (used for above 3GHz), it's located at the same height as the EUT. The Filters consist of Notch Filters and High Pass Filter.



2.7.3. Test Result

The Turn Table is actuated to turn from 0° to 360°, and both horizontal and vertical polarizations of the Test Antenna are used to find the maximum radiated power. The lowest, middle and highest channels are tested.

The substitution corrections are obtained as described below:

$$A_{SUBST} = P_{SUBST_TX} - P_{SUBST_RX} - L_{SUBST_CABLES} + G_{SUBST_TX_ANT}$$

$$A_{TOT} = L_{CABLES} + A_{SUBST}$$

Where A_{SUBST} is the final substitution correction including receive antenna gain.

P_{SUBST_TX} is signal generator level,

P_{SUBST_RX} is receiver level,

L_{SUBST_CABLES} is cable losses including TX cable,

$G_{SUBST_TX_ANT}$ is substitution antenna gain.

A_{TOT} is total correction factor including cable loss and substitution correction

During the test, the data of A_{TOT} was added in the Test Spectrum Analyze, so Spectrum Analyze reading is the final values which contain the data of A_{TOT} .

GSM Test verdict:

Band	Channel	Frequency (MHz)	PCL	Measured ERP			Limit		Verdict
				dBm	W	Refer to Plot	dBm	W	
GPRS 850MHz	128	824.20	5	33.85	2.427	Plot A	38.5	7	PASS
	190	836.60	5	32.75	1.884				PASS
	251	848.80	5	32.28	1.690				PASS
EGPRS 850MHz	128	824.20	5	27.69	0.587	Plot B ^{Note 1}	38.5	7	PASS
	190	836.60	5	30.11	1.026				PASS
	251	848.80	5	29.96	0.991				PASS
GPRS 1900MHz	512	1850.2	5	21.14	0.130	Plot C	33	2	PASS
	661	1880.0	5	25.38	0.345				PASS
	810	1909.8	5	27.92	0.619				PASS
EGPRS 1900MHz	512	1850.2	0	21.32	0.136	Plot D ^{Note 1}	33	2	PASS
	661	1880.0	0	25.51	0.356				PASS
	810	1909.8	0	28.10	0.646				PASS

Note 1: For the GPRS and EGPRS model, all the slots were tested and just the worst data were recorded in this report.

Note 2: Both horizontal and vertical polarizations of the test antenna are evaluated respectively, only the worst data (horizontal) were recorded in this report.



Test Plots:

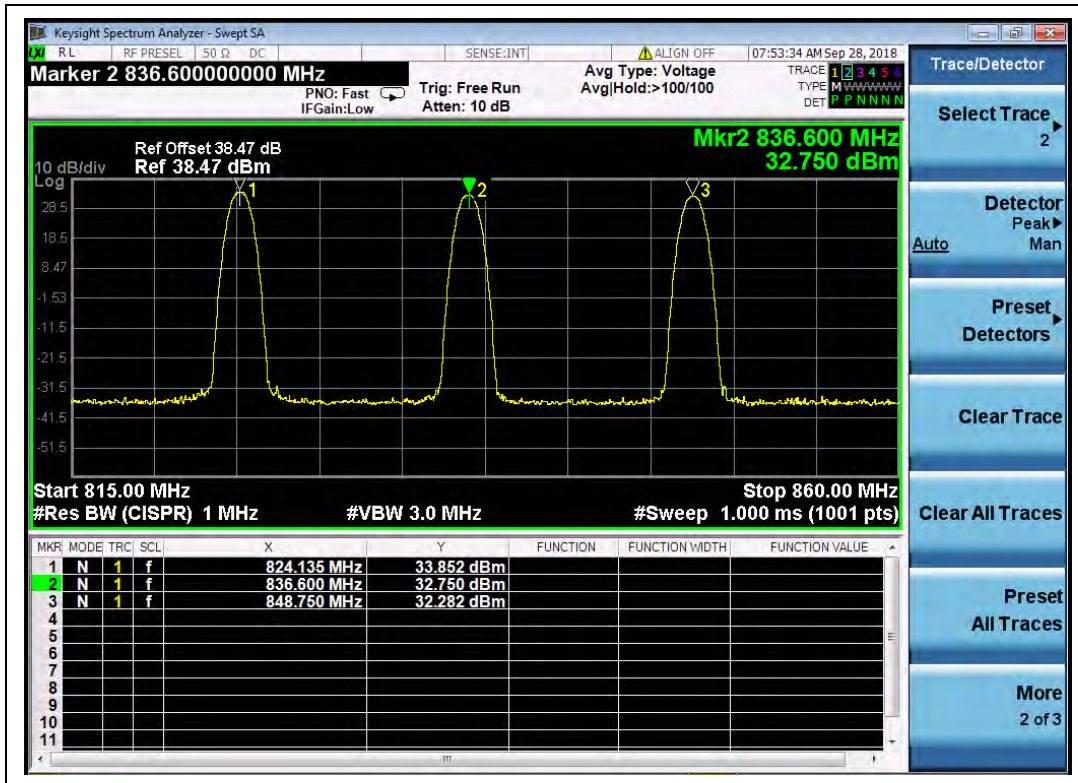

(Plot A, GPRS 850MHz, Channel = 128, 190, 251)

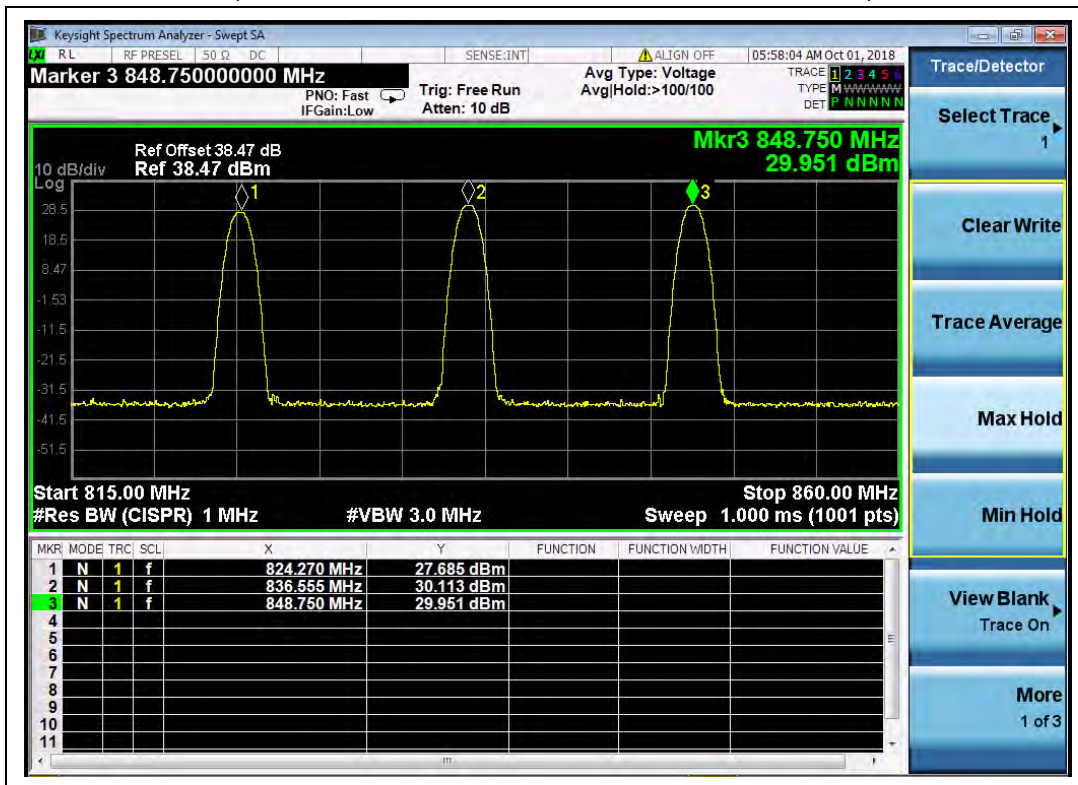

(Plot B, EGPRS 850MHz, Channel = 128, 190, 251)

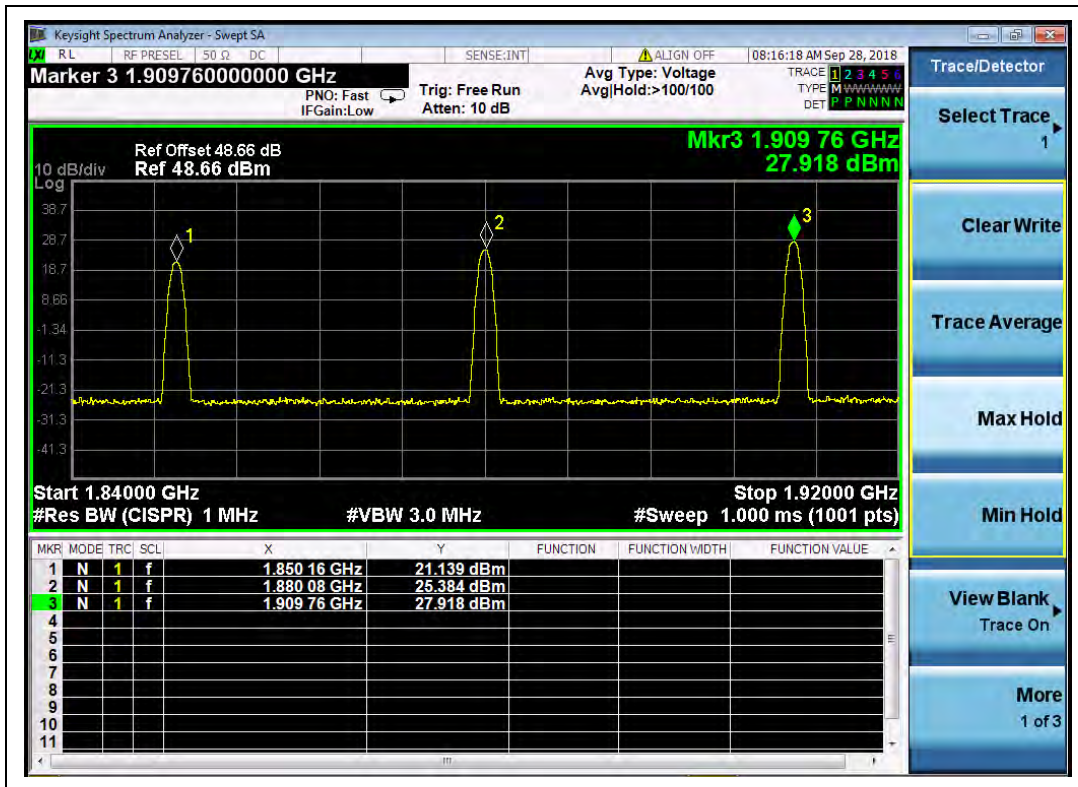

(Plot C, GPRS 1900MHz, Channel = 512, 661, 810)

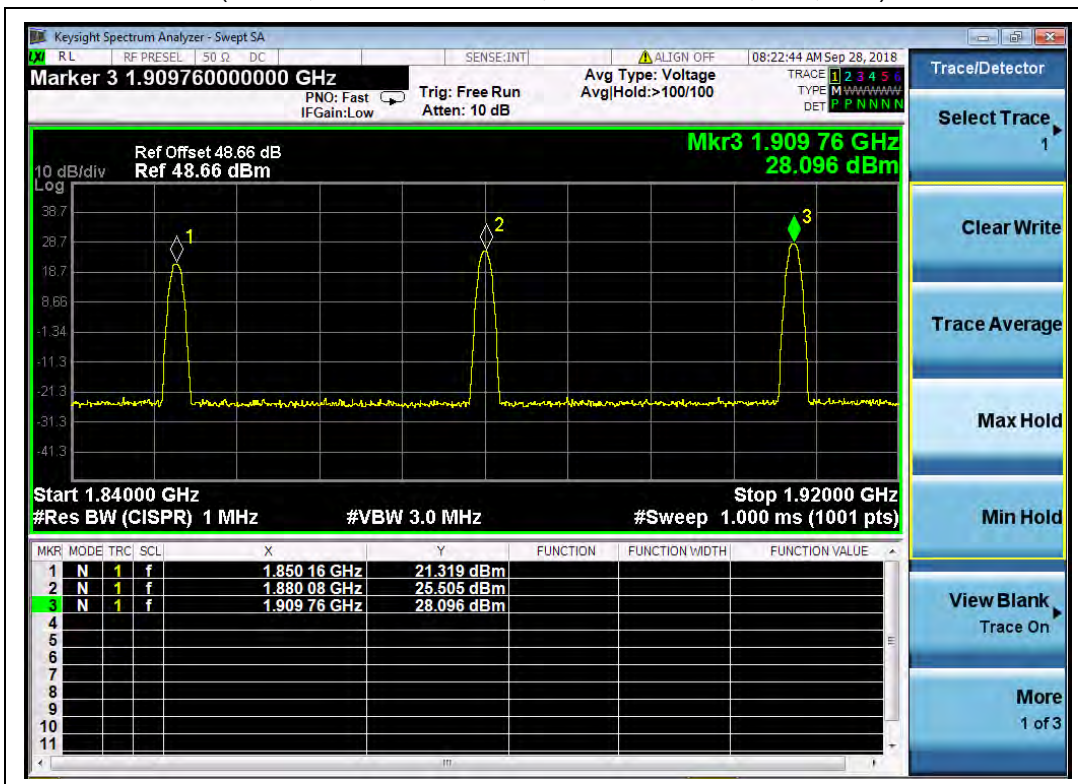

(Plot D, EGPRS 1900MHz, Channel = 512, 661, 810)



WCDMA Test verdict:

Band	Channel	Frequency (MHz)	Measured ERP			Limit		Verdict
			dBm	W	Refer to Plot	dBm	W	
WCDMA 850MHz	4132	826.4	23.09	0.204	Plot E	38.5	7	PASS
	4175	835.0	22.87	0.194				PASS
	4233	846.6	21.14	0.130				PASS
WCDMA 1900MHz	9262	1852.4	18.92	0.078	Plot F	33	2	PASS
	9400	1880.0	19.76	0.095				PASS
	9538	1907.6	22.09	0.162				PASS

Note 1: Both horizontal and vertical polarizations of the test antenna are evaluated respectively, only the worst data (horizontal) were recorded in this report.

Test Plot

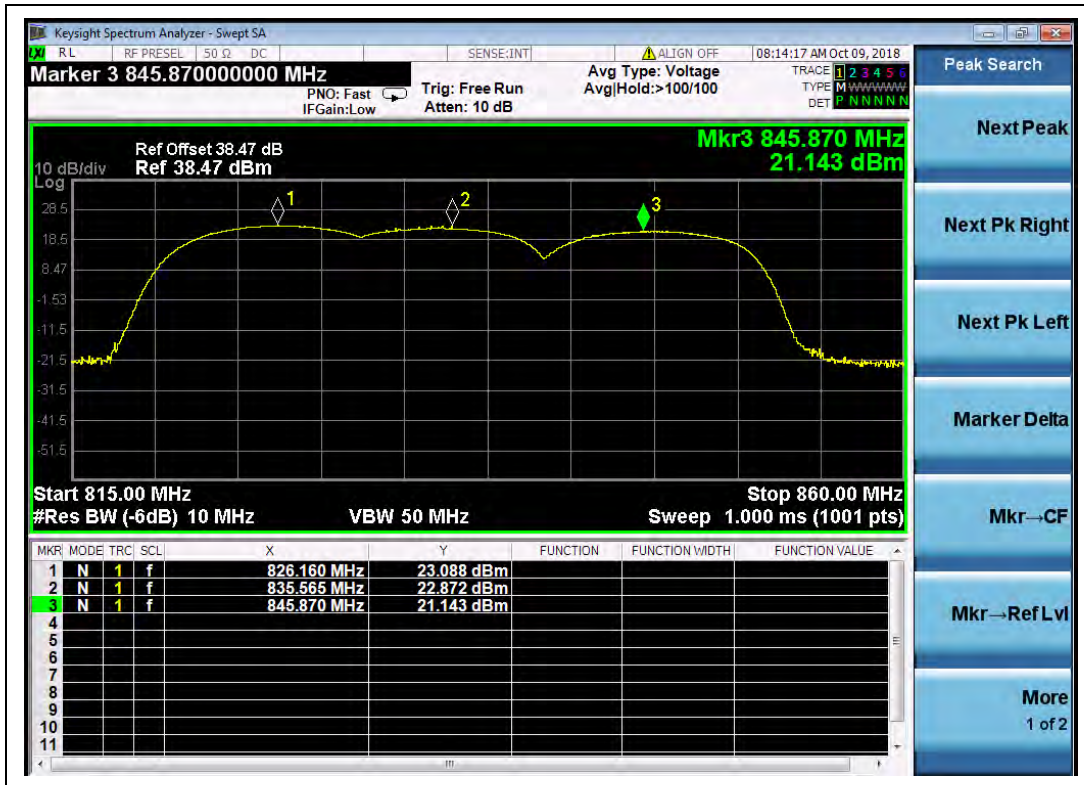

(Plot E, WCDMA 850 MHz, Channel = 4132, 4175, 4233)

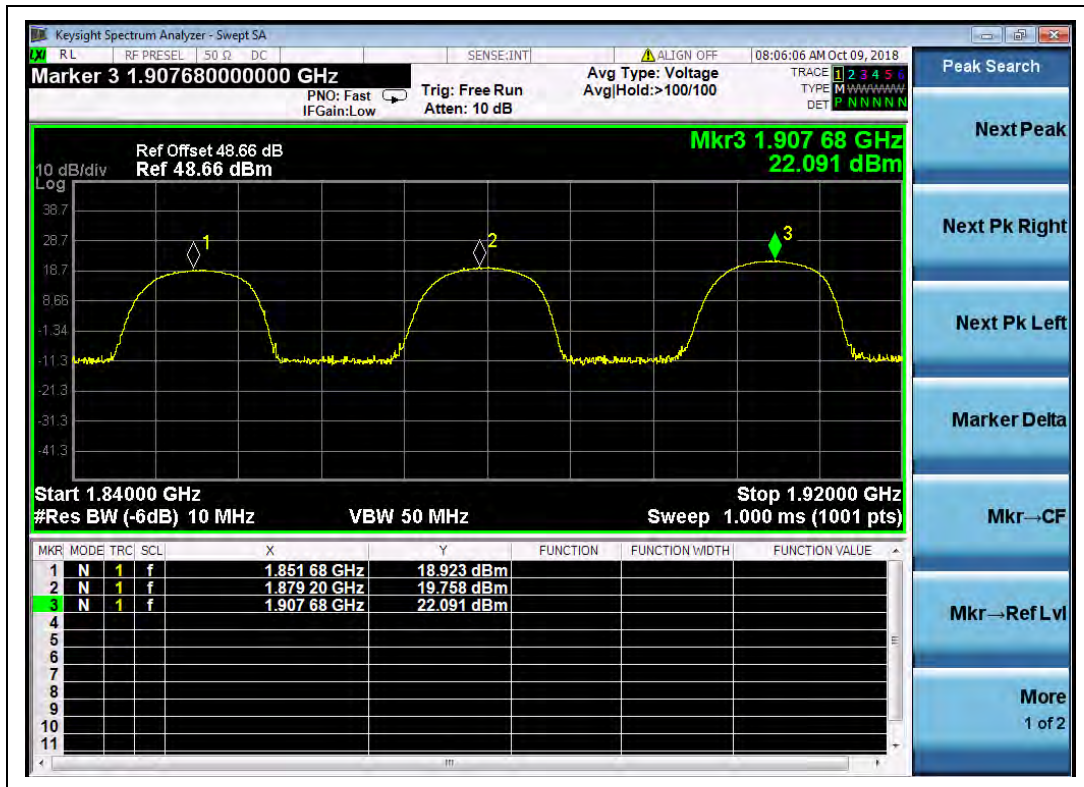

(Plot F, WCDMA 1900 MHz, Channel = 9262, 9400, 9538)

2.8. Radiated Out of Band Emissions

2.8.1. Requirement

The power of any emission outside of the authorized operating frequency ranges must be attenuated below the transmitting power (P) by a factor of at least $43+10*\log(P)$ dB. This calculated to be -13dBm.

2.8.2. Test Description

Test Setup:

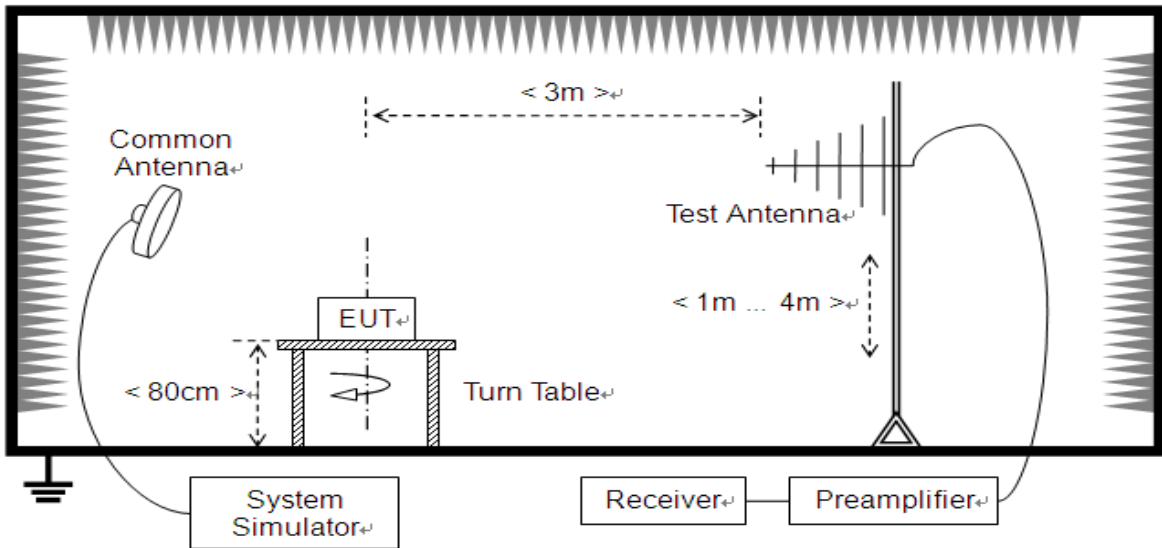

(For the test frequency from 30MHz to 1GHz)

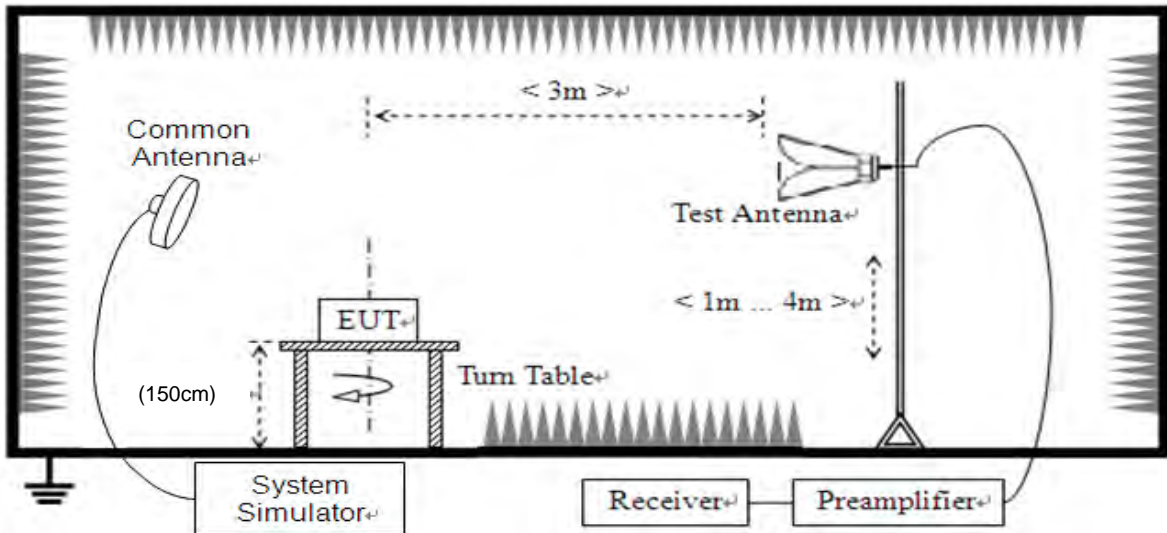

(For the test frequency above 1GHz)

The EUT is located in a 3m Full-Anechoic Chamber, the cable loss, air loss and so on of the site as factors are pre-calibrated using the "Substitution" method, and calculated to correct the reading. A call is established between the EUT and the SS via a Common Antenna. The EUT is commanded by the SS to operate at the maximum and minimum output power (i.e. GSM850MHz band Power Control Level (PCL) = 5/19 and Power Class = 4, GSM1900MHz band Power Control Level (PCL) = 0/15 and Power Class = 1), and only the test result of the maximum output power was recorded. Please refer to section 2.1.3 of this report.

- Step size (dB): 3dB

The Test Antenna is a Bi-Log one (used for 30MHz to 1GHz) and a Horn one (used for above 3 GHz), it's located at the same height as the EUT. The Filters consists of Notch Filters and High Pass Filter.

Note: when doing measurements above 1GHz, the EUT has been within the 3dB cone width of the horn antenna during horizontal antenna.

2.8.3. Test Result

The measurement frequency range is from 30MHz to the 10th harmonic of the fundamental frequency. The Turn Table is actuated to turn from 0° to 360°, and both horizontal and vertical polarizations of the Test Antenna are used to find the maximum radiated power. The lowest, middle and highest channels are tested to verify the out of band emissions. The power of the EUT transmitting frequency should be ignored.

Note 1: All test mode and condition mentioned were considered and evaluated respectively by performing full test, only the worst data were recorded and reported.

Note 2: All Spurious Emission tests were performed in X, Y, Z axis direction. And only the worst axis test condition was recorded in this test report.



A. Test Verdict:

Band	Channel	Frequency (MHz)	Measured Max. Spurious Emission (dBm)		Refer to Plot	Limit (dBm)	Verdict
			Test Antenna Horizontal	Test Antenna Vertical			
GPRS 850MHz	128	824.2	< -25	< -25	Plot A1/A2	-13	PASS
	190	836.6	< -25	< -25	Plot A3/A4		PASS
	251	848.8	< -25	< -25	Plot A5/A6		PASS
GPRS 1900MHz	512	1850.2	< -25	< -25	Plot B1/B2	-13	PASS
	661	1880.0	< -25	< -25	Plot B3/B4		PASS
	810	1909.8	< -25	< -25	Plot B5/B6		PASS
EGPRS 850MHz	128	824.2	< -25	< -25	Plot C1/C2	-13	PASS
	190	836.6	< -25	< -25	Plot C3/C4		PASS
	251	848.8	< -25	< -25	Plot C5/C6		PASS
EGPRS 1900MHz	512	1850.2	< -25	< -25	Plot D1/D2	-13	PASS
	661	1880.0	< -25	< -25	Plot D3/D4		PASS
	810	1909.8	< -25	< -25	Plot D5/D6		PASS
WCDMA 850MHz	4132	826.4	< -25	< -25	Plot E1/E2	-13	PASS
	4175	835.0	< -25	< -25	Plot E3/E4		PASS
	4233	846.6	< -25	< -25	Plot E5/E6		PASS
WCDMA 1900MHz	9262	1852.4	< -25	< -25	Plot F1/G2	-13	PASS
	9400	1880.0	< -25	< -25	Plot F3/G4		PASS
	9538	1907.6	< -25	< -25	Plot F5/G6		PASS

B. Test Plots

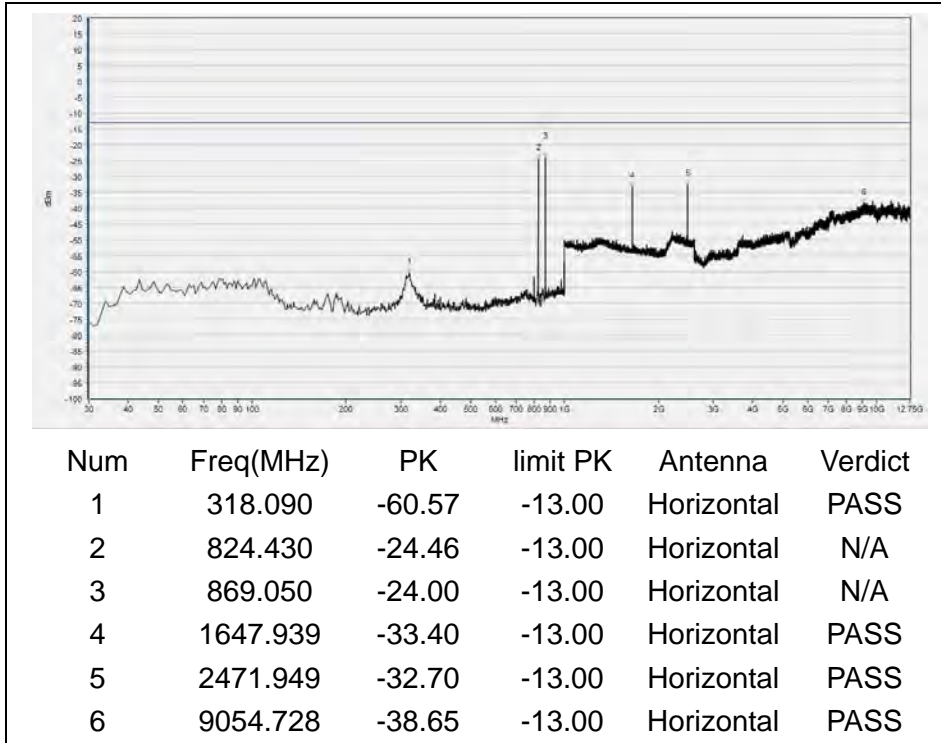

(Plot A1, GPRS 850MHz, Channel = 128, Horizontal)

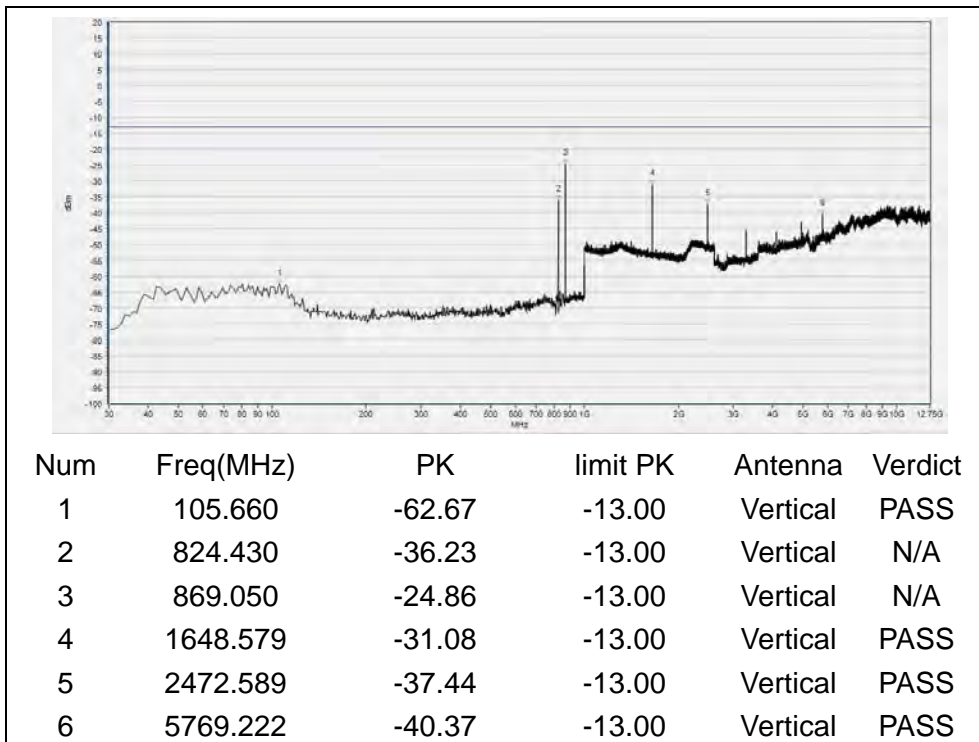

(Plot A2, GPRS 850MHz, Channel = 128, Vertical)

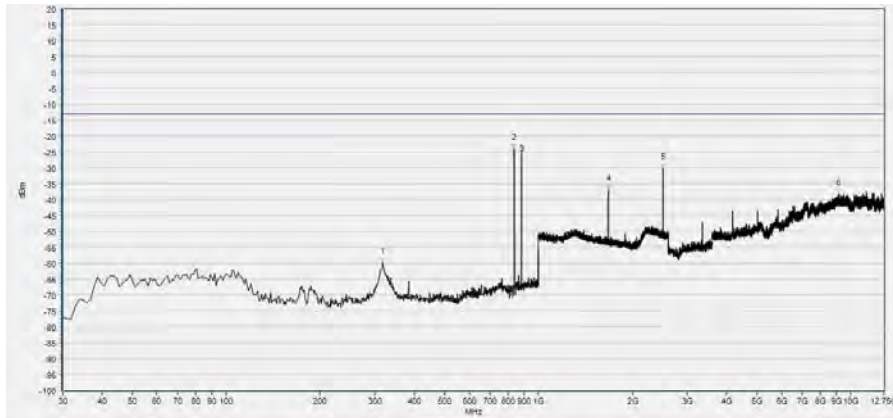

Num	Freq(MHz)	PK	limit PK	Antenna	Verdict
1	317.120	-59.77	-13.00	Horizontal	PASS
2	836.070	-24.05	-13.00	Horizontal	N/A
3	881.660	-24.44	-13.00	Horizontal	N/A
4	1672.909	-36.92	-13.00	Horizontal	PASS
5	2509.724	-30.22	-13.00	Horizontal	PASS
6	9137.789	-38.30	-13.00	Horizontal	PASS

(Plot A3, GPRS850MHz, Channel = 190, Horizontal)

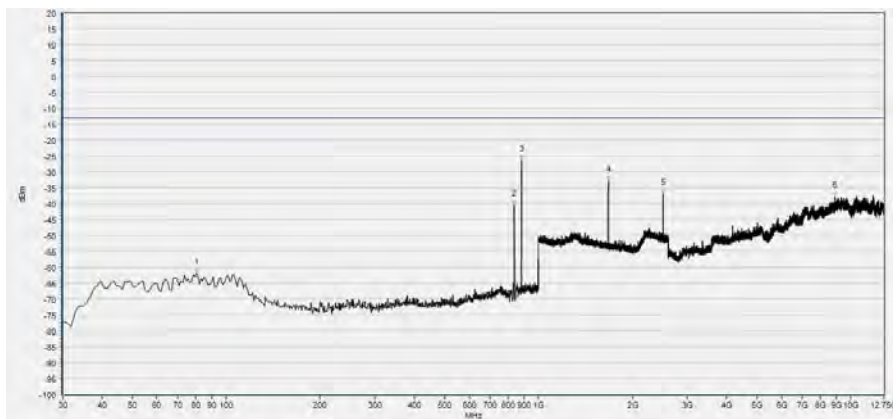

Num	Freq(MHz)	PK	limit PK	Antenna	Verdict
1	80.440	-61.89	-13.00	Vertical	PASS
2	837.040	-40.39	-13.00	Vertical	N/A
3	881.660	-26.54	-13.00	Vertical	N/A
4	1672.909	-32.89	-13.00	Vertical	PASS
5	2509.724	-36.83	-13.00	Vertical	PASS
6	8899.682	-37.77	-13.00	Vertical	PASS

(Plot A4, GPRS 850MHz, Channel = 190, Vertical)

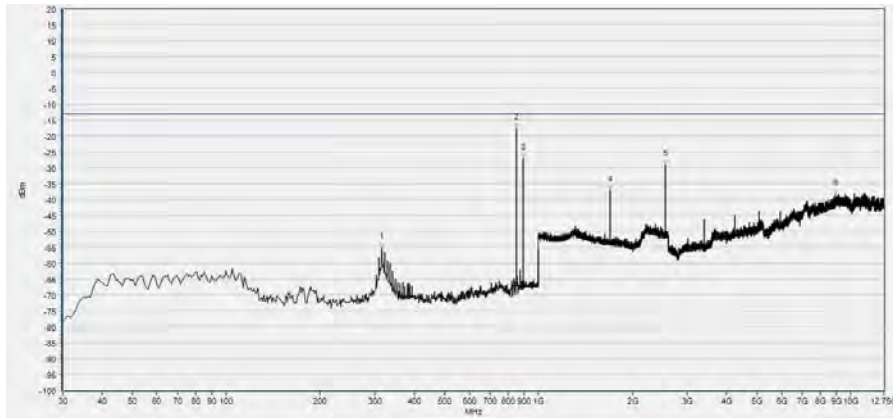

Num	Freq(MHz)	PK	limit PK	Antenna	Verdict
1	315.180	-55.13	-13.00	Horizontal	PASS
2	848.680	-17.51	-13.00	Horizontal	N/A
3	894.270	-27.20	-13.00	Horizontal	N/A
4	1697.239	-37.10	-13.00	Horizontal	PASS
5	2546.218	-28.98	-13.00	Horizontal	PASS
6	8921.831	-38.26	-13.00	Horizontal	PASS

(Plot A5, GPRS 850MHz, Channel = 251, Horizontal)

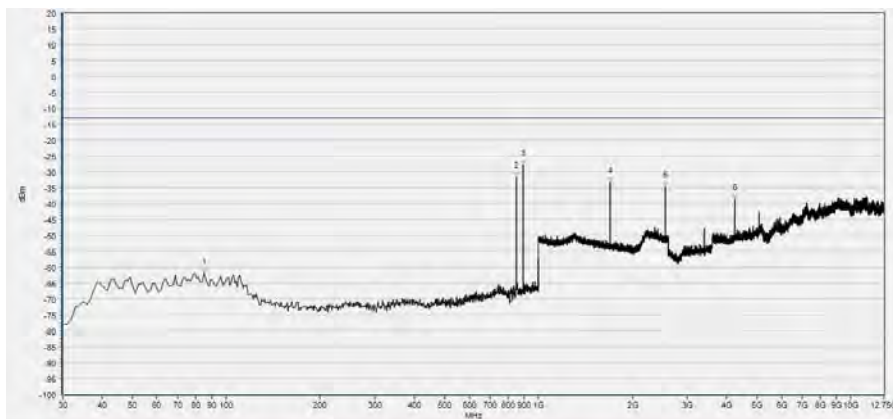

Num	Freq(MHz)	PK	limit PK	Antenna	Verdict
1	85.290	-61.82	-13.00	Vertical	PASS
2	848.680	-31.75	-13.00	Vertical	N/A
3	893.300	-27.85	-13.00	Vertical	N/A
4	1697.239	-33.25	-13.00	Vertical	PASS
5	2546.218	-34.79	-13.00	Vertical	PASS
6	4244.599	-38.50	-13.00	Vertical	PASS

(Plot A6, GPRS 850MHz, Channel = 251, Vertical)

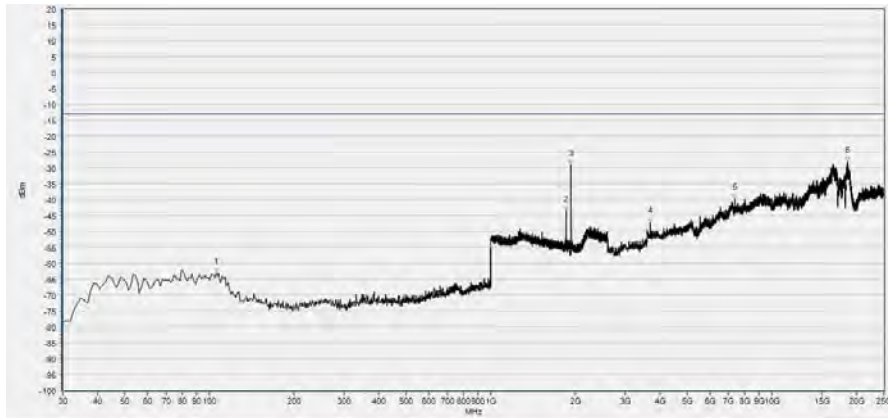

Num	Freq(MHz)	PK	limit PK	Antenna	Verdict
1	105.660	-63.01	-13.00	Horizontal	PASS
2	1850.260	-43.67	-13.00	Horizontal	N/A
3	1930.292	-29.13	-13.00	Horizontal	N/A
4	3699.836	-47.06	-13.00	Horizontal	PASS
5	7402.619	-39.70	-13.00	Horizontal	PASS
6	18555.774	-28.11	-13.00	Horizontal	PASS

(Plot B1, GPRS 1900MHz, Channel = 512, Horizontal)

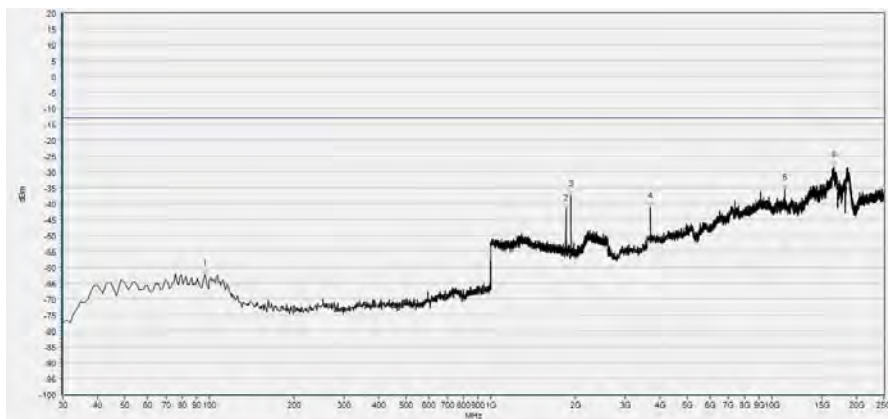

Num	Freq(MHz)	PK	limit PK	Antenna	Verdict
1	95.960	-62.43	-13.00	Vertical	PASS
2	1849.620	-41.87	-13.00	Vertical	N/A
3	1929.652	-37.35	-13.00	Vertical	N/A
4	3699.836	-41.20	-13.00	Vertical	PASS
5	11101.328	-35.38	-13.00	Vertical	PASS
6	16567.921	-28.38	-13.00	Vertical	PASS

(Plot B2, GPRS 1900MHz, Channel = 512, Vertical)

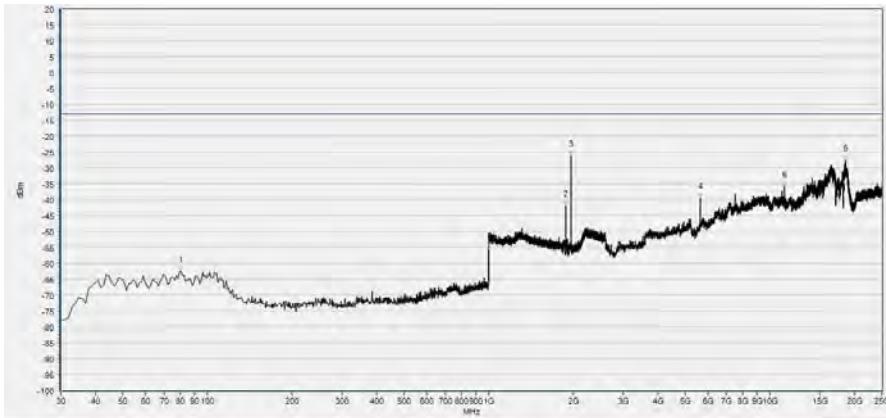

Num	Freq(MHz)	PK	limit PK	Antenna	Verdict
1	80.440	-62.52	-13.00	Horizontal	PASS
2	1879.712	-41.91	-13.00	Horizontal	N/A
3	1959.744	-26.21	-13.00	Horizontal	N/A
4	5638.807	-39.59	-13.00	Horizontal	PASS
5	11280.560	-36.03	-13.00	Horizontal	PASS
6	18576.141	-27.55	-13.00	Horizontal	PASS

(Plot B3, GPRS 1900MHz, Channel = 661, Horizontal)

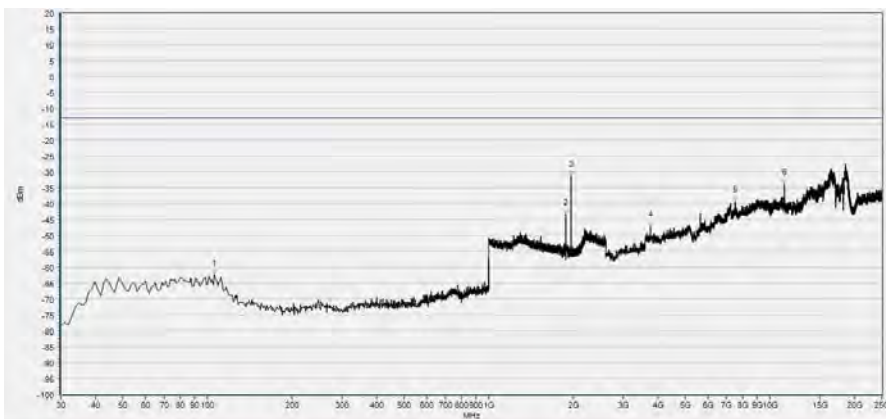

Num	Freq(MHz)	PK	limit PK	Antenna	Verdict
1	105.660	-62.27	-13.00	Vertical	PASS
2	1879.712	-43.36	-13.00	Vertical	N/A
3	1959.744	-31.29	-13.00	Vertical	N/A
4	3760.938	-47.21	-13.00	Vertical	PASS
5	7520.749	-39.19	-13.00	Vertical	PASS
6	11280.560	-33.79	-13.00	Vertical	PASS

(Plot B4, GPRS 1900MHz, Channel = 661, Vertical)

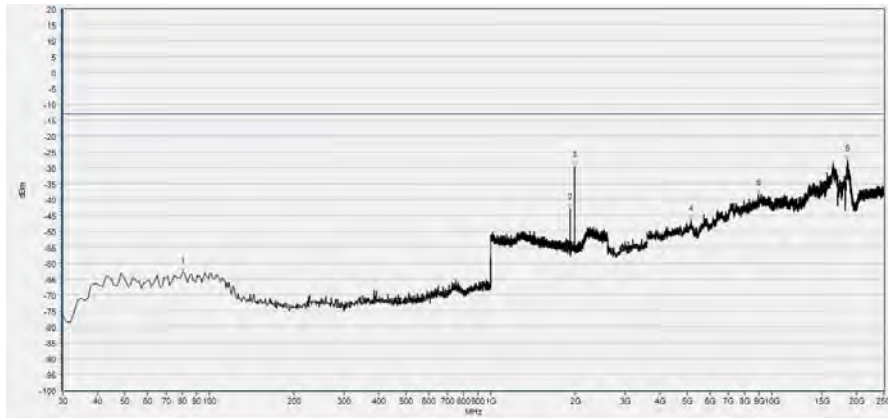

Num	Freq(MHz)	PK	limit PK	Antenna	Verdict
1	80.440	-62.92	-13.00	Horizontal	PASS
2	1909.804	-42.96	-13.00	Horizontal	N/A
3	1989.836	-29.63	-13.00	Horizontal	N/A
4	5162.211	-46.39	-13.00	Horizontal	PASS
5	8938.316	-38.23	-13.00	Horizontal	PASS
6	18576.141	-27.62	-13.00	Horizontal	PASS

(Plot B5, GPRS 1900MHz, Channel = 810, Horizontal)

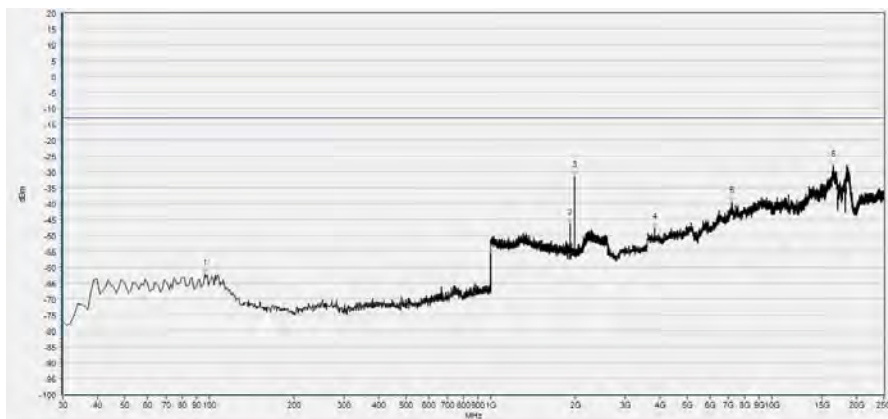

Num	Freq(MHz)	PK	limit PK	Antenna	Verdict
1	95.960	-62.16	-13.00	Vertical	PASS
2	1909.804	-46.54	-13.00	Vertical	N/A
3	1989.836	-31.52	-13.00	Vertical	N/A
4	3817.967	-47.58	-13.00	Vertical	PASS
5	7194.872	-39.49	-13.00	Vertical	PASS
6	16531.260	-28.15	-13.00	Vertical	PASS

(Plot B6, GPRS 1900MHz, Channel = 810, Vertical)

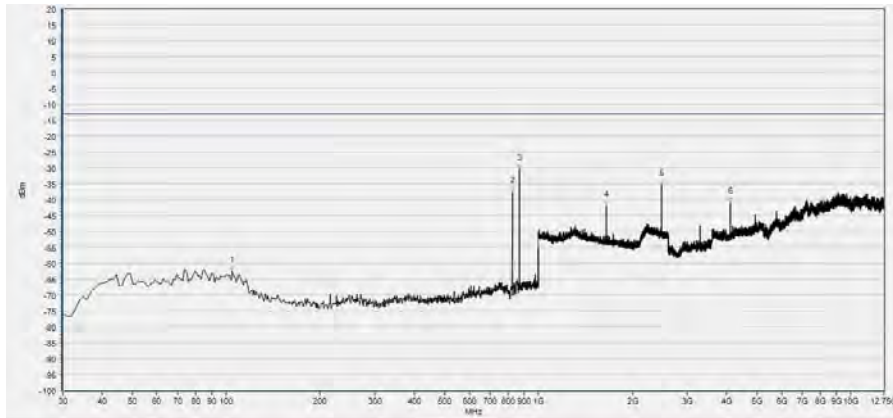

Num	Freq(MHz)	PK	limit PK	Antenna	Verdict
1	104.690	-62.69	-13.00	Horizontal	PASS
2	824.430	-37.56	-13.00	Horizontal	N/A
3	869.050	-30.37	-13.00	Horizontal	N/A
4	1648.579	-41.98	-13.00	Horizontal	PASS
5	2471.949	-35.35	-13.00	Horizontal	PASS
6	4120.931	-41.03	-13.00	Horizontal	PASS

(Plot C1, EGPRS 850MHz, Channel = 128, Horizontal)

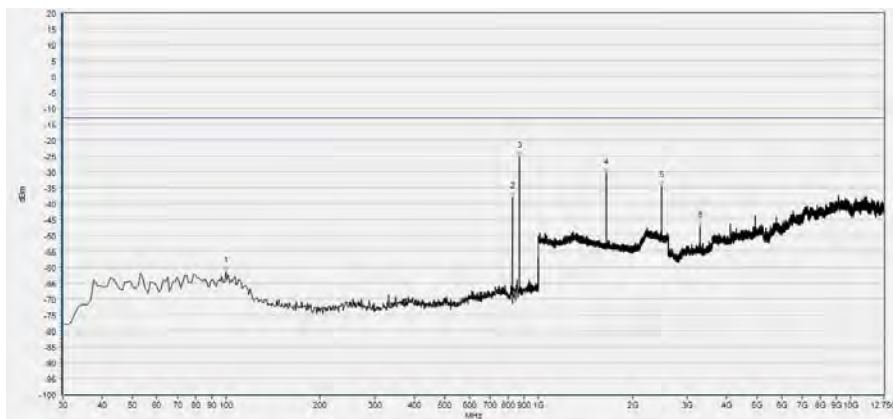

Num	Freq(MHz)	PK	limit PK	Antenna	Verdict
1	99.840	-61.48	-13.00	Vertical	PASS
2	824.430	-38.20	-13.00	Vertical	N/A
3	869.050	-25.33	-13.00	Vertical	N/A
4	1648.579	-30.56	-13.00	Vertical	PASS
5	2472.589	-34.64	-13.00	Vertical	PASS
6	3295.863	-47.26	-13.00	Vertical	PASS

(Plot C2, EGPRS 850MHz, Channel = 128, Vertical)

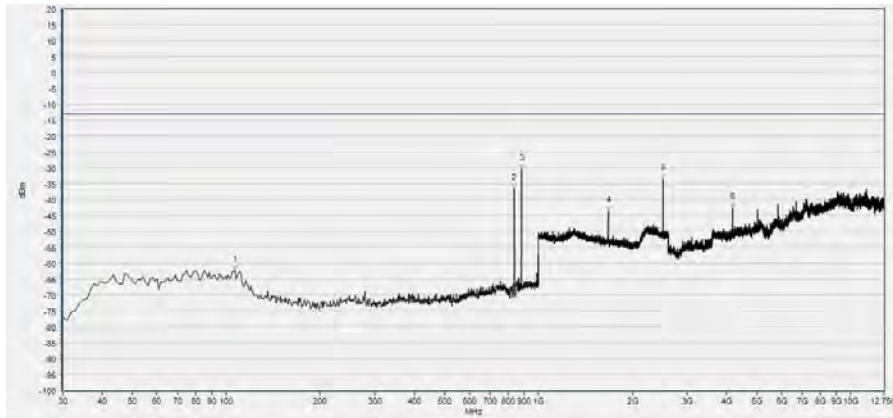

Num	Freq(MHz)	PK	limit PK	Antenna	Verdict
1	106.630	-62.27	-13.00	Horizontal	PASS
2	836.070	-36.64	-13.00	Horizontal	N/A
3	881.660	-30.47	-13.00	Horizontal	N/A
4	1672.909	-43.54	-13.00	Horizontal	PASS
5	2509.724	-33.51	-13.00	Horizontal	PASS
6	4183.688	-42.65	-13.00	Horizontal	PASS

(Plot C3, EGPRS 850MHz, Channel = 190, Horizontal)

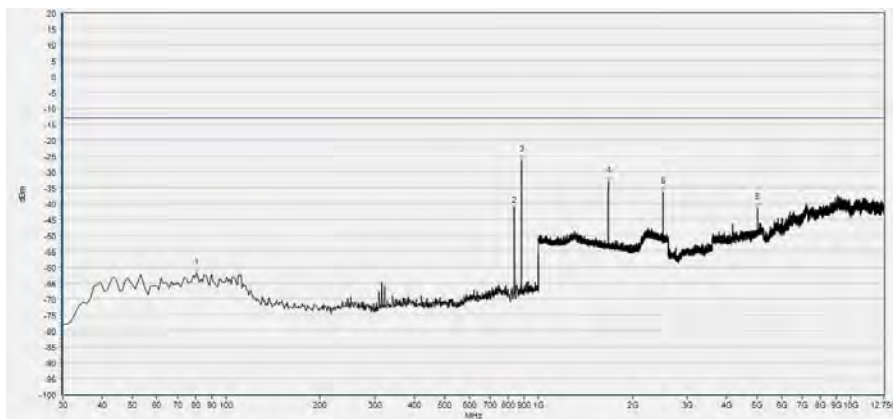

Num	Freq(MHz)	PK	limit PK	Antenna	Verdict
1	80.440	-61.82	-13.00	Vertical	PASS
2	836.070	-42.62	-13.00	Vertical	N/A
3	881.660	-26.41	-13.00	Vertical	N/A
4	1672.909	-33.17	-13.00	Vertical	PASS
5	2509.724	-36.34	-13.00	Vertical	PASS
6	5019.831	-41.34	-13.00	Vertical	PASS

(Plot C4, EGPRS 850MHz, Channel = 190, Vertical)

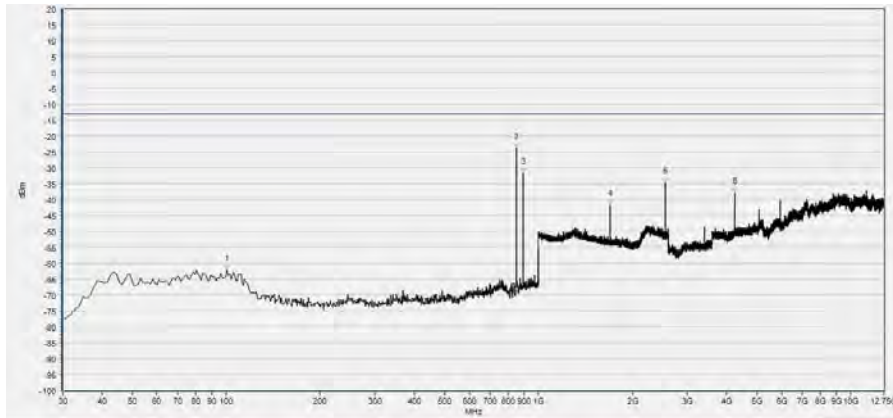

Num	Freq(MHz)	PK	limit PK	Antenna	Verdict
1	100.810	-62.12	-13.00	Horizontal	PASS
2	848.680	-23.90	-13.00	Horizontal	N/A
3	893.300	-31.71	-13.00	Horizontal	N/A
4	1697.879	-41.69	-13.00	Horizontal	PASS
5	2546.218	-34.83	-13.00	Horizontal	PASS
6	4244.599	-37.74	-13.00	Horizontal	PASS

(Plot C5, EGPRS 850MHz, Channel = 251, Horizontal)

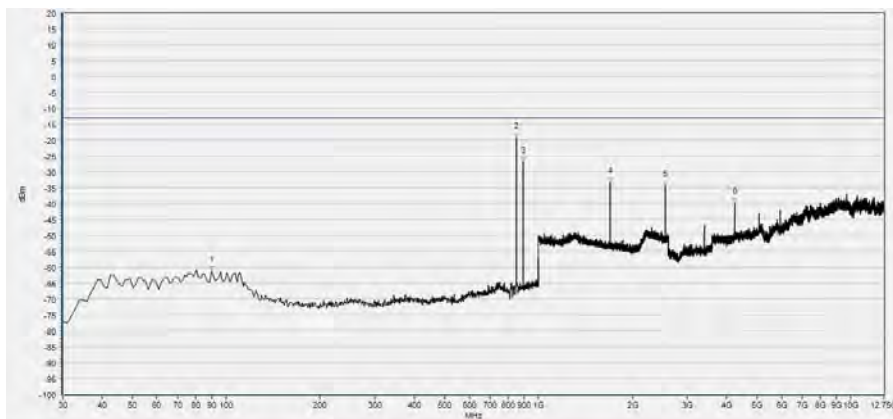

Num	Freq(MHz)	PK	limit PK	Antenna	Verdict
1	90.140	-61.20	-13.00	Vertical	PASS
2	848.680	-19.29	-13.00	Vertical	N/A
3	893.300	-26.89	-13.00	Vertical	N/A
4	1697.239	-33.30	-13.00	Vertical	PASS
5	2546.218	-34.23	-13.00	Vertical	PASS
6	4244.599	-39.74	-13.00	Vertical	PASS

(Plot C6, EGPRS 850MHz, Channel = 251, Vertical)

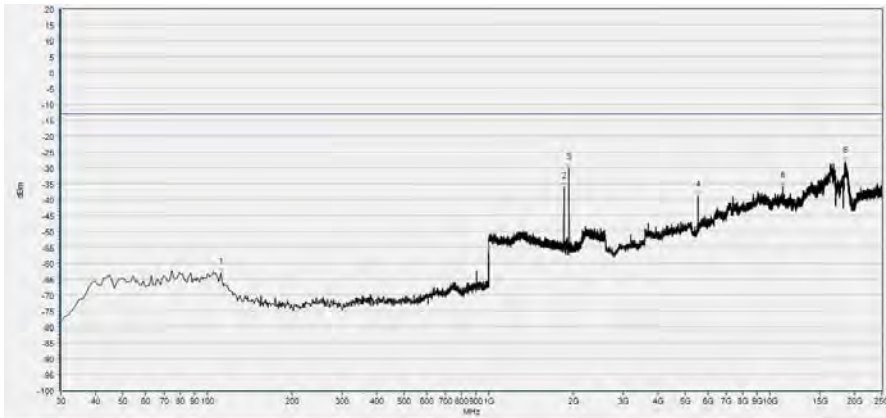

Num	Freq(MHz)	PK	limit PK	Antenna	Verdict
1	111.480	-63.03	-13.00	Horizontal	PASS
2	1850.260	-36.26	-13.00	Horizontal	N/A
3	1930.292	-30.31	-13.00	Horizontal	N/A
4	5549.191	-38.82	-13.00	Horizontal	PASS
5	11101.328	-35.89	-13.00	Horizontal	PASS
6	18584.288	-28.13	-13.00	Horizontal	PASS

(Plot D1, EGPRS 1900MHz, Channel = 512, Horizontal)

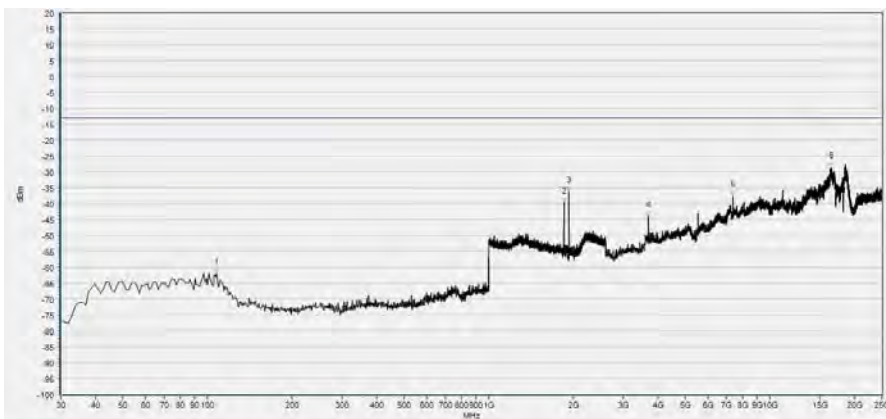

Num	Freq(MHz)	PK	limit PK	Antenna	Verdict
1	107.600	-61.95	-13.00	Vertical	PASS
2	1849.620	-39.66	-13.00	Vertical	N/A
3	1929.652	-36.14	-13.00	Vertical	N/A
4	3699.836	-44.03	-13.00	Vertical	PASS
5	7402.619	-37.52	-13.00	Vertical	PASS
6	16555.701	-28.68	-13.00	Vertical	PASS

(Plot D2, EGPRS 1900MHz, Channel = 512, Vertical)

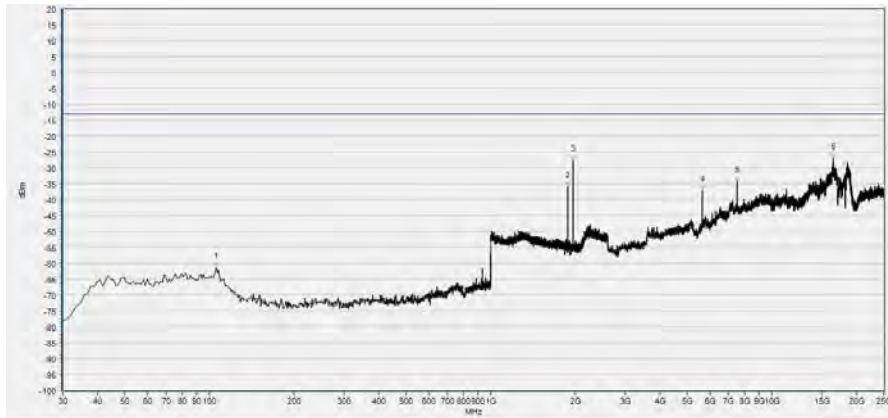

Num	Freq(MHz)	PK	limit PK	Antenna	Verdict
1	105.660	-61.42	-13.00	Horizontal	PASS
2	1879.712	-35.85	-13.00	Horizontal	N/A
3	1959.744	-27.60	-13.00	Horizontal	N/A
4	5638.807	-37.19	-13.00	Horizontal	PASS
5	7520.749	-34.38	-13.00	Horizontal	PASS
6	16523.113	-26.98	-13.00	Horizontal	PASS

(Plot D3, EGPRS 1900MHz, Channel = 661, Horizontal)

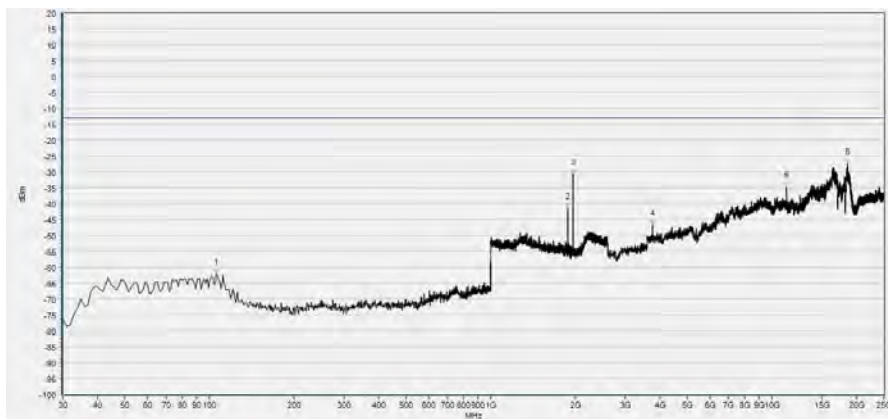

Num	Freq(MHz)	PK	limit PK	Antenna	Verdict
1	105.660	-62.26	-13.00	Vertical	PASS
2	1879.712	-41.45	-13.00	Vertical	N/A
3	1959.744	-30.72	-13.00	Vertical	N/A
4	3760.938	-46.58	-13.00	Vertical	PASS
5	11280.560	-34.70	-13.00	Vertical	PASS
6	18551.700	-27.50	-13.00	Vertical	PASS

(Plot D4, EGPRS 1900MHz, Channel = 661, Vertical)

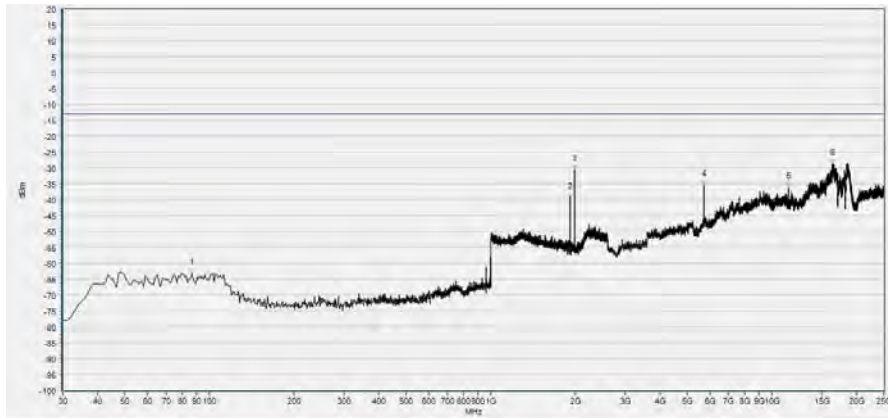

Num	Freq(MHz)	PK	limit PK	Antenna	Verdict
1	86.260	-63.24	-13.00	Horizontal	PASS
2	1909.164	-39.59	-13.00	Horizontal	N/A
3	1989.836	-30.62	-13.00	Horizontal	N/A
4	5728.423	-35.47	-13.00	Horizontal	PASS
5	11459.793	-36.18	-13.00	Horizontal	PASS
6	16396.836	-28.88	-13.00	Horizontal	PASS

(Plot D5, EGPRS 1900MHz, Channel = 810, Horizontal)

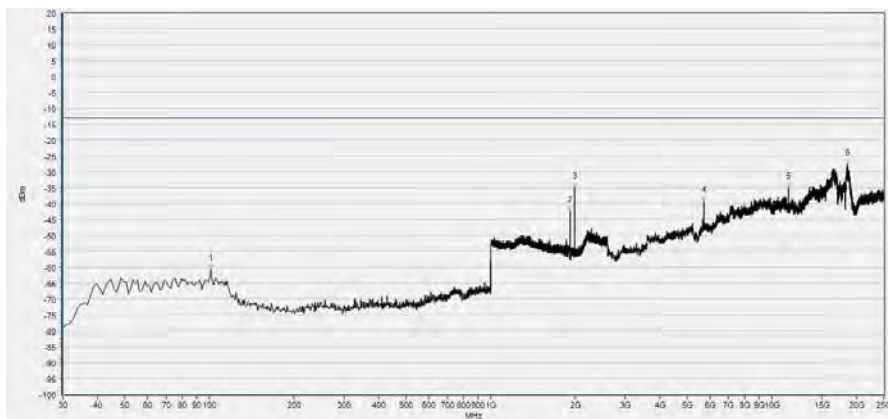

Num	Freq(MHz)	PK	limit PK	Antenna	Verdict
1	100.810	-60.64	-13.00	Vertical	PASS
2	1909.804	-42.35	-13.00	Vertical	N/A
3	1989.836	-35.05	-13.00	Vertical	N/A
4	5728.423	-39.29	-13.00	Vertical	PASS
5	11459.793	-34.96	-13.00	Vertical	PASS
6	18580.215	-27.73	-13.00	Vertical	PASS

(Plot D6, EGPRS 1900MHz, Channel = 810, Vertical)

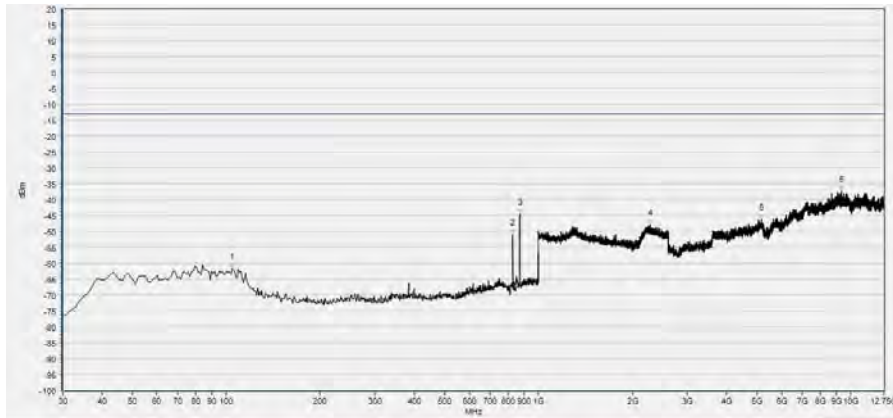

Num	Freq(MHz)	PK	limit PK	Antenna	Verdict
1	104.690	-61.78	-13.00	Horizontal	PASS
2	827.340	-50.91	-13.00	Horizontal	N/A
3	872.930	-44.61	-13.00	Horizontal	N/A
4	2282.433	-47.86	-13.00	Horizontal	PASS
5	5182.260	-46.23	-13.00	Horizontal	PASS
6	9322.368	-37.35	-13.00	Horizontal	PASS

(Plot E1, WCDMA 850MHz, Channel = 4132, Horizontal)

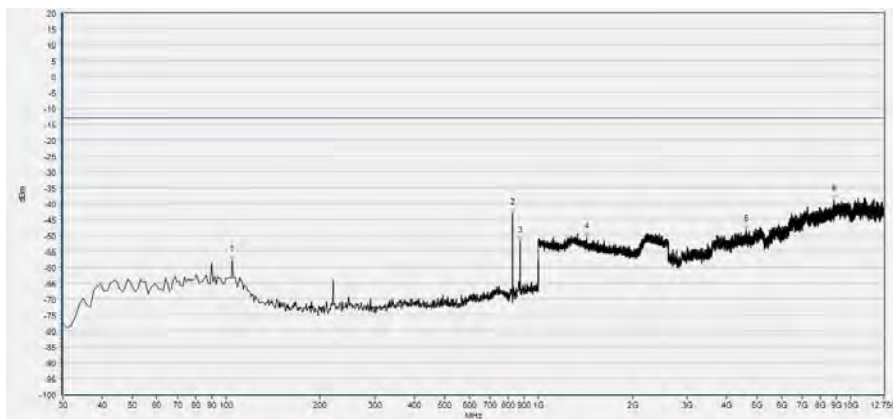

Num	Freq(MHz)	PK	limit PK	Antenna	Verdict
1	104.690	-57.89	-13.00	Vertical	PASS
2	827.340	-43.20	-13.00	Vertical	N/A
3	872.930	-52.33	-13.00	Vertical	N/A
4	1424.490	-50.72	-13.00	Vertical	PASS
5	4624.832	-48.22	-13.00	Vertical	PASS
6	8844.308	-38.77	-13.00	Vertical	PASS

(Plot E2, WCDMA 850MHz, Channel = 4132, Vertical)

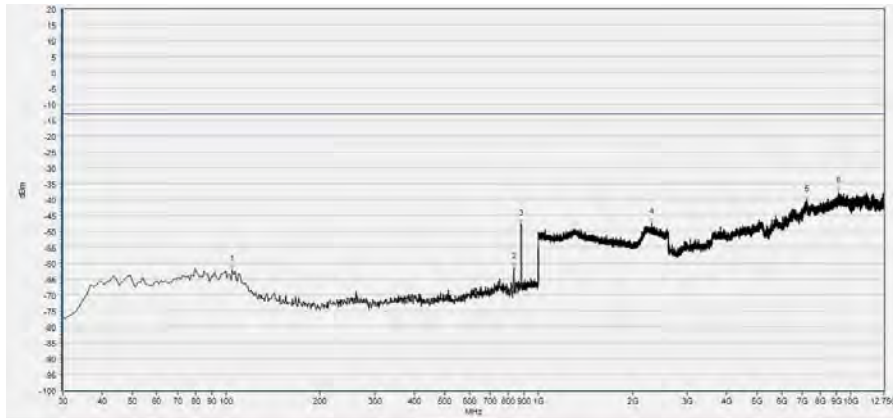

Num	Freq(MHz)	PK	limit PK	Antenna	Verdict
1	104.690	-62.15	-13.00	Horizontal	PASS
2	834.130	-61.53	-13.00	Horizontal	N/A
3	877.780	-47.92	-13.00	Horizontal	N/A
4	2301.641	-47.29	-13.00	Horizontal	PASS
5	7218.167	-40.13	-13.00	Horizontal	PASS
6	9143.326	-37.53	-13.00	Horizontal	PASS

(Plot E3, WCDMA 850MHz, Channel = 4175, Horizontal)

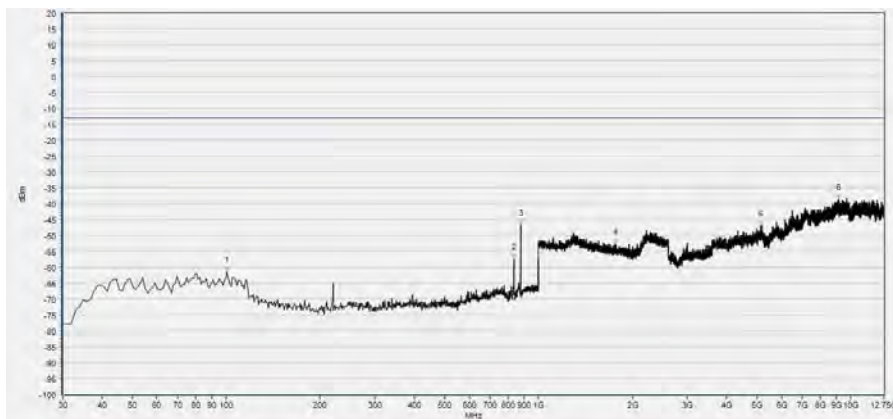

Num	Freq(MHz)	PK	limit PK	Antenna	Verdict
1	100.810	-61.39	-13.00	Vertical	PASS
2	834.130	-57.38	-13.00	Vertical	N/A
3	876.810	-46.66	-13.00	Vertical	N/A
4	1763.826	-52.57	-13.00	Vertical	PASS
5	5139.807	-46.92	-13.00	Vertical	PASS
6	9104.564	-38.58	-13.00	Vertical	PASS

(Plot E4, WCDMA 850MHz, Channel = 4175, Vertical)

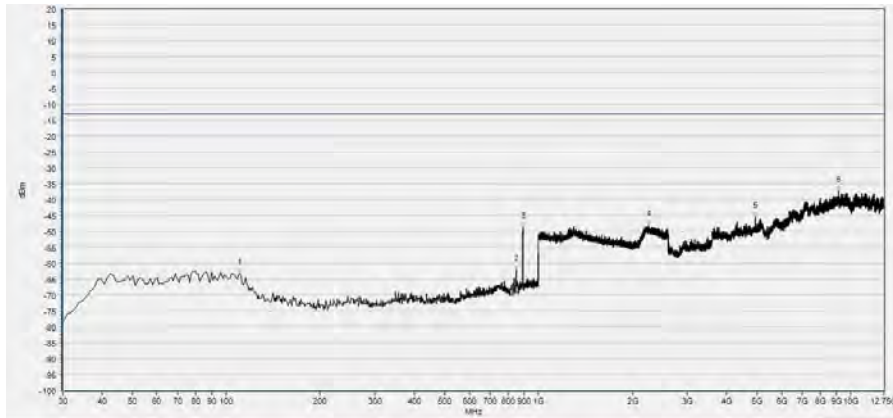

Num	Freq(MHz)	PK	limit PK	Antenna	Verdict
1	110.510	-63.22	-13.00	Horizontal	PASS
2	847.710	-62.12	-13.00	Horizontal	N/A
3	891.360	-48.88	-13.00	Horizontal	N/A
4	2247.859	-48.00	-13.00	Horizontal	PASS
5	4955.228	-45.53	-13.00	Horizontal	PASS
6	9128.560	-37.48	-13.00	Horizontal	PASS

(Plot E5, WCDMA 850MHz, Channel = 4233, Horizontal)

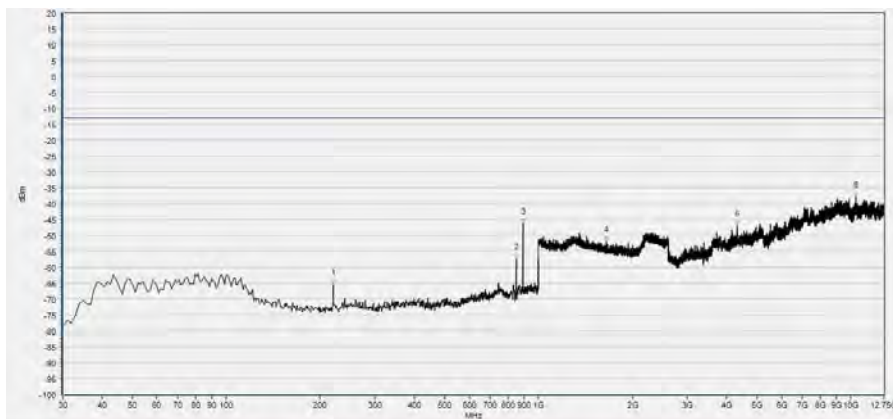

Num	Freq(MHz)	PK	limit PK	Antenna	Verdict
1	220.120	-65.40	-13.00	Vertical	PASS
2	847.710	-57.46	-13.00	Vertical	N/A
3	891.360	-46.30	-13.00	Vertical	N/A
4	1647.299	-51.97	-13.00	Vertical	PASS
5	4325.814	-46.96	-13.00	Vertical	PASS
6	10376.314	-37.87	-13.00	Vertical	PASS

(Plot E6, WCDMA 850MHz, Channel = 4233, Vertical)

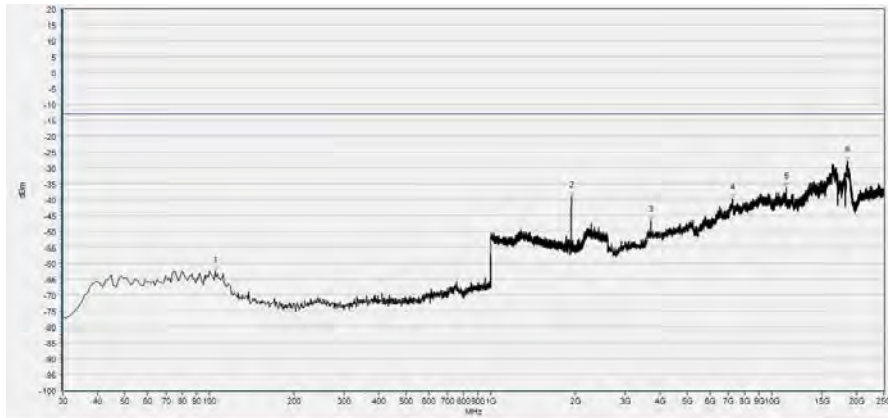

Num	Freq(MHz)	PK	limit PK	Antenna	Verdict
1	104.690	-62.67	-13.00	Horizontal	PASS
2	1932.853	-39.10	-13.00	Horizontal	N/A
3	3707.983	-46.69	-13.00	Horizontal	PASS
4	7231.533	-39.75	-13.00	Horizontal	PASS
5	11219.458	-36.17	-13.00	Horizontal	PASS
6	18527.260	-27.79	-13.00	Horizontal	PASS

(Plot G1, WCDMA 1900MHz, Channel = 9262, Horizontal)

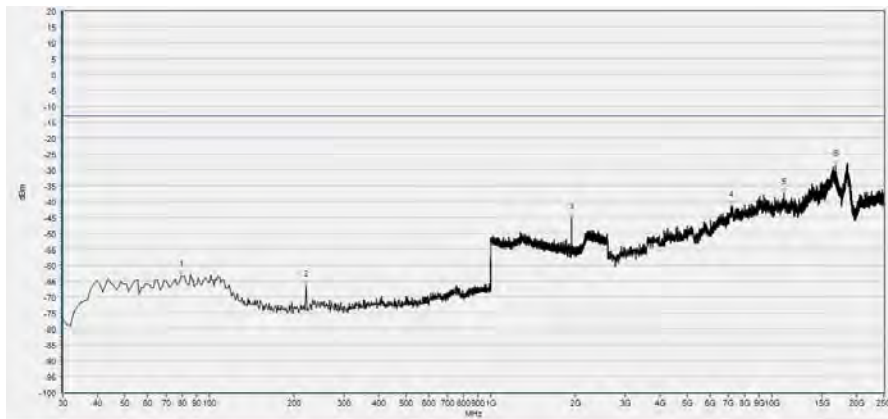

Num	Freq(MHz)	PK	limit PK	Antenna	Verdict
1	79.470	-63.30	-13.00	Vertical	PASS
2	220.120	-66.48	-13.00	Vertical	PASS
3	1932.213	-45.23	-13.00	Vertical	N/A
4	7166.358	-41.41	-13.00	Vertical	PASS
5	11048.372	-37.42	-13.00	Vertical	PASS
6	16808.256	-28.64	-13.00	Vertical	PASS

(Plot G2, WCDMA 1900MHz, Channel = 9262, Vertical)

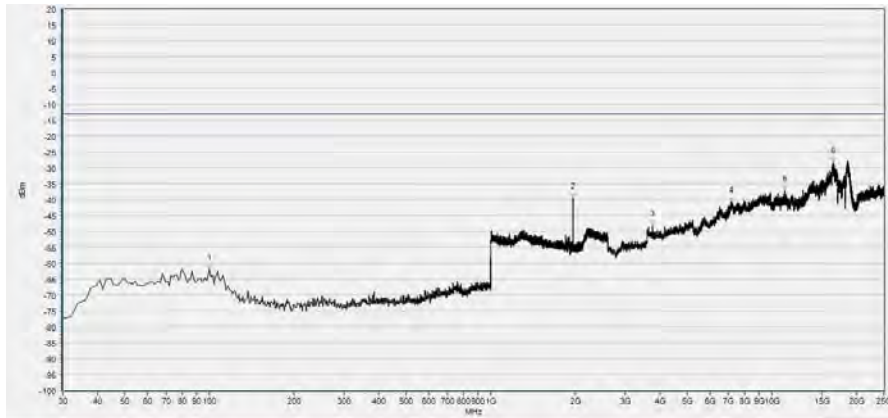

Num	Freq(MHz)	PK	limit PK	Antenna	Verdict
1	99.840	-61.79	-13.00	Horizontal	PASS
2	1959.744	-39.60	-13.00	Horizontal	N/A
3	3756.865	-48.04	-13.00	Horizontal	PASS
4	7141.917	-40.74	-13.00	Horizontal	PASS
5	11085.034	-37.18	-13.00	Horizontal	PASS
6	16502.746	-28.43	-13.00	Horizontal	PASS

(Plot G3, WCDMA 1900MHz, Channel = 9400, Horizontal)

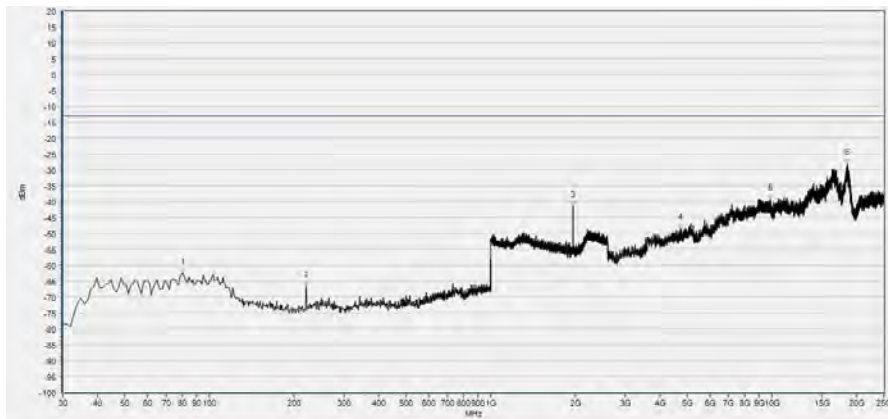

Num	Freq(MHz)	PK	limit PK	Antenna	Verdict
1	80.440	-62.70	-13.00	Vertical	PASS
2	220.120	-66.69	-13.00	Vertical	PASS
3	1959.744	-41.47	-13.00	Vertical	N/A
4	4718.203	-48.51	-13.00	Vertical	PASS
5	9854.846	-39.29	-13.00	Vertical	PASS
6	18559.847	-28.03	-13.00	Vertical	PASS

(Plot G4, WCDMA 1900MHz, Channel = 9400, Vertical)

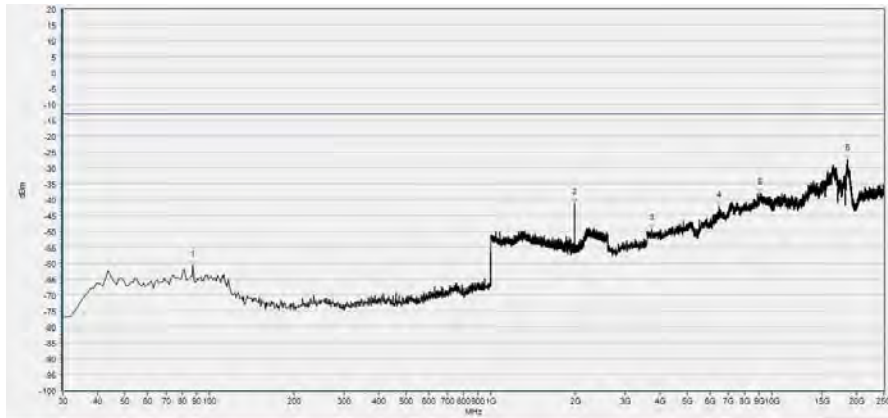

Num	Freq(MHz)	PK	limit PK	Antenna	Verdict
1	87.230	-60.80	-13.00	Horizontal	PASS
2	1987.275	-41.10	-13.00	Horizontal	N/A
3	3728.351	-49.37	-13.00	Horizontal	PASS
4	6465.721	-42.13	-13.00	Horizontal	PASS
5	9072.740	-38.05	-13.00	Horizontal	PASS
6	18563.921	-27.47	-13.00	Horizontal	PASS

(Plot G5, WCDMA 1900MHz, Channel = 9538, Horizontal)

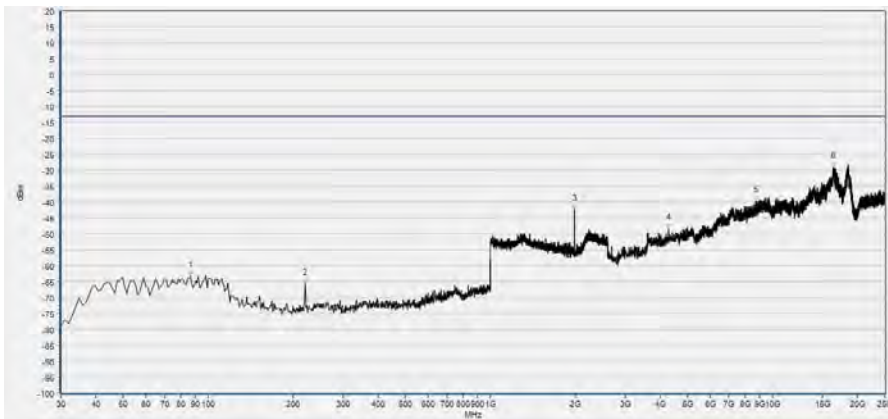

Num	Freq(MHz)	PK	limit PK	Antenna	Verdict
1	86.260	-63.44	-13.00	Vertical	PASS
2	220.120	-65.82	-13.00	Vertical	PASS
3	1987.915	-42.48	-13.00	Vertical	N/A
4	4282.342	-48.26	-13.00	Vertical	PASS
5	8718.349	-39.72	-13.00	Vertical	PASS
6	16425.350	-29.13	-13.00	Vertical	PASS

(Plot G6, WCDMA 1900MHz, Channel = 9538, Vertical)



Annex A Test Uncertainty

Where relevant, the following measurement uncertainty levels have been estimated for test performed on the EUT as specified in CISPR 16-1-2:

Test items	Uncertainty
Output Power	$\pm 2.22\text{dB}$
Bandwidth	$\pm 5\%$
Conducted Spurious Emission	$\pm 2.77\text{ dB}$
Radiated Emission	$\pm 2.95\text{dB}$

This uncertainty represent an expanded uncertainty expressed at approximately the 95% confidence level using a coverage factor of $k=2$



Annex B Testing Laboratory Information

1. Identification of the Responsible Testing Laboratory

Company Name:	Shenzhen Morlab Communications Technology Co., Ltd.
Department:	Morlab Laboratory
Address:	FL.3, Building A, FeiYang Science Park, No.8 LongChang Road, Block 67, BaoAn District, ShenZhen, Guangdong Province, P. R. China
Responsible Test Lab Manager:	Mr. Su Feng
Telephone:	+86 755 36698555
Facsimile:	+86 755 36698525

2. Identification of the Responsible Testing Location

Name:	Shenzhen Morlab Communications Technology Co., Ltd. Morlab Laboratory
Address:	FL.3, Building A, FeiYang Science Park, No.8 LongChang Road, Block 67, BaoAn District, ShenZhen, Guangdong Province, P. R. China

3. Facilities and Accreditations

All measurement facilities used to collect the measurement data are located at FL.3, Building A, FeiYang Science Park, Block 67, BaoAn District, Shenzhen, 518101 P. R. China. The test site is constructed in conformance with the requirements of ANSI C63.10-2013 and CISPR Publication 22; the FCC designation number is CN1192, the test firm registration number is 226174.



4. Test Equipments Utilized

4.1 Conducted Test Equipments

Equipment Name	Serial No.	Type	Manufacturer	Cal. Date	Cal. Due
Power Splitter	NW521	1506A	Weinschel	2018.04.17	2019.04.16
Attenuator 1	(N/A.)	10dB	Resnet	2018.04.17	2019.04.16
Attenuator 2	(N/A.)	3dB	Resnet	2018.04.17	2019.04.16
EXA Signal Analyzer	MY53470836	N9010A	Agilent	2017.12.03	2018.12.02
Wireless synthesizer	MY48364176	8960 -E5515C	Agilent	2018.04.17	2019.04.16
RF cable (30MHz-26GHz)	CB01	RF01	Morlab	N/A	N/A
Coaxial cable	CB02	RF02	Morlab	N/A	N/A
SMA connector	CN01	RF03	HUBER-SUHNER	N/A	N/A
Temperature Chamber	(N/A)	HUT705P	CHONGQING HANBA EXPERIMENTAL EQUIPMENT CO.,LTD	2018.04.17	2019.04.16

4.2 Auxiliary Test Equipment

Equipment Name	Model No.	Brand Name	Manufacturer	Cal.Date	Cal. Due
Computer	T430i	Think Pad	Lenovo	N/A	N/A

4.3 List of Software Used

Description	Manufacturer	Software Version
Test system	Tonscend	V2.6
Power Panel	Agilent	V3.8
MORLAB EMCR V1.2	MORLAB	V 1.0

**4.4 Radiated Test Equipments**

Equipment Name	Serial No.	Type	Manufacturer	Cal. Date	Cal. Due
System Simulator	152038	CMW500	R&S	2018.08.04	2019.08.03
Receiver	MY54130016	N9038A	Agilent	2018.05.18	2019.05.17
Test Antenna - Bi-Log	9163-519	VULB 9163	Schwarzbeck	2018.03.03	2019.03.02
Test Antenna - Horn	9170C-531	BBHA9170	Schwarzbeck	2018.08.06	2019.08.05
Test Antenna - Horn	01774	BBHA 9120D	Schwarzbeck	2018.08.02	2019.08.01
Coaxial cable (N male) (9KHz-30MHz)	CB04	EMC04	Morlab	N/A	N/A
Coaxial cable (N male) (30MHz-26GHz)	CB02	EMC02	Morlab	N/A	N/A
Coaxial cable (N male) (30MHz-26GHz)	CB03	EMC03	Morlab	N/A	N/A
1-18GHz pre-Amplifier	MA02	TS-PR18	Rohde& Schwarz	2018.05.08	2019.05.07
18-26.5GHz pre-Amplifier	MA03	TS-PR18	Rohde& Schwarz	2018.05.08	2019.05.07
Anechoic Chamber	N/A	9m*6m*6m	CRT	2017.11.19	2020.11.18

————— END OF REPORT —————