

JM-C21 GNSS Vehicle Terminal

(User Manual)



Email: Support@Incoon.com

Website: www.Incoon.com

Tracking Platform: [Lncoon App](#)



@Lncoon



@Incoon.gps



+86 13423860204

Part I - Product Introduction

1.1 Product Overview

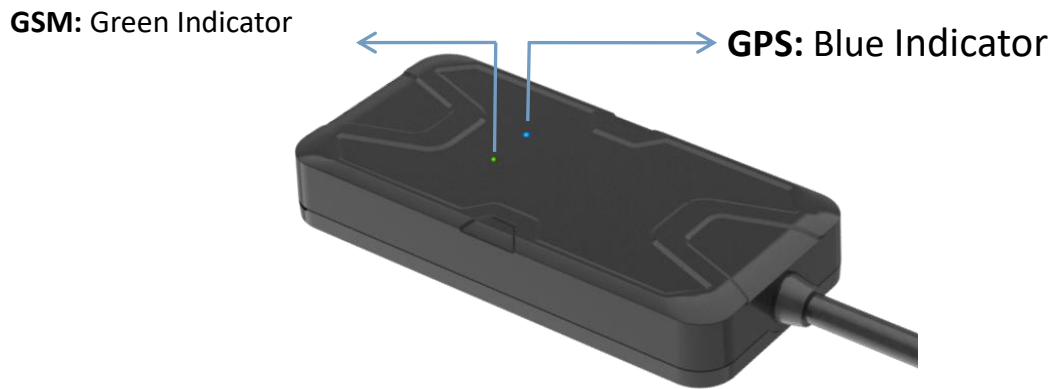

1.2 Product Schematic

No.	Name	Quantity	Unit	Remark
1	Device	1	piece	
2	Power Cable	1	piece	1M length
3	Relay	1	set	
4	User Manual	1	piece	

1.3 Interface Definition

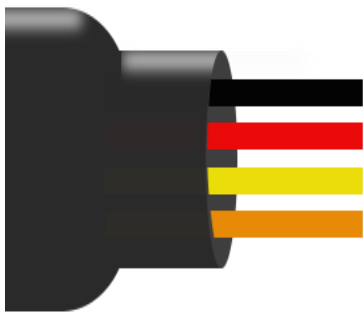

V+	Red	Anode (9-90V)
----	-----	-----------------

V-	Black	Negative
----	-------	----------

ACC	Orange	ACC Detection
-----	--------	---------------

Relay	Yellow	Oil & Power Cut
-------	--------	-----------------

1.4 Indicator Definition

(1) GPS Signal Status

Status	Meaning
Quick Blinking (on 0.3s, off 0.3s)	Searching GPS signal
Solid on	Get GPS Location
Off	Sleep Mode or Not Working

(2) GSM Signal Status

Status	Meaning
Quick Blinking (on 0.3s, off 0.3s)	GSM Initializing
Slow Blinking (on 0.3s, off 2s)	GSM Signal Receiving Normally
Solid on	GSM call/GPRS is active
Off	No signal received

(3) External Power Status

Status	Meaning
Blue&Green Light Solid on 3s	Connected to External Power

Part II - Specification & Features

2.1 Product Specification

Item	Specifications
Tracking	GPS+BDS+LBS
Voltage	9-90V DC
Accuracy	<10m (just for reference)
Battery	60mAh/3.7V lithium polymer battery
Current	≤5mA (Battery powered)
Temperature	-20°C to +35°C
Dimension	71.9 (L) *30.2 (W) * 12.9 (H) mm

2.2 Product Features

Functions	Triggering Conditions
Power Off Alert	Triggered by the Illegal wire cutting
Fall off Alert	Triggered by the attitude of the equipment changes after the terminal is installed to recognize the vehicle attitude
Remove Alert	when the device is removed
Low Battery Alert	Triggered an alarm when the voltage of external power or its own built-in battery current is low
Geo Fence Alert	Triggered an alarm when the terminal enters and exits the designated area
Overspeed Alert	When the vehicle's speed is greater than the speed threshold within the set time

Part III - Product Installation

3.1 Device Installation

(1) Check Device

Confirm whether the appearance of the equipment is good and whether the relevant accessories are complete.

3.2 Wiring Diagram

(1) Use a multimeter to find the battery positive and negative power leads

(2) Use a multimeter to find the ACC line, the judgment method:

The red pen of the multimeter is connected to the ACC line, and the black pen is connected to the negative electrode. When the motorcycle key is in the OFF state, the voltage is 0V. When the motorcycle key is turned ON, the multimeter displays Motorcycle power supply voltage;

(2) The terminal is equipped with the red wire (positive pole) of the power cord and the positive pole of the motorcycle battery;

(4) Insert the connector as shown above.

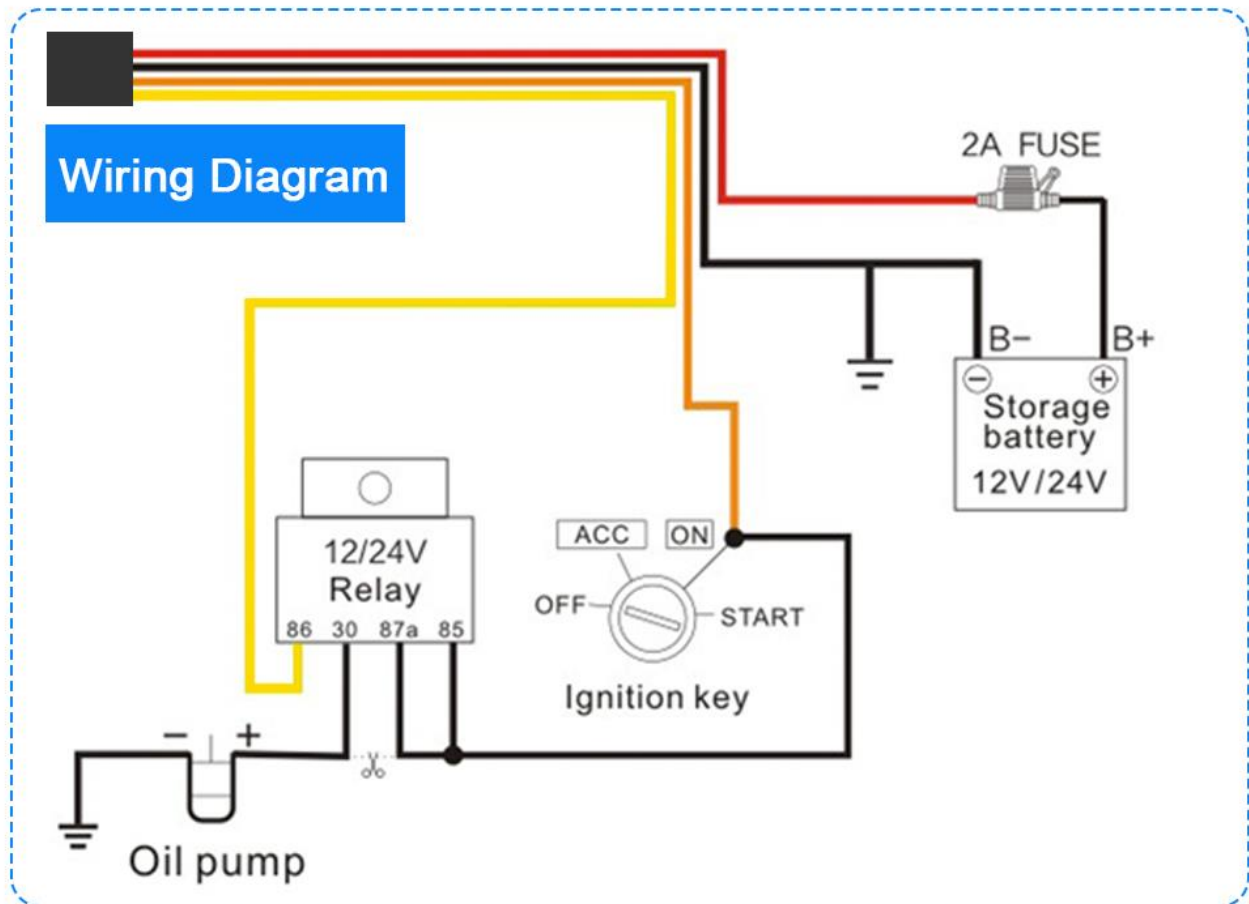

3.3 Electric Vehicle Installation Position

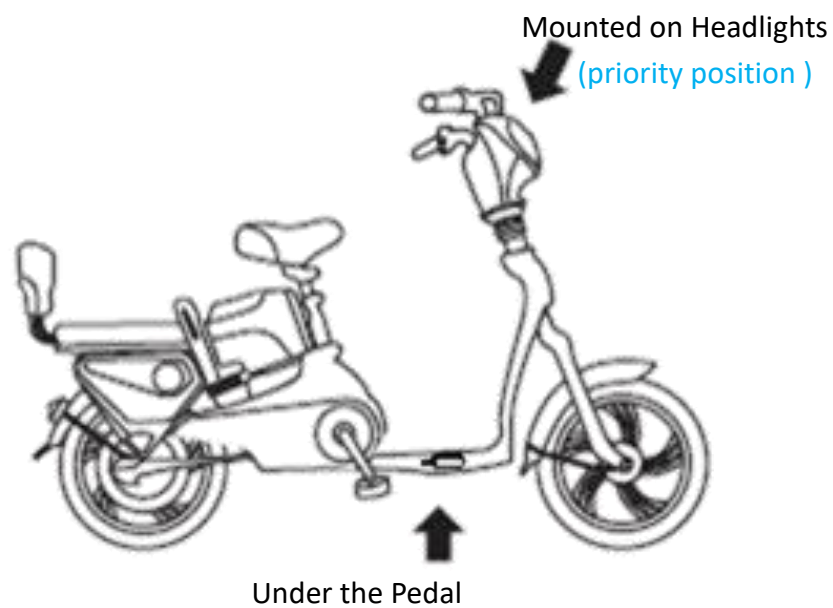

3.4 Motorcycle Installation Position

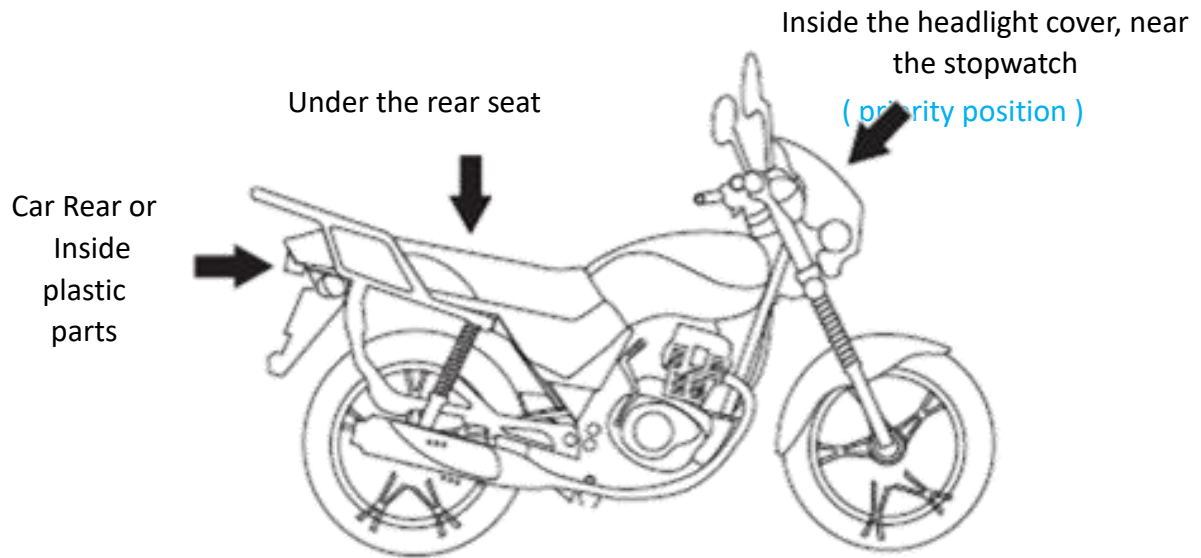

Note: the satellites signal will greatly degrade if be installed under the driver

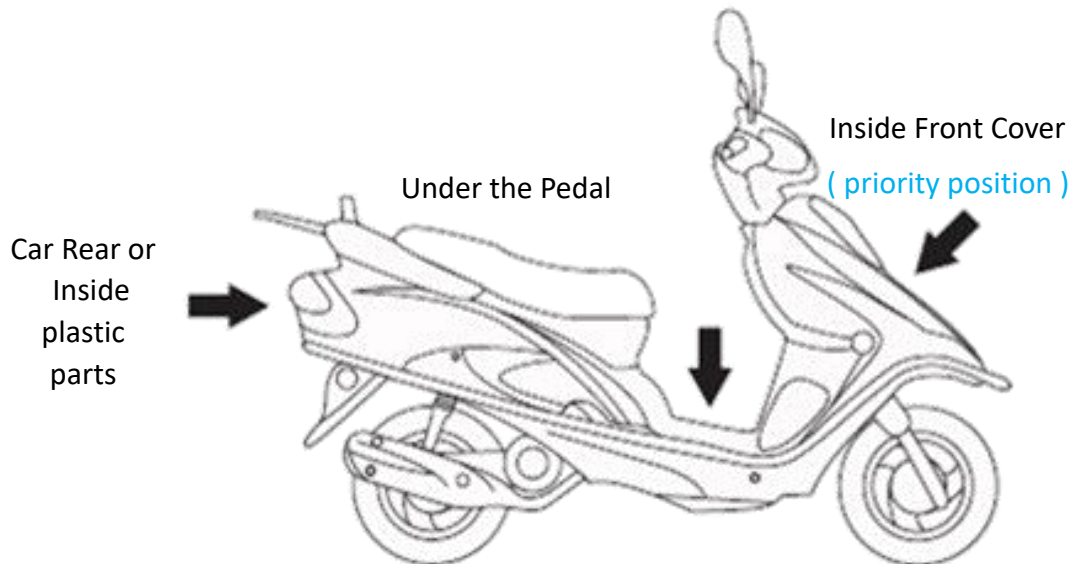

3.5 Car Installation Position

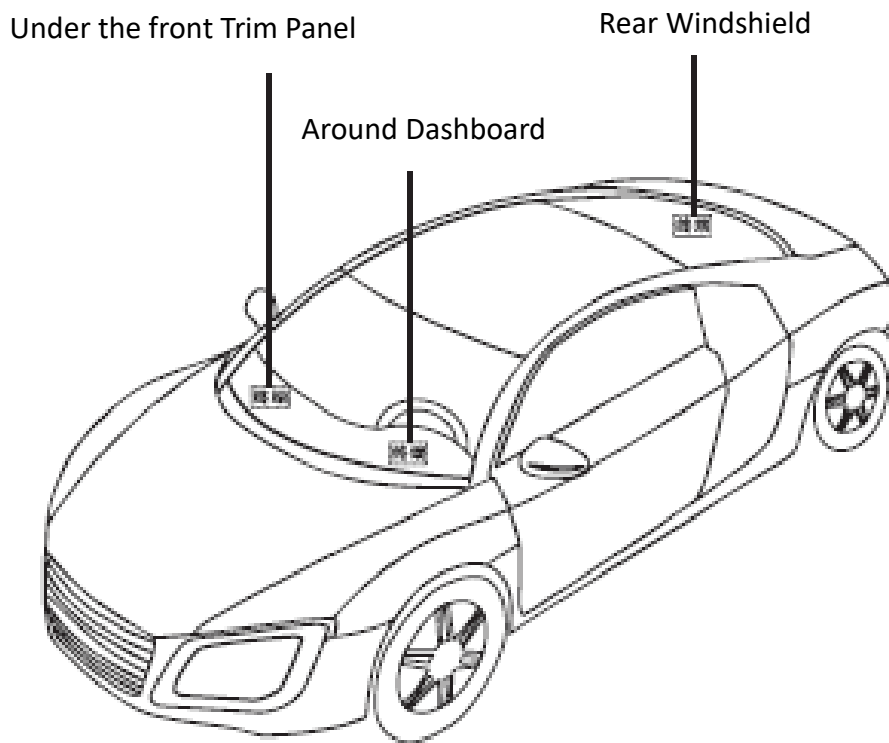

Note: The device should be installed face up to the sky. If the windshield is pasted with a metal thermal insulation layer or a heating layer, it will reduce the signal strength of the satellite, which may make it difficult to locate the satellite. Please change the installation location.

Part V - Platform Operation

5.1 Register & Login into Platform

Login Lncoon platform(us.lncoon.com) with your account and password and check whether the location is correct on it. If not, please take your device to OPEN SKY for better signal intensity.



Real-time
Tracking



GEO
Fence



Track
Playback



Overspeed
Alert



Navigat-
ion



3D Street
View

5.1 Bundle Device with Platform



Attention: If the activation is not successful, please check if you have successfully subscribed to the plan, or check if the power switch is turned on.

Part VI - Troubleshooting

Problem	Solution
Unable to add device	Check your IMEI number
	Check your account region
The device is offline on the platform	Check the external power cable.
	Check your subscription status
	Try find better cellular signals
Unable to Locate	Go to open sky area and try again
	Try find better cellular signals
Location Drifts	Check that the cables are well connected
	Go to the open area and try again
Not responding to commands	Check command format
	Check if the device is online
	Check if parameters are within limits

Caution:

Intended for sale and application in a business environment.

Use the Product in the environment with the temperature Between -20°C and 35°C;
Otherwise, it may damage your product. Products can only be used below 2000m
altitude

For the following equipment:

Product Name: GNSS Vehicle Terminal

Brand Name: JIMI

Model No.: JM-C21

Shenzhen Jimi IOT Co., Ltd

E-mail: xieyi@jimilab.com

hereby declares that this [Name: GNSS Vehicle Terminal, Model: JM-C21] is in
compliance with the essential requirements and other relevant provisions of
Directive 2014/53/EU.



This product is intended for sale and application in a business environment.

RED Article 10 2

-This product can be used across EU member states

RED Article 10 10

-The product is class 1 product, No restrictions

The RF distance between body and product is 20cm

2G

Frequency Range: GPRS900: Tx: 880-915MHz, Rx: 925-960MHz

RF Output Power: GPRS900: 31.96dBm, GPRS1800: 29.08dBm

GPS

Frequency Range: 1575.42MHz Receiving

FCC Radiation Exposure Statement:

This equipment complies with FCC radiation exposure limits set forth for an uncontrolled environment. This equipment should be installed and operated with minimum distance 20cm between the radiator & your body.

FCC Warning

This device complies with Part 15 of the FCC Rules. Operation is subject to the following two conditions:

(1) This device may not cause harmful interference, and (2) this device must accept any interference received, including interference that may cause undesired operation.

Note: This equipment has been tested and found to comply with the limits for a Class B digital device, pursuant to part 15 of the FCC Rules. These limits are designed to provide reasonable protection against harmful interference in a residential installation. This equipment generates, uses and can radiate radio frequency energy and, if not installed and used in accordance with the instructions, may cause harmful interference to radio communications. However, there is no guarantee that interference will not occur in a particular installation. If this equipment does cause harmful interference to radio or television reception, which can be determined by turning the equipment off and on, the user is encouraged to try to correct the interference by one or more of the following measures:

- Reorient or relocate the receiving antenna.
- Increase the separation between the equipment and receiver.
- Connect the equipment into an outlet on a circuit different from that to which the receiver is connected.
- Consult the dealer or an experienced radio/TV technician for help.

NOTE 2: Any changes or modifications to this unit not expressly approved by the party responsible for compliance could void the user's authority to operate the equipment.