

# FCC RADIO TEST REPORT

## FCC ID: 2AML4-CAMIND2K

**Product :** 2K HD WiFi Camera

**Trade Name :** N/A

**Model Name :** MOCAMIND2K-01

**Serial Model :** N/A

**Report No. :** UNIA20042213FR-01

### Prepared for

Apollo Tech USA Inc.

Tech USA Inc. 8608 Utica Ave #220, Rancho Cucamonga, California,  
United States

### Prepared by

Shenzhen United Testing Technology Co., Ltd.

2F, Annex Bldg, Jiahuangyuan Tech Park, #365 Baotian 1 Rd, Tiegang  
Community, Xixiang Str, Bao'an District, Shenzhen, China

## TEST RESULT CERTIFICATION

**Applicant's name**..... : Apollo Tech USA Inc.  
**Address**..... : Tech USA Inc. 8608 Utica Ave #220, Rancho Cucamonga,  
California, United States  
**Manufacture's Name**..... : Apollo Tech USA Inc.  
**Address**..... : Tech USA Inc. 8608 Utica Ave #220, Rancho Cucamonga,  
California, United States

### Product description

**Product name**..... : 2K HD WiFi Camera  
**Trade Mark**..... : N/A  
**Model and/or type reference** .. : MOCAMIND2K-01  
**Standards**..... : FCC Rules and Regulations Part 15 Subpart C Section 15.247  
ANSI C63.10: 2013

This device described above has been tested by Shenzhen United Testing Technology Co., Ltd., and the test results show that the equipment under test (EUT) is in compliance with the FCC requirements. And it is applicable only to the tested sample identified in the report.

This report shall not be reproduced except in full, without the written approval of UNI, this document may be altered or revised by Shenzhen United Testing Technology Co., Ltd., personnel only, and shall be noted in the revision of the document.

**Date of Test**..... :  
**Date (s) of performance of tests**..... : Apr. 10 ~ 22, 2020  
**Date of Issue**..... : Apr. 23, 2020  
**Test Result**..... : Pass

Tested by:

Kahn yang/Engineer

Reviewer:

Sherwin Qian/Supervisor

Approved & Authorized Signer:

Liuze/Manager

Table of Contents

Page

1. TEST SUMMARY.....	5
2. GENERAL INFORMATION.....	6
2.1 GENERAL DESCRIPTION OF EUT.....	6
2.2 Carrier Frequency of Channels.....	7
2.3 Operation of EUT during testing.....	7
2.4 DESCRIPTION OF TEST SETUP.....	7
2.5 MEASUREMENT INSTRUMENTS LIST.....	8
3. CONDUCTED EMISSIONS TEST.....	9
3.1 Conducted Power Line Emission Limit.....	9
3.2 Test Setup.....	9
3.3 Test Procedure.....	9
3.4 Test Result.....	9
4. RADIATED EMISSION TEST.....	12
4.1 Radiation Limit.....	12
4.2 Test Setup.....	12
4.3 Test Procedure.....	13
4.4 Test Result.....	13
5. BAND EDGE.....	28
5.1 Limits.....	28
5.2 Test Procedure.....	28
5.3 Test Result.....	28
6. OCCUPIED BANDWIDTH MEASUREMENT.....	31
6.1 Test Limit.....	31
6.2 Test Procedure.....	31
6.3 Measurement Equipment Used.....	31
6.4 Test Result.....	31
7. POWER SPECTRAL DENSITY TEST.....	38
7.1 Test Limit.....	38
7.2 Test Procedure.....	38
7.3 Measurement Equipment Used.....	38
7.4 Test Result.....	38
8. PEAK OUTPUT POWER TEST.....	45
8.1 Test Limit.....	45
8.2 Test Procedure.....	45

Table of Contents	Page
8.3 Measurement Equipment Used.....	45
8.4 Test Result.....	45
9. OUT OF BAND EMISSIONS TEST.....	46
9.1 Test Limit.....	46
9.2 Test Procedure.....	46
9.3 Test Setup.....	46
9.4 Test Result.....	46
10. SPURIOUS RF CONDUCTED EMISSION.....	49
10.1 Test Limit.....	49
10.2 Test Procedure.....	49
10.3 Test Setup.....	49
10.4 Test Result.....	49
11. ANTENNA REQUIREMENT.....	53
12.PHOTOGRAPH OF TEST.....	54

## 1. TEST SUMMARY

### TEST PROCEDURES AND RESULTS

DESCRIPTION OF TEST	RESULT
CONDUCTED EMISSIONS TEST	COMPLIANT
RADIATED EMISSION TEST	COMPLIANT
BAND EDGE	COMPLIANT
OCCUPIED BANDWIDTH MEASUREMENT	COMPLIANT
POWER SPECTRAL DENSITY	COMPLIANT
PEAK OUTPUT POWER	COMPLIANT
OUT OF BAND EMISSIONS	COMPLIANT
ANTENNA REQUIREMENT	COMPLIANT

### 1.1 TEST FACILITY

Test Firm : Shenzhen United Testing Technology Co., Ltd.  
 Address : 2F, Annex Bldg, Jiahuangyuan Tech Park, #365 Baotian 1 Rd, Tiegang Community, Xixiang Str, Bao'an District, Shenzhen, China

The testing quality ability of our laboratory meet with "Quality Law of People's Republic of China" Clause 19. The testing quality system of our laboratory meets with ISO/IEC-17025 requirements, which is approved by CNAS. This approval result is accepted by MRA of APLAC.

Our test facility is recognized, certified, or accredited by the following organizations:

CNAS-LAB Code: L6494

The EMC Laboratory has been assessed and in compliance with CNAS-CL01 accreditation criteria for testing Laboratories (identical to ISO/IEC 17025:2017 General Requirements) for the Competence of testing Laboratories.

Designation Number: CN1227

Test Firm Registration Number: 674885

The EMC Laboratory has been registered and fully described in a report filed with the (FCC) Federal Communications commission. The acceptance letter from the FCC is maintained in our files.

### 1.2 MEASUREMENT UNCERTAINTY

Measurement Uncertainty	
Conducted Emission Expanded Uncertainty	= 2.23dB, k=2
Radiated emission expanded uncertainty(9kHz-30MHz)	= 3.08dB, k=2
Radiated emission expanded uncertainty(30MHz-1000MHz)	= 4.42dB, k=2
Radiated emission expanded uncertainty(Above 1GHz)	= 4.06dB, k=2

## 2. GENERAL INFORMATION

### 2.1 GENERAL DESCRIPTION OF EUT

Equipment	2K HD WiFi Camera
Trade Mark	N/A
Model Name	MOCAMIND2K-01
Sample ID	UNIA20012213FR-1#
Serial No.	N/A
Model Difference	N/A
FCC ID	2AML4-CAMIND2K
Antenna Type	Internal Antenna
Antenna Gain	2.08dBi
Frequency Range	802.11b/g/n20: 2412~2462 MHz 802.11n40:2422-2452 MHz
Number of Channels	802.11b/g/n20: 11CH 802.11n40:7CH
Modulation Type	DSSS, OFDM
Power Source	DC 5V/1A from Adapter
Adapter	
Manufacturer	SHENZHEN TIANYIN ELECTRONICS CO LTD
M/N	TPA-46B050100UU
Input	100-240V~ 50/60Hz 0.2A
Output	DC 5V/1000mA

### 2.2 Carrier Frequency of Channels

Channel List for 802.11b/g/n(20MHz/40MHz)							
Channel	Frequency (MHz)	Channel	Frequency (MHz)	Channel	Frequency (MHz)	Channel	Frequency (MHz)
01	2412	04	2427	07	2442	10	2457
02	2417	05	2432	08	2447	11	2462
03	2422	06	2437	09	2452		

### 2.3 Operation of EUT during testing

#### Operating Mode

The mode is used: Transmitting mode for 802.11b/g/n (20MHz)/ n(40MHz)

Low Channel: 2412MHz/2422MHz

Middle Channel: 2437MHz

High Channel: 2462MHz/2452MHz

Test SW Version:Realtek MPtool

### 2.4 DESCRIPTION OF TEST SETUP

Operation of EUT during Conducted testing:

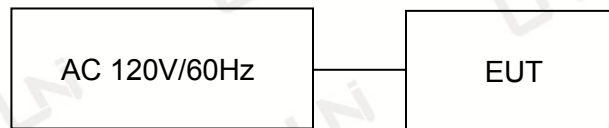

Operation of EUT during Radiation testing:

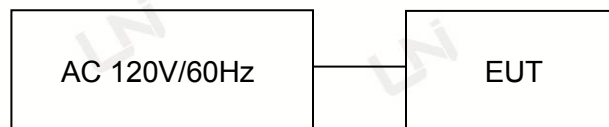

Table for auxiliary equipment:

Equipment Description	Manufacturer	Model	Calibration Due Date
N/A	N/A	N/A	N/A

2.5 MEASUREMENT INSTRUMENTS LIST

Item	Equipment	Manufacturer	Model No.	Serial No.	Calibrated until
<b>CONDUCTED EMISSIONS TEST</b>					
1	AMN	Schwarzbeck	NNLK8121	8121370	2020.9.6
2	AMN	ETS	3810/2	00020199	2020.9.6
3	EMI TEST RECEIVER	Rohde&Schwarz	ESCI	101210	2020.9.6
4	AAN	TESEQ	T8-Cat6	38888	2020.9.6
<b>RADIATED EMISSION TEST</b>					
1	Horn Antenna	Sunol	DRH-118	A101415	2020.9.6
2	BicoNILog Antenna	Sunol	JB1 Antenna	A090215	2020.9.6
3	PREAMP	HP	8449B	3008A00160	2020.9.6
4	PREAMP	HP	8447D	2944A07999	2020.9.6
5	EMI TEST RECEIVER	Rohde&Schwarz	ESR3	101891	2020.9.6
6	VECTOR Signal Generator	Rohde&Schwarz	SMU200A	101521	2020.9.6
7	Signal Generator	Agilent	E4421B	MY4335105	2020.9.6
8	MXA Signal Analyzer	Agilent	N9020A	MY50510140	2020.9.6
9	MXA Signal Analyzer	Agilent	N9020A	MY51110104	2020.9.6
10	ANT Tower&Turn table Controller	Champro	EM 1000	60764	2020.9.6
11	Anechoic Chamber	Taihe Maorui	9m*6m*6m	966A0001	2020.9.6
12	Shielding Room	Taihe Maorui	6.4m*4m*3m	643A0001	2020.9.6
13	RF Power sensor	DARE	RPR3006W	15I00041SNO88	2020.9.6
14	RF Power sensor	DARE	RPR3006W	15I00041SNO89	2020.9.6
15	RF power divider	Anritsu	K241B	992289	2020.9.6
16	Wideband radio communication tester	Rohde&Schwarz	CMW500	154987	2020.9.6
17	Biconical antenna	Schwarzbeck	VHA 9103	91032360	2020.9.6
18	Biconical antenna	Schwarzbeck	VHA 9103	91032361	2020.9.6
19	Broadband Hybrid Antennas	Schwarzbeck	VULB9163	VULB9163#958	2020.9.6
20	Horn Antenna	Schwarzbeck	BBHA9120D	9120D-1680	2020.9.6
21	Active Receive Loop Antenna	Schwarzbeck	FMZB 1919B	00023	2020.9.6
22	Horn Antenna	Schwarzbeck	BBHA 9170	BBHA9170651	2020.9.6
23	Microwave Broadband Pre-amplifier	Schwarzbeck	BBV 9721	100472	2020.9.6
24	Active Loop Antenna	Com-Power	AL-130R	10160009	2020.9.6
25	Power Meter	KEYSIGHT	N1911A	MY50520168	2020.9.6
26	Frequency Meter	VICTOR	VC2000	997406086	2020.9.6
27	DC Power Source	HYELEC	HY5020E	055161818	2020.9.6
<b>Test software</b>					
1	E3	Audix	6.101223a	N/A	N/A



### 3. CONDUCTED EMISSIONS TEST

#### 3.1 Conducted Power Line Emission Limit

For unintentional device, according to § 15.107(a) Line Conducted Emission Limits is as following

Frequency (MHz)	Maximum RF Line Voltage(dB $\mu$ V)			
	CLASS A		CLASS B	
	Q.P.	Ave.	Q.P.	Ave.
0.15~0.50	79	66	66~56*	56~46*
0.50~5.00	73	60	56	46
5.00~30.0	73	60	60	50

\* Decreasing linearly with the logarithm of the frequency

For intentional device, according to §15.207(a) Line Conducted Emission Limit is same as above table.

#### 3.2 Test Setup

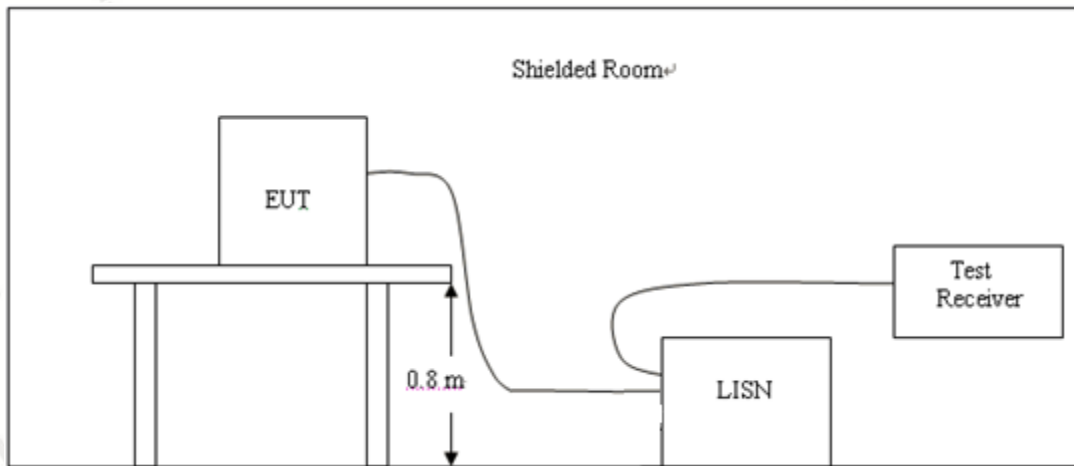

#### 3.3 Test Procedure

- 1, The equipment was set up as per the test configuration to simulate typical actual usage per the user's manual. A wooden table with a height of 0.8 meters is used and is placed on the ground plane as per ANSI C63.10.
- 2, Support equipment, if needed, was placed as per ANSI C63.10.
- 3, All I/O cables were positioned to simulate typical actual usage as per ANSI C63.10.
- 4, If a EUT received DC power from the USB Port of Notebook PC, the PC's adapter received AC120V/60Hz power through a Line Impedance Stabilization Network (LISN) which supplied power source and was grounded to the ground plane.
- 5, All support equipments received AC power from a second LISN, if any.
- 6, The EUT test program was started. Emissions were measured on each current carrying line of the EUT using a spectrum Analyzer / Receiver connected to the LISN powering the EUT. The LISN has two monitoring points: Line 1 (Hot Side) and Line 2 (Neutral Side). Two scans were taken: one with Line 1 connected to Analyzer / Receiver and Line 2 connected to a 50 ohm load; the second scan had Line 1 connected to a 50 ohm load and Line 2 connected to the Analyzer / Receiver.
- 7, Analyzer / Receiver scanned from 150 KHz to 30MHz for emissions in each of the test modes.

#### 3.4 Test Result

Pass

Remark:

1. All modes were tested at AC 120V and 240V, only the worst result of AC 120V was reported.
2. All modes were tested at Low, Middle, and High channel, only the worst result of 802.11b Low Channel was reported as below:

Temperature:	24°C	Relative Humidity:	48%
Test Date:	Apr. 15, 2020	Pressure:	1010hPa
Test Voltage:	120V/60Hz	Phase:	Line
Test Mode:	Transmitting mode of 802.11b 2412MHz		

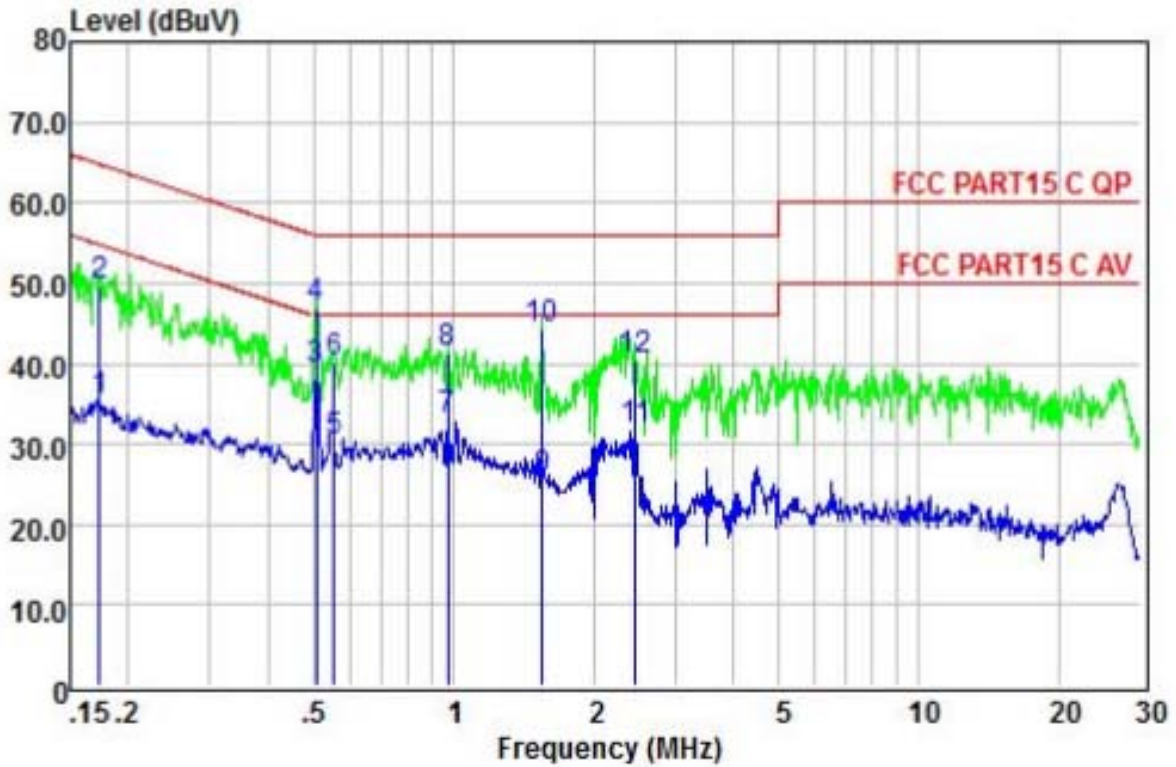

	Read Freq	Read Level	LISN Factor	Result Level	Limit Line	Over Limit	Remark
	MHz	dBuV	dB	dBuV	dBuV	dB	
1	0.17	25.85	9.63	35.48	54.81	-19.33	Average
2	0.17	40.17	9.63	49.80	64.81	-15.01	QP
3	0.51	29.55	9.69	39.24	46.00	-6.76	Average
4	0.51	37.21	9.69	46.90	56.00	-9.10	QP
5	0.56	20.61	9.67	30.28	46.00	-15.72	Average
6	0.56	30.55	9.67	40.22	56.00	-15.78	QP
7	0.97	23.39	9.61	33.00	46.00	-13.00	Average
8	0.97	31.75	9.61	41.36	56.00	-14.64	QP
9	1.55	15.89	9.60	25.49	46.00	-20.51	Average
10	1.55	34.76	9.60	44.36	56.00	-11.64	QP
11	2.46	22.27	9.58	31.85	46.00	-14.15	Average
12	2.46	30.92	9.58	40.50	56.00	-15.50	QP

Remark: Factor = Insertion Loss + Cable Loss, Result = Reading + Factor, Margin = Result – Limit.

Temperature:	24°C	Relative Humidity:	48%
Test Date:	Apr. 15, 2020	Pressure:	1010hPa
Test Voltage:	120V/60Hz	Phase:	Neutral
Test Mode:	Transmitting mode of 802.11b 2412MHz		

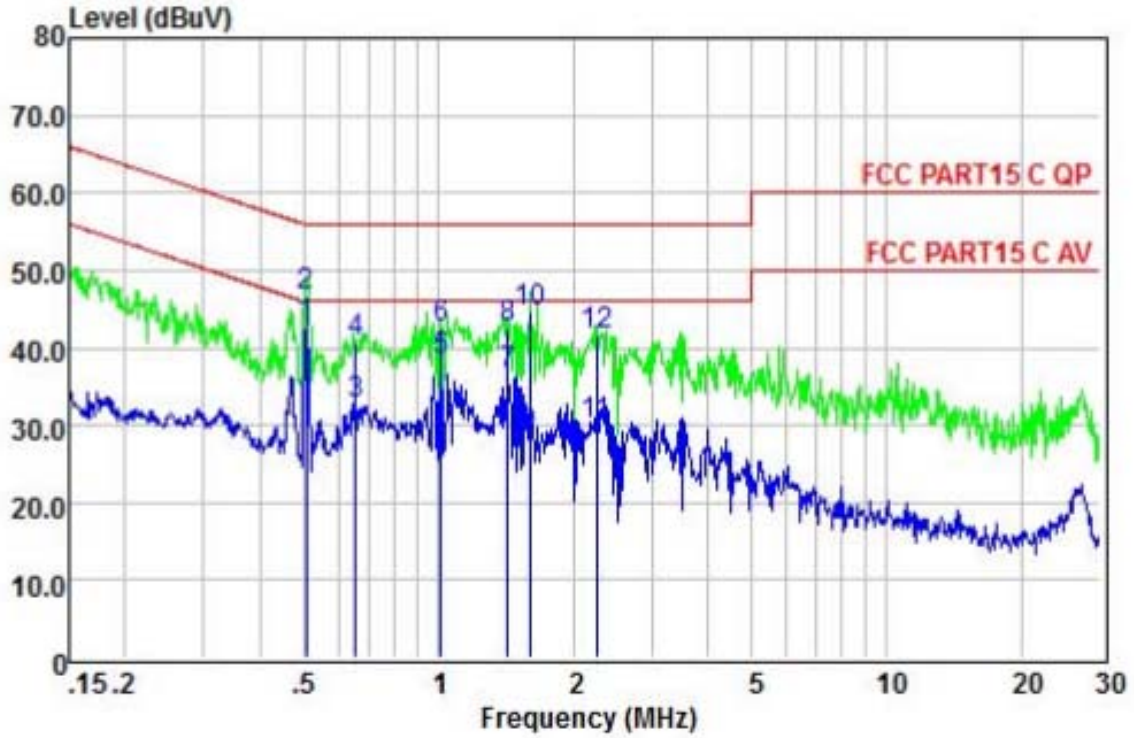

	Read Freq	Read Level	LISN Factor	Level	Limit Line	Over Limit	Remark
	MHz	dBuV	dB	dBuV	dBuV	dB	
1	0.51	33.26	9.63	42.89	46.00	-3.11	Average
2	0.51	37.17	9.63	46.80	56.00	-9.20	QP
3	0.65	23.21	9.63	32.84	46.00	-13.16	Average
4	0.65	31.26	9.63	40.89	56.00	-15.11	QP
5	1.02	28.74	9.63	38.37	46.00	-7.63	Average
6	1.02	32.87	9.63	42.50	56.00	-13.50	QP
7	1.43	26.90	9.60	36.50	46.00	-9.50	Average
8	1.43	32.90	9.60	42.50	56.00	-13.50	QP
9	1.60	18.98	9.59	28.57	46.00	-17.43	Average
10	1.60	35.03	9.59	44.62	56.00	-11.38	QP
11	2.26	20.41	9.59	30.00	46.00	-16.00	Average
12	2.26	31.94	9.59	41.53	56.00	-14.47	QP

Remark: Factor = Insertion Loss + Cable Loss, Result = Reading + Factor, Margin = Result – Limit.

## 4. RADIATED EMISSION TEST

### 4.1 Radiation Limit

For unintentional device, according to § 15.109(a), except for Class A digital devices, the field strength of radiated emissions from unintentional radiators at a distance of 3 meters shall not exceed the following values:

Frequency (MHz)	Distance (Meters)	Radiated (dB $\mu$ V/m)	Radiated ( $\mu$ V/m)
30-88	3	40	100
88-216	3	43.5	150
216-960	3	46	200
Above 960	3	54	500

For intentional device, according to § 15.209(a), the general requirement of field strength of radiated emissions from intentional radiators at a distance of 3 meters shall not exceed the above table.

### 4.2 Test Setup

#### 1. Radiated Emission Test-Up Frequency Below 30MHz

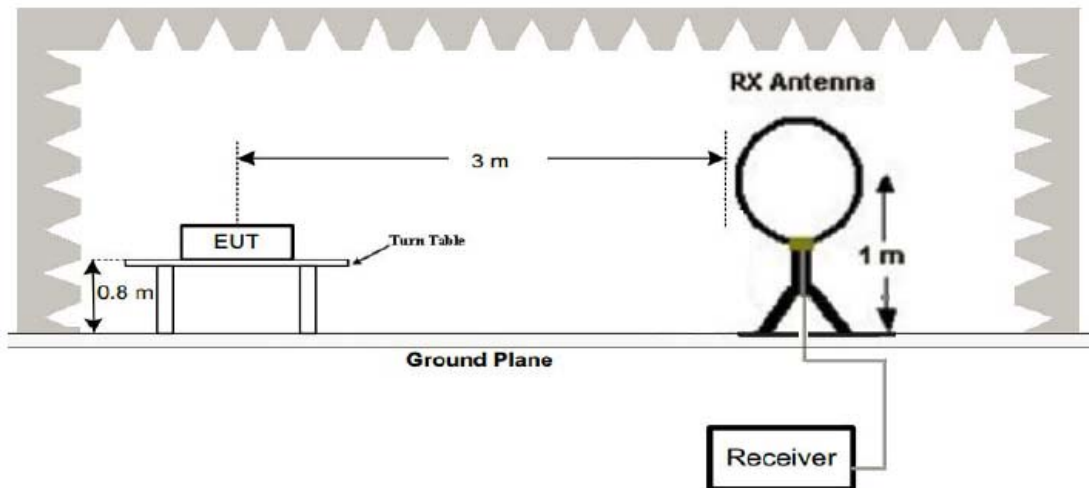

#### 2. Radiated Emission Test-Up Frequency 30MHz~1GHz

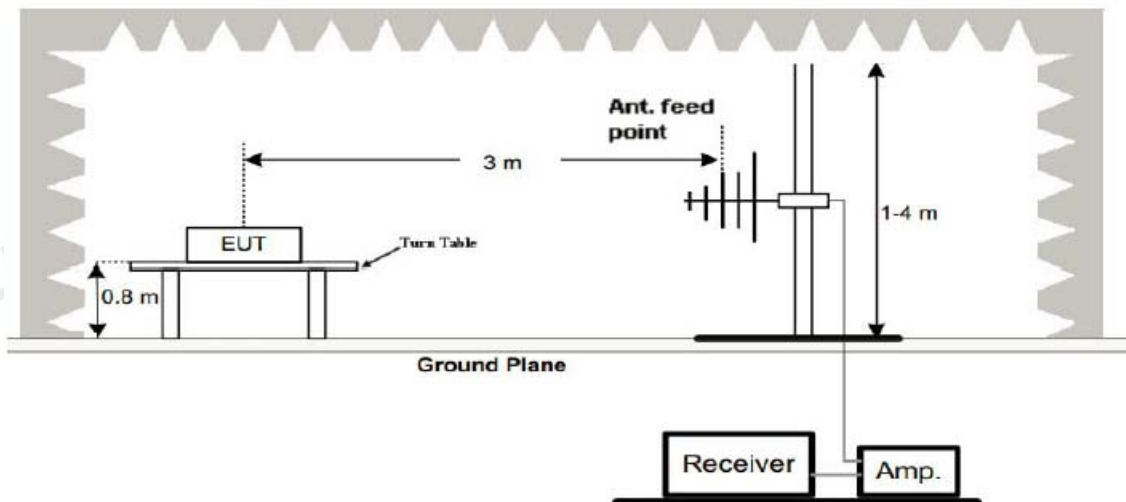

### 3. Radiated Emission Test-Up Frequency Above 1GHz

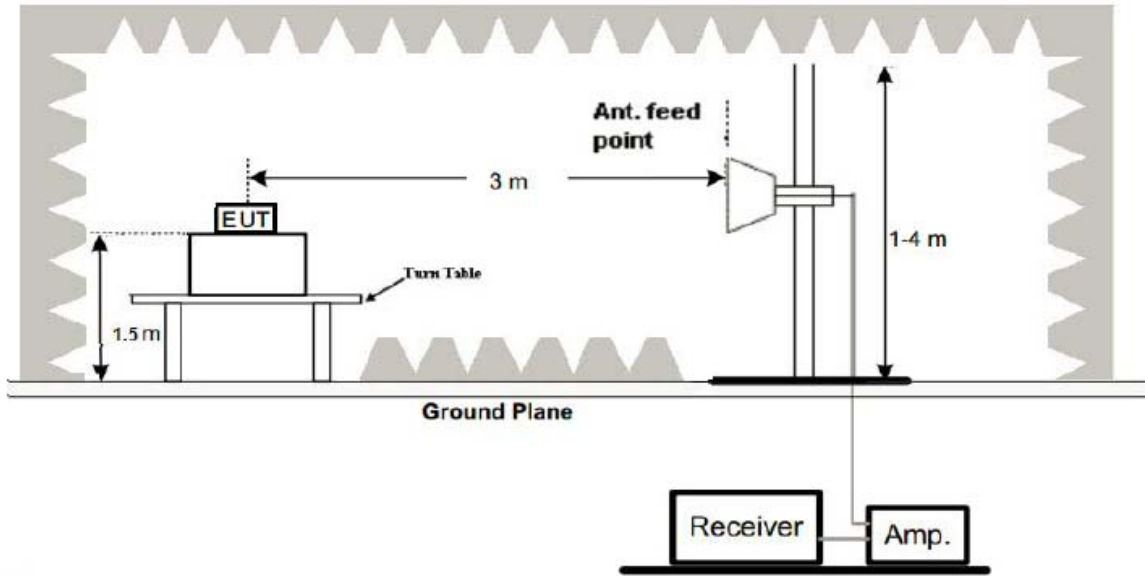

#### 4.3 Test Procedure

1. Below 1GHz measurement the EUT is placed on turntable which is 0.8m above ground plane. And above 1GHz measurement EUT was placed on low permittivity and low tangent turn table which is 1.5m above ground plane.
2. The turntable shall be rotated for 360 degrees to determine the position of maximum emission level.
3. EUT is set 3m away from the receiving antenna, which is varied from 1m to 4m to find out the highest emissions.
4. Maximum procedure was performed on the six highest emissions to ensure EUT compliance.
5. And also, each emission was to be maximized by changing the polarization of receiving antenna both horizontal and vertical.
6. Repeat above procedures until the measurements for all frequencies are complete.
7. The test frequency range from 9KHz to 25GHz per FCC PART 15.33(a).
8. The distance between test antenna and EUT as following table states:

Test Frequency range	Test Antenna Type	Test Distance
9KHz-30MHz	Active Loop Antenna	3
30MHz-1GHz	Bilog Antenna	3
1GHz-18GHz	Horn Antenna	3
18GHz-25GHz	Horn Antenna	1

**Note:**

For battery operated equipment, the equipment tests shall be performed using a new battery.

#### 4.4 Test Result

**PASS**

Remark:

1. All modes of 802.11b/g/n20 were test at Low, Middle, and High channel, only the worst result of 802.11b Low Channel was reported for below 1GHz test.
2. By preliminary testing and verifying three axis (X, Y and Z) position of EUT transmitted status, it was found that "Z axis" position was the worst, and test data recorded in this report.

Below 1GHz Test Results:

Temperature:	22°C	Relative Humidity:	48%
Test Date:	Apr. 15, 2020	Pressure:	1010hPa
Test Voltage:	120V/60Hz	Polarization:	Horizontal
Test Mode:	Transmitting mode of 802.11b 2412MHz		

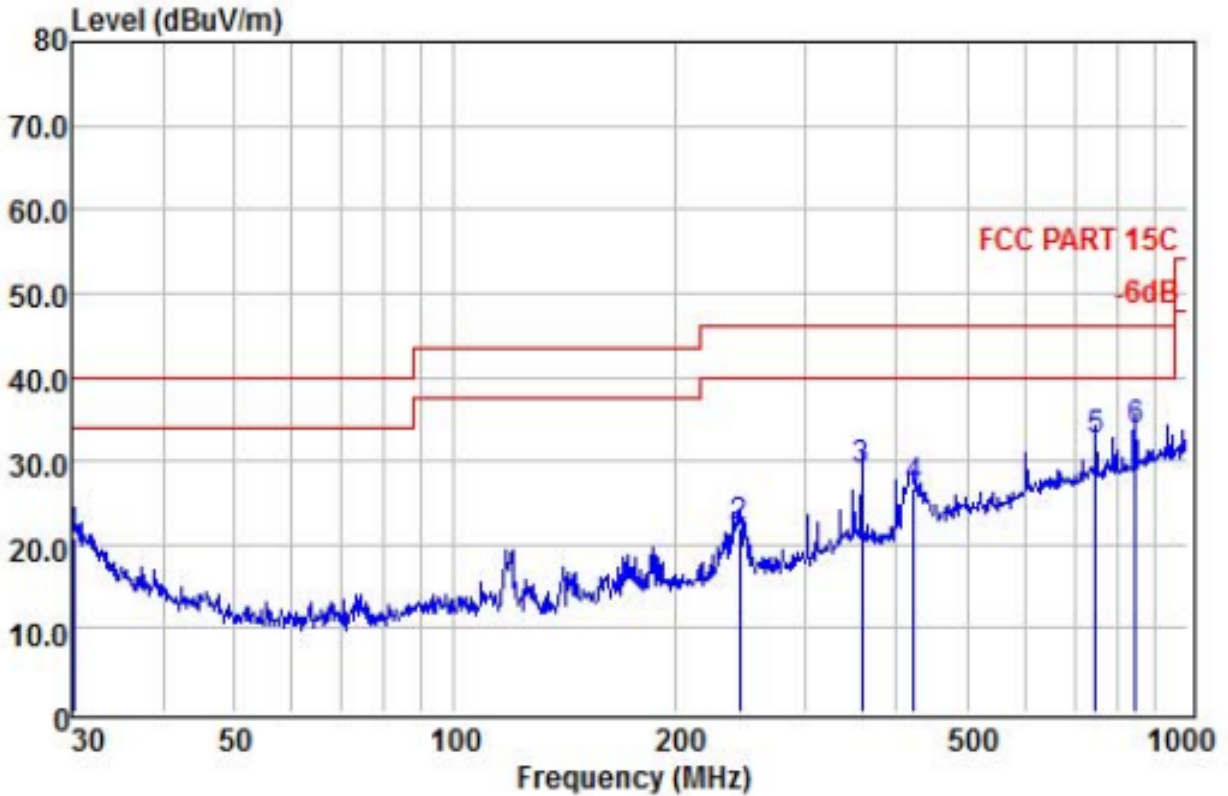

	Read	Antenna	Cable	Limit	Over		
Freq	Level	Factor	Loss	Line	Limit	Remark	
MHz	dBuV	dB/m	dB	dBuV/m	dBuV/m	dB	
1	30.21	1.61	18.80	0.34	20.75	40.00	-19.25 QP
2	245.09	8.74	12.90	0.40	22.04	46.00	-23.96 QP
3	360.45	11.97	16.12	0.81	28.90	46.00	-17.10 QP
4	423.54	8.84	16.90	0.98	26.72	46.00	-19.28 QP
5	750.11	8.17	22.80	1.31	32.28	46.00	-13.72 QP
6	851.04	9.07	23.10	1.52	33.69	46.00	-12.31 QP

Remark: Absolute Level = Reading Level + Factor, Margin = Absolute Level – Limit  
 Factor = Ant. Factor + Cable Loss – Pre-amplifier

Temperature:	22°C	Relative Humidity:	48%
Test Date:	Apr. 15, 2020	Pressure:	1010hPa
Test Voltage:	120V/60Hz	Polarization:	Vertical
Test Mode:	Transmitting mode of 802.11b 2412MHz		

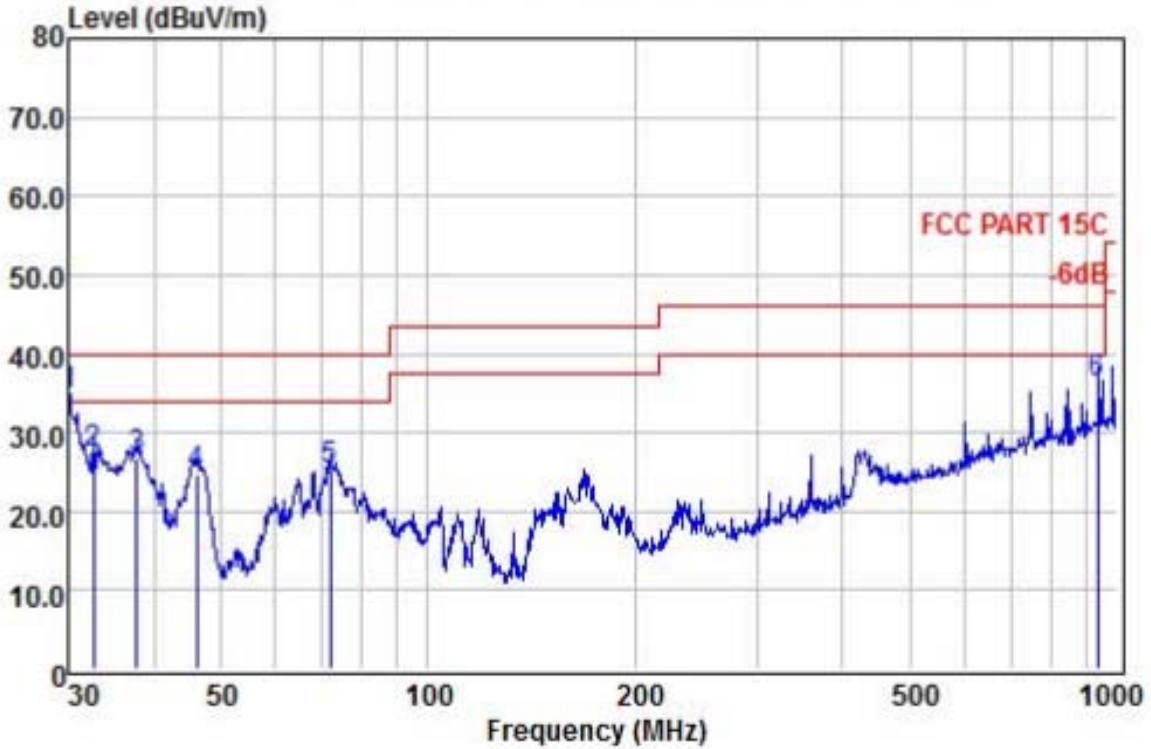

	ReadAntenna	Cable	Limit	Over				
Freq	Level	Factor	Line	Limit	Remark			
MHz	dBuV	dB/m	dBuV/m	dB				
1 !	30.00	15.56	18.80	0.34	34.70	40.00	-5.30	QP
2	32.63	9.85	17.25	0.28	27.38	40.00	-12.62	QP
3	37.68	12.36	14.27	0.17	26.80	40.00	-13.20	QP
4	46.18	14.31	10.37	0.12	24.80	40.00	-15.20	QP
5	72.08	17.50	7.60	0.14	25.24	40.00	-14.76	QP
6	938.83	10.06	24.64	1.65	36.35	46.00	-9.65	QP

Remark: Absolute Level = Reading Level + Factor, Margin = Absolute Level – Limit  
 Factor = Ant. Factor + Cable Loss – Pre-amplifier

Remark:

- (1) Measuring frequencies from 9 KHz to the 1 GHz, Radiated emission test from 9KHz to 30MHz was verified, and no any emission was found except system noise floor.
- (2) \* denotes emission frequency which appearing within the Restricted Bands specified in provision of 15.205, then the general radiated emission limits in 15.209 apply.
- (3) The IF bandwidth of EMI Test Receiver between 30MHz to 1GHz was 120KHz, 1 MHz for measuring above 1 GHz, below 30MHz was 10KHz.

Above 1 GHz Test Results:

CH Low of 802.11b Mode (2412MHz)

Horizontal:

Frequency (MHz)	Reading Result (dBμV)	Factor (dB)	Emission Level (dBμV/m)	Limits (dBμV/m)	Margin (dB)	Detector Type
4824	64.35	-3.64	60.71	74	-13.29	PK
4824	50.33	-3.64	46.69	54	-7.31	AV
7236	60.27	-0.95	59.32	74	-14.68	PK
7236	45.38	-0.95	44.43	54	-9.57	AV

Remark: Factor = Antenna Factor + Cable Loss – Pre-amplifier. Margin = Absolute Level – Limit

Vertical:

Frequency (MHz)	Reading Result (dBμV)	Factor (dB)	Emission Level (dBμV/m)	Limits (dBμV/m)	Margin (dB)	Detector Type
4824	63.47	-3.64	59.83	74	-14.17	PK
4824	49.28	-3.64	45.64	54	-8.36	AV
7236	60.27	-0.95	59.32	74	-14.68	PK
7236	45.28	-0.95	44.33	54	-9.67	AV

Remark: Factor = Antenna Factor + Cable Loss – Pre-amplifier. Margin = Absolute Level – Limit



CH Middle of 802.11b Mode (2437MHz)

Horizontal:

Frequency (MHz)	Reading Result (dBμV)	Factor (dB)	Emission Level (dBμV/m)	Limits (dBμV/m)	Margin (dB)	Detector Type
4874	62.33	-3.51	58.82	74	-15.18	PK
4874	48.29	-3.51	44.78	54	-9.22	AV
7311	63.57	-0.82	62.75	74	-11.25	PK
7311	48.29	-0.82	47.47	54	-6.53	AV

Remark: Factor = Antenna Factor + Cable Loss – Pre-amplifier. Margin = Absolute Level – Limit

Vertical:

Frequency (MHz)	Reading Result (dBμV)	Factor (dB)	Emission Level (dBμV/m)	Limits (dBμV/m)	Margin (dB)	Detector Type
4874	62.33	-3.51	58.82	74	-15.18	PK
4874	51.28	-3.51	47.77	54	-6.23	AV
7311	53.47	-0.82	52.65	74	-21.35	PK
7311	48.53	-0.82	47.71	54	-6.29	AV

Remark: Factor = Antenna Factor + Cable Loss – Pre-amplifier. Margin = Absolute Level – Limit

CH High of 802.11b Mode (2462MHz)

Horizontal:

Frequency (MHz)	Reading Result (dBμV)	Factor (dB)	Emission Level (dBμV/m)	Limits (dBμV/m)	Margin (dB)	Detector Type
4924	62.55	-3.43	59.12	74	-14.88	PK
4924	50.27	-3.43	46.84	54	-7.16	AV
7386	55.69	-0.75	54.94	74	-19.06	PK
7386	45.39	-0.75	44.64	54	-9.36	AV

Remark: Factor = Antenna Factor + Cable Loss – Pre-amplifier. Margin = Absolute Level – Limit

Vertical:

Frequency (MHz)	Reading Result (dBμV)	Factor (dB)	Emission Level (dBμV/m)	Limits (dBμV/m)	Margin (dB)	Detector Type
4924	59.68	-3.43	56.25	74	-17.75	PK
4924	46.38	-3.43	42.95	54	-11.05	AV
7386	57.22	-0.75	56.47	74	-17.53	PK
7386	43.69	-0.75	42.94	54	-11.06	AV

Remark: Factor = Antenna Factor + Cable Loss – Pre-amplifier. Margin = Absolute Level – Limit

Remark :

- (1) Measuring frequencies from 1 GHz to the 25 GHz.
- (2) "F" denotes fundamental frequency; "H" denotes spurious frequency. "E" denotes band edge frequency.
- (3) \* denotes emission frequency which appearing within the Restricted Bands specified in provision of 15.205, then the general radiated emission limits in 15.209 apply.
- (4) Data of measurement within this frequency range shown "---" in the table above means the reading of emissions are attenuated more than 20dB below the permissible limits or the field strength is too small to be measured.
- (5) The IF bandwidth of EMI Test Receiver between 30MHz to 1GHz was 120KHz, 1 MHz for measuring above 1 GHz, below 30MHz was 10KHz. The resolution bandwidth of test receiver/spectrum analyzer is 1MHz and video bandwidth is 3MHz for peak measurement with peak detector at frequency above 1GHz. The resolution bandwidth of test receiver/spectrum analyzer is 1MHz and video bandwidth is 10Hz for Average measurement with peak detection at frequency above 1GHz.
- (6) When the test results of Peak Detected below the limits of Average Detected, the Average Detected is not need completed. For example: Top Channel at Fundamental 73.16dBuV/m(PK Value) <93.98(AV Limit), at harmonic 53.20 dBuV/m(PK Value) <54 dBuV/m(AV Limit), the Average Detected not need to completed.

CH Low of 802.11g Mode (2412MHz)

Horizontal:

Frequency (MHz)	Reading Result (dBμV)	Factor (dB)	Emission Level (dBμV/m)	Limits (dBμV/m)	Margin (dB)	Detector Type
4824	62.35	-3.64	58.71	74	-15.29	PK
4824	51.29	-3.64	47.65	54	-6.35	AV
7236	55.13	-0.95	54.18	74	-19.82	PK
7236	47.68	-0.95	46.73	54	-7.27	AV

Remark: Factor = Antenna Factor + Cable Loss – Pre-amplifier. Margin = Absolute Level – Limit

Vertical:

Frequency (MHz)	Reading Result (dBμV)	Factor (dB)	Emission Level (dBμV/m)	Limits (dBμV/m)	Margin (dB)	Detector Type
4824	63.69	-3.64	60.05	74	-13.95	PK
4824	50.29	-3.64	46.65	54	-7.35	AV
7236	58.63	-0.95	57.68	74	-16.32	PK
7236	48.37	-0.95	47.42	54	-6.58	AV

Remark: Factor = Antenna Factor + Cable Loss – Pre-amplifier. Margin = Absolute Level – Limit

CH Middle of 802.11g Mode (2437MHz)

Horizontal:

Frequency (MHz)	Reading Result (dBμV)	Factor (dB)	Emission Level (dBμV/m)	Limits (dBμV/m)	Margin (dB)	Detector Type
4874	62.35	-3.51	58.84	74	-15.16	PK
4874	48.33	-3.51	44.82	54	-9.18	AV
7311	56.39	-0.82	55.57	74	-18.43	PK
7311	47.69	-0.82	46.87	54	-7.13	AV

Remark: Factor = Antenna Factor + Cable Loss – Pre-amplifier. Margin = Absolute Level – Limit

Vertical:

Frequency (MHz)	Reading Result (dBμV)	Factor (dB)	Emission Level (dBμV/m)	Limits (dBμV/m)	Margin (dB)	Detector Type
4874	63.59	-3.51	60.08	74	-13.92	PK
4874	48.63	-3.51	45.12	54	-8.88	AV
7311	54.31	-0.82	53.49	74	-20.51	PK
7311	46.38	-0.82	45.56	54	-8.44	AV

Remark: Factor = Antenna Factor + Cable Loss – Pre-amplifier. Margin = Absolute Level – Limit

CH High of 802.11g Mode (2462MHz)

Horizontal:

Frequency (MHz)	Reading Result (dBμV)	Factor (dB)	Emission Level (dBμV/m)	Limits (dBμV/m)	Margin (dB)	Detector Type
4924	58.39	-3.43	54.96	74	-19.04	PK
4924	47.29	-3.43	43.86	54	-10.14	AV
7386	57.49	-0.75	56.74	74	-17.26	PK
7386	48.93	-0.75	48.18	54	-5.82	AV

Remark: Factor = Antenna Factor + Cable Loss – Pre-amplifier. Margin = Absolute Level – Limit

Vertical:

Frequency (MHz)	Reading Result (dBμV)	Factor (dB)	Emission Level (dBμV/m)	Limits (dBμV/m)	Margin (dB)	Detector Type
4924	64.27	-3.43	60.84	74	-13.16	PK
4924	51.33	-3.43	47.9	54	-6.1	AV
7386	58.37	-0.75	57.62	74	-16.38	PK
7386	47.69	-0.75	46.94	54	-7.06	AV

Remark: Factor = Antenna Factor + Cable Loss – Pre-amplifier. Margin = Absolute Level – Limit

Remark :

- (1) Measuring frequencies from 1 GHz to the 25 GHz.
- (2) "F" denotes fundamental frequency; "H" denotes spurious frequency. "E" denotes band edge frequency.
- (3) \* denotes emission frequency which appearing within the Restricted Bands specified in provision of 15.205, then the general radiated emission limits in 15.209 apply.
- (4) Data of measurement within this frequency range shown "---" in the table above means the reading of emissions are attenuated more than 20dB below the permissible limits or the field strength is too small to be measured.
- (5) The IF bandwidth of EMI Test Receiver between 30MHz to 1GHz was 120KHz, 1 MHz for measuring above 1 GHz, below 30MHz was 10KHz. The resolution bandwidth of test receiver/spectrum analyzer is 1MHz and video bandwidth is 3MHz for peak measurement with peak detector at frequency above 1GHz. The resolution bandwidth of test receiver/spectrum analyzer is 1MHz and video bandwidth is 10Hz for Average measurement with peak detection at frequency above 1GHz.
- (6) When the test results of Peak Detected below the limits of Average Detected, the Average Detected is not need completed. For example: Top Channel at Fundamental 73.16dBuV/m(PK Value) <93.98(AV Limit), at harmonic 53.20 dBuV/m(PK Value) <54 dBuV/m(AV Limit), the Average Detected not need to completed.

CH Low of 802.11n/H20 Mode (2412MHz)

Horizontal:

Frequency (MHz)	Reading Result (dBμV)	Factor (dB)	Emission Level (dBμV/m)	Limits (dBμV/m)	Margin (dB)	Detector Type
4824	63.56	-3.64	59.92	74	-14.08	PK
4824	53.27	-3.64	49.63	54	-4.37	AV
7236	57.29	-0.95	56.34	74	-17.66	PK
7236	48.66	-0.95	47.71	54	-6.29	AV

Remark: Factor = Antenna Factor + Cable Loss – Pre-amplifier. Margin = Absolute Level – Limit

Vertical:

Frequency (MHz)	Reading Result (dBμV)	Factor (dB)	Emission Level (dBμV/m)	Limits (dBμV/m)	Margin (dB)	Detector Type
4824	62.53	-3.64	58.89	74	-15.11	PK
4824	50.27	-3.64	46.63	54	-7.37	AV
7236	55.99	-0.95	55.04	74	-18.96	PK
7236	47.29	-0.95	46.34	54	-7.66	AV

Remark: Factor = Antenna Factor + Cable Loss – Pre-amplifier. Margin = Absolute Level – Limit

CH Middle of 802.11n/H20 Mode (2437MHz)

Horizontal:

Frequency (MHz)	Reading Result (dBμV)	Factor (dB)	Emission Level (dBμV/m)	Limits (dBμV/m)	Margin (dB)	Detector Type
4874	60.53	-3.51	57.02	74	-16.98	PK
4874	48.63	-3.51	45.12	54	-8.88	AV
7311	58.63	-0.82	57.81	74	-16.19	PK
7311	46.39	-0.82	45.57	54	-8.43	AV

Remark: Factor = Antenna Factor + Cable Loss – Pre-amplifier. Margin = Absolute Level – Limit

Vertical:

Frequency (MHz)	Reading Result (dBμV)	Factor (dB)	Emission Level (dBμV/m)	Limits (dBμV/m)	Margin (dB)	Detector Type
4874	60.53	-3.51	57.02	74	-16.98	PK
4874	51.72	-3.51	48.21	54	-5.79	AV
7311	58.96	-0.82	58.14	74	-15.86	PK
7311	48.33	-0.82	47.51	54	-6.49	AV

Remark: Factor = Antenna Factor + Cable Loss – Pre-amplifier. Margin = Absolute Level – Limit

CH High of 802.11n/H20 Mode (2462MHz)

Horizontal:

Frequency (MHz)	Reading Result (dBμV)	Factor (dB)	Emission Level (dBμV/m)	Limits (dBμV/m)	Margin (dB)	Detector Type
4924	63.27	-3.43	59.84	74	-14.16	PK
4924	53.21	-3.43	49.78	54	-4.22	AV
7386	56.29	-0.75	55.54	74	-18.46	PK
7386	49.26	-0.75	48.51	54	-5.49	AV

Remark: Factor = Antenna Factor + Cable Loss – Pre-amplifier. Margin = Absolute Level – Limit

Vertical:

Frequency (MHz)	Reading Result (dBμV)	Factor (dB)	Emission Level (dBμV/m)	Limits (dBμV/m)	Margin (dB)	Detector Type
4924	64.53	-3.43	61.1	74	-12.9	PK
4924	47.59	-3.43	44.16	54	-9.84	AV
7386	55.39	-0.75	54.64	74	-19.36	PK
7386	46.13	-0.75	45.38	54	-8.62	AV

Remark: Factor = Antenna Factor + Cable Loss – Pre-amplifier. Margin = Absolute Level – Limit

Remark :

- (1) Measuring frequencies from 1 GHz to the 25 GHz.
- (2) "F" denotes fundamental frequency; "H" denotes spurious frequency. "E" denotes band edge frequency.
- (3) \* denotes emission frequency which appearing within the Restricted Bands specified in provision of 15.205, then the general radiated emission limits in 15.209 apply.
- (4) Data of measurement within this frequency range shown "---" in the table above means the reading of emissions are attenuated more than 20dB below the permissible limits or the field strength is too small to be measured.
- (5) The IF bandwidth of EMI Test Receiver between 30MHz to 1GHz was 120KHz, 1 MHz for measuring above 1 GHz, below 30MHz was 10KHz. The resolution bandwidth of test receiver/spectrum analyzer is 1MHz and video bandwidth is 3MHz for peak measurement with peak detector at frequency above 1GHz. The resolution bandwidth of test receiver/spectrum analyzer is 1MHz and video bandwidth is 10Hz for Average measurement with peak detection at frequency above 1GHz.
- (6) When the test results of Peak Detected below the limits of Average Detected, the Average Detected is not need completed. For example: Top Channel at Fundamental 73.16dBuV/m(PK Value) <93.98(AV Limit), at harmonic 53.20 dBuV/m(PK Value) <54 dBuV/m(AV Limit), the Average Detected not need to completed.



CH Low of 802.11n/H40 Mode (2422MHz)

Horizontal:

Frequency (MHz)	Reading Result (dB $\mu$ V)	Factor (dB)	Emission Level (dB $\mu$ V/m)	Limits (dB $\mu$ V/m)	Margin (dB)	Detector Type
4844	64.35	-3.64	60.71	74	-13.29	PK
4844	47.59	-3.64	43.95	54	-10.05	AV
7266	56.33	-0.95	55.38	74	-18.62	PK
7266	48.29	-0.95	47.34	54	-6.66	AV

Remark: Factor = Antenna Factor + Cable Loss – Pre-amplifier. Margin = Absolute Level – Limit

Vertical:

Frequency (MHz)	Reading Result (dB $\mu$ V)	Factor (dB)	Emission Level (dB $\mu$ V/m)	Limits (dB $\mu$ V/m)	Margin (dB)	Detector Type
4844	63.59	-3.64	59.95	74	-14.05	PK
4844	50.27	-3.64	46.63	54	-7.37	AV
7266	61.53	-0.95	60.58	74	-13.42	PK
7266	47.29	-0.95	46.34	54	-7.66	AV

Remark: Factor = Antenna Factor + Cable Loss – Pre-amplifier. Margin = Absolute Level – Limit

CH Middle of 802.11n/H40 Mode (2437MHz)

Horizontal:

Frequency (MHz)	Reading Result (dBμV)	Factor (dB)	Emission Level (dBμV/m)	Limits (dBμV/m)	Margin (dB)	Detector Type
4874	63.58	-3.51	60.07	74	-13.93	PK
4874	50.43	-3.51	46.92	54	-7.08	AV
7311	57.82	-0.82	57	74	-17	PK
7311	48.36	-0.82	47.54	54	-6.46	AV

Remark: Factor = Antenna Factor + Cable Loss – Pre-amplifier. Margin = Absolute Level – Limit

Vertical:

Frequency (MHz)	Reading Result (dBμV)	Factor (dB)	Emission Level (dBμV/m)	Limits (dBμV/m)	Margin (dB)	Detector Type
4874	63.53	-3.51	60.02	74	-13.98	PK
4874	51.98	-3.51	48.47	54	-5.53	AV
7311	57.49	-0.82	56.67	74	-17.33	PK
7311	48.26	-0.82	47.44	54	-6.56	AV

Remark: Factor = Antenna Factor + Cable Loss – Pre-amplifier. Margin = Absolute Level – Limit

CH High of 802.11n/H40 Mode (2452MHz)

Horizontal:

Frequency	Reading Result	Factor	Emission Level	Limits	Margin	Detector
(MHz)	(dBμV)	(dB)	(dBμV/m)	(dBμV/m)	(dB)	Type
4904	62.53	-3.43	59.1	74	-14.9	PK
4904	53.27	-3.43	49.84	54	-4.16	AV
7356	56.29	-0.75	55.54	74	-18.46	PK
7356	47.29	-0.75	46.54	54	-7.46	AV

Remark: Factor = Antenna Factor + Cable Loss – Pre-amplifier. Margin = Absolute Level – Limit

Vertical:

Frequency	Reading Result	Factor	Emission Level	Limits	Margin	Detector
(MHz)	(dBμV)	(dB)	(dBμV/m)	(dBμV/m)	(dB)	Type
4904	62.53	-3.43	59.1	74	-14.9	PK
4904	50.32	-3.43	46.89	54	-7.11	AV
7356	62.53	-0.75	61.78	74	-12.22	PK
7356	47.29	-0.75	46.54	54	-7.46	AV

Remark: Factor = Antenna Factor + Cable Loss – Pre-amplifier. Margin = Absolute Level – Limit

Remark :

- (1) Measuring frequencies from 1 GHz to the 25 GHz.
- (2) "F" denotes fundamental frequency; "H" denotes spurious frequency. "E" denotes band edge frequency.
- (3) \* denotes emission frequency which appearing within the Restricted Bands specified in provision of 15.205, then the general radiated emission limits in 15.209 apply.
- (4) Data of measurement within this frequency range shown "---" in the table above means the reading of emissions are attenuated more than 20dB below the permissible limits or the field strength is too small to be measured.
- (5) The IF bandwidth of EMI Test Receiver between 30MHz to 1GHz was 120KHz, 1 MHz for measuring above 1 GHz, below 30MHz was 10KHz. The resolution bandwidth of test receiver/spectrum analyzer is 1MHz and video bandwidth is 3MHz for peak measurement with peak detector at frequency above 1GHz. The resolution bandwidth of test receiver/spectrum analyzer is 1MHz and video bandwidth is 10Hz for Average measurement with peak detection at frequency above 1GHz.
- (6) When the test results of Peak Detected below the limits of Average Detected, the Average Detected is not need completed. For example: Top Channel at Fundamental 73.16dBuV/m(PK Value) <93.98(AV Limit), at harmonic 53.20 dBuV/m(PK Value) <54 dBuV/m(AV Limit), the Average Detected not need to completed.

## 5. BAND EDGE

### 5.1 Limits

FCC PART 15.247 Emissions radiated outside of the specified frequency bands, except for harmonics, shall be attenuated by at least 20 dB below the level of the fundamental or to the general radiated emission limits in §15.209, whichever is the lesser attenuation.

### 5.2 Test Procedure

The band edge compliance of RF radiated emission should be measured by following the guidance in ANSI C63.10 with respect to maximizing the emission by rotating the EUT, measuring the emission while the EUT is situated in three orthogonal planes (if appropriate), adjusting the measurement antenna height and polarization etc. Set RBW to 1MHz and VBM to 3MHz to measure the peak field strength and set RBW to 1MHz and VBW to 10kHz to measure the average radiated field strength. The conducted RF band edge was measured by using a spectrum analyzer. Set span wide enough to capture the highest in-band emission and the emission at the band edge. Set RBW to 100 KHz and VBW to 300 KHz, to measure the conducted peak band edge.

### 5.3 Test Result

PASS

We tested at 802.11b/802.11g/802.11n HT20/802.11n HT40 mode at the antenna single and recored the worst data 802.11b mode in report.

Horizontal:

Frequency (MHz)	Reading Result (dB $\mu$ V)	Factor (dB)	Emission Level (dB $\mu$ V/m)	Limits (dB $\mu$ V/m)	Margin (dB)	Detector Type
2310	56.93	-5.81	51.12	74	-22.88	PK
2310	48.88	-5.81	43.07	54	-10.93	AV
2390	62.34	-5.84	56.5	74	-17.5	PK
2390	51.27	-5.84	45.43	54	-8.57	AV
2400	64.29	-5.84	58.45	74	-15.55	PK
2400	50.39	-5.84	44.55	54	-9.45	AV

Remark: Factor = Antenna Factor + Cable Loss – Pre-amplifier.

Vertical:

Frequency (MHz)	Reading Result (dB $\mu$ V)	Factor (dB)	Emission Level (dB $\mu$ V/m)	Limits (dB $\mu$ V/m)	Margin (dB)	Detector Type
2310	56.39	-5.81	50.58	74	-23.42	PK
2310	51.29	-5.81	45.48	54	-8.52	AV
2390	63.59	-5.84	57.75	74	-16.25	PK
2390	50.27	-5.84	44.43	54	-9.57	AV
2400	64.38	-5.84	58.54	74	-15.46	PK
2400	51.23	-5.84	45.39	54	-8.61	AV

Remark: Factor = Antenna Factor + Cable Loss – Pre-amplifier.

Horizontal :

Frequency (MHz)	Reading Result (dB $\mu$ V)	Factor (dB)	Emission Level (dB $\mu$ V/m)	Limits (dB $\mu$ V/m)	Margin (dB)	Detector Type
2483.5	56.38	-5.54	50.84	74	-23.16	PK
2483.5	50.29	-5.54	44.75	54	-9.25	AV
2500	57.42	-5.72	51.7	74	-22.3	PK
2500	50.29	-5.72	44.57	54	-9.43	AV

Remark: Factor = Antenna Factor + Cable Loss – Pre-amplifier.

Vertical:

Frequency (MHz)	Reading Result (dB $\mu$ V)	Factor (dB)	Emission Level (dB $\mu$ V/m)	Limits (dB $\mu$ V/m)	Margin (dB)	Detector Type
2483.5	56.39	-5.54	50.85	74	-23.15	PK
2483.5	51.11	-5.54	45.57	54	-8.43	AV
2500	55.37	-5.72	49.65	74	-24.35	PK
2500	50.27	-5.72	44.55	54	-9.45	AV

Remark: Factor = Antenna Factor + Cable Loss – Pre-amplifier.

## 6. OCCUPIED BANDWIDTH MEASUREMENT

### 6.1 Test Limit

FCC Part15(15.247), Subpart C				
Section	Test Item	Limit	Frequency Range (MHz)	Result
15.247(a)(2)	Bandwidth	$\geq 500\text{KHz}$ (6dB bandwidth)	2400-2483.5	PASS

### 6.2 Test Procedure

1. The EUT was placed on a turn table which is 0.8m above ground plane.
2. Set EUT as normal operation.
3. Based on FCC Part15 C Section 15.247: RBW=100KHz, VBW=300KHz.
4. The useful radiated emission from the EUT was detected by the spectrum analyzer with peak detector.

### 6.3 Measurement Equipment Used

Same as Radiated Emission Measurement

### 6.4 Test Result

PASS

TX 802.11b Mode			
Frequency (MHz)	6dB Bandwidth (MHz)	Channel Separation (MHz)	Result
2412	9.805	>=500KHz	PASS
2437	10.24	>=500KHz	PASS
2462	9.520	>=500KHz	PASS

CH: 2412MHz



CH: 2437MHz

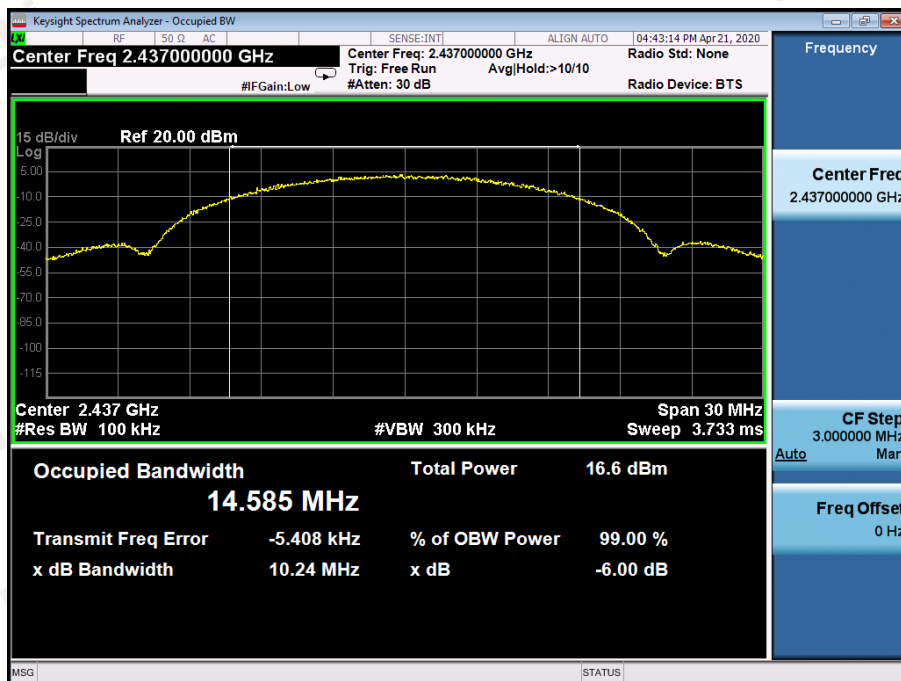



CH: 2462MHz

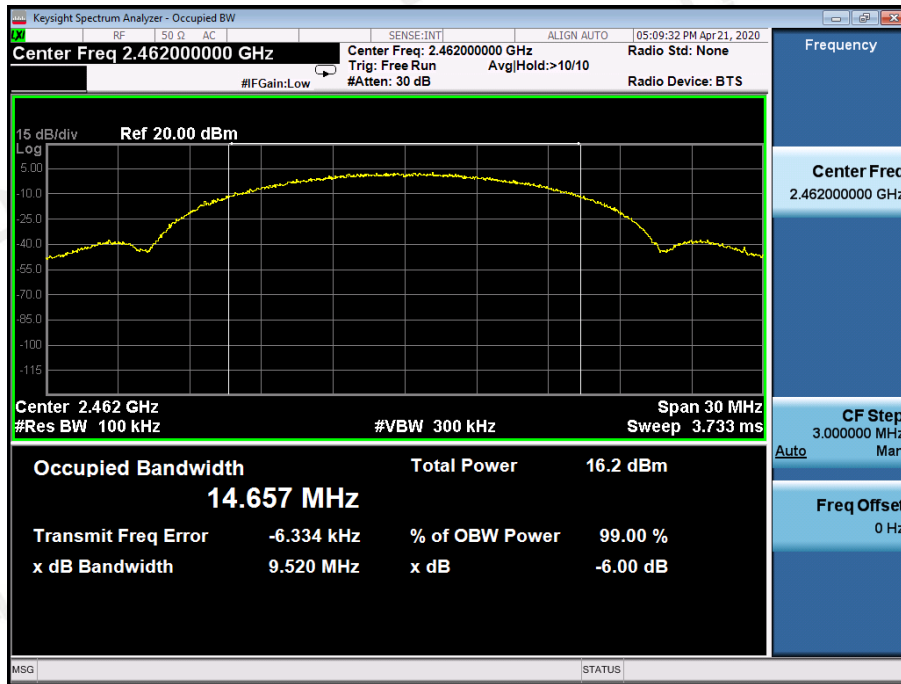

TX 802.11g Mode			
Frequency (MHz)	6dB Bandwidth (MHz)	Channel Separation (MHz)	Result
2412	16.41	>=500KHz	PASS
2437	16.41	>=500KHz	PASS
2462	16.40	>=500KHz	PASS

CH: 2412MHz

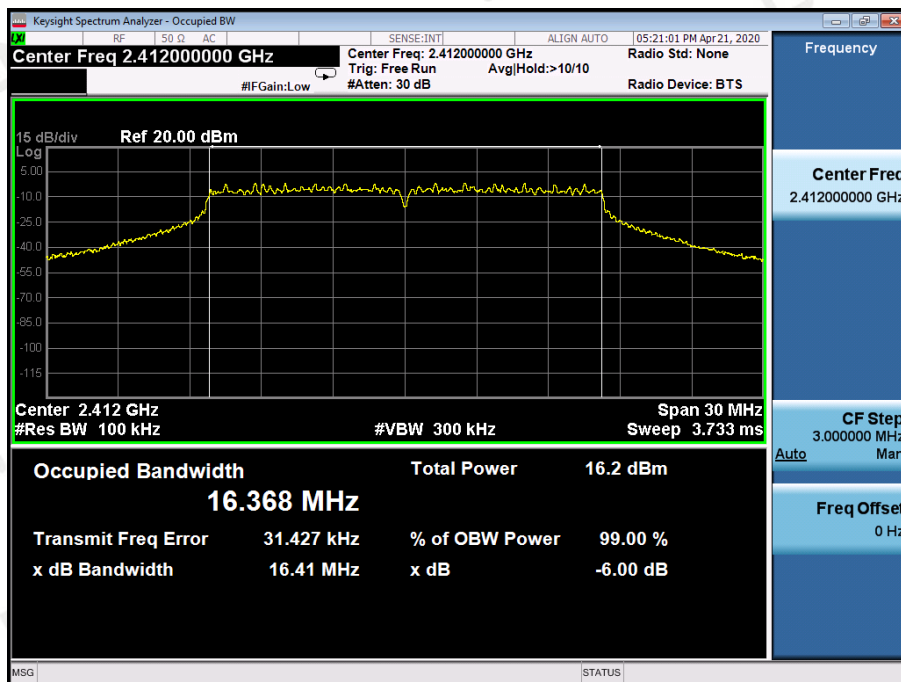

CH: 2437MHz

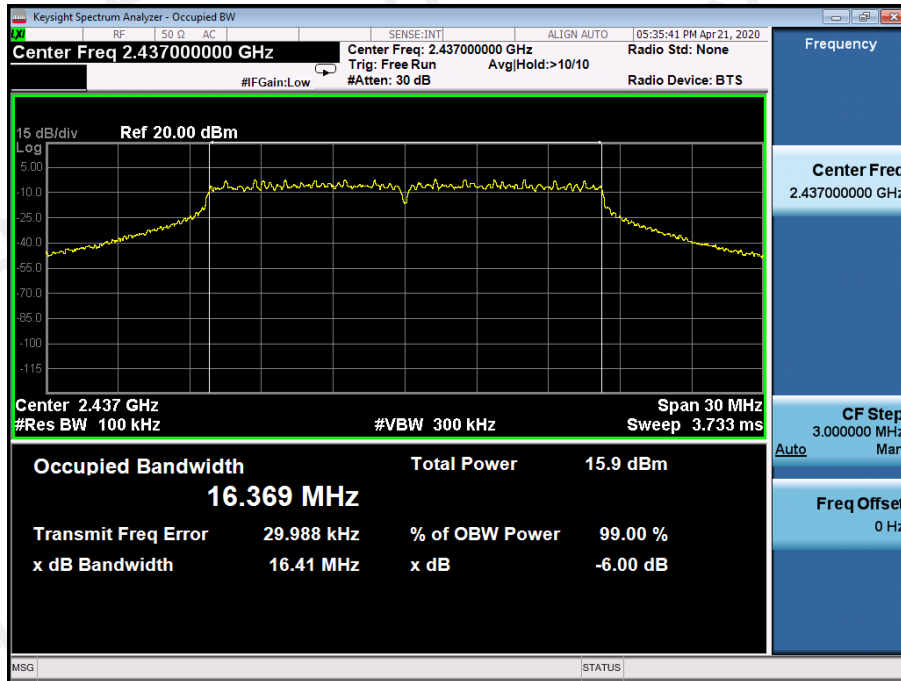

CH: 2462MHz

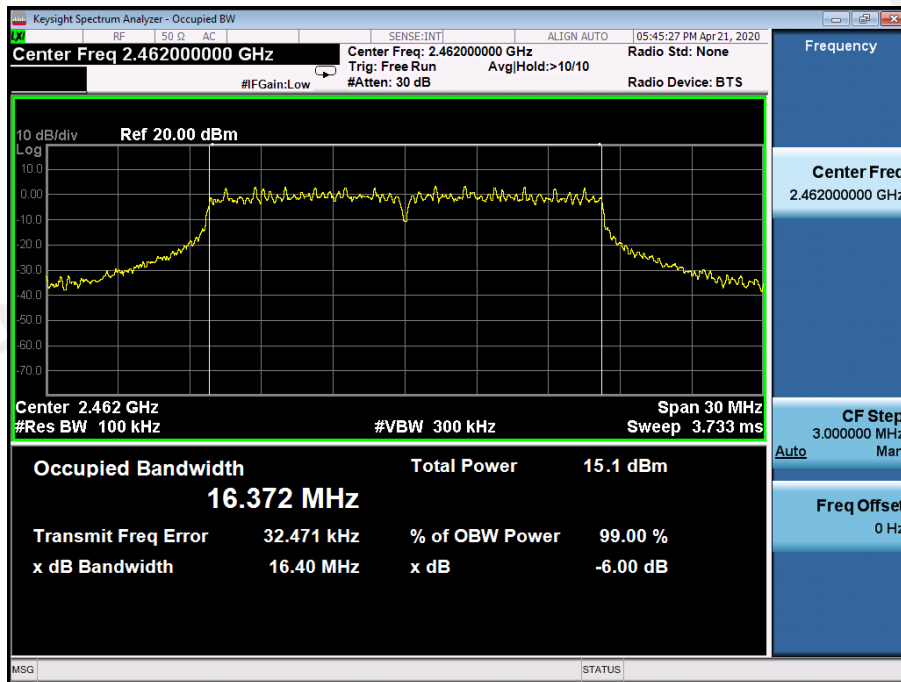

TX 802.11n/HT20 Mode			
Frequency (MHz)	6dB Bandwidth (MHz)	Channel Separation (MHz)	Result
2412	16.40	>=500KHz	PASS
2437	16.40	>=500KHz	PASS
2462	16.40	>=500KHz	PASS

CH: 2412MHz

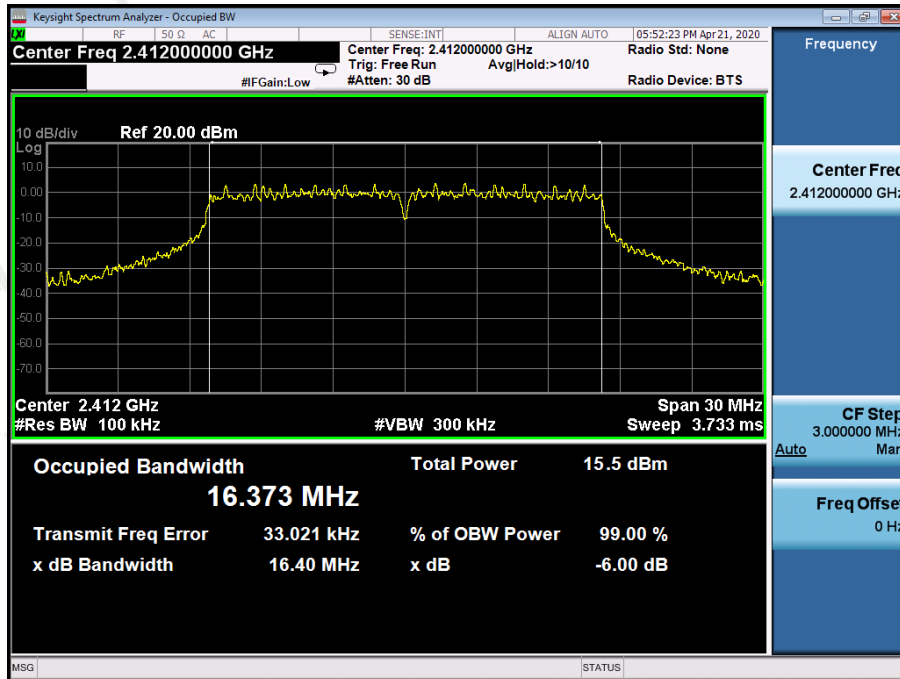

CH: 2437MHz

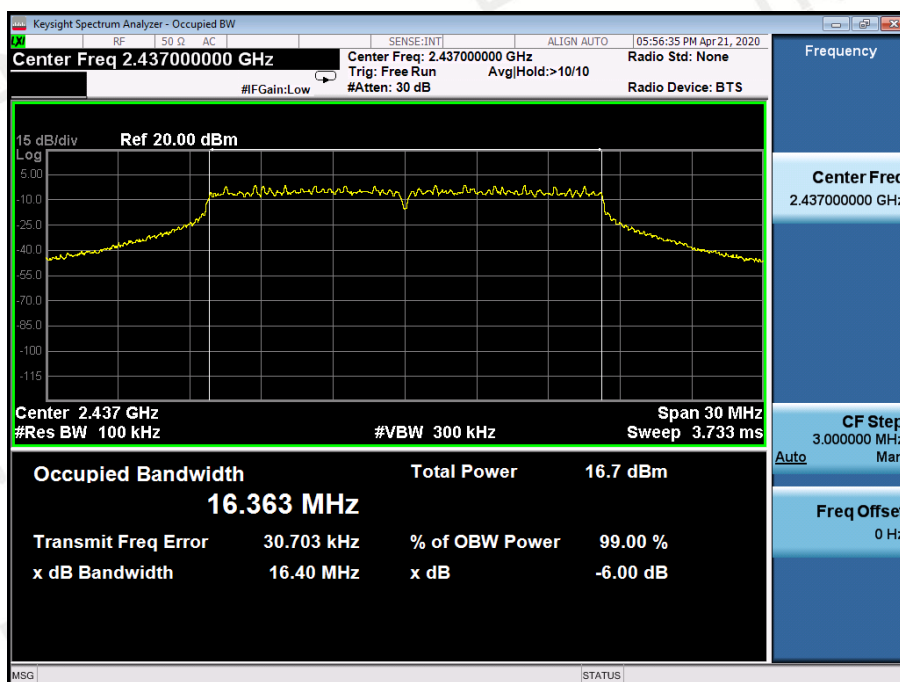

CH: 2462MHz

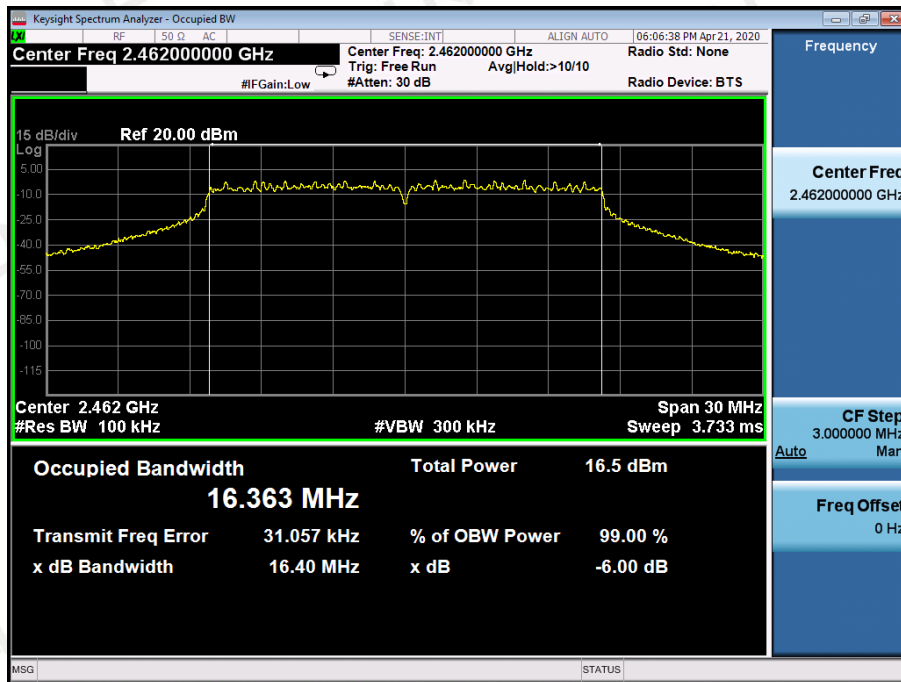

TX 802.11n/HT40 Mode			
Frequency (MHz)	6dB Bandwidth (MHz)	Channel Separation (MHz)	Result
2422	36.06	>=500KHz	PASS
2437	36.06	>=500KHz	PASS
2452	36.05	>=500KHz	PASS

CH: 2422MHz

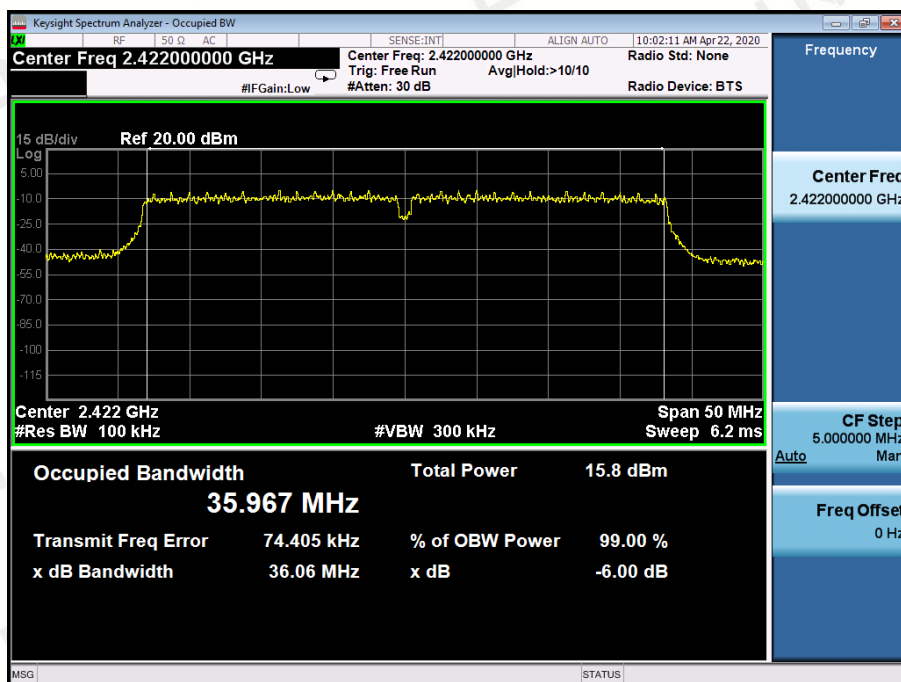

CH: 2437MHz

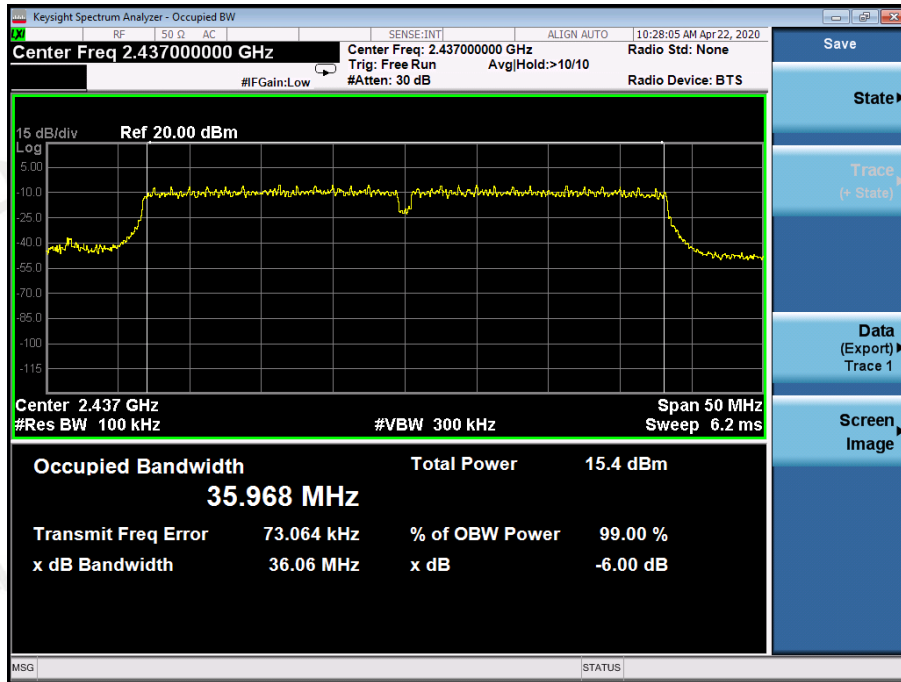

CH: 2452MHz

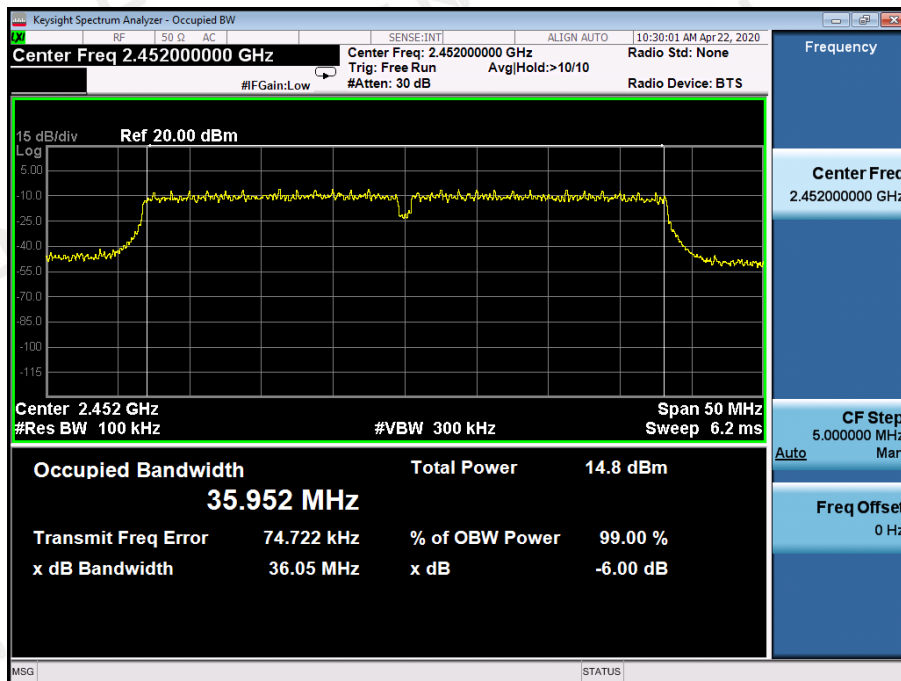

## 7. POWER SPECTRAL DENSITY TEST

### 7.1 Test Limit

FCC Part15(15.247), Subpart C				
Section	Test Item	Limit	Frequency Range (MHz)	Result
15.247	Power Spectral Density	8 dBm (in any 3KHz)	2400-2483.5	PASS

### 7.2 Test Procedure

1. The EUT was placed on a turn table which is 0.8m above ground plane.
2. Set EUT as normal operation.
3. Based on FCC Part15 C Section 15.247: RBW=3KHz, VBW=10KHz.
4. The useful radiated emission from the EUT was detected by the spectrum analyzer with peak detector.

### 7.3 Measurement Equipment Used

Same as Radiated Emission Measurement

### 7.4 Test Result

PASS

TX 802.11b Mode			
Frequency (MHz)	Power Density (dBm/3KHz)	Limit (dBm/3KHz)	Result
2412	-10.611	8	PASS
2437	-12.039	8	PASS
2462	-11.329	8	PASS

CH: 2412MHz

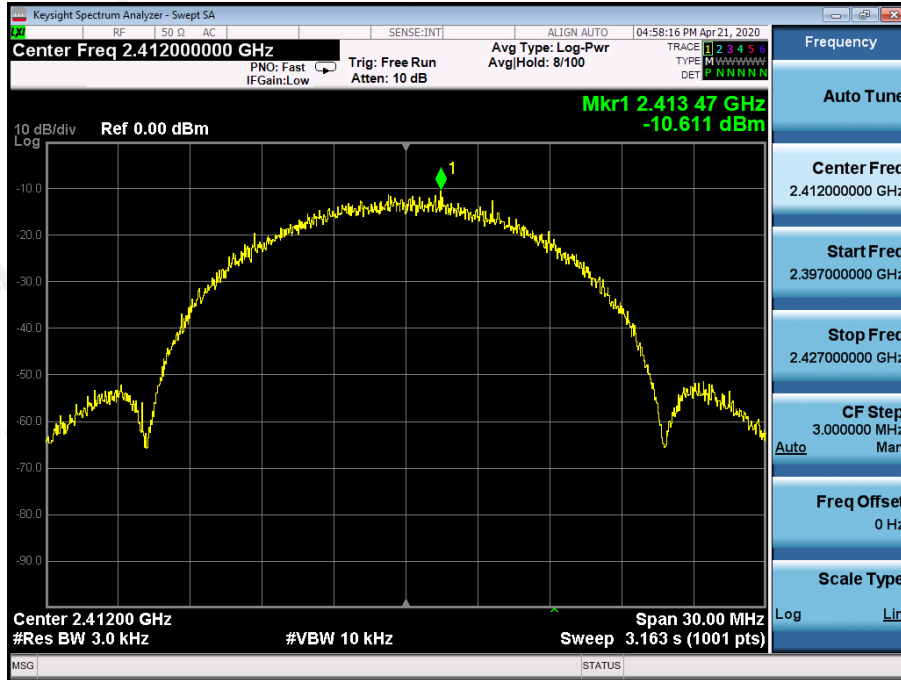

CH: 2437MHz

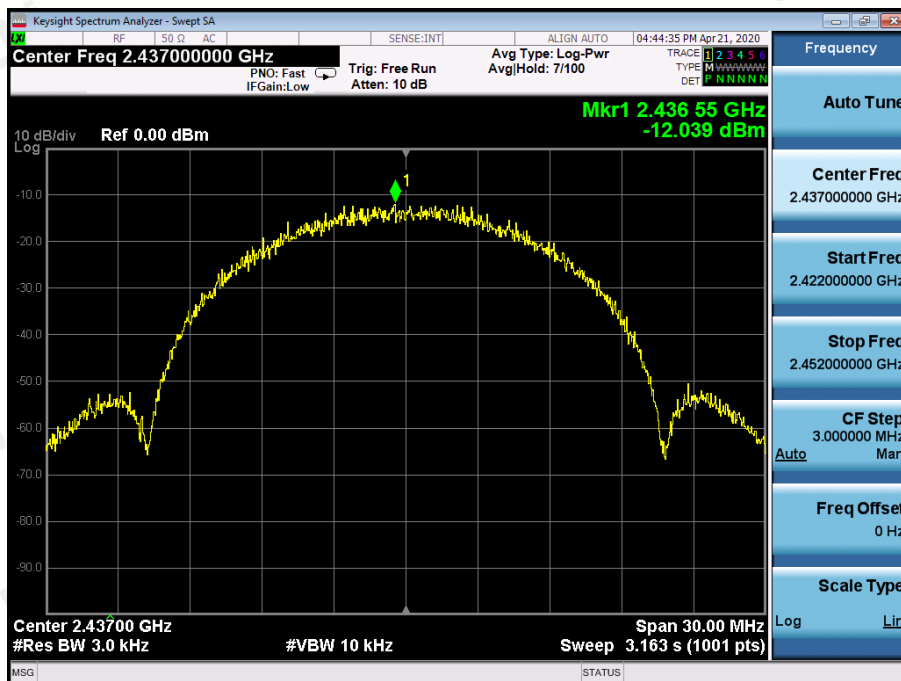

CH: 2462MHz

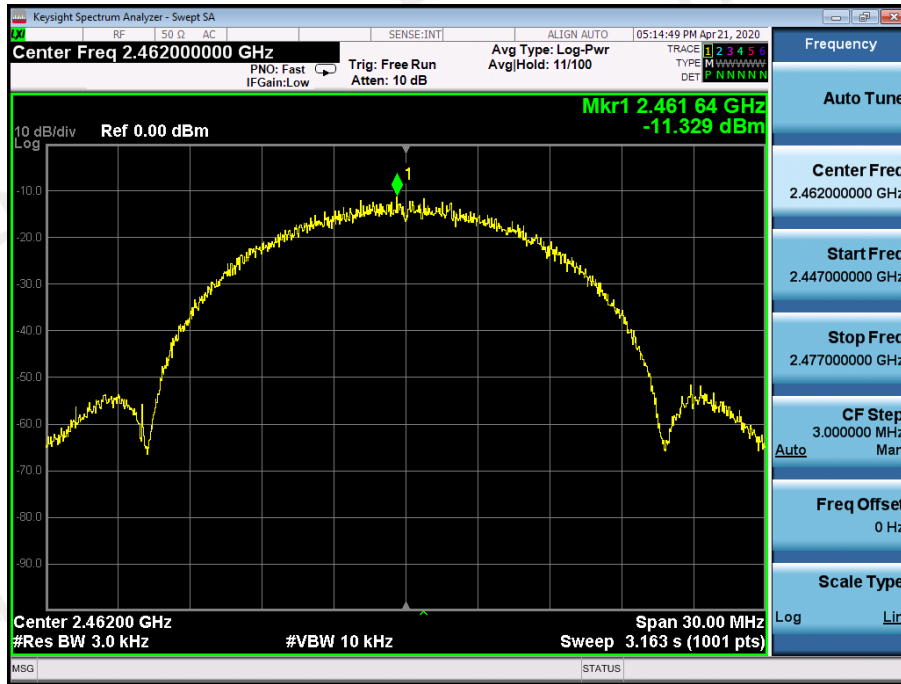

TX 802.11g Mode			
Frequency (MHz)	Power Density (dBm/3KHz)	Limit (dBm/3KHz)	Result
2412	-13.910	8	PASS
2437	-14.503	8	PASS
2462	-12.456	8	PASS

CH: 2412MHz

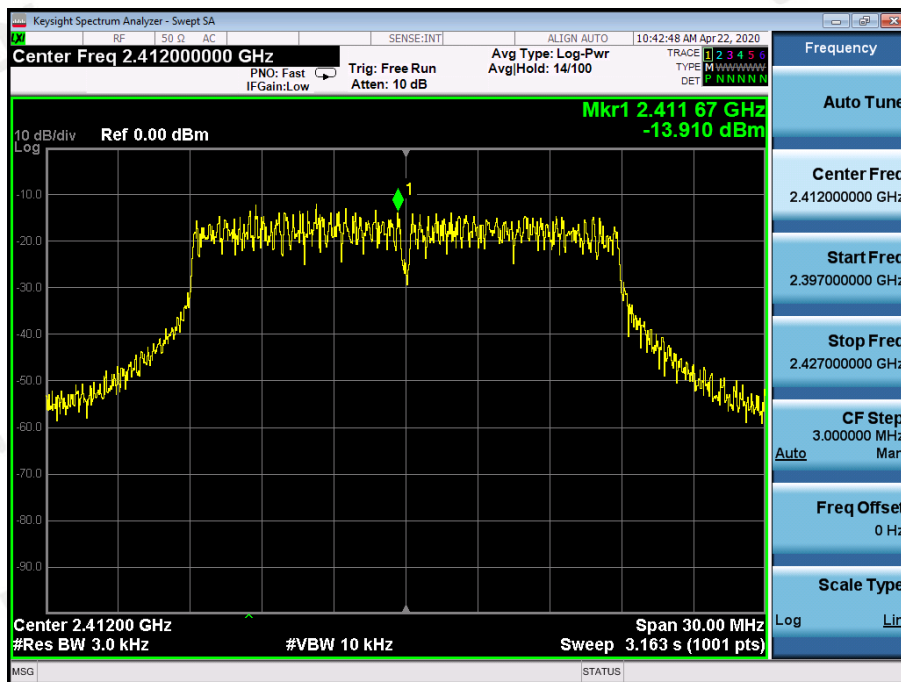



CH: 2437MHz

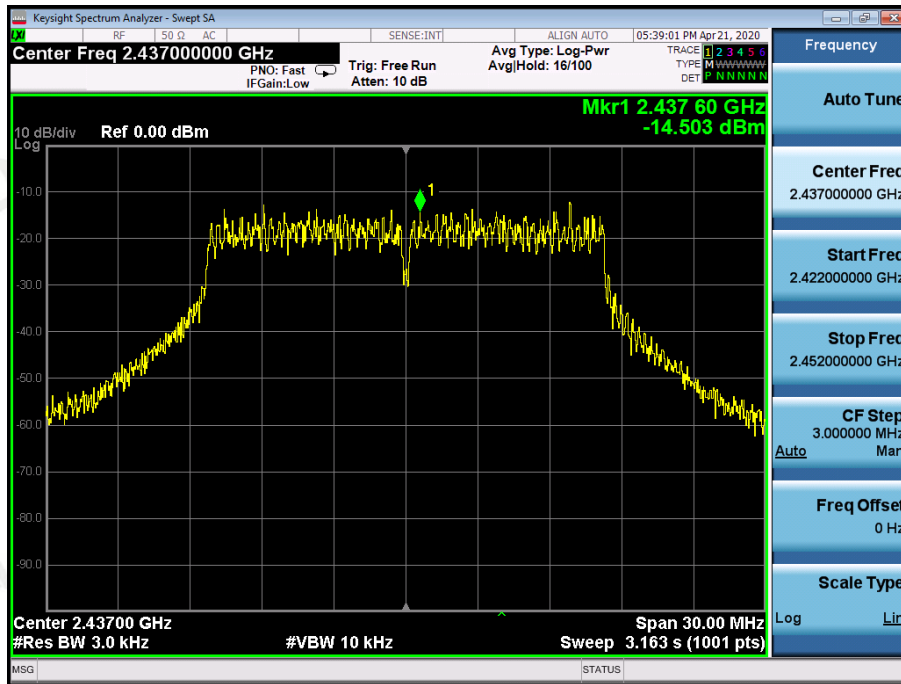

CH: 2462MHz

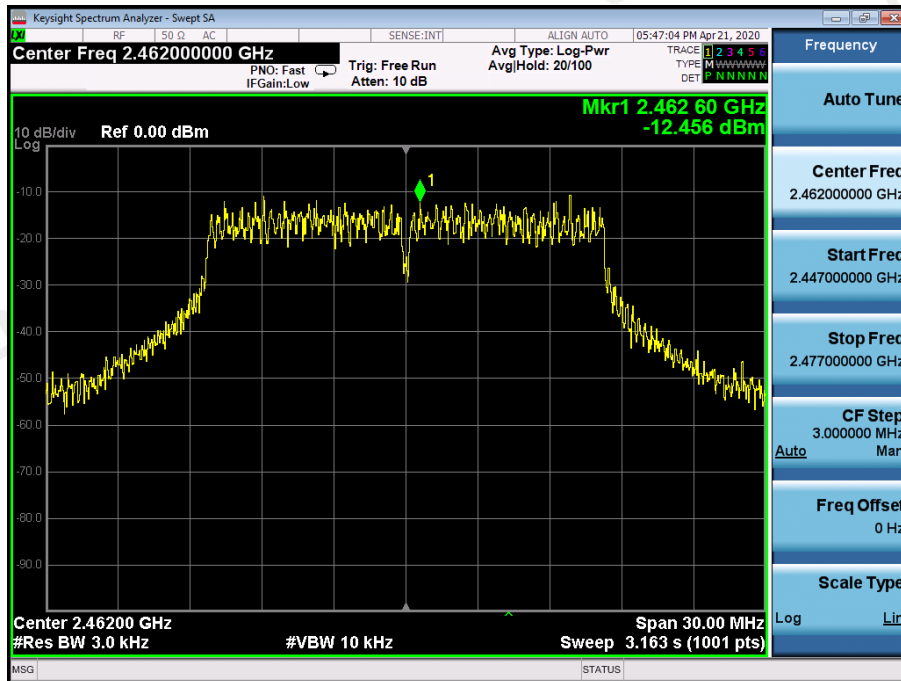

TX 802.11n/HT20 Mode			
Frequency (MHz)	Power Density (dBm/3KHz)	Limit (dBm/3KHz)	Result
2412	-11.834	8	PASS
2437	-14.325	8	PASS
2462	-14.468	8	PASS

CH: 2412MHz

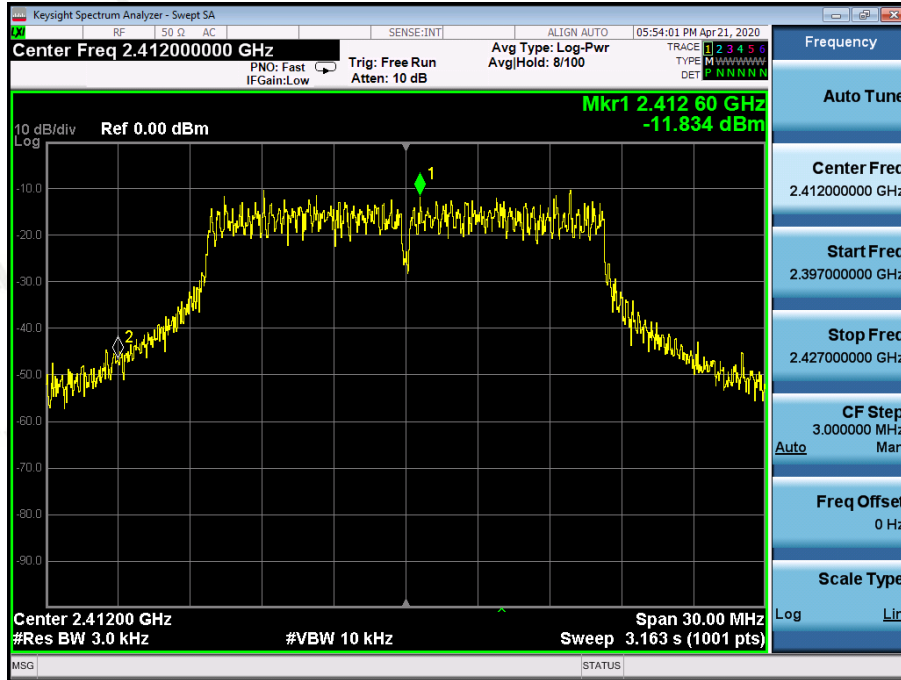

CH: 2437MHz

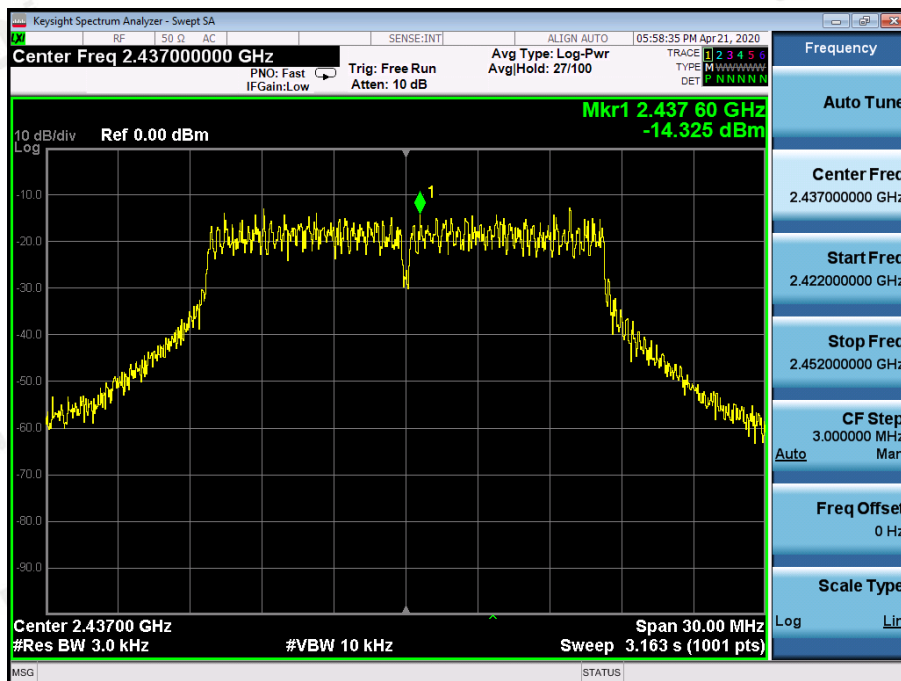

CH: 2462MHz

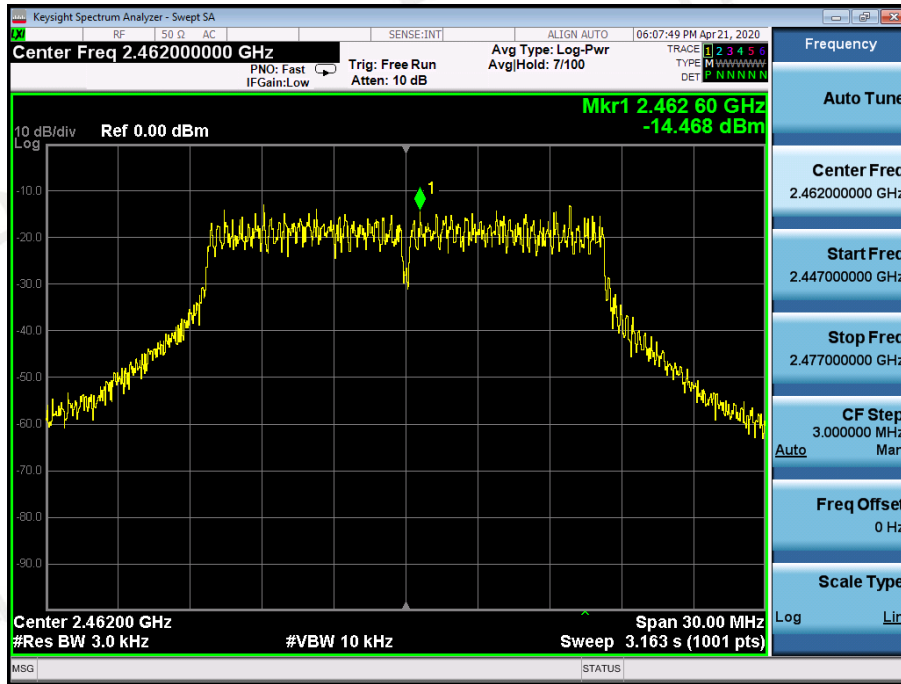

TX 802.11n/HT40 Mode			
Frequency (MHz)	Power Density (dBm/3KHz)	Limit (dBm/3KHz)	Result
2422	-10.713	8	PASS
2437	-13.047	8	PASS
2452	-12.702	8	PASS

CH: 2422MHz

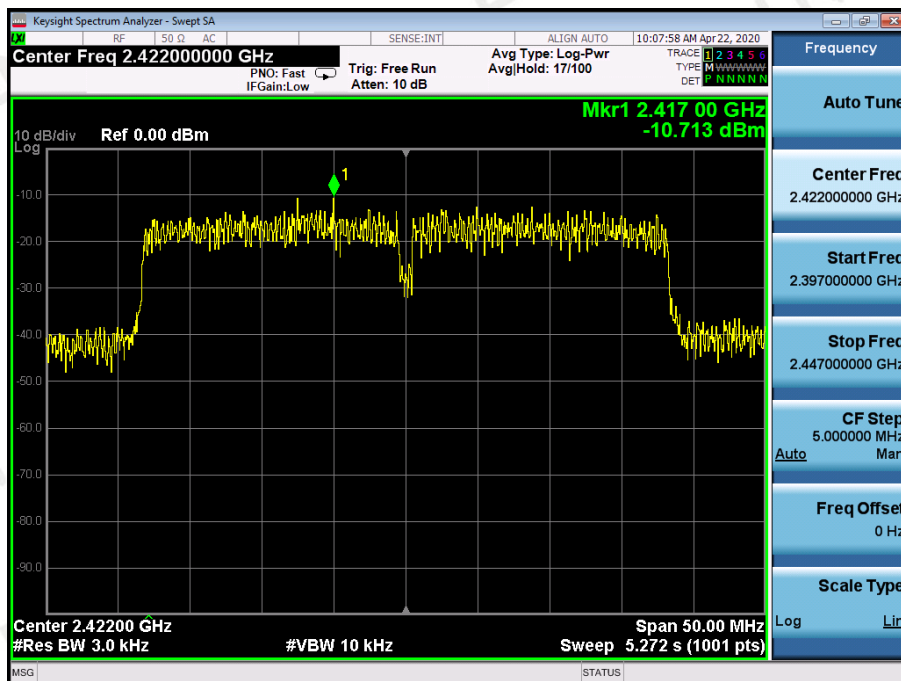

CH: 2437MHz

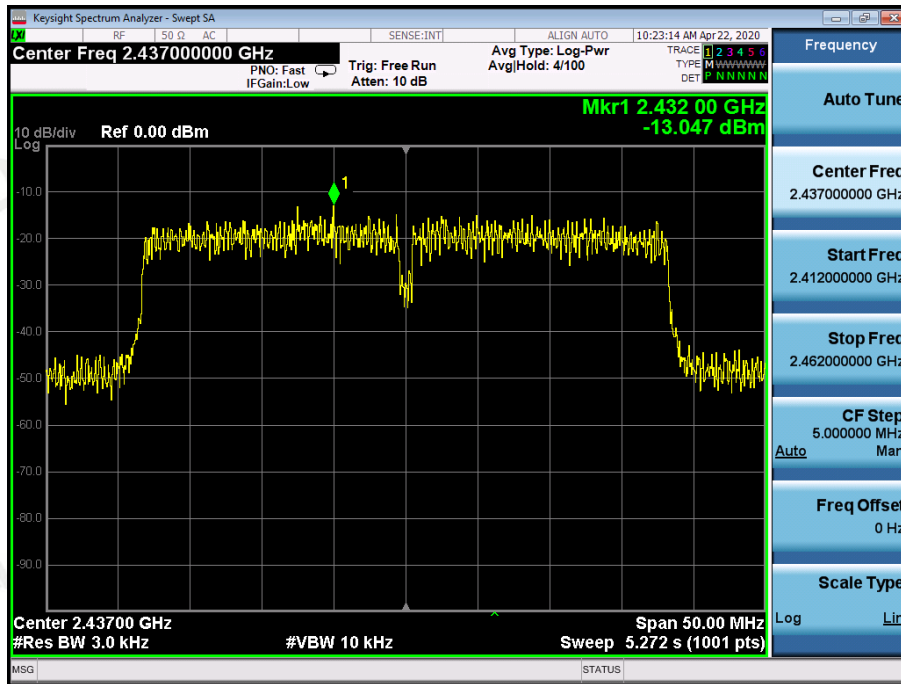

CH: 2452MHz

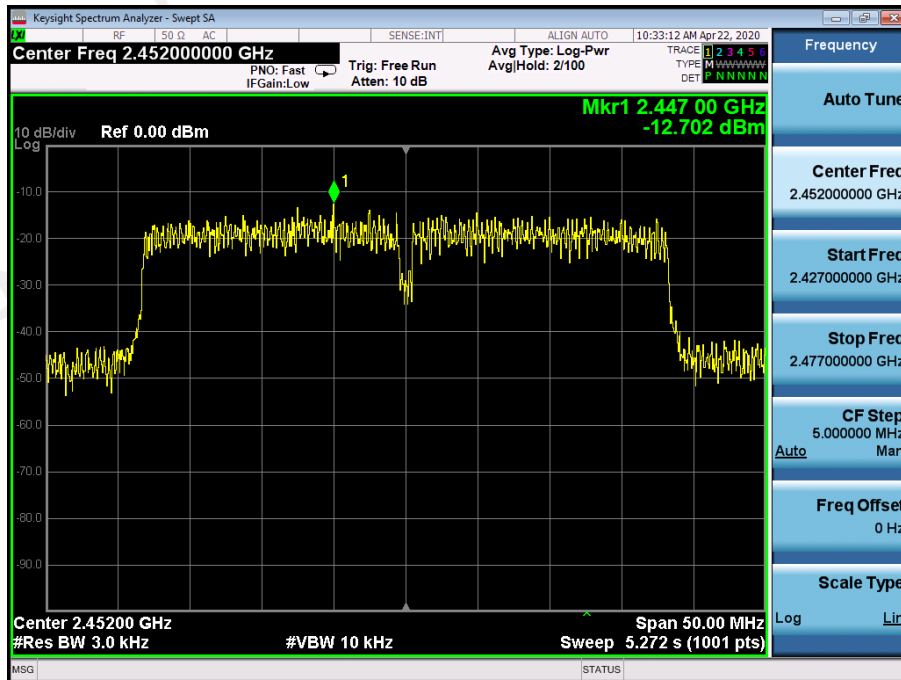

## 8. PEAK OUTPUT POWER TEST

### 8.1 Test Limit

FCC Part15(15.247), Subpart C				
Section	Test Item	Limit	Frequency Range (MHz)	Result
15.247(b)(3)	Peak Output Power	1 watt or 30dBm	2400-2483.5	PASS

### 8.2 Test Procedure

1. The EUT was directly connected to the Power meter.

### 8.3 Measurement Equipment Used

Same as Radiated Emission Measurement

### 8.4 Test Result

PASS

All the test modes completed for test.

TX 802.11b Mode			
Test Channel	Frequency (MHz)	Maximum Peak Conducted Output Power (dBm)	LIMIT (dBm)
CH01	2412	<b>10.453</b>	30
CH06	2437	9.436	30
CH11	2462	9.863	30
TX 802.11g Mode			
CH01	2412	8.961	30
CH06	2437	9.058	30
CH11	2462	9.348	30
TX 802.11n20 Mode			
CH01	2412	9.624	30
CH06	2437	9.237	30
CH11	2462	9.461	30
TX 802.11n40 Mode			
CH03	2422	8.113	30
CH06	2437	8.597	30
CH09	2452	8.679	30

Note:

- 1) Measured output power at difference data rate for each mode and recorded worst case for each mode.
- 2). Test results including cable loss.

## 9. OUT OF BAND EMISSIONS TEST

### 9.1 Test Limit

In any 100 kHz bandwidth outside the frequency band in which the spread spectrum or digitally modulated intentional radiator is operating, the radio frequency power that is produced by the intentional radiator shall be at least 20 dB below that in the 100 kHz bandwidth within the band that contains the highest level of the desired power, based on either an RF conducted or a radiated measurement, provided the transmitter demonstrates compliance with the peak conducted power limits. If the transmitter complies with the conducted power limits based on the use of RMS averaging over a time interval, as permitted under paragraph (b)(3) of this section, the attenuation required under this paragraph shall be 30 dB instead of 20 dB.

### 9.2 Test Procedure

1. The EUT was placed on a turn table which is 0.8m above ground plane.
2. Set EUT as TX operation and connect directly to the spectrum analyzer.
3. Based on FCC Part15 C Section 15.247: RBW=100KHz, VBW=300KHz.
4. Set detected by the spectrum analyzer with peak detector.

### 9.3 Test Setup

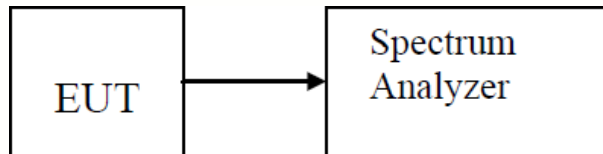

### 9.4 Test Result

PASS

802.11b			
Frequency (MHz)	Delta Peak to Band emission (dBc)	Limit (dBc)	Verdict
2400.00	41.192	20	PASS
2483.50	58.887	20	PASS

	2412		2462
--	------	--	------

802.11g			
Frequency (MHz)	Delta Peak to Band emission (dBc)	Limit (dBc)	Verdict
2400.00	33.307	20	PASS
2483.05	48.116	20	PASS

	2412		2462
--	------	--	------

802.11n HT20			
Frequency (MHz)	Delta Peak to Band emission (dBc)	Limit (dBc)	Verdict
2400.00	32.729	20	PASS
2483.50	47.800	20	PASS

	2412
	2462

802.11n HT40			
Frequency (MHz)	Delta Peak to Band emission (dBc)	Limit (dBc)	Verdict
2400.00	27.180	20	PASS
2483.50	30.973	20	PASS

	2412
	2462



## 10. SPURIOUS RF CONDUCTED EMISSION

### 10.1 Test Limit

1. Below -20dB of the highest emission level in operating band.
2. Fall in the restricted bands listed in section 15.205. The maximum permitted average field strength is listed in section 15.209.
3. For below 30MHz, For 9KHz-150kHz, 150K-10MHz, We use the RBW 1KHz, 10KHz, So the limit need to calculated by " $10\lg(BW1/BW2)$ ". for example For 9KHz-150kHz, RBW 1KHz, The Limit= the highest emission level-20-10log(100/1)= the highest emission level-40.

### 10.2 Test Procedure

The Spurious RF conducted emissions compliance of RF radiated emission should be measured by following the guidance in ANSI C63.10-2013, For 9KHz-150kHz, Set RBW=1kHz and VBW= 3KHz; For 150KHz-10MHz, Set RBW=10kHz and VBW= 30KHz; For 10MHz-25GHz, Set RBW=100kHz and VBW= 300KHz in order to measure the peak field strength, and measure frequency range from 9KHz to 25GHz.

### 10.3 Test Setup

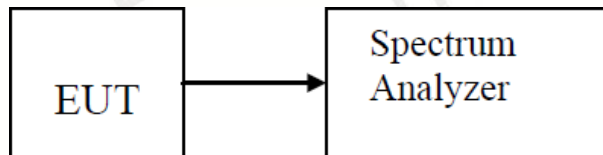

### 10.4 Test Result

PASS

Remark: The measurement frequency range is from 9KHz to the 10th harmonic of the fundamental frequency. The lowest, middle and highest channels are tested to verify the spurious emissions and bandedge measurement data. and record the worstest data for 802.11b in report .

Test Mode:

802.11b

Test channel :

01

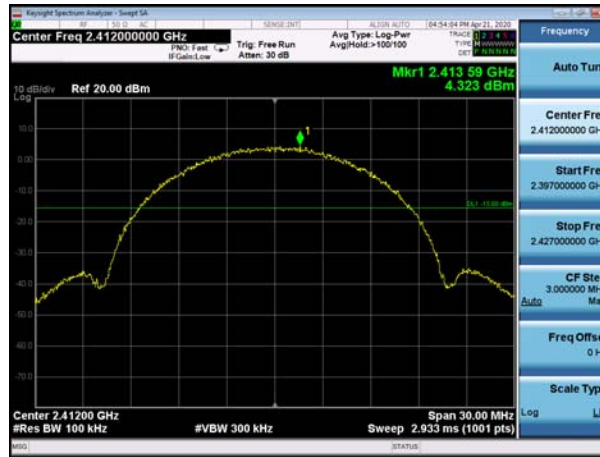

Channel 01

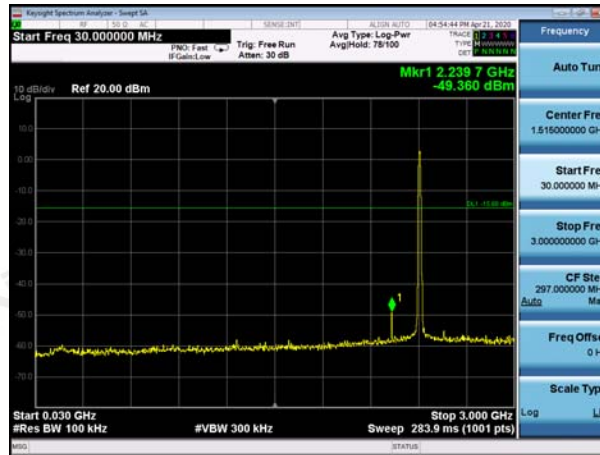

30MHz ~3GHz

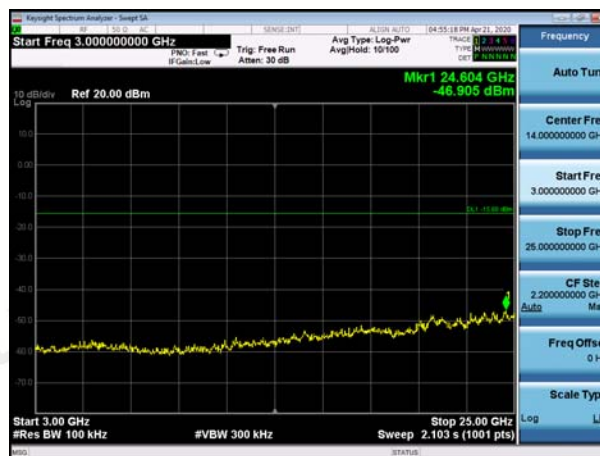

3GHz~25GHz

Test Mode:

802.11b

Test channel :

06

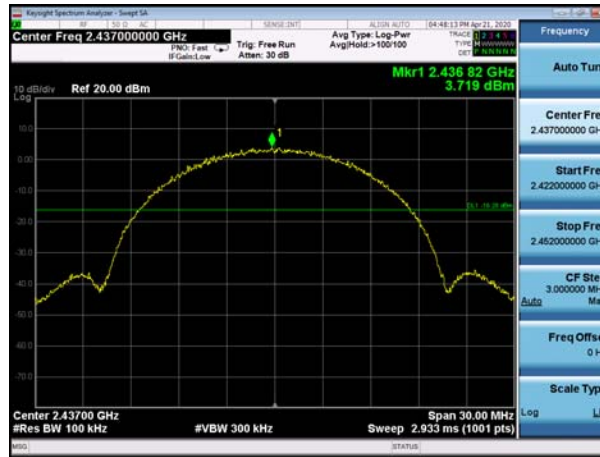

Channel 06

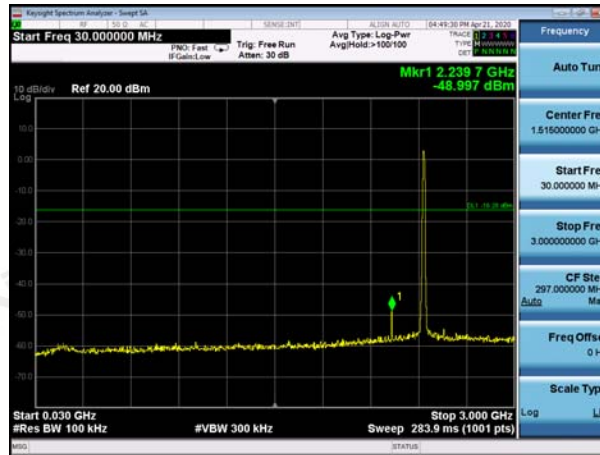

30MHz ~3GHz

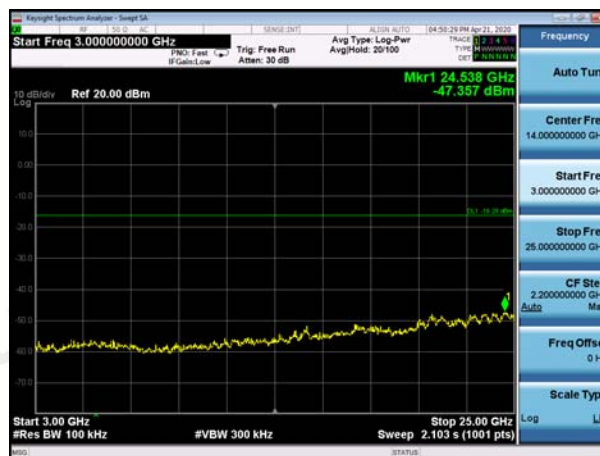

3GHz~25GHz

Test Mode:

802.11b

Test channel :

11



Channel 11

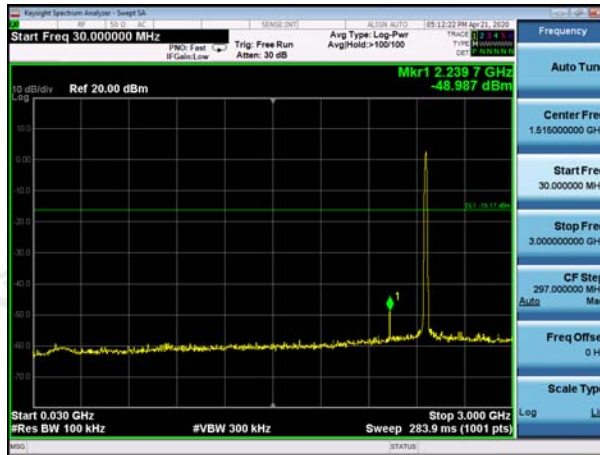

30MHz ~3GHz

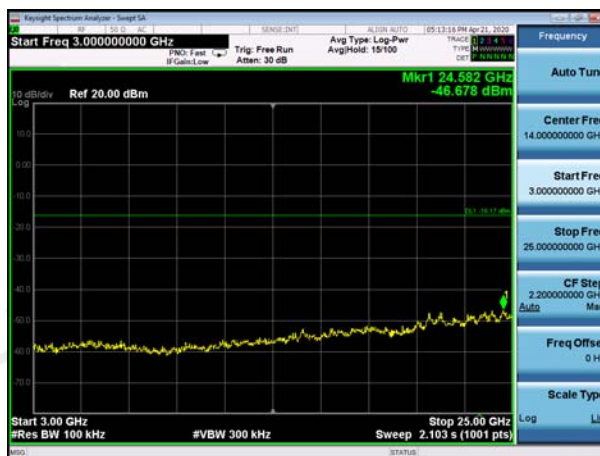

3GHz~25GHz

## 11. ANTENNA REQUIREMENT

Standard Applicable:

For intentional device, according to FCC 47 CFR Section 15.203, an intentional radiator shall be designed to ensure that no antenna other than that furnished by the responsible party shall be used with the device.

Antenna Connected Construction

The antenna used in this product is an Internal Antenna, The directional gains of antenna used for transmitting is 2.08dBi.

ANTENNA:

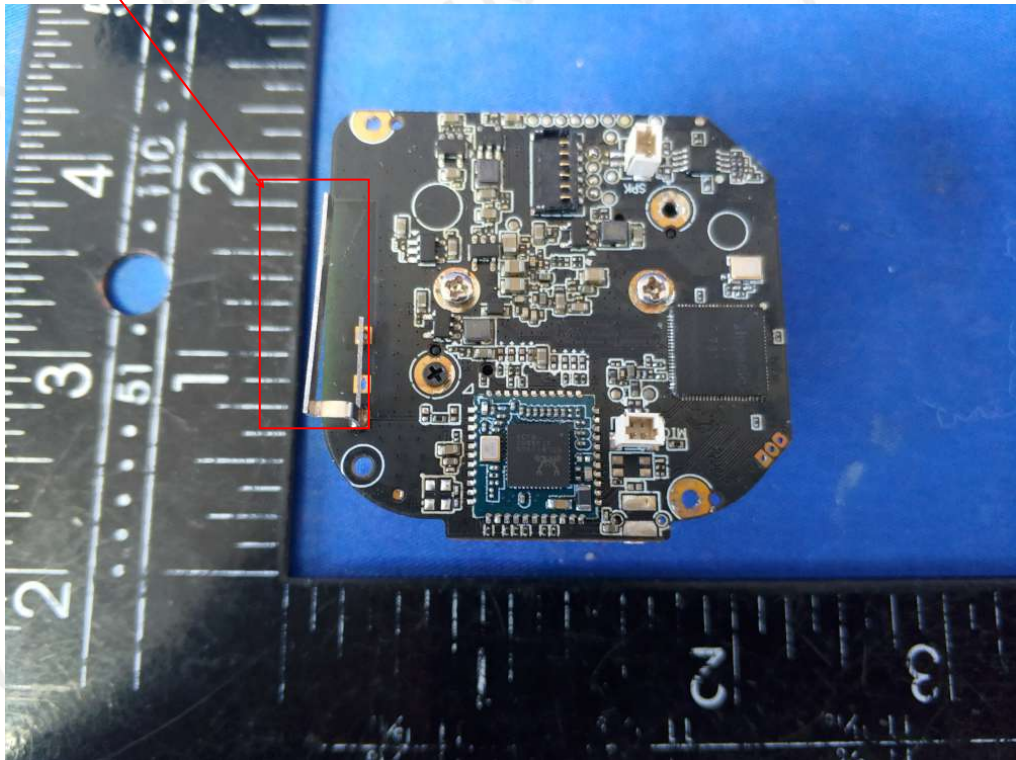

12.PHOTOGRAPH OF TEST

**Radiated Emission  
(Below 1G)**



**Radiated Emission  
(Above 1G)**

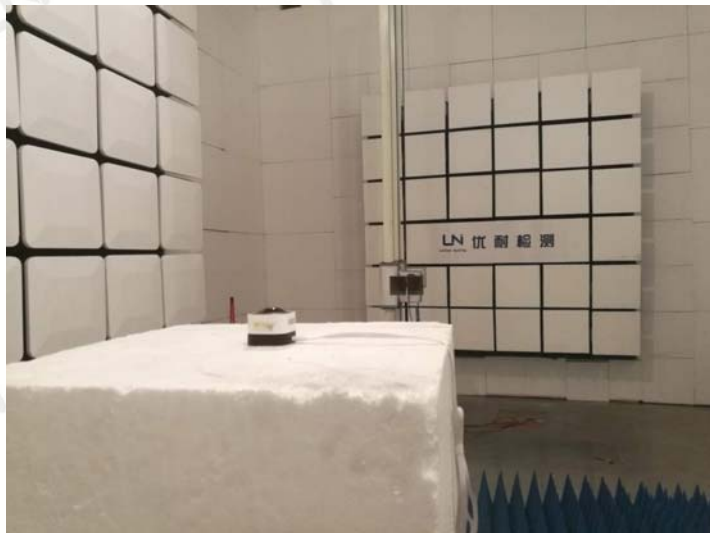

**Conducted Emission**



\*\*\*End of Report\*\*\*