

SEEYING

PROFESSIONAL TURNTABLE WITH USB DIRECT ENCODING

TT-930E-BT-BTT



USER MANUAL

PLEASE READ THIS USER MANUAL COMPLETELY BEFORE OPERATING THIS UNIT
AND RETAIN THIS BOOKLET FOR FUTURE REFERENCE.

WARNING

TO PREVENT FIRE OR SHOCK HAZARD, DO NOT USE THIS PLUG WITH AN EXTENSION CORD, RECEPTACLE OR OTHER OUTLET UNLESS THE BLADES CAN BE FULLY INSERTED TO PREVENT BLADE EXPOSURE. TO PREVENT FIRE OR SHOCK HAZARD, DO NOT EXPOSE THIS APPLIANCE TO RAIN OR MOISTURE.



THE CAUTION MARKING AND RATING LABEL ARE LOCATED AT THE BACK OF THE UNIT

IMPORTANT SAFETY INSTRUCTIONS

1. Read these instructions.
2. Keep these instructions.
3. Heed all warnings.
4. Follow all instructions.
5. Do not use this apparatus near water.
6. Clean only with dry cloth.
7. Do not block any ventilation openings. Install in accordance with the manufacturer's instructions.
8. Do not install near any heat sources such as radiators, heat registers, stoves, or other apparatus (including amplifiers) that product heat.
9. Do not defeat the safety purpose of the polarized or grounding-type plug. A polarized plug has two blades with one wider than the other. A grounding type plug has two blades and a third grounding prong. The wide blade or the third prong is provided for your safety. If the provided plug does not fit into your outlet, consult an electrician for replacement of the obsolete outlet.
10. Protect the power cord from being walked on or pinched particularly at plugs, convenience receptacles, and the point where they exit from the apparatus.
11. Only use attachments/accessories specified by the manufacturer.
12. Use only with a cart, stand, tripod, bracket, or table recommended by the manufacturer, or sold with the product. When a cart is used, use caution when moving the cart/apparatus combination to avoid injury from tip-over.
13. Unplug this apparatus during lightning storms or when unused for a long periods of time.
14. Refer all servicing to qualified service personnel. Servicing is required when the apparatus has been damaged in any way, such as power-supply cord or plug is damaged, liquid has been spilled or objects have fallen into the apparatus, the apparatus has been exposed to rain or moisture, does not operate normally, or has been dropped.
15. This appliance shall not be exposed to dripping or splashing water and that no object filled with liquids such as vases shall be placed on the apparatus.
16. Do not overload wall outlet. Use only power source as indicated.
17. Use replacement part as specified by the manufacturer.
18. Upon completion of any service or repairs to this product, ask the service technician to perform safety checks.



19. Power Sources - This product should be operated only from the type of power source indicated on the marking label. If you are not sure of the type of power supply to your home, consult your product dealer or local power company. For products intended to operate from battery power, or other sources, refer to the operating instruction.
20. Object and Liquid Entry - Never push objects of any kind into this product through openings as they may touch dangerous voltage points or short-out parts that could result in a fire or electric shock. Never spill liquid of any kind on the product.
21. Damage Requiring Service - Unplug this product from the wall outlet and refer servicing to qualified service personnel under the following conditions:
 - a) When the power-supply cord or plug is damaged,
 - b) If liquid has been spilled, or objects have fallen into the product,
 - c) If the product has been exposed to rain or water,
 - d) If the product does not operate normally by following the operating instructions. Adjust only those controls that are covered by the operating instructions as an improper adjustment of other controls may result in damage and will often require extensive work by a qualified technician to restore the product to its normal operation.
 - e) If the product has been dropped or damaged in any way, and
 - f) When the product exhibits a distinct change in performance - this indicates a need for service.
22. Mains plug is used as disconnect device and it should remain readily operable during intended use. In order to disconnect the apparatus from the mains completely, the mains plug should be disconnected from the mains socket outlet completely.
23. Excessive sound pressure from earphones and headphone can cause hearing loss.
24. Minimum distances of 10 cm around the apparatus for sufficient ventilation
25. The ventilation should not be impeded by covering the ventilation openings with items, such as newspapers, table-cloths, curtains, etc.
26. No naked flame sources, such as lighted candles, should be placed on the apparatus.
27. The use of apparatus in moderate climates.

This symbol indicates that this product incorporates double insulation between hazardous mains voltage and user accessible parts.

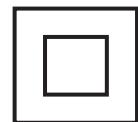

CAUTION

TO PREVENT ELECTRIC SHOCK, MATCH WIDE BLADE OF PLUG TO WIDE SLOT. FULLY INSERT THE PLUG TO MAIN POWER SOCKET.

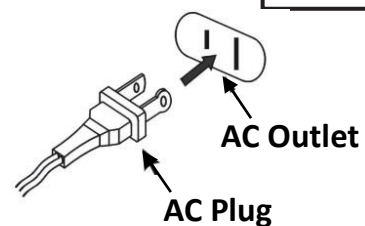

SAVE THESE INSTRUCTIONS

IMPORTANT NOTES

Avoid installing the unit in locations described below:

- Places exposed to direct sunlight or close to heat radiating appliances such as electric heaters.
- Places subject to constant vibration.
- Dusty, humid or moist places.
- Unplug the unit from the electrical power outlet immediately in case of malfunction.

This device complies with Part 15 of the FCC Rules. Operation is subject to the following two conditions:

- (1) This device may not cause harmful interference.
- (2) This device must accept any interference received, including interference that

may cause undesired operation.

LOCATION OF CONTROLS

- 1) Dust cover
- 2) Spindle adaptor
- 3) Counter weight
- 4) Pitch adjust
- 5) Cueing lever
- 6) Turntable speed selector
- 7) Tone-arm lock
- 8) Bluetooth transmit function button
- 9) Record TS (Track Separation) button
- 10) Record button
- 11) Record LED indicator
- 12) Play / Pause / Stop button
- 13) Play / Pause LED indicator
- 14) Power button
- 15) Function button
- 16) Volume up/down and Skip up / down button
- 17) USB socket
- 18) Repeat Mode LED indicator
- 19) Phono LED indicator
- 20) Play Mode button
- 21) Bluetooth LED indicator
- 22) Random LED indicator
- 23) USB LED indicator
- 24) Folder up button
- 25) Phono line out socket (L/R)
- 26) DC in jack
- 27) AC/DC adaptor
- 28) DC plug

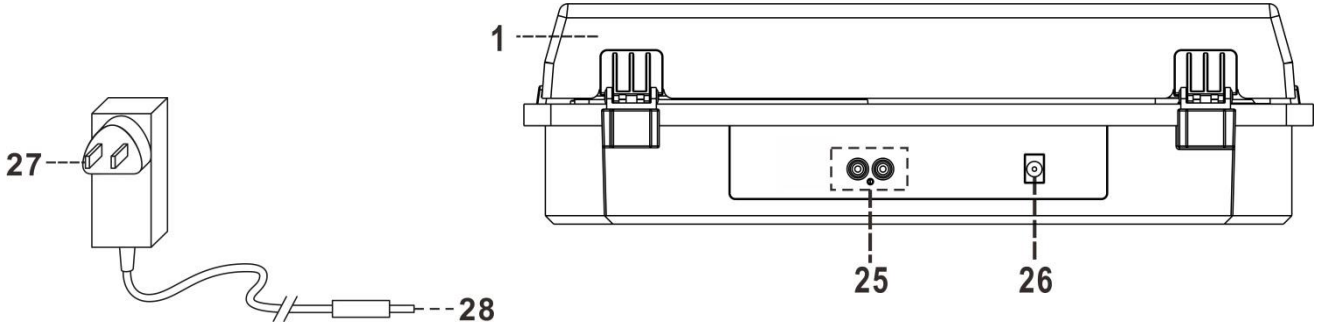
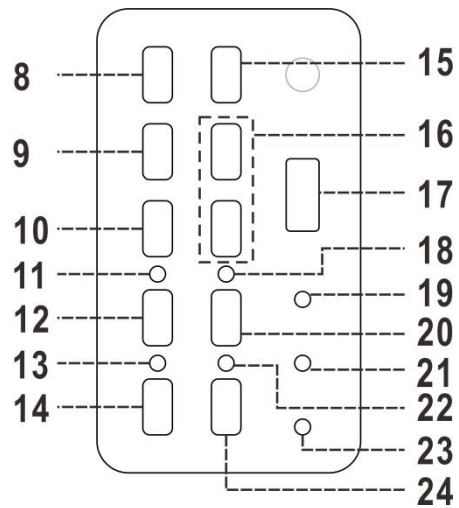
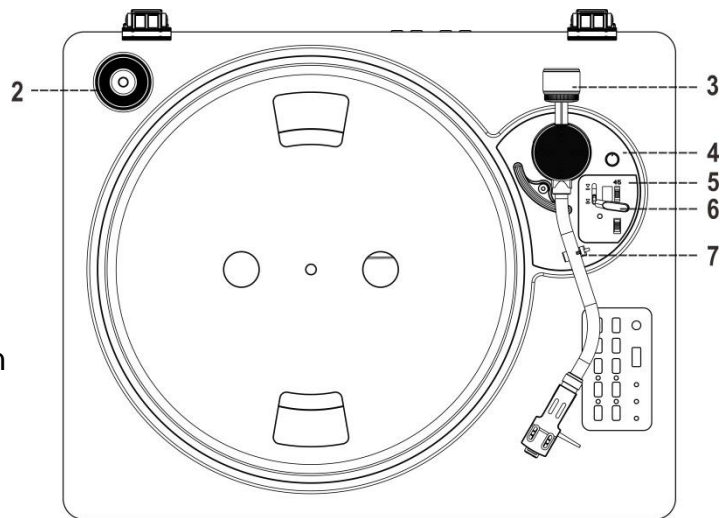

Caution:

Usage of controls or adjustments or performance of procedures other than those specified herein may result in hazardous radiation exposure. This unit should not be adjusted or repaired by anyone except qualified service personnel.

Accessory List

- | | |
|-------------------------|---------------------------|
| 1. 45 rpm adaptor x 1pc | 3. Slip mat x 1pc |
| 2. Counter weight x 1pc | 4. Instruction book x 1pc |

Precautions for use

Installation

- Unpack all parts and remove protective material.
- Do not connect the unit to the mains before checking the mains voltage and before all other connections have been made.
- Do not cover any vents and make sure that there is a space of several centimeters around the unit for ventilation.

Installation of counter weight

1. Slide in the counter weight (3) completely into the rear of the tone arm until it reach the end · turn it clockwise until it click with pit inside.
2. Twist the counter weight clockwise & backward until it reach the white inner line as below figure.
3. Twist the counter marking until it reach position " 0 ". The pressure at the position " 0 " at the white line is 3 grams.
4. Rotate the counter weight anti-clockwise & inward for a whole turn, it means when reaching " 0 " again, it will increase for 1 gram. It means that the press will reach 4 grams after turning for one turn inward, 5 grams after turning for two turns inward.
5. To reduce the press, rotate the counter weight clockwise and backward for a whole turn to reduce the press for 1 gram.
6. Keep rotating the counter until it reaches the appropriate working pressure.

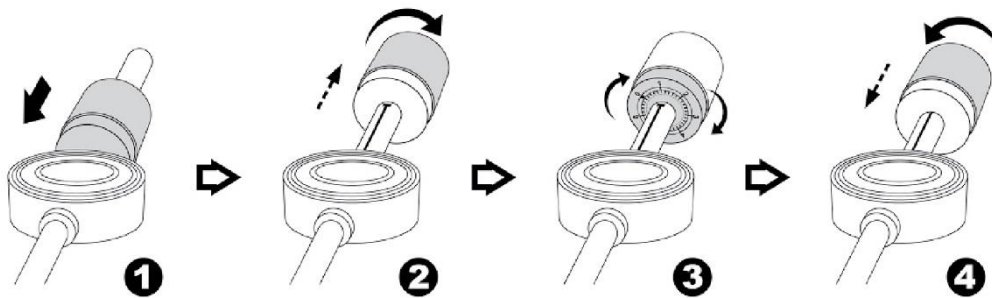

Remark : the working pressure of the provided stylus is from the range 4 – 6 grams. According to the cartridge manufacturer. All stylus has its own working pressure and please refer to the specification respectively.

Connection and general operation

1. Connect mains plug to a suitable wall socket.
2. Press the power button (14) once to turn on the unit, the function LED indicators (Phono/Bluetooth/USB) will light up.
3. Press the Function button (15) to select the desire function.
4. **Normally the sequence of the function mode is: Phono → USB → Bluetooth receiver**



And the Bluetooth transmitter function is activated at the same time during both Phono and USB modes.

Phono mode: Phono LED indicator (19, red) is light up and Bluetooth LED indicator (21, blue) is flashing.

USB mode: USB LED indicator (23, red) is light up and Bluetooth LED indicator (21, blue) is flashing.

Bluetooth receiver mode: only the Bluetooth LED indicator (21, blue) is flashing

5. Your system is now ready to operate. Please refer to the Operations section of this Manual for details.

Line out connection

You can connect the system to your own hi-fi system by connecting the line out socket (25) to the auxiliary input socket with a RCA cable.

OPERATIONS

Stereo phonograph operation

Please Note - Before Use

- Remove the stylus protector.
- Make sure that the tone arm is unlocked and free to move from the tone arm rest prior to operating. Lock the tone arm again when not in use.
- Press the power button (14) once to turn on the unit. Then press the Function button (15) repeatedly until the Phono LED indicator (19) is light up in Red color meaning it's in Phono mode.

1. Raise the turntable dust cover.
2. Place the record on the platter (use the 45 RPM record adaptor if you are playing 45 RPM records).
3. Set the speed selector (6) to the proper position for the record you are playing.
4. Set the cueing lever (5) to the up position.
5. Lift the tone arm from the rest and slowly move it to the record side. The platter will start to rotate and position the tone arm over the desired position of the record.
6. Pull down the cueing lever (5). The tone arm will come slowly on the record and start playback.
7. Press and hold the volume +/- (16) to adjust the volume level.
8. To stop manually, lift the tone arm from the record and return to the rest.

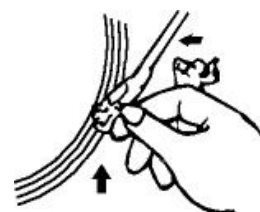

Play suspension

Set the cueing lever (5) to the up position will lift up the tone arm and then stop playback temporarily

Remark :

- This turntable system is using a magnetic cartridge system and user must replace the same type of cartridge to avoid malfunction of the unit.

Speed alignment using the Pitch adjustment

The pitch adjust control (4) is made adjust the turntable speed lightly. To check if the speed of a record that is playing is correct, and if it needs to be adjusted, do the following:

- The upper one is for $33\frac{1}{3}$ rpm
- The middle line is for 45 rpm
- During playback of for instance a 45rpm record, look at the appropriate strip of strobe calibration dots on the edge of the turntable platter under indoor lights.
- If the strobe dots appear to be flowing to the right, it means the platter is revolving slower than the rated speed. Slowly turn the Pitch Control (4) in the + direction.
- If the strobe dots appear to be flowing to the left, it means the platter is revolving faster than the rated speed. Slowly turn the Pitch Control (4) in the - direction.
- Make small adjustments with the Pitch Control until the strobe dots appear to be stationary without moving left or right.

Playback of MP3 song via USB storage media

Connecting

The system is able to decode and playback all MP3 file which stored in the memory media with USB connecting port. Plug in the USB pen driver to the slot.

Connecting the USB upside down or backwards could damage the audio system or the storage media (USB thumb drive). Check to be sure the direction is correct before connection.

- 1) Plug-in the USB plug and make sure it going into completely to the USB socket. Insert straight without bend
- 2) Press the power button (14) once to turn on the unit.
- 3) Then press the Function button (15) repeatedly until the USB LED indicator (23) is light up in Red color meaning it's in USB mode.
- 4) The system will start reading the storage media after connecting and start playback automatically. The Play / Pause LED indicator display (13) will light up in red color.

● Pause / Play mode

1. To interrupt, press the Play/Pause/Stop button (12) once, the playing time will be freeze and the Play LED indicator display (13) will be flashing in red color. Press again to resume normal playback.

● STOP MODE ■

1. Press and hold the Play/Pause/Stop button (12) for about 2-3 second during play or pause mode, system will go to stop mode and the Play LED indicator display (13) will be turned off.

● Skip track (skip up ► OR skip down ◄)

1. During play or pause mode, if Skip up button (16) is pressed once. It will go to next track and will remain in play or pause mode.
2. Alternatively, if press skip down button (16) once, it will go to the previous track and remain in play or pause mode.

● Folder up control

1. Press Folder button (26), the folder no. will goes up
2. Press Skip up or Skip down button (16) to select track
3. When the desired track is being selected, press the Play/Pause button (12) to start playback.

Remark

- MP3 track format requirement: MP3 bit rate : 32 kbps~256 kbps
- The system can detect and read the file under MP3 and format only though the USB port
- **USB port does not support connection with USB extension cable and is not designed for communication with computer directly**
- **If connect the system to MP3 player via the USB socket, due to variances in MP3 encoding format, some MP3 player may not be able to play via the USB socket. This is not a malfunction of the system.**

● Repeat/Random mode

Press the Play mode button (20) before or during playback, Repeat a single track/a single folder/all tracks, or Random play will be performed. The detailed operation is as per below table:

Action (Playmode button)	Play mode	Status of the REPEAT/RANDOM LED indicator
Press once	Repeat 1 track	REPEAT LED indicator (18) – flashing once every 2 seconds
Press 2 nd time	Repeat single folder	REPEAT LED indicator (18) – flashing twice every second
Press 3 rd time	Repeat All tracks	REPEAT LED indicator (18) – lights up
Press 4 th time	Random play	REPEAT LED indicator (22) – lights up
Press 5 th time	Off mode	No LED

● Repeat play

You can listen the desired tracks or folder or all track repeatedly by this function.

- **Random play**

You can listen all the tracks or folder in a random order by this function

Removing of USB

To remove the USB, turn off the power or switch the function mode to phono or Bluetooth receiver mode first and un-plug it by pulling out the USB socket directly.

BTT - BLUETOOTH TRANSMISSION & MUSIC STREAMING

Pairing the Record Player with an external Bluetooth Speaker system

Although this unit is supplied with two built-in speakers, it also has a **built-in Bluetooth Transmitter (BTT)**, which gives you the option to **play your records / songs from USB and listen to them wirelessly through an external Bluetooth speaker system instead.**

This can only be done if the **external speaker has a built-in Bluetooth Receiver.** The range is approximately 10 metres.

1. Switch on your external Bluetooth speaker/speaker system first.
2. Press the power button (14) to turn on the unit and operates under Phono mode or USB mode. The Bluetooth LED indicator (21) is flashing meaning it's searching for external Bluetooth speaker system to pair.
3. Once connected to the external Bluetooth speaker system, the Bluetooth LED indicator (21) will lights steadily.
 - Note: It may take for about one minute for the first connection. This will be shorter for the second connection (if using the same Bluetooth speaker) - this is normal for this unit.
4. Starts playback of your records / songs from USB:
 - **Play your records:** Follow the instructions in Phono operation section on how to play a record.
 - **Play music from USB:** Follow the instructions in Playback of MP3 song via USB storage media section on how to connect your USB and select the desired song
 - You can now enjoy your records from the record player OR the songs from the USB to your external Bluetooth speaker(s) via wirelessly streaming – press and hold the Volume +/- buttons (16) as required also on the speaker.
 - The sound from the unit's built-in speaker will be cut off automatically
5. If pairing is unsuccessful, press the BTT function button (8) on the main unit once to disconnect and restart the searching again. Then switch your Bluetooth speaker off and on again for re-connection.
6. If you want to pair with a different Bluetooth speaker system, press the BTT function button (8) on the main unit once to disconnect, then make sure you switch the previously connected Bluetooth speaker off and the Bluetooth transmitter will return to Standby mode.
7. Switch on the other Bluetooth speaker/speaker system you want to connect to – the record player will search and connect to the alternative Bluetooth speaker/speaker system. Then play your record / USB and stream the music wirelessly.

By default, the Bluetooth LED indicator light (21) will only light up when connection is successful, and will be flashing during connection process. This is normal.

Notes:

- If no Bluetooth speaker system has been detected, or switched on, or it is not within range, the music will play through the connected stereo speakers of the system.
- Refer to the instruction manual of the external Bluetooth speaker/speaker system you are using as the operation will vary from model to model.
- Remember to turn off the unit when you have finished listening and make sure the Tone arm is locked again.
- Don't forget to switch off the power of your external Bluetooth speaker as well.
- With the tone arm in the rest position, the unit goes into Bluetooth Receiver mode and activates the '**BT**' indicator light.

Bluetooth Receiver Operation

This unit has built-in speakers. It also has a built-in Bluetooth Receiver which allows you to play music from an external source through this system's connected stereo speakers.

1. Press the power button (14) once to turn on the unit. Then press the Function button (15) until only the Bluetooth LED indicator (21) is flashing in blue color meaning it's in Bluetooth pairing mode. **And the**

Phono LED indicator (19) and USB LED indicator (23) are off.

- **Normally the sequence of the function mode is: Phono → USB → Bluetooth receiver**
- 2. Turn on the Bluetooth function of the device you want to link to and enable the search or scan function to find the system.
- 3. Select "TT-930E" from the device list when it appears on your device screen.
- 4. After successfully pairing the unit with your Bluetooth device, The Bluetooth LED indicator (21) will stop flashing and remain lit.
- 5. If you want to pair (link) the unit with another Bluetooth device, press and hold the Play/Pause/Stop button (12) to disconnect and restart the searching again. The Bluetooth LED indicator (19) will flash again meaning it is in Pairing/Discoverable mode. Repeat steps 2 to 4.
- 6. Now you can play music from your Bluetooth device wirelessly to the unit:
 - Select your favorite song, press the Play/Pause on your Bluetooth device or the Play/Pause/Stop button (12) on the unit to play.
 - Press the Skip up or Skip down button (16) to select the Next or Previous track.
 - Adjust the volume control of your Bluetooth device or the hi-fi system until you reach a comfortable listening level.

Notes :

1. Refer to the manual of your cell phone, tablet PC, computer or other Bluetooth enabled devices for Bluetooth operation since it may vary from model to model.
2. If your Bluetooth enabled device does not support A2DP profile, it will not play the music through the speaker, even if paired (linked).
3. Remember to turn off the unit when you have finished listening,
4. Don't forget to switch off the power of your Bluetooth device as well.
5. The REPEAT / RANDOM FUNCTION do not apply to Bluetooth operation.

Encode from Phono/Bluetooth to USB into MP3 file

The system is able to encode the Phono or Bluetooth into MP3 format and recording at memory media with USB connecting port. Make sure there is sufficient space available on the USB pen drive for encoding.

A) Encode from a Record

- 1) Press the Power button (14) once to turn on the unit. Then press the Function button (15) repeatedly until the Phono LED indicator (19) is light up in Red color meaning it's in Phono mode.
- 2) Insert a USB pen drive into the USB port and press the Record button (10). The Record LED indicator (11) will light up first and then start flashing meaning recording is in progress.
- 3) Following the Phono operation section to start playback phono for the track which you want to record.
- 4) After finish the recoding, press the Record button (10) again and the Record LED indicator (11) will turn off and return to Phono mode.

B) Encode from Bluetooth

- 1) Follow the Bluetooth Receiver Operation to connect the unit with the Bluetooth device and select the song(s) or playlist that you wish to record. Ensure the music is in pause/stop mode before recording starts.
- 2) Insert a USB pen drive into the USB port.
- 3) Press the Record button (10) once, the Record LED indicator (11) will start flashing meaning recording is in progress.
- 4) Start playback of the song(s) or playlist.
- 5) After finish the recoding, press the Record button (10) again and the Record LED indicator (11) will turn off and return to Bluetooth mode.

Remark:-

- The recording speed is 1:1 and according to the actual plying time.
- The system will create an " audio " folder and store the encoded tracks in it.
- The encoding format is preset at MP3, bit rate : 192 kbps, sampling rate : 44.1kHz.
- No song title will be recorded during encoding mode

C) Track separation

You can divide the recording music from phono / Bluetooth to USB track by track during encoding. Every time when press the REC  (track separation) button (9) once during encoding from phono / Bluetooth to USB, the Record LED indicator (11) will light up first and then start flashing meaning the system has ended the previous recorded track and generate a new track and continue the recording.

SPECIFICATIONS

DC: 14V  1.5A

Bluetooth

Maximum communication range: Line of sight approx. 10m (30 feet)

WARRANTY CARD

Dear Customer, thank you for choosing SeeYing.
Wish our product will give you a nice classic music experience.
Please keep this card for product warranty!
Any questions feel free to contact:
seeyinguserservice@outlook.com

SEEYING		
Warranty Card		
Model Number	Date of Purchase	QA PASSED
Customer	Dealer	
Name	Name and Address	
Address		

Benefits for contacting us:

- ① You'll get a reply in 12 working hours.
- ② You'll get professional technical support.
- ③ If you are satisfied with our product, please leave your honest review for us and we will give you a surprise!



Contact us directly for any further information or any question.
We are able to solve all your problems and it's our pleasure
to provide best customer service for you!

Feel free to contact us at:
seeyinguserservice@outlook.com

Warning ..atement

This device complies with part 15 of the FCC Rules. Operation is subject to the following two conditions: (1) This device may not cause harmful interference, and (2) this device must accept any interference received, including interference that may cause undesired operation.

Any Changes or modifications not expressly approved by the party responsible for compliance could void the user's authority to operate the equipment.

Note: This equipment has been tested and found to comply with the limits for a Class B digital device, pursuant to part 15 of the FCC Rules. These limits are designed to provide reasonable protection against harmful interference in a residential installation.

This equipment generates uses and can radiate radio frequency energy and, if not installed and used in accordance with the instructions, may cause harmful interference to radio communications. However, there is no guarantee that interference will not occur in a particular installation. If this equipment does cause harmful interference to radio or television reception, which can be determined by turning the equipment off and on, the user is encouraged to try to correct the interference by one or more of the following measures:

- Reorient or relocate the receiving antenna.
- Increase the separation between the equipment and receiver.
- Connect the equipment into an outlet on a circuit different from that to which the receiver is connected.
- Consult the dealer or an experienced radio/TV technician for help.