

User Manual















Product Name: Handheld Gimbal

Model: AIR, AIR-360, AIRCORSS

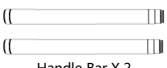
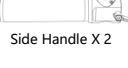
Brand: MOZA

Manufacture: Gudsen Technology Co., LTD

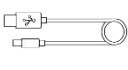
A Packing List

 Gimbal x 1	 Handgrip x 1	 26350 Battery X3	 Charger X 1
 Tripod (Optional)	 Wireless Thumb Controller (Optional)	 Lens Support X 1	 Lens Support Screw X1
 Handle Bar X 2	 Side Handle X 2	 Handle Clamp X 1	 Tool Bag
 Control Cable X 3	 USBCable X 1	 AC Cable (Adapter) X 1	 User Manual X 1

BMOZA Air

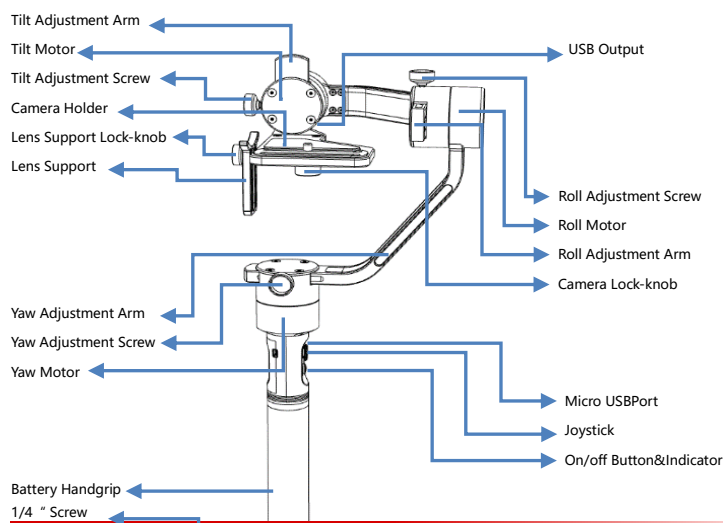

Buttons&Ports

On/Off button : **Single Press**: Start/Stop recording **Double Press**: Undefined
Triple Press: Re-center **Long Press**: Turn on/off
Joystick : **Up\Down\Left\Right** : Control the gimbal movements
Single Press: Yaw-follow **Double Press**: Yaw-tilt follow **Triple Press**: All-locked
Long Press: Standby **Single Press in Standby Mode**: Awaken the gimbal
USB Input : Adjust parameters ; Upgrade firmware **USB Output** : Control camera recording

DSet up the MOZA Air

1. Charging Batteries.

Battery charger comes with 4 slots, each slot packs one piece of 26350 battery to charge at the same time. Make sure the positive terminal is facing the charger indicator.
 Charging starts when indicator changes to red after installation, the charger indicator Turn to green when the battery is full of electricity.



2. Install Batteries.

Insert three 26350 batteries into the handgrip. Make sure the positive terminal is facing upwards.
 Then screw the handgrip to the gimbal.



3. Mount the Camera.

Lay the gimbal horizontal, resting on it the roll motor as shown. Place the camera on the camera mount platform.
 Align the camera's 1/4" mount by passing the 1/4" camera lock-knob through the camera mount platform. Tighten the camera lock-knob to secure the camera.
 Smaller cameras should choose the closest track to the tilt motor such as A7s. For larger bodied cameras the further track from the tilt motor, such as Canon 5D.

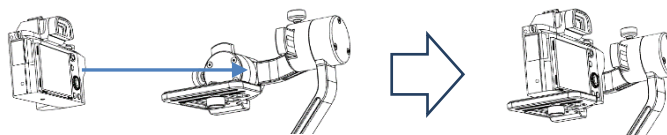

4. Attaching the Dual Handle.

Insert the handle bar into the side handles and tighten the lock-screw on each side. Loosen the lock-screw in the middle of the handle bar. Attach the handgrip to the handle clamp and then adjust it properly, tighten the lock-screw.



5. How to connect Camera Control Cables.

Connect the camera to the Mini-USB port on the tilt motor with the control cable. Plug the L-shaped end of the control cable into the USB output port, and plug the other end into the camera USB port or the shutter port. Please make sure the gimbal motor is not blocked by the control cable. Press the On/Off button on the handgrip to start or stop recording.



E Adjust Balance

(1) Put the MOZA Air upright, lock the yaw axis and roll axis. Rotate the tilt axis with your hand so that the camera lens faces downwards.

If the camera lens rotates forward, loosen the lock-screw on the tilt adjustment arm, move the tilt arm backward till the lens is downward and not rotating due to the gravity. If the camera lens rotates backward, loosen the lock-screw on the tilt adjustment arm, move the tilt arm forward till the lens is downward and cannot rotate.

Tighten the lock-screw after tilt balance is finished.

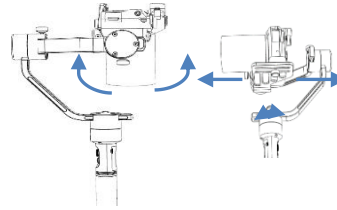

(2) Move the camera forward or backward

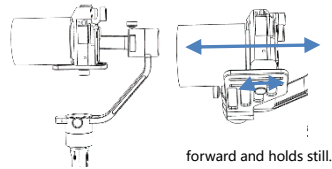

If the camera lens tilts up, loosen the camera lock-knob, move the camera forward till the camera lens holds.

If the camera lens tilts down, loosen the camera lock-knob, move the camera backward till the camera lens is forward and holds still.

2. Balance the Yaw Axis.

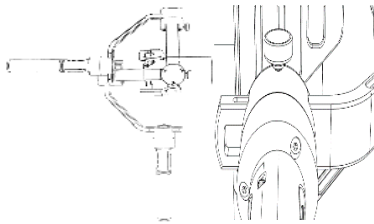

Hold the MOZA Air in the way as shown in the picture below. Then release the yaw arm.

If the roll motor descends and the camera ascends, loosen the lock-screw in the yaw axis adjustment arm and move the yaw arm towards the camera till the yaw axis holds still.

If the roll motor ascends and the camera descends, loosen the lock and move the yaw arm towards the roll motor till the yaw axis holds still. After the yaw axis is properly balanced, tighten the

lock-screw.

F Changing Operating Modes

Underslung Mode: Rotate the handgrip around the roll motor till 180 degrees above the camera. If the roll axis adjustment arm is too far out to the right, the tilt motor will not rotate. The gimbal may shake when rotating to 90 degrees. Do not stay too long in the 90-degree rotation.

Flashlight Mode: Rotate the handgrip around the tilt motor by 90 degrees. Switching into the flashlight mode may fail if the tilt axis adjustment arm is excessively upward.

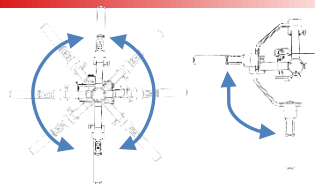

G Wireless Thumb Controller (Optional)

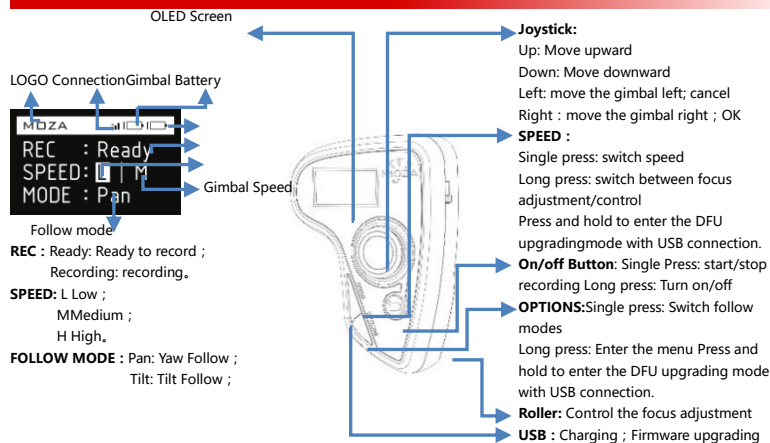

Functions :

- Pair : Pairing is necessary when you change the wireless thumb controller, gimbal or upgrade the firmware. Long press 'OPTIONS' to enter the menu. Then choose 'Pair' and move the joystick rightwards to enter the secondary menu. Move the joystick downwards to choose the 'YES' option, and move the joystick rightwards again to enter the Pairing mode. The interface of 'Pairing' will appear. Then turn on MOZA Air gimbal, The screen of the thumb controller shows 'OK' in about 3 seconds.
- Camera : Choose the camera type you will use with the gimbal to control the camera start/stop recording.
- Profile : There are 4 sets of parameters are optional for different camera and lens in different weights.
- Follow Speed: Gimbal movement speed along with the operator. Three follow modes are available.
- Power : Motor torque.
- Gyro Calibrate : Calibrate the Gyro. Turn off the motor before calibration.
- Habits : Set the motor and direction controlled by joystick, and time shown in the screen.
- Motor : Turn on or off the motor.
- Version : View the current firmware version of the wireless thumb controller.

HAPP & GUI

APP : (Only for iOS)

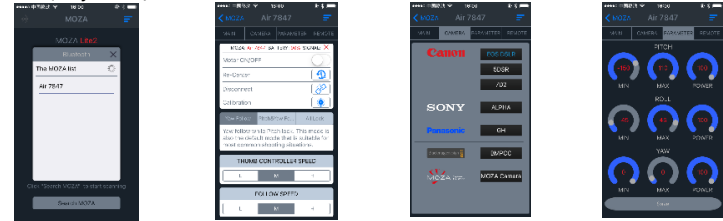

Search for your MOZA Air status. Set control. Choose camera type. Change parameters. Device speed and calibrate Gyro.

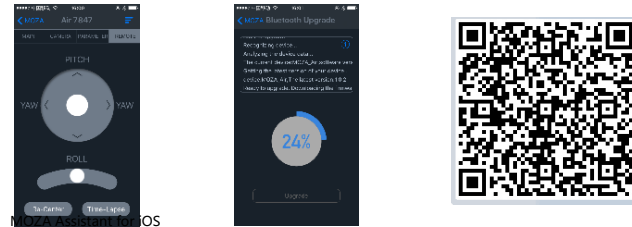

Control the gimbal movements. Firmware upgrade.

GUI : (Currently supports Window & Mac OS system)

Download the file and install the driver. Turn on the MOZA Air and connect it to computer to enter the interface for parameter adjustment.



Gimbal Interface: adjust Endpoint range. Control interface : adjust control speed and parameters of dead angle. Calibrate interface: calibrate Gyro motor torque and follow mode.

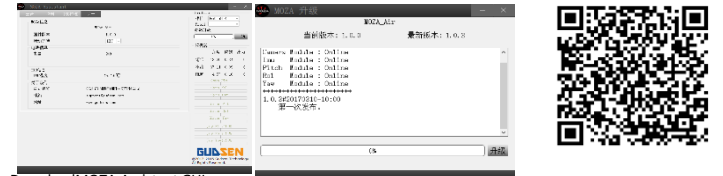

Download MOZA Assistant GUI

Info Interface: Check info about version and battery level. Press the joystick button to turn MOZA Air on. Enter the firmware upgrading mode. Then connect

Upgrade Firmware :

- MOZA Assistant Software :**
- Press the joystick to turn on MOZA Air and enter the firmware upgrading mode. The indicator will blink and the motors will power off. Connect the gimbal to computer with USB cable and then launch GUI. GUI will automatically recognize MOZA Air's status and enter the firmware upgrading interface. Connect to the network and click "Upgrade". The GUI will automatically download the latest firmware and rewrite it to the MOZA Air. After upgrading is 100%. Disconnect the USB cable and restart the MOZA Air.

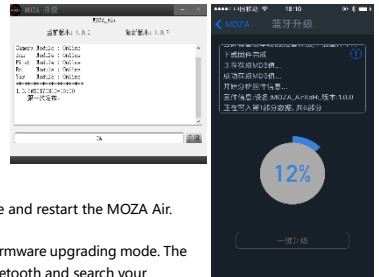

MOZA Assistant App :

Press the joystick to turn MOZA Air on and enter the firmware upgrading mode. The indicator will blink and the motors power will off. Turn on Bluetooth and search your MOZA device to connect. The MOZA Assistant App will recognize MOZA Air's status and enter the firmware upgrading interface. Make sure network is connected and click "Upgrade". The App will automatically download the latest firmware and rewrite it to the MOZA Air. After the upgrading is 100%, disconnect and restart the MOZA Air. It can take around 20 minutes to upgrade firmware on the mobile phone.

Sensor Calibration :

Use GUI to calibrate sensor. Click "Motor" to turn off motors. Place the gimbal on a sturdy vibration-free surface. Then click "Simple Gyro Calibration". The computer screen will show "success" after the calibration is finished, then restart MOZA Air.

Use App to calibrate sensor. Click "Motor" to turn off motors in the APP. Place the gimbal on a sturdy vibration-free surface. Click "Sensor Calibration">Gyro Calibration>Start buttons step in step. Disconnect after the screen shows "Back", then restart MOZA Air.

Use the Wireless Thumb Controller to calibrate sensor. Place the gimbal on a sturdy vibration-free surface. Click "Gyro Calibrate>Yes" buttons. Once the screen shows "success", restart the MOZA Air.

JSpecs

Gimbal	Battery	Wireless Thumb Controller
Weight:1100g (without battery)	Type : Li-ion	Weight :100g
Dimensions:336*115*40mm	Model : 26350	Battery Capacity:600mAh
Max Payload : 2500g	Capacity : 2000mAh	Battery Voltage:3.7V
Tilt Rotation Range : 360°	Output Voltage : 4.2V (max)	Working Current: 50mA
Roll Rotation Range : 360°	Output Current : 2A (max)	Rest Current: 10mA
Yaw Rotation Range : 360°	Charger	Standby Time: 24h
Working Voltage : 10—15V	Input Voltage : 110~220V AC	Wireless Type: 2.4G
Dynamic Current : 200mA	Output Voltage : 4.2V	Control Range:50M
Static Current : 100mA	Output Current : 1000mA X 4 / 500mA X 4	Charging Voltage: 5V
Battery Life : ≥6hrs	Charging Time : 3hrs	Charging Time: 2h
Bluetooth : Bluetooth 4.0		
valid range: 5m		
USB Input : Micro USB 2.0		

KAAfter-sales Policy

The gimbal and charger are covered by a 12-month warranty. The motor and battery come with a 3-month warranty.

The one-year limited warranty does not apply to consumable parts such as the user manual, USB cables, and outer box. Shipping costs are not covered. Check the detailed warranty policy for your region on www.gudsen.com

Exchange & Repair

If the product has manufacturing defects within 15 calendar days of purchasing the product can be exchanged. The replacement applies only to the gimbal. Other accessories without qualifying issues are not covered.

Warranty repair service will not be provided if the conditions are:

1. Warranty expired;
2. No legal proof of purchase, receipt or invoice is not provided;
3. Product labels, serial numbers, waterproof marks, etc. show signs of tampering or alteration.
4. Any damage of the product is caused by unauthorized use or modification of the product.
5. Damage that is caused to the product by uncontrollable external factors.
6. Damage that is caused by improper usage and maintenance.

LCContact Us

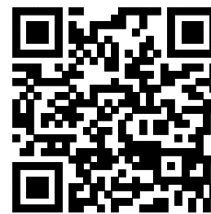

TwitterFacebookInstagram

E-mail : SUPPORT@GUDSEN.COM

Website : WWW.GUDSEN.COM

FCC Caution.

This device complies with part 15 of the FCC Rules. Operation is subject to the following two conditions: (1) This device may not cause harmful interference, and (2) this device must accept any interference received, including interference that may cause undesired operation.

Any Changes or modifications not expressly approved by the party responsible for compliance could void the user's authority to operate the equipment.

Note: This equipment has been tested and found to comply with the limits for a Class B digital device, pursuant to part 15 of the FCC Rules. These limits are designed to provide reasonable protection against harmful interference in a residential installation. This equipment generates uses and can radiate radio frequency energy and, if not installed and used in accordance with the instructions, may cause harmful interference to radio communications. However, there is no guarantee that interference will not occur in a particular installation. If this equipment does cause harmful interference to radio or television reception, which can be determined by turning the equipment off and on, the user is encouraged to try to correct the interference by one or more of the following measures:

- Reorient or relocate the receiving antenna.
- Increase the separation between the equipment and receiver.
- Connect the equipment into an outlet on a circuit different from that to which the receiver is connected.
- Consult the dealer or an experienced radio/TV technician for help.

The device has been evaluated to meet general RF exposure requirement. The device can be used in portable exposure condition without restriction.