



TEST REPORT

No. I19N00406-RF-GSM

for

DAIMLER AG

CTPDIN

Model Name: CTP2019

FCC ID: 2AMIOCTP4465960

with

Hardware Version: A 000 446 5960

Software Version: 126.200.800

Issued Date: 2019-04-19

Note:

The test results in this test report relate only to the devices specified in this report. This report shall not be reproduced except in full without the written approval of SAICT.

Test Laboratory:

Designation Number: CN1210

SAICT, Shenzhen Academy of Information and Communications Technology

Building G, Shenzhen International Innovation Center, No.1006 Shennan Road, Futian District, Shenzhen, Guangdong, P. R. China 518026.

Tel: +86(0)755-33322000, Fax: +86(0)755-33322001

Email: yewu@caict.ac.cn, website: www.cszit.com

REPORT HISTORY

Report Number	Revision	Description	Issue Date
I19N00406-RF-GSM	Rev.0	1st edition	2019-04-19

CONTENTS

1. TEST LABORATORY	4
1.1. TESTING LOCATION	4
1.2. TESTING ENVIRONMENT	4
1.3. PROJECT DATA.....	4
1.4. SIGNATURE	4
2. CLIENT INFORMATION	5
2.1. APPLICANT INFORMATION.....	5
2.2. MANUFACTURER INFORMATION	5
3. EQUIPMENT UNDER TEST (EUT) AND ANCILLARY EQUIPMENT (AE)	6
3.1. ABOUT EUT	6
3.2. INTERNAL IDENTIFICATION OF EUT USED DURING THE TEST	6
3.3. INTERNAL IDENTIFICATION OF AE USED DURING THE TEST.....	6
3.4. GENERAL DESCRIPTION	6
4. REFERENCE DOCUMENTS	7
4.1. REFERENCE DOCUMENTS FOR TESTING	7
5. LABORATORY ENVIRONMENT	8
6. SUMMARY OF TEST RESULTS.....	9
7. TEST EQUIPMENTS UTILIZED.....	10
ANNEX A: MEASUREMENT RESULTS	11
A.1 OUTPUT POWER	11
A.2 FIELD STRENGTH OF SPURIOUS RADIATION	19
A.3 FREQUENCY STABILITY	27
A.4 OCCUPIED BANDWIDTH.....	30
A.5 EMISSION BANDWIDTH.....	39
A.6 BAND EDGE COMPLIANCE.....	47
A.7 CONDUCTED SPURIOUS EMISSION	52

1. Test Laboratory

1.1. Testing Location

Company Name: Shenzhen Academy of Information and Communications
Technology
Address: Building G, Shenzhen International Innovation Center, No.1006
Shennan Road, Futian District, Shenzhen, Guangdong, P. R. China
Postal Code: 518026
Telephone: +86(0)755-33322000
Fax: +86(0)755-33322001

1.2. Testing Environment

Normal Temperature: 15-35°C
Relative Humidity: 20-75%

1.3. Project data

Testing Start Date: 2019-03-04
Testing End Date: 2019-03-14

1.4. Signature

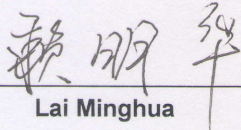

Lai Minghua

(Prepared this test report)

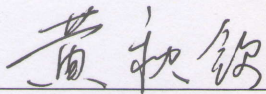

Huang Qiuqin

(Reviewed this test report)

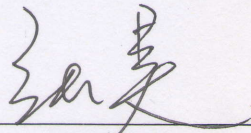

Zhang Hao

(Approved this test report)

2. Client Information

2.1. Applicant Information

Company Name: DAIMLER AG
Address /Post: Mercedesstraße 137, 70327 Stuttgart, Germany
Contact Person: Jan Waldmann
Contact Email jan.waldmann@daimler.com
Telephone: +49-711-17-40099
Fax: +49-711-3052-148458

2.2. Manufacturer Information

Company Name: Bosch Car Multimedia Portugal, S.A.
Address /Post: Rua Max Grundig, 35 – Lomar, 4705-820 Braga, Portugal
Contact Person: Eliseu Vieira
Contact Email Eliseu.Vieira@pt.bosch.com
Telephone: +351(253)30-6307
Fax: /

3. Equipment Under Test (EUT) and Ancillary Equipment (AE)

3.1. About EUT

Description	CTPDIN
Model Name	CTP2019
FCC ID	2AMIOCTP4465960
Frequency Bands	GSM850/1900
Extreme vol. Limits	19.2VDC to 28.8VDC (nominal: 24VDC)
Condition of EUT as received	No abnormality in appearance

3.2. Internal Identification of EUT used during the test

EUT ID*	IMEI	HW Version	SW Version	Sample Arrival Date
UT01aa	352255061162925	A 000 446 5960	126.200.800	2019-03-04

*EUT ID: is used to identify the test sample in the lab internally.

3.3. Internal Identification of AE used during the test

AE ID*	Description	SN
AE1	GNSS antenna	A005 820 3075
AE2	CN Antenna	A002 827 2201
AE3	WiFi Antenna	A177 905 2902
AE4	Power Cable	/
AE5	USB Cable	/

*AE ID: is used to identify the test sample in the lab internally.

3.4. General Description

The Equipment Under Test (EUT) is a model LTE-FDD telematic platform with external antenna. It consists of normal options: power line, RF cable and external antenna. Manual and specifications of the EUT were provided to fulfil the test.

4. Reference Documents

4.1. Reference Documents for testing

The following documents listed in this section are referred for testing.

Reference	Title	Version
FCC Part 22	PUBLIC MOBILE SERVICES	10-1-17 Edition
FCC Part 24	PERSONAL COMMUNICATIONS SERVICES	10-1-17 Edition
FCC Part 2	FREQUENCY ALLOCATIONS AND RADIO TREATY MATTERS; GENERAL RULES AND REGULATIONS	10-1-17 Edition
ANSI/TIA-603-E	Land Mobile FM or PM Communications Equipment Measurement and Performance Standards	2016

5. LABORATORY ENVIRONMENT

Control room / conducted chamber did not exceed following limits along the RF testing:

Temperature	Min. = 15 °C, Max. = 35 °C
Relative humidity	Min. = 20 %, Max. = 80 %
Shielding effectiveness	> 110 dB
Electrical insulation	> 2 MΩ
Ground system resistance	< 0.5 Ω

Fully-anechoic chamber did not exceed following limits along the EMC testing

Temperature	Min. = 15 °C, Max. = 35 °C
Relative humidity	Min. = 15 %, Max. = 75 %
Shielding effectiveness	0.014MHz-1MHz > 60 dB; 1MHz-18000MHz > 90 dB
Electrical insulation	> 2MΩ
Ground system resistance	< 4 Ω
Voltage Standing Wave Ratio (VSWR)	≤ 6 dB, from 1 to 18 GHz, 3 m distance
Uniformity of field strength	Between 0 and 6 dB, from 80 to 6000 MHz

6. SUMMARY OF TEST RESULTS

Abbreviations used in this clause:		
Verdict Column	P	Pass
	F	Fail
	NA	Not applicable
	NM	Not measured
Location Column	A/B/C/D	The test is performed in test location A, B, C or D which are described in section 1.1 of this report

GSM850

Items	List	Clause in FCC rules	Section in this report	Verdict
1	Output Power	2.1046/22.913	A.1	P
2	Field Strength of Spurious Radiation	2.1053/22.917	A.2	P
3	Frequency Stability	2.1055/22.355	A.3	P
4	Occupied Bandwidth	2.1049/22.917	A.4	P
5	Emission Bandwidth	2.1049/22.917	A.5	P
6	Band Edge Compliance	2.1051/22.917	A.6	P
7	Conducted Spurious Emission	2.1051/22.917	A.7	P

PCS1900

Items	List	Clause in FCC rules	Section in this report	Verdict
1	Output Power	2.1046/24.232	A.1	P
2	Field Strength of Spurious Radiation	2.1053/24.238	A.2	P
3	Frequency Stability	2.1055/24.235	A.3	P
4	Occupied Bandwidth	2.1049/24.238	A.4	P
5	Emission Bandwidth	2.1049/24.238	A.5	P
6	Band Edge Compliance	2.1051/24.238	A.6	P
7	Conducted Spurious Emission	2.1051/24.238	A.7	P

7. Test Equipments Utilized

NO.	Description	TYPE	Manufacture	series number	CAL DUE DATE
1	Test Receiver	ESR7	R&S	101676	2019-11-28
2	BiLog Antenna	3142E	ETS	00224831	2021-05-17
3	Horn Antenna	3117	ETS-lindgren	00066577	2022-04-02
4	Horn Antenna	QSH-SL-18 -26-S-20	Q-par	17013	2020-01-15
5	Antenna	BBHA 9120D	Schwarzbeck	1593	2019-12-11
6	Antenna	VUBA 9117	Schwarzbeck	207	2020-07-16
7	Antenna	QWH-SL-18 -40-K-SG	Q-par	15979	2020-01-16
8	preamplifier	83017A	Agilent	MY39501110	/
9	Signal Generator	SMB100A	R&S	179725	2019-11-28
10	Fully Anechoic Chamber	FACT3-2.0	ETS-Lindgren	1285	2020-07-20
11	Spectrum Analyzer	FSV40	R&S	101192	2019-05-21
12	Universal Radio Communication Tester	CMU200	R&S	114545	2019-05-17
13	Universal Radio Communication Tester	CMU200	R&S	123210	2019-12-13
14	Spectrum Analyzer	FSU	R&S	200679	2019-12-13
15	Temperature Chamber	SH-241	ESPECs	92007516	2019-11-13
16	DC Power Supply	U3606A	Agilent Technologies	MY50450012	2019-11-13

Test software

Item	Name	Vesion
Radiated	EMC32	Version 10.01.00

ANNEX A: MEASUREMENT RESULTS

A.1 OUTPUT POWER

Reference

FCC: CFR Part 2.1046, 22.913, 24.232

A.1.1 Summary

During the process of testing, the EUT was controlled via Rhode & Schwarz Digital Radio Communication tester (CMU-200) to ensure max power transmission and proper modulation.

This result contains output power and EIRP measurements for the EUT. In all cases, output power is within the specified limits.

A.1.2 Conducted

A.1.2.1 Method of Measurements

The EUT was set up for the max output power with pseudo random data modulation.

These measurements were done at 3 frequencies, 1850.2 MHz, 1880.0MHz and 1909.8MHz for PCS1900 band; 824.2MHz, 836.6MHz and 848.8MHz for GSM850 band. (bottom, middle and top of operational frequency range).

GSM850

	Power step	Nominal Peak output power (dBm)
GPRS	3	33dBm(2W)
EGPRS	6	27dBm(0.5W)

Measurement result

GPRS(GMSK,1Slot)

Frequency(MHz)	Power Step	Output power(dBm)
824.2	3	32.39
836.6	3	32.25
848.8	3	32.16

EGPRS(8PSK,1Slot)

Frequency(MHz)	Power Step	Output power(dBm)
824.2	6	26.96
836.6	6	26.98
848.8	6	27.18

Note: Expanded measurement uncertainty is $U = 0.488\text{dB}$, $k = 1.96$

PCS1900

	Power step	Nominal Peak output power (dBm)
GPRS	3	30dBm(1W)
EGPRS	5	26dBm(0.4W)

Measurement result

GPRS(GMSK,1Slot)

Frequency(MHz)	Power Step	Output power(dBm)
1850.2	3	30.32
1880.0	3	30.36
1909.8	3	29.83

EGPRS(8PSK,1Slot)

Frequency(MHz)	Power Step	Output power(dBm)
1850.2	5	25.96
1880.0	5	26.11
1909.8	5	26.08

Note: Expanded measurement uncertainty is $U = 0.488\text{dB}$, $k = 1.96$

A.1.3 Radiated

A.1.3.1 Description

This is the test for the maximum radiated power from the EUT.

Rule Part 24.232(c) specifies, "Mobile/portable stations are limited to 2 watts e.i.r.p. Peak power" and 24.232(c) specifies that "Peak transmit power must be measured over any interval of continuous transmission using instrumentation calibrated in terms of an rms-equivalent voltage."

Rule Part 22.913(a) specifies "The ERP of mobile transmitters and auxiliary test transmitters must not exceed 7 Watts."

A.1.3.2 Method of Measurement

The measurements procedures in TIA-603-E-2016 are used.

1. EUT was placed on a 1.5 meter high non-conductive stand at a 3 meter test distance from the receive antenna. A receiving antenna was placed on the antenna mast 3 meters from the EUT for emission measurements. The height of receiving antenna is 1.5m. The test setup refers to figure below. Detected emissions were maximized at each frequency by rotating the EUT through 360° and adjusting the receiving antenna polarization. The radiated emission measurements of all transmit frequencies in three channels (High, Middle, Low) were measured with peak detector.

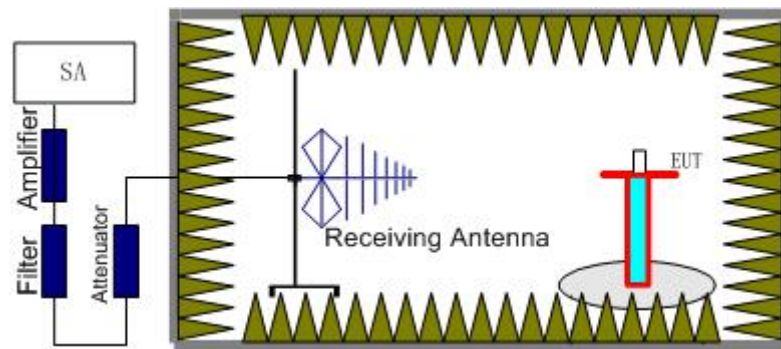

2. The EUT is then put into continuously transmitting mode at its maximum power level during the test. And the maximum value of the receiver should be recorded as (Pr). The placement of EUT and AE is shown in the figure below, what's more, The EUT was tested in two states, horizontal and vertical.as show in the attachment.

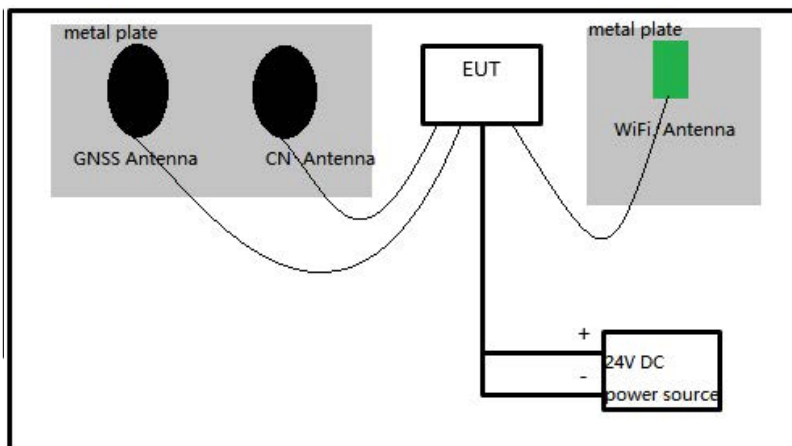

3. The EUT shall be replaced by a substitution antenna. The test setup refers to figure below.

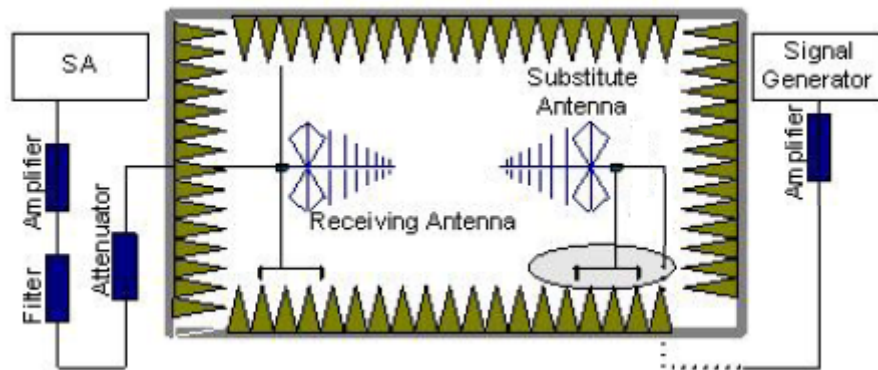

In the chamber, an substitution antenna for the frequency band of interest is placed at the reference point of the chamber. An RF Signal source for the frequency band of interest is connected to the substitution antenna with a cable that has been constructed to not interfere with the radiation pattern of the antenna. A power (P_{Mea}) is applied to the input of the substitution antenna, and adjust the level of the signal generator output until the value of the receiver reach the previously recorded (P_r). The power of signal source (P_{Mea}) is recorded. The test should be performed by rotating the test item and adjusting the receiving antenna polarization.

4. A amplifier should be connected to the Signal Source output port. And the cable should be connect between the Amplifier and the Substitute Antenna.

The cable loss (P_{cl}), the Substitute Antenna Gain(dBi) (G_a) and the Amplifier Gain (P_{Ag}) should be recorded after test.

The measurement results are obtained as described below:

$$\text{Power(EIRP)} = P_{Mea} - P_{Ag} - P_{cl} + G_a$$

5. This value is EIRP since the measurement is calibrated using an antenna of known gain (2.15 dBi) and known input power.
6. ERP can be calculated from EIRP by subtracting the gain of the dipole, $ERP = EIRP - 2.15\text{dB}$.

EUT-Horizontal

GSM 850-ERP 22.913(a)

Limits

	Power Step	Burst Peak ERP (dBm)
GSM	5	≤38.45dBm (7W)
GPRS	3	≤38.45dBm (7W)
EGPRS	6	≤38.45dBm (7W)

Measurement result

GPRS

Frequency(MHz)	P _{Mea} (dBm)	P _{cl} (dB)+ P _{Ag} (dB)	Ga Antenna Gain(dBi)	Correction (dB)	ERP(dBm)	Limit(dBm)	Polarization
824.20	-5.01	-33.60	0.28	2.15	26.72	38.45	H
836.60	-2.99	-33.50	0.25	2.15	28.61	38.45	H
848.80	-2.00	-33.50	0.21	2.15	29.57	38.45	H

EGPRS-8PSK

Frequency(MHz)	P _{Mea} (dBm)	P _{cl} (dB)+ P _{Ag} (dB)	Ga Antenna Gain(dBi)	Correction (dB)	ERP(dBm)	Limit(dBm)	Polarization
824.20	-9.19	-33.60	0.28	2.15	22.54	38.45	H
836.60	-9.75	-33.50	0.25	2.15	21.85	38.45	H
848.80	-8.34	-33.50	0.21	2.15	23.22	38.45	H

Frequency: 848.80MHz

Peak ERP(dBm)=P_{Mea}(-2.00dBm)-(P_{cl}+P_{Ag})(-33.50dB)+Ga(0.21dB)-2.15dB=29.57dBm

ANALYZER SETTINGS: RBW = VBW = 3MHz

Note: The maximum value of expanded measurement uncertainty for this test item is U =

3.34dB(30MHz-3GHz)/4.06dB(3GHz-18GHz)/4.56dB(18GHz-40GHz), k = 2

PCS1900-EIRP 24.232(c)

Limits

	Power Step	Burst Peak EIRP (dBm)
GSM	0	≤33dBm (2W)
GPRS	3	≤33dBm (2W)
EGPRS	5	≤33dBm (2W)

Measurement result

GPRS

Frequency(MHz)	P _{Mea} (dBm)	P _{cl} (dB)+ P _{Ag} (dB)	Ga Antenna Gain(dBi)	EIRP(dBm)	Limit(dBm)	Polarization
1850.20	-4.09	-29.40	0.15	25.46	33.00	H
1880.00	-1.29	-29.30	0.25	28.26	33.00	H
1909.80	-3.12	-29.30	0.35	26.53	33.00	H

EGPRS-8PSK

Frequency(MHz)	P _{Mea} (dBm)	P _{cl} (dB)+ P _{Ag} (dB)	Ga Antenna Gain(dBi)	EIRP(dBm)	Limit(dBm)	Polarization
1850.20	-4.40	-29.40	0.15	25.15	33.00	H
1880.00	-1.45	-29.30	0.25	28.10	33.00	H
1909.80	-3.38	-29.30	0.35	26.27	33.00	H

Frequency: 1880.00MHz

Peak EIRP(dBm)= P_{Mea}(-1.29dBm) -(P_{cl}+P_{Ag})(-29.30dB)+Ga (0.25dB) =28.26dBm

ANALYZER SETTINGS: RBW = VBW = 3MHz

Note: The maximum value of expanded measurement uncertainty for this test item is U = 3.34dB(30MHz-3GHz)/4.06dB(3GHz-18GHz)/4.56dB(18GHz-40GHz), k = 2

EUT- Vertical

GSM 850-ERP 22.913(a)

Limits

	Power Step	Burst Peak ERP (dBm)
GSM	5	≤38.45dBm (7W)
GPRS	3	≤38.45dBm (7W)
EGPRS	6	≤38.45dBm (7W)

Measurement result

GPRS

Frequency(MHz)	P _{Mea} (dBm)	P _{cl} (dB)+ P _{Ag} (dB)	Ga Antenna Gain(dBi)	Correction (dB)	ERP(dBm)	Limit(dBm)	Polarization
824.20	-4.01	-33.60	0.28	2.15	27.72	38.45	H
836.60	-2.99	-33.50	0.25	2.15	28.61	38.45	H
848.80	-2.00	-33.50	0.21	2.15	29.57	38.45	H

EGPRS-8PSK

Frequency(MHz)	P _{Mea} (dBm)	P _{cl} (dB)+ P _{Ag} (dB)	Ga Antenna Gain(dBi)	Correction (dB)	ERP(dBm)	Limit(dBm)	Polarization
824.20	-7.82	-33.60	0.28	2.15	23.91	38.45	H
836.60	-8.56	-33.50	0.25	2.15	23.04	38.45	H
848.80	-6.73	-33.50	0.21	2.15	24.83	38.45	H

Frequency: 848.80MHz

Peak ERP(dBm)=P_{Mea}(-2.00dBm)-(P_{cl}+P_{Ag})(-33.50dB)+Ga(0.21dB)-2.15dB=29.57dBm

ANALYZER SETTINGS: RBW = VBW = 3MHz

Note: The maximum value of expanded measurement uncertainty for this test item is U =

3.34dB(30MHz-3GHz)/4.06dB(3GHz-18GHz)/4.56dB(18GHz-40GHz), k = 2

PCS1900-EIRP 24.232(c)

Limits

	Power Step	Burst Peak EIRP (dBm)
GSM	0	≤33dBm (2W)
GPRS	3	≤33dBm (2W)
EGPRS	5	≤33dBm (2W)

Measurement result

GPRS

Frequency(MHz)	P _{Mea} (dBm)	P _{cl} (dB)+ P _{Ag} (dB)	Ga Antenna Gain(dBi)	EIRP(dBm)	Limit(dBm)	Polarization
1850.20	-3.07	-29.40	0.15	26.48	33.00	H
1880.00	-1.01	-29.30	0.25	28.54	33.00	H
1909.80	-2.30	-29.30	0.35	27.35	33.00	H

EGPRS-8PSK

Frequency(MHz)	P _{Mea} (dBm)	P _{cl} (dB)+ P _{Ag} (dB)	Ga Antenna Gain(dBi)	EIRP(dBm)	Limit(dBm)	Polarization
1850.20	-4.93	-29.40	0.15	24.62	33.00	H
1880.00	-2.14	-29.30	0.25	27.41	33.00	H
1909.80	-3.78	-29.30	0.35	25.87	33.00	H

Frequency: 1880.00MHz

Peak EIRP(dBm)= P_{Mea}(-1.01dBm) -(P_{cl}+P_{Ag})(-29.30dB)+Ga (0.25dB) =28.54dBm

ANALYZER SETTINGS: RBW = VBW = 3MHz

Note: The maximum value of expanded measurement uncertainty for this test item is U = 3.34dB(30MHz-3GHz)/4.06dB(3GHz-18GHz)/4.56dB(18GHz-40GHz), k = 2

A.2 FIELD STRENGTH OF SPURIOUS RADIATION

Reference

FCC: CFR 2.1053, 22.917, 24.238

A.2.1 Measurement Method

The measurement procedures in TIA-603-E-2016 are used.

The spectrum was scanned from 30 MHz to the 10th harmonic of the highest frequency generated within the equipment, which is the transmitted carrier that can be as high as 1910 MHz. The resolution bandwidth is set as outlined in Part 24.238 and Part 22.917. The spectrum is scanned with the mobile station transmitting at carrier frequencies that pertain to low, mid and high channels of PCS1900 and GSM850.

The procedure of radiated spurious emissions is as follows:

1. EUT was placed on a 1.5 meter high non-conductive stand at a 3 meter test distance from the receive antenna. A receiving antenna was placed on the antenna mast 3 meters from the EUT for emission measurements. The height of receiving antenna is 1.5m. The test setup refers to figure below. Detected emissions were maximized at each frequency by rotating the EUT through 360° and adjusting the receiving antenna polarization. The radiated emission measurements of all non-harmonic and harmonics of the transmit frequency through the 10th harmonic were measured with peak detector.

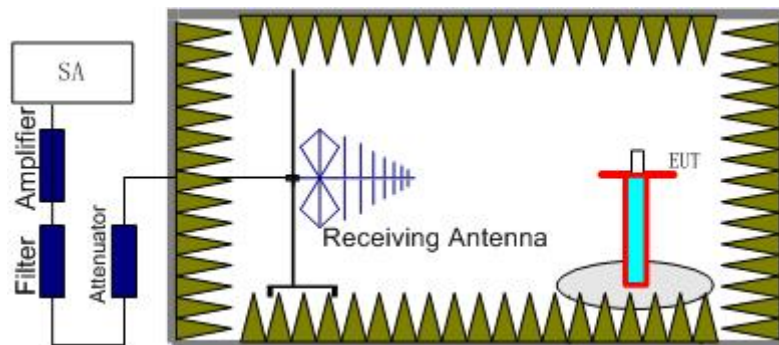

2. The EUT is then put into continuously transmitting mode at its maximum power level during the test. And the maximum value of the receiver should be recorded as (Pr). The placement of

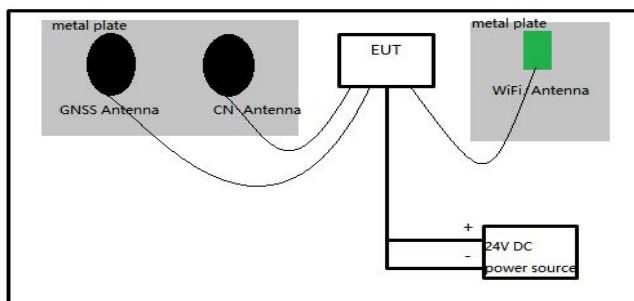

3. The EUT was tested in two states, horizontal and vertical, as shown in the attachment.

Additionally, during the testing, the WLAN which worked on 802.11b channel 6 (Power level is 14 and modulation group is 0) was continuously launched, and GNSS function was on.

4. The EUT shall be replaced by a substitution antenna. The test setup refers to figure below.

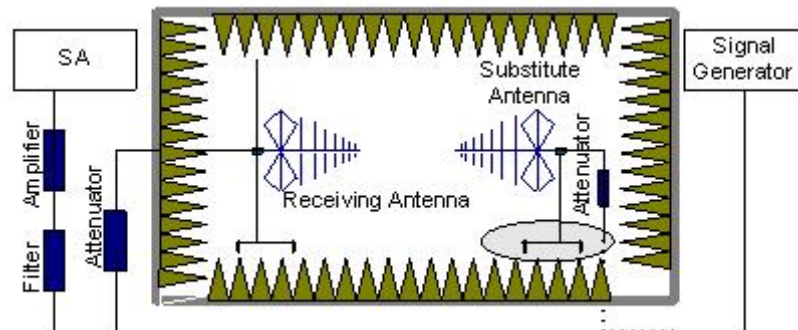

In the chamber, an substitution antenna for the frequency band of interest is placed at the reference point of the chamber. An RF Signal source for the frequency band of interest is connected to the substitution antenna with a cable that has been constructed to not interfere with the radiation pattern of the antenna. A power (P_{Mea}) is applied to the input of the substitution antenna, and adjust the level of the signal generator output until the value of the receiver reach the previously recorded (P_r). The power of signal source (P_{Mea}) is recorded. The test should be performed by rotating the test item and adjusting the receiving antenna polarization.

5. The Path loss (P_{pl}) between the Signal Source with the Substitution Antenna and the Substitution Antenna Gain(dBi) (G_a) should be recorded after test.

A amplifier should be connected in for the test.

The Path loss (P_{pl}) is the summation of the cable loss and the gain of the amplifier.

The measurement results are obtained as described below:

$$\text{Power(EIRP)} = P_{Mea} - P_{pl} + G_a$$

6. This value is EIRP since the measurement is calibrated using an antenna of known gain (2.15 dBi) and known input power.
7. ERP can be calculated from EIRP by subtracting the gain of the dipole, $ERP = EIRP - 2.15\text{dB}$.

A.2.2 Measurement Limit

Part 24.238 and Part 22.917 specify that the power of any emission outside of the authorized operating frequency ranges must be attenuated below the transmitting power (P) by a factor of at least $43 + 10 \log(P)$ dB.

The specification that emissions shall be attenuated below the transmitter power (P) by at least $43 + 10 \log(P)$ dB, translates in the relevant power range (1 to 0.001 W) to -13 dBm. At 1 W the specified minimum attenuation becomes 43 dB and relative to a 30 dBm (1 W) carrier becomes a limit of -13 dBm. At 0.001 W (0 dBm) the minimum attenuation is 13 dB, which again yields a limit of -13 dBm. In this way a translation of the specification from relative to absolute terms is carried out.

A.2.3 Measurement Results

Radiated emissions measurements were made only at the upper, middle, and lower carrier frequencies of the PCS1900 band (1850.2 MHz, 1880 MHz and 1909.8 MHz) and GSM850 band (824.2MHz, 836.6MHz, 848.8MHz) . It was decided that measurements at these three carrier frequencies would be sufficient to demonstrate compliance with emissions limits because it was seen that all the significant spurs occur well outside the band and no radiation was seen from a carrier in one block of the PCS1900 ,GSM850 into any of the other blocks. The equipment must still, however, meet emissions requirements with the carrier at all frequencies over which it is capable of operating and it is the manufacturer's responsibility to verify this.

A.2.4 Measurement Results Table

EUT- Horizontal

Frequency	Channel	Frequency Range	Result
GSM 850MHz	Low	30MHz-10GHz	Pass
	Middle	30MHz-10GHz	Pass
	High	30MHz-10GHz	Pass
GSM 1900MHz	Low	30MHz-20GHz	Pass
	Middle	30MHz-20GHz	Pass
	High	30MHz-20GHz	Pass

EUT-Vertical

Frequency	Channel	Frequency Range	Result
GSM 850MHz	Low	30MHz-10GHz	Pass
	Middle	30MHz-10GHz	Pass
	High	30MHz-10GHz	Pass
GSM 1900MHz	Low	30MHz-20GHz	Pass
	Middle	30MHz-20GHz	Pass
	High	30MHz-20GHz	Pass

A.2.5 Sweep Table

Working Frequency	Subrange (GHz)	RBW	VBW	Sweep time (s)
850MHz	0.03~1	100KHz	300KHz	10
	1-2	1 MHz	3 MHz	2
	2~5	1 MHz	3 MHz	3
	5~8	1 MHz	3 MHz	3
	8~10	1 MHz	3 MHz	3
1900MHz	0.03~1	100KHz	300KHz	10
	1-2	1 MHz	3 MHz	2
	2~5	1 MHz	3 MHz	3
	5~8	1 MHz	3 MHz	3
	8~11	1 MHz	3 MHz	3
	11~14	1 MHz	3 MHz	3
	14~18	1 MHz	3 MHz	3
18~20	1 MHz	3 MHz	2	

EUT-Horizontal

GPRS Mode Channel 128/824.2MHz with GNSS function was on and WLAN was continuously launched (WLAN was worked on 802.11b channel 6,power level is 14 and modulation group is 0)

Frequency(MHz)	P _{Mea} (dBm)	Path loss	Antenna Gain(dBi)	Peak ERP(dBm)	Limit (dBm)	Polarization
2911.50	-41.21	1.00	11.40	-32.96	-13.00	H
4874.00	-59.67	1.40	12.60	-50.62	-13.00	V
12867.50	-58.94	2.50	13.70	-49.89	-13.00	V
14385.50	-55.92	2.60	11.90	-48.77	-13.00	V
15603.00	-59.13	2.70	15.50	-48.48	-13.00	H
16888.50	-55.02	2.90	13.20	-46.87	-13.00	V

GPRS Mode Channel 190/836.6MHz with GNSS function was on and WLAN was continuously launched (WLAN was worked on 802.11b channel 6,power level is 14 and modulation group is 0)

Frequency(MHz)	P _{Mea} (dBm)	Path loss	Antenna Gain(dBi)	Peak ERP(dBm)	Limit (dBm)	Polarization
2929.30	-40.98	1.00	11.40	-32.73	-13.00	H
4183.00	-62.94	1.20	12.60	-53.69	-13.00	H
4874.00	-58.92	1.40	12.60	-49.87	-13.00	V
11493.00	-57.56	2.60	11.50	-50.81	-13.00	V
14163.00	-56.35	2.50	12.30	-48.70	-13.00	V
16997.00	-55.28	2.90	13.20	-47.13	-13.00	V

GPRS Mode Channel 251/848.8MHz with GNSS function was on and WLAN was continuously launched (WLAN was worked on 802.11b channel 6,power level is 14 and modulation group is 0)

Frequency(MHz)	P _{Mea} (dBm)	Path loss	Antenna Gain(dBi)	Peak ERP(dBm)	Limit (dBm)	Polarization
2927.50	-41.09	1.00	11.40	-32.84	-13.00	H
4874.00	-59.57	1.40	12.60	-50.52	-13.00	V
13206.00	-58.25	2.30	12.90	-49.80	-13.00	V
14458.00	-56.10	2.60	11.90	-48.95	-13.00	H
15931.00	-60.31	2.60	16.90	-48.16	-13.00	H
16911.00	-53.80	2.90	13.20	-45.65	-13.00	V

Note: The maximum value of expanded measurement uncertainty for this test item is $U = 3.34\text{dB}(30\text{MHz}-3\text{GHz})/4.06\text{dB}(3\text{GHz}-18\text{GHz})/4.56\text{dB}(18\text{GHz}-40\text{GHz})$, $k = 2$

GPRS Mode Channel 512/1850.2MHz with GNSS function was on and WLAN was continuously launched (WLAN was worked on 802.11b channel 6,power level is 14 and modulation group is 0)

Frequency(MHz)	P _{Mea} (dBm)	Path loss	Antenna Gain(dBi)	Peak EIRP(dBm)	Limit (dBm)	Polarization
2894.40	-41.32	1.00	11.40	-30.92	-13.00	H
3700.00	-62.38	1.10	12.30	-51.18	-13.00	V
4874.00	-60.29	1.40	12.60	-49.09	-13.00	H
12102.00	-58.93	2.60	13.10	-48.43	-13.00	V
14823.00	-56.93	2.70	13.00	-46.63	-13.00	V
17056.50	-55.27	2.90	13.20	-44.97	-13.00	H

GPRS Mode Channel 661/1880.0MHz with GNSS function was on and WLAN was continuously launched (WLAN was worked on 802.11b channel 6,power level is 14 and modulation group is 0)

Frequency(MHz)	P _{Mea} (dBm)	Path loss	Antenna Gain(dBi)	Peak EIRP(dBm)	Limit (dBm)	Polarization
2910.40	-40.83	1.00	11.40	-30.43	-13.00	H
3760.00	-60.08	1.10	12.60	-48.58	-13.00	V
4874.00	-60.35	1.40	12.60	-49.15	-13.00	H
13245.50	-58.77	2.30	12.90	-48.17	-13.00	V
15341.50	-56.02	2.70	13.00	-45.72	-13.00	H
16978.00	-55.35	2.90	13.20	-45.05	-13.00	H

GPRS Mode Channel 810/1909.8MHz with GNSS function was on and WLAN was continuously launched (WLAN was worked on 802.11b channel 6,power level is 14 and modulation group is 0)

Frequency(MHz)	P _{Mea} (dBm)	Path loss	Antenna Gain(dBi)	Peak EIRP(dBm)	Limit (dBm)	Polarization
2860.30	-42.57	1.00	11.40	-32.17	-13.00	V
3819.50	-63.06	1.30	12.60	-51.76	-13.00	V
4874.00	-59.51	1.40	12.60	-48.31	-13.00	V
12881.00	-59.81	2.50	13.70	-48.61	-13.00	V
15251.50	-56.72	2.70	13.00	-46.42	-13.00	H
16986.50	-55.04	2.90	13.20	-44.74	-13.00	V

Note: The maximum value of expanded measurement uncertainty for this test item is $U = 3.34\text{dB}(30\text{MHz}-3\text{GHz})/4.06\text{dB}(3\text{GHz}-18\text{GHz})/4.56\text{dB}(18\text{GHz}-40\text{GHz})$, $k = 2$

EUT-Vertical

GPRS Mode Channel 128/824.2MHz with GNSS function was on and WLAN was continuously launched (WLAN was worked on 802.11b channel 6,power level is 14 and modulation group is 0)

Frequency(MHz)	P _{Mea} (dBm)	Path loss	Antenna Gain(dBi)	Peak ERP(dBm)	Limit (dBm)	Polarization
2961.10	-41.41	1.00	11.40	-33.16	-13.00	H
4874.00	-60.81	1.40	12.60	-51.76	-13.00	V
11717.50	-59.41	2.50	13.10	-50.96	-13.00	H
13213.50	-59.35	2.30	12.90	-50.90	-13.00	V
14475.00	-56.14	2.60	11.90	-48.99	-13.00	H
17111.00	-55.34	2.90	13.20	-47.19	-13.00	V

GPRS Mode Channel 190/836.6MHz with GNSS function was on and WLAN was continuously launched (WLAN was worked on 802.11b channel 6,power level is 14 and modulation group is 0)

Frequency(MHz)	P _{Mea} (dBm)	Path loss	Antenna Gain(dBi)	Peak ERP(dBm)	Limit (dBm)	Polarization
2947.70	-41.15	1.00	11.40	-32.90	-13.00	H
4874.00	-59.80	1.40	12.60	-50.75	-13.00	V
12605.00	-60.00	2.60	14.10	-50.65	-13.00	V
14484.00	-56.87	2.60	11.90	-49.72	-13.00	V
15422.50	-59.79	2.40	15.50	-48.84	-13.00	V
17004.50	-54.53	2.90	13.20	-46.38	-13.00	V

GPRS Mode Channel 251/848.8MHz with GNSS function was on and WLAN was continuously launched (WLAN was worked on 802.11b channel 6,power level is 14 and modulation group is 0)

Frequency(MHz)	P _{Mea} (dBm)	Path loss	Antenna Gain(dBi)	Peak ERP(dBm)	Limit (dBm)	Polarization
2906.70	-41.78	1.00	11.40	-33.53	-13.00	H
4874.00	-61.16	1.40	12.60	-52.11	-13.00	V
10603.50	-59.05	2.40	11.00	-52.60	-13.00	V
12720.50	-59.14	2.70	13.70	-50.29	-13.00	H
14832.00	-57.07	2.70	13.00	-48.92	-13.00	V
16770.00	-57.40	2.90	15.20	-47.25	-13.00	H

Note: The maximum value of expanded measurement uncertainty for this test item is $U = 3.34\text{dB}(30\text{MHz}-3\text{GHz})/4.06\text{dB}(3\text{GHz}-18\text{GHz})/4.56\text{dB}(18\text{GHz}-40\text{GHz})$, $k = 2$

GPRS Mode Channel 512/1850.2MHz with GNSS function was on and WLAN was continuously launched (WLAN was worked on 802.11b channel 6,power level is 14 and modulation group is 0)

Frequency(MHz)	P _{Mea} (dBm)	Path loss	Antenna Gain(dBi)	Peak EIRP(dBm)	Limit (dBm)	Polarization
2881.10	-42.31	1.00	11.40	-31.91	-13.00	V
3700.50	-62.39	1.10	12.30	-51.19	-13.00	H
4874.00	-60.91	1.40	12.60	-49.71	-13.00	V
12809.00	-59.43	2.70	13.70	-48.43	-13.00	V
14422.00	-56.43	2.60	11.90	-47.13	-13.00	V
17122.00	-55.34	2.90	13.20	-45.04	-13.00	H

GPRS Mode Channel 661/1880.0MHz with GNSS function was on and WLAN was continuously launched (WLAN was worked on 802.11b channel 6,power level is 14 and modulation group is 0)

Frequency(MHz)	P _{Mea} (dBm)	Path loss	Antenna Gain(dBi)	Peak EIRP(dBm)	Limit (dBm)	Polarization
2937.90	-40.86	1.00	11.40	-30.46	-13.00	H
3760.00	-62.68	1.10	12.60	-51.18	-13.00	H
4874.00	-59.36	1.40	12.60	-48.16	-13.00	V
13362.00	-58.52	2.50	12.90	-48.12	-13.00	H
15432.50	-59.21	2.40	15.50	-46.11	-13.00	H
16379.00	-57.44	2.70	15.20	-44.94	-13.00	H

GPRS Mode Channel 810/1909.8MHz with GNSS function was on and WLAN was continuously launched (WLAN was worked on 802.11b channel 6,power level is 14 and modulation group is 0)

Frequency(MHz)	P _{Mea} (dBm)	Path loss	Antenna Gain(dBi)	Peak EIRP(dBm)	Limit (dBm)	Polarization
2941.10	-41.81	1.00	11.40	-31.41	-13.00	H
3819.50	-64.32	1.30	12.60	-53.02	-13.00	H
4874.50	-60.43	1.40	12.60	-49.23	-13.00	V
12110.00	-58.53	2.60	13.10	-48.03	-13.00	H
15972.50	-59.63	2.60	16.90	-45.33	-13.00	V
17073.50	-55.75	2.90	13.20	-45.45	-13.00	V

Note: The maximum value of expanded measurement uncertainty for this test item is $U = 3.34\text{dB}(30\text{MHz}-3\text{GHz})/4.06\text{dB}(3\text{GHz}-18\text{GHz})/4.56\text{dB}(18\text{GHz}-40\text{GHz})$, $k = 2$

A.3 FREQUENCY STABILITY

Reference

FCC: CFR Part 2.1055, 22.355, 24.235

A.3.1 Method of Measurement

In order to measure the carrier frequency under the condition of AFC lock, it is necessary to make measurements with the EUT in a "call mode". This is accomplished with the use of R&S CMU200 DIGITAL RADIO COMMUNICATION TESTER.

1. Measure the carrier frequency at room temperature.
2. Subject the EUT to overnight soak at -30°C.
3. With the EUT, powered via nominal voltage, connected to the CMU200 and in a simulated call on mid channel of PCS 1900 and GSM850, measure the carrier frequency. These measurements should be made within 2 minutes of Powering up the EUT, to prevent significant self-warming.
4. Repeat the above measurements at 10°C increments from -30°C to +50°C. Allow at least 1 1/2 hours at each temperature, unpowered, before making measurements.
5. Remeasure carrier frequency at room temperature with nominal voltage. Vary supply voltage from minimum voltage to maximum voltage, in 0.1Volt increments remeasuring carrier frequency at each voltage. Pause at nominal voltage for 1 1/2 hours unpowered, to allow any self-heating to stabilize, before continuing.
6. Subject the EUT to overnight soak at +50°C.
7. With the EUT, powered via nominal voltage, connected to the CMU200 and in a simulated call on the centre channel, measure the carrier frequency. These measurements should be made within 2 minutes of Powering up the EUT, to prevent significant self-warming.
8. Repeat the above measurements at 10°C increments from +50°C to -30°C. Allow at least 1 1/2 hours at each temperature, unpowered, before making measurements.
9. At all temperature levels hold the temperature to +/- 0.5°C during the measurement procedure.

A.3.2 Measurement Limit

A.3.2.1 For Hand carried battery powered equipment

According to the JTC standard the frequency stability of the carrier shall be accurate to within 0.1 ppm of the received frequency from the base station. This accuracy is sufficient to meet Sec. 24.235, Frequency Stability. The frequency stability shall be sufficient to ensure that the fundamental emission stays within the authorized frequency block. As this transceiver is considered "Hand carried, battery powered equipment" Section 2.1055(d)(2) applies. This requires that the lower voltage for frequency stability testing be specified by the manufacturer. This transceiver is specified to operate with an input voltage of between 19.2VDC and 28.8VDC, with a nominal voltage of 24VDC. Operation above or below these voltage limits is prohibited by transceiver software in order to prevent improper operation as well as to protect components from overstress. These voltages represent a tolerance of -10 % and +12.5 %. For the purposes of measuring frequency stability these voltage limits are to be used.

A.3.2.2 For equipment powered by primary supply voltage

According to the JTC standard the frequency stability of the carrier shall be accurate to within 0.1 ppm of the received frequency from the base station. This accuracy is sufficient to meet Sec.

24.235, Frequency Stability. The frequency stability shall be sufficient to ensure that the fundamental emission stays within the authorized frequency block. For this EUT section 2.1055(d)(1) applies. This requires varying primary supply voltage from 85 to 115 percent of the nominal value for other than hand carried battery equipment.

A.3.3 Measurement results

GPRS 850

Frequency Error vs Voltage

Voltage(V)	Frequency error(Hz)	Frequency error(ppm)
19.2	-15	0.018
24	8	0.010
28.8	16	0.019

Frequency Error vs Temperature

temperature(°C)	Frequency error(Hz)	Frequency error(ppm)
-30	23	0.027
-20	-9	0.011
-10	18	0.022
0	7	0.008
10	14	0.017
20	22	0.026
30	13	0.016
40	5	0.006
50	11	0.013

EGPRS 850 - 8PSK

Frequency Error vs Voltage

Voltage(V)	Frequency error(Hz)	Frequency error(ppm)
19.2	-40	0.048
24	-50	0.060
28.8	-43	0.052

Frequency Error vs Temperature

temperature(°C)	Frequency error(Hz)	Frequency error(ppm)
-30	-41	0.050
-20	-44	0.053
-10	-43	0.052
0	-42	0.050
10	-45	0.053
20	-45	0.054
30	-39	0.047
40	-39	0.047
50	-45	0.054

Expanded measurement uncertainty is 10Hz, $k = 2$

GPRS 1900

Frequency Error vs Voltage

Voltage(V)	Frequency error(Hz)	Frequency error(ppm)
19.2	25	0.013
24	-16	0.009
28.8	-3	0.002

Frequency Error vs Temperature

temperature(°C)	Frequency error(Hz)	Frequency error(ppm)
-30	-8	0.004
-20	11	0.006
-10	14	0.007
0	22	0.012
10	-9	0.005
20	-7	0.004
30	3	0.002
40	15	0.008
50	26	0.014

EGPRS 1900 - 8PSK

Frequency Error vs Voltage

Voltage(V)	Frequency error(Hz)	Frequency error(ppm)
19.2	-41	0.022
24	-48	0.025
28.8	-40	0.021

Frequency Error vs Temperature

temperature(°C)	Frequency error(Hz)	Frequency error(ppm)
-30	-44	0.023
-20	-43	0.023
-10	-43	0.023
0	-42	0.022
10	-39	0.021
20	-45	0.024
30	-40	0.021
40	-40	0.021
50	-43	0.023

Expanded measurement uncertainty is 10Hz, $k = 2$

A.4 OCCUPIED BANDWIDTH

Reference

FCC: CFR Part 2.1049, 22.917, 24.238

A.4.1 Occupied Bandwidth Results

Occupied bandwidth measurements are only provided for selected frequencies in order to reduce the amount of submitted data. Data were taken at the extreme and mid frequencies of the US Cellular/PCS frequency bands. The table below lists the measured 99% BW. Spectrum analyzer plots are included on the following pages.

- a) The spectrum analyzer center frequency is set to the nominal EUT channel center frequency. The frequency span for the spectrum analyzer shall be set wide enough to capture all modulation products including the emission skirts (i.e., two to five times the OBW).
- b) The nominal IF filter bandwidth (3 dB RBW) shall be in the range of 1 to 5 % of the anticipated OBW, and the VBW shall be at least 3 times the RBW.
- c) Set the reference level of the instrument as required to keep the signal from exceeding the maximum input mixer level for linear operation. In general, the peak of the spectral envelope must be at least $10\log(OBW / RBW)$ below the reference level.
- d) Set the detection mode to peak, and the trace mode to max hold.
- e) Use the 99 % power bandwidth function of the spectrum analyzer and report the measured bandwidth.

GPRS 850(99% BW)

Frequency(MHz)	Occupied Bandwidth (99% BW)(kHz)
824.2	243.59
836.6	242.79
848.8	245.19

GPRS 850

Channel 128-Occupied Bandwidth (99% BW)

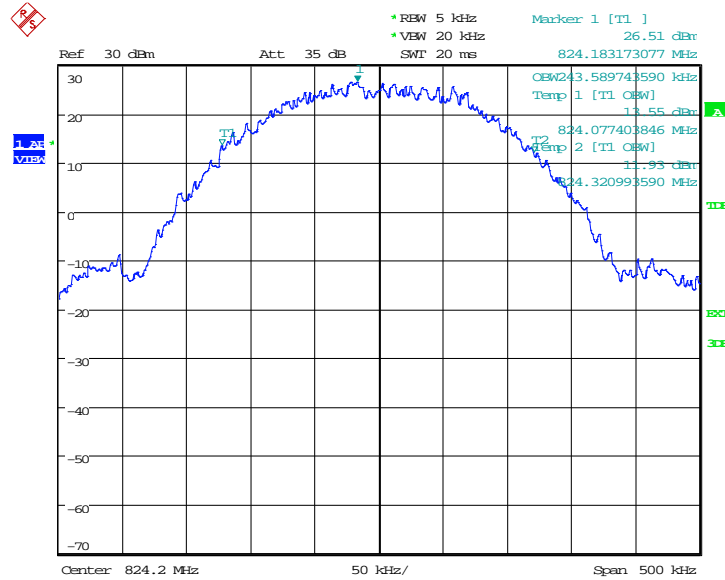

Date: 6.MAR.2019 05:36:48

Channel 190-Occupied Bandwidth (99% BW)

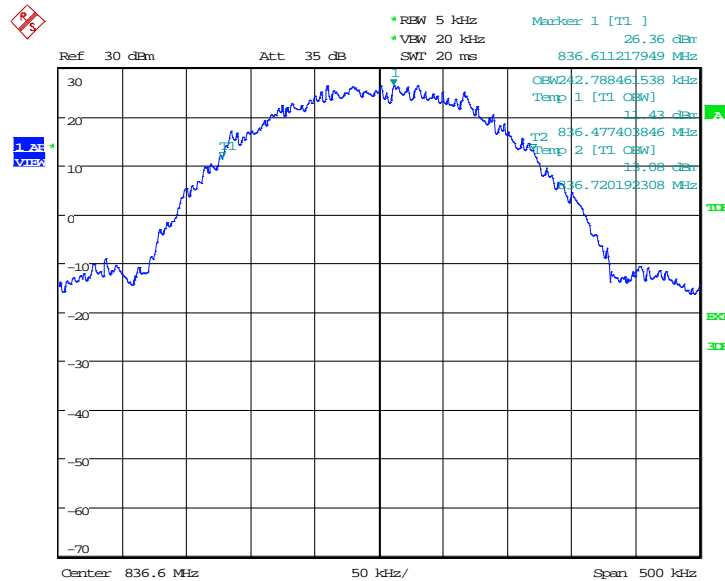

Date: 6.MAR.2019 05:37:20

Channel 251-Occupied Bandwidth (99% BW)

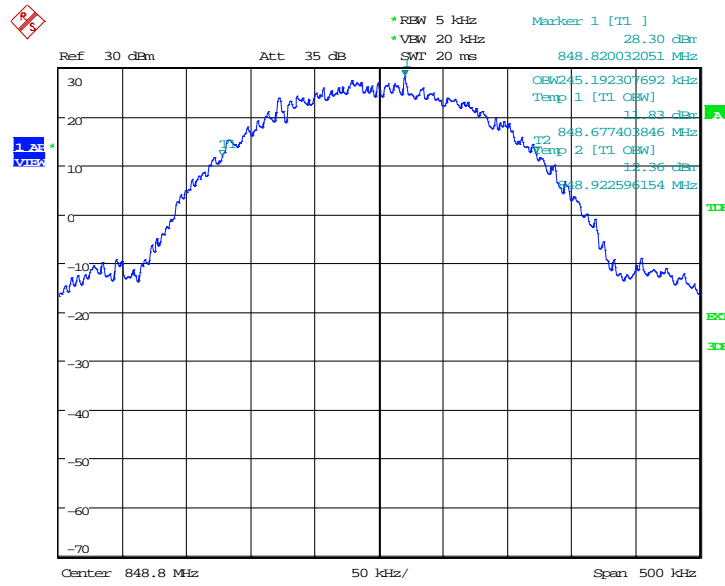

Date: 6.MAR.2019 05:37:51

EGPRS 850-8PSK(99% BW)

Frequency(MHz)	Occupied Bandwidth (99% BW)(kHz)
824.2	250.00
836.6	243.59
848.8	244.39

EGPRS 850-8PSK

Channel 128-Occupied Bandwidth (99% BW)

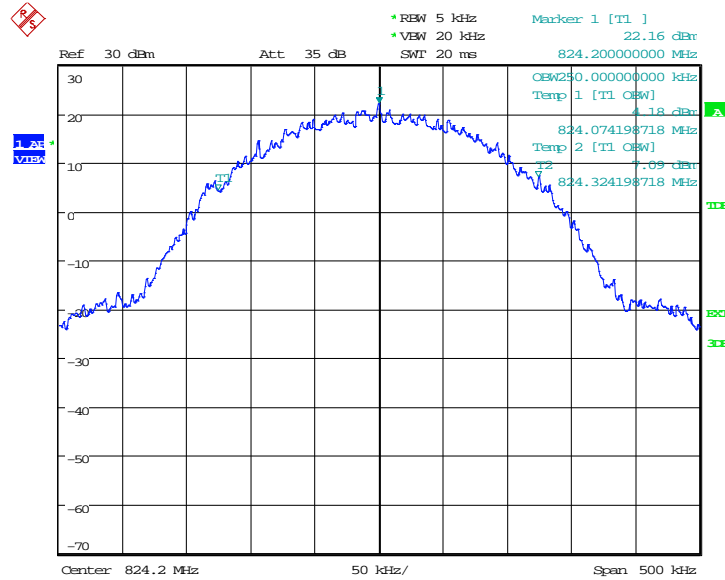

Date: 6.MAR.2019 06:13:38

Channel 190-Occupied Bandwidth (99% BW)

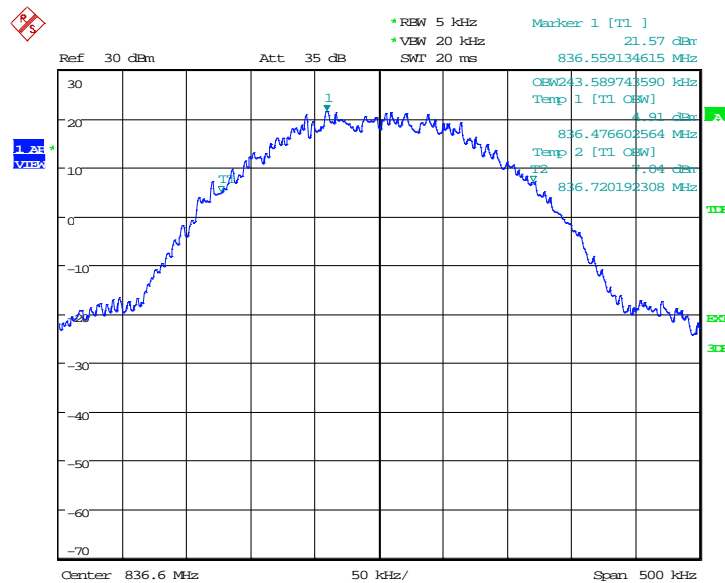

Date: 6.MAR.2019 06:14:10

Channel 251-Occupied Bandwidth (99% BW)

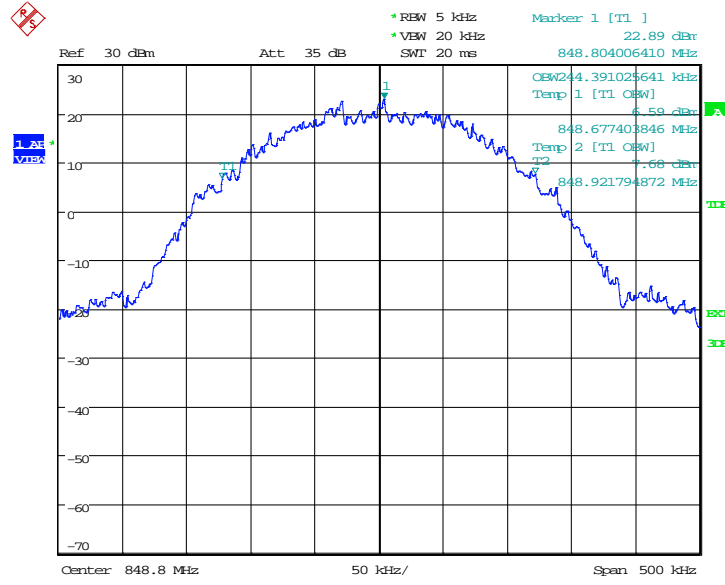

Date: 6.MAR.2019 06:14:41

GPRS 1900(99% BW)

Frequency(MHz)	Occupied Bandwidth (99% BW)(kHz)
1850.2	243.59
1880.0	242.79
1909.8	243.59

GPRS 1900

Channel 512-Occupied Bandwidth (99% BW)

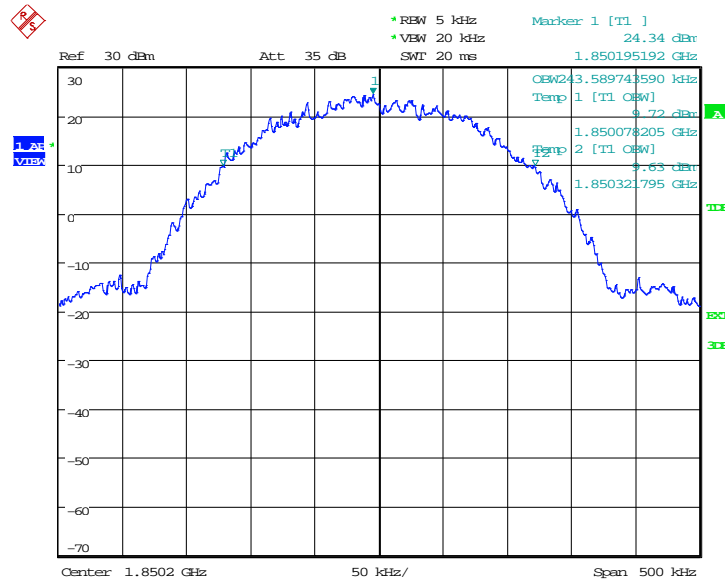

Date: 6.MAR.2019 05:54:24

Channel 661-Occupied Bandwidth (99% BW)

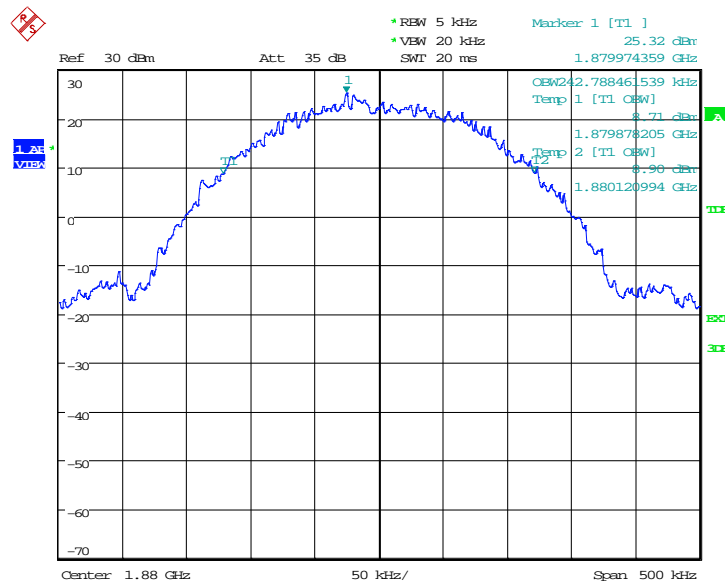

Date: 6.MAR.2019 05:54:56

Channel 810-Occupied Bandwidth (99% BW)

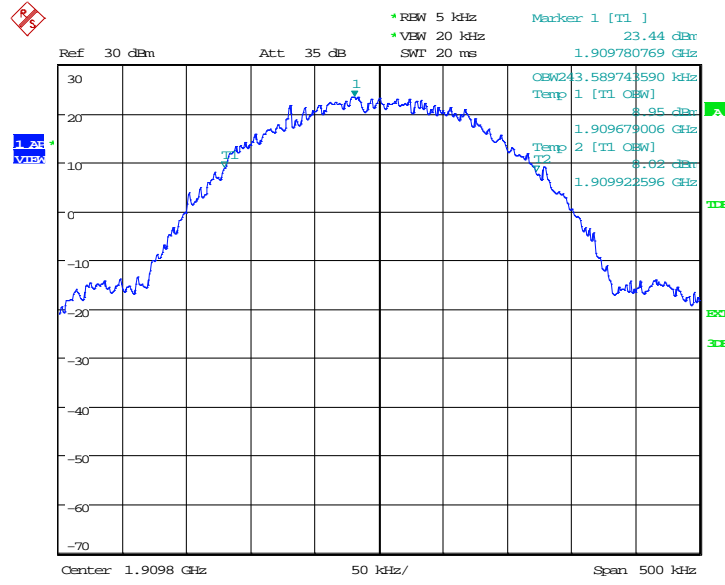

Date: 6.MAR.2019 05:55:28

EGPRS 1900-8PSK(99% BW)

Frequency(MHz)	Occupied Bandwidth (99% BW)(kHz)
1850.2	249.20
1880.0	243.59
1909.8	245.19

EGPRS 1900-8PSK

Channel 512-Occupied Bandwidth (99% BW)

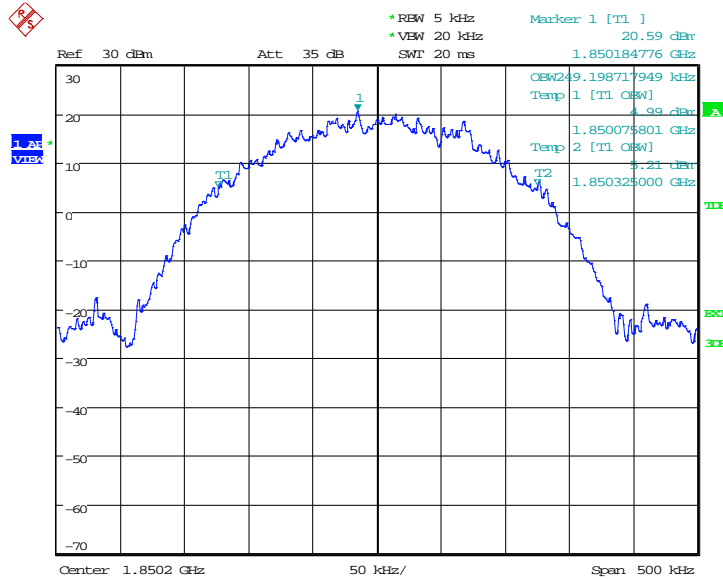

Date: 6.MAR.2019 06:24:17

Channel 661-Occupied Bandwidth (99% BW)

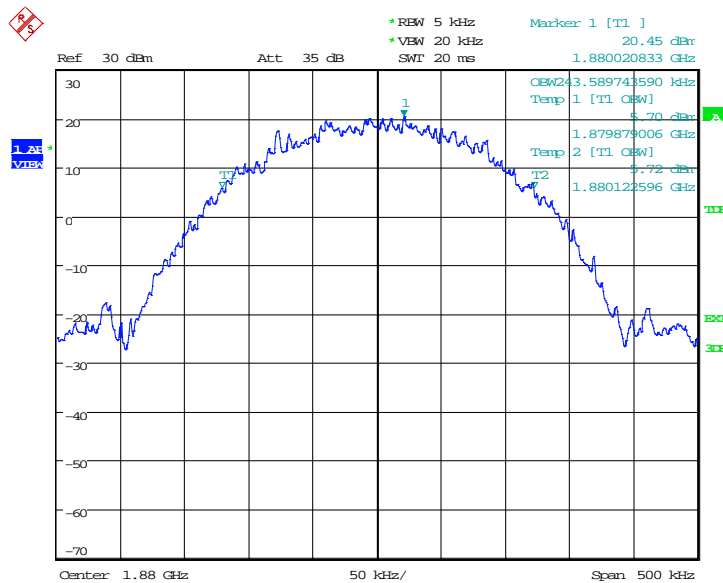

Date: 6.MAR.2019 06:24:48

Channel 810-Occupied Bandwidth (99% BW)

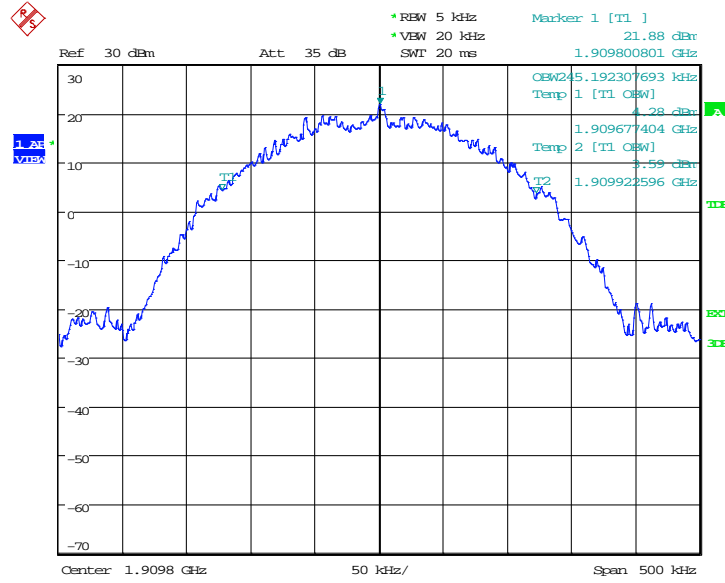

Date: 6.MAR.2019 06:25:20

Note: Expanded measurement uncertainty is $U = 3428\text{Hz}$, $k = 2$

A.5 EMISSION BANDWIDTH

Reference

FCC: CFR Part 2.1049, 22.917, 24.238

A.5.1 Emission Bandwidth Results

The emission bandwidth is defined as the width of the signal between two points, one below the carrier center frequency and one above the carrier center frequency, outside of which all emissions are attenuated at least 26 dB below the transmitter power.

Similar to conducted emissions; Emission bandwidth measurements are only provided for selected frequencies in order to reduce the amount of submitted data. Data were taken at the extreme and mid frequencies of PCS1900 band and GSM850 band. Table below lists the measured -26dB BW. Spectrum analyzer plots are included on the following pages.

GPRS 850(-26dB BW)

Frequency(MHz)	Emission Bandwidth (-26dB BW)(kHz)
824.2	312.50
836.6	316.51
848.8	314.90

GPRS 850

Channel 128-Emission Bandwidth (-26dB BW)

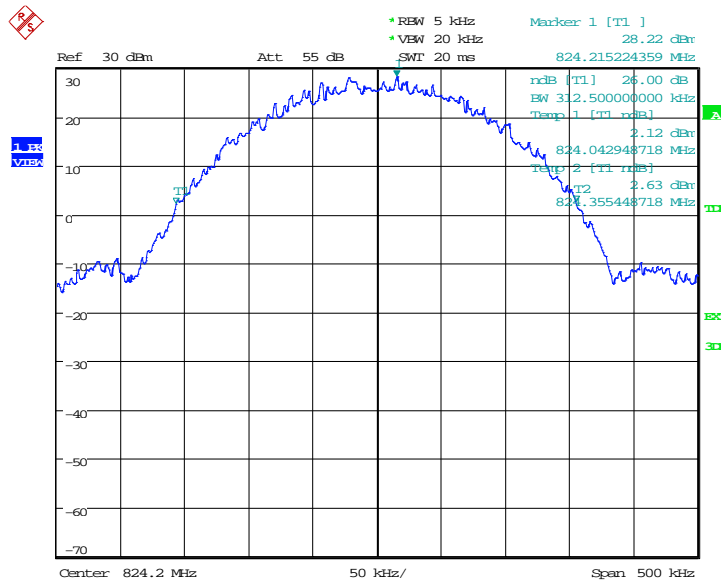

Date: 6.MAR.2019 05:38:59

Channel 190-Emission Bandwidth (-26dB BW)

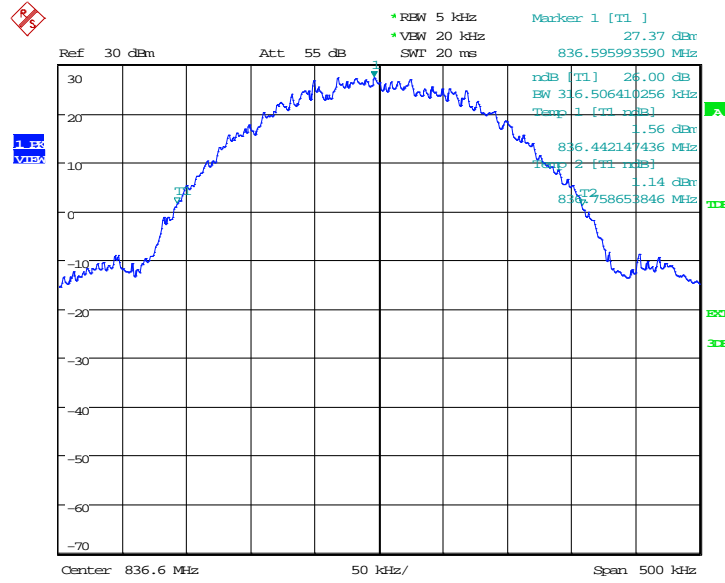

Date: 6.MAR.2019 05:40:06

Channel 251-Emission Bandwidth (-26dB BW)

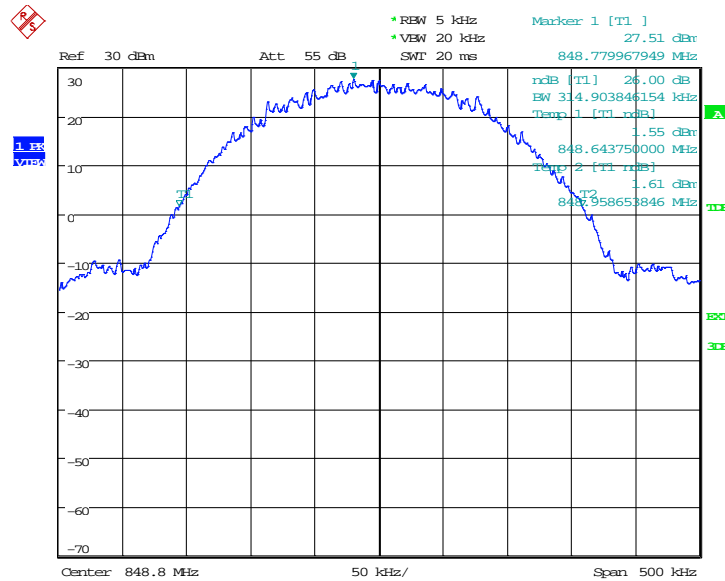

Date: 6.MAR.2019 05:41:13

EGPRS 850-8PSK(-26dB BW)

Frequency(MHz)	Emission Bandwidth (-26dB BW)(kHz)
824.2	316.51
836.6	315.71
848.8	313.30

EGPRS 850-8PSK

Channel 128-Emission Bandwidth (-26dB BW)

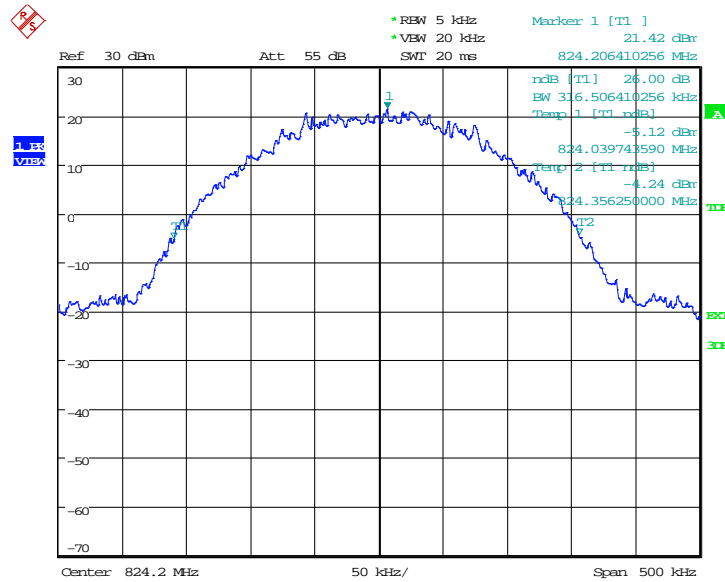

Date: 6.MAR.2019 06:15:49

Channel 190-Emission Bandwidth (-26dB BW)

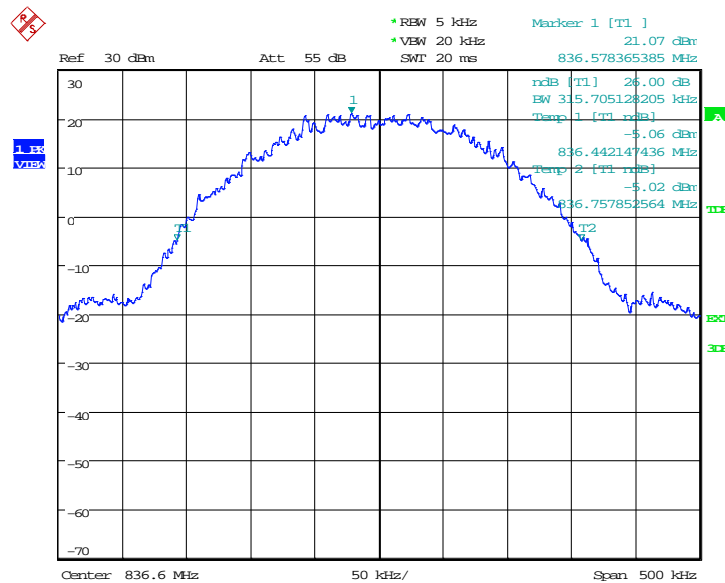

Date: 6.MAR.2019 06:16:56

Channel 251-Emission Bandwidth (-26dB BW)

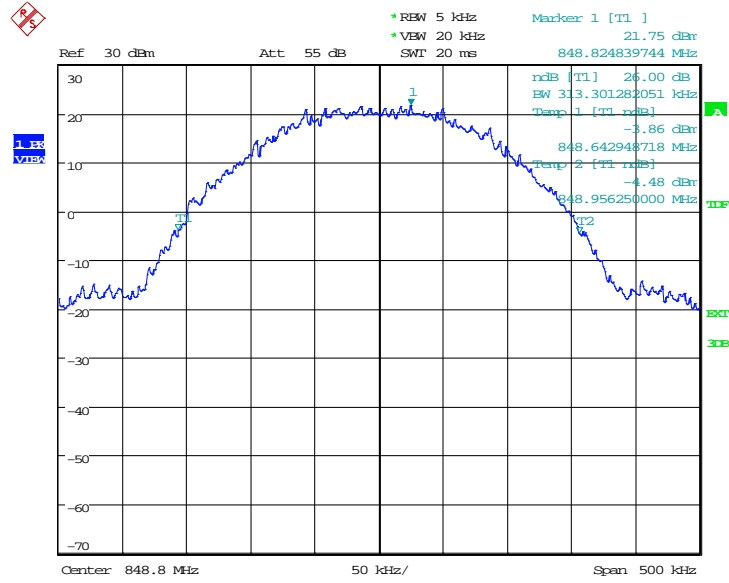

Date: 6.MAR.2019 06:18:03

GPRS 1900(-26dB BW)

Frequency(MHz)	Emission Bandwidth (-26dB BW)(kHz)
1850.2	318.11
1880.0	317.31
1909.8	313.30

GPRS 1900

Channel 512-Emission Bandwidth (-26dB BW)

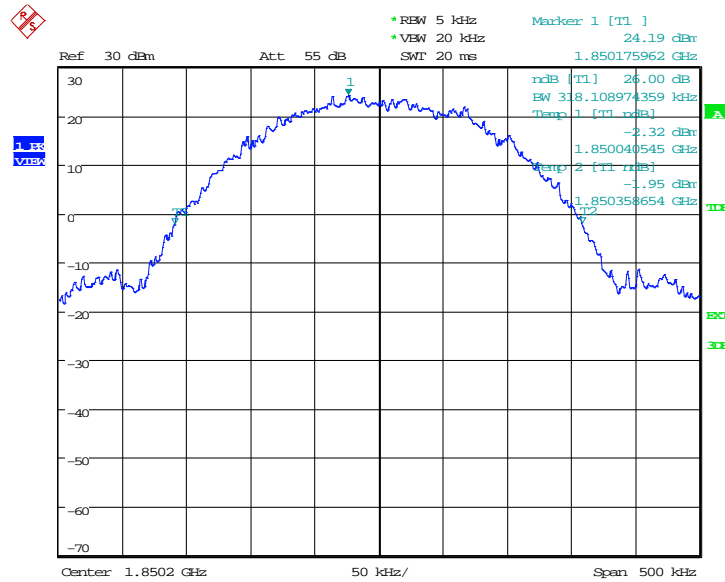

Date: 6.MAR.2019 05:56:35

Channel 661-Emission Bandwidth (-26dB BW)

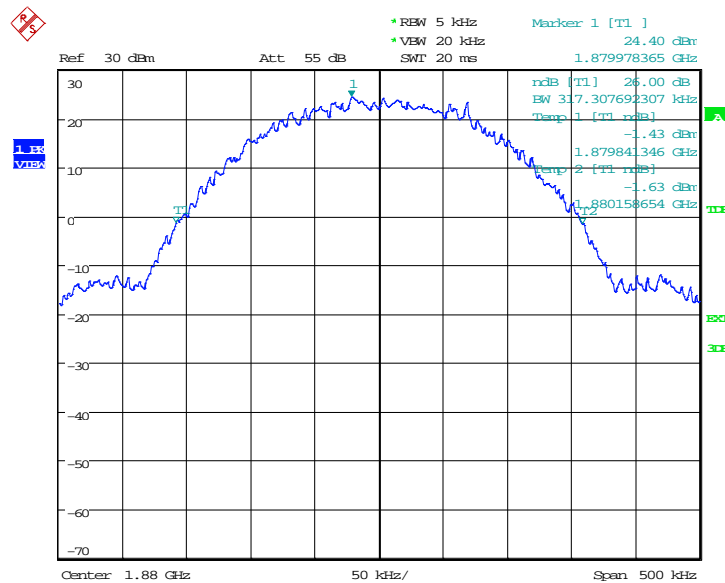

Date: 6.MAR.2019 05:57:42

Channel 810-Emission Bandwidth (-26dB BW)

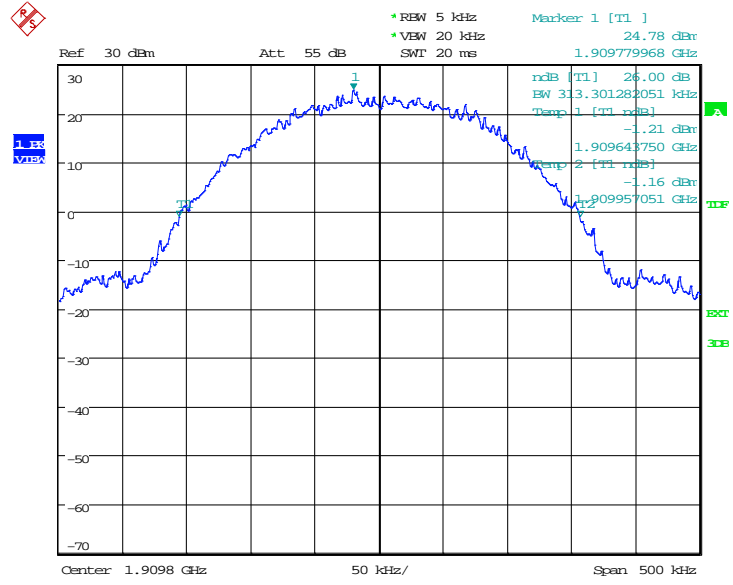

Date: 6.MAR.2019 05:58:49

EGPRS 1900-8PSK(-26dB BW)

Frequency(MHz)	Emission Bandwidth (-26dB BW)(kHz)
1850.2	311.70
1880.0	312.50
1909.8	314.10

EGPRS 1900-8PSK

Channel 512-Emission Bandwidth (-26dB BW)

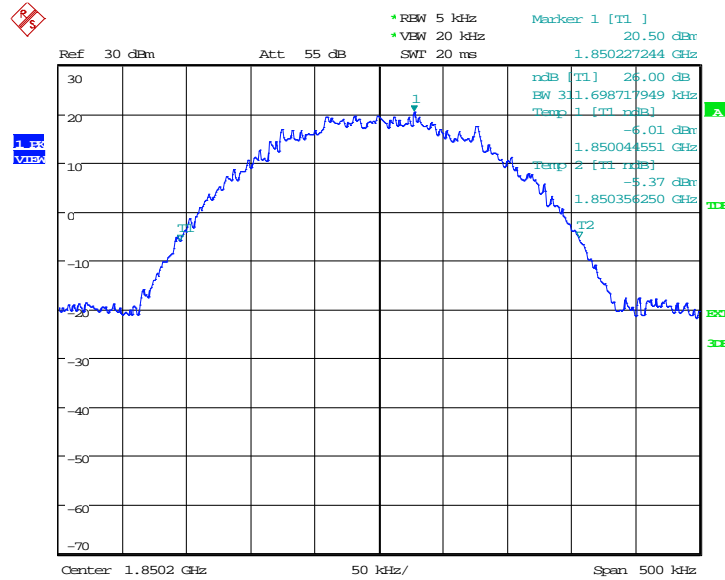

Date: 6.MAR.2019 06:26:28

Channel 661-Emission Bandwidth (-26dB BW)

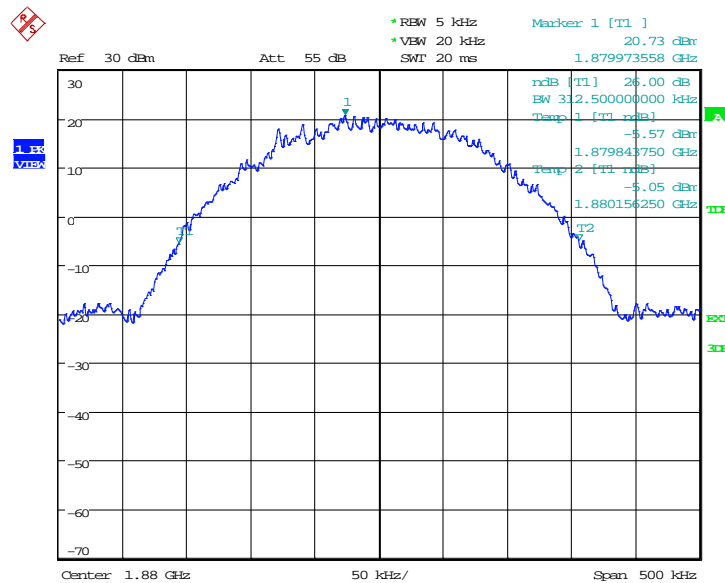

Date: 6.MAR.2019 06:27:34

Channel 810-Emission Bandwidth (-26dB BW)

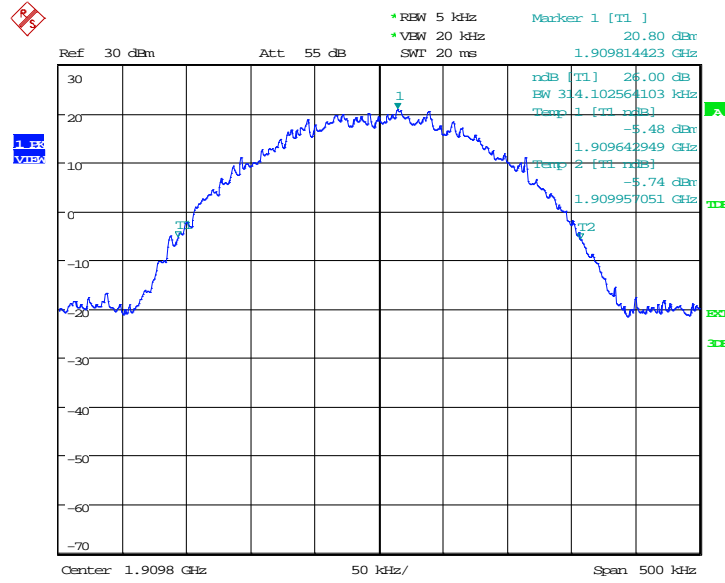

Date: 6.MAR.2019 06:28:41

Note: Expanded measurement uncertainty is $U = 3428\text{Hz}$, $k = 2$

A.6 BAND EDGE COMPLIANCE

Reference

FCC: CFR Part 2.1051, 22.917, 24.238

Measurement limit

On any frequency outside frequency band of the US Cellular/PCS spectrum, the power of any emission shall be attenuated below the transmitter power (P, in Watts) by at least $43+10\text{Log}(P)$ dB. For all power levels +30 dBm to 0 dBm, this becomes a constant specification limit of -13 dBm. A relaxation of the reference bandwidth is often provided for measurements within a specified frequency range at the edge of the authorized frequency block/band. This is often implemented by permitting the use of a narrower RBW (typically limited to a minimum RBW of 1% of the OBW) for measuring the out-of-band emissions without a requirement to integrate the result over the full reference bandwidth.

GPRS 850

LOW BAND EDGE BLOCK-A (GSM850)-Channel 128

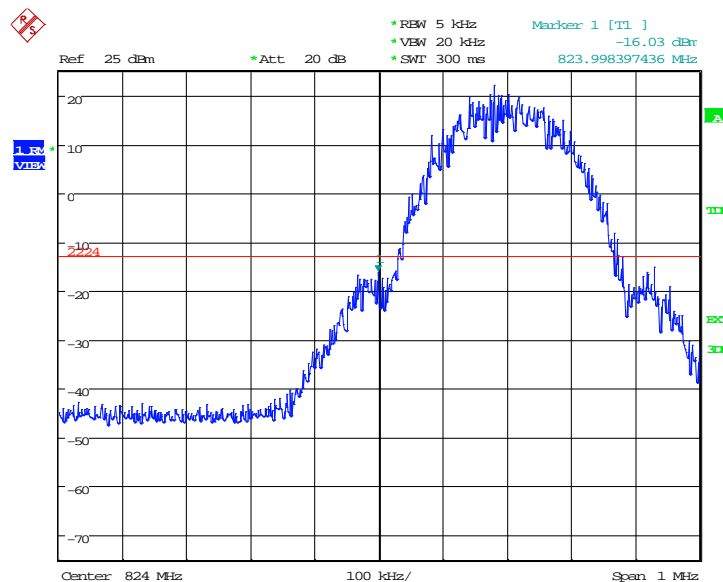

Date: 6.MAR.2019 05:41:21

HIGH BAND EDGE BLOCK-C (GSM850) –Channel 251

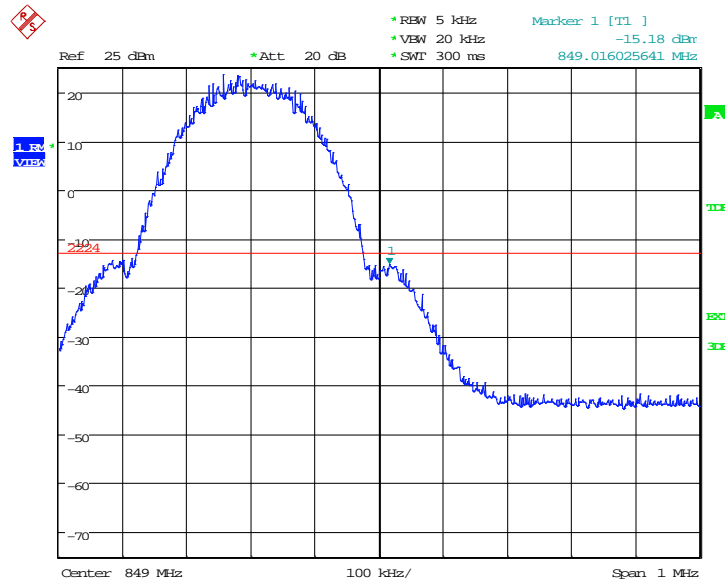

Date: 6.MAR.2019 05:43:24

**EGPRS 850-8PSK
LOW BAND EDGE BLOCK-A (GSM850)-Channel 128**

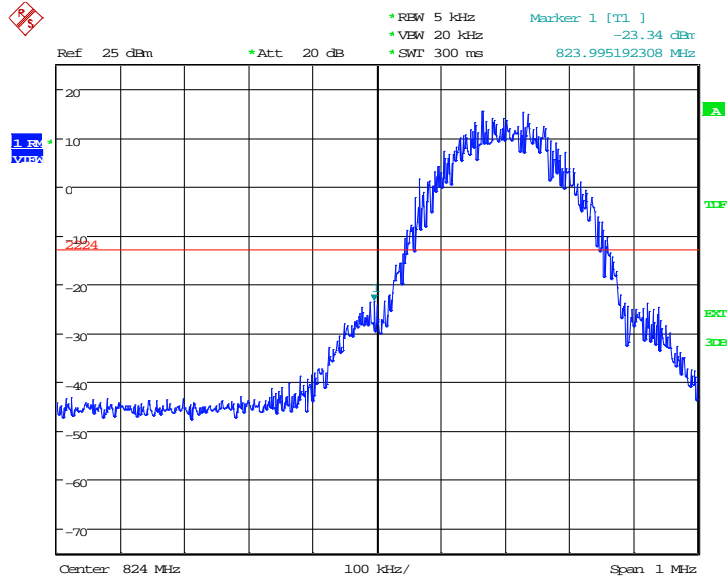

Date: 6.MAR.2019 06:18:11

HIGH BAND EDGE BLOCK-C (GSM850) –Channel 251

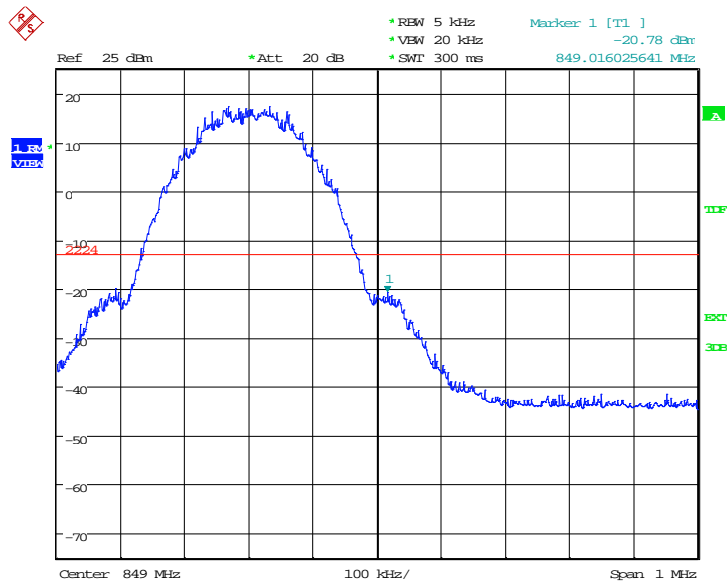

Date: 6.MAR.2019 06:20:14

GPRS 1900
LOW BAND EDGE BLOCK-A (PCS-1900)-Channel 512

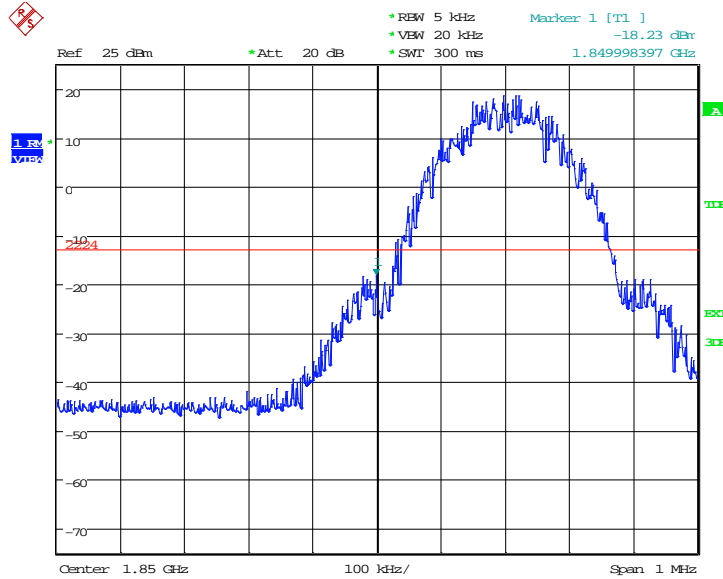

Date: 6.MAR.2019 05:58:57

HIGH BAND EDGE BLOCK-C (PCS-1900) –Channel 810

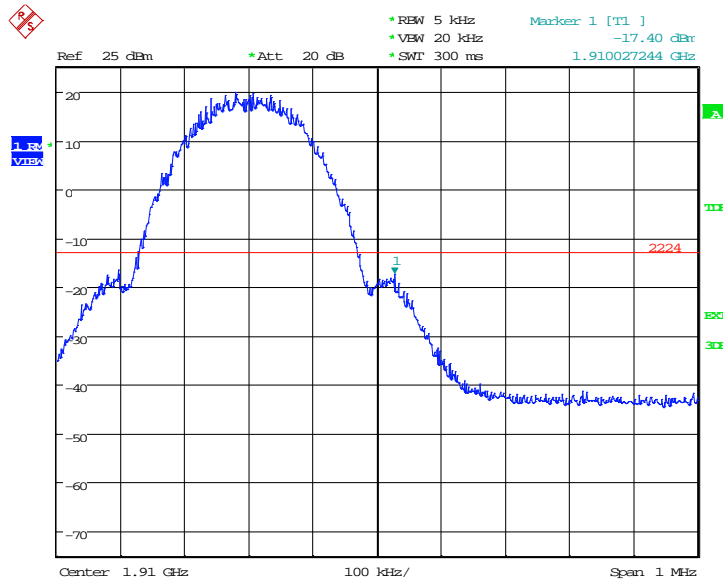

Date: 6.MAR.2019 06:01:00

**EGPRS 1900-8PSK
LOW BAND EDGE BLOCK-A (PCS-1900)-Channel 512**

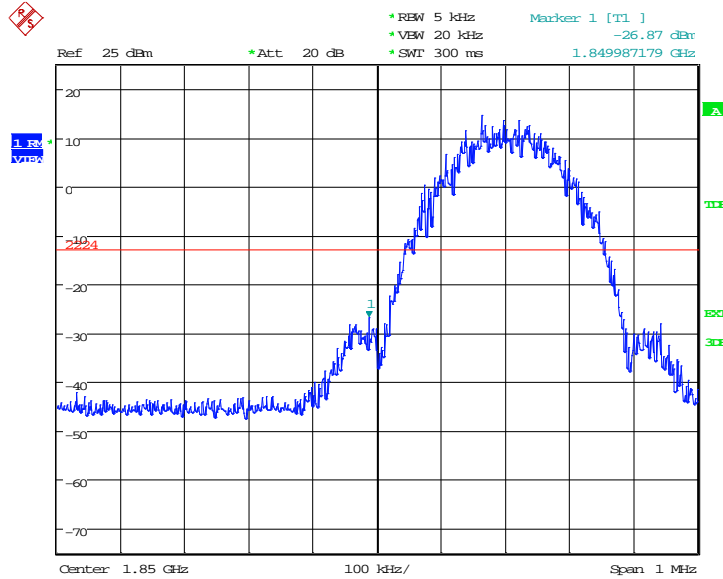

Date: 6.MAR.2019 06:28:49

HIGH BAND EDGE BLOCK-C (PCS-1900) –Channel 810

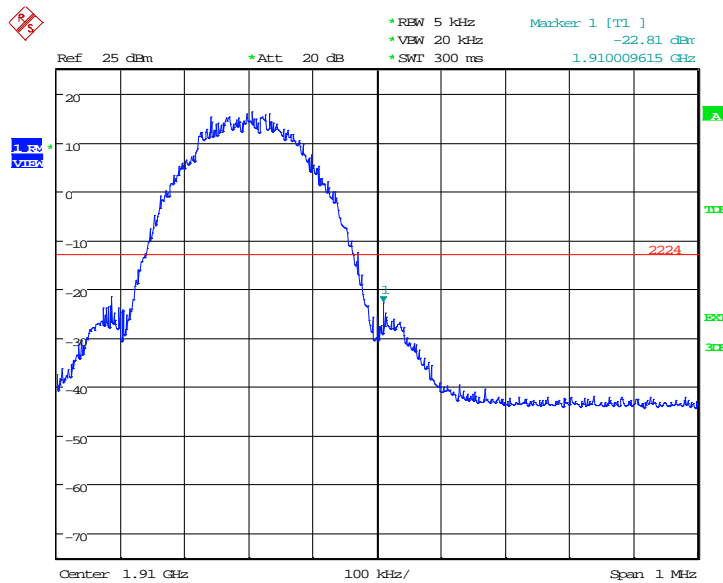

Date: 6.MAR.2019 06:30:52

Note: Expanded measurement uncertainty is $U = 0.488\text{dB}(100\text{KHz}-2\text{GHz})/1.211\text{dB}(2\text{GHz}-26.5\text{GHz})$, $k = 1.96$

A.7 CONDUCTED SPURIOUS EMISSION

Reference

FCC: CFR Part 2.1051, 22.917, 24.238

A.7.1 Measurement Method

The following steps outline the procedure used to measure the conducted emissions from the EUT.

1. Determine frequency range for measurements: From CFR 2.1051 the spectrum should be investigated from the lowest radio frequency generated in the equipment up to at least the 10th harmonic of the carrier frequency. For the mobile station equipment tested, this equates to a frequency range of 13 MHz to 9 GHz, data taken from 10 MHz to 25 GHz.
2. Determine EUT transmit frequencies: below outlines the band edge frequencies pertinent to conducted emissions testing.

GSM850 Transmitter

Channel	Frequency (MHz)
128	824.2
190	836.6
251	848.8

PCS1900 Transmitter

Channel	Frequency (MHz)
512	1850.2
661	1880.0
810	1909.8

A. 7.2 Measurement Limit

Part 24.238 and Part 22.917 specify that the power of any emission outside of the authorized operating frequency ranges must be attenuated below the transmitting power (P) by a factor of at least $43 + 10 \log(P)$ dB.

The specification that emissions shall be attenuated below the transmitter power (P) by at least $43 + 10 \log(P)$ dB, translates in the relevant power range (1 to 0.001 W) to -13 dBm. At 1 W the specified minimum attenuation becomes 43 dB and relative to a 30 dBm (1 W) carrier becomes a limit of -13 dBm. At 0.001 W (0 dBm) the minimum attenuation is 13 dB, which again yields a limit of -13 dBm. In this way a translation of the specification from relative to absolute terms is carried out.

A.7.3 Measurement result

GPRS850

Channel 128: 30MHz – 1GHz

Spurious emission limit –13dBm.

NOTE: peak above the limit line is the carrier frequency.

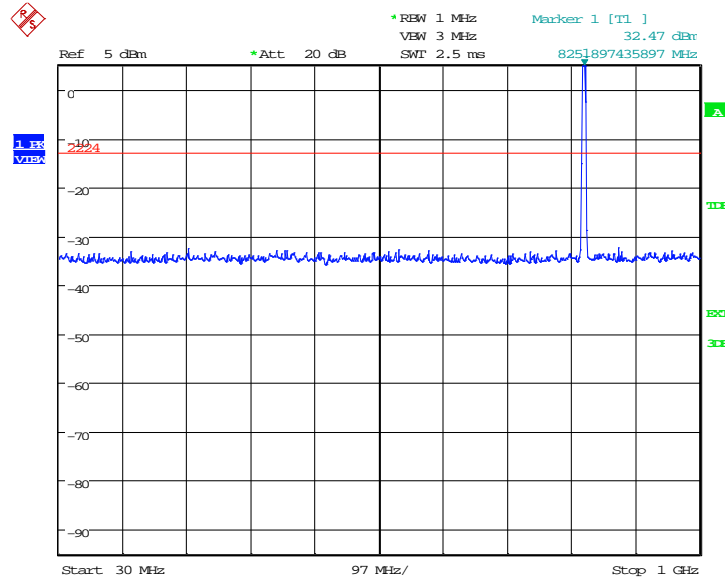

Date: 6.MAR.2019 05:43:51

Channel 128: 1GHz – 2.5GHz

Spurious emission limit –13dBm.

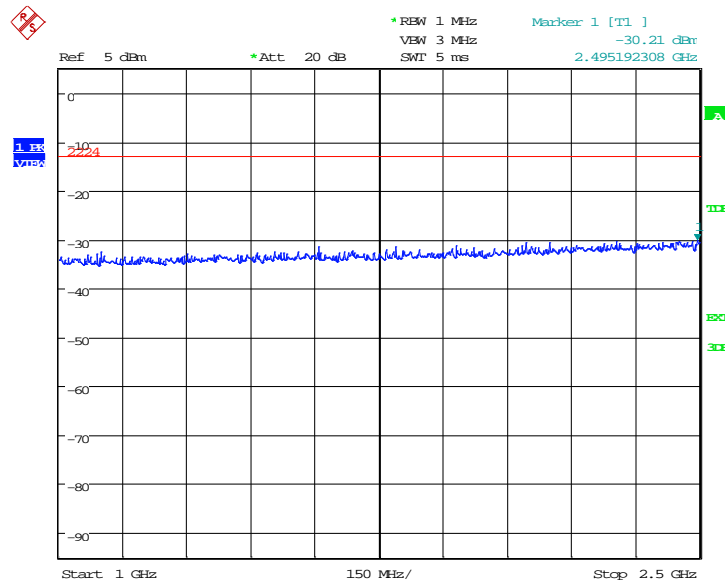

Date: 6.MAR.2019 05:44:18

Channel 128: 2.5GHz – 7.5GHz
Spurious emission limit –13dBm.

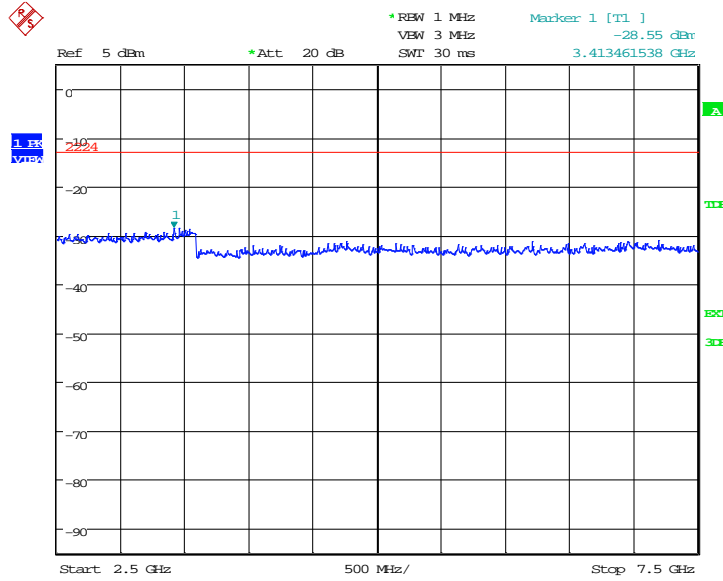

Date: 6.MAR.2019 05:44:45

Channel 128: 7.5GHz –10GHz
Spurious emission limit –13dBm.

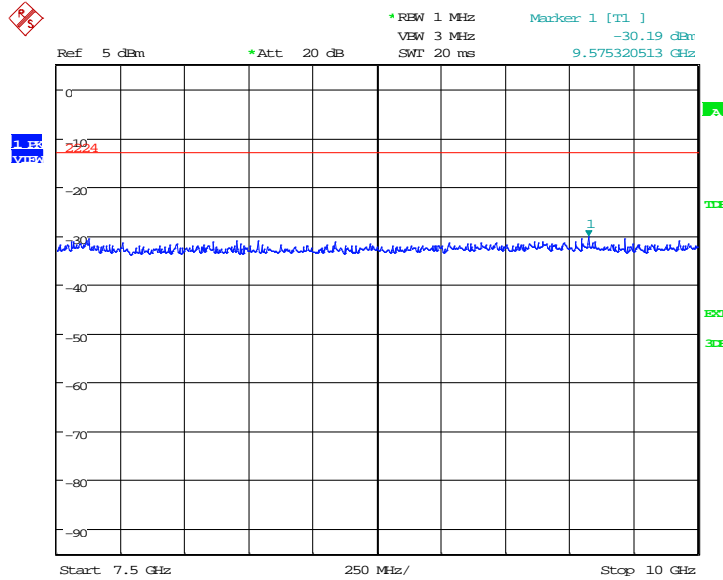

Date: 6.MAR.2019 05:45:12

Channel 190: 30MHz – 1GHz

Spurious emission limit –13dBm

NOTE: peak above the limit line is the carrier frequency.

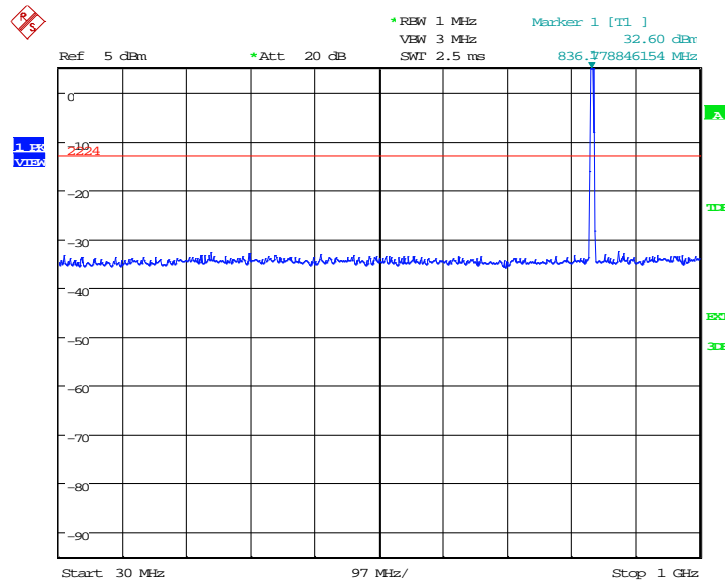

Date: 6.MAR.2019 05:45:39

Channel 190: 1GHz –2.5GHz

Spurious emission limit –13dBm

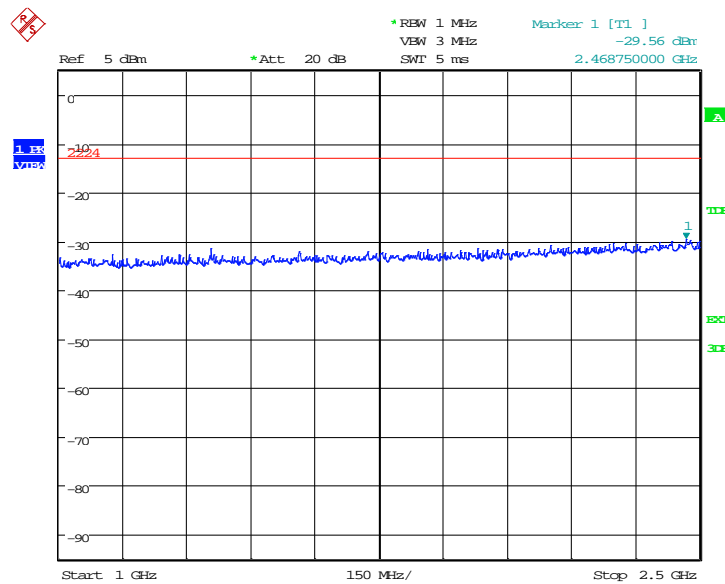

Date: 6.MAR.2019 05:46:06

Channel 190: 2.5GHz –7.5GHz
Spurious emission limit –13dBm

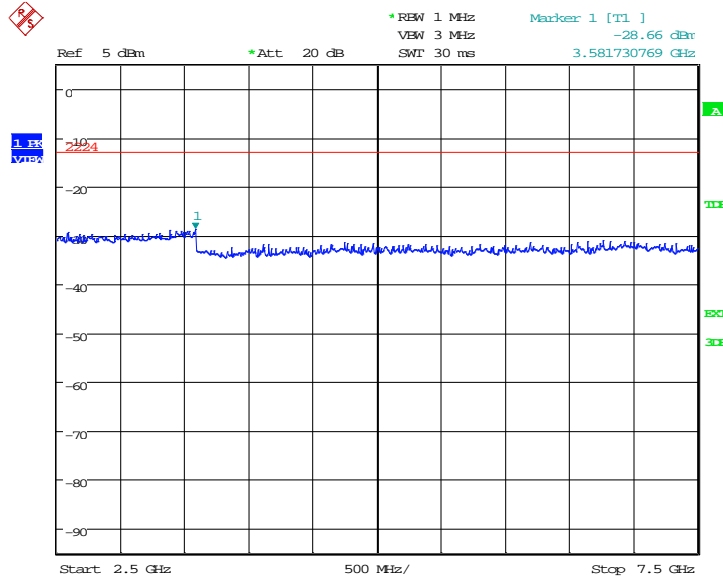

Date: 6.MAR.2019 05:46:33

Channel 190: 7.5GHz –10GHz
Spurious emission limit –13dBm

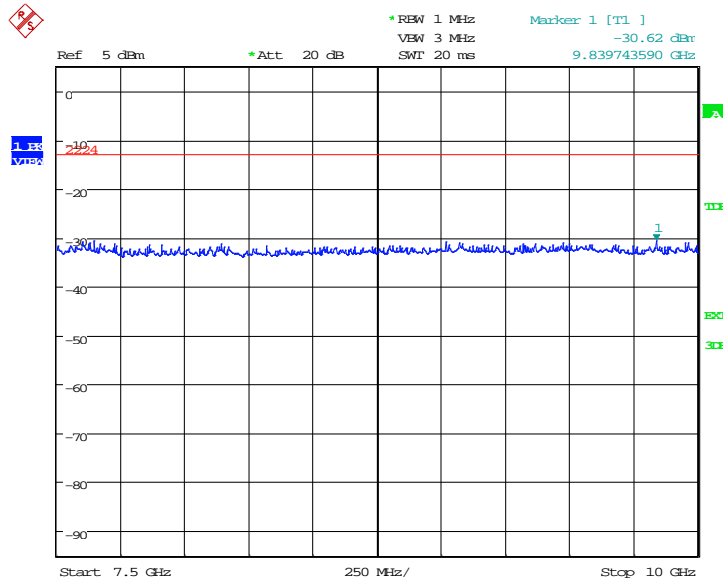

Date: 6.MAR.2019 05:47:00

Channel 251: 30MHz – 1GHz

Spurious emission limit –13dBm.

NOTE: peak above the limit line is the carrier frequency.

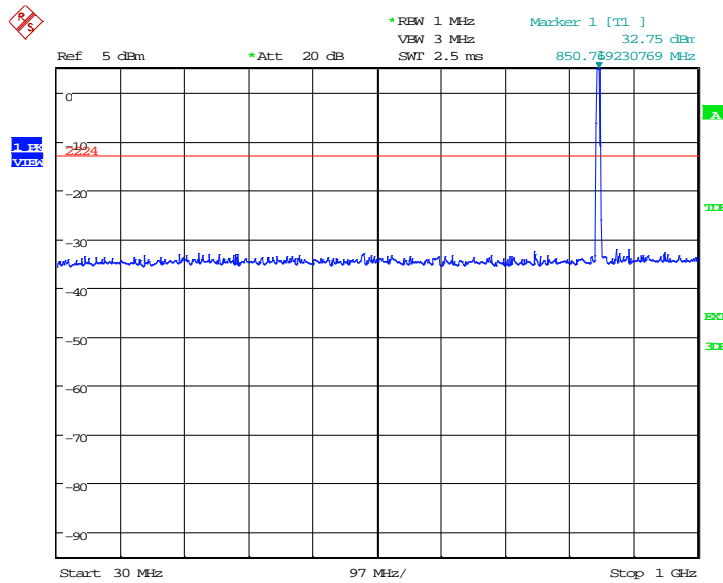

Date: 6.MAR.2019 05:47:27

Channel 251: 1GHz – 2.5GHz

Spurious emission limit –13dBm.

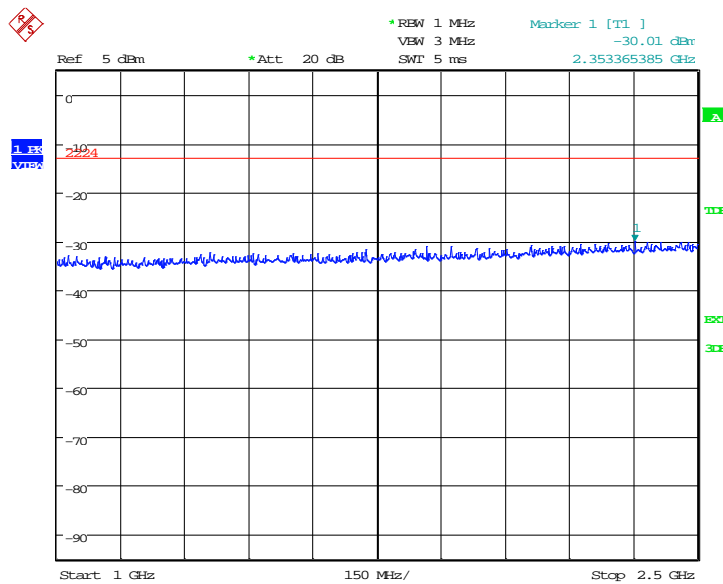

Date: 6.MAR.2019 05:47:54

Channel 251:2.5GHz – 7.5GHz
Spurious emission limit –13dBm.

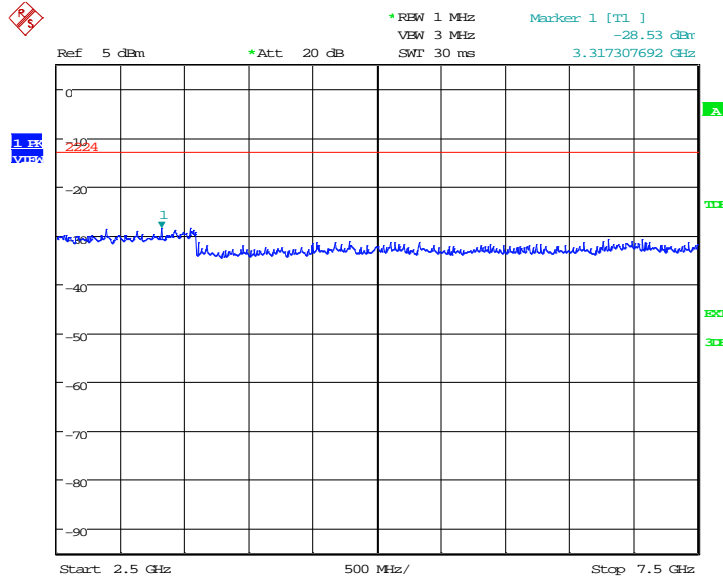

Date: 6.MAR.2019 05:48:21

Channel 251: 7.5GHz – 10GHz
Spurious emission limit –13dBm.

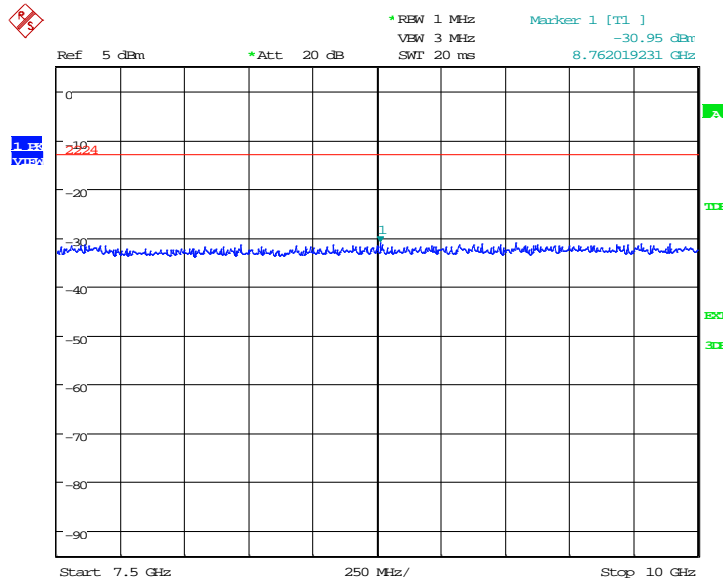

Date: 6.MAR.2019 05:48:48

GPRS1900

Channel 512: 30MHz – 1GHz

Spurious emission limit –13dBm.

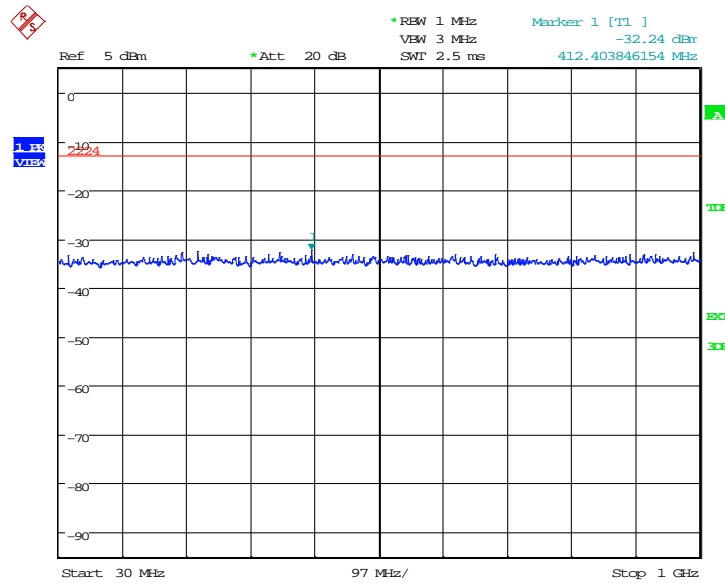

Date: 6.MAR.2019 06:01:26

Channel 512: 1GHz – 2.5GHz

Spurious emission limit –13dBm.

NOTE: peak above the limit line is the carrier frequency.

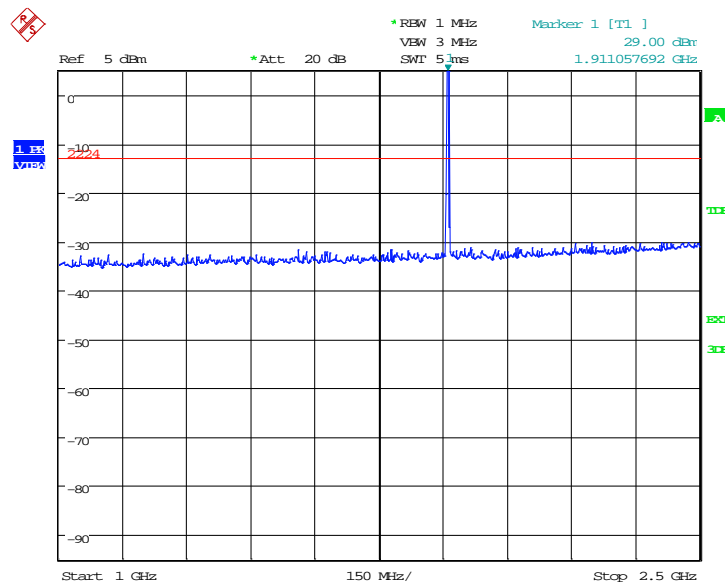

Date: 6.MAR.2019 06:01:53

Channel 512: 2.5GHz – 7.5GHz
Spurious emission limit –13dBm.

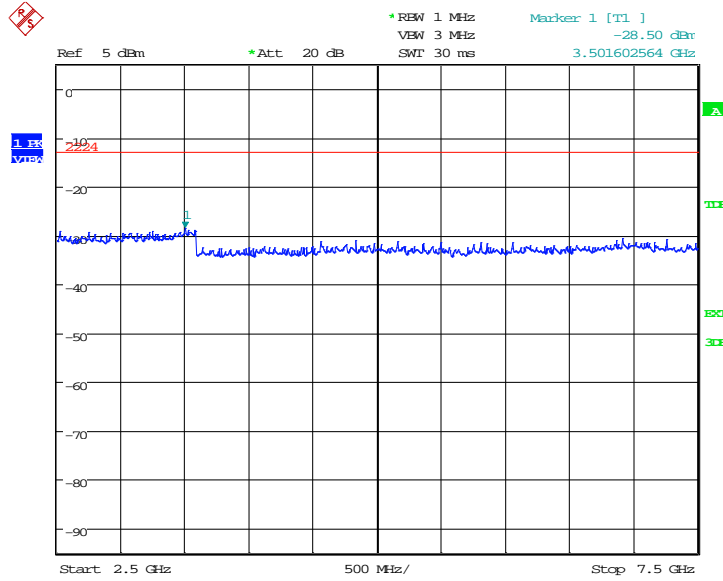

Date: 6.MAR.2019 06:02:20

Channel 512: 7.5GHz –10GHz
Spurious emission limit –13dBm.

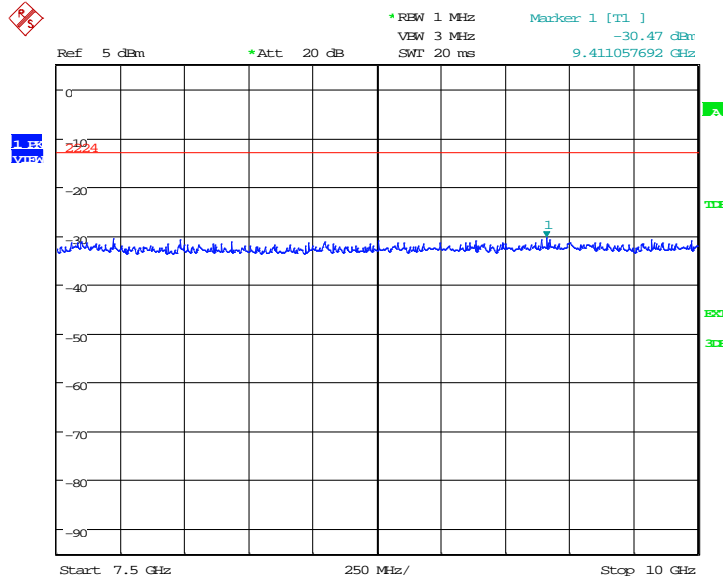

Date: 6.MAR.2019 06:02:47

Channel 512: 10GHz –15GHz
Spurious emission limit –13dBm.

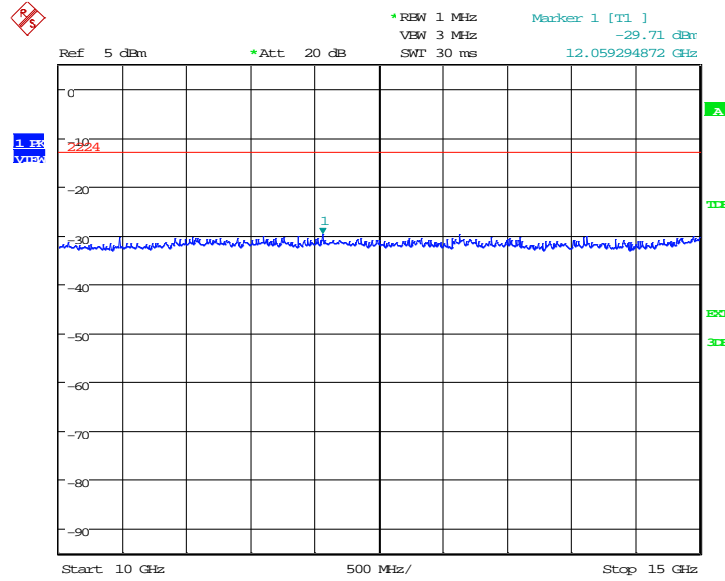

Date: 6.MAR.2019 06:03:14

Channel 512: 15GHz –20GHz
Spurious emission limit –13dBm.

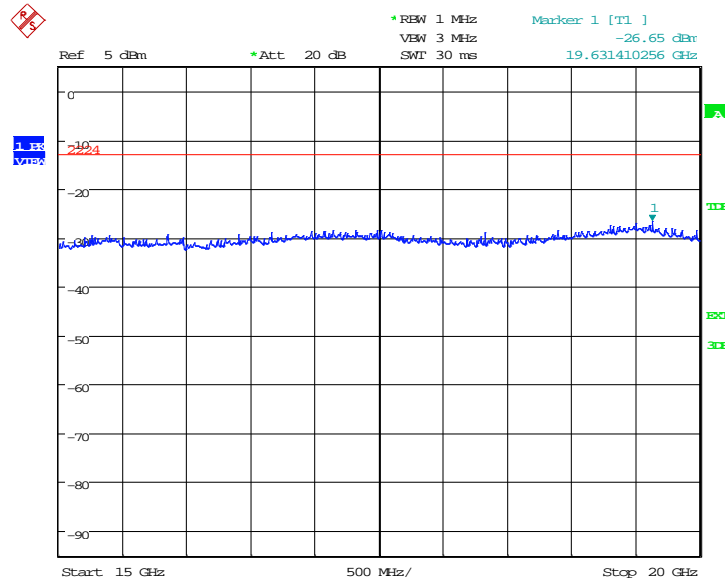

Date: 6.MAR.2019 06:03:41

Channel 661: 30MHz – 1GHz
Spurious emission limit –13dBm

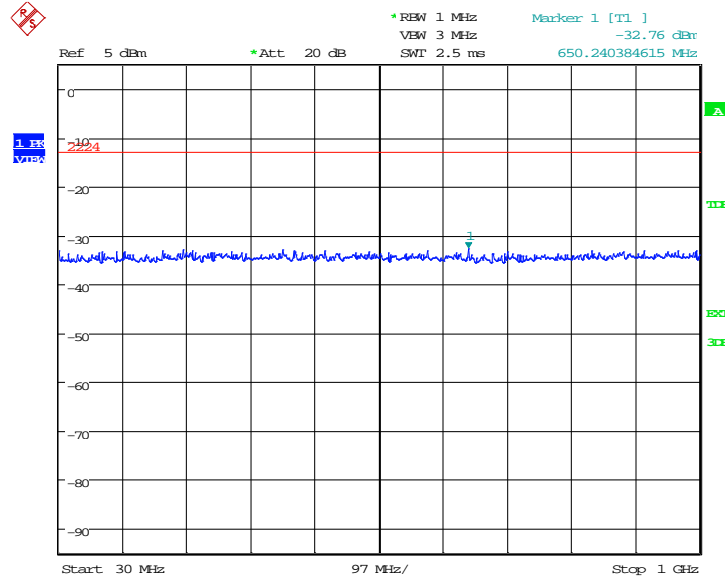

Date: 6.MAR.2019 06:04:08

Channel 661: 1GHz –2.5GHz
Spurious emission limit –13dBm

NOTE: peak above the limit line is the carrier frequency.

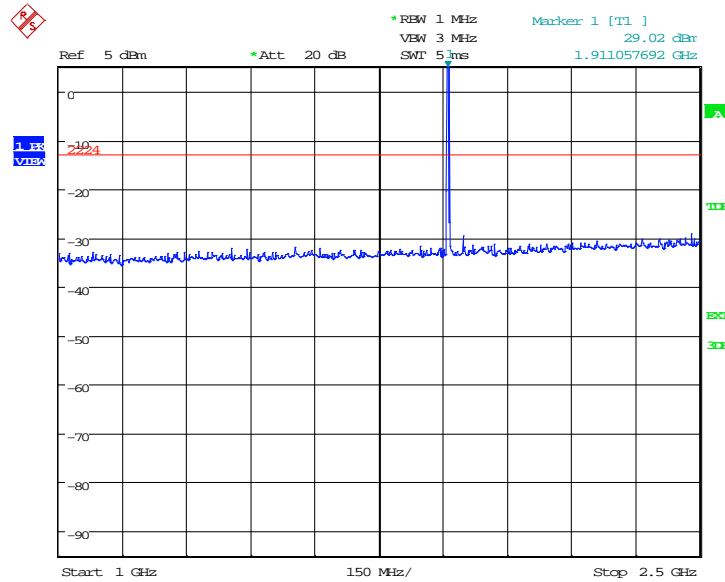

Date: 6.MAR.2019 06:04:35

Channel 661: 2.5GHz –7.5GHz
Spurious emission limit –13dBm

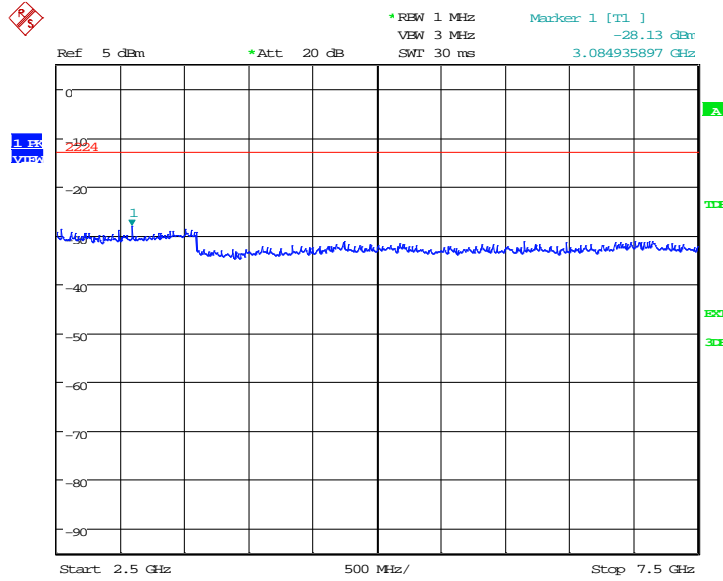

Date: 6.MAR.2019 06:05:01

Channel 661: 7.5GHz –10GHz
Spurious emission limit –13dBm

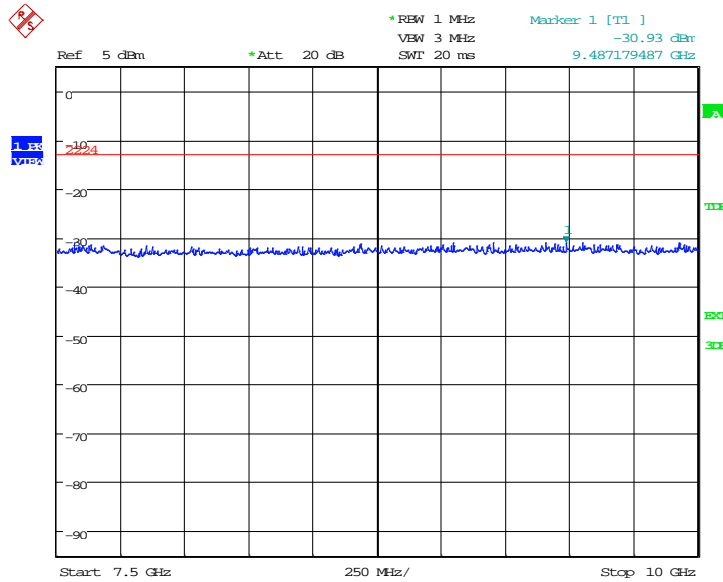

Date: 6.MAR.2019 06:05:28

Channel 661: 10GHz –15GHz
Spurious emission limit –13dBm.

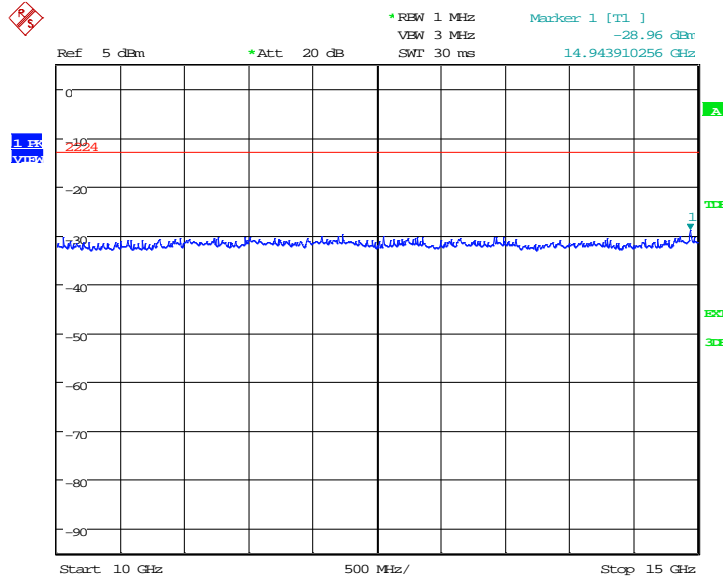

Date: 6.MAR.2019 06:05:55

Channel 661: 15GHz –20GHz
Spurious emission limit –13dBm.

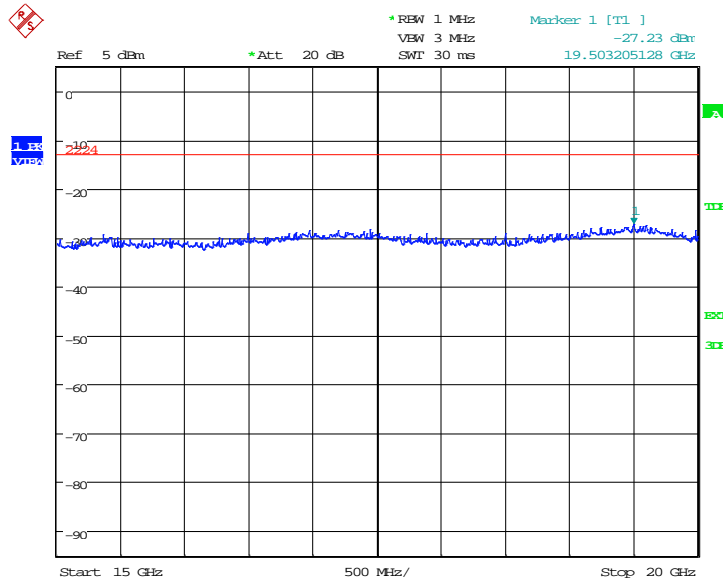

Date: 6.MAR.2019 06:06:22

Channel 810: 30MHz – 1GHz

Spurious emission limit –13dBm.

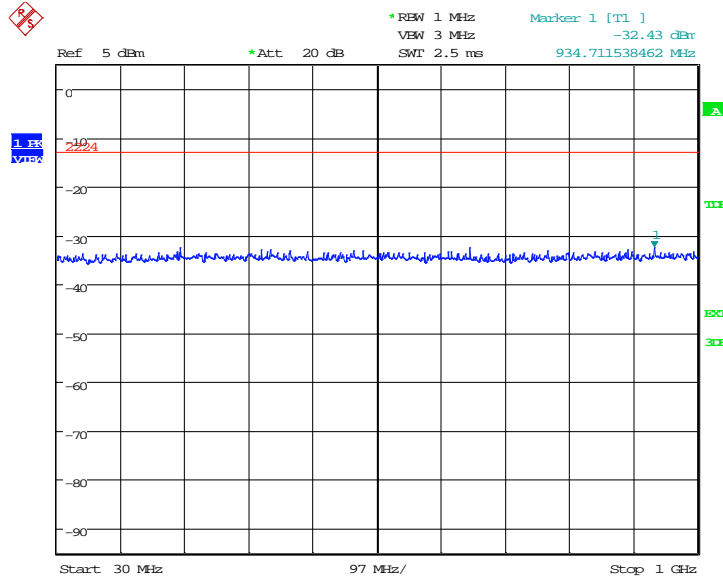

Date: 6.MAR.2019 06:06:49

Channel 810: 1GHz – 2.5GHz

Spurious emission limit –13dBm.

NOTE: peak above the limit line is the carrier frequency.

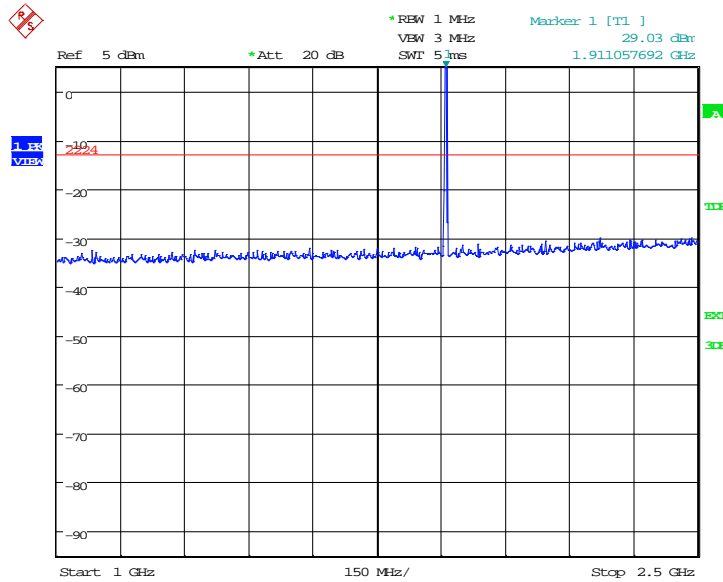

Date: 6.MAR.2019 06:07:16

Channel 810:2.5GHz – 7.5GHz
Spurious emission limit –13dBm.

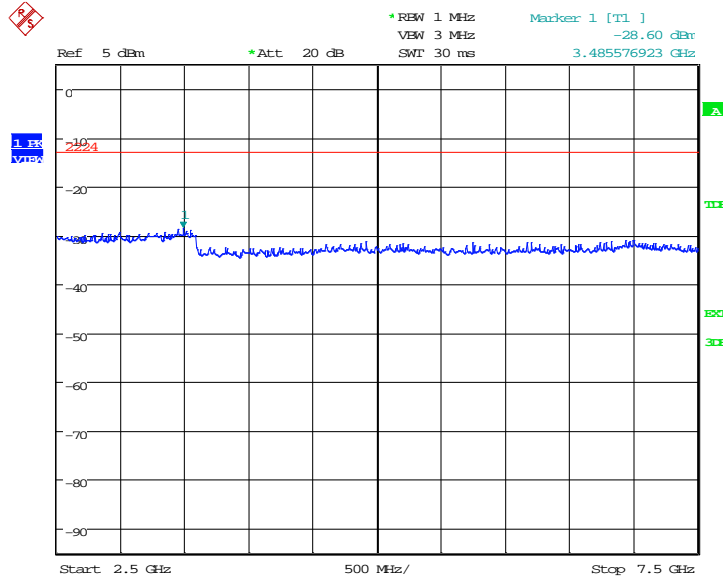

Date: 6.MAR.2019 06:07:43

Channel 810: 7.5GHz – 10GHz
Spurious emission limit –13dBm.

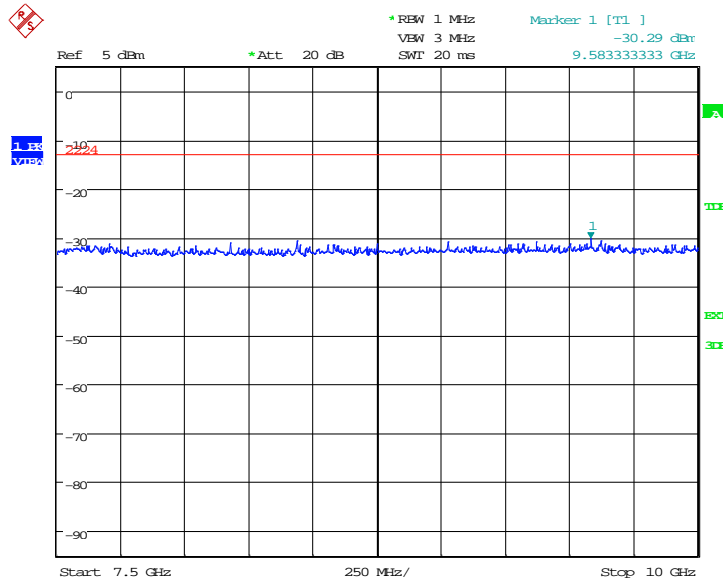

Date: 6.MAR.2019 06:08:10

Channel 810: 10GHz –15GHz

Spurious emission limit –13dBm.

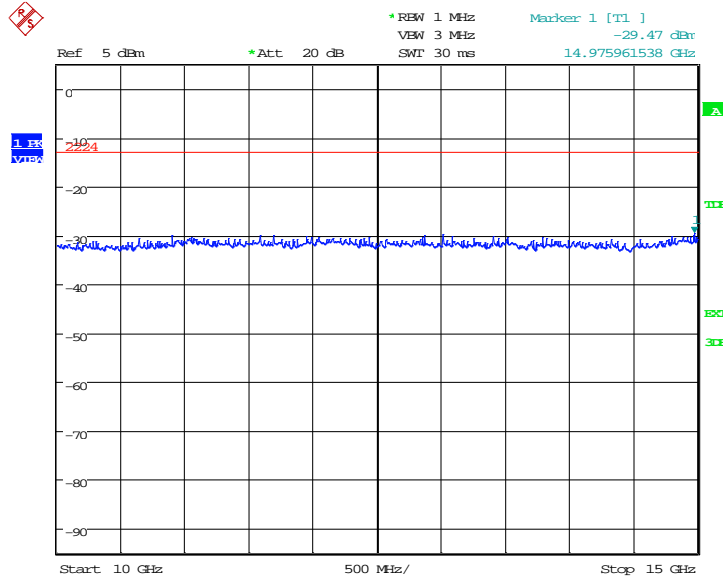

Date: 6.MAR.2019 06:08:37

Channel 810: 15GHz –20GHz

Spurious emission limit –13dBm.

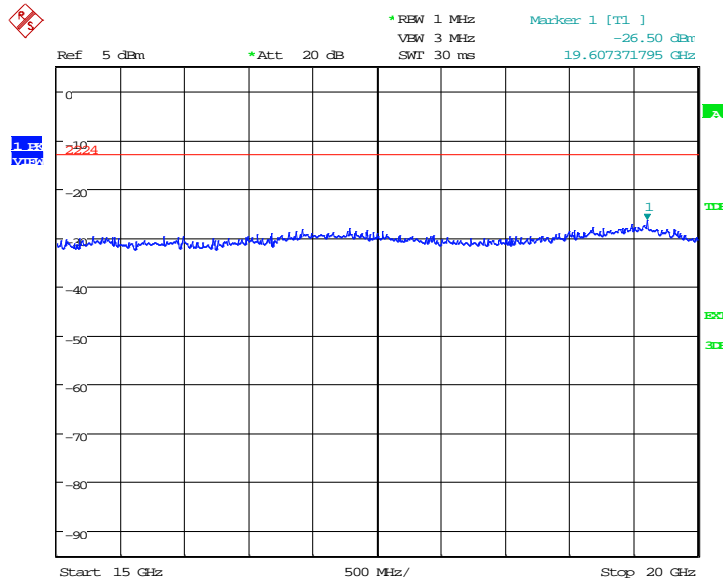

Date: 6.MAR.2019 06:09:04

Note: Expanded measurement uncertainty is $U = 0.488\text{dB}(100\text{KHz}-2\text{GHz})/1.211\text{dB}(2\text{GHz}-26.5\text{GHz})$, $k = 1.96$

*****END OF REPORT*****