



SGS-CSTC Standards Technical Services Co., Ltd. Shenzhen Branch

No. 1 Workshop, M-10, Middle section, Science & Technology Park,
Shenzhen, Guangdong, China 518057
Telephone: +86 (0) 755 2601 2053
Fax: +86 (0) 755 2671 0594
Email: ee.shenzhen@sgs.com

Report No.: SZEM170800874302
Page: 1 of 38

1 Cover Page

FCC Part 15C TEST REPORT

Application No.:	SZEM1708008743CR
Applicant:	ZIMI CORPORATION
FCC ID:	2AMIN- LYYX01ZM
Equipment Under Test (EUT):	NOTE: The following sample(s) was/were submitted and identified by the client as
Product Name:	Pocket Speaker
Model No.(EUT):	LYYX01ZM
Standards:	FCC PART 15 Subpart C: 2016
Date of Receipt:	2017-07-17
Date of Test:	2017-07-10 to 2017-08-30
Date of Issue:	2017-08-31
Test Result:	Pass*

*In the configuration tested, the EUT detailed in this report complied with the standards specified above.



Jack Zhang
EMC Laboratory Manager

The manufacturer should ensure that all products in series production are in conformity with the product sample detailed in this report. If the product in this report is used in any configuration other than that detailed in the report, the manufacturer must ensure the new system complies with all relevant standards. Any mention of SGS International Electrical Approvals or testing done by SGS International Electrical Approvals in connection with, distribution or use of the product described in this report must be approved by SGS International Electrical Approvals in writing.

This document is issued by the Company subject to its General Conditions of Service printed overleaf, available on request or accessible at www.sgs.com/terms_and_conditions.htm and, for electronic format documents, subject to Terms and Conditions for Electronic Documents at www.sgs.com/terms_e-document.htm. Attention is drawn to the limitation of liability, indemnification and jurisdiction issues defined therein. Any holder of this document is advised that information contained hereon reflects the Company's findings at the time of its intervention only and within the limits of Client's instructions, if any. The Company's sole responsibility is to its Client and this document does not exonerate parties to a transaction from exercising all their rights and obligations under the transaction. documents. This document cannot be reproduced except in full, without prior written approval of the Company. Any unauthorized alteration, forgery or falsification of the content or appearance of this document is unlawful and offenders may be prosecuted to the fullest extent of the law. Unless otherwise stated the results shown in this test report refer only to the sample(s) tested and such sample(s) are retained for 90 days only





**SGS-CSTC Standards Technical Services Co., Ltd.
Shenzhen Branch**

No. 1 Workshop, M-10, Middle section, Science & Technology Park,
Shenzhen, Guangdong, China 518057
Telephone: +86 (0) 755 2601 2053
Fax: +86 (0) 755 2671 0594
Email: ee.shenzhen@sgs.com

Report No.: SZEM170800874302
Page: 2 of 38

Revision Record				
Version	Chapter	Date	Modifier	Remark
00		2017-08-31		Original

Authorized for issue by:				
Tested By				2017-08-31
		_____		_____
		Foray Chen /Project Engineer		Date
Checked By				2017-08-31
		_____		_____
		Eric Fu /Reviewer		Date



SGS-CSTC Standards Technical Services Co., Ltd. Shenzhen Branch

No. 1 Workshop, M-10, Middle section, Science & Technology Park,
Shenzhen, Guangdong, China 518057
Telephone: +86 (0) 755 2601 2053
Fax: +86 (0) 755 2671 0594
Email: ee.shenzhen@sgs.com

Report No.: SZEM170800874302
Page: 3 of 38

2 Test Summary

Test Item	FCC Requirement	Test method	Result
Antenna Requirement	FCC Part 15, Subpart C Section 15.203/15.247 (c)	---	PASS
AC Power Line Conducted Emission	FCC Part 15, Subpart C Section 15.207	ANSI C63.10 (2013) Section 6.2	PASS
20dB Occupied Bandwidth	FCC Part 15, Subpart C Section 15.247 (a)(1)	ANSI C63.10 (2013) Section 6.9.2	PASS
Conducted Peak Output Power	FCC Part 15, Subpart C Section 15.247 (b)(1)	ANSI C63.10 (2013) Section 7.8.5	PASS
Carrier Frequencies Separation	FCC Part 15, Subpart C Section 15.247 (a)(1)	ANSI C63.10 (2013) Section 7.8.2	PASS
Hopping Channel Number	FCC Part 15, Subpart C Section 15.247 (a)(1)	ANSI C63.10 (2013) Section 7.8.3	PASS
Dwell Time	FCC Part 15, Subpart C Section 15.247 (a)(1)	ANSI C63.10 (2013) Section 7.8.4	PASS
Conducted Spurious Emissions and Band- edge	FCC Part 15, Subpart C Section 15.247(d)	ANSI C63.10 (2013) Section 7.8.6&7.8.8	PASS
Radiated Spurious Emissions and Band- edge	FCC Part 15, Subpart C Section 15.209&15.205	ANSI C63.10 (2013) Section 6.4&6.5&6.6&6.10	PASS

N/A: Not applicable, please refer to Section 7.3 of this report for details.



SGS-CSTC Standards Technical Services Co., Ltd. Shenzhen Branch

No. 1 Workshop, M-10, Middle section, Science & Technology Park,
Shenzhen, Guangdong, China 518057
Telephone: +86 (0) 755 2601 2053
Fax: +86 (0) 755 2671 0594
Email: ee.shenzhen@sgs.com

Report No.: SZEM170800874302
Page: 4 of 38

3 Contents

	Page
1 COVER PAGE	1
2 TEST SUMMARY	3
3 CONTENTS	4
4 GENERAL INFORMATION	5
4.1 CLIENT INFORMATION.....	5
4.2 GENERAL DESCRIPTION OF E.U.T.	5
4.3 TECHNICAL SPECIFICATIONS.....	5
4.4 DESCRIPTION OF SUPPORT UNITS.....	5
4.5 DETAILS OF TEST MODE	6
4.6 TEST LOCATION	6
4.7 TEST FACILITY	7
4.8 MEASUREMENT UNCERTAINTY	8
5 EQUIPMENTS LIST	9
6 ANTENNA REQUIREMENT	10
6.1 E.U.T. TEST CONDITIONS	10
6.2 FREQUENCY HOPPING SYSTEM REQUIREMENT	11
6.3 ANTENNA REQUIREMENT.....	12
6.4 CONDUCTED EMISSIONS ON MAINS TERMINALS	14
6.5 20DB OCCUPIED BANDWIDTH.....	18
6.6 CONDUCTED PEAK OUTPUT POWER.....	19
6.7 CARRIER FREQUENCIES SEPARATED	20
6.8 HOPPING CHANNEL NUMBER	21
6.9 DWELL TIME	22
6.10 CONDUCTED SPURIOUS EMISSIONS AND BAND EDGE	23
6.10.1 Conducted Spurious Emissions.....	23
6.10.2 Conducted Band-edge.....	23
6.11 RADIATED SPURIOUS EMISSIONS AND BAND-EDGE.....	24
6.11.1 Radiated Spurious Emissions.....	27
6.11.2 Radiated Band-edge.....	30
7 TEST SETUP PHOTOGRAPHS	38
8 EUT CONSTRUCTIONAL DETAILS	38



SGS-CSTC Standards Technical Services Co., Ltd. Shenzhen Branch

No. 1 Workshop, M-10, Middle section, Science & Technology Park,
Shenzhen, Guangdong, China 518057
Telephone: +86 (0) 755 2601 2053
Fax: +86 (0) 755 2671 0594
Email: ee.shenzhen@sgs.com

Report No.: SZEM170800874302
Page: 5 of 38

4 General Information

4.1 Client Information

Applicant:	ZIMI CORPORATION
Address of Applicant:	Room A913, No.159 Chengjiang Road, Jiangyin City, Jiangsu Province, 214431, P.R.C
Manufacturer:	ZIMI CORPORATION
Address of Manufacturer:	Room A913, No.159 Chengjiang Road, Jiangyin City, Jiangsu Province, 214431, P.R.C
Factory:	1. Tian Yu Communication Technology (KunShan) Co., Ltd. 2. Hangzhou Manko Technology Co., Ltd. 3. Tianjin Zowee Technology Development Co., Limited 4. Leung's Communication & Electric Products (Guangzhou) Ltd. 5. Kunshan Xuanchuang Electronic Co., Ltd
Address of Factory:	1. No.1 Jin Zhu Road, ,Lujia Town,Kunshan City,Jiangsu Province ,China 2. No.77 Chunchao Road, Xiaoshan Economic& Technological Development Zone, Hangzhou, China 3. No.71 South Street Xinhuan.West Zone.Economic Development Zone of Tianjin,Tianjin,China. 4. No. 39 Nanyunsan Road, Science Park, Hi-Tech Industrial Development Zone, Guangzhou, 510663, Guangdong, China 5. No.218 Changxing Ease Road, Zhoushi Town, KunShan City, Jiangsu Province, 215300, P.R.C.

4.2 General Description of E.U.T.

Product Name	Pocket Speaker
Model No.:	LYYX01ZM
Product Description:	Portable product with BT function
Battery:	DC 3.7V, 1200mAh rechargeable Li-ion battery
Test Voltage:	AC 120V, 60Hz

4.3 Technical Specifications

Operation Frequency:	2402MHz-2480MHz
Bluetooth Version:	BT 4.1 classic mode
Modulation Type:	GFSK, $\pi/4$ DQPSK,8DPSK
Number of Channel:	79
Antenna Type	PCB Antenna
Antenna Gain	-1.71dBi

4.4 Description of Support Units

The EUT has been tested with associated equipment below.



SGS-CSTC Standards Technical Services Co., Ltd. Shenzhen Branch

No. 1 Workshop, M-10, Middle section, Science & Technology Park,
Shenzhen, Guangdong, China 518057
Telephone: +86 (0) 755 2601 2053
Fax: +86 (0) 755 2671 0594
Email: ee.shenzhen@sgs.com

Report No.: SZEM170800874302
Page: 6 of 38

Description	Manufacturer	Model No.	Supplied by
Laptop	Lenovo	ThinkPad X100e	SGS
BT test board	/	/	Client
Adapter	Apple	A1402	SGS

Parameter of adapter:

Adapter:	Manufacturer:	Apple	
	Model No.:	A1402	
	Rated Input:	AC 100~240V 50~60Hz 0.15A	
	Rated Output:	DC 5.0V 1A	
	Cable length:	AC port:	/
DC port:		50 cm	

Software name	Manufacturer	Version	Supplied By
Blue Test3 (For CSR)	/	2.5.0	SGS

4.5 Details of Test Mode

Test Mode	Description of Test Mode
Hopping disabled mode	Using test software to control EUT working in continuous transmitting, and select channel and modulation type.
Hopping enabled mode	Using test software to control EUT working in continuous transmitting, and hopping on status.

4.6 Test Location

All tests were performed at:

SGS-CSTC Standards Technical Services Co., Ltd., Shenzhen Branch

No. 1 Workshop, M-10, Middle Section, Science & Technology Park, Shenzhen, Guangdong, China.

518057

Tel: +86 755 2601 2053

Fax: +86 755 2671 0594

No tests were sub-contracted.



SGS-CSTC Standards Technical Services Co., Ltd. Shenzhen Branch

No. 1 Workshop, M-10, Middle section, Science & Technology Park,
Shenzhen, Guangdong, China 518057
Telephone: +86 (0) 755 2601 2053
Fax: +86 (0) 755 2671 0594
Email: ee.shenzhen@sgs.com

Report No.: SZEM170800874302
Page: 7 of 38

4.7 Test Facility

The test facility is recognized, certified, or accredited by the following organizations:

- **CNAS (No. CNAS L2929)**

CNAS has accredited SGS-CSTC Standards Technical Services Co., Ltd. Shenzhen Branch EMC Lab to ISO/IEC 17025:2005 General Requirements for the Competence of Testing and Calibration Laboratories (CNAS-CL01 Accreditation Criteria for the Competence of Testing and Calibration Laboratories) for the competence in the field of testing.

- **A2LA (Certificate No. 3816.01)**

SGS-CSTC Standards Technical Services Co., Ltd., Shenzhen EMC Laboratory is accredited by the American Association for Laboratory Accreditation(A2LA). Certificate No. 3816.01.

- **VCCI**

The 10m Semi-anechoic chamber and Shielded Room of SGS-CSTC Standards Technical Services Co., Ltd. have been registered in accordance with the Regulations for Voluntary Control Measures with Registration No.: G-823, R-4188, T-1153 and C-2383 respectively.

- **FCC –Designation Number: CN1178**

SGS-CSTC Standards Technical Services Co., Ltd., Shenzhen EMC Laboratory has been recognized as an accredited testing laboratory.

Designation Number: CN1178. Test Firm Registration Number: 406779.

- **Industry Canada (IC)**

Two 3m Semi-anechoic chambers and the 10m Semi-anechoic chamber of SGS-CSTC Standards Technical Services Co., Ltd. Shenzhen Branch EMC Lab have been registered by Certification and Engineering Bureau of Industry Canada for radio equipment testing with Registration No.: 4620C-1, 4620C-2, 4620C-3.



SGS-CSTC Standards Technical Services Co., Ltd. Shenzhen Branch

No. 1 Workshop, M-10, Middle section, Science & Technology Park,
Shenzhen, Guangdong, China 518057
Telephone: +86 (0) 755 2601 2053
Fax: +86 (0) 755 2671 0594
Email: ee.shenzhen@sgs.com

Report No.: SZEM170800874302
Page: 8 of 38

4.8 Measurement Uncertainty

No.	Parameter	Measurement Uncertainty
1	Radio Frequency	$< \pm 1 \times 10^{-5}$
2	Total RF power, conducted	$< \pm 1.5$ dB
3	RF power density, conducted	$< \pm 3$ dB
4	Spurious emissions, conducted	$< \pm 3$ dB
5	All emissions, radiated	$< \pm 6$ dB (Below 1GHz) $< \pm 6$ dB (Above 1GHz)
6	Temperature	$< \pm 1^{\circ}\text{C}$
7	Humidity	$< \pm 5$ %
8	DC and low frequency voltages	$< \pm 3$ %



SGS-CSTC Standards Technical Services Co., Ltd. Shenzhen Branch

No. 1 Workshop, M-10, Middle section, Science & Technology Park,
Shenzhen, Guangdong, China 518057
Telephone: +86 (0) 755 2601 2053
Fax: +86 (0) 755 2671 0594
Email: ee.shenzhen@sgs.com

Report No.: SZEM170800874302
Page: 9 of 38

5 Equipments List

Item	Test Equipment	Manufacturer	Model No.	Serial No.	Cal. Date	Cal. Due date
1	Power meter	Rohde & Schwarz	NRP	101641	2017-01-14	2018-01-13
2	Power Sensor	Rohde & Schwarz	NRP-Z22	101096	2017-08-06	2018-08-05
3	Spectrum Analyzer	Rohde & Schwarz	FSP-30	2705121009	2017-01-14	2018-01-13
4	EMI test receiver	Rohde & Schwarz	ESU40	100109	2017-02-13	2018-01-15
5	Active Loop Antenna (9kHz to 30MHz)	Rohde & Schwarz	FMZB1519	1519-034	2017-02-13	2018-01-15
6	Broadband UHF-VHF ANTENNA (25MHz to 2GHz)	SCHWARZBECK	VULB9168	9168-313	2017-02-13	2018-01-15
7	Ultra broadband antenna (25MHz to 3GHz)	Rohde & Schwarz	HL562	100227	2017-08-30	2018-08-29
8	Horn Antenna (1GHz to 18GHz)	Rohde & Schwarz	HF906	100284	2017-02-13	2018-01-15
9	Horn Antenna (1GHz to 18GHz)	SCHWARZBECK	BBHA9120D	9120D-679	2017-02-13	2018-01-15
10	Horn Antenna(14GHz to 40GHz)	SCHWARZBECK	BBHA 9170	BBHA917-0373	2017-02-13	2018-01-15
11	Pre-amplifier (9KHz – 2GHz)	LNA6900	TESEQ	71033	/	/
12	Pre-amplifier (1GHz – 26.5GHz)	SCHWARZBECK	SCU-F0118- G40-BZ4- CSS(F)	10001	2017-01-14	2018-01-13
13	Pre-amplifier (14GHz – 40GHz)	SCHWARZBECK	SCU-F1840- G35-BZ3- CSS(F)	10001	2017-01-14	2018-01-13
14	Tunable Notch Filter	Wainwright instruments GmbH	WRCT800.0/880 .0-0.2/40-5SSK	170397 169777 169780 192507	/	/
15	High pass Filter	FSCW	HP 12/2800- 5AA2	19A45-02	/	/
16	High-low temperature cabinet	Suzhou Zhihe	TL-40	50110050	2016-09-11	2017-09-10
17	AC power stabilizer	WOCEN	6100	51122	2017-01-14	2018-01-13
18	DC power	QJE	QJ30003SII	3573/4/3	2017-01-14	2018-01-13
19	Signal Generator (Interferer)	Rohde & Schwarz	SMR40	100555	2017-08-13	2018-08-12
20	Signal Generator (Blocker)	Rohde & Schwarz	SMJ100A	101394	2017-01-14	2018-01-13
21	Splitter	Anritsu	MA1612A	M12265	/	/
22	Coupler	e-meca	803-S-1	900-M01	/	/



No. 1 Workshop, M-10, Middle section, Science & Technology Park,
Shenzhen, Guangdong, China 518057
Telephone: +86 (0) 755 2601 2053
Fax: +86 (0) 755 2671 0594
Email: ee.shenzhen@sgs.com

Report No.: SZEM170800874302
Page: 10 of 38

6 Antenna Requirement

6.1 E.U.T. test conditions

Requirements: 15.31(e) For intentional radiators, measurements of the variation of the input power or the radiated signal level of the fundamental frequency component of the emission, as appropriate, shall be performed with the supply voltage varied between 85% and 115% of the nominal rated supply voltage. For battery operated equipment, the equipment tests shall be performed using a new battery.

Operating Environment:	Temperature:	20.0 -25.0 °C
	Humidity:	35-75 % RH
	Atmospheric Pressure:	99.2 -102 kPa

Test frequencies: According to the 15.31(m) Measurements on intentional radiators or receivers, other than TV broadcast receivers, shall be performed and, if required, reported for each band in which the device can be operated with the device operating at the number of frequencies in each band specified in the following table:

Frequency range over which device operates	Number of frequencies	Location in the range of operation
1 MHz or less	1	Middle
1 to 10 MHz	2	1 near top and 1 near bottom
More than 10 MHz	3	1 near top, 1 near middle and 1 near bottom

Pursuant to Part 15.31(c) For swept frequency equipment, measurements shall be made with the frequency sweep stopped at those frequencies chosen for the measurements to be reported.

Test frequency is the lowest channel: 0 channel (2402MHz), middle channel: 39 channel (2441MHz) and highest channel: 78 channel (2480MHz) with fixed at channel.

6.2 Frequency Hopping System Requirement

Test Requirement: Section 15.247 (a)(1), (g), (h) requirement:

The system shall hop to channel frequencies that are selected at the system hopping rate from a Pseudorandom ordered list of hopping frequencies. Each frequency must be used equally on the average by each transmitter. The system receivers shall have input bandwidths that match the hopping channel bandwidths of their corresponding transmitters and shall shift frequencies in synchronization with the transmitted signals.

Frequency hopping spread spectrum systems are not required to employ all available hopping channels during each transmission. However, the system, consisting of both the transmitter and the receiver, must be designed to comply with all of the regulations in this section should the transmitter be presented with a continuous data (or information) stream. In addition, a system employing short transmission bursts must comply with the definition of a frequency hopping system and must distribute its transmissions over the minimum number of hopping channels specified in this section.

The incorporation of intelligence within a frequency hopping spread spectrum system that permits the system to recognize other users within the spectrum band so that it individually and independently chooses and adapts its hop sets to avoid hopping on occupied channels is permitted. The coordination of frequency hopping systems in any other manner for the express purpose of avoiding the simultaneous occupancy of individual hopping frequencies by multiple transmitters is not permitted.

Compliance for section 15.247(a)(1)

According to Bluetooth Core Specification, the pseudorandom sequence may be generated in a nine-stage shift register whose 5th and 9th stage outputs are added in a modulo-two addition stage. And the result is fed back to the input of the first stage. The sequence begins with the first ONE of 9 consecutive ONES; i.e. the shift register is initialized with nine ones.

- Number of shift register stages: 9
- Length of pseudo-random sequence: $2^9 - 1 = 511$ bits
- Longest sequence of zeros: 8 (non-inverted signal)

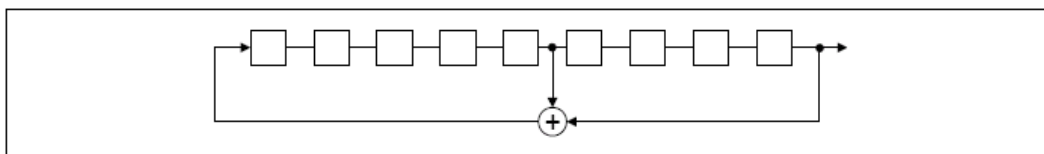

Linear Feedback Shift Register for Generation of the PRBS sequence

An example of Pseudorandom Frequency Hopping Sequence as follow:

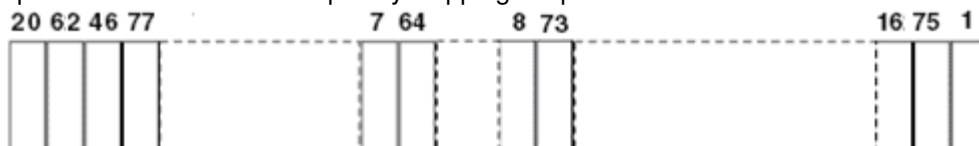

Each frequency used equally on the average by each transmitter.

According to Bluetooth Core Specification, Bluetooth receivers are designed to have input and IF bandwidths that match the hopping channel bandwidths of any Bluetooth transmitters and shift frequencies in synchronization with the transmitted signals.



SGS-CSTC Standards Technical Services Co., Ltd. Shenzhen Branch

No. 1 Workshop, M-10, Middle section, Science & Technology Park,
Shenzhen, Guangdong, China 518057
Telephone: +86 (0) 755 2601 2053
Fax: +86 (0) 755 2671 0594
Email: ee.shenzhen@sgs.com

Report No.: SZEM170800874302
Page: 12 of 38

Compliance for section 15.247(g)

According to Bluetooth Core Specification, the Bluetooth system transmits the packet with the pseudorandom hopping frequency with a continuous data and the short burst transmission from the Bluetooth system is also transmitted under the frequency hopping system with the pseudorandom hopping frequency system.

Compliance for section 15.247(h)

According to Bluetooth Core specification, the Bluetooth system incorporates with an adaptive system to detect other user within the spectrum band so that it individually and independently to avoid hopping on the occupied channels.

According to the Bluetooth Core specification, the Bluetooth system is designed not have the ability to coordinate with other FHSS System in an effort to avoid the simultaneous occupancy of individual hopping frequencies by multiple transmitter.

6.3 Antenna Requirement

Standard requirement:

15.203 requirement:

An intentional radiator shall be designed to ensure that no antenna other than that furnished by the responsible party shall be used with the device. The use of a permanently attached antenna or of an antenna that uses a unique coupling to the intentional radiator, the manufacturer may design the unit so that a broken antenna can be replaced by the user, but the use of a standard antenna jack or electrical connector is prohibited.

15.247(b) (4) requirement:

The conducted output power limit specified in paragraph (b) of this section is based on the use of antennas with directional gains that do not exceed 6 dBi. Except as shown in paragraph (c) of this section, if transmitting antennas of directional gain greater than 6 dBi are used, the conducted output power from the intentional radiator shall be reduced below the stated values in paragraphs (b)(1), (b)(2), and (b)(3) of this section, as appropriate, by the amount in dB that the directional gain of the antenna exceeds 6 dBi.

EUT Antenna:

The antenna is PCB antenna and no consideration of replacement. The gain of the antenna is -1.71dBi.

No. 1 Workshop, M-10, Middle section, Science & Technology Park,
Shenzhen, Guangdong, China 518057
Telephone: +86 (0) 755 2601 2053
Fax: +86 (0) 755 2671 0594
Email: ee.shenzhen@sgs.com

Report No.: SZEM170800874302
Page: 13 of 38

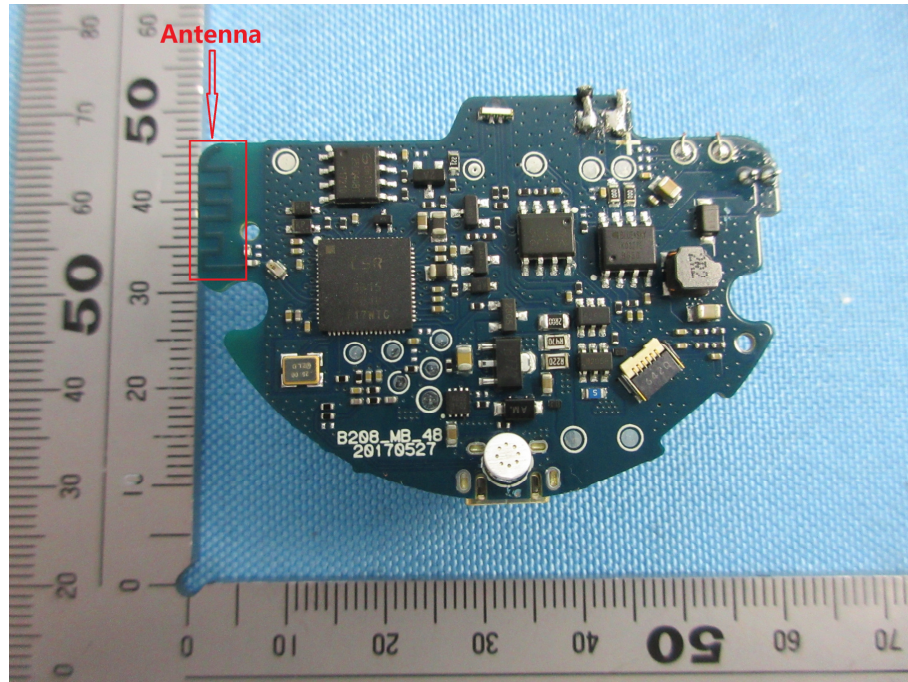

6.4 Conducted Emissions on Mains Terminals

Frequency Range: 150 KHz to 30 MHz

Limit:

Frequency range MHz	Class B Limits: dB (μV)	
	Quasi-peak	Average
0.15 to 0.50	66 to 56	56 to 46
0.50 to 5	56	46
5 to 30	60	50

Note1: The limit decreases linearly with the logarithm of the frequency in the range 0.15 MHz to 0.50MHz.

Note2: The lower limit is applicable at the transition frequency.

Test Setup:

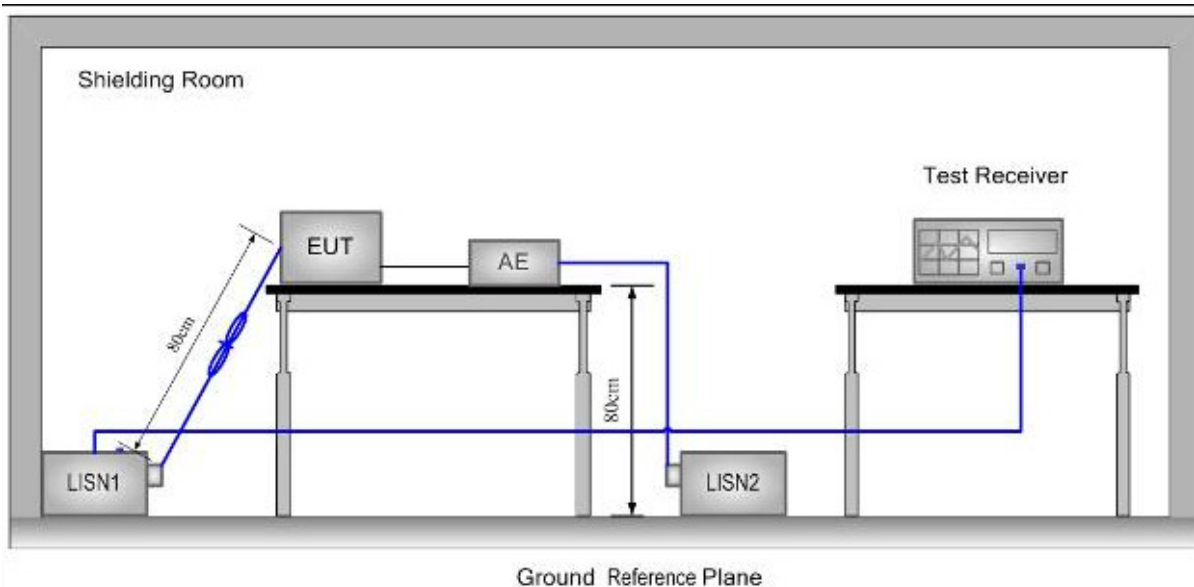

Test Procedure:

- 1) The mains terminal disturbance voltage was measured with the EUT in a shielded room.
- 2) The EUT was connected to AC power source through a LISN 1 (Line Impedance Stabilization Network) which provides $50\Omega/50\mu\text{H} + 5\Omega$ linear impedance. The power cables of all other units of the EUT were connected to a second LISN, which was bonded to the ground reference plane in the same way as the LISN for the unit being measured. A multiple socket outlet strip was used to connect multiple power cables to a single LISN provided the rating of the LISN was not exceeded.
- 3) The tabletop EUT was placed upon a non-metallic table 0.8m above the ground reference plane. And for floor-standing arrangement, the EUT was placed on the horizontal ground reference plane, but separated from metallic contact with the ground reference plane by 0.1m of insulation.
- 4) The test was performed with a vertical ground reference plane. The rear of the EUT shall be 0.4 m from the vertical ground reference plane. The vertical ground reference plane was bonded to the horizontal ground reference plane. The LISN was placed 0.8 m from the boundary of the unit under test and bonded to a ground reference plane for LISN mounted on top of the ground



SGS-CSTC Standards Technical Services Co., Ltd. Shenzhen Branch

No. 1 Workshop, M-10, Middle section, Science & Technology Park,
Shenzhen, Guangdong, China 518057
Telephone: +86 (0) 755 2601 2053
Fax: +86 (0) 755 2671 0594
Email: ee.shenzhen@sgs.com

Report No.: SZEM170800874302
Page: 15 of 38

reference plane. This distance was between the closest points of the LISN and the EUT. The mains lead of EUT excess 0.8m was folded back and forth parallel to the lead so as to form a horizontal bundle with a length between 0.3m and 0.4m. All other units of the EUT and associated equipment were at least 0.8 m from the LISN.

Remark: Pre-scan was performed with peak detected on all ports, Quasi-peak & average measurements were performed at the frequencies at which maximum peak emission level were detected. Pretest under all modes; choose the worst case mode (in Middle channel) record on the report. Please see the attached Quasi-peak and Average test results.

Test Result: PASS



SGS-CSTC Standards Technical Services Co., Ltd. Shenzhen Branch

No. 1 Workshop, M-10, Middle section, Science & Technology Park,
Shenzhen, Guangdong, China 518057
Telephone: +86 (0) 755 2601 2053
Fax: +86 (0) 755 2671 0594
Email: ee.shenzhen@sgs.com

Report No.: SZEM170800874302
Page: 16 of 38

Test Data:

Test Mode:	Hopping	Test Channel:	N/A
Test Port:	AC Live Line		

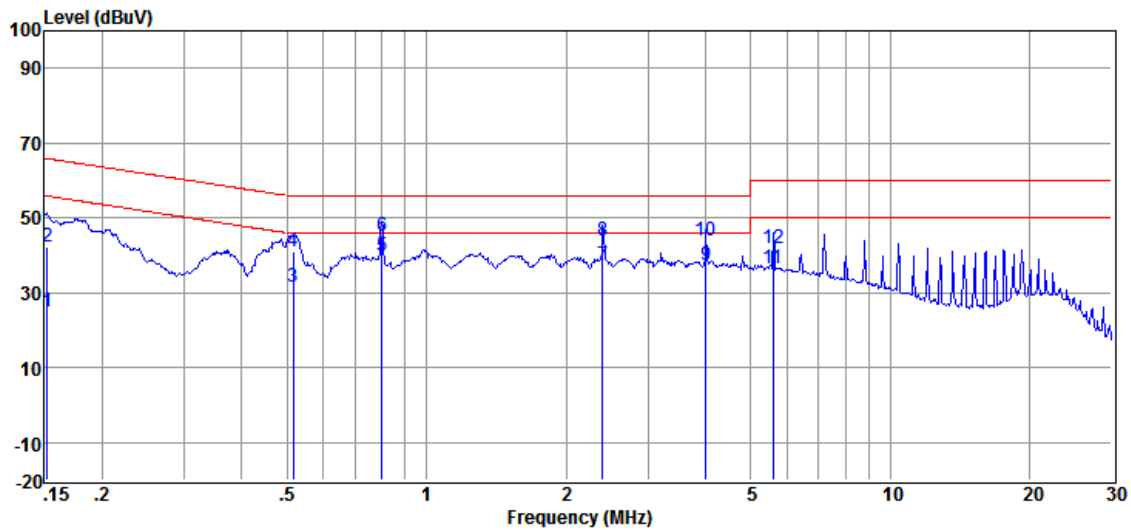

Item	Freq.	Read Level	LISN Factor	Cable Loss	Level	Limit Line	Over Limit	Detector
(Mark)	(MHz)	(dB μ V)	(dB)	(dB)	(dB μ V)	(dB μ V)	(dB)	
1	0.152	15.01	0.11	9.81	24.93	55.87	-30.94	Average
2	0.152	32.50	0.11	9.81	42.42	65.87	-23.45	QP
3	0.516	21.80	0.11	9.82	31.73	46.00	-14.27	Average
4	0.516	31.26	0.11	9.82	41.19	56.00	-14.81	QP
5	0.800	29.87	0.11	9.83	39.81	46.00	-6.19	Average
6	0.800	35.27	0.11	9.83	45.21	56.00	-10.79	QP
7	2.396	27.21	0.12	9.85	37.18	46.00	-8.82	Average
8	2.396	33.91	0.12	9.85	43.88	56.00	-12.12	QP
9	4.006	27.45	0.12	9.85	37.42	46.00	-8.58	Average
10	4.006	34.00	0.12	9.85	43.97	56.00	-12.03	QP
11	5.594	26.71	0.11	9.86	36.68	50.00	-13.32	Average
12	5.594	31.78	0.11	9.86	41.75	60.00	-18.25	QP

Test Port: AC Neutral Line

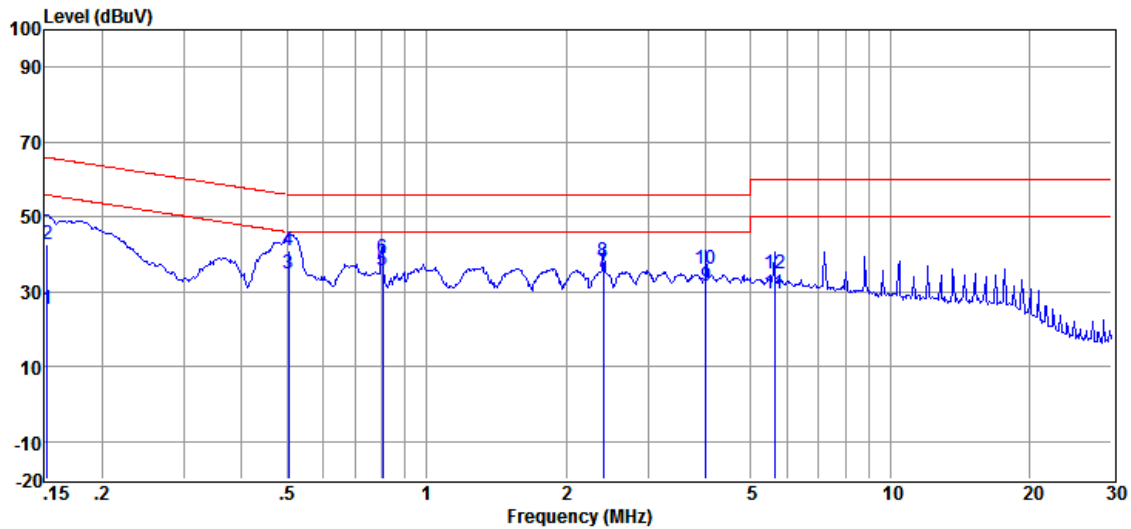

Item	Freq.	Read Level	LISN Factor	Cable Loss	Level	Limit Line	Over Limit	Detector
(Mark)	(MHz)	(dB μ V)	(dB)	(dB)	(dB μ V)	(dB μ V)	(dB)	
1	0.152	15.53	0.12	9.81	25.46	55.87	-30.41	Average
2	0.152	32.90	0.12	9.81	42.83	65.87	-23.04	QP
3	0.505	24.77	0.11	9.82	34.70	46.00	-11.30	Average
4	0.505	31.13	0.11	9.82	41.06	56.00	-14.94	QP
5	0.804	25.87	0.11	9.83	35.81	46.00	-10.19	Average
6	0.804	28.98	0.11	9.83	38.92	56.00	-17.08	QP
7	2.409	25.40	0.13	9.85	35.38	46.00	-10.62	Average
8	2.409	28.32	0.13	9.85	38.30	56.00	-17.70	QP
9	4.006	21.37	0.13	9.85	31.35	46.00	-14.65	Average
10	4.006	26.30	0.13	9.85	36.28	56.00	-19.72	QP
11	5.623	19.56	0.13	9.86	29.55	50.00	-20.45	Average
12	5.623	25.05	0.13	9.86	35.04	60.00	-24.96	QP

Remark: Level = Read Level + LISN/ISN Factor + Cable Loss.

6.5 20dB Occupied Bandwidth

Test Configuration:

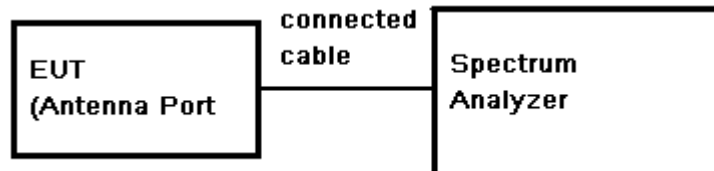

Test Procedure:

1. Remove the antenna from the EUT and then connect a low RF cable from the antenna port to the spectrum;
2. Set the spectrum analyzer: Span = approximately 2 to 5 times the OBW, centred on the hopping channel;
3. Set the spectrum analyzer: RBW \geq 1% to 5% of the OBW (set 30 kHz). VBW \geq RBW. Sweep = Auto; Detector = Peak. Trace = Max Hold.
4. Mark the peak frequency and -20dB points.

Test Date:

Appendix for SZEM170800874302

6.6 Conducted Peak Output Power

Test Configuration:

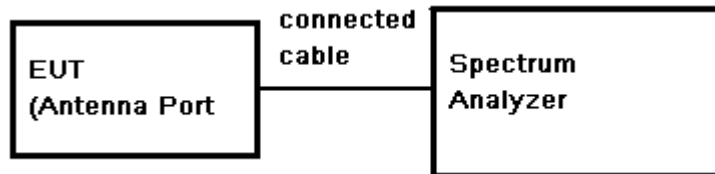

Test Procedure:

1. Remove the antenna from the EUT and then connect a low RF cable from the antenna port to the spectrum.
2. Set the spectrum analyzer: RBW = 3 MHz, VBW = 8 MHz; Span: Approximately five times the 20 dB bandwidth; Sweep = auto; Detector Function = Peak.
3. Keep the EUT in transmitting at lowest, middle and highest channel individually. Record the max value.

Test Limit:

Regulation 15.247 (b)(1) For frequency hopping systems operating in the 2400-2483.5 MHz band employing at least 75 non-overlapping hopping channels, and all frequency hopping systems in the 5725-5850 MHz band: 1 watt. For all other frequency hopping systems in the 2400-2483.5 MHz band: 0.125 watts. Refer to the result "Hopping channel number" of this document. The 0.125 watt (21 dBm) limit applies.

Test Data:

Appendix for SZEM170800874302

6.7 Carrier Frequencies Separated

Test Configuration:

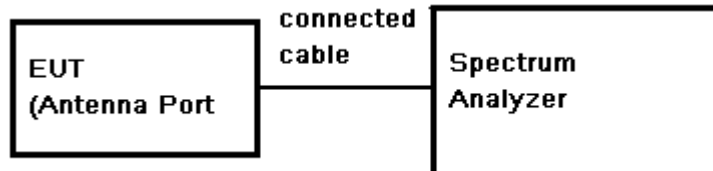

Test Procedure:

- 1) Remove the antenna from the EUT and then connect a low RF cable from the antenna port to the spectrum.
- 2) Set the spectrum analyzer: RBW \geq 1% of the span (set 100kHz). VBW \geq RBW, Span = 3MHz. Sweep = auto; Detector Function = Peak. Trace = Maxhold.
- 3) Allow the trace to stabilize. Use the marker-delta function to determine the separation between the peaks of the adjacent channels. The limit is specified in one of the subparagraphs of this Section. Submit this plot.

Limit:

0.025MHz or 2/3 of the 20dB bandwidth (whichever is greater)

Test data:

Appendix for SZEM170800874302

6.8 Hopping Channel Number

Test Configuration:

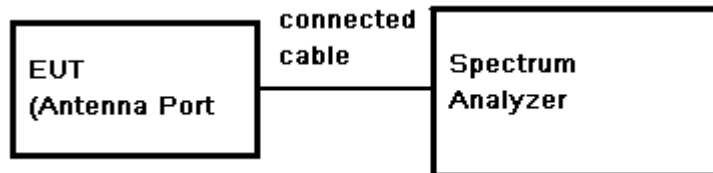

Test Procedure:

- 1) Remove the antenna from the EUT and then connect a low RF cable from the antenna port to the spectrum.
- 2) Set the spectrum analyzer: RBW = 100 kHz. VBW = 300 kHz. Sweep = auto; Detector Function = Peak. Trace = Max hold.
- 3) Allow the trace to stabilize. It may prove necessary to break the span up to sections. in order to clearly show all of the hopping frequencies. The limit is specified in one of the subparagraphs of this Section.
- 4) Set the spectrum analyzer: start frequency = 2400MHz. stop frequency = 2483.5MHz. Submit the test result graph.

Limit: At least 15 channels

Test Data:

Appendix for SZEM170800874302

6.9 Dwell Time

Test Configuration:

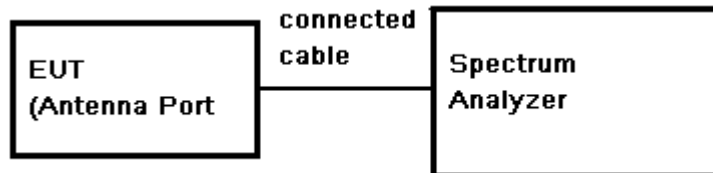

Test Procedure:

- 1) Remove the antenna from the EUT and then connect a low RF cable from the antenna port to the spectrum. Keep EUT in Hopping transmitting with all kind of modulation.
- 2) Set spectrum analyzer span = 0. centered on a hopping channel;
- 3) Use Emission width * No. of Hopping Channels in 31.6s to determine the dwell time.

Limit:

Regulation 15.247(a)(1)(iii) Frequency hopping systems in the 2400-2483.5 MHz band shall use at least 15 channels. The average time of occupancy on any channel shall not be greater than 0.4 seconds within a period of 0.4 seconds multiplied by the number of hopping channels employed. Frequency hopping systems may avoid or suppress transmissions on a particular hopping frequency provided that a minimum of 15 channels are used.

Test Data:

Appendix for SZEM170800874302

6.10 Conducted Spurious Emissions and Band edge

Test Configuration:

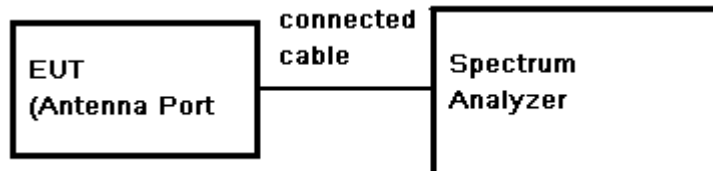

Test Procedure:

- 1) Remove the antenna from the EUT and then connect a low RF cable from the antenna port to the spectrum.
- 2) Set the spectrum analyzer: RBW = 100 KHz. VBW = 300 KHz. Sweep = auto; Detector Function = Peak (Max. hold).
- 3) From fundamental frequency peak point go down 20db and draw a line. This line is limit.

Limit:

(d) In any 100 kHz bandwidth outside the frequency band in which the spread spectrum or digitally modulated intentional radiator is operating, the radio frequency power that is produced by the intentional radiator shall be at least 20 dB below that in the 100 kHz bandwidth within the band that contains the Highest level of the desired power, based on either an RF conducted or a radiated measurement, provided the transmitter demonstrates compliance with the peak conducted power limits.

6.10.1 Conducted Spurious Emissions

Test Data:

Appendix for SZEM170800874302

6.10.2 Conducted Band-edge

Test Data:

Appendix for SZEM170800874302



SGS-CSTC Standards Technical Services Co., Ltd. Shenzhen Branch

No. 1 Workshop, M-10, Middle section, Science & Technology Park,
Shenzhen, Guangdong, China 518057
Telephone: +86 (0) 755 2601 2053
Fax: +86 (0) 755 2671 0594
Email: ee.shenzhen@sgs.com

Report No.: SZEM170800874302
Page: 24 of 38

6.11 Radiated Spurious Emissions and Band-edge

Frequency Range: 9KHz to 25GHz

Test site/setup: Measurement Distance: 3m
Test instrumentation set-up:

Frequency Range	Detector	RBW	VBW
0.009MHz-0.090MHz	Peak	10kHz	30kHz
0.009MHz-0.090MHz	Average	10kHz	30kHz
0.090MHz-0.110MHz	Quasi-peak	10kHz	30kHz
0.110MHz-0.490MHz	Peak	10kHz	30kHz
0.110MHz-0.490MHz	Average	10kHz	30kHz
0.490MHz -30MHz	Quasi-peak	10kHz	30kHz
30MHz-1GHz	Quasi-peak	100kHz	300kHz
Above 1GHz	Peak	RBW=1MHz	VBW≥RBW
	Average		VBW=10Hz

Sweep=Auto

15.209 Limit:

Frequency	Field strength (microvolt/meter)	Limit (dBuV/m)
0.009MHz-0.490MHz	2400/F(KHz)	128.5 ~ 93.8
0.490MHz-1.705MHz	24000/F(KHz)	73.8 ~63.0
1.705MHz-30MHz	30	69.5
30MHz-88MHz	100	40.0
88MHz-216MHz	150	43.5
216MHz-960MHz	200	46.0
960MHz-1GHz	500	54.0
Above 1GHz	500	54.0

Note: 15.35(b), Unless otherwise specified, the limit on peak radio frequency emissions is 20dB above the maximum permitted average emission limit applicable to the equipment under test. This peak limit applies to the total peak emission level radiated by the device.

Test Configuration: Receive antenna scan height 1 m - 4 m. polarization Vertical / Horizontal

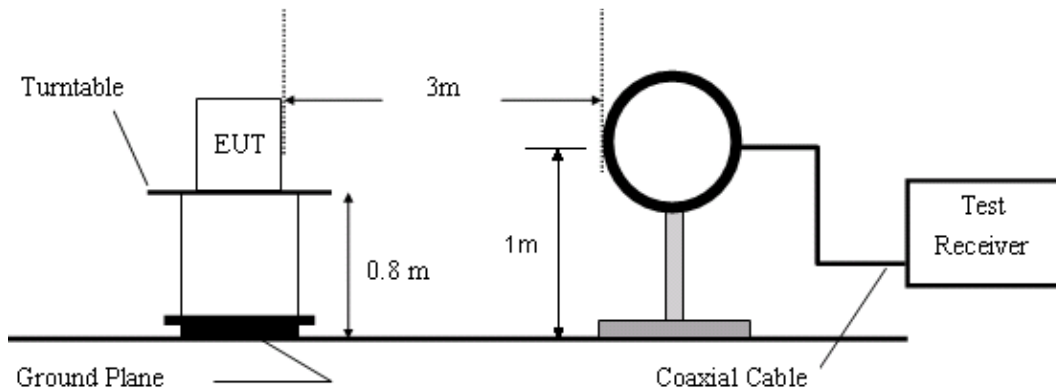

Figure1. Below 30MHz radiated emissions test configuration

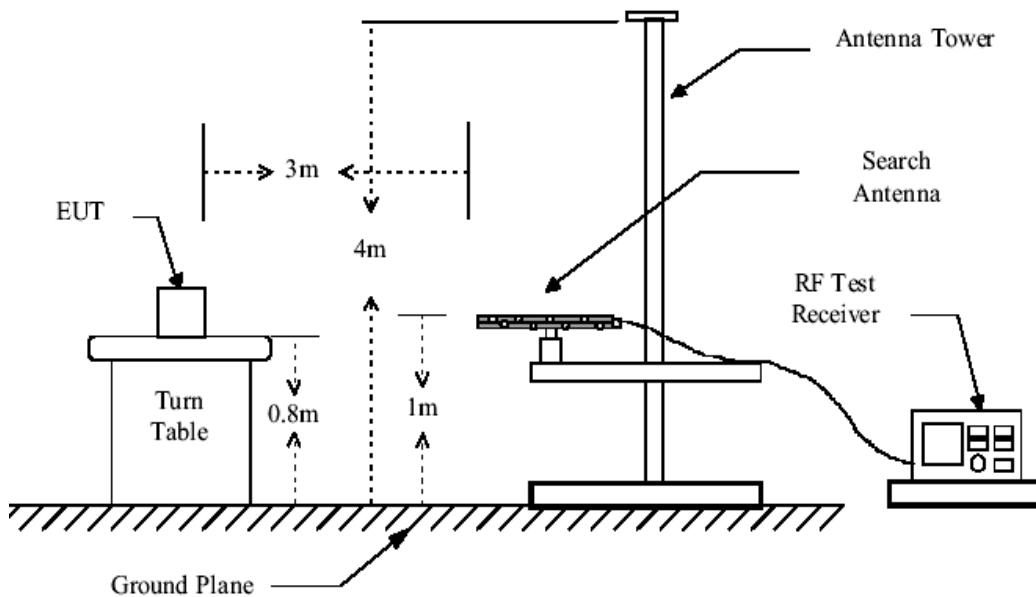

Figure 2. 30MHz to 1GHz radiated emissions test configuration

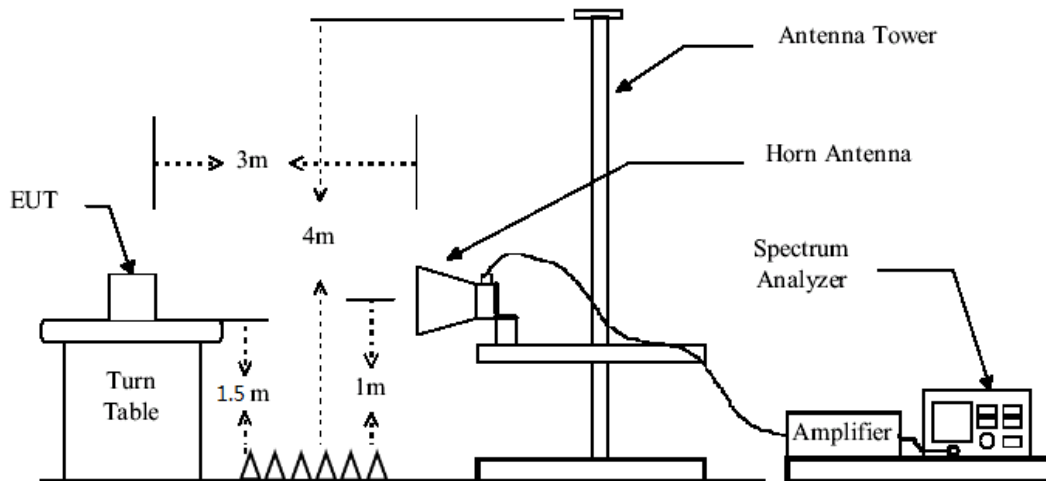

Figure 3. Above 1GHz radiated emissions test configuration

- Test Procedure:**
- 1) The procedure used was ANSI Standard C63.10. The receiver was scanned from 9 KHz to 25GHz. When an emission was found, the table was rotated to produce the maximum signal strength. An initial pre-scan was performed for in peak detection mode using the receiver. The EUT was measured for both the Horizontal and Vertical polarities and performed a pre-test three orthogonal planes. For intentional radiators, measurements of the variation of the input power or the radiated signal level of the fundamental frequency component of the emission, as appropriate, shall be performed with the supply voltage varied between 85% and 115% of the nominal rated supply voltage. The worst case emissions were reported.
 - 2) Low noise amplifier was used below 1GHz, High pass Filter was used above 3GHz. We did not use any amplifier or filter between 1G and 3GHz.
 - 3) Test were performed for their spatial orthogonal(X, Y, Z), the worst test data (X orthogonal) was submitted.
 - a) For this intentional radiator operates below 25 GHz. the spectrum shall be investigated to the tenth harmonic of the highest fundamental frequency. And above the third harmonic of this intentional radiator, the disturbance is very low. So the test result only displays to 5rd harmonic.
 - b) As shown in Section, for frequencies above 1000MHz. the above field strength limits are based on average limits. However, the peak field strength of any emission shall not exceed the maximum permitted average limits specified above by more than 20 dB under any condition of modulation.
 - 4) No spurious emissions were detected within 20dB of limit below 30MHz.

Test Result: Pass



No. 1 Workshop, M-10, Middle section, Science & Technology Park,
 Shenzhen, Guangdong, China 518057
 Telephone: +86 (0) 755 2601 2053
 Fax: +86 (0) 755 2671 0594
 Email: ee.shenzhen@sgs.com

Report No.: SZEM170800874302
 Page: 27 of 38

6.11.1 Radiated Spurious Emissions

30MHz-1GHz:

Polarization: Horizontal

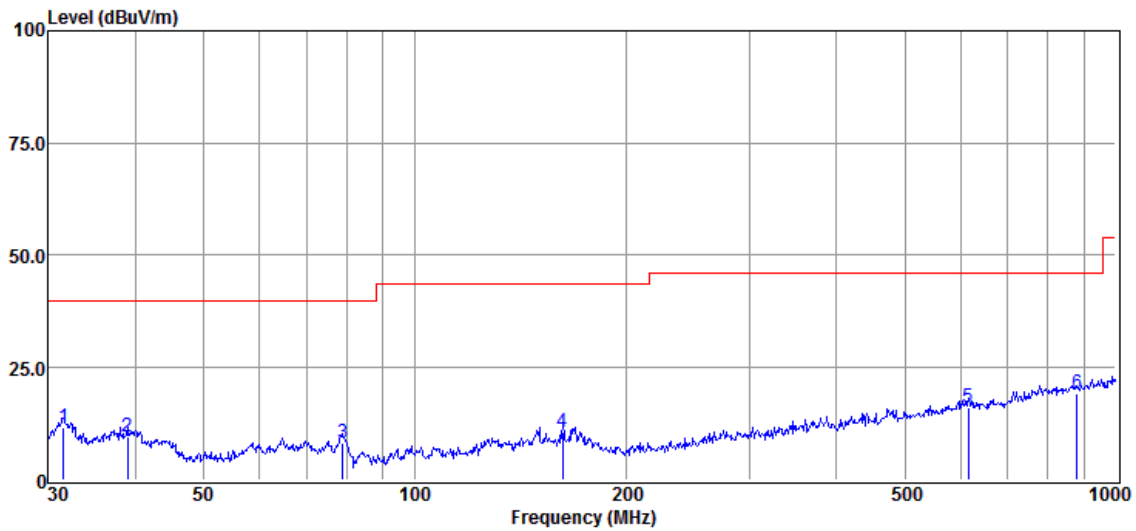

Item	Freq.	Read Level	Antenna Factor	Preamp Factor	Cable Loss	Result Level	Limit Line	Over Limit	Detector
(Mark)	(MHz)	(dBμV)	(dB/m)	(dB)	(dB)	(dBμV/m)	(dBμV/m)	(dB)	
1	31.51	38.75	15.47	42.67	0.19	11.74	40.00	-28.26	QP
2	38.89	35.90	16.20	42.68	0.22	9.64	40.00	-30.36	QP
3	78.97	42.20	8.36	42.69	0.37	8.24	40.00	-31.76	QP
4	162.61	39.82	12.68	42.55	0.64	10.59	43.50	-32.91	QP
5	616.37	37.52	19.55	42.20	1.40	16.27	46.00	-29.73	QP
6	881.41	36.33	22.56	42.12	2.35	19.12	46.00	-26.88	QP



SGS-CSTC Standards Technical Services Co., Ltd. Shenzhen Branch

No. 1 Workshop, M-10, Middle section, Science & Technology Park,
Shenzhen, Guangdong, China 518057
Telephone: +86 (0) 755 2601 2053
Fax: +86 (0) 755 2671 0594
Email: ee.shenzhen@sgs.com

Report No.: SZEM170800874302
Page: 28 of 38

Polarization:Vertical

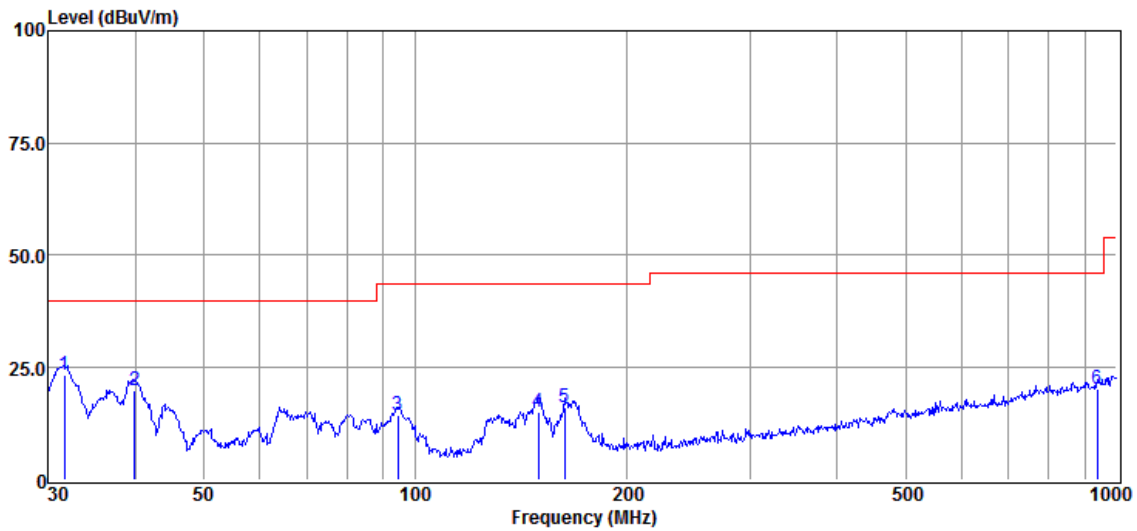

Item	Freq.	Read Level	Antenna Factor	Preamp Factor	Cable Loss	Result Level	Limit Line	Over Limit	Detector
(Mark)	(MHz)	(dBμV)	(dB/m)	(dB)	(dB)	(dBUV/m)	(dBUV/m)	(dB)	
1	31.62	50.47	15.48	42.67	0.19	23.47	40.00	-16.53	QP
2	39.85	46.26	16.29	42.68	0.22	20.09	40.00	-19.91	QP
3	94.43	47.83	8.75	42.70	0.43	14.31	43.50	-29.19	QP
4	150.01	45.24	11.90	42.58	0.62	15.18	43.50	-28.32	QP
5	163.18	45.44	12.60	42.55	0.64	16.13	43.50	-27.37	QP
6	938.83	36.32	23.14	41.80	2.56	20.22	46.00	-25.78	QP

Result Level = Read Level + Antenna Factor + Cable loss - Preamp Factor

Remark:1) Pretest under all modes, choose the worst data 8DPSK for test record of the report



SGS-CSTC Standards Technical Services Co., Ltd. Shenzhen Branch

No. 1 Workshop, M-10, Middle section, Science & Technology Park,
Shenzhen, Guangdong, China 518057
Telephone: +86 (0) 755 2601 2053
Fax: +86 (0) 755 2671 0594
Email: ee.shenzhen@sgs.com

Report No.: SZEM170800874302
Page: 29 of 38

Above 1GHz:

Lowest Channel(2402MHz) Modulation: 8DPSK

Mark	Frequency (MHz)	Reading (dBUV)	Factor (dB)	Emission (dBUV/m)	Limit (dBUV/m)	Over Limit (dB)	Detector	polarization
1	4804	34.79	6.18	40.97	54	-13.03	peak	Horizontal
2	7206	34.19	10.63	44.82	54	-9.18	peak	Horizontal
3	9608	34.81	14.38	49.19	54	-4.81	peak	Horizontal
4	4804	36.11	6.18	42.29	54	-11.71	peak	Vertical
5	7206	36.73	10.63	47.36	54	-6.64	peak	Vertical
6	9608	32.4	14.38	46.78	54	-7.22	peak	Vertical

Middle Channel(2441MHz) Modulation: 8DPSK

Mark	Frequency (MHz)	Reading (dBUV)	Factor (dB)	Emission (dBUV/m)	Limit (dBUV/m)	Over Limit (dB)	Detector	polarization
1	4882	38.13	7	45.13	54	-8.87	peak	Horizontal
2	7323	36.63	11.13	47.76	54	-6.24	peak	Horizontal
3	9764	33.98	14.36	48.34	54	-5.66	peak	Horizontal
4	4882	35.38	7	42.38	54	-11.62	peak	Vertical
5	7323	36.11	11.13	47.24	54	-6.76	peak	Vertical
6	9764	35.56	14.36	49.92	54	-4.08	peak	Vertical

Highest Channel(2480MHz) Modulation: 8DPSK

Mark	Frequency (MHz)	Reading (dBUV)	Factor (dB)	Emission (dBUV/m)	Limit (dBUV/m)	Over Limit (dB)	Detector	polarization
1	4960	34.65	7.49	42.14	54	-11.86	peak	Horizontal
2	7440	38.98	11.65	50.63	54	-3.37	peak	Horizontal
3	9920	33.44	14.4	47.84	54	-6.16	peak	Horizontal
4	4960	36.76	7.49	44.25	54	-9.75	peak	Vertical
5	7440	36.05	11.65	47.7	54	-6.3	peak	Vertical
6	9920	31.75	14.4	46.15	54	-7.85	peak	Vertical

Remark: 1) Emission = Receiver Reading + Factor

2) Factor = Antenna Factor + Cable Loss + Pre-amplifier Factor.

3) If the Peak value below the AV Limit, the AV test doesn't perform for this submission.

4) Remark: Pretest under all modes, choose the worst data 8DPSK for test record of the report

6.11.2 Radiated Band-edge

Lowest Channel (2402MHz)

Modulation: GFSK

MK.	Frequency (MHz)	Reading (dBuV/m)	Corrected factor(dB)	Result (dBuV/m)	Limit (dBuV/m)	Over Limit (dB)	Detector	Polarization
1	2385	44.64	-3.87	40.77	54	-13.23	Peak	Horizontal
2	2390	42.38	-3.89	38.49	54	-15.51	Peak	Horizontal
3	2402.2	98.81	-3.92	94.89	54	40.89	Peak	Horizontal
1	2382	42.23	-3.87	38.36	54	-15.64	Peak	Vertical
2	2390	39.72	-3.89	35.83	54	-18.17	Peak	Vertical
3	2402.2	89.48	-3.92	85.56	54	31.56	Peak	Vertical

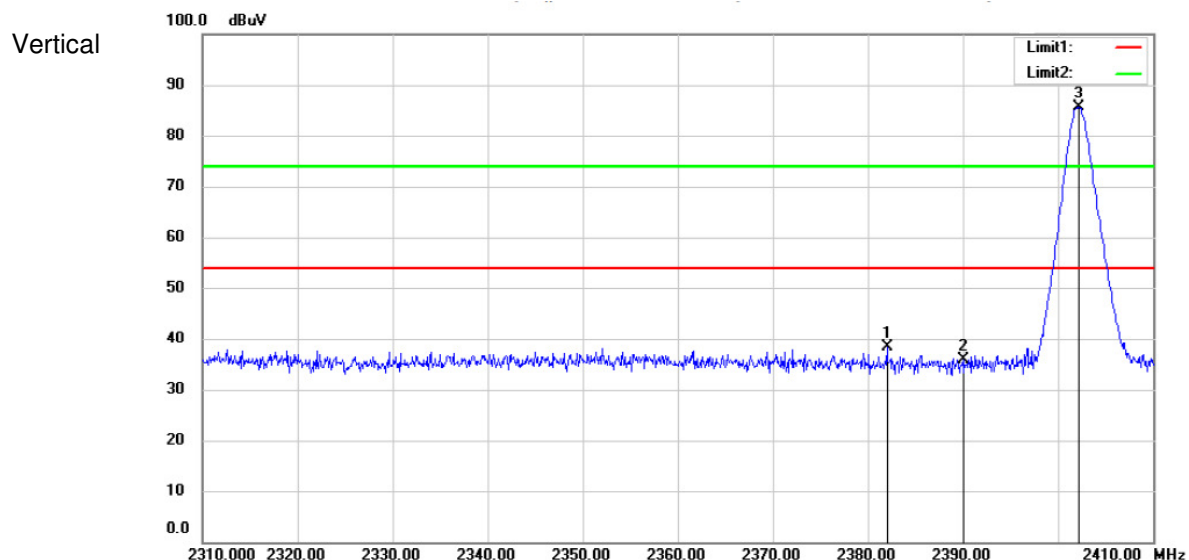
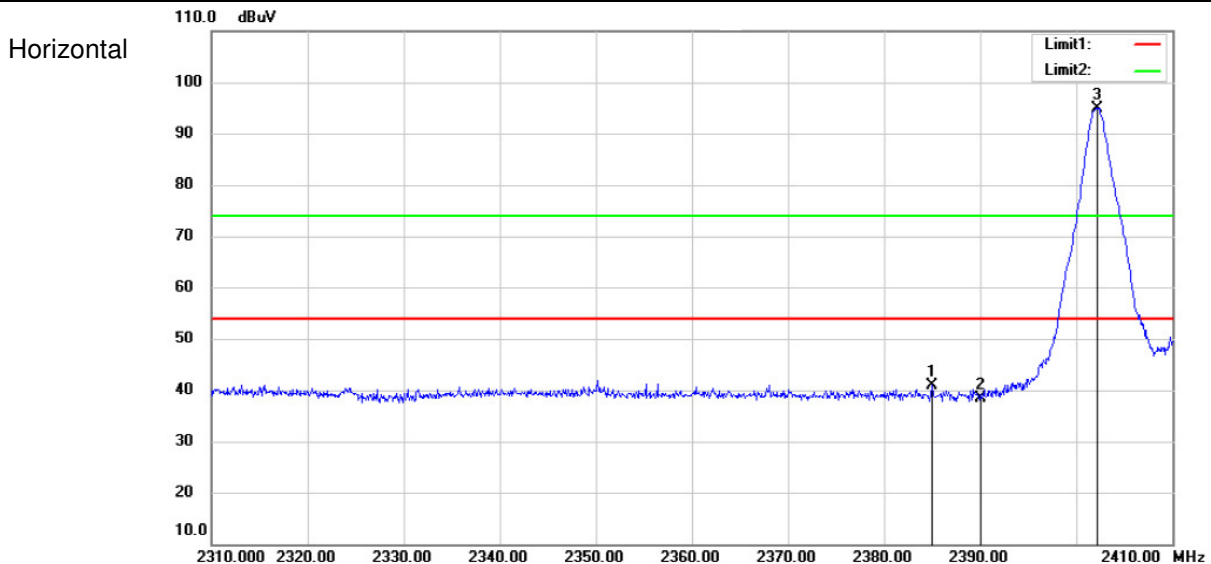

Lowest Channel (2402MHz)

Modulation: $\pi/4$ DQPSK

MK.	Frequency (MHz)	Reading (dBuV/m)	Corrected factor(dB)	Result (dBuV/m)	Limit (dBuV/m)	Over Limit (dB)	Detector	Polarization
1	2372	43.38	-3.84	39.54	54	-14.46	Peak	Horizontal
2	2390	40.97	-3.89	37.08	54	-16.92	Peak	Horizontal
3	2402.1	95.22	-3.92	91.3	54	37.3	Peak	Horizontal
1	2340.1	42.56	-3.74	38.82	54	-15.18	Peak	Vertical
2	2390	39.05	-3.89	35.16	54	-18.84	Peak	Vertical
3	2402.3	85.17	-3.92	81.25	54	27.25	Peak	Vertical

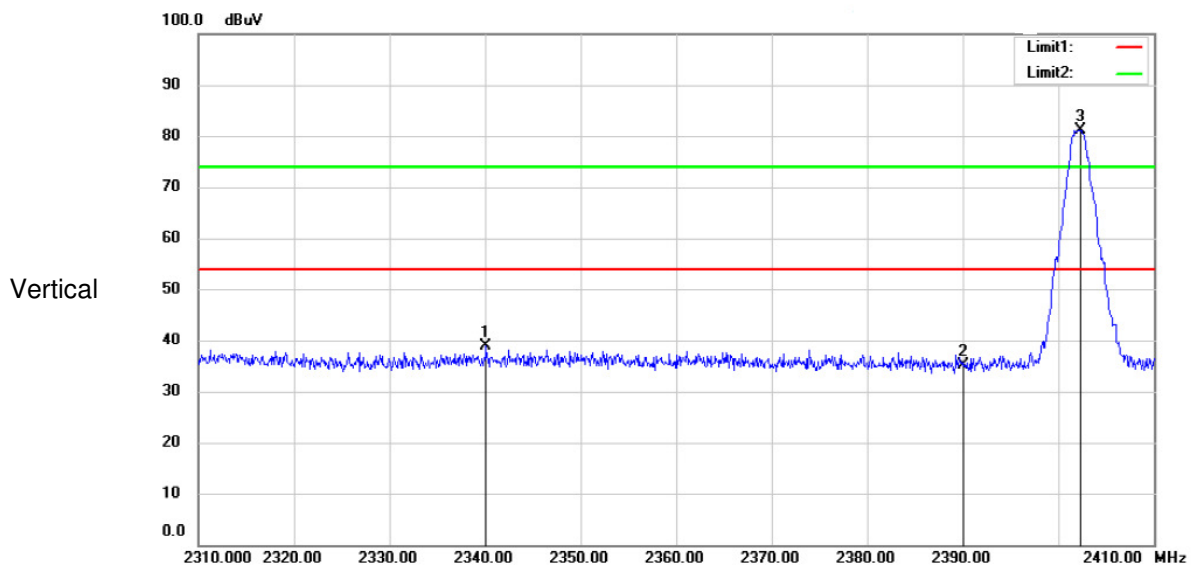
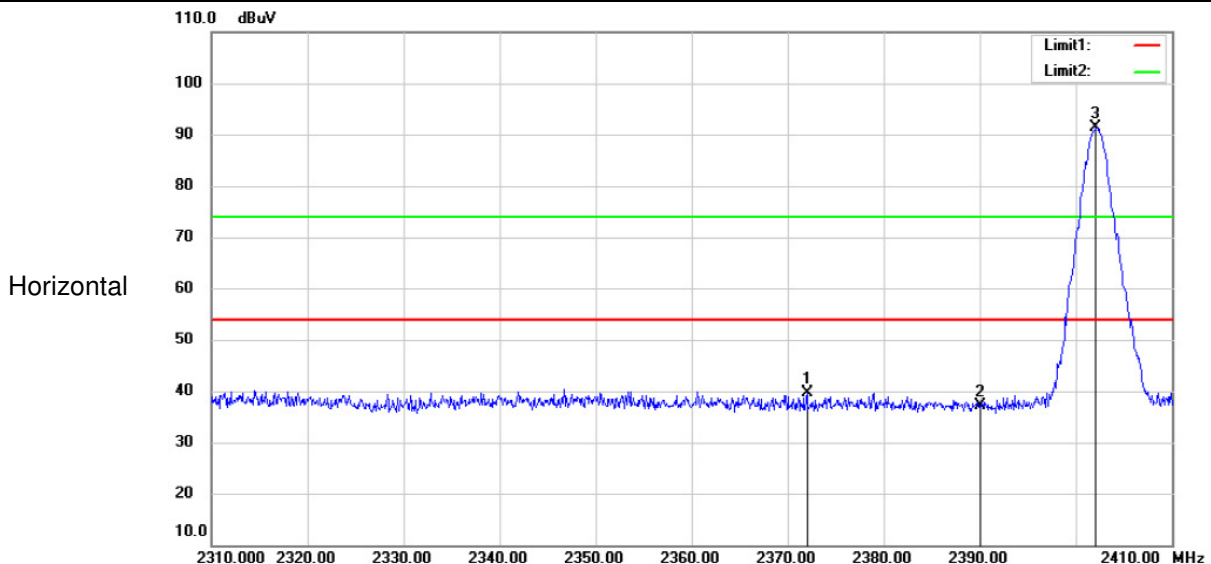



SGS-CSTC Standards Technical Services Co., Ltd. Shenzhen Branch

No. 1 Workshop, M-10, Middle section, Science & Technology Park,
Shenzhen, Guangdong, China 518057
Telephone: +86 (0) 755 2601 2053
Fax: +86 (0) 755 2671 0594
Email: ee.shenzhen@sgs.com

Report No.: SZEM170800874302
Page: 32 of 38

Lowest Channel (2402MHz)

Modulation: 8DPSK

MK.	Frequency (MHz)	Reading (dBuV/m)	Corrected factor(dB)	Result (dBuV/m)	Limit (dBuV/m)	Over Limit (dB)	Detector	Polarization
1	2365.5	43.34	-3.81	39.53	54	-14.47	Peak	Horizontal
2	2390	40.36	-3.89	36.47	54	-17.53	Peak	Horizontal
3	2402.1	95.31	-3.92	91.39	54	37.39	Peak	Horizontal
1	2349.1	42.3	-3.76	38.54	54	-15.46	Peak	Vertical
2	2390	37.58	-3.89	33.69	54	-20.31	Peak	Vertical
3	2401.9	84.45	-3.91	80.54	54	26.54	Peak	Vertical

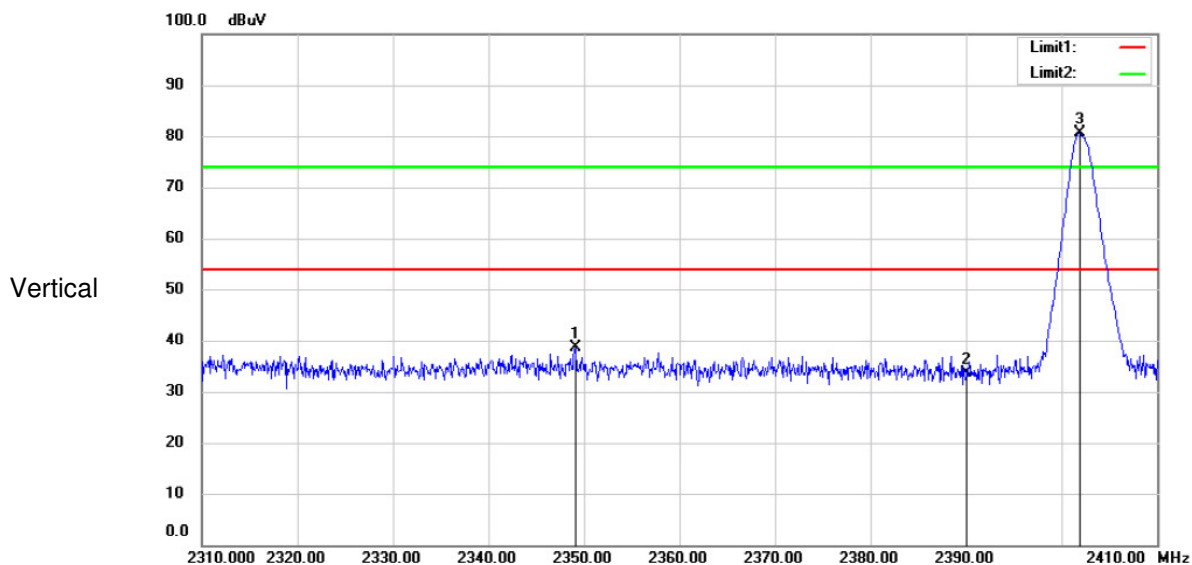
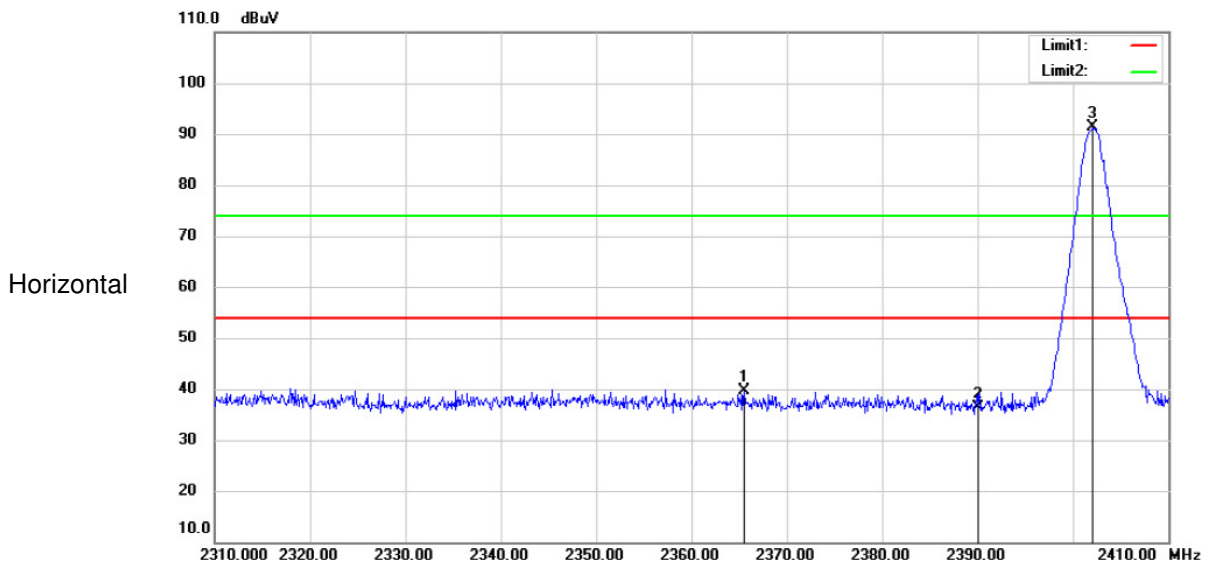



SGS-CSTC Standards Technical Services Co., Ltd. Shenzhen Branch

No. 1 Workshop, M-10, Middle section, Science & Technology Park,
Shenzhen, Guangdong, China 518057
Telephone: +86 (0) 755 2601 2053
Fax: +86 (0) 755 2671 0594
Email: ee.shenzhen@sgs.com

Report No.: SZEM170800874302
Page: 33 of 38

Lowest Channel (2480MHz)

Modulation: GFSK

MK.	Frequency (MHz)	Reading (dBuV/m)	Corrected factor(dB)	Result (dBuV/m)	Limit (dBuV/m)	Over Limit (dB)	Detector	Polarization
1	2479.875	99.06	-4	95.06	74	21.06	Peak	Horizontal
2	2483.5	60.29	-4.01	56.28	74	-17.72	Peak	Horizontal
3	2483.775	58.04	-4.02	54.02	74	-19.98	Peak	Horizontal
1	2479.95	96.43	-4	92.43	54	38.43	Average	Horizontal
2	2483.5	55.42	-4.01	51.41	54	-2.59	Average	Horizontal
3	2483.925	51.92	-4.02	47.9	54	-6.1	Average	Horizontal

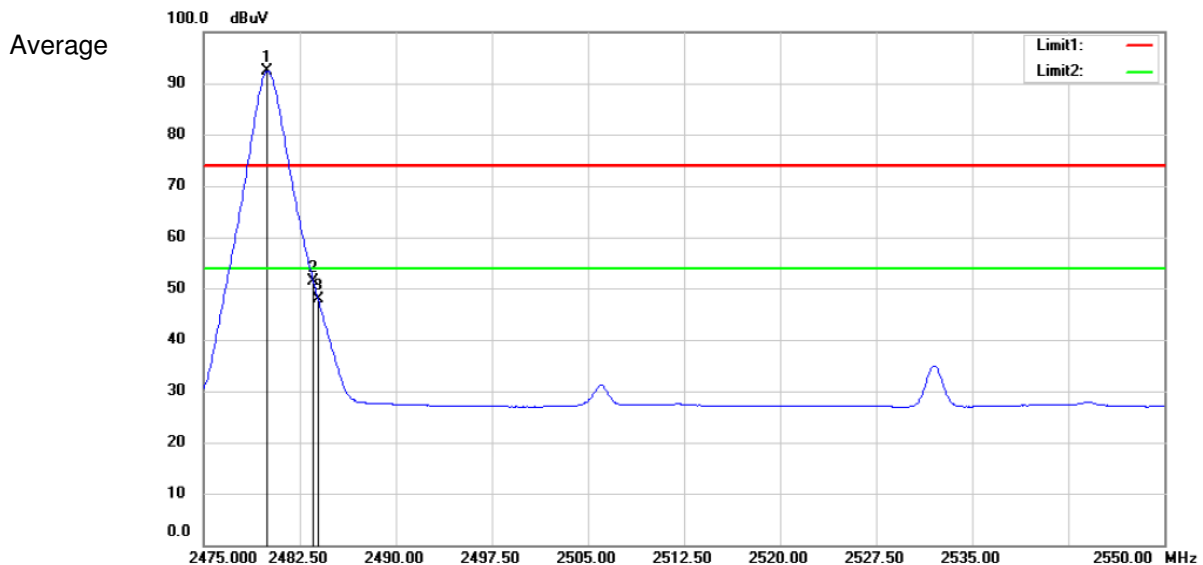
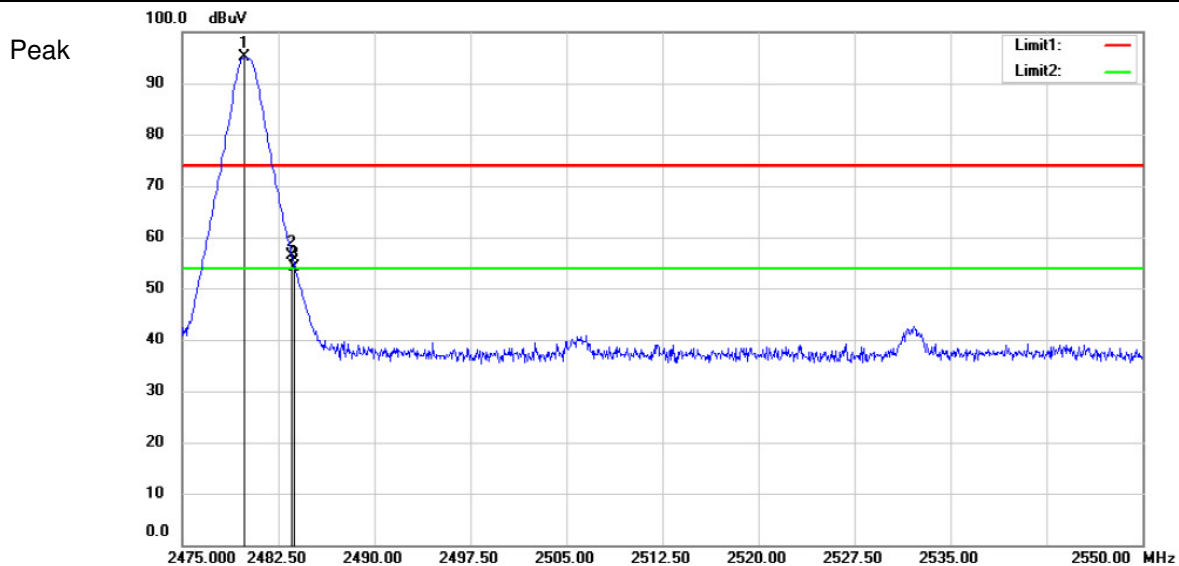



SGS-CSTC Standards Technical Services Co., Ltd. Shenzhen Branch

No. 1 Workshop, M-10, Middle section, Science & Technology Park,
Shenzhen, Guangdong, China 518057
Telephone: +86 (0) 755 2601 2053
Fax: +86 (0) 755 2671 0594
Email: ee.shenzhen@sgs.com

Report No.: SZEM170800874302
Page: 34 of 38

Lowest Channel (2480MHz)

Modulation: GFSK

MK.	Frequency (MHz)	Reading (dBUV/m)	Corrected factor(dB)	Result (dBUV/m)	Limit (dBUV/m)	Over Limit (dB)	Detector	Polarization
1	2479.875	91.68	-4	87.68	54	33.68	Peak	Vertical
2	2483.5	53.16	-4.01	49.15	54	-4.85	Peak	Vertical
3	2484.075	48.46	-4.02	44.44	54	-9.56	Peak	Vertical

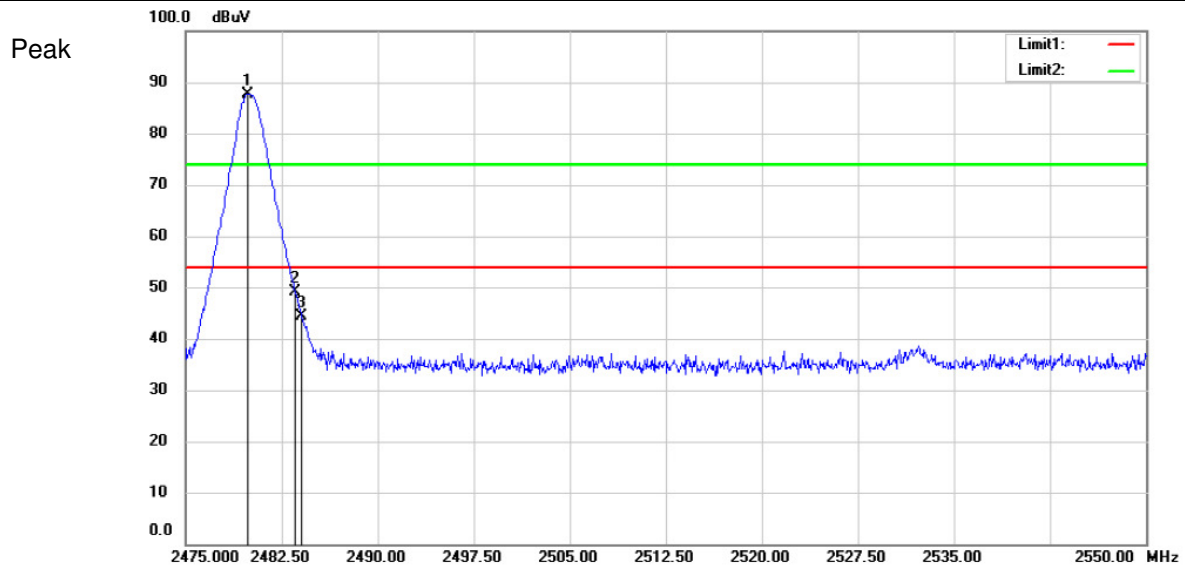



SGS-CSTC Standards Technical Services Co., Ltd. Shenzhen Branch

No. 1 Workshop, M-10, Middle section, Science & Technology Park,
Shenzhen, Guangdong, China 518057
Telephone: +86 (0) 755 2601 2053
Fax: +86 (0) 755 2671 0594
Email: ee.shenzhen@sgs.com

Report No.: SZEM170800874302
Page: 35 of 38

Lowest Channel (2480MHz)

Modulation: $\pi/4$ DQPSK

MK.	Frequency (MHz)	Reading (dBuV/m)	Corrected factor(dB)	Result (dBuV/m)	Limit (dBuV/m)	Over Limit (dB)	Detector	Polarization
1	2479.8	95.27	-4	91.27	54	37.27	Peak	Horizontal
2	2483.5	56.65	-4.01	52.64	54	-1.36	Peak	Horizontal
3	2483.85	53.75	-4.02	49.73	54	-4.27	Peak	Horizontal
1	2480.1	87.65	-4	83.65	54	29.65	Peak	Vertical
2	2483.5	49.66	-4.01	45.65	54	-8.35	Peak	Vertical
3	2483.925	45.66	-4.02	41.64	54	-12.36	Peak	Vertical

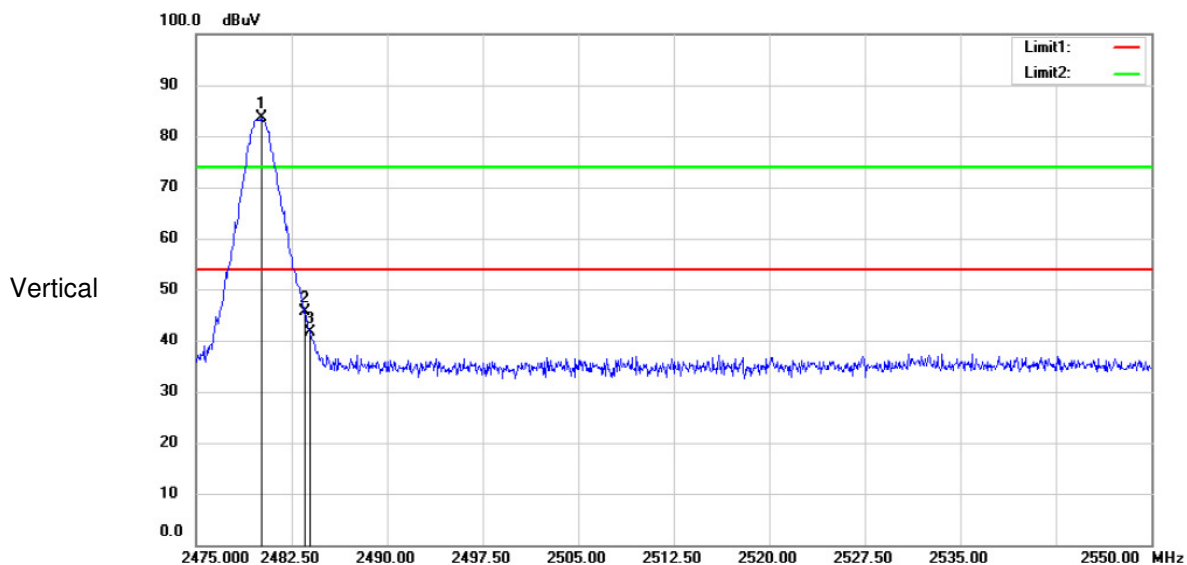
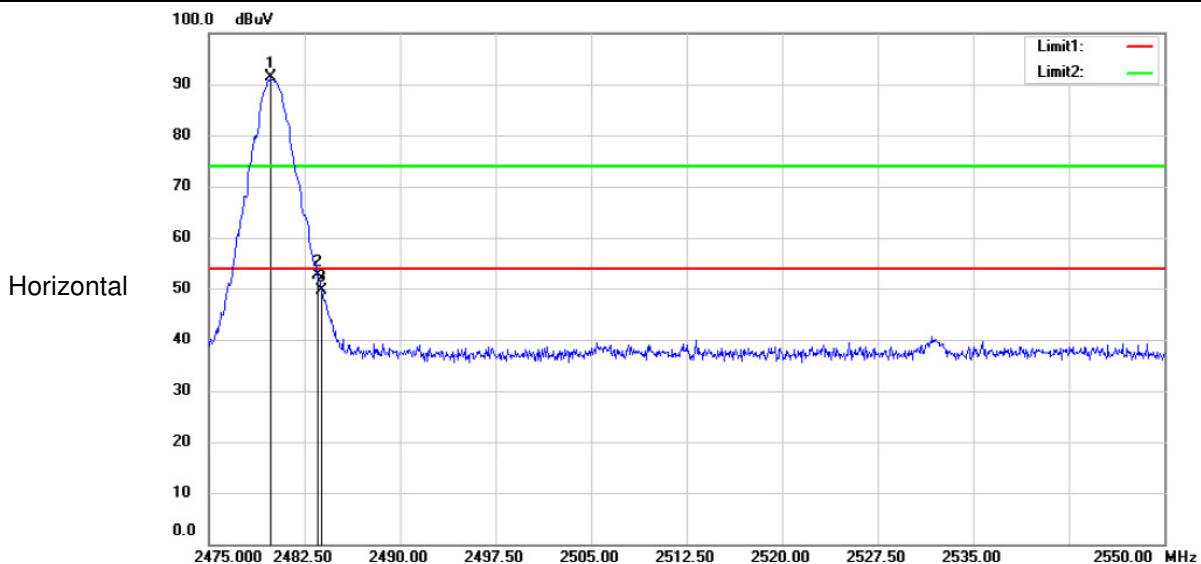



SGS-CSTC Standards Technical Services Co., Ltd. Shenzhen Branch

No. 1 Workshop, M-10, Middle section, Science & Technology Park,
Shenzhen, Guangdong, China 518057
Telephone: +86 (0) 755 2601 2053
Fax: +86 (0) 755 2671 0594
Email: ee.shenzhen@sgs.com

Report No.: SZEM170800874302
Page: 36 of 38

Lowest Channel (2480MHz)

Modulation: 8DPSK

MK.	Frequency (MHz)	Reading (dBuV/m)	Corrected factor(dB)	Result (dBuV/m)	Limit (dBuV/m)	Over Limit (dB)	Detector	Polarization
1	2479.95	95.12	-4	91.12	54	37.12	Peak	Horizontal
2	2483.5	56.56	-4.01	52.55	54	-1.45	Peak	Horizontal
3	2483.85	53.38	-4.02	49.36	54	-4.64	Peak	Horizontal
1	2479.8	87.82	-4	83.82	54	29.82	Peak	Vertical
2	2483.5	50.23	-4.01	46.22	54	-7.78	Peak	Vertical
3	2484.15	44.61	-4.02	40.59	54	-13.41	Peak	Vertical

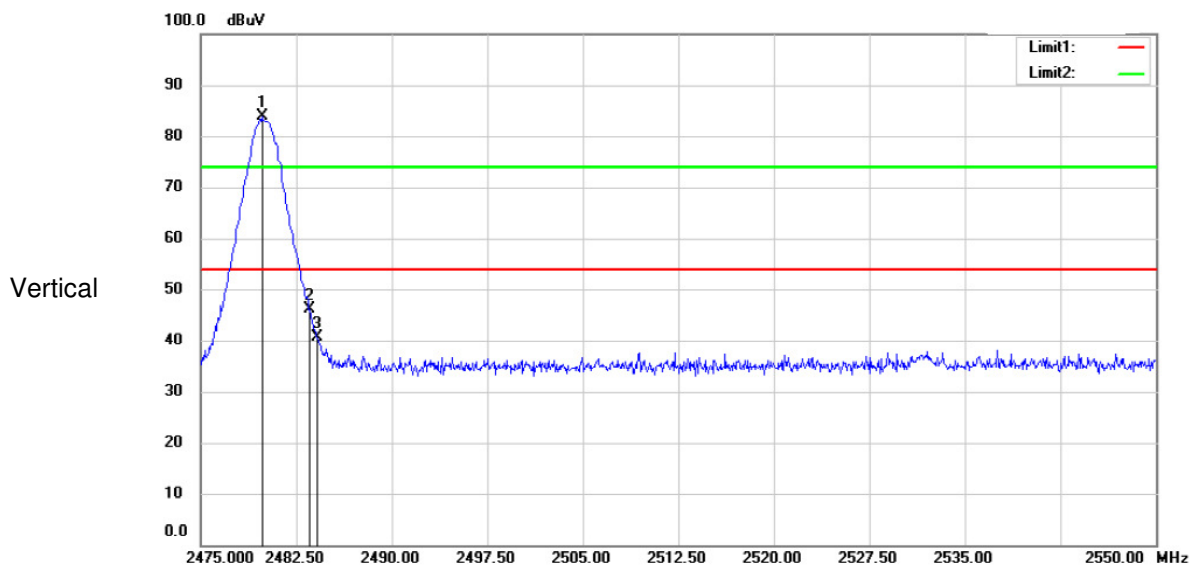
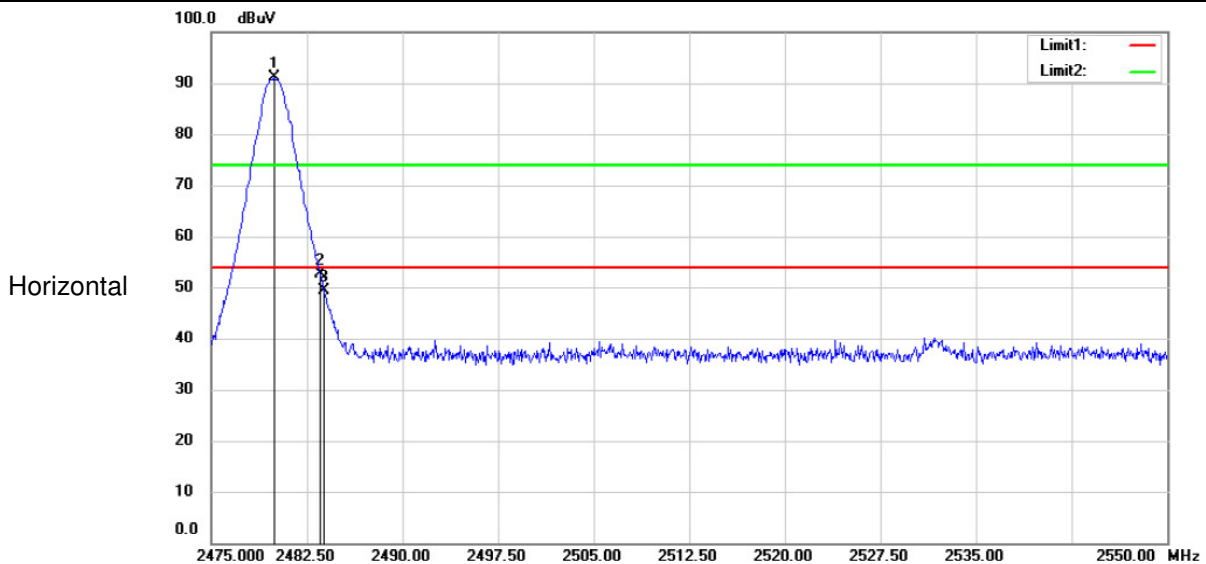



SGS-CSTC Standards Technical Services Co., Ltd.
Shenzhen Branch

No. 1 Workshop, M-10, Middle section, Science & Technology Park,
Shenzhen, Guangdong, China 518057
Telephone: +86 (0) 755 2601 2053
Fax: +86 (0) 755 2671 0594
Email: ee.shenzhen@sgs.com

Report No.: SZEM170800874302
Page: 37 of 38

- Remark: 1). Test Level = Receiver Reading + Antenna Factor + Cable Loss- Preamplifier Factor
2). If the Peak value below the AV Limit, the AV test doesn't perform for this submission.

All frequencies within the "Restricted bands" have been evaluated to compliance. Except as shown in paragraph of this section, only spurious emissions are permitted in any of the frequency bands listed below:

a. FCC Part 15, Subpart C Section 15.205 Restricted bands of operation.

MHz	MHz	MHz	GHz
0.090 - 0.110	16.42 - 16.423	399.9 - 410	4.5 - 5.15
¹ 0.495 - 0.505	16.69475 - 16.69525	608 - 614	5.35 - 5.46
2.1735 - 2.1905	16.80425 - 16.80475	960 - 1240	7.25 - 7.75
4.125 - 4.128	25.5 - 25.67	1300 - 1427	8.025 - 8.5
4.17725 - 4.17775	37.5 - 38.25	1435 - 1626.5	9.0 - 9.2
4.20725 - 4.20775	73 - 74.6	1645.5 - 1646.5	9.3 - 9.5
6.215 - 6.218	74.8 - 75.2	1660 - 1710	10.5 - 12.7
6.26775 - 6.26825	108 - 121.94	1718.8 - 1722.2	13.25 - 13.4
6.31175 - 6.31225	123 - 138	2200 - 2300	14.47 - 14.5
8.291 - 8.294	149.9 - 150.05	2310 - 2390	15.35 - 16.2
8.362 - 8.366	156.52475 - 156.52525	2483.5 - 2500	17.7 - 21.4
8.37625 - 8.38675	156.7 - 156.9	2655 - 2900	22.01 - 23.12
8.41425 - 8.41475	162.0125 - 167.17	3260 - 3267	23.6 - 24.0
12.29 - 12.293	167.72 - 173.2	3332 - 3339	31.2 - 31.8
12.51975 - 12.52025	240 - 285	3345.8 - 3358	36.43 - 36.5
12.57675 - 12.57725	322 - 335.4	3600 - 4400	
13.36 - 13.41			



SGS-CSTC Standards Technical Services Co., Ltd. Shenzhen Branch

No. 1 Workshop, M-10, Middle section, Science & Technology Park,
Shenzhen, Guangdong, China 518057
Telephone: +86 (0) 755 2601 2053
Fax: +86 (0) 755 2671 0594
Email: ee.shenzhen@sgs.com

Report No.: SZEM170800874302
Page: 38 of 38

7 Test Setup Photographs

Refer to the <Test Setup photos-FCC>.

8 EUT Constructional Details

Refer to the <External Photos-FCC> & < Internal Photos-FCC>.

--End of the Report--