

User Manual

WIRELESS IN-EAR EARBUDS

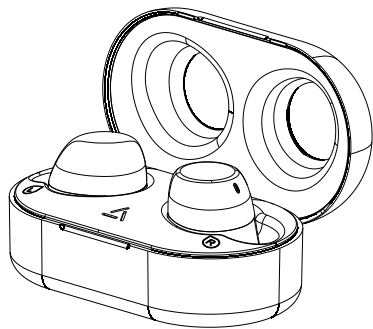

Initial use

- Take out the two earphones, tear off the insulation sticker, and then put the earphones into the charging box again.
- Turn on automatically when taking out the earphones(Usually the left side is the main engine)
- The left side earphone will get into the Bluetooth model. And it will show the green and blue lights flicker alternately(the right side lights out)
- Turn on Bluetooth on your cellphone or other electrical products, find out the "DE 01" , and then click on and link. And it is successful when you hear a voice say " Connected" .

-9-

Function

1、 Turn on/off

Taking out the earphone from the charging box, it will turn on automatically. It charges automatically when put it into the charging box. It will automatically turn off, If the earphone takes out the charging box and can't find the phone after 10 minutes, and then it need to put back into the charging box to wake up.

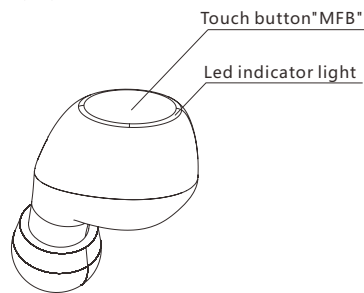

-10-

2、 Touch key function

-
- Touch the earphone and answer directly when the calling income,
 - Touching the earphone means pausing / playing when we listen to music
 - Double touch means a refusal to answer a call
 - When listening to the song, long touch the right earphone to enter the next song, long touch the left earphone to enter the previous song
 - Waking up standby player by touching products
 - Double touching wakes up Siri

-11-

Charge the earphone

Put the earphones in the charging box. The earphone starts charging when the earphone is green. When the earphone is full of electricity, the lights are out.

Battery level

Earphones can let you know the power level. When the battery lasts only 5 minutes, every 100 seconds you will hear the "insufficient power, please charge".

Indicator lamp

Charging	Green lamp
Finish	Lights out
Pairing	Green and blue light flickering
Connected	Lights out

Charge for charging box

Put the charging wire into the charger interface to charge the charging box and the earphone. During charging, the charge box indicator lights up.

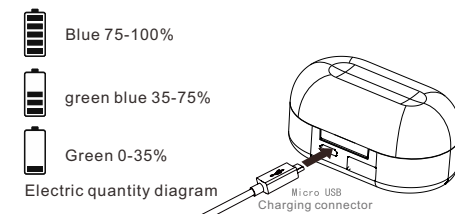

Note: If attempt to remove or replace the battery, it would damage the product and invalidate its warranty

-12-

Mobile phone emergency charging

The charging box of this product has mobile power function and USB standard interface, it can provide about 30% of the power of mobile phone emergency charge.

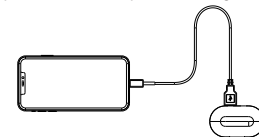

Advanced operation

1.Disconnect the left and right earphone

When we need to use the left and right headphones separately on the two mobile phones. Firstly, disconnect the left and right headphones, put the headphones in the charging box, and touch the headphone 3 times, when the led lamp flicker twice, it indicates that the headphone interconnection has been successfully unconnected. Secondly, take the headphone out the charging box, the left and right headphones will enter the matching mode of "DE 01 R" and "DE 01 L" respectively, so we can pair the left and right headphones separately with two phones.

2. Connect the left and right earphone

Restore the left and right headphones. Firstly, turn on the phone and find Bluetooth, delete "DE 01 R" and "DE 01 L" in my device. Secondly, removing the earphone from the charging box, waiting for 3-5 seconds after the green and blue lights flash, and long touch buttons for 3-5 seconds, after that they will enter the two headphones interconnect state. At this time only blue lights flicker, wait 3-5 seconds after the right headphone lights off, left earphone green and blue led lamp flash, it indicates that interconnection is successful. Finally, turn on the phone Bluetooth, refreshing the device, and find "DE01 L" and click it.

Note: This operation is only for users. And please repeating multiple times if the pairing is unsuccessful.

-13-

Warning

The correct way of wearing:

Place earphones in the ear and gently rotate until 45 degrees above (as shown below), at the same time the earphone without falling. The wrong way to wear will affect the earphone signal and microphone calls.

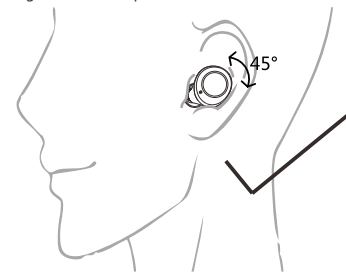

The wrong way of wearing:

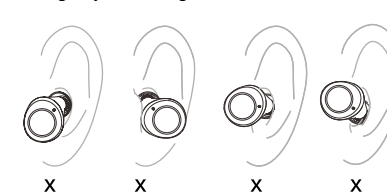

-14-

Detail information

Size: 26mm(L)*20mm(W)*25 mm(H)
Weight: 4.23 g
Charging current: 40 mA
Charging time: about 1 hour
Working voltage: 3.3 V-4.2V
Standby time: around 40 hours
Listening music time: 2-2.5 hours
Talking time: 3 hours
Support for profile: HSP, HFP, A2DP, AVRCP
RF emission frequency: class 2
Transmission category(GHz): 2.402 GHz-2.48GHz
Transmission distance: 10 m
Audio sampling accuracy: 16 bits
Audio sampling rate: up to 96 kHz
Audio coding format: CVSD, mSBC, SBC, AAC
Noise-signal ratio: > 95 dB
Working temperature: -15°C~60°C
Working wet: 10%~85%(Non-freezing state)

Headphone horn information:

Specification: Φ6 mm
Impedance: 16 Ω/typ
Frequency(Hz): 20 Hz~20 KHz
Sensitivity: 93±3 dB
Input power: 2mW~5mW

Microphone information

M/C style: silicon microphone
M/C sensitivity: -42±3dB
SPL: 130 dB

-15-

Charging box information

Size: 70*40*34 mm weight:47 g
Charge port: Micro USB
Charge times(with full current state): 5 times
Charging time: about 2 h

Security instructions

To avoid hearing loss, please keeping the volume at an appropriate level.
Avoid listening to music at high volume for long time, which can cause permanent hearing damage or hearing loss.
Please do not use the earphone when you are driving, riding and crossing the street.
Note: If you are using headphones to watch a video, the audio settings may be out of sync

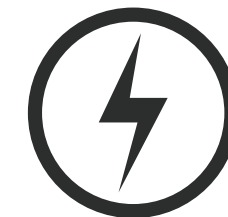

Please pull the charging wire out after finish charging, which is in order to avoid the products in the long charging state.
5V/1A or 5V/1.5A is the best choice for the charger. But if the output voltage and current of the charger exceed the specified value, the product will be seriously damaged and the warranty period will be invalid.

-16-

FCC Statement

Operation is subject to the following three conditions:

- This device may not cause harmful interference, and
- This device must accept any interference received, including interference that may cause undesired operation.
- This device has been evaluated to meet general RF exposure requirement. The device can be used in portable exposure condition without restriction.

NOTE:

This equipment has been tested and found to comply with the limits for a Class B digital device, pursuant to part 15 of the FCC Rules. These limits are designed to provide reasonable protection against harmful interference in a residential installation. This equipment generates, uses and can radiate radio frequency energy and, if not installed and used in accordance with the instructions, may cause harmful interference to radio communications. However, there is no guarantee that interference will not occur in a particular installation. If this equipment does cause harmful interference to radio or television reception, which can be determined by turning the equipment off and on, the user is encouraged to try to correct the interference by one or more of the following measures:

-17-

- Reorient or relocate the receiving antenna.
- Increase the separation between the equipment and receiver.
- Connect the equipment into an outlet on a circuit different from that to which the receiver is connected.
- Consult the dealer or an experienced radio/TV technician for help.

Any Changes or modifications not expressly approved by the party responsible for compliance could void the user's authority to operate the equipment.

-18-